



SOCIETY OF AUTOMOTIVE ENGINEERS, INC.
Two Pennsylvania Plaza, New York, N. Y. 10001

Space Shuttle Structural Design Concepts and Fabrication Problems

DTIC QUALITY INSPECTED 2

R. A. Lusk
Space Division
North American Rockwell

19960314 009

SOCIETY OF AUTOMOTIVE ENGINEERS

National Aeronautic and Space Engineering
and Manufacturing Meeting
Los Angeles, Calif.
October 5-9, 1970

700768

DISTRIBUTION STATEMENT A

Approved for public release;
Distribution Unlimited

PLAS 1614810

Space Shuttle Structural Design Concepts and Fabrication Problems

R. A. Lusk
Space Division
North American Rockwell

ABSTRACT

One of the next steps in man's exploration of space is the development of a reusable space system capable of transporting men and equipment to near-earth orbits and returning them safely to earth. NASA's Space Shuttle Program is designed to achieve this goal in the 1970's with a reusable space orbiter and a reusable booster. This paper identifies the structural problems inherent in these craft and discusses the structural details of the orbiter design being studied by North American Rockwell's Space Division. In this Phase B study, which is being conducted under contract for NASA's Manned Spacecraft Center, cost is accorded primary consideration in all technical tradeoffs.

INTRODUCTION

One small step for a man, one giant leap for mankind. These historic words, spoken by Neil Armstrong as he stepped upon the lunar surface on July 20, 1969, aptly describe the advancement made in space flight during the last decade. However, if space operations are to become practical, the cost of putting a payload in orbit must be drastically reduced. A basic goal of NASA's Space Shuttle Program is to reduce that cost and to produce an operational space transportation system in this decade.

The concept of a low-cost, reusable launch vehicle/spacecraft poses unique challenges to the structural designer. The extreme limits of the environments in which the shuttle must operate

will tax his ingenuity as well as force the use of new and exotic materials. However, while these technological advances are formidable, they are not insurmountable. The primary aim of this paper is to discuss some of the problems being met during the program-definition phase of space shuttle.

DESIGN REQUIREMENTS

The basic requirement of the space shuttle study is to maximize the payload that can be placed in a 100-nautical-mile orbit by a vehicle with a gross lift-off weight not exceeding 3.5 million pounds. In addition, the cargo bay must be capable of accommodating a cargo container 15 feet in diameter and 60 feet long, the booster and orbiter must be reusable, and the system must have a life of 100 missions. The Space Division's orbiter, which is designed to meet these criteria, is shown in Fig. 1; Fig. 2 illustrates an alternate configuration. The latter, although it maximizes cross range, develops a much larger total heat load during entry and undergoes higher entry temperatures (Fig. 3).

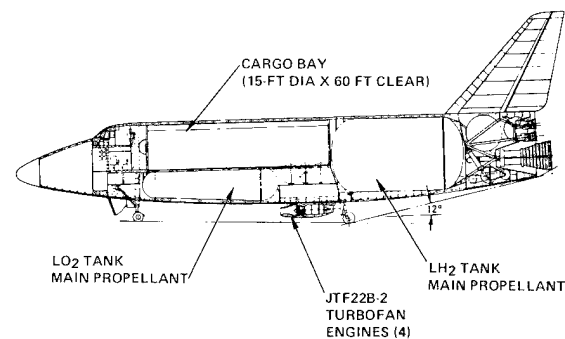

Fig. 1. Low cross-range orbiter configuration

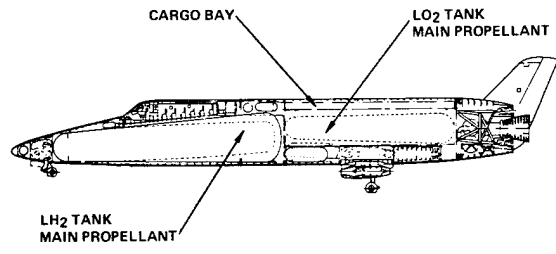

Fig. 2. High cross-range orbiter configuration

Sensitivity of structural weight to system performance and payload weight (Reference 1) is not treated here. Suffice it to say that an underestimation of structural weight on the order of 10 percent would remove all payload capability. Obviously, this provides a strong impetus to design the most efficient structural arrangement. However, since cost is also a prime mover, this efficient structure must also be cost-effective.

Another factor related to structural efficiency is volumetric efficiency. The volumetric efficiency of

the booster is inherently higher than that of the orbiter because the orbiter must accommodate the cargo bay. This 10,000-cubic-foot volume (which is equivalent to a medium-sized home) does not lend itself to efficient packaging. Moreover, the aerodynamic-shape requirements of the orbiter—especially the maximum cross-range configuration—are more stringent than those of the booster. These two factors tend to result in less efficient utilization of the available volume in the orbiter—which is the critical vehicle.

MATERIALS APPLICABILITY

Fig. 3 shows the temperatures that the high cross-range orbiter will experience. These temperatures, especially the higher ones, dictate the materials which may be used in the structure and heat shield. These materials and the temperatures at which they can be used are shown in Table 1.

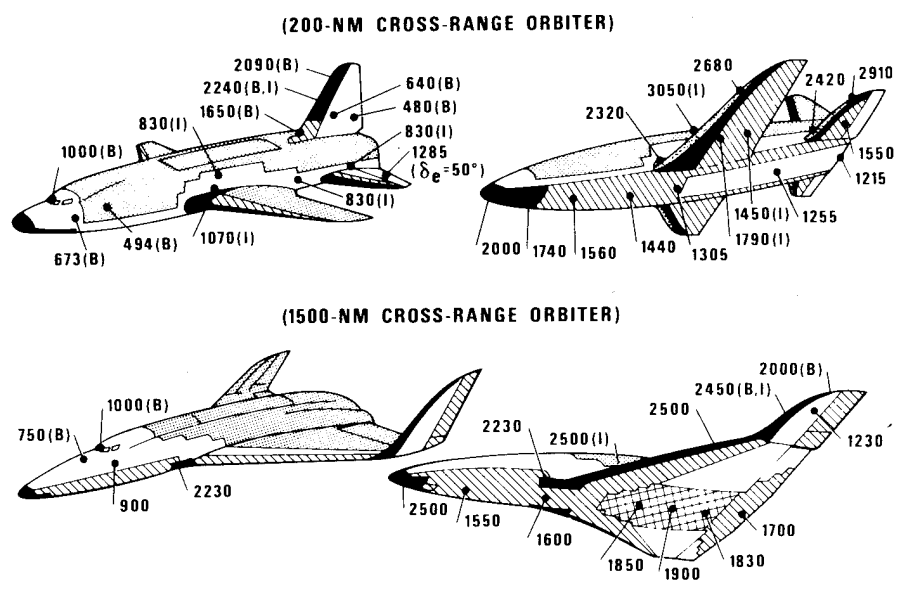

	CODE	TEMP (F)	BASLINE HS MTL	PRIMARY SELECTION CRITERIA
(B) MAXIMUM TEMPERATURE DURING BOOST	[Dotted Box]	> 2500	REINFORCED PYROLIZED PLASTICS	• HIGH-TEMPERATURE PROPERTIES • RESERVE MARGIN
	[Solid Black Box]	2000-2500	COLUMBIUM (129Y) SILICIDE-COATED	• HIGH-TEMPERATURE PROPERTIES • AVAILABILITY
(I) INTERFERENCE (SHOCK IMPINGEMENT)	[Cross-hatched Box]	1800-2000	TD NiCr	• NO OXIDATION COATING REQUIRED
	[Diagonal-hatched Box]	1350-1800	HAYNES 188	• HIGH-TEMPERATURE PROPERTIES • OXIDATION RESISTANCE • AVAILABILITY
OTHER TEMPERATURES ARE FOR ENTRY	[White Box]	600-1350	INCOWEL 718	• HIGH STRENGTH TO 1350 F • FABRICABILITY
	[Light Gray Box]	< 650	TITANIUM 6Al-4V	• HIGH STRENGTH/DENSITY • FABRICABILITY • COST

Fig. 3. Maximum temperature and materials distribution

Table 1. Space Shuttle Materials

MATERIAL	MAX USABLE TEMP (F)	DENSITY (LB/CU IN.)	MATERIAL RELIABILITY	STATE OF MATERIAL DEVELOPMENT	ESTIMATED RAW MATERIAL COST (\$/LB)
TANTALUM	2700	0.604	(COATED) FAIR	LIMITED PROD.	80 TO 100
COLUMBIUM (752 AND 129Y)	2500	0.326 TO 0.343	(COATED) FAIR	LIMITED PROD.	80 TO 125
TD NiCr	2000	0.31	NEEDS EVAL	UNDER DEVEL	80 TO 125
HAYNES 188	1800	0.333	GOOD	LIMITED PROD.	10 TO 20
RENE 41	1650	0.298	GOOD	PRODUCTION	7 TO 10
INCONEL 718	1350	0.297	EXCELLENT	PRODUCTION	4 TO 7
Ti 6Al-4V	1000	0.160	EXCELLENT	PRODUCTION	4 TO 16
ALUMINUM	350	0.102 TO 0.103	EXCELLENT	PRODUCTION	0.60 TO 0.80

Since cost is a major factor, the approximate cost of these materials is also noted. A comparison of the values in this table with temperature plots shows that the shuttle will require the extensive use of superalloys and a significant amount of refractory alloys.

Factors which must be considered include not only the expected specific strength at temperature but also the strength after repeated exposures to high temperatures. Data for materials under consideration are severely lacking. Fortunately, at the time of maximum temperature, the loads are relatively small. Fig. 4 shows the time correlation of temperature and running load in pounds per inch for a point on the orbiter fuselage. As can be seen, the surface temperature will have dropped considerably by the time the orbiter undergoes the maneuver loads.

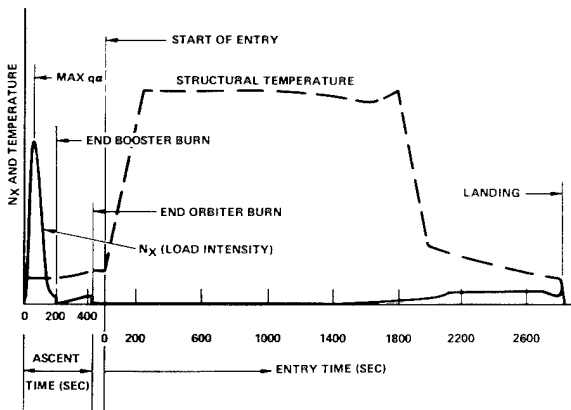

Fig. 4. Load intensity and temperature versus time for hot structure

Most of the materials in Table 1 are in the development stage, and the fabrication techniques and processes are being developed by industry. Engineering and shop personnel have little experience in working with these materials, and they must acquire it in the next few years.

TPS HEAT SHIELD CONCEPTS

The most important structural challenge to be met is the thermal protection system (TPS), or heat shield. This system not only must be able to withstand extreme variations of temperature in protecting orbiter components but must be lightweight and relatively inexpensive. Weight of the TPS is estimated to range between 17 and 23 percent of the structural weight, depending on the concept. These concepts are classified as follows: metallic radiative, reusable external insulation (REI), hot structure, ablative, and cooled (either active or passive). Each has advantages and disadvantages.

The metallic radiative TPS is illustrated in Fig. 5. A Space Division test specimen in which this concept is used is shown in Fig. 6. It features a stiffened sheet panel attached to the basic structure by standoffs that provide thermal and strain isolation. Size of the panel is based on the amount of strain to be accounted for—the larger the panel,

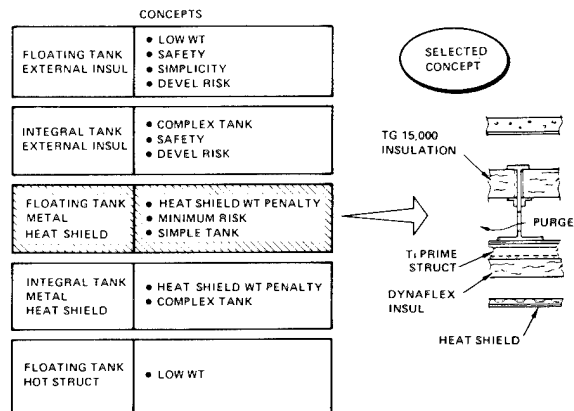

Fig. 5. Orbiter structure/TPS concepts

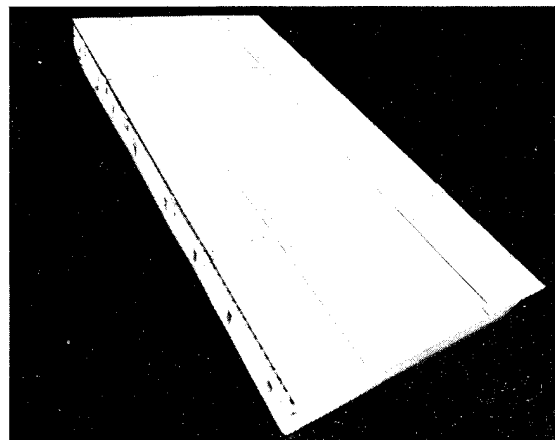

Fig. 6. TPS test specimen

the greater the allowance that must be made for thermal expansion. Designs vary from small panels (1½ by 3 feet) locally supported to full-length shells attached to the basic fuselage by linkages that allow the shell to expand and contract freely.

This type of TPS is simple, and materials are available from which to make it— especially for temperatures below 1800 F. For temperatures above that value, the materials become somewhat more difficult to work with and have some drawbacks; for example, columbium alloys must be coated. The greatest shortcoming is one that is common to all concepts: weight. Although no concept offers as light a TPS as desired, the metallic system tends to be heavier than the others. It does, however, fulfill the reusability requirement.

Reusable external insulation is the most attractive to the structural designer because it isolates the structure from its environmental extremes. Fig. 7 shows how REI can be used. This design features a substrate of fiberglass honeycomb, which provides the requisite strength and on which the REI is mounted. The REI also could be applied directly to the structure in areas where strain compatibility is not a problem. The major drawback of this concept is the inherent lack of strength and ruggedness of lightweight insulators. They also tend to absorb moisture, which suggests the need for the development of a sealer that could protect the outer surface and act as a moisture barrier. This type of insulation is discussed in Reference 2.

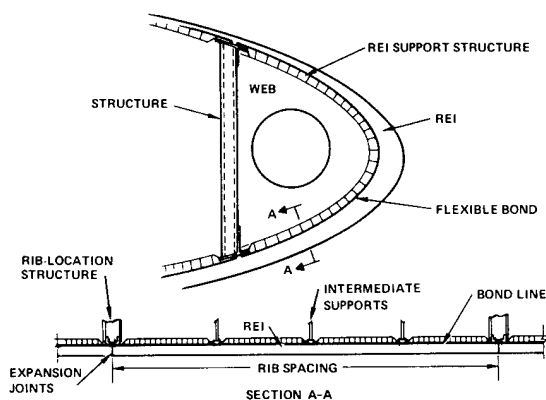

Fig. 7. Typical REI configuration

In terms of manufacturing simplicity, the hot structure is the most attractive concept. Fabrication techniques are more or less conventional. However, the testing and analysis required to verify

the structure are substantially increased. While a hot test of a shuttle structure may not constitute an advancement in state-of-the-art testing, it would certainly require an advancement in the state of facilities. Even the testing of structural components will strain existing facilities. This concept is most attractive for the low cross-range configuration, where peak temperatures are about 1800 F.

There are hot spots on each configuration for which completely reusable heat shields may not be practical. In areas of extremely high heating, ablators could be used, and materials and techniques developed during the last decade could be modified for the shuttle. The major design problem is to develop a practical quick-change technique, so that the ablator may be quickly and easily replaced. If these areas of high heating can be kept reasonably small, ablator panels may be the most practical and economical solution.

The fifth concept involves an active-cooling TPS, which may be required in areas of extremely high heat—such as leading edges. Although being considered, this approach is not as promising as the completely passive system.

DESIGN FEATURES

The space shuttle's design and fabrication problems can best be illustrated by a discussion of design detail. Following are brief descriptions of the fuselage and wing structure.

FUSELAGE — The fuselage structure now envisioned is conventional sheet-stringer frame, with a choice of materials. Comparisons between aluminum at a maximum temperature of 350 F and titanium at a maximum temperature of 600 F are being made with a TPS which reduces the structural temperature to those limits. Although the specific strength of titanium 6Al-4V is higher than that of aluminum, the compressive capability of aluminum construction is more competitive at load intensities (N_x) below 600 pounds per inch (Fig. 8). If it is possible to obtain a reasonable weight comparison, it is obviously more desirable to use aluminum because of its significantly lower fabrication costs.

Other alternatives are being considered for the orbiter fuselage structure. Hot structure, with ring-stiffened shells made of Rene' 41 or of Inconel 718 Stresskin, is of particular interest for the short cross-range orbiter because of its more

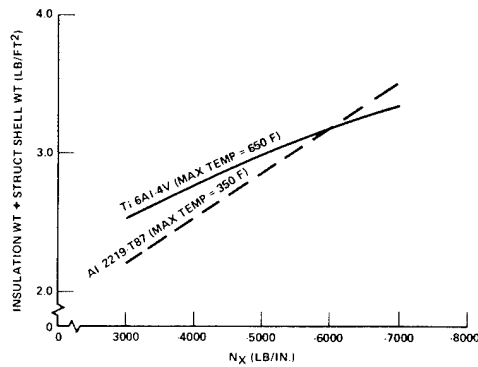

Fig. 8. Titanium-aluminum weight comparison

benign environment. Even in this reduced environment, however, creep strength is extremely critical.

The use of propellant tanks as basic structure is also being considered. Introduction of the large concentrated loads and the transition structure are the primary problem areas for the designer of the load-bearing tanks. This concept is the baseline for the booster, for which it is much more attractive because of the absence of a cargo bay.

The main propellant tank constitutes a significant portion of the structural weight. This tank is basic structure for the booster; it is only a pressure vessel in the orbiter. Load-bearing LH₂ tanks are now under study for the orbiter. Aluminum 2219 alloy was chosen for these tanks because of its compatibility with cryogenics, acceptable strength, good weldability, and fracture toughness.

Since the fuselage is essentially circular, the tank configurations for the straight-wing orbiter are conventional. The LH₂ tank on the delta-wing orbiter is a double-bubble construction, which improves the volumetric efficiency. This tank will require more elaborate tooling and fabrication techniques as well as more design and analysis. The tanks are comparable in size to those of the Saturn V launch vehicle and do not require any technological advances.

The major design problem is the installation and support of the tanks to minimize induced loads due to body bending and to avoid introduction of large concentrated loads. Another design factor to be considered is the amount and type of inspection required to maintain flight certification during the life of the vehicle. The type of cryogenic insulation and the method of installing it is another hurdle to be cleared.

Ideal places to use composites are the cargo bay doors. Stiffness requirements may be the prime

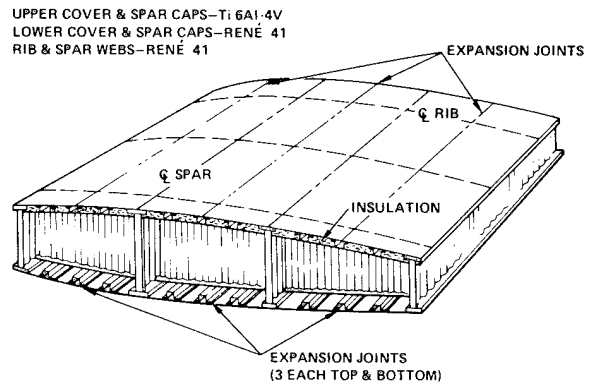

Fig. 9. Typical hot structure wing section

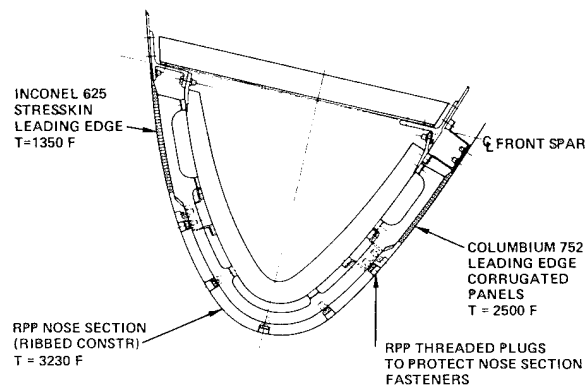

Fig. 10. Typical wing leading edge

consideration, because they will not be subjected to body bending loads; they will be subjected to a differential pressure during boost and ground handling. The engine thrust structure is another area where composites could be used to advantage. Both orbiter and booster tend to be tail heavy, and a reduction in structural weight with no corresponding reduction in stiffness is highly desirable. This could be accomplished with composites.

It should be noted that, in the search for the optimum structure, related components, TPS, and tankage cannot be isolated nor ignored. The entire cross section, from plasma to cryogenics, must be evaluated to arrive at a meaningful comparison between structural concepts.

WING — The baseline wing structure of the low cross-range orbiter is a conventional two-spar wing with hat-stiffened skin. It is made of titanium 6Al-4V and has a metallic heat shield on the lower surface. Also being investigated is a hot-structure wing made of Rene'41. Preliminary estimates indicate a tip deflection, due to differential heating, of approximately 8 feet! Since the design does

not include flaps or ailerons, this deflection is not prohibitive; it just increases the dihedral of the wings. A typical cross section of the wing box shows the concept for supplying chordwise thermal strain relief by using the hat stiffeners as *omega* seals (Fig. 9).

Due to shock-interaction effects, the most severe thermal environment is at the leading edge. As a consequence, the current configuration features coated columbium, carbon-carbon, and Rene' 41 on the lower, nose, and upper surfaces, respectively (Fig. 10).

The wing of the high cross-range orbiter incorporates flap across the full span. A large tip deflection, such as that mentioned for the hot structure straight wing, would not be desirable. For this reason, the baseline wing structure is a conventional multispar delta with hat-stiffened skin. A corrugated skin is being investigated for the under surface, where the TPS provides an aerodynamic fairing.

SUMMARY

As its title implies, this paper attempts to identify the problems of particular interest that must be solved during development of the space shuttle. A compendium of this nature tends to have a negative tone, in spite of the author's desire to the contrary.

At this time, the goals of the Space Shuttle Program appear to be achievable. The problems enumerated here will have to be overcome, but they are not insoluble; they only make the job of the structural designer more interesting and more challenging. Cost enhances the challenge, because it is a primary design factor and must be considered along with weight and the induced environment. For the goal of the Shuttle Program is not simply to build a reusable space vehicle, but to produce one that is both reusable and economically practical. Given the appropriate priority and emphasis, it will be done.

REFERENCES

1. M.A. Silveira, *Structure Design and Fabrication—Key to Space Shuttle Performance and Cost Credibility*. Paper presented at SAE National Aeronautic and Space Engineering and Manufacturing Meeting, Los Angeles, California, October 5-9, 1970.
2. P.D. Gorsuch, R. Tanzilli, D.E. Florence, and R. Gluck, *Development of Nonmetallic External Insulation Thermal Protection Systems for Space Shuttle*. Paper presented at SAE National Aeronautic and Space Engineering and Manufacturing Meeting, Los Angeles, California, October 5-9, 1970.