



ARMSTRONG

**USAF DENTAL INSTRUMENT PROCESSING
CENTER DESIGN GUIDANCE**

John H. Hatfield, Lt Col, USAF, DC
James J. Kane, Lt Col, USAF, DC
Richard H. Blankman

USAF DENTAL INVESTIGATION SERVICE
AEROSPACE MEDICINE DIRECTORATE
2509 Kennedy Circle
Brooks Air Force Base, TX 78235-5117

January 1996

Final Technical Report for Period January 1995 – December 1995

Approved for public release; distribution is unlimited.

LABORATORY

19960311 201



DTIC QUALITY INSPECTED 1

**AIR FORCE MATERIEL COMMAND
BROOKS AIR FORCE BASE, TEXAS**

NOTICES

When Government drawings, specifications, or other data are used for any purpose other than in connection with a definitely Government-related procurement, the United States Government incurs no responsibility or any obligation whatsoever. The fact that the Government may have formulated or in any way supplied the said drawings, specifications, or other data, is not to be regarded by implication, or otherwise in any manner construed, as licensing the holder, or any other person or corporation; or as conveying any rights or permission to manufacture, use, or sell any patented invention that may in any way be related thereto.

The Office of Public Affairs has reviewed this technical report, and it is releasable to the National Technical Information Service, where it will be available to the general public, including foreign nationals.

This technical report has been reviewed and is approved for publication.



RICHARD H. BLANKMAN
Project Architect/Engineer

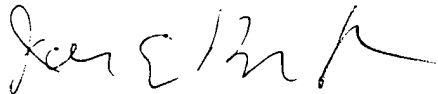

JOE EDWARD BURTON, Colonel, USAF, MC, CFS
Chief, Clinical Sciences Division

REPORT DOCUMENTATION PAGEForm Approved
OMB No. 0704-0188

Public reporting burden for this collection of information is estimated to average 1 hour per response, including the time for reviewing instructions, searching existing data sources, gathering and maintaining the data needed, and completing and reviewing the collection of information. Send comments regarding this burden estimate or any other aspect of this collection of information, including suggestions for reducing this burden, to Washington Headquarters Services, Directorate for Information Operations and Reports, 1215 Jefferson Davis Highway, Suite 1204, Arlington, VA 22202-4302, and to the Office of Management and Budget, Paperwork Reduction Project (0704-0188), Washington, DC 20503.

1. AGENCY USE ONLY (Leave blank)		2. REPORT DATE January 1996	3. REPORT TYPE AND DATES COVERED Final - January 1995 - December 1995	
4. TITLE AND SUBTITLE USAF Dental Instrument Processing Center Design Guidance			5. FUNDING NUMBERS	
6. AUTHOR(S) John H. Hatfield James J. Kane Richard H. Blankman				
7. PERFORMING ORGANIZATION NAME(S) AND ADDRESS(ES) Armstrong Laboratory (AFMC) USAF Dental Investigation Service Aerospace Medicine Directorate 2509 Kennedy Circle Brooks Air Force Base, TX 78235-5117			8. PERFORMING ORGANIZATION REPORT NUMBER AL/AO-TR-1996-0006	
9. SPONSORING/MONITORING AGENCY NAMES(S) AND ADDRESS(ES)			10. SPONSORING/MONITORING AGENCY REPORT NUMBER	
11. SUPPLEMENTARY NOTES Phone Numbers: (210) 536-3502, DSN 240-3502				
12a. DISTRIBUTION/AVAILABILITY STATEMENT Approved for public release; distribution is unlimited.			12b. DISTRIBUTION CODE	
13. ABSTRACT (Maximum 200 words) This Design Guidance includes USAF dental clinic dental instrument processing center space planning and construction criteria inclusive of architectural, mechanical, and electrical design requirements.				
14. SUBJECT TERMS Architectural Construction criteria Dental instrument processing center design guidance			Design development Electrical Equipment Mechanical	Space planning
			15. NUMBER OF PAGES 44	
			16. PRICE CODE	
17. SECURITY CLASSIFICATION OF REPORT Unclassified	18. SECURITY CLASSIFICATION OF THIS PAGE Unclassified	19. SECURITY CLASSIFICATION OF ABSTRACT Unclassified	20. LIMITATION OF ABSTRACT UL	

Contents

	Page
1. Introduction	1
2. Overview--Concept	1
3. Instruments	2
4. Facility Sizing	6
5. Mechanical Requirements	7
6. Electrical Requirements	11
7. Equipment Requirements	11
8. Room Furnishings and Finishes	13
9. Central Instrument Processing Designs	13
10. References	28

List of Tables

Table No.

Table 1. Sterilizers: Pre-vacuum versus Gravity	4
Table 2. Equipment Heat Generation Information	9
Table 3. Equipment Heat generation Information	9

List of Figures

Figure No.

Figure 1: DIPC Schematic Floor Plans	6
Figure 2: Typical Casework Plans and Elevations	15
Figure 3: Small Dental Instrument Processing Center Floor Plan	16
Figure 4: Typical Dental Instrument Processing Center Equipment List	17
Figure 4a: Small Medium Dental Instrument Processing Center Floor Plan	18
Figure 4b: Medium Dental Instrument Processing Center Floor Plan	19
Figure 4c: Medium Dental Instrument Processing Center Floor Plan	20
Figure 4d: Medium Dental Instrument Processing Center Floor Plan	21
Figure 4e: Medium Dental Instrument Processing Center Floor Plan	22
Figure 4f: Medium Dental Instrument Processing Center Floor Plan	23
Figure 5a: Large Dental Instrument Processing Center Floor Plan	24
Figure 5b: Large Dental Instrument Processing Center Floor Plan	25
Figure 6a: Recommended 90 PSI Air Connection at Existing Air Outlets	26
in Sterilization Areas	
Figure 6b: Recommended 90 PSI Air Connection at New Air Outlets	27
in Sterilization Areas	

List of Appendixes

Appendixes

Appendix A: Step-by-Step Guide for Designing a Dental Instrument.....	29
Processing Center in a New or Existing Facility	
Appendix B: DIPC Information Check List	33

USAF Dental Instrument Processing Center Design Guidance

1. Introduction

1.1 A major goal of dental managers everywhere is to successfully decontaminate, process, and store dental instruments without percutaneous injury to dental personnel. While equipment is available to allow cleaning of dental instruments with minimal instrument handling, it is expensive. Centralization of dental instrument processing allows a more cost effective sharing of this equipment among all members of the dental staff. By doing so, clean, sterile instruments are provided while minimizing the risk of personal injury.

1.2 *USAF Dental Instrument Processing Center Design Guidance* is the Dental Investigation Service's current recommendation on how to most efficiently carry out central dental instrument processing in Air Force dental clinics. This includes decontamination, preparation, sterilization, and storage of instruments. It also provides guidance on how to develop a Dental Instrument Processing Center (DIPC) to support any size dental facility that will meet Joint Commission on Accreditation of Healthcare Organizations (JCAHO) requirements, Association for the Advancement of Medical Instrumentation (AAMI) Standards #35 and #42, 29 CFR 1910.1030, Centers for Disease Control and Prevention (CDC) Dental Infection Control Guidelines, Headquarters United States Air Force/Surgeon General Dental (HQ USAF/SGD) policy in DIS #37, and proposed Department of Defense (DOD) space and design criteria.

2. Overview--Concept

The simplest way to conceptualize central sterile design is to mentally go through the sterilization process from dental treatment room (DTR) through sterile pack or cassette. Throughout the process an effort is made to keep the decontamination and clean operations separated. Ideally, this is done by a physical barrier such as a wall with a pass-through window. Physical separation often is not possible. When physical separation is not possible, procedural separation is used. To obtain good procedural separation, equipment should be arranged in such a way that as an instrument or pack is brought through the process from contaminated to sterile, the path of the instrument never crosses back on itself. An example of how to do that is to have processing start just inside and immediately to the left of the door to the DIPC and proceed clockwise or left to right around the periphery of the room.

3. Instruments

3.1 Instrument Decontamination

The decontamination side is where instruments are received and decontaminated. This is the decontamination area and should have negative air balance if physical separation is used. Instruments are received here first after use and are decontaminated. The goal of the first step in the process is to produce clean and reasonably dry instruments, ready for assembly and sterilization, while minimizing the chance of percutaneous injury with a dirty instrument. After use, instruments need to be cleaned to reduce the bio-burden and permit effective sterilization. To avoid percutaneous injury, the process should be designed to minimize handling of instruments prior to decontamination. Several options are available for decontamination. Hand scrubbing is the least desirable method because of the risk of injury. Both tabletop and larger ultrasonic cleaning units that accept entire cassettes are available. Some models offer limited disinfection in addition to cleaning. No provision is typically made in ultrasonics for drying instruments. The best use for ultrasonics is to clean instruments with gross bioburden that may not be adequately cleaned by a washer/decontaminator. The best option where practical is to use a washer/decontaminator. This is basically an instrument washer designed to clean and in some cases thermally disinfect instruments placed in cassettes or baskets. Instruments are dried at the end of the cycle. Drying is important because instruments should be dry when they are bagged or wrapped. Washer/sterilizers are also available which provide a flash sterilization at the end of the cleaning cycle. However, they do not allow one to avoid the assembly and sterilization process as they only sterilize loose instruments that are not protected upon removal from this washer. Pass-through washer/decontaminators or washer/sterilizers are available for larger settings to provide optimum physical separation between clean and dirty work areas. Washer/decontaminators tend to clean instruments better than washer/sterilizers. The washers offer various options including: an alkaline wash to help remove blood and other proteins without heat coagulating them, an acid wash/rinse to further remove protein and mineral residues as well as neutralize the alkaline wash, a deionized water rinse for better drying, and/or instrument lubrication ('milk bath') to help reduce rusting during sterilization. The maximum allowable water hardness for water supplied to a washer is typically 5 grains per gallon or 85 milligrams/liter (mg/L). The water for a deionized water rinse should be further deionized with a maximum water resistivity of 200,000 to 1,000,000 ohms/centimeter (cm). The higher the resistivity, the more deionized the water is.

3.2 Instrument Preparation

Dry, clean, and preferably disinfected instruments are then delivered to the clean side for assembly and wrapping. AAMI Standards #35 and #42 state that physical separation of clean and dirty is preferable but that procedural (red line) separation is acceptable. While a physical barrier such as a wall with a pass-through is ideal, it is not essential. The main goal is to keep the two work areas separate. Decontamination is accomplished on the dirty side and assembly

and wrapping are accomplished on the clean side. Counter space is needed to assemble and wrap instrument cassettes or packs to prepare them for sterilization. If instruments are disinfected, gloves would not be necessary here, but if not, some Personal Protective Equipment (PPE) is still required. Assembled and wrapped instrument packages are then heat sterilized.

3.3 Instrument Sterilization

3.3.1 Although there are several methods of heat sterilization available, autoclaves are the most common. The key features to consider are chamber size, method of air displacement, and whether your facility can provide adequate electrical power. It is also important to ensure that your facility has an adequate supply of deionized or soft water when needed. The feed water should have a maximum hardness of 3-5 grains. Using hard water will greatly increase the number and frequencies of equipment failures, especially of steam generators.

3.3.2 Chamber size: Tabletop autoclaves range in size from 7" to 15" chambers. Free-standing autoclaves have chamber sizes from 16" to 24".

3.3.3 Air displacement: Displacement of air present in the chamber at the start of the cycle and replacement with steam is essential for sterilization. Tabletop sterilizers typically rely on the fact that steam is less dense than air and will rise above it. As steam is generated in the chamber, it rises up over the air and displaces it downward through a pin hole or valve in the bottom of the chamber. This continues until all the air is displaced and replaced by steam. This is called gravity displacement. Virtually all tabletop autoclaves and some free-standing autoclaves rely on gravity displacement. Other free-standing autoclaves have a pre-vacuum cycle that uses vacuum to remove the air from the chamber. A steam generator produces steam outside the chamber and has it ready and waiting. Together, pre-vacuum and a steam generator greatly speed the sterilization cycle. Thus, a free-standing, gravity displacement autoclave is expected to be slower and have lower throughput than a free-standing, vacuum displacement autoclave. If free-standing autoclaves are supplied, the vacuum models generate less wasted heat, process faster, and provide more reliably dry instrument sets because the quality of the steam in the chamber is better controlled. Table 1 summarizes pre-vacuum versus gravity differences.

Table 1. Sterilizers: Pre-vacuum versus Gravity	
Pre-vacuum	Gravity
Shorter cycle time, throughput almost doubled	Longer cycle time, lower throughput, longer turn-around times
Faster turn-around time.	Longer turn -around time.
No air pockets in chamber, less chance of incomplete sterilization. This is especially important for dense loads.	Potential for air pocket. Where ever there is air and not steam, sterilization does not occur
Heat loss to the room per hour is about the same but more cycles per hour so less heat per pack sterilized.	Heat loss to the room per hour is about the same but fewer packs sterilized during that hour.
Sterilizer size is the same.	Sterilizer size is the same.
May require slightly higher water pressure/supply. If Pre-vac is likely any time in the future, design utility requirements to Pre-vac, not gravity levels even if gravity sterilizer is initially installed.	Lower water pressure/supply requirements.
Higher cost, approximately \$2000-\$2500 higher cost.	Lower cost, saves \$2000 - \$2500. Can sometimes convert gravity to pre-vac sterilizer, cost varies.
Must run Bowie-Dick test either daily or weekly to ensure vacuum is working (an additional cost).	No vacuum testing requirements.

3.4 Instrument Storage and Transport

3.4.1 After sterilization, packs or cassettes need to either be stored on appropriate shelving or transported on mobile carts to a suitable, generally covered storage area. Clean storage may be located on the clean side, in the DTR, or in a separate storage room. Physical separation of sterile storage from the clean side of sterilization is not required. Contaminated or used instrument packs must be held in a different covered cabinet from clean storage although they can be co-located if covered in the workplace. The same carts can be used for transport of contaminated sets and sterilized sets to and from the workplace if they are disinfected before the use changes. This can be accomplished with either a steam gun or chemical wipe down.

3.4.2 Using different mobile carts for contaminated and sterilized instrument sets, is called a "Double Loop System". As a general rule, the contaminated instrument carts are circulated ("looped") around the clinics, picking up contaminated instrument sets in the DTRs, and then going to the Contaminated (Dirty) Side DIPC Room, emptied, and then returning back again to the DTRs, and so on. Carts are disinfected as needed, but not necessarily after each trip to the DIPC. This process defines the first loop in the Double Loop System. The same is true for the sterilized instrument carts, except that you are picking up sterilized instrument sets from the Sterilized (Clean) Side DIPC Room to be delivered to the DTRs and then returning the empty instrument carts back again to the Clean Side DIPC Room, which defines the second loop. There you have your "Double Loop" with contaminated instruments in one loop and sterilized instruments in the other. See schematic drawing below.

3.4.2.1 Advantages: Dirty carts are never used for sterile instruments; therefore, they do not have to be disinfected on each trip to the DIPC.

3.4.2.2 Disadvantages: Dirty carts must be brought back to the DTRs empty which creates for an extra trip.

3.4.3 Using the same mobile carts for both contaminated and sterilized instrument sets is called a "Single Loop System". In this process, the contaminated instrument sets are picked up from the DTRs in mobile carts and are taken to the Dirty Side DIPC Room. The contaminated instrument sets are removed from the carts and washed/decontaminated. The contaminated instrument carts are moved into a small cart wash room located between the Dirty and Clean Side DIPC Rooms. They are then disinfected and wiped down or steam gunned and dried, passed through to the Clean Side DIPC Room, and loaded up with sterilized instrument sets to be delivered to the DTRs. Thus, you have one single continual loop system. See schematic drawing below.

3.4.3.1 Advantages: Personnel can drop off of dirty cart and instruments and pick up of sterile instruments in a clean cart without extra trips.

3.4.3.2 Disadvantages: Dirty carts must be disinfected every time through the DIPC.

3.4.4 Steam Cart Wash Room Safety Requirements

3.4.4.1 For United States Air Force (USAF) bases, stations, and other properties:

3.4.4.1.1 Personal protective gear requirements: Follow Air Force Occupational Safety and Health (AFOSH) Standard 127-31, item 5. Basically, this requirement calls for personnel to wear protective gear inclusive of synthetic rubber or plastic gloves with a cotton fabric liner, single hearing protection as determined by the base Bioenvironmental

Engineering Office, full face shield, water resistant full body garment which covers the arms up to the gloves, water resistant boots with non-skid soles, and possible other protective items as required by base officials.

3.4.4.1.2. Cart Wash Room personnel training: Follow AFI 91-301, item 2.14.

3.4.4.2 For other than Air Force properties: Follow OSHA, 29 CFR 1910.

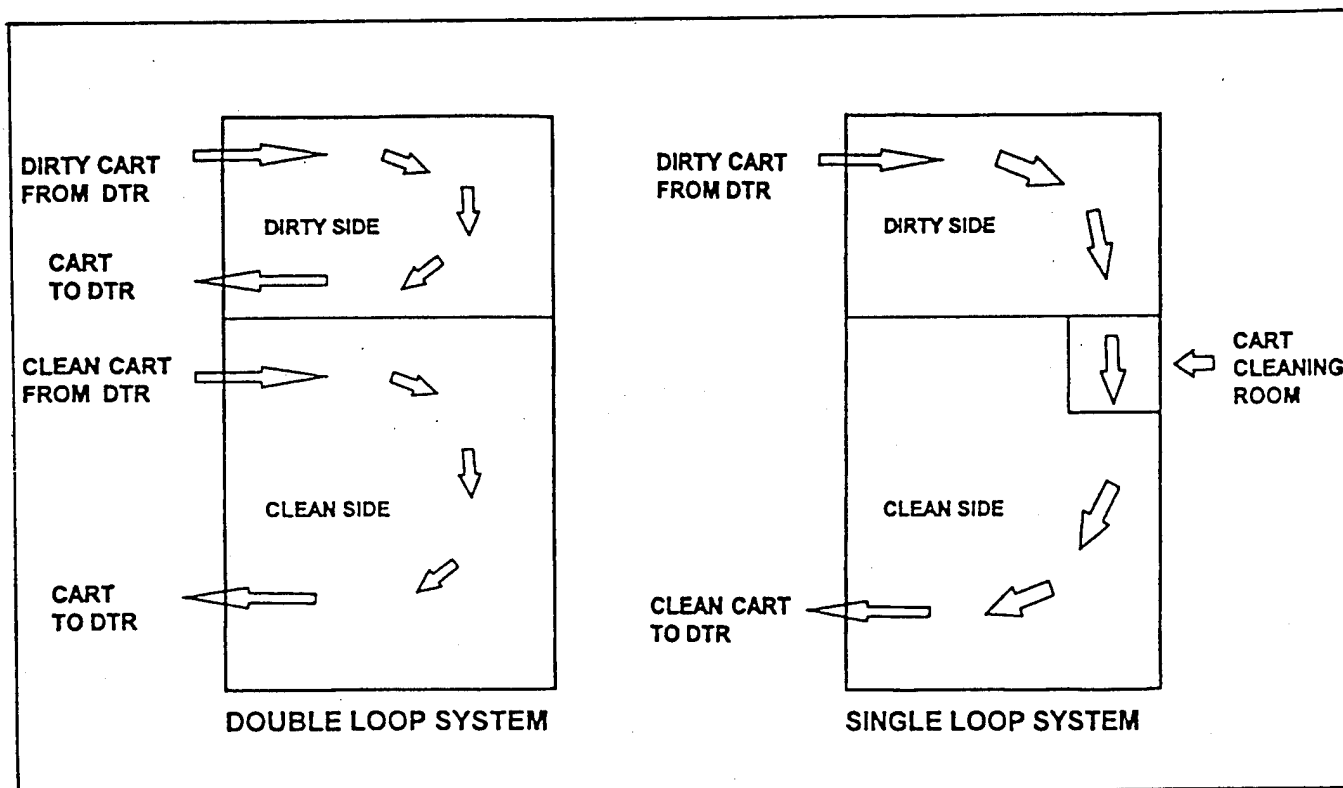

Figure 1: DIPC SCHEMATIC FLOOR PLANS
Not to Scale

4. Facility Sizing

4.1 Air Force DIPCs can be most efficiently sized using the following formula: Net Square Footage (NSF) = 140NSF + 11NSF X (No. of DTRs).

4.2 This area should be divided into a decontamination (dirty) room and clean processing room if possible. Physical separation of clean and dirty is recommended by AAMI Standards #35 and #42, but not absolutely required. Procedural separation of clean and dirty is allowable. The decontamination room will take 30% to 40% of the total area. Separation of

clean and sterile storage is optional and is not generally preferred as it is generally less efficient use of space. Current USAF design concept is to provide one DIPC per dental facility. Where dental clinics are co-located with medical treatment facilities (MTFs), sharing of the Central Supply Service is permissible where it is in reasonable proximity to and has adequate capacity for the dental user. DTR support areas are needed at 90NSF per 8 DTRs to support the treatment suites in the central processing concept. They are used primarily for holding cleaning and disposable supplies and contaminated dental instrument kits prior to transport to the DIPC.

5. Mechanical Requirements

5.1 The most common feedback we get from clinics currently operating DIPCs is that the room where the sterilizers are located gets too hot. This is especially a problem if personnel are required to wear personal protective equipment because decontamination and sterilization are done in the same room. The key to avoiding this problem is careful attention to air handling.

5.1.1 Definitions by example:

5.1.1.1 Air changes per hour or ACH: Every time a volume of air equal to the volume of the room is supplied to a room, one air change has happened. Air entering a room is called supply air. For example, a typical DTR may be 10' x 10' x 12' and receive 6 air changes per hour. This typical DTR has a room volume of 10' x 10' x 12' or 1200 cubic feet. If 6 air changes per hour are to occur in that room then over the course of one hour 1200 x 6 or 7,200 cubic feet of air need to be supplied to that room. The 7,200 cubic feet per hour can be converted to the more common cubic feet per minute or CFM by dividing by 60 giving a result of 120 CFM. By supplying 120 CFM of air to a 1200 cubic foot room, 6 air changes per hour are achieved.

Formulas for computing CFM and ACH:

$$\text{CFM} = \frac{\text{ACH} \times \text{Room Volume}}{60} \quad \text{ACH} = \frac{\text{CFM} \times 60}{\text{Room Volume}}$$

Ideally, a dental instrument processing center should have approximately 10 air changes per hour. This is the minimum required for normal health and comfort considerations. Additional air exchanges are likely to be required for heat removal. One can immediately see the potential problem of locating a dental instrument processing center in a former DTR or office originally designed for 6 or less air changes per hour.

5.1.1.2 Air balance: Air leaving a room is either exhausted outside or enters a return air duct and is eventually recirculated. A room has zero or neutral air balance when the supply air rate, or CFM of air supplied into the room, is exactly equal to the air exhausted and/or returned from the room.

5.1.1.3 Negative air balance: If more air is exhausted and/or returned from a room than supplied to it for a long enough period of time, the air pressure in the room would begin to drop. As the air pressure drops, and since the room is not sealed, air from hallways and surrounding rooms is drawn into the room. Thus when negative air balance is achieved there is a net air flow from surrounding areas into the room. Having net air flow into the room is desirable if you wish to prevent air borne bacteria present in the room from escaping. For this reason on the decontamination side of a DIPC, negative air balance is desired. A minimum of 10% more air should be exhausted or returned from the room than air supplied to it.

5.1.1.4 Positive air balance: If more air is supplied to a room than exhausted or returned from it for a long enough period of time, the air pressure in the room would begin to rise. As it does, air flows out of the room into surrounding areas. This net air flow out of the room prevents bacteria from surrounding dirtier areas from flowing into a room with positive air balance. The clean side of a dental instrument processing center should have positive air balance to produce a net air flow out of the room and prevent bacterial from entering the room. Typically the clean side should have 10% more air supplied to the room than exhausted or returned from it to produce positive air balance.

5.1.2 Air handling requirements for DIPCs: The air handling requirements conform to guidelines previously established for central sterile supply. Both clean and dirty rooms require 10 ACH with 25% new air. Positive air pressure balance is required on the clean side and negative air pressure balance is required on the dirty side. If both clean and decontamination operations are conducted in the same room with procedural separation, neutral to slightly negative air balance is preferred.

5.1.3 Additional air requirements due to heat generation: Many pieces of equipment in a dental instrument processing center generate significant quantities of heat especially on the clean side. This heat must be carried away by exhausting hot air and supplying cooler air. The higher the number of air changes per hour, the more heat that can be carried away. Generally greater than 10 ACH are needed to carry away enough heat to keep the room at the proper temperature.

5.1.3.1 Ideally, in a multi-zone air handling system, the clean side of a dental instrument processing center should be an independent zone. This will allow supplying enough cooled air to the clean side without freezing out anyone else. The thermostat on the clean side should only control air flow and air temperature to the clean side.

5.1.3.2 In order to be sure the air handling system is properly designed so reasonable temperature can be maintained, estimate the amount of heat that will be generated on the clean and decontamination side of your dental instrument processing center. Heat generation is typically measured in British Thermal Units per Hour (BTU/Hr). You can

determine how many BTU/Hr a piece of equipment generates either from a technical or specification sheet about the equipment or by calling the company. This information is readily available. Table 2 and 3 show some typical values for a small 10 DTR dental instrument processing center with a dishwasher size thermodisinfectant on the decontamination side, and both a free standing 16" cabinet sterilizer and a 10" table top autoclave on the clean side.

Table 2. Equipment Heat Generation Information			
Equipment	Typical Heat Generation in BTU/Hr	Decon Side	Clean Side
Dishwasher size thermodisinfectant	1000 BTU/Hr	1000 BTU/Hr	
10" table top autoclave	500 BTU/Hr		500 BTU/Hr
16" Cabinet free standing sterilizer	4500 BTU/Hr		4500 BTU/Hr
Totals:		1000 BTU/Hr	5000 BTU/Hr

An estimate such as this example should be given to who ever is designing your air handling system. The heat generated by the equipment you install is readily available on "catalog cut sheets" from the manufacturer.

One way to greatly reduce the air handling requirements on the clean side is to recess the sterilizer in a wall or closet rather than have it standing free in the clean room. When a sterilizer is recessed in a closet about half of the heat generated remains in the closet. The temperature in the closet can be allowed to rise to 100°F and acts like a heat sink.

Table 3. Equipment Heat Generation Information			
Equipment	Typical heat generated in BTU/Hr	Sterilizer closet with exhaust fan to outside	Clean room
10" table top autoclave	500 BTU/Hr		500 BTU/Hr
16" recessed sterilizer	4500 BTU/Hr	2500 BTU/Hr	2000 BTU/Hr
Totals:		2500 BTU/Hr	2500 BTU/Hr

In this simple example by trapping heat in the sterilizer closet and providing an exhaust fan to the outside in the sterilizer closet, the heat released to the clean room is cut in half. An exhaust fan or hood should be placed in the closet to exhaust a sufficient amount of hot air to limit the temperature in the closet to 100°F. The capacity of the fan/hood in CFM required can be calculated based the number of BTU/Hr released in the sterilizer closet and the temperature of the air in the clean room just outside the sterilizer closet. In this example, assuming the temperature in the clean room was being maintained at 80°F and the temperature in the sterilizer closet could rise to 100°F, a 150 CFM exhaust system would be sufficient for the 2500 BTU/Hr generated in the sterilizer closet. If the temperature in the clean room was above 80°F, then a larger exhaust system would be needed to keep the temperature in the sterilizer closet at or below 100°F

5.2 Domestic hot and cold water are required to both sides of the complex. Water supplied to equipment must be soft water. If hard water is supplied, scale will build up inside the equipment and cause break down. A typical requirement is less than 5 grains per gallon or 85 mg/L of hardness. Your local plant manager or Bioenvironmental Engineer can tell you the degree of hardness of the water in your facility or measure it for you. Obtaining soft water may require addition of a water softener if your facility does not already have one. Some equipment, especially steam generators and the deionized rise cycle in washers, may require further deionization of the feed water. A handwashing sink is required on the dirty side and is permissible on the clean side.

5.3 Some equipment may discharge water hotter than 200°F. In most locations local plumbing codes require a temperature regulating valve to mix additional cold water in with the hot water to bring the temperature below 200°F prior to entering the sewer system. Many sterilizers have thermal pollution protection built-in.

5.4 Most sterilizers with intergral steam generators require backflow preventers to stop water in the steam generator from backing up into the water supply line according to Air Force Instruction (AFI) 32-1066. Unfortunately, most sterilizers do not come equipped with backflow preventers. On any sterilizer not equipped with a backflow preventer, one will have to be installed by a plumbing contractor when the sterilizer is installed.

5.5 If available, medical high pressure steam is the cheapest method of supplying autoclaves, instrument washers, and ultrasonic rinsers/driers with heat. It is also the best method of heating water distillers. If no house steam source is available, most larger instrument washers will require a separate steam generator. A steam gun, used to disinfect instrument carts, is another useful piece of accessory equipment. Built-in autoclaves require either a steam source or an integral steam generator. The water sources to steam generators, autoclaves, and instrument washers should be treated to remove chemical and mineral impurities to both improve the quality of the steam and to prevent scale formation from causing the equipment to fail. As follows, several methods of obtaining steam are available:

5.5.1 High quality pure piped steam - goes directly into the chamber. 50-80 pounds per square inch guage (PSIG) pressure, 97%-100% Vapor quality, flow rate 120-80 pounds per hour (lbs/hr) peak demand and 90-35 lbs/hr average. Exact flow rates depend on the size of the sterilizer. Using high quality pure piped steam reduces electrical requirements. Chemical, particulate, and moisture content of the steam source must be considered for medical steam. If amines are added to the steam at the boiler plant to reduce boiler and pipe rust, do not use the steam for sterilization unless the amines are well regulated per recommendations of the American Hospital Association (AHA), Steam Purity: Resolving Observed Problems, 1985 and at or below levels set by the Food and Drug Administration (FDA), 21 Code of Federal regulations (CFR) 173.315.

5.5.2 Lower quality piped steam - The steam is used as a heat source to boil water and produce purer steam. The piped steam does not enter the chamber. This requires a supply of softened, pure water as well as the steam to heat it. Steam requirements are variable. A steam heated steam generator is less expensive to operate than a electrically heated steam generator. This type of steam is suitable to heat water in an instrument washer such as the MDT Corporation's 7550 instrument washer with the steam coil option.

5.5.3 Electrically heated steam generator - This uses electricity to heat softened, pure water to produce the steam that enters the chamber. No steam source is required but electricity and a pure water source is required. Typical requirements for pure water are less than 200,000 to 1,000,000 ohms/centimeter (cm) specific resistivity. An integral steam generator is one that is located in a particular piece of equipment and only supplies steam to that piece of equipment. Another alternative is to buy a separate steam generator that supplies steam to several pieces of equipment. It is usually located in a mechanical room.

5.6 Dental compressed air (90 PSIG) is desirable on both sides of the complex for handpiece purging. Vacuum is generally not required. See Figure 4 and 4a attachment which discribes the required type quick disconnect to be used in DIPC's.

6. Electrical Requirements

Electrical requirements will be substantial on both sides of the complex. Power for the sterilizers and related instrumentation will be affected by whether or not a steam source is available. In each case, electrical requirements must be customized for the equipment selected. Sterilizer closets need convenience outlets for repair work. Convenience outlets should also be located at a maximum spacing of 4'-0" o.c. on the backwalls of all DIPC counter tops.

7. Equipment Requirements

7.1 Instrument Cassette Systems

7.1.1 An instrument tray or cassette system must be selected by the user. They are available in a variety of sizes, shapes, and features for dental instrument processing but should be standardized as much as possible for each type of dental treatment. A variety of labelling options are also available. Central processing without cassettes or baskets of some type will result in lost instruments and incomplete kits. Cassettes also reduce the chance of percutaneous injury while handling instruments.

7.1.2 Once the cassette system has been selected, a rule of thumb to determine the appropriate number of cassettes is 10 per DTR in service per 8-hour day.

7.1.3 The Bloodborne Pathogens Standard requires automated processing of dental instruments; scrubbing them by hand is strongly discouraged.

7.2 Some capacity for ultrasonic cleaning is needed in all facilities on the decon (dirty) side. Since most small clinics (i.e., fewer than 10 DTRs) will depend on ultrasonic instrument cleaning, plans must include provision for adequate counter space for drying instruments. An automated ultrasonic cleaner with a rinser/drier cycle can reduce the amount of counter space needed, however it is important to note that these units may be rather large and require more space than typical ultrasonic cleaners. If you do not plan to use an automated instrument washer, you must plan on purchasing an adequate number of ultrasonic cleaners. Don't skimp on the number of ultrasonic cleaners you purchase. Some ultrasonic cleaning capacity is desirable on the clean side. Although most instruments should be clean by the time they get there, there may be situations when you need to use an ultrasonic cleaner to re-clean an instrument on the clean side.

7.3 Dental Investigation Service (DIS) firmly believes that clinics of more than 10 DTRs can most efficiently process instruments with one or more instrument washers. Thermal disinfection, which makes the instruments safe to handle without wearing PPE, is an advantage. The thermal disinfectant can be incorporated into a pass-through design between a dirty room and a clean room. It can also be located on the dirty side depending on space, capacity, and funding. In a crude sense, this device is a dishwasher for instruments in cassettes or baskets. Many of them are large pieces of medical equipment, look much like sterilizers, and are available as built-in units from sterilizer companies. Some are also available which look like dishwashers and fit under existing counters. We do not recommend the more expensive "washer/sterilizers" for dental use. Because these units were designed as sterilizers first and washers second, they may actually bake debris onto the instruments during their flash cycle. Instrument washers come in sizes and capacities that are similar to built-in terminal steam autoclaves. At least one dishwasher-type cleaner is currently marketed in the United States and has FDA approval as a thermal disinfectant. These units should be sized and purchased based on projected workload. Larger clinics will require larger units.

7.4 Plan to have terminal heat sterilizers with adequate capacity. Steam is a tried and true method and has proven to be versatile and economical for heat sterilization of dental instruments. DIS recommends that built-in vacuum steam autoclaves of adequate capacity be used where practical for clinics having more than 10 DTRs. If tabletop sterilizers are used, autoclaves are preferred as the primary sterilization method for environmental and economic reasons. A distilled or treated water source must be provided. Some dental instruments may be better sterilized with dry heat. Because of this, supplementary dry heat sterilization is often supplied in our designs. Chemical vapor sterilizers remain an acceptable alternative where recurrently in use if they are used in a well-ventilated area with chemipurges and hoods. They are, however, fast becoming cost prohibitive to operate and DIS does not recommend they be procured as replacement sterilizers in USAF designs.

8. Room Furnishings and Finishes

8.1 Floors should normally be seamless vinyl without backing with heat welded seams. If drains are included, as in cart wash areas, quarry tile should be considered.

8.2 Walls should be gypsum wallboard painted with waterproof, washable paint. The same would apply for the ceilings. In cart wash areas, ceramic tile walls should be considered.

8.3 Fixed, enameled steel casework or modular, medical casework is acceptable in DIPCs and DTR support areas. Stainless steel sinks, counter tops, and plumbing fixtures are preferred. In the standard USAF dental design guidance, we use modular "sea lockers" for cassette storage and transport to and from the DTR supports. Fixed and modular casework is used for storage of supplies. The processed instruments are stored in cassettes in the DTR casework prior to patient treatment.

8.4 Since instruments are processed in a dental instrument processing center, lighting should be adequate, approximately 70 foot-candles. Sterilizer closets also need about 70 foot candles of light to permit repair when needed.

9. Central Instrument Processing Designs

9.1 DIPCs are divided into three sizes for small, medium, and large clinics. Small clinics have fewer than 10 DTRs, medium have 10 to 30 DTRs, and large have more than 30 DTRs. Within each grouping, equipment and room sizes may vary. See Appendix A for a step by step design guide for DIPCs in new or existing dental clinics or medical facilities.

Most of the examples of DIPC drawings shown herein are taken from existing facility real projects that only had limited building space to offer; consequently, many of the project floor plans are undersized and do not meet the ideal formulated design net square feet (NSF) criteria

discussed in this design guidance. For every project, DIS tries to develop the best DIPC design that it can within the limits of the space allocated by the facility's user.

9.1.1 Figure 2 shows typical layouts of recommended minimum casework plans and elevations for contaminated side and clean side DIPC rooms.

9.1.2 Figure 3 is a layout for a typical small clinic. In a small clinic, physical separation of clean and dirty is usually not needed, storage space is less, and a small undercounter instrument washer will usually be supplied. Included in Figure 3 is a Miele Thermodisinfector, the smallest and most inexpensive instrument washer currently available. One or more Miele thermodisinfectors Model G7781 have proven to be effective in clinics of up to 18 DTRs.

9.1.3. Joint Services Number (JSN) listings shown are from Military Handbook 1691E (MIL-HDBK-1691E) and Military Specification Mil C 20709 D unless otherwise noted. An equipment list with brief descriptions is shown on the figure 3. Figure 4 provides an equipment list brief of most equipment items shown on all other attached drawing figures.

9.1.4 Figure 4a, 4b, 4c, 4d, 4e and 4f are layouts for typical medium size clinic DIPCs. In a medium clinic, instrument washers and DTR support areas are usually supplied. Physical separation of clean and dirty is usually attainable. No cart wash area is generally supplied. This type layout uses house steam. If none is available, steam can be provided by an intergral steam generator located under the sterilizer, which is less economical using power supplied by larger electrical lines. A complex specific steam generator may also be used.

9.1.5 Figure 5a and 5b are layouts for typical large clinic DIPCs. They are similar to that for a medium size clinic except that they are larger and usually contain a manual cart wash. Again this complex is supplied by house steam but alternative methods are available as described above. Cart wash areas require a steam source and drain.

9.1.6 Figure 6a is a detailed drawing of a recommended 90 PSI air connection for existing air outlets in sterilization areas, and figure 6b is a detailed drawing of a recommended 90 PSI air connection for new air outlets in sterilization areas.

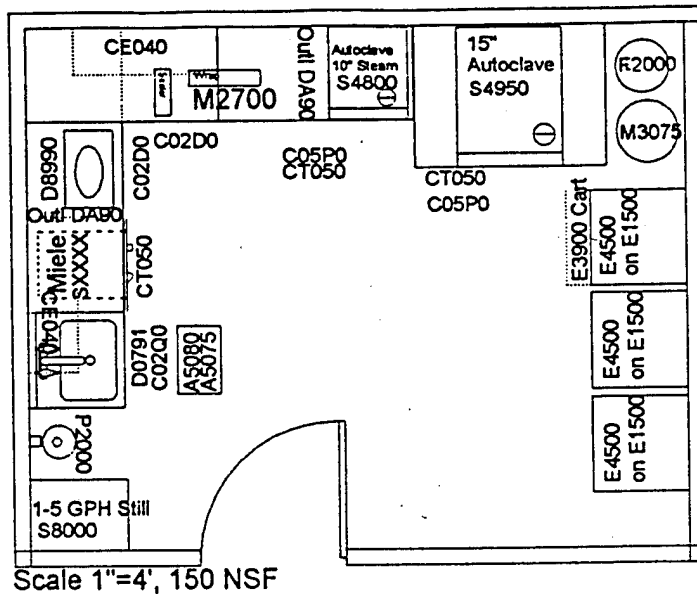

Small DIPC Floor Plan

Equipment List

- Outl DA90 - 90 PSI Air for Handpiece Purge
- S8000 - 1 GPH Electric Still(May require 5 GPH for Clean Water Systems)
- S0127 - 16" x 16" x 26" Vacuum, Electric Sterilizer
- S4800 - 10" Electric Sterilizer
- SXXXX - Miele Under Counter Thermodisinfectior
- CT050 - Stainless Steel Counter Top
- E4500 - Modular Sea-Locker (66x23x20)
- E3900 - Sea-Locker Transport Cart
- E1500 - Wall Hung Rail for Sea Lockers
- A5080 - Paper Towel Dispenser
- A5075 - Soap Dispenser
- D8990 - Dental Ultrasonic Cleaner
- D0791 - 10 x 14 x 14 Stainless Steel Sink
- C02Q0 - 36 x 24 x 22 Under Sink, Steel Cab, with Door
- C02D0 - 36 x 24 x 22 Steel Cab, SH, DO
- CO5P0 - 36 x 48 x 22 Under Sink, 2DO, SH Steel Cab
- CE040 - 30 x 36 x 13 Wall Hung Cab, 2 Glass Doors,SH
- M3075 - Hamper (Dirty Linen)
- F2000 - Waste Basket
- A5145 - Coat Hooks
- MXXXX - Sharps Disposal / Med Waste
- S4320 - 22" Insurment Washer
- S4330 - 26" Instrument Washer
- S18XX - Steam Generator (Size by Capacity)
- S0820 - 20 x 20 x 38 Cabinet Steam Autoclave(1691D)
- S0235 - 20 x 20 x 38 Recessed 2 DO Steam Autoclave
- S2635 - 37 x 30 x 23 Floor Standing Ultrasonic Cleaner

These JSN's apply to all figures and are from Mil Std 1691E unless otherwise indicated. All fixed casework is from Mil C-20709D in all figures.

Figure 3: Small Dental Instrument Processing Center Floor Plan

MIL HDBK 1691E JSN Typical DIPC Equipment List

JSN	Description
A5075	DISPENSER, SOAP, DISPOSABLE
A5080	DISPENSER, PAPER TOWEL, WALL MOUNTED
A5145	HOOK, ROBE, 2 PRONG
C0035	RAIL, APRON, 5.5X24X22
C0036	RAIL, APRON, 5.5X30X22
C0037	RAIL, APRON, 5.5X36X22
C01B0	CABINET, U/C/B, DO, 2SH, 36X18X22
C01D0	CABINET, U/C/B, 4DR, 36X18X22
C02C0	CABINET, U/C/B, DO, DR, SH, 36X24X22
C02D0	CABINET, U/C/B, 4DR, 36X24X22
C02Q0	CABINET, U/C/B, SINK, DO, 36X24X22
C03G0	CABINET, U/C/B, 2DO, 2SH, 36X30X22
C03H0	CABINET, U/C/B, 3DR, 2HDR, 36X30X22
C03P0	CABINET, U/C/B, SINK, 2DO, 36X30X22
C04G0	CABINET, U/C/B, 2DO, 2SH, 36X36X22
C04P0	CABINET, U/C/B, SINK, 2DO, 36X36X22
C05G0	CABINET, U/C/B, 2DO, 2SH, 36X48X22
C05P0	CABINET, U/C/B, SINK, 2DO, 36X48X22
CE030	CABINET, W/H, 2GDO, 2SH, 30X30X13
CE040	CABINET, W/H, 2GDO, 2SH, 30X36X13
CT050	COUNTERTOP, CRS,
D0791	SINK, SS, 18 GAUGE, 10X14X14
D0795	SINK, CRS, 18 GA, 10X14X10, FOOT CONTROL
D0800	SINK, SS, 12X20X16
D8990	CLEANER, ULTRASONIC
E1500	RAIL, MOD, W/MNTD, HX144XD
E3900	CART, TRANSPORT, 1 LOCKER, 42X28X26
E4500	LOCKER, STORAGE, MOD, R/H, 66X23X20
F2000	BASKET, WASTEPAPER, ROUND, METAL, 18X16DIA
M2700	SEALER, HEAT, PLASTIC BAG, W/MTR, PORT
M3070	HAMPER, LINEN, MOBILE
P1960	STATION, WASH, EYE/FACE, COUNTER TOP
S0125	STERILIZER, STEAM, VAC, DO, CAB, 16X16X26
S0230	STERILIZER, STEAM, VAC, DO, RCSD, 20X20X38
S4325	WASHER (MDT 7550), HW, 2DO, 24X26X25
S4800	STERILIZER, INSTRUMENT, ELEC, CTR/MNTD
S8000	STILL, WATER, ELECTRIC, 1GPH
S8100	STILL, WATER, ELECTRIC, 3GPH

Figure 4: Typical Dental Instrument Processing Center Equipment List

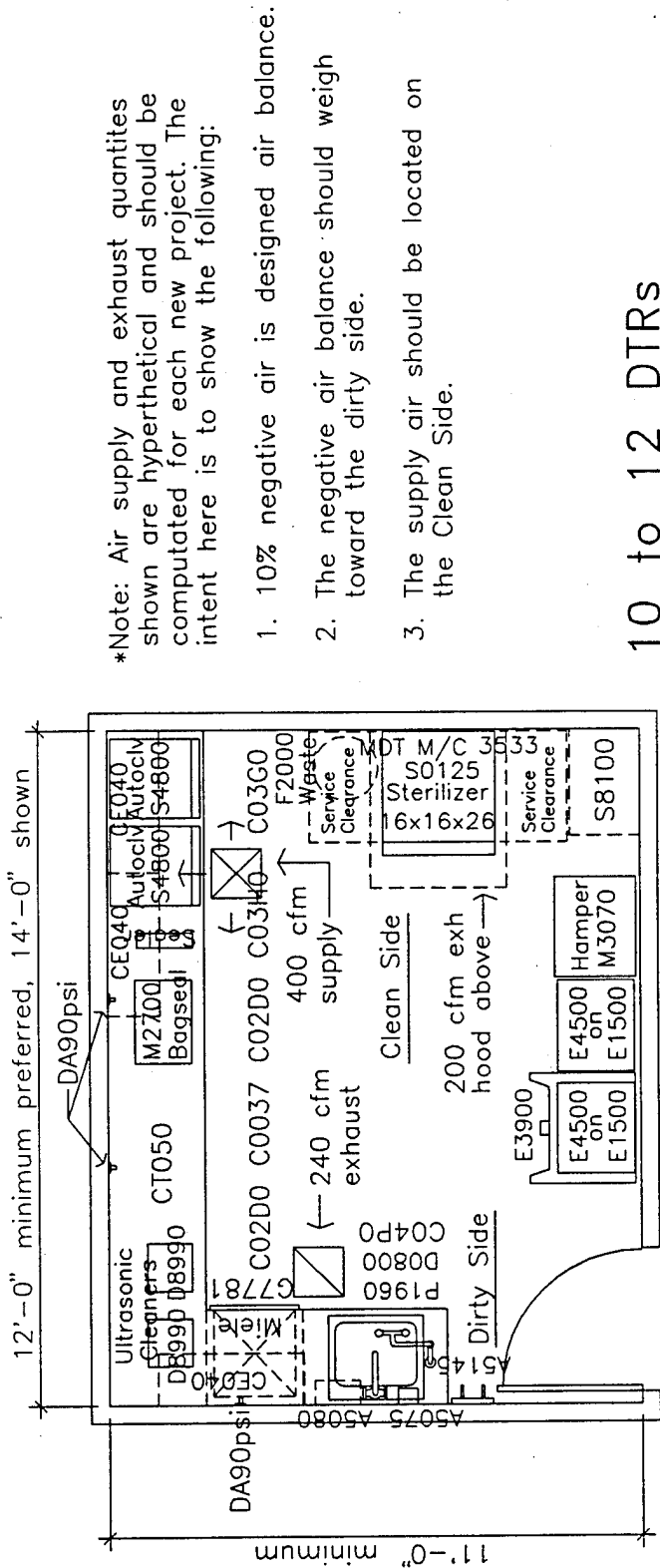

*Note: Air supply and exhaust quantites shown are hypothetical and should be computed for each new project. The intent here is to show the following:

1. 10% negative air is designed air balance.
2. The negative air balance should weigh toward the dirty side.
3. The supply air should be located on the Clean Side.

10 to 12 DTRS

Small Medium DIPC Floor Plan

Scale: 1/4" = 1'-0"

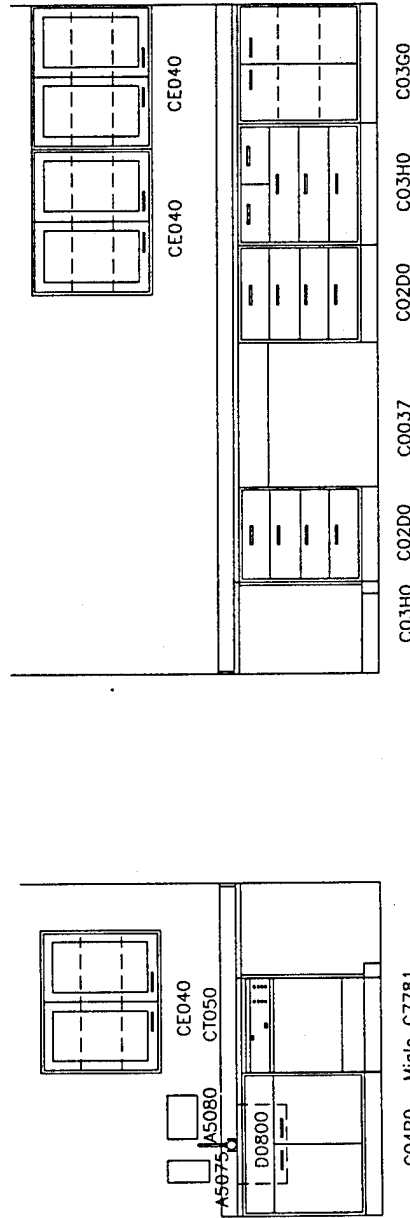

Clean Side Casework Elevation

Scale: 1/4" = 1'-0"

Contaminated Side Casework Elevation

Scale: 1/4" = 1'-0"

Figure 4a: Small Medium Dental Instrument Processing Center Floor Plan

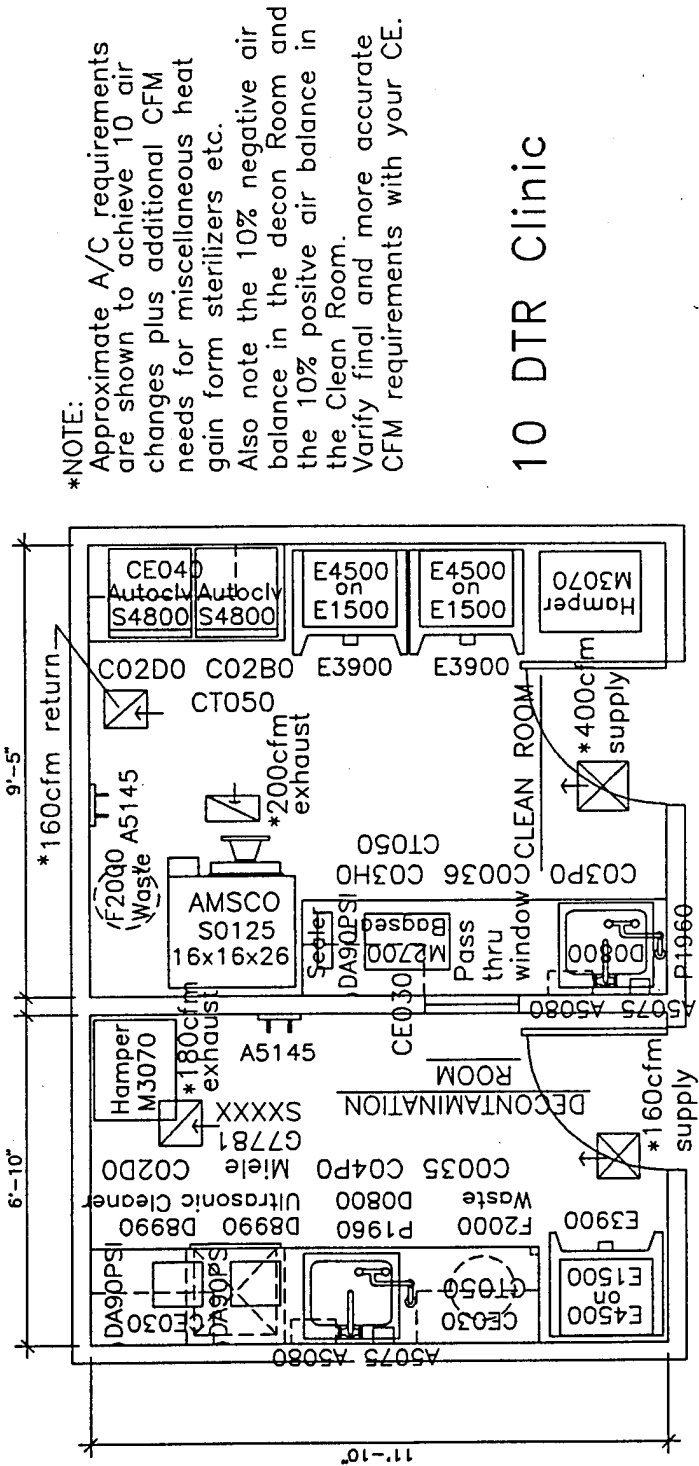

***NOTE:**
 Approximate A/C requirements are shown to achieve 10 air changes plus additional CFM needs for miscellaneous heat gain from sterilizers etc.
 Also note the 10% negative air balance in the decon Room and the 10% positive air balance in the Clean Room.
 Vary final and more accurate CFM requirements with your CE.

10 DTR Clinic

Proposed Floor Plan for DIPC F.E.Warren AFB, WY

1/4" = 1'-0"

Scale:

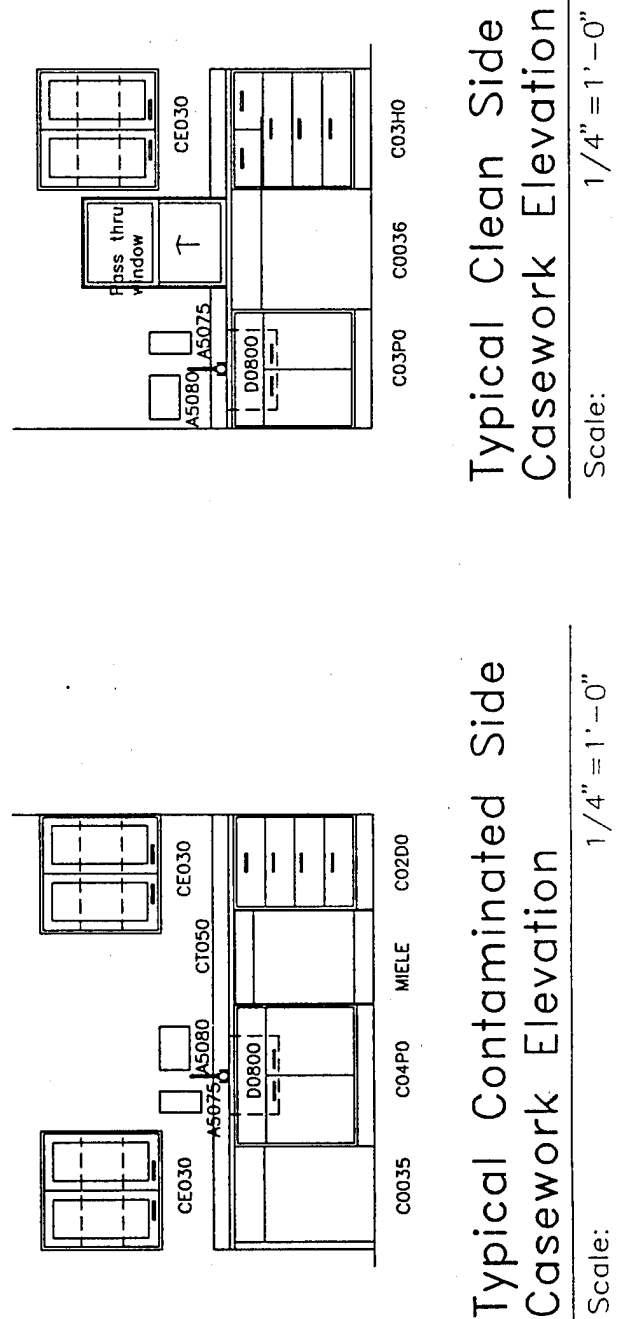
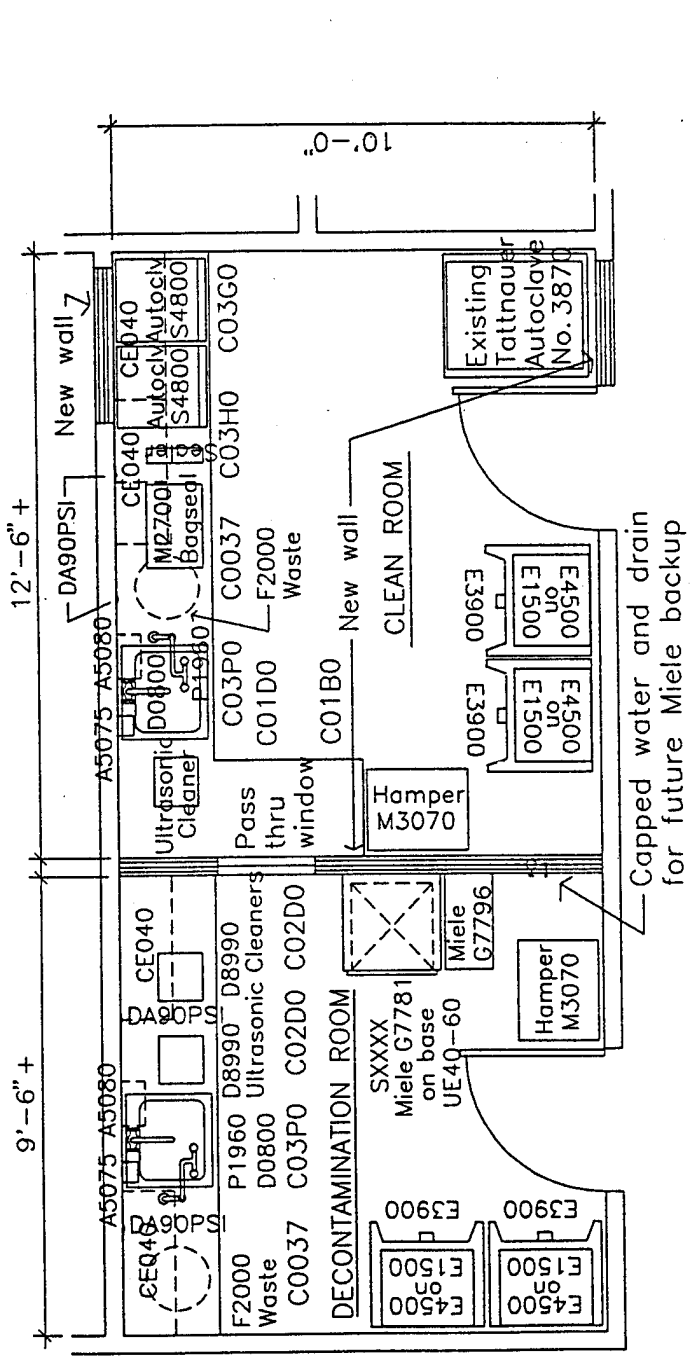
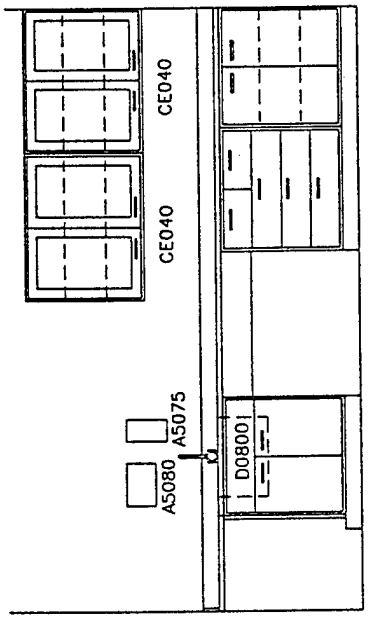

Figure 4b: Medium Dental Instrument Processing Center Floor Plan



Proposed Floor Plan of DIPC for Whiteman AFB, MO.

EXISTING ROOM 1064 Scale: 1/4" = 1'-0"



Typical Contaminated Side Casework Elevation Scale: 1/4" = 1'-0"

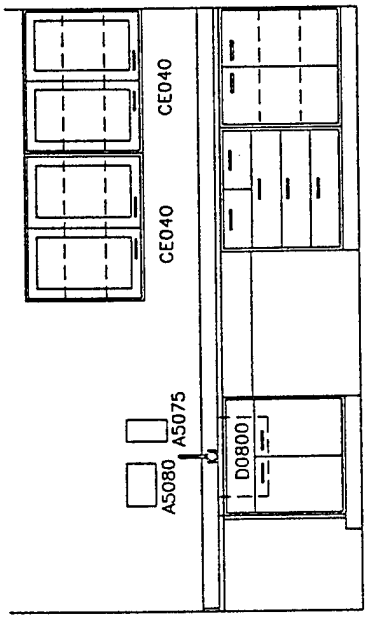

Typical Clean Side Casework Elevation Scale: 1/4" = 1'-0"

Figure 4c: Medium Dental Instrument Processing Center Floor Plan

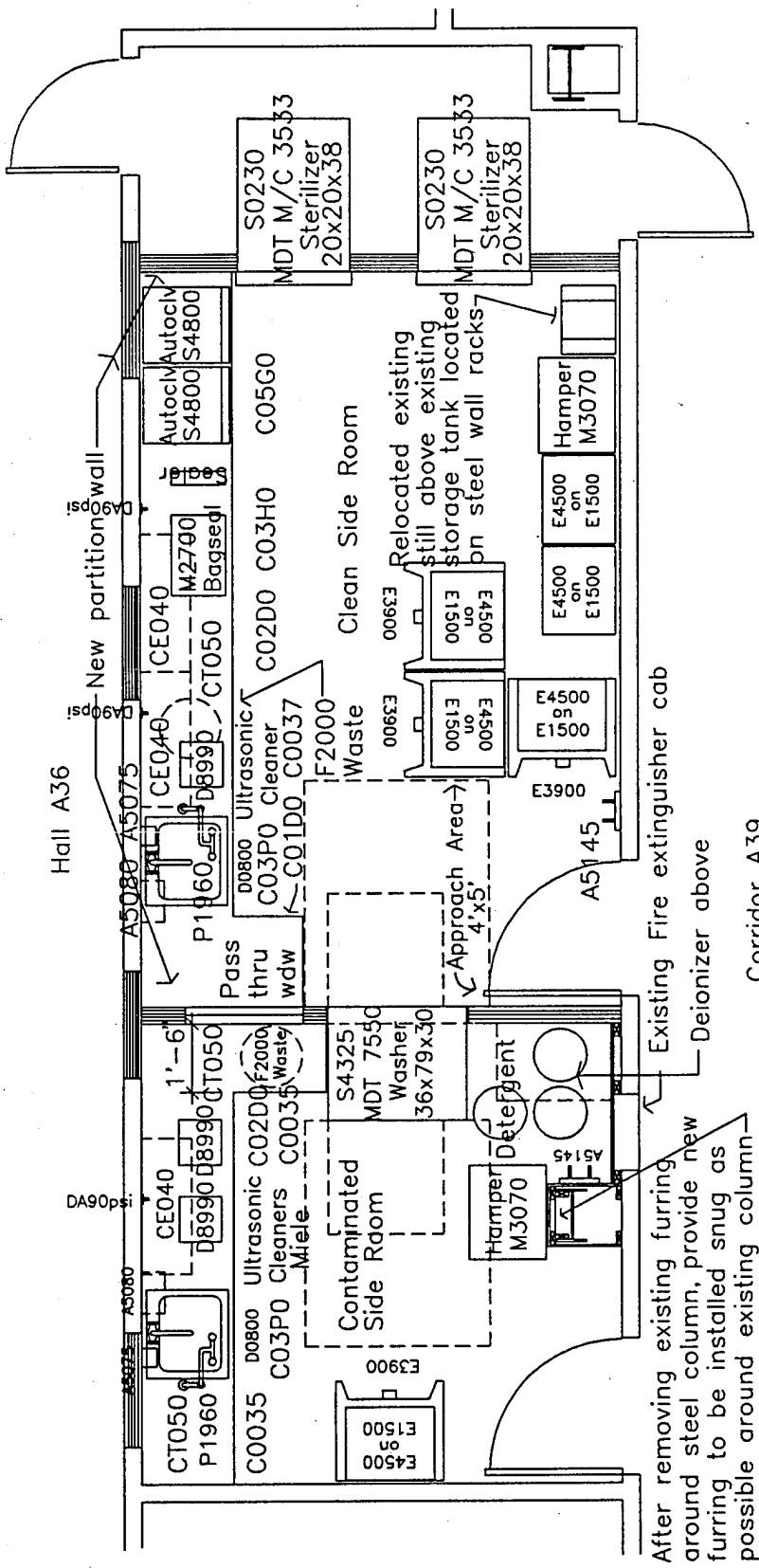

Floor Plan of Proposed DIPC for Dental Clinic at Scott AFB, IL.

Scale: 1/4" = 1'-0"

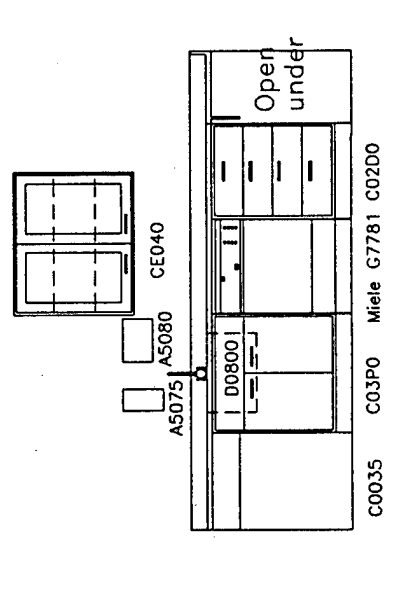
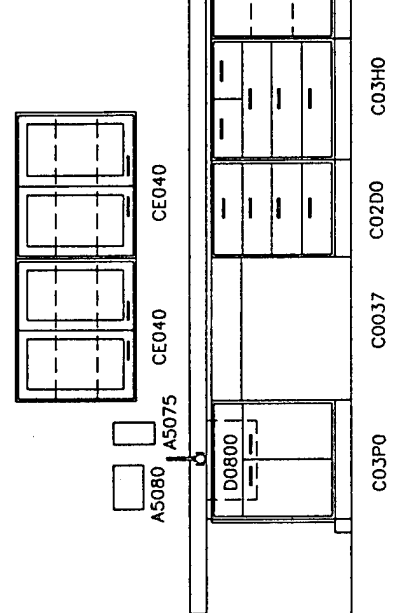
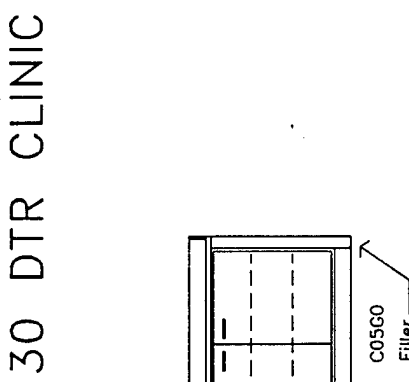

Scale: 1/4" = 1'-0"

Scale: 1/4" = 1'-0"

Scale: 1/4" = 1'-0"

Figure 4e: Medium Dental Instrument Processing Center Floor Plan

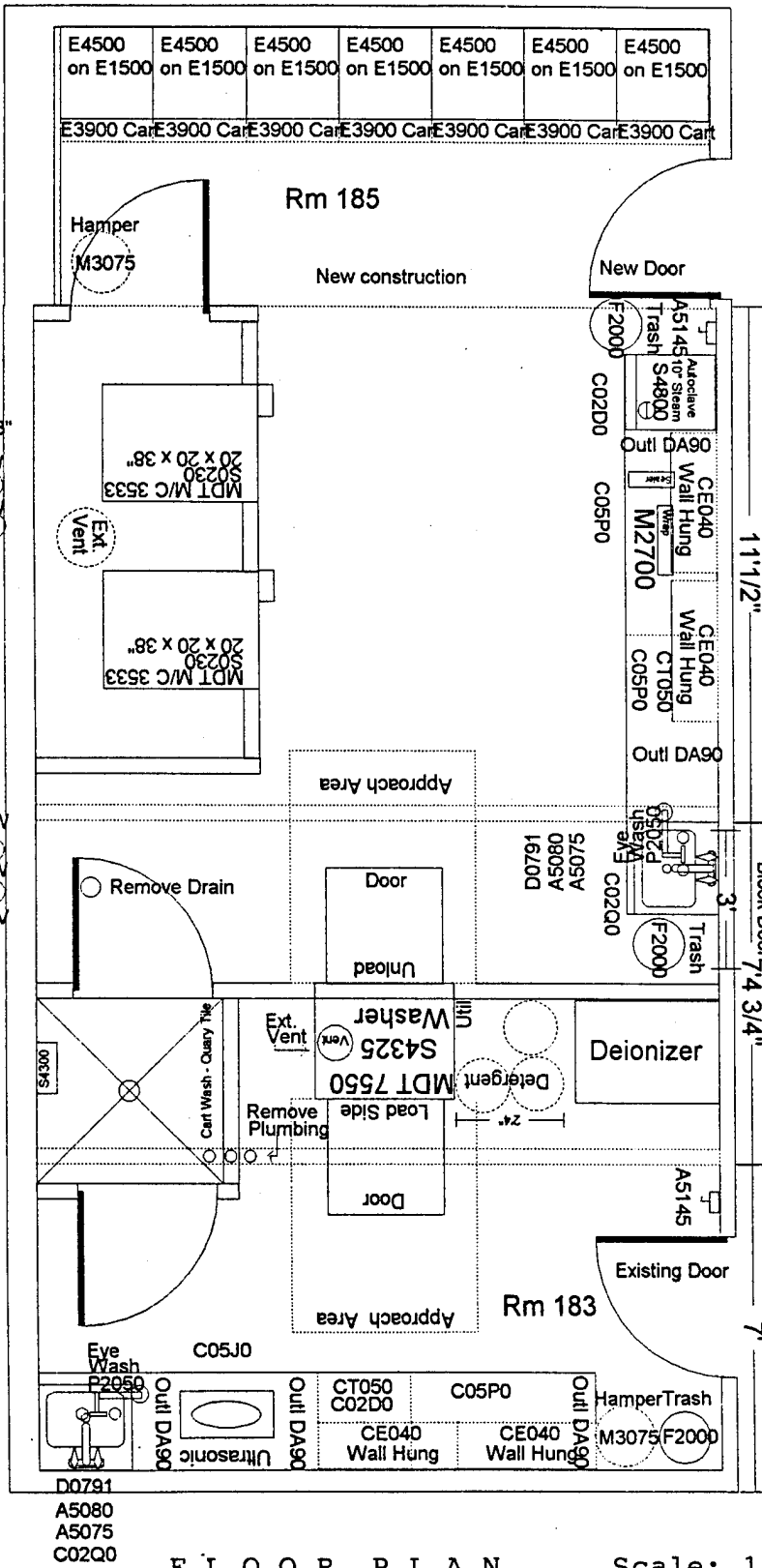

- S4800 - 10" Electric Sterilizer
- CT050 - Stainless Steel Counter Top
- E4500 - Modular Sea-Locker (66x23x20)
- E3900 - Sea-Locker Transport Cart
- E1500 - Wall Hung Rail for Sea Lockers
- A5080 - Paper Towel Dispenser
- A5075 - Soap Dispenser
- D8990 - Dental Ultrasonic Cleaner
- D0791 - 10 x 14 x 14 Stainless Steel Sink
- C02Q0 - 36 x 24 x 22 Under Sink, Steel Cabinet
- C02D0 - 36 x 24 x 22 Steel Cab, SH, DO
- CO5P0 - 36 x 48 x 22 Under Sink, 2DO
- CE040 - 30x36 x13 Wall Hung, 2 Glass Doors
- M3075 - Hamper (Dirty Linen)
- F2000 - Waste Basket
- A5145 - Coat Hooks
- S4325 - Instrument Washer
- S18XX - Steam Generator (Size by Capacity)
- S0230 - 20 x 20 x 38 Recessed Steam Autoclave
- P2050 Eyewash, Counter Mount

These JSN's are from Mil Std 1691E.
All fixed casework is from Mil C-20709D

Barksdale AFB

21 Oct 94

30 DTR CLINIC

FLOOR PLAN Scale: 1/4"=1'-0"

Figure 4f: Medium Dental Instrument Processing Center Floor Plan

CORRIDOR 2G-C2

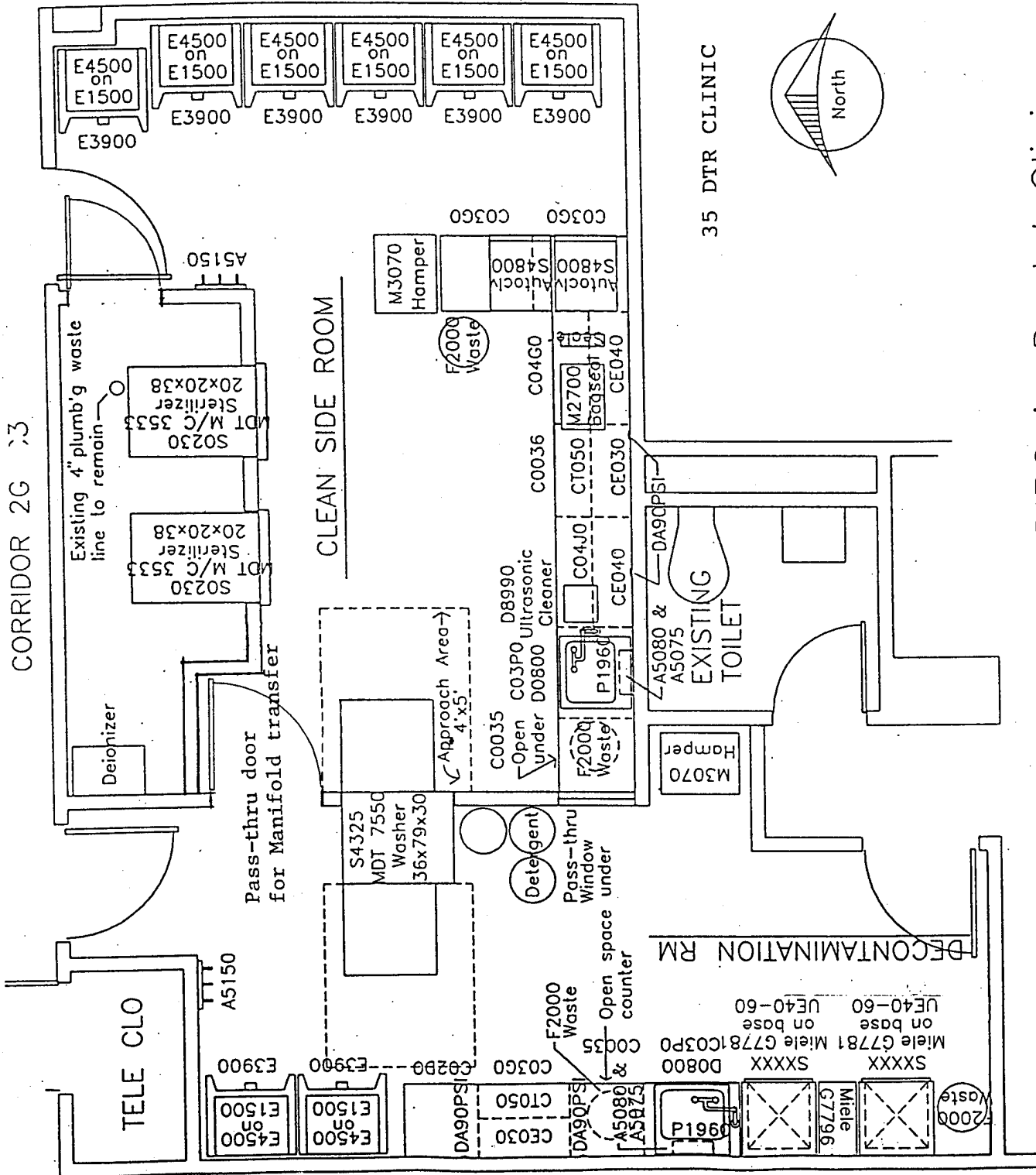
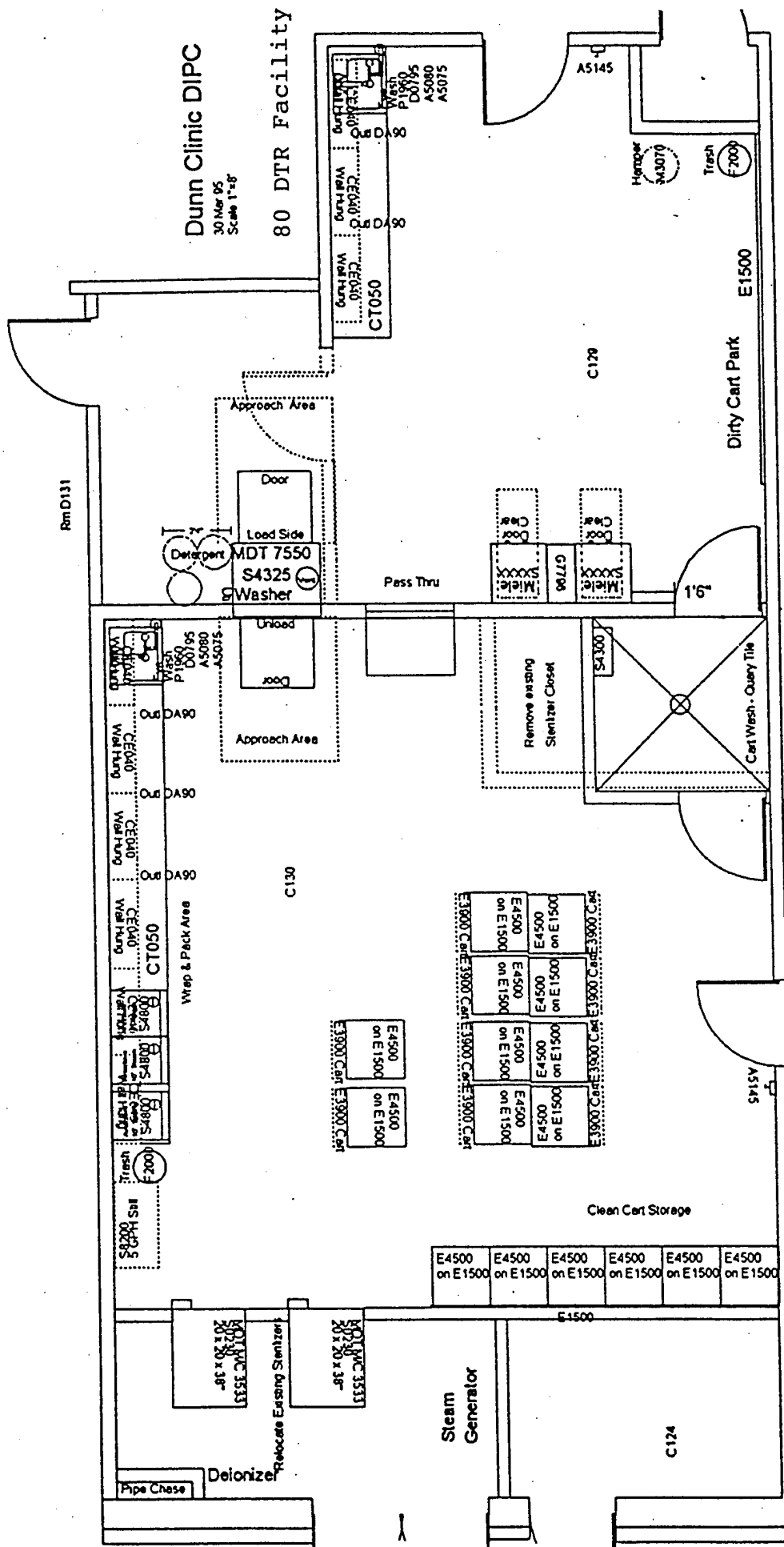

Figure 5a: Large Dental Instrument Processing Center Floor Plan

Floor Plan for Proposed DIPC in Dental Clinic

Wright-Patterson AFB, OH

Scale" 1/4"=1'-0"



FLOOR PLAN Scale: 3/16" = 1'-0"

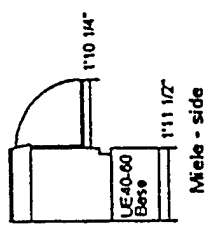
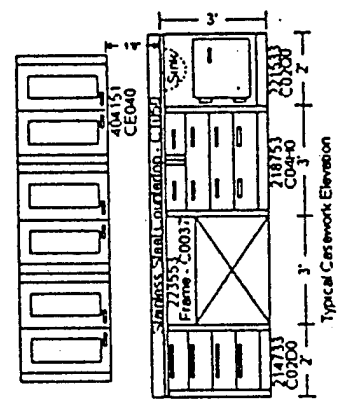
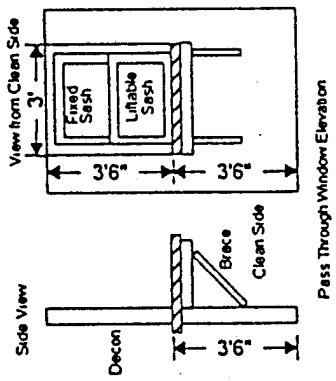

G7781	S4000X	JE40-60	Base	Male Elevation
G7781	S4000X	JE40-60	Base	

Figure 5b: Large Dental Instrument Processing Center Floor Plan

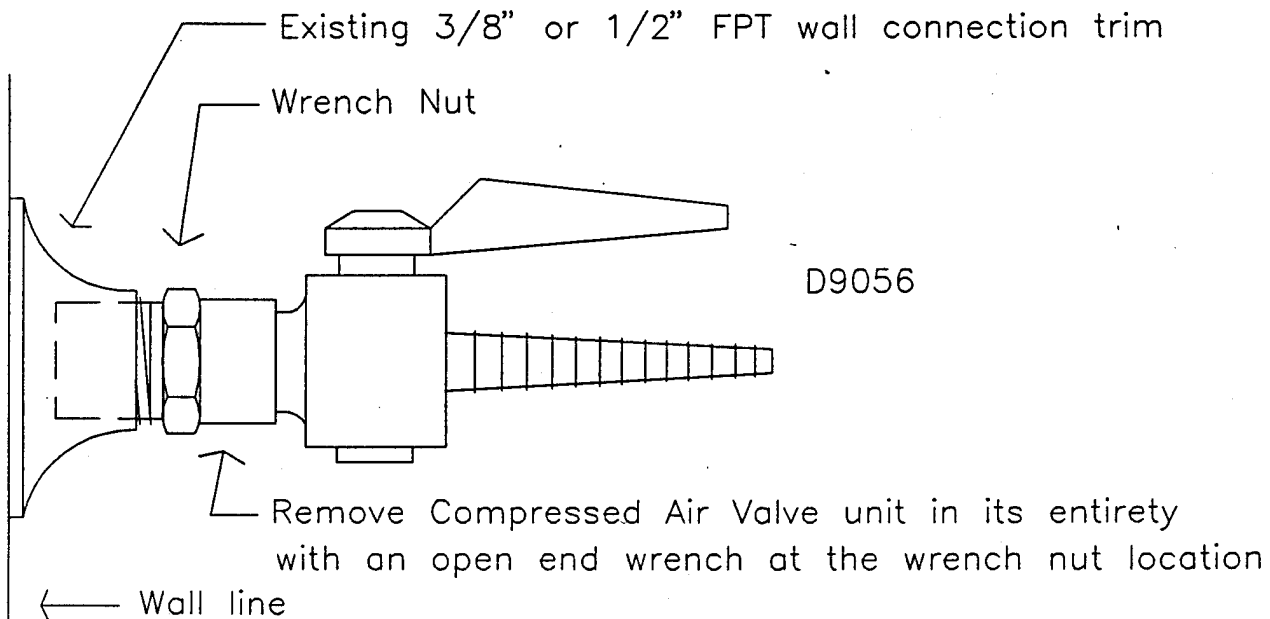

Original Needle Valve

Scale: full size

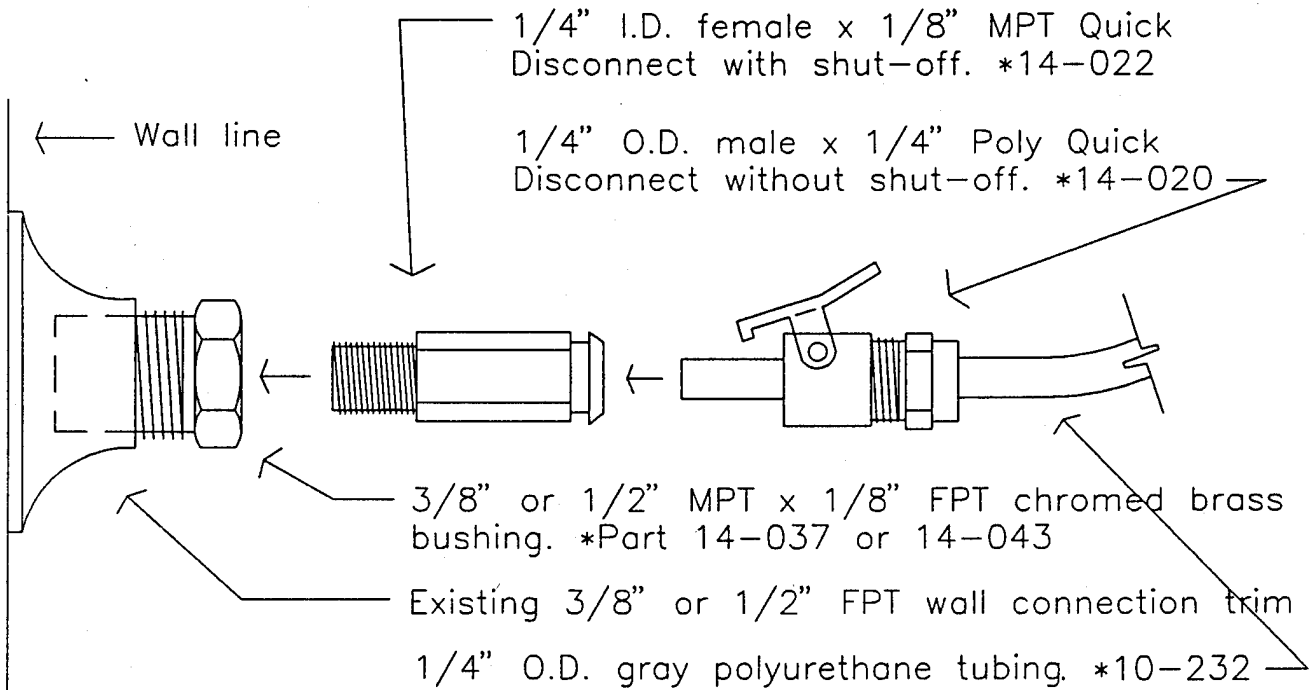

Recommended 90 PSI Air Connection at Existing Air Outlets in Sterilization Areas

Scale: Full Size

*Numbers shown are part numbers as manufactured and supplied by Chapman-Huffman Company, 320 S.E. Bridgeford Blvd., Suite 1, Bend, Oregon 97702, Ph. (541) 382-7869

Figure 6a : Recommended 90 PSI Air Connection at Existing Air Outlets in Sterilization Areas

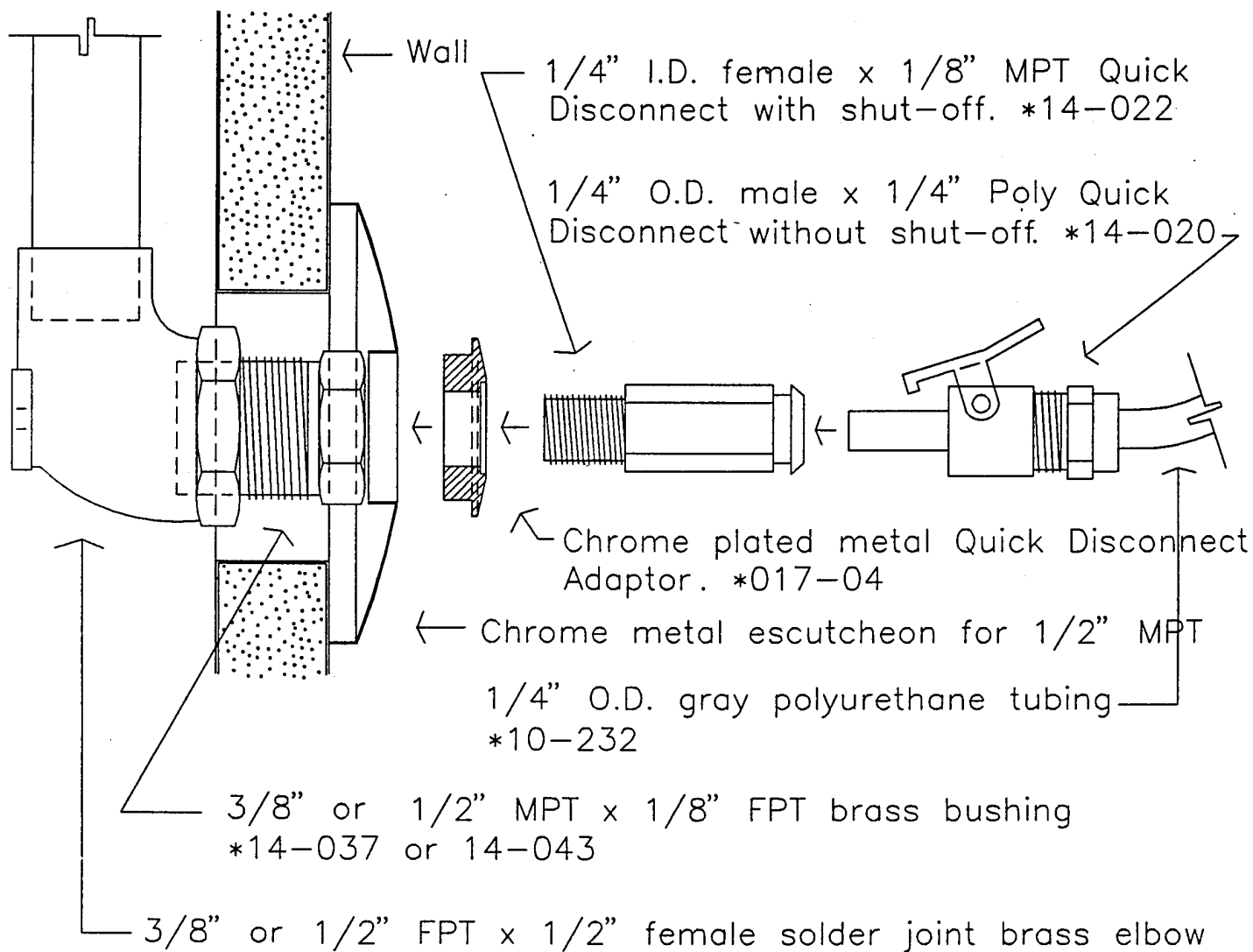

*Numbers shown are part numbers as manufactured and supplied by Chapman-Huffman Company, 320 S.E. Bridgford Blvd., Suite 1, Bend, Oregon 97702, Ph. (541) 382-7869

Recommended 90 PSI Air Connection at New Air Outlets in Sterilization areas

Scale: full size

Figure 6b: Recommended 90 PSI Air Connection at new Air Outlets in Sterilization Areas

10. References

Air Force Pamphlet (AFP) 160-9, Medical Service Central Supply Service, 6 March 1992.

29 CFR 1910.1030, December 1991 (Bloodborne Pathogens Standard).

Dental Items of Significance #37, "USAF Dental Service Infection Control Program," USAF Dental Investigation Service, June 1992.

"Good Hospital Practice: Handling and Biological Decontamination of Reusable Medical Devices," Association for the Advancement of Medical Instrumentation Standard #35, 1991.

Joint Commission on the Accreditation of Healthcare Organizations Standards, 1993.

MIL-C-20709D, latest edition, Military specification, Casework, Metal and wood (Medical and Dental).

MIL- HDBK-1191, 15 October 1991, Department of Defense Medical Military Construction Program Facilities Design and Construction Criteria.

Military Standard 1691E (MIL-STD-1691E), 8 October 1991, Defense Medical Facilities Office, Master Medical Equipment List.

National Fire Protection Association (NFPA) Standard No.99, May 1993.

"Recommended Infection Control-Practices for Dentistry, 1993," U.S. Department of Health and Human Services, Centers for Disease Control, May, 1993.

"Steam Sterilization and Sterility Assurance in Office-based, Ambulatory-care Medical and Dental Facilities," Association for the Advancement of Medical Instrumentation Standard #42, 1992.

Appendix A

Step - by - Step Guide for Designing a Dental Instrument Processing Center in a New or Existing Facility

1. Select a cassette system

2. Estimate the number of cassettes generated per day:

2.1 Simple estimate: 10 x the number of DTRs in operation on average per day including prophylaxis, sick call, exam, etc.

2.2 Better estimate - This estimate takes into account the varying size of some loads. For example, four small loads probably take up about as much space in a sterilizer as one full size cassette whereas a Mayo size surgery pack probably takes up four times as much space as a cassette.

Small loads per day

(1-5 instruments not in a cassette)/4 = _____

Half size cassettes produced per day /2 = _____

Full size cassettes produced per day = _____

Surgery packs not in cassettes

(approx: 19.5" x 13" x 2.5") * 4 = _____

Total full cassette equivalents per day = _____

3. Take the dimensions of your cassette system and the number of cassettes per day you estimate producing per day in the previous step and contact several equipment makers to get an estimate of the size instrument washer and sterilizer you need. The answer will vary depending on the size of your cassettes and the rack dimensions in an individual sterilizer or washer. Assuming 10-20 minutes required to load and unload equipment and running the equipment 8 hours a day some ball park estimates are:

*** These estimates will vary depending on varying clinic workloads, cassette sizes, equipment and rack capacities. Please consult with equipment manufacturers on an individual basis before considering purchase. Use these estimates as a starting point only. ***

3.1 Washers:

3.1.1 Dishwasher size thermoisinfectant: 20 Cassettes per hour or 160 cassettes per day. One of these units can service a 12-18 DTR clinic.

3.1.2 22" medical style washers: 18 cassettes per half hour or 288 cassettes per day or more depending on the shelf configuration. Suitable for a 18-35 DTR clinic.

3.1.3 26" medical style washers: 25 cassettes per half hour or 400 cassettes per day. Suitable for a 35-50 DTR clinic.

3.2 Sterilizers:

3.2.1 Table top 10" - 15" gravity sterilizers: < 10 DTRs

3.2.2 16" Pre vacuum sterilizers - up to 16 DTRs

3.2.3 20" Pre vacuum sterilizers - up to 35 DTRs

3.2.4 24" Pre Vacuum sterilizers - over 35 DTRs

4. Find a soft water source for the equipment - Consult with your plant manager, and base civil engineers. Soft water will prolong the equipment life greatly. Adding a water softener to the project may be necessary.

5. Decide how will your sterilizer and washer be powered: piped steam or electricity? Will a separate steam generator be required?

6. Make an estimate of the heat that will be generated in BTU/Hr. Consult with your base civil engineer on the best way to get sufficient air flow and cooling. Is it possible to get a separate air handling zone for the clean side? This may influence the room you choose for your dental instrument processing center. Once final equipment selection is made, a mechanical engineer can determine the heat generated from the equipment characteristics.

7. Estimate the space needed for the dental instrument processing center:

$$140 + 11 \times (\text{No of DTRs}) = \text{Net Square Feet Needed}$$

8. Consider how instruments will be brought to the dental instrument processing center. Consider where the arriving instruments will be stored before they are processed. Next consider where sterile instruments will be stored and how they will be redistributed to the DTRs. Some type of mobile cart system may be considered.

9. Using all the above information select the best location for your dental instrument processing center that will satisfy the most of the above considerations. If DTRs need to be disestablished, obtain approval through your command surgeon and HQ USAF/SGD.

10. Is the lighting adequate in the chosen location? Is the ceiling, walls, and flooring water resistant? Is 90 PSIG air available for handpiece purging? If not, consider these things in your construction project.

11. Locate plans/blue prints showing the floor plan, plumbing, and heating, ventilation and Air Conditioning (HVAC) (air handling system) for the location you have chosen. If plans are photocopied be sure they are reduced exactly 50% so the scale is not altered. A sketch showing where equipment is currently located as well as a list and technical data for equipment to be used is very helpful to the designers. Consult with Base Civil Engineering (CE), DIS, and your USAF Regional Health Facilities Office to help develop a layout for your project. Please send all the information above along with your plans and provide a point of contact at your facility.

12. All construction projects should be approved by your command surgeon and HQ USAF/SGD as well as reviewed by DIS. Once plans have been developed and approvals obtained, complete AF Form 332 to request base CE begin construction. Health facilities offices (HFOs), and DIS can both help in developing a scope of work and other required documents as the project proceeds. Both DIS and your HFO should be kept informed and be placed on the submittal list to review your design as the project proceeds. Both the HFO's and DIS are provided to you by the USAF Surgeon General to help you obtain the best design value for your facility in terms of medical function for DIPC or any other facilities modification. DIS can supply you with the address and telephone number for your regional HFO.

13. Appendix B contains a DIPC Check List to be filled out by USAF dental clinics requiring either a new DIPC or the modification of an existing one. The information should be provided to DIS so that we can custom design your DIPC project.

Appendix B

DIPC Information Check List

1. Identification

Address: _____

Base: _____

POC: _____

Phone(DSN) or Commercial: _____

Fax(DSN) or Commercial: _____

2. Workload Data

Peak Number of DTRS in Operation: _____

(Includes Doctors, Propy, Sick Call, Exam, etc)

Brand Cassette and Size Selected: _____

3. Existing equipment items

Sterilizers: Types, name brands, catalog data, and sizes: _____

Washers: Types, name brands, catalog data, and sizes: _____

Distillers, deionizers, other: _____

4. Where will the DIPC be located?

Room numbers: _____

Room(s) size(s): _____

Ceiling Height: _____

Net Square Feet(NSF): _____

Desired NSF = $140SF + (DTRs \times 11SF) =$ _____

5. Water quality

Does your clinic have an operational water softener and piped soft water? _____

If so, is piped soft cold water available? _____

Is piped soft hot water available? _____

What is the total hardness of your water? _____

(Typical units or grains per gallon or mg/L)

(Total hardness = mg/L of $CaCO_3$ + mg/L of $MgCO_3$)

(Bonus Fun Fact: Grains/Gallon x 17.12 = Mg/L)

6. Distilled Water

Do you already have a source of distilled water for table top autoclaves? _____
Should a distiller to produce distilled water be included in this project? _____

7. Sterilizer/Washer Power Source

Is piped steam at 50-80 PSI available in your facility? _____
If so, Is it 97% condensate free (dry steam)? _____
Are amines, hydrazine or other boiler chemicals used in the boiler that makes the steam?
(Very important)? _____

8. Electrical

How many cycles per second or hertz (Hz) is your electricity? 60Hz or 50Hz? _____
Is 3-phase power available? _____
What are the voltages/phases available? 208V/115V, 3-phase; 240V/120V, 1-phase;
480V/227V, 3-phase?

9. Carts

How will instruments be transported to and from the dental instrument processing center
(DIPC)? _____

Single Loop? (Dirty carts brought in are cleaned in a steam wash): _____
Double Loop? (Separate clean and dirty carts - requires two trips to DIPC, one to drop off
dirty stuff & return the cart then a second trip to pick up clean stuff & return the cart to the
DIPC): _____

10. Complete set of drawings prints to include at minimum:

Architectural Floor Plan(s), Reflected Ceiling Plan(s), Room Finish Schedule(s), Wall
Sections, Roof Plan, Legends, Equipment Schedules, Mech (Plumbing, Electrical, HVAC)
Floor Plans (above ceilings and below floors)

USAF Dental Investigation Service
AL/AOCD, Fax: 240-2691(DSN), 210-536-2691 (Commercial)
2507 Kennedy Circle Phone: 240-3502(DSN), 210-536-3502(Commercial)
Bldg 125, Room 215
Brooks AFB TX 78235-5118

Companies to Collect Information From:

1. Carts

Milcare: 800-525-0586, 210-226-6661
Healthmart: 800-521-6224, 313-774-7600

2. Metal cabinets and countertop

St Charles Industries: 708-584-3800

3. Washers

Miele: 800-843-7231, 908-560-0899
Info on G7781 washer, E131 racks& baskets, G7796 Soap Dispenser, UE40-60 Base,
G7736 Washer

4. Washers and Sterilizers:

MDT: 800-394-4638, 410-757-8585 (7550 washer for large clinics, Pre-Vac Sterilizers)

Amsco: 800-333-8848, 814-870-8165 (444 Washer for large clinics, Pre-vac Sterilizers)

5. Eyewashes and General Safety Products

Lab Safety: 800-356-0783, 608-754-7160 Great catalog and tech support

6. Distillers/water softeners/deionizers

Culligan - local dealer, lease softners, Deionizers, No distillers
Barnstead - Distillers on GSA Contract - 800-446-6060 (Ask for Water Book Catalog)(Will
measure the hardness of your water for free)
Millipore - Reverse Osmosis, distiller alternatives - 800-225-1380

7. Cassettes: See Synopsis in DIS 41 (Jan 94) for complete list

CT Med: 317-543-4250
IMS: 312-975-6100
Aesculap: 415-876-7000