

rec'd
6/14/71

NASA TECHNICAL NOTE

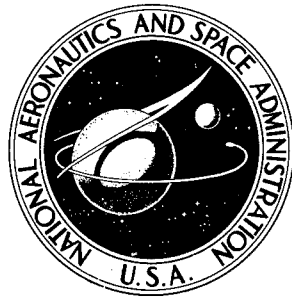

NASA TN D-6353

NASA TN D-6353

DTIC QUALITY INSPECTED 2

FRICITION AND WEAR OF
POLY (AMIDE-IMIDE), POLYIMIDE,
AND PYRRONE POLYMERS
AT 260° C (500° F) IN DRY AIR

by William R. Jones, Jr., William F. Hady,
and Robert L. Johnson

Lewis Research Center
Cleveland, Ohio 44135

19960314 025

PLASTEC

14765

NATIONAL AERONAUTICS AND SPACE ADMINISTRATION • WASHINGTON, D. C.

MAY 1971

DISTRIBUTION STATEMENT A
Approved for public release;
Distribution Unlimited

1. Report No. NASA TN D-6353		2. Government Accession No.		3. Recipient's Catalog No.	
4. Title and Subtitle FRICION AND WEAR OF POLY(AMIDE-IMIDE), POLYIMIDE, AND PYRRONE POLYMERS AT 260⁰ C (500⁰ F) IN DRY AIR				5. Report Date May 1971	
				6. Performing Organization Code	
7. Author(s) William R. Jones, Jr., William F. Hady, and Robert L. Johnson				8. Performing Organization Report No. E-6096	
9. Performing Organization Name and Address Lewis Research Center National Aeronautics and Space Administration Cleveland, Ohio 44135				10. Work Unit No. 126-15	
				11. Contract or Grant No.	
12. Sponsoring Agency Name and Address National Aeronautics and Space Administration Washington, D. C. 20546				13. Type of Report and Period Covered Technical Note	
				14. Sponsoring Agency Code	
15. Supplementary Notes					
16. Abstract <p>A pin-on-disk sliding friction apparatus was used to determine the friction and wear of (1) a poly(amide-imide), (2) a polyimide, and (3) a pyrrone in dry air at 260⁰ C (500⁰ F). Low wear was obtained with a pyrrone, intermediate wear with a polyimide, and very high wear with a poly(amide-imide). All three polymers exhibited low (<0.20) coefficients of friction. The poly(amide-imide) exhibited thermal degradation at 260⁰ C (500⁰ F). Experiments were conducted using a hemispherically tipped rider (pure polymer) sliding on a rotating steel disk. Other conditions included a sliding speed of 10 m/min (390 in./min), a 1.5-kg load, and a mineral oil lubricant.</p>					
17. Key Words (Suggested by Author(s)) Seals Pyrrone Polymers Polyimide Boundary lubrication Poly(amide-imide)				18. Distribution Statement Unclassified - unlimited	
19. Security Classif. (of this report) Unclassified		20. Security Classif. (of this page) Unclassified		21. No. of Pages 17	22. Price* \$3.00

FRICION AND WEAR OF POLY(AMIDE-IMIDE), POLYIMIDE, AND PYRRONE POLYMERS AT 260° C (500° F) IN DRY AIR

by William R. Jones, Jr., William F. Hady, and Robert L. Johnson

Lewis Research Center

SUMMARY

A pin-on-disk sliding friction apparatus was used to determine the friction and wear of three pure (unfilled) polymers in dry air at 260° C (500° F). The polymers were (1) a poly(amide-imide), (2) a polyimide, and (3) a pyrrone.

Low wear was obtained with a pyrrone, intermediate wear with a polyimide, and very high wear with a poly(amide-imide) under lubricated conditions at 260° C (500° F) in dry air. All three polymers exhibited low coefficients of friction (typical <0.20) under these conditions. The poly(amide-imide) exhibited thermal degradation at 260° C (500° F). All three unlubricated polymers exhibited high wear and high coefficients of friction at 260° and 23° C (500° and 73° F) in dry air.

Experiments were conducted using a 0.476-centimeter- (0.187-in. -) radius hemispherically tipped rider (polymer) sliding on a rotating disk (M-50 steel). Experimental conditions, in most cases, were a sliding speed of 10 meters per minute (390 in./min), a 1.5-kilogram load, a 260° C (500° F) disk temperature, a test duration of 25 minutes, and a superrefined paraffinic mineral oil lubricant.

INTRODUCTION

Supersonic flight speeds have created many high temperature related lubrication and sealing problems. One of these problems involves fluid sealing in hydraulic actuators. Recently, work has been reported on the development of high temperature (260° C or 500° F) rod seals using a polyimide material (refs. 1 to 4).

The polyimides are a member of the new class of high temperature aromatic-heterocyclic polymers that have been developed during the last few years. The polyimides, which are condensation polymers formed from the reaction of pyromellitic dianhydrides and aromatic diamines, possess many properties needed for high temperature

seals. These include good thermal stability, fluid compatibility, low friction and wear, and retention of mechanical properties at high temperatures (refs. 3 and 5).

Another polymer which has found use in many high temperature applications is a combination of nylon and polyimide, commonly called poly(amide-imide). This polymer, which is based on trimellitic anhydride, has good thermal stability and good mechanical properties. A more recent addition to this class of high temperature polymers are the polyimidazopyrrolones (commonly called pyrrones). These polymers may possess even higher thermal stability and better mechanical properties than the polyimide class of polymers (ref. 6). Pyrrones are prepared by the condensation of aromatic tetraacids or dianhydrides with aromatic tetraamines. They possess excellent oxidation stability, thermal stability, and mechanical properties (ref. 7). The preparation problem of pyrrones (excessive release of volatiles during cure) has now been overcome by a simultaneous polymerization and molding process (refs. 8 and 9).

Table I compares a number of typical properties for polyimide, poly(amide-imide), and pyrrone. Figure 1 illustrates their chemical structures. All polymers are step-ladder in overall structure. The pyrrone used in this study is the oligomer formed by the condensation of 3,3'-4,4' benzophenone tetracarboxylic acid dianhydride and 3,3'-4,4' tetraaminobiphenyl. Details of the synthesis and molding process are described in reference 7.

The objective of this investigation was to determine the friction and wear of a polyimide, a poly(amide-imide), and a pyrrone. Hemispherically tipped riders of the pure (unfilled) polymers were run in sliding contact with a rotating M-50 steel disk in dry air. Other conditions were a sliding speed of 10 meters per minute (390 in./min), a 1.5-kilogram load, and a test duration of 25 minutes. The lubricant was a superrefined paraffinic mineral oil.

APPARATUS

The friction and wear test apparatus is shown in figure 2. The test specimens were contained inside a stainless-steel chamber.

Specimens

A 6.3-centimeter- (2.5-in. -) diameter disk (M-50 steel) is placed in sliding contact with a 0.476-centimeter- (0.187-in. -) radius hemispherically tipped polymer rider. A normal load of 1.5 kilograms was applied with a deadweight. Disks were made of M-50 steel with a hardness of 62 to 64 Rockwell C. Riders were made of either poly(amide-imide), polyimide, or pyrrone with hardnesses of 81, 60, and 93 Rockwell E, respectively. All specimens were pure polymer (unfilled).

The disk was partially submerged in a pyrex cup containing the test lubricant. The disk was heated by induction. Bulk lubricant temperature was recorded with a thermocouple. Disk temperature was monitored with an infrared pyrometer. Frictional force was measured with a strain gage and recorded.

Atmosphere

The test atmosphere was dry air (<500 ppm H₂O). Dry air was obtained by drying and filtering service air. Moisture content was monitored by a moisture analyzer with an accuracy of ±10 parts per million.

PROCEDURE

Specimen Preparation

Disks were made of M-50 steel. They were ground and lapped to a surface finish of 10×10^{-8} to 20×10^{-8} meter (4 to 8 μ in. rms). Disks were scrubbed with a paste of levigated alumina and water, rinsed with tap water and distilled water, then placed in a dessicator.

Riders were made of each test polymer and cleaned with 100 percent ethyl alcohol. A nondegassed superrefined paraffinic mineral oil was used as the lubricant. Some typical properties of this lubricant supplied by the manufacturer are as follows:

Specific gravity at 16° C (60° F)	0.846
Flash point, COC, °C (°F)	199 (390)
Fire point, COC, °C (°F)	219 (426)
Pour point, °C (°F)	-57 (-70)
Thermal decomposition (isoteniscope), °C (°F)	357 (675)
Kinematic viscosity in m ² /sec (cS) at	
288° C (550° F)	5.6×10^{-7} (0.56)
99° C (210° F)	3.32×10^{-6} (3.32)
38° C (100° F)	1.541×10^{-5} (15.41)
-18° C (0° F)	3.75×10^{-4} (375)

Test Procedure

The specimens were assembled and 7×10^{-5} cubic meter (70 ml) of lubricant were

placed in the lubricant cup. The test chamber ($3.7 \times 10^{-3} \text{ m}^3$ or 3.7 liter volume) was purged with dry air for 10 minutes at a flow rate in excess of 6×10^{-2} cubic meter per hour (50 liters/hr). The disk was heated to 260° C (500° F) while rotating, and the rider was loaded against the disk with a deadweight. Dry air flow rate was reduced to 3.5×10^{-2} cubic meter per hour (35 liters/hr) and a $6.9 \times 10^3 \text{ N/cm}^2$ (1 psig) pressure was maintained in the chamber. The lubricant was heated only by heat transfer from the disk. Therefore, the bulk lubricant temperature (measured with a thermocouple) gradually increased during the test to 150° to 180° C (300° to 360° F).

Frictional force and bulk lubricant temperature were continuously recorded. Disk temperature was continuously monitored. Tests were terminated at 25 minutes, and rider wear scar diameter was recorded. Disk temperature calibration is described in detail in reference 10.

RESULTS AND DISCUSSION

Rider Wear Volume

Rider wear volumes for the three polymers in dry air at 260° and 23° C (500° and 73° F) appear in figure 3 and table II.

In order to facilitate discussion of rider wear, four arbitrary wear levels were defined. These levels are (1) low wear which corresponds to a wear rate of less than 1.7×10^{-14} cubic meter per minute ($10^{-9} \text{ in.}^3/\text{min}$), (2) intermediate wear (wear rate between 1.7×10^{-14} and $1.7 \times 10^{-13} \text{ m}^3/\text{min}$ or 10^{-9} and $10^{-8} \text{ in.}^3/\text{min}$), (3) high wear (wear rate between 1.7×10^{-13} and $1.7 \times 10^{-12} \text{ m}^3/\text{min}$ or 10^{-8} and $10^{-7} \text{ in.}^3/\text{min}$), and (4) very high wear (wear rate greater than $1.7 \times 10^{-12} \text{ m}^3/\text{min}$ or $10^{-7} \text{ in.}^3/\text{min}$).

Lubricated at 260° C (500° F)

As shown in figure 3, low wear was obtained with a pyrrone, intermediate wear with a polyimide, and very high wear with a poly(amide-imide) lubricated with a mineral oil at 260° C (500° F).

Typical rider wear scars for the three polymers lubricated with the mineral oil at 260° C (500° F) appear in figure 4. Lubricant degradation products and wear debris are noted in the inlet region of the contact for all three polymers. A very poorly defined contact area is noted for the pyrrone rider in figure 4(c).

Figure 5 shows another pyrrone contact area before and after scrubbing with alcohol. After scrubbing with alcohol (fig. 5(b)), no wear scar is evident. In fact, machining

marks can still be seen. This phenomenon was observed with the pyrrone in all the lubricated tests at 260° C (500° F). A wear value of less than 10^{-14} cubic meter per minute (6×10^{-10} in.³/min) is recorded for the pyrrone. This corresponds to a wear scar of less than 0.4 millimeter, which indicates negligible wear.

Unlubricated at 260° and 23° C (500° and 74° F)

A few tests were performed without a lubricant at 260° C (500° F) and at room temperature, 23° C (73° F). The wear results also appear in figure 3 and table II.

At 260° C (500° F) very high wear was obtained with the poly(amide-imide) and high wear with the polyimide and the pyrrone. High wear was observed for all three polymers at 23° C (73° F).

Poly(amide-imide) Degradation

There was considerable wear variation with the poly(amide-imide) lubricated with the mineral oil at 260° C (500° F). Also apparent in many of the tests was severe thermal degradation. Cracking, plastic deformation, and discoloration was evident to varying degrees. Figure 6 illustrates the degrees of the thermal degradation. Apparently 260° C (500° F) is just beyond the maximum usable temperature for a sliding application with this polymer.

Coefficient of Friction

Coefficients of friction for the three polymers at 260° and 23° C (500° and 73° F) appear in figure 7 and table III.

All three polymers lubricated with the mineral oil at 260° C (500° F) exhibited low (<0.20) typical coefficients of friction. At 260° C (500° F) the typical coefficients of friction for the unlubricated poly(amide-imide), polyimide, and pyrrone were 0.43, 0.30, and 0.74, respectively. At 23° C (73° F) all three unlubricated polymers exhibited typical coefficients of friction greater than 0.60.

The following concluding remarks are made:

- (1) The poly(amide-imide) is not suitable for use in sliding friction applications at 260° C (500° F) in air.
- (2) The pyrrone is suitable (under lubricated conditions) for sliding friction applications at 260° C (500° F) in air and appears to be superior to polyimide.

SUMMARY OF RESULTS

A pin-on-disk sliding friction apparatus was used to determine the friction and wear of three pure (unfilled) polymers at 260^o C (500^o F) in dry air. The polymers were evaluated both dry and lubricated with a superrefined mineral oil. Other conditions included a sliding speed of 10 meters per minute (390 in./min) and a 1.5-kilogram load. The following results were obtained:

1. Low wear was obtained with a pyrrone, intermediate wear with a polyimide, and very high wear with a poly(amide-imide) lubricated at 260^o C (500^o F) in dry air.
2. All three polymers exhibited low coefficients of friction (typical <0.20) when lubricated at 260^o C (500^o F) in dry air.
3. The poly(amide-imide) exhibited thermal degradation at 260^o C (500^o F) in dry air.
4. All three unlubricated polymers exhibited high wear and high coefficients of friction at 260^o and 23^o C (500^o and 73^o F) in dry air.

Lewis Research Center,
National Aeronautics and Space Administration,
Cleveland, Ohio, March 1, 1971,
126-15.

REFERENCES

1. Lee, J.: Development of High Temperature Polyimide Rod Seals. Rep. FHR 3612-1, Fairchild Hiller Corp. (NASA CR-72563), Aug. 21, 1969.
2. Loomis, William R.; Johnson, Robert L.; and Lee, John: High-Temperature Polyimide Hydraulic Actuator Rod Seals for Advanced Aircraft. Presented at the SAE National Aeronautic and Space Engineering and Manufacturing Meeting, Los Angeles, Calif., Oct. 5-8, 1970.
3. Lee, J.: High-Temperature Hydraulic System Actuator Seals for Use in Advanced Supersonic Aircraft. Rep. 2704-4, Fairchild Hiller Corp. (NASA CR-72354), Sept. 15, 1967.
4. Lee, J.: High-Temperature and Fluid-Resistant Seal and Sealant Materials for the Supersonic Transport. Republic Aviation Corp. (ML-TDR-64-266, AD-454519), Sept. 1964.
5. Anon.: New Fibers For High-Temperature Heights. Chemical Eng., vol. 73, no. 4, Feb. 14, 1966, pp. 90-92.

6. Tessler, Martin M.: Theoretical Studies on Thermal Degradation of Ladder Polymers. Rep. ML-TDR-64-151, pt. 2, Air Force Systems Command, Dec. 1965. (Available from DDC as AD-629740.)
7. Hughes, C. T.: Preparation and Characterization of Low DP End-Capped Pyrrone Moldings. NASA CR-1633, 1970.
8. Morgan, P. E. D.; and Scott, H.: Strong, Dense, Thermally Stable Polymers by Reactive Hot Pressing of Solid Organic Monomers. Polymer Letters, vol. 7, 1969, pp. 437-442.
9. Morgan, P. E. D.; and Scott, H.: Simultaneous Polymerization and Molding of Pyrrone Polymers. NASA CR-1737, 1971.
10. Jones, William R., Jr.; and Hady, William F.: Effect of Humidity and a Wettability Additive on Polyphenyl Ether Boundary Lubrication of Steel in Air and Nitrogen to 350^o C. NASA TN D-6055, 1970.

TABLE I. - SUMMARY OF TYPICAL PROPERTIES FOR THREE MOLDED POLYMERS^a

Property	Pyrrone	Poly(amide-imide)	Polyimide
Tensile strength at 23° C (73° F), N/m ² (psi)	7.37×10 ⁷ (10 700)	9.16×10 ⁷ (13 300)	7.23×10 ⁷ (10 500)
Elongation to fracture at 23° C (73° F), percent	~1	2.0 to 2.5	5 to 6
Flexural modulus at 23° C (73° F), N/m ² (psi)	9.0×10 ⁹ (13×10 ⁵)	4.8×10 ⁹ (7×10 ⁵)	3.2×10 ⁹ (4.6×10 ⁵)
Flexural strength at 23° C (73° F), N/m ² (psi)	12×10 ⁷ (17 500)	16×10 ⁷ (23 400)	9.6×10 ⁷ (14 000)
Shear strength at 23° C (73° F), N/m ² (psi)	(b)	13×10 ⁷ (18 800)	8.2×10 ⁷ (11 900)
Compressive strength at 23° C (73° F), N/m ² (psi)	16.2×10 ⁷ (23 500)	24.3×10 ⁷ (>35 300)	>16.5×10 ⁷ (>24 000)
Impact strength (IZOD) at 23° C (73° F), J/m	(b)	0.7	0.9
Coefficient of thermal expansion (23° to 204° C or 73° to 95° F), m/m/°C (in. /in. /°F)	4.9×10 ⁻⁵ (2.7×10 ⁻⁵)	3.4×10 ⁻⁵ to 4.0×10 ⁻⁵ (1.9×10 ⁻⁵ to 2.2×10 ⁻⁵)	4.7×10 ⁻⁵ to 5.4×10 ⁻⁵ (2.6×10 ⁻⁵ to 3.0×10 ⁻⁵)
Thermal conductivity, J/(m)(sec)(K)	(b)	7.6	18 to 23
Dielectric strength short time at 23° C (73° F), V/mil	2500	440	560
Volume resistivity at 23° C (73° F), Ω/cm	10 ¹⁶	0.8×10 ¹⁵	10 ¹⁶ _i to 10 ¹⁷
Dielectric constant (10 ⁵ Hz) at 23° C (73° F)	(b)	3.8 to 4.1	3.4
Hardness ^c (0.00635-cm- or 1/4- in.-diam. specimens), Rockwell E	93	81	60
Specific gravity	1.3	1.41	1.43
Thermal stability in air, °C (°F)	^d 400 (752)	^e 288 (550)	^e 260 (500)
Thermal stability in nitrogen, °C (°F)	^d 600 (1112)	-----	^e 316 (601)

^aManufacturer's data except where noted.

^bNot available.

^cMeasured by authors.

^dThermogravimetric analysis, 0.5° C/min (0.9° F/min).

^eMaximum recommended continuous operating temperature.

TABLE II. - AVERAGE RIDER WEAR VOLUME FOR THREE POLYMERS IN DRY AIR

[Sliding speed, 10 m/min (390 in./min); load, 1.5 kg; test duration, 25 min.]

Conditions	Average rider wear volume, m ³ /min (in. ³ /min)	Number of tests	Average rider wear volume, m ³ /min (in. ³ /min)	Number of tests	Average rider wear volume, m ³ /min (in. ³ /min)	Number of tests
	Poly(amide-imide)		Polyimide		Pyrrone	
Lubricated with superrefined mineral oil at 260° C (500° F)	390×10 ⁻¹⁴ (2.4×10 ⁻⁷)	8	10×10 ⁻¹⁴ (6.1×10 ⁻⁹)	8	<1×10 ⁻¹⁴ (<6.1×10 ⁻¹⁰)	5
Unlubricated 260° C (500° F)	1360×10 ⁻¹⁴ (8.3×10 ⁻⁷)	2	92×10 ⁻¹⁴ (5.6×10 ⁻⁸)	2	190×10 ⁻¹⁴ (1.2×10 ⁻⁷)	2
Unlubricated 23° C (73° F)	50×10 ⁻¹⁴ (3.0×10 ⁻⁸)	1	42×10 ⁻¹⁴ (2.6×10 ⁻⁸)	1	42×10 ⁻¹⁴ (2.6×10 ⁻⁸)	1

TABLE III. - TYPICAL COEFFICIENT OF FRICTION FOR THREE POLYMERS IN DRY AIR

[Sliding speed, 10 m/min (390 in./min); load, 1.5 kg; test duration, 25 min.]

Conditions	Typical coefficient of friction	Range of coefficient of friction (minimum to maximum)	Typical coefficient of friction	Range of coefficient of friction (minimum to maximum)	Typical coefficient of friction	Range of coefficient of friction (minimum to maximum)
	Poly(amide-imide)		Polyimide		Pyrrone	
Lubricated with superrefined mineral oil at 260° C (500° F)	0.16	0.11 to 0.33	0.13	0.07 to 0.23	0.16	0.12 to 0.20
Unlubricated 260° C (500° F)	.43	.20 to .65	.30	.15 to .60	.74	.63 to .87
Unlubricated 23° C (73° F)	.62	.30 to .73	.73	.33 to .80	.66	.63 to .68

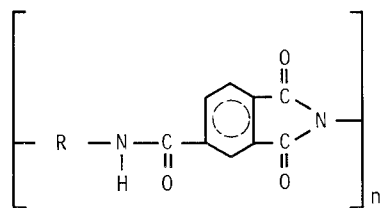

(a) Poly(amide-imide).

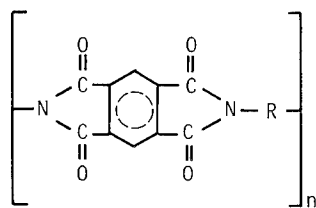

(b) Polyimide.

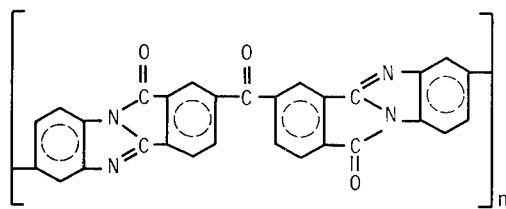

(c) Pyrrone.

Figure 1. - Chemical structures for poly(amide-imide), polyimide, and pyrrone.

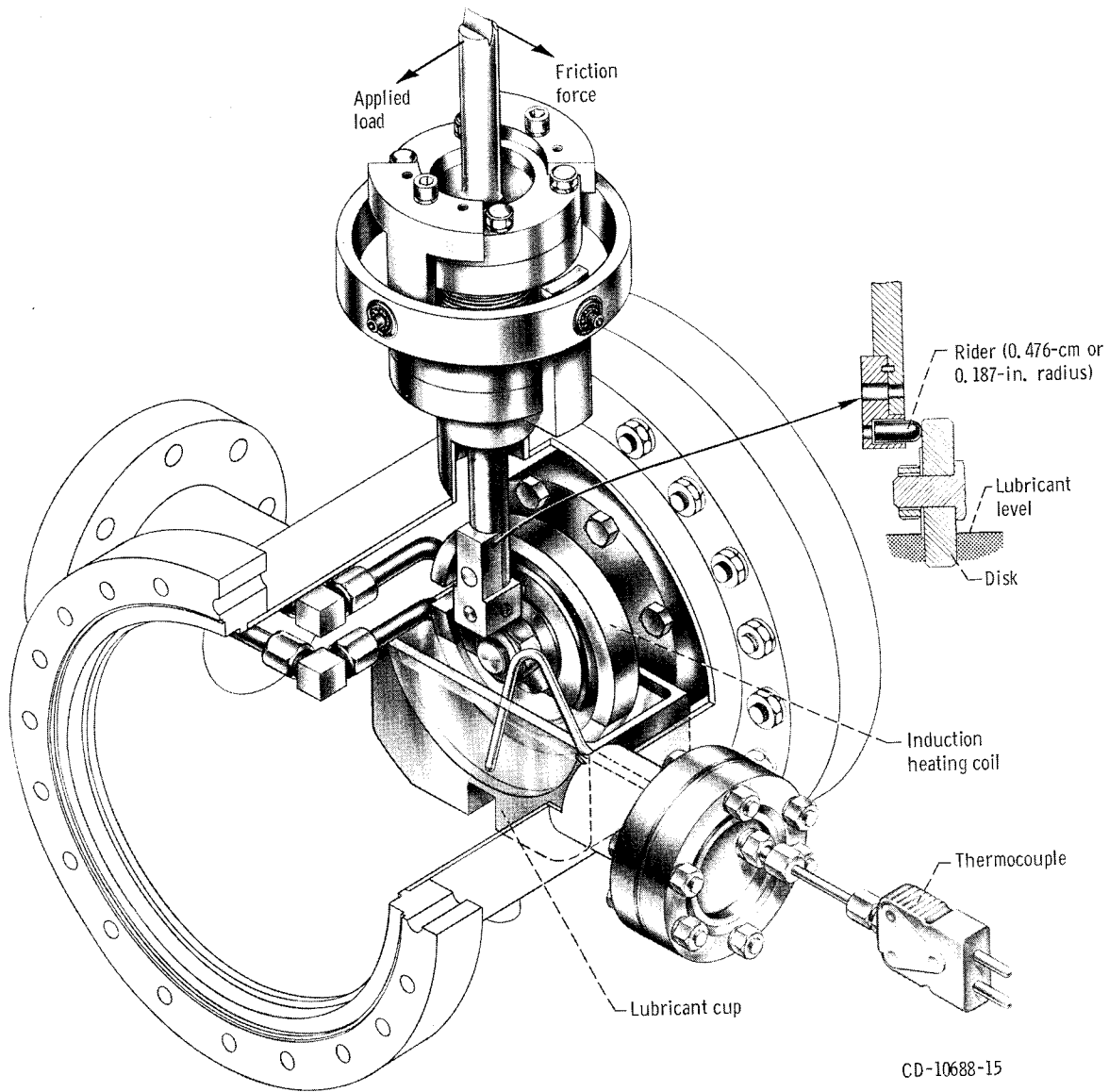

Figure 2. - Friction and wear apparatus.

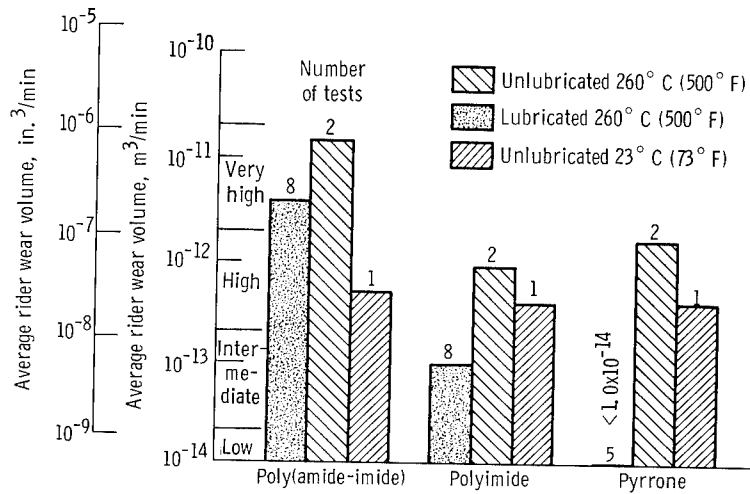
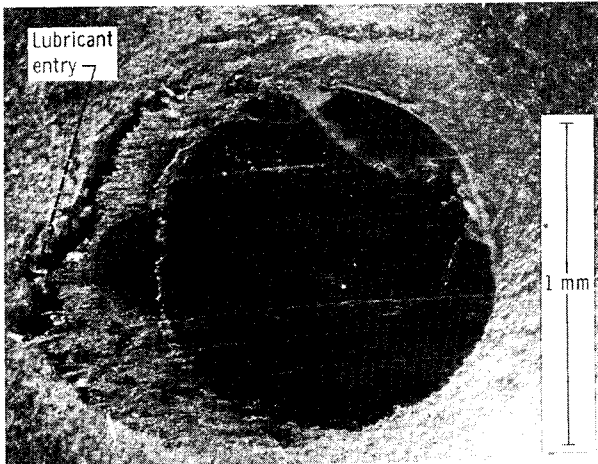
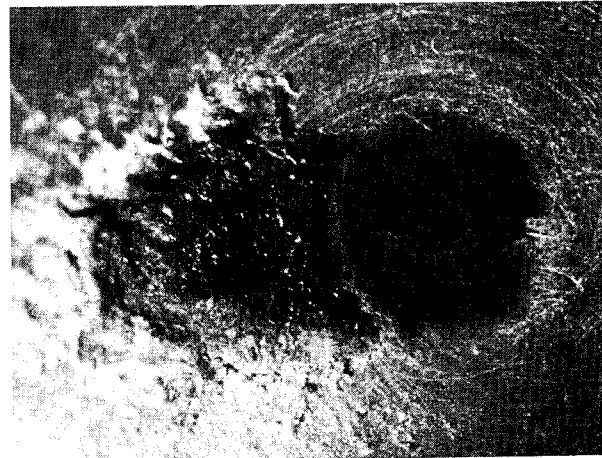

Figure 3. - Rider wear volume for three polymers in dry air at 260° and 23° C (500° and 73° F). Sliding speed, 10 meters per minute (390 in./min); load, 1.5 kilograms; lubricant, superrefined mineral oil; test duration, 25 minutes.



(a) Poly(amide-imide).



(b) Polyimide.

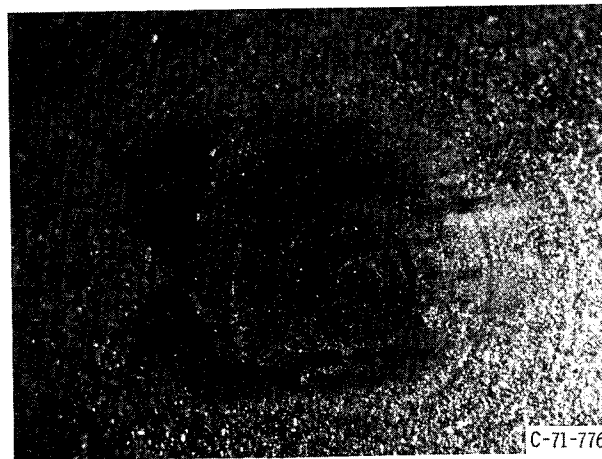

(c) Pyrrone.

Figure 4. - Typical rider wear scar for three polymers sliding on M-50 steel in dry air. Sliding speed, 10 meters per minute (390 in./min); load, 1.5 kilograms; disk temperature, 260° C (500° F); lubricant, superrefined mineral oil; test duration, 25 minutes.

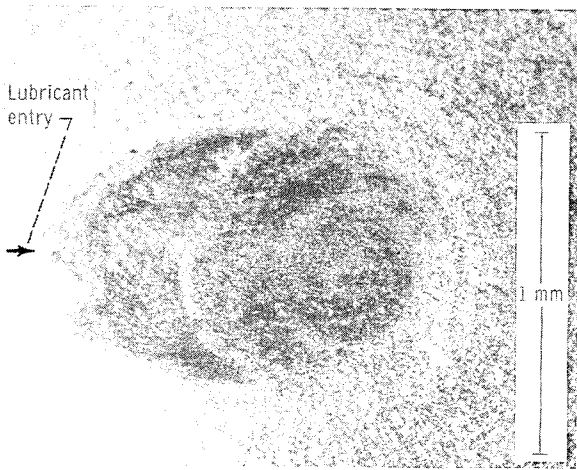

(a) Before scrubbing with alcohol.

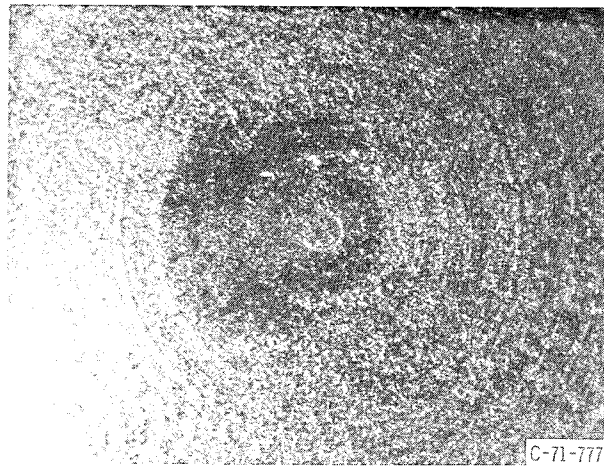

(b) After scrubbing with alcohol.

Figure 5. - Typical rider wear scar of pyrrone sliding on M-50 steel in dry air. Sliding speed, 10 meters per minute (390 in./min); load, 1.5 kilograms; disk temperature, 260° C (500° F); lubricant, superrefined mineral oil; test duration, 25 minutes.

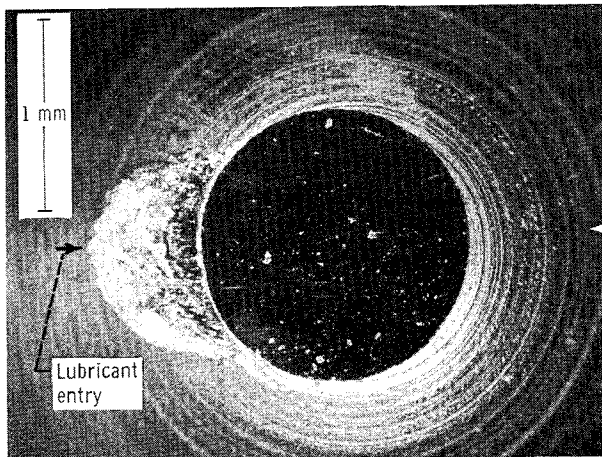

(a) No apparent thermal degradation.

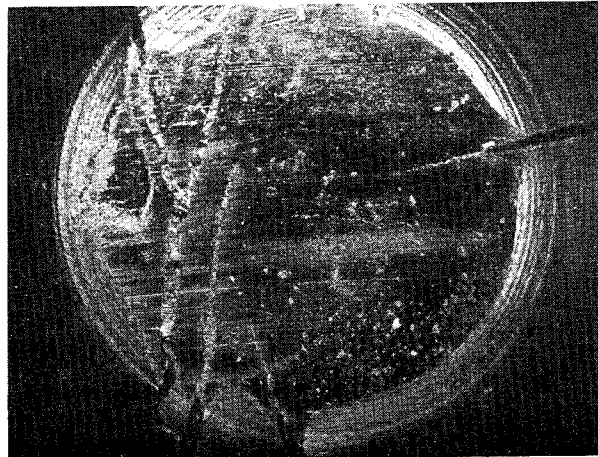

(b) Moderate thermal degradation.



(c) Severe thermal degradation.

Figure 6. - Three rider wear scars for polyamide-imide illustrating three degrees of thermal degradation in dry air. Sliding speed, 10 meters per minute (390 in./min); load, 1.5 kilograms; disk temperature, 260° C (500° F); disk, M-50 steel; lubricant, superrefined mineral oil; test duration, 25 minutes.

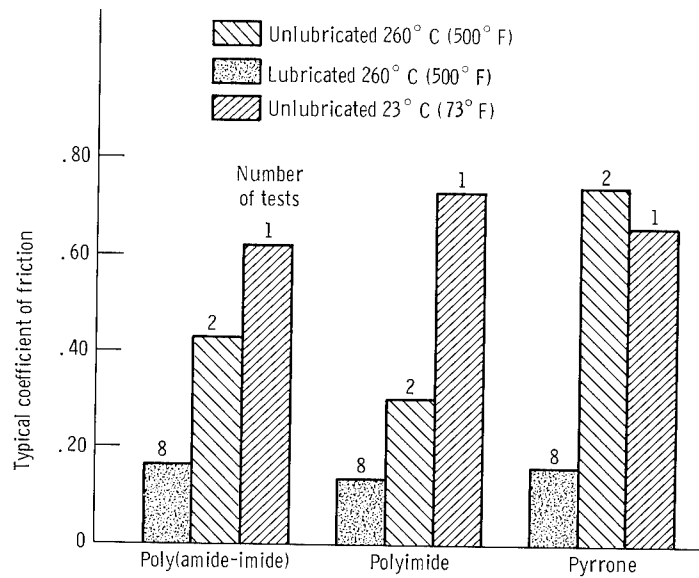

Figure 7. - Typical coefficient of friction for three polymers in dry air at 260° and 23° C (500° and 73° F). Sliding speed, 10 meters per minute (390 in./min); load, 1.5 kilograms; lubricant, superrefined mineral oil; test duration, 25 minutes.

NATIONAL AERONAUTICS AND SPACE ADMINISTRATION
WASHINGTON, D. C. 20546
OFFICIAL BUSINESS
PENALTY FOR PRIVATE USE \$300

FIRST CLASS MAIL



POSTAGE AND FEES PAID
NATIONAL AERONAUTICS AND
SPACE ADMINISTRATION

01U 001 40 50 3DS 71118 00942
PICATINNY ARSENAL
PLASTICS TECHNICAL EVALUATION CENTER
DOVER, NEW JERSEY 07801

ATT SMUPA-VP 3

POSTMASTER: If Undeliverable (Section 158
Postal Manual) Do Not Return

"The aeronautical and space activities of the United States shall be conducted so as to contribute . . . to the expansion of human knowledge of phenomena in the atmosphere and space. The Administration shall provide for the widest practicable and appropriate dissemination of information concerning its activities and the results thereof."

— NATIONAL AERONAUTICS AND SPACE ACT OF 1958

NASA SCIENTIFIC AND TECHNICAL PUBLICATIONS

TECHNICAL REPORTS: Scientific and technical information considered important, complete, and a lasting contribution to existing knowledge.

TECHNICAL NOTES: Information less broad in scope but nevertheless of importance as a contribution to existing knowledge.

TECHNICAL MEMORANDUMS: Information receiving limited distribution because of preliminary data, security classification, or other reasons.

CONTRACTOR REPORTS: Scientific and technical information generated under a NASA contract or grant and considered an important contribution to existing knowledge.

TECHNICAL TRANSLATIONS: Information published in a foreign language considered to merit NASA distribution in English.

SPECIAL PUBLICATIONS: Information derived from or of value to NASA activities. Publications include conference proceedings, monographs, data compilations, handbooks, sourcebooks, and special bibliographies.

TECHNOLOGY UTILIZATION PUBLICATIONS: Information on technology used by NASA that may be of particular interest in commercial and other non-aerospace applications. Publications include Tech Briefs, Technology Utilization Reports and Technology Surveys.

Details on the availability of these publications may be obtained from:

**SCIENTIFIC AND TECHNICAL INFORMATION OFFICE
NATIONAL AERONAUTICS AND SPACE ADMINISTRATION
Washington, D.C. 20546**