

19960318 017

DEVELOPMENT OF COMPOSITES TECHNOLOGY
FOR JOINTS AND CUTOUTS IN
FUSELAGE STRUCTURE OF
LARGE TRANSPORT AIRCRAFT



SEMIANNUAL TECHNICAL REPORT — NO. 1

PREPARED FOR LANGLEY RESEARCH CENTER
CONTRACT NAS1-17701
DRL ITEM NO. 008

DISTRIBUTION STATEMENT A

Approved for public release;
Distribution Unlimited

(33) = 3

DEPARTMENT OF DEFENSE
PLASTICS TECHNICAL EVALUATION CENTER
ARRADCOM, DOVER, N. J. 07801

Douglas Aircraft Company
3855 Lakewood Boulevard
Long Beach, California 90846

DTIC QUALITY INSPECTED 1

PLASTEC
44162

DOUGLAS AIRCRAFT COMPANY

3855 Lakewood Boulevard Long Beach, California 90846
TWX: 9103416842
Telex: 674357

ACEE-34-PR-3419

15 October 1984

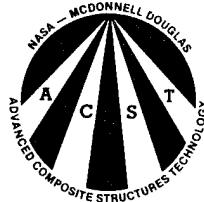

DRL ITEM NUMBER 008

DEVELOPMENT OF COMPOSITES TECHNOLOGY FOR
JOINTS AND CUTOUTS IN
FUSELAGE STRUCTURE OF LARGE TRANSPORT AIRCRAFT

SEMIANNUAL TECHNICAL REPORT - No. 1

FOR EARLY DOMESTIC DISSEMINATION

Because of its possible early commercial potential, this data, which has been developed under a U.S. Government program, is being disseminated within the United States in advance of general publication. This data may be duplicated and used by the recipient with the express limitation that it not be published. Release of this data to other domestic parties by the recipient shall be made subject to these limitations. Foreign release may be made only with prior NASA approval and appropriate export licenses. This legend shall be marked on any reproduction of this data in whole or in part. Date for general release will be three (3) years from date indicated on the document.

PREPARED FOR LANGLEY RESEARCH CENTER

CONTRACT NAS1-17701

MCDONNELL DOUGLAS

CORPORATION

ACEE-34-PR-3419

15 OCTOBER 1984

DRL ITEM NUMBER 008

Prepared by: *P. T. Sumida*
P. T. Sumida
Structures Engineering Manager
Composite Fuselage Program

Approved by: *D. J. Watts*
D. J. Watts
Project Manager
Composite Fuselage Program

Approved by: *M. Klotzsche*
M. Klotzsche
M. Klotzsche
Program Manager, CRAD and
Cooperative Technology Development

Prepared Under Contract NAS1-17701

McDonnell Douglas Corporation

FORWARD

This report was prepared by the Douglas Aircraft Company (DAC) of the McDonnell Douglas Corporation as part of a program to develop and demonstrate the technology required to use composites in fuselage structures of commercial and military transports by 1990. This first Semiannual Technical Report covers work accomplished between 21 March 1984 and 30 September 1984.

The program for Development of Composites Technology for Joints and Cutouts in Fuselage Structure of Large Transport Aircraft is sponsored by the National Aeronautics and Space Administration, Langley Research Center (LRC) under NASA Contract NAS1-17701. The Project Manager for DAC is Mr. D. J. Watts. Mr. H. L. Bohon is Project Manager for NASA, LRC. The Technical Representative for NASA, LRC is Mr. A. J. Chapman.

CONTENTS

SECTION		PAGE
1	INTRODUCTION	1
2	SUMMARY	5
3	DESIGN OPTIMIZATION	7
3.1	PRELIMINARY DESIGN	7
	DESIGN CRITERIA AND LOADS	7
	DESIGN GUIDELINES	8
	MATERIAL SELECTION	9
	FUSELAGE BARREL DESCRIPTION	10
	INTERNAL LOADS	13
	STRUCTURAL DETAILS	14
	JOINTS AND SPLICES	19
	CUTOUTS	22
3.2	DESIGN DEVELOPMENT	25
	JOINTS	25
	CUTOUTS	27
	STRUCTURAL TEST PLAN - PHASE I	27
	TEST DRAWINGS	29
	TEST ASSIGNMENT DRAWING	30
3.3	DESIGN METHODOLOGY	31
	ANALYSIS METHODS	31
	MATERIAL PROPERTIES	33
	EVALUATION OF PRELIMINARY TEST RESULTS	41
	ANALYSIS OF TEST SPECIMENS	45
4	PROCESS DEVELOPMENT AND FABRICATION	49
4.1	PROCESS DEVELOPMENT	49
	PROCESS DEVELOPMENT PLAN - PHASE I	49
4.2	TOOLING	51
5	REFERENCES	53

LIST OF FIGURES

FIGURE		PAGE
1	PROGRAM SCHEDULE	3
2	MD-100 GENERAL ARRANGEMENT	10
3	FUSELAGE BARREL SECTION	11
4	FUSELAGE SKIN PANEL	12
5	FUSELAGE LOAD DISTRIBUTION, STA. 1009	13
6	MARGINS OF SAFETY, SKIN SHEAR BUCKLING	15
7	LONGERON CROSS SECTIONS	16
8	FRAME AND SHEAR TEE	17
9	TYPICAL FRAME CROSS SECTION	18
10	SKIN SPLICES	20
11	FRAME SPLICE CONCEPT	21
12	PASSENGER WINDOW INSTALLATION	23
13	PASSENGER DOOR FRAME	24
14	JOINT CONFIGURATIONS	26
15	STRESS CONCENTRATION RELIEF DUE TO GLASS SOFTENING REGION	28
16	TYPICAL GROUP A SPECIMEN	29
17	BEARING BYPASS CURVES FOR T-300 AND IM6 LAMINATES	36
18	JOINT STRENGTH VERSUS BOLT SPACING FOR PSEUDO-ISOTROPIC LAYUP PATTERNS	38
19	JOINT STRENGTH VERSUS BOLT SPACING FOR 60/20/20 LAYUP PATTERNS	39
20	SHEAR TEE PULL-OFF MODEL	47
21	UNSTIFFENED CUTOUT MODEL	47
22	STIFFENED CUTOUT MODEL	48
23	PLASTIC LAMINATING MOLD	52

LIST OF TABLES

TABLE		PAGE
I	DESIGN CRITERIA AND LOADS (FAR-25)	7
II	DESIGN GUIDELINES	8
III	MECHANICAL TOUGHNESS AND PROCESSABILITY FACTORS - UNIDIRECTIONAL TAPE	9
IV	F584/IM6 PRELIMINARY MONOLAYER PROPERTIES	34
V	ESTIMATED F584/IM6 LAMINATE PROPERTIES	35
VI	PRELIMINARY SPECIMEN TEST RESULTS, F584/AS6 MATERIAL	42
VII	PRELIMINARY GROUP A ANALYSIS RESULTS	46
VIII	SUMMARY OF SOLVENT TESTS ON F584/IM6	49
IX	SUMMARY OF FABRICATION AND PROCESS VERIFICATION	50

SECTION 1
INTRODUCTION

Secondary composite structure for civil and military transport aircraft have been successfully developed under the NASA Aircraft Energy Efficiency (ACEE) Program. The cost and weight benefits of such composite structures have been validated by the design, manufacture and test of several components and confidence in these applications has been achieved through interface with the FAA and the airlines. These programs are nearing completion and the aircraft manufacturers are beginning to incorporate composite versions of such structures in plans for future aircraft.

While composites technology for secondary structures is now considered state-of-the-art, the major payoff will come with application of composites to primary structure, which comprises about 75 percent of transport structural weight. However, to reach this milestone, a comprehensive data base is needed to assure that both technical and financial risks are acceptable before incorporating these materials into safety-of-flight structure.

As a follow-on to the ACEE program, NASA established the Advanced Composite Structures Technology (ACST) program to develop a composite primary airframe structures technology base to achieve the full potential of weight and cost savings possible for U.S. civil and military transport aircraft in the early 1990's. As part of the ACST program, three large transport aircraft manufacturers have been contracted to address long-lead-time critical technology for composite fuselage structure which has been identified by NASA, other Government agencies, and industry-sponsored programs. This Development of Composites Technology for Joints and Cutouts in Fuselage Structure of Large Transport Aircraft was initiated in March 1984.

The baseline aircraft for this program is the MD-100, an advanced version of the DC-100, and the selected component is the forward fuselage barrel section approximately 30 feet in length. The constant section fuselage diameter is 237 inches. Frames are on a 20 inch spacing and longerons are spaced from approximately 6.5 inches to 7.5 inches. The forward fuselage barrel is of sufficient size and complexity to fully evaluate the technology issues of joints and cutouts.

The period of performance of this program is 30 months, with completion scheduled for September 1986. The program schedule is shown in Figure 1.

Technical information gathered during performance of this contract will be disseminated throughout the aircraft industry and the government. Information transfer will be accomplished through technical reports, industry briefings and technical workshops.

SECTION 2
SUMMARY

The component selected for design as part of this program is the forward fuselage barrel of the MD-100, an advanced derivative of the DC-10. Design criteria have been established and preliminary versions of a Structural Test Plan and Process Development Plan have been issued.

Preliminary design activities for the longitudinal and transverse skin splices and passenger door and window belt regions have been completed. Preliminary design of the fuselage frames, shear tees and longerons has also been completed. All of these design tasks are now in the Design Development Phase.

In Design Methodology, available methods for the analysis of joints, cutouts and post-buckling behavior were selected. Material properties data needed to accomplish a preliminary analysis of elements of the fuselage barrel and to facilitate analyses of the Group A (basic material behavior) specimens were obtained. Additionally, an in-house developed stress program was used to calculate estimated elastic and strength properties. These properties were used to generate bearing/bypass curves for the analysis of bolted joints.

An evaluation of preliminary test results was made on F584/AS6 material specimens. It was expected that these tests would provide some insight on the behavior of certain joint configurations. Preliminary analysis of the Group A test specimens has been completed and the analysis of the Group B specimens has begun.

The material system selected for the program is Hexcel F584/IM6. The material in tape and broadgoods form was ordered and delivery is expected in early October 1984. Ciba-Geigy woven Hercules carbon fiber with 8 mil aluminum wire and the American Cyanamid nickel coated Hercules carbon fiber will be impregnated with F584 resin by Hexcel for lightning protection tests.

The test program to develop and demonstrate the joints and cutouts includes small coupon size specimens to obtain basic material behavior properties to medium size panels and finally a large demonstration panel. This test article will be 9' X 14' with longitudinal and transverse splices and a representative door cutout. The panel will be subjected to simulated flight loads in a static and cyclic environment.

The first of the four groups of test drawings have been released for fabrication. This group of 10 drawings includes the monolayer data specimens, basic crossplied laminate data, unnotched specimens, and the unloaded hole specimens. The remainder of the specimens in this group include the single and double-lap joint specimens, compression after impact and a biaxial load specimen. Some preliminary data have been obtained with F584/AS6 material for initial sizing and analysis purposes.

The Materials and Process Engineering (M & PE) paper to provide inspection control of the test specimens in Group A was completed. The Engineering drawing delineating test conditions, loads, instrumentation requirements and supporting services such as photographic coverage was completed and ready for approval signatures.

For process development, the design and fabrication of the frame tool has been completed. Tool Design of the 9' X 14' demonstration panel laminating mold was completed and released for fabrication.

SECTION 3
DESIGN OPTIMIZATION

3.1 PRELIMINARY DESIGN

Design Criteria and Loads

The fuselage structure must be analyzed for an array of load conditions per Federal Aviation Regulations Part 25 (FAR 25). All critical ground and flight conditions are included. See Table I.

TABLE I
Design Criteria and Loads (FAR 25)

- **CABIN PRESSURE (P) IS 8.6 PSI + 0.5 PSI VALVE TOLERANCE**
- **FLIGHT CONDITIONS**
 - 2.5-g MANEUVER
 - CONTINUOUS GUST
 - LANDING IMPACT
- **FLIGHT-BY-FLIGHT REPEATED LOAD SPECTRUM**
 - ONE LIFETIME IS 60,000 FLIGHT HOURS
- **DESIGN ULTIMATE LOADS**
 - 2P ACTING ALONE
 - 1.5 (1P + LIMIT FLIGHT)
 - 1.5 (LIMIT FLIGHT)

Design Guidelines

A set of design guidelines has been compiled to provide a consistent basis for the conceptual design of the composite fuselage. The initial guidelines will be revised as design data and experience are gathered from the technology development. An ultimate design strain level of 0.0045 in./in. was used for the conceptual design on the basis of existing test data from the NASA Critical Wing Technology program. The accrual of damage tolerance technology will influence the selection of the final design strain levels.

TABLE II

Design Guidelines

THE DESIGN ULTIMATE STRAIN LEVEL IS 0.0045 IN./IN.

THE BENDING STIFFNESS (EI) OF THE COMPOSITE FRAMES AND LONGERONS IS EQUAL TO OR GREATER THAN THEIR BASELINE COUNTERPARTS

THE ALLOWABLE ONSET OF SHEAR BUCKLING IS 50 PERCENT OF LIMIT LOAD

THE MINIMUM SKIN GAGE IS 0.068 INCH

FRAME SPACING IS 20 INCHES

AVERAGE LONGERON SPACING IS 7.3 INCHES

MINIMUM THREADED FASTENER SIZE IS 3/16-INCH DIAMETER

MINIMUM FLAT AT BASE OF COUNTERSINK IN SKIN IS 0.010 INCH

Material Selection

The material system selected for this program is Hexcel F584 resin on 12K IM6 fiber. The tape will have a fiber areal weight of 145 g/M² and the broadgoods will be a 5 Harness Satin weave. The advantage in using the IM6 fiber is its high modulus compared to AS6 and CHS high strain fiber. See Table III.

TABLE III
 MECHANICAL, TOUGHNESS AND PROCESSABILITY FACTORS
 UNIDIRECTIONAL TAPE

	TEST TEMP (°F)	ENVIRONMENT	CIBA GEIGY 2566/CHS	FIBERITE 974/AS6	AMER. CYANAMID 1806/CHS	AMER. CYANAMID 1806/AS6	HEXCEL F584/CHS	HEXCEL F584/IM6
MECHANICAL								
SHORT BEAM	RT	RT DRY	18	16	14	14	19	18
(KSI)	200	200°F DRY	14	12	11	11	12	13
	200	200°F WET	9	9	8	8	10	10
COMPRESSION								
	RT	RT DRY	182	226	217	198	265	251
(KSI)	200	200°F DRY	165	200	178	208	205	189
	200	200°F WET	147	160	130	128	159	129
TENSILE (KSI)	RT	RT DRY	360	357	350	390	343	414
TEN. MOD. (MSI)	RT	RT DRY	21	22	19	19	20	26
% STRAIN			1.7	1.7	1.7	1.7	1.7	1.6
TOUGHNESS								
ST-1 (IMPACT COMP.)	RT		36	34	36	36	32	
ST-2 (Delamin)							.96	
ST-3 (TENS. HOLE)			62	68	64	64	52	
ST-4 (COMP. HOLE)			39	40			40	
ST-5 (GIC BEAM)	RT		2.19	1.3	1.5	1.5	1.3	
PROCESSABILITY								
1 (POOR)-5 (BEST)			5	5	5	5	5	5

Fuselage Barrel Description

The baseline aircraft selected for technology development is the latest derivative of the DC-10, namely the MD-100 (Figure 2). The component selected for this program is the forward fuselage barrel just ahead of the wing between fuselage stations 765 and 1129. The barrel section is 364 inches long and has a constant 118.5 inch radius. The section contains two 42 by 76 inch passenger doors, a 104 by 68 inch cargo door, 26 windows, 17 full frames, 19 floor beams and 103 longerons. See Figure 3.

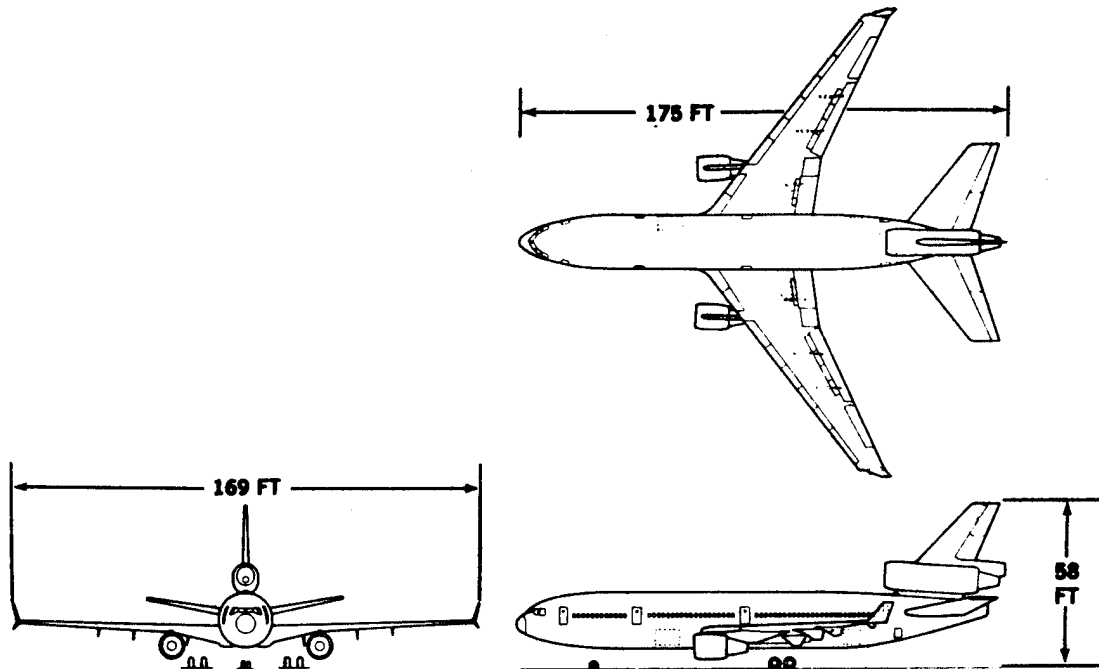

FIGURE 2 MD-100 GENERAL ARRANGEMENT

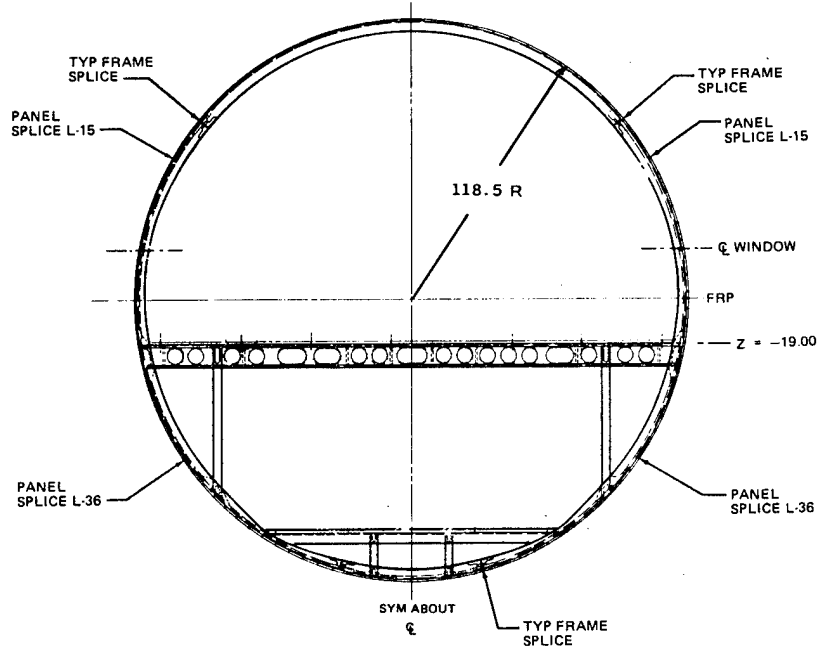
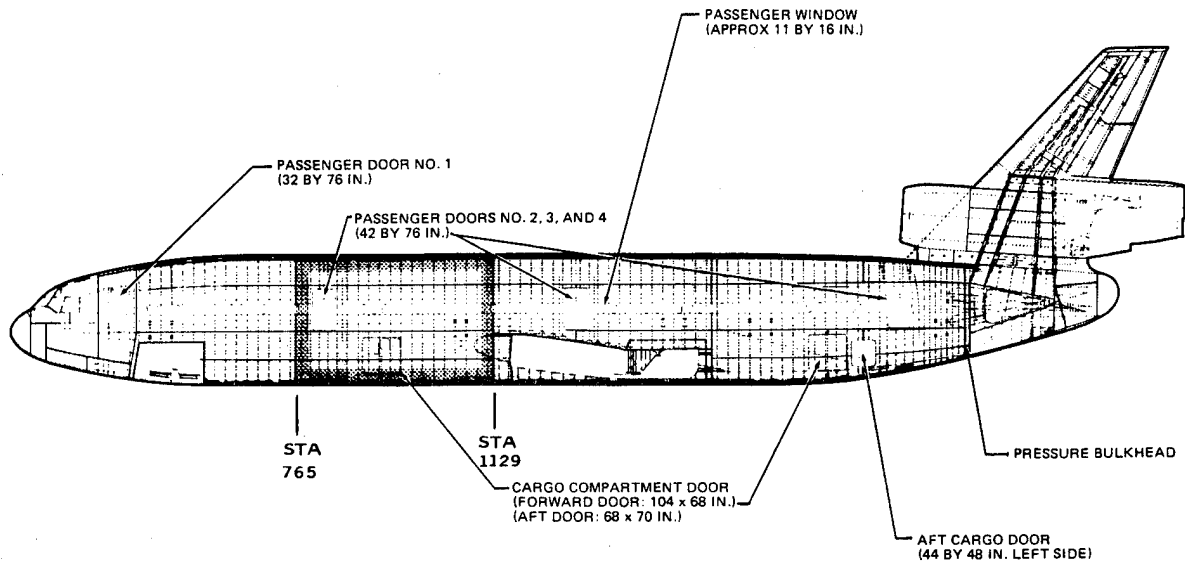

FIGURE 3 FUSELAGE BARREL SECTION

The fuselage concept consists of discrete structural elements which are built up to form the barrel section. Longerons and shear tees are secondarily bonded to the skin. Intersections between the longerons and frames are provided for by "mouse holes" in the shear tees at each longeron location to allow the longeron to pass through the shear tee and the frame to pass over the longeron as shown in Figure 4. Stability of the shell is enhanced by a shear clip between the frame and longeron at each intersection.

The shell is composed of four stiffened skin panels which are joined together with mechanically fastened joints to form a complete barrel section. A portion of a stiffened panel is shown in Figure 4. The floor beams, struts and frames are attached to the shear tees by fasteners. The barrel section is joined to the nose and aft fuselage sections by mechanically fastened skin and longeron joints.

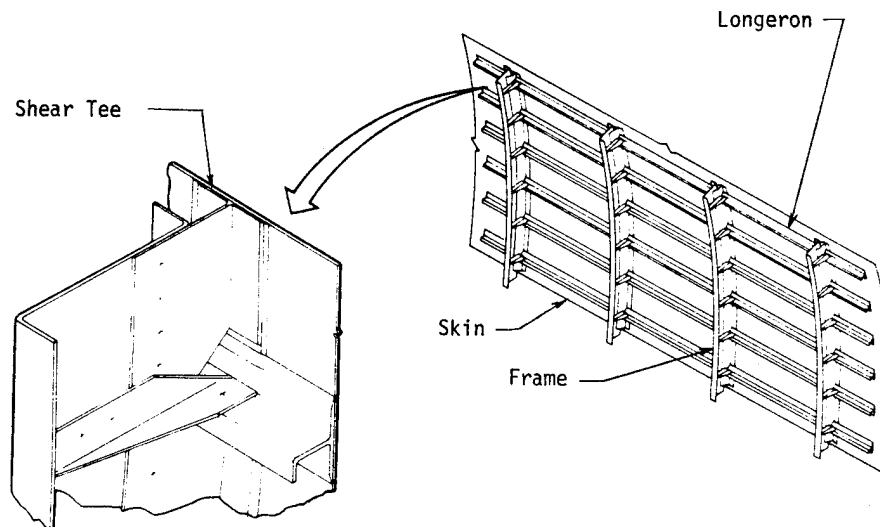

FIGURE 4 FUSELAGE SKIN PANEL

Internal Loads

A survey of the MD-100 fuselage internal loads was performed. These loads have been used to size the components of the composite conceptual design. The resulting stresses were compared against the applicable design criteria and margins of safety calculated. Station 1109 was selected to show a typical fuselage shell load distribution (Figure 5). The axial loads for tension (N_x max) and compression (N_x min) and maximum shear (N_{xy} max) are ultimate values.

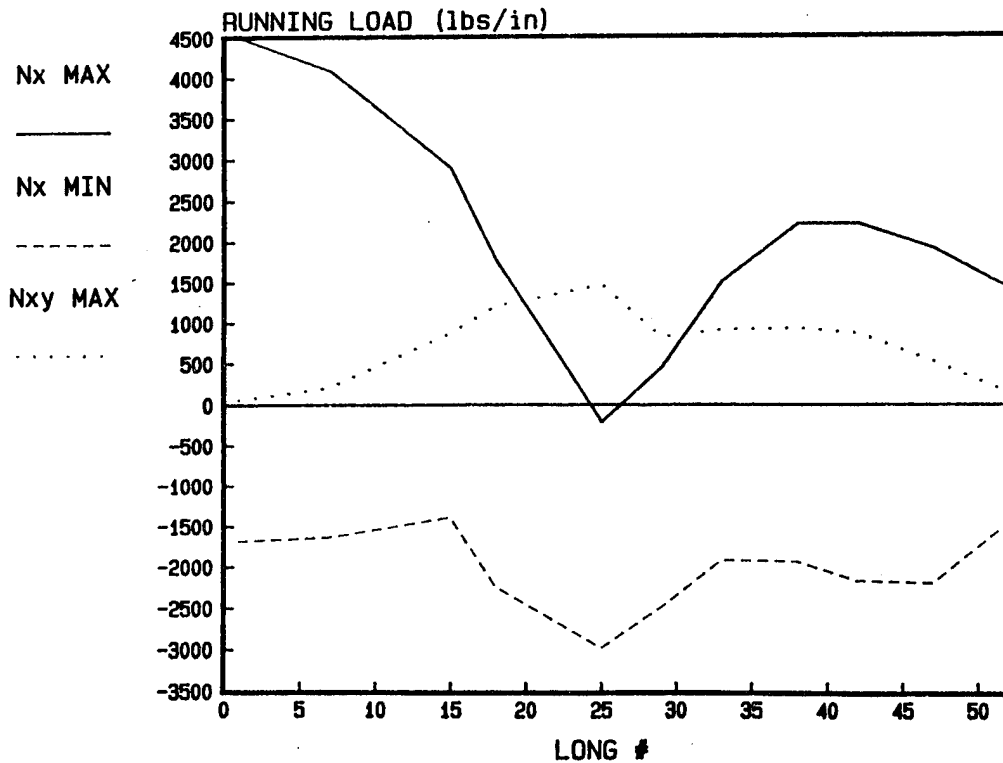

FIGURE 5 FUSELAGE LOAD DISTRIBUTION, STA. 1109

Structural Details

Fuselage Skin - The minimum gage skin is a $(0,90,+45,0,-45,90)_S$ material layup 0.068 inches thick. The skin provides hoop pressure and shear load carrying capability. The bending and longitudinal pressure loads are carried by both the skin and the longerons. Tape is used as the skin material to facilitate the use of automatic layup techniques in production.

Since the fuselage skin is in a swept stroke lightning attachment region it must be capable of withstanding a lightning re-strike without sustaining an unreasonable amount of damage. Ideally any damage that is received from a typical strike should be easily repairable by a non-structural cosmetic repair.

This level of lightning strike resistance will probably require the use of some type of skin protection. The layup of the outer two layers of tape have been designed so that they can be substituted by a biwoven cloth based lightning protection system. Either a nickel coated carbon fiber protection system or a system composed of fine aluminum wires woven into carbon cloth may be used.

The skins are reinforced to a pseudo-isotropic layup at the skin splices and cut-outs. Additional reinforcement is used near the rear of the barrel section to prevent premature shear buckling. The compression and shear buckling behavior of the skin was compared against the applicable design criteria and margins of safety for four fuselage stations are shown in Figure 6.

Longerons - The fuselage skins are stabilized by "J" section longerons which are secondarily bonded to the skin. The longeron cross section was selected as a result of the NASA fuselage study contract NAS1-17416. For simplicity and ease of manufacturing only two longeron layups are used. The flanges of the basic longeron consists of 33 percent zero degree material layup which is used in the majority of the fuselage barrel and a 60 percent zero degree layup material which is used in areas of high axial load such as the crown and keel regions. The basic and reinforced longeron sections are shown in Figure 7.

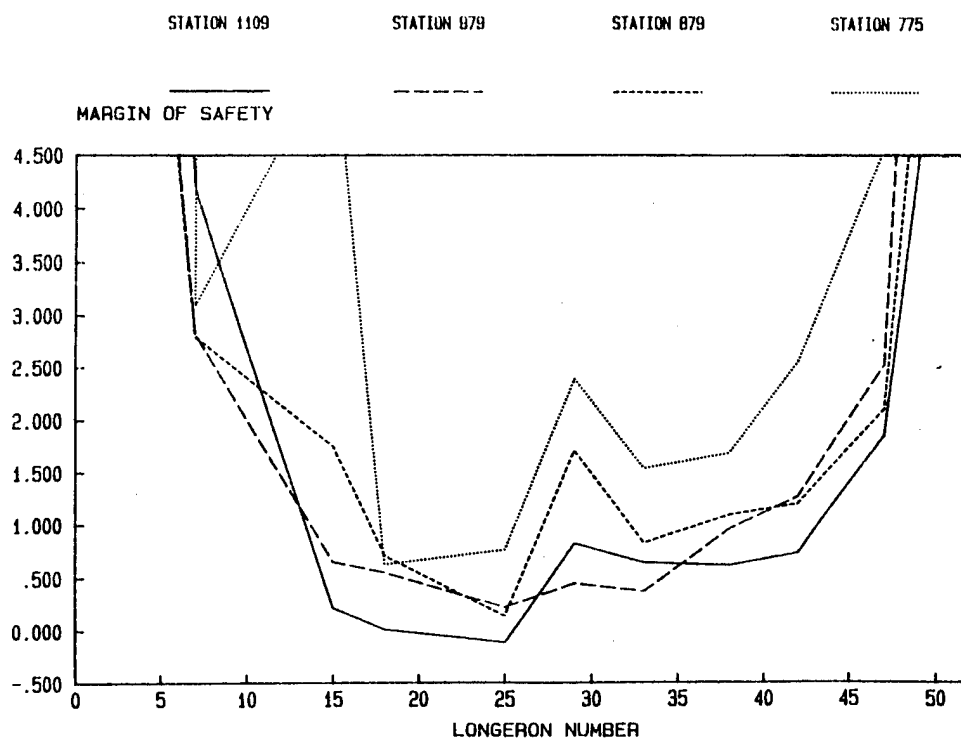
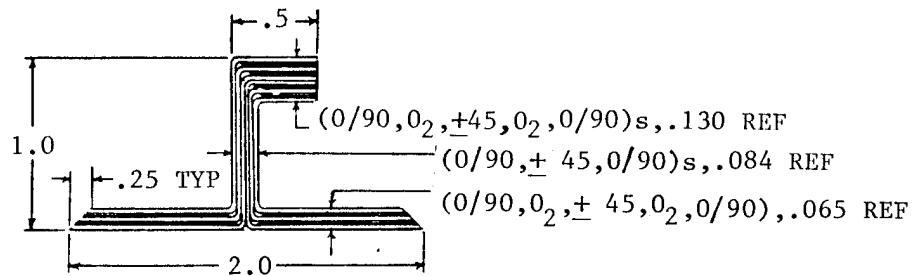
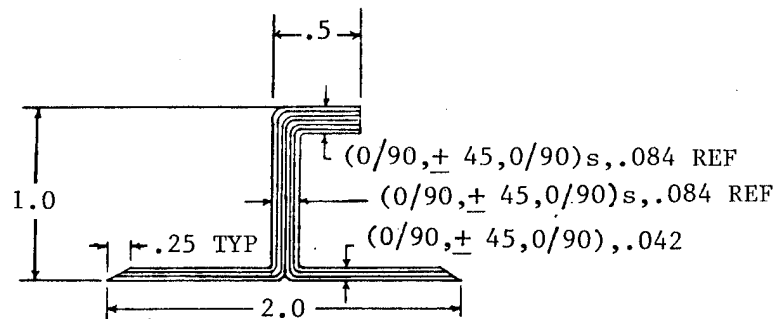

FIGURE 6 MARGINS OF SAFETY, SKIN SHEAR BUCKLING

Shear Tees - Shear tees are used to attach the skin panels to the frames. The shear tees have a pseudo-isotropic 8 ply web which divides to form a 4 ply pseudo-isotropic flange. Cloth material is used in the manufacture of the tees for enhanced drapability. A "T" cross section is used for bonding efficiency, the bonded flange is 2 inches wide. The shear tees are secondarily bonded to the skins with FM 300 adhesive. A frame-shear tee combination is shown in Figure 8.



Reinforced section



Basic section

FIGURE 7 LONGERON CROSS SECTION

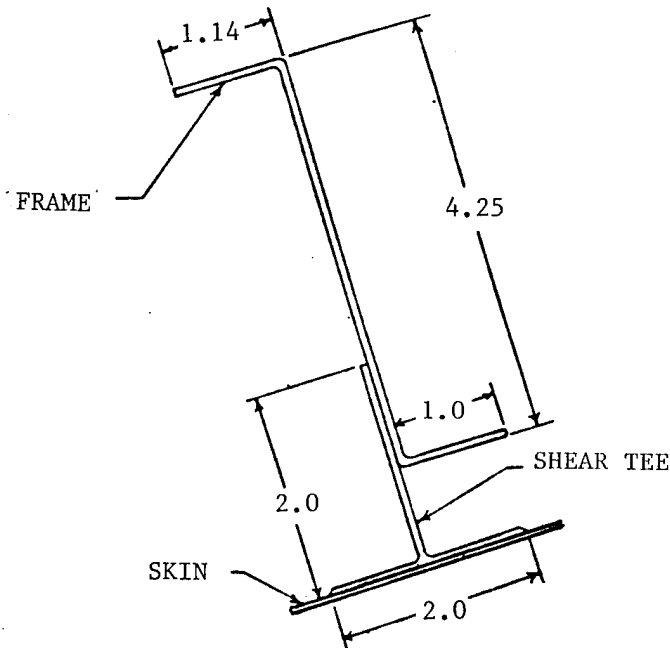

FIGURE 8 FRAME AND SHEAR TEE

Frames - Frames are used to support the skin panels through the shear tees and the longerons. The frames consist of a "Z" cross section with pseudo-isotropic webs. The flanges have a layup containing as much as 60 percent of zero degree material. A pseudo-isotropic layup pattern is used for the webs as a practical overall solution to a set of somewhat conflicting requirements. Considerations of varying shears at any given frame section, ease of analysis and manufacture and the practical limitations on the range of thicknesses dictates the selection of the above layup pattern. The webs are made of cloth while the flange reinforcement is tape. The frames are mechanically attached to the shear tees and shear clips. A typical frame cross section is shown in Figure 9.

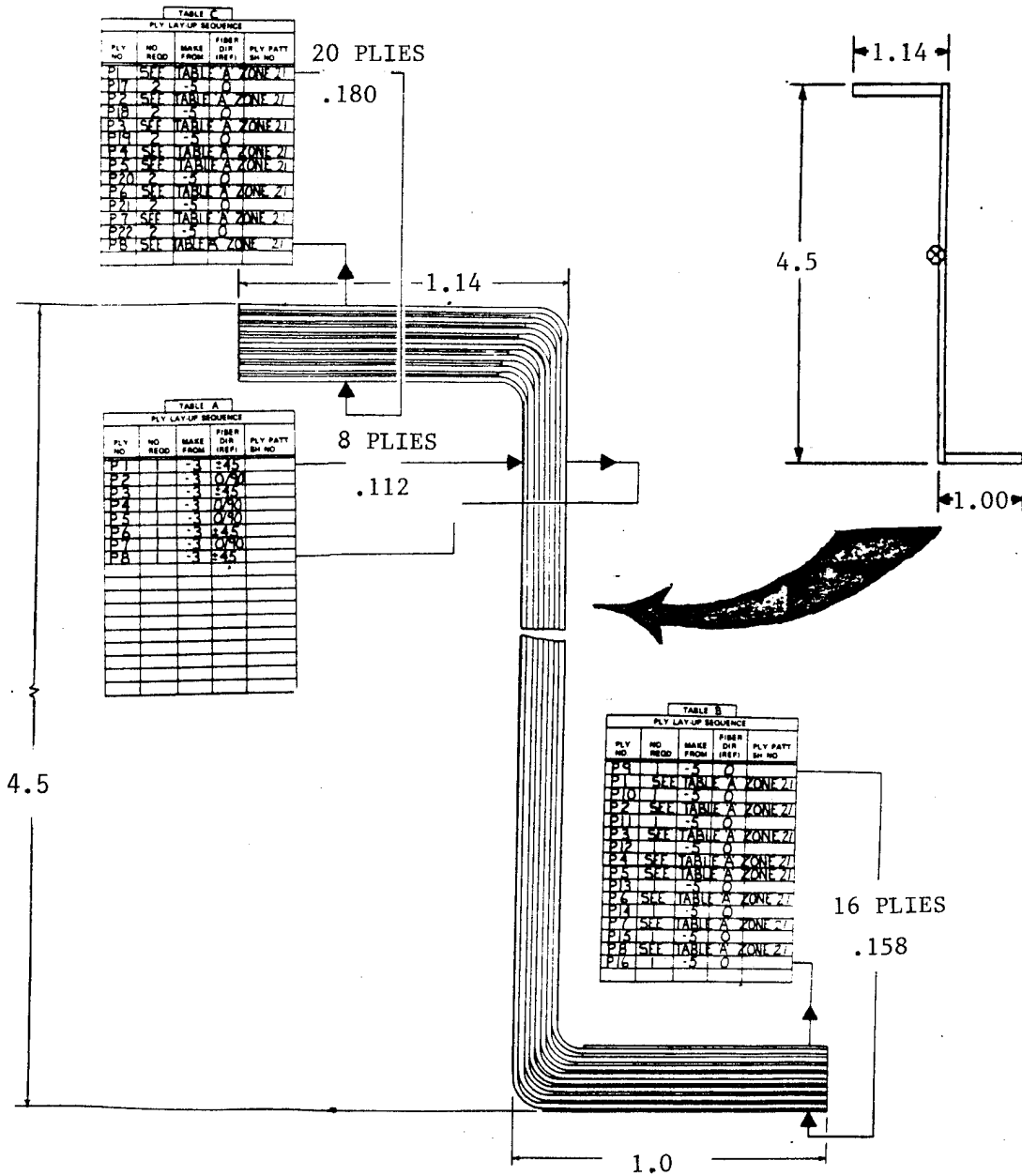

FIGURE 9 TYPICAL FRAME CROSS SECTION

JOINTS AND SPLICES

Skin Splices - Two distinctly different types of skin splices are used in the fuselage shell, these are the longitudinal and transverse splices. The preliminary design of a longitudinal splice is a double shear splice with an external splice strap and an internal splice strap which is also the base of a longeron. The splice contains two rows of countersunk titanium fasteners. The outer splice is designed by counter-sink depth requirements.

The transverse splice must be aerodynamically flush which requires the use of a single shear splice. The skin is reinforced in the splice region to provide sufficient thickness for countersink depth requirements. The skin is reinforced to a 0.091 inch thick pseudo-isotropic layup. The conceptual transverse joint design is a single shear two step lap joint with four rows of fasteners. The transverse and longitudinal skin splice concepts are shown in Figure 10.

Longeron Joint - The longeron cross sections are changed from a "J" section to a blade section just before crossing a skin splice. The blade section longeron is ended at the skin splice strap. The longerons are spliced at the skin splices with "L" section splice straps which span the skin splice strap. The splice straps are attached to the longerons with three rows of mechanical fasteners. In addition, the flanges of the splice straps are attached to the skin and skin splice straps by mechanical fasteners.

Frame Joints - Two frame splice concepts have been under active investigation. The first concept is a simple double lap joint. The second concept is a tailored combination single-double lap joint. The material in the frame caps may contain as much as 60 percent zero degree material. This results in a very high tension or compression allowable but not a corresponding increase in the

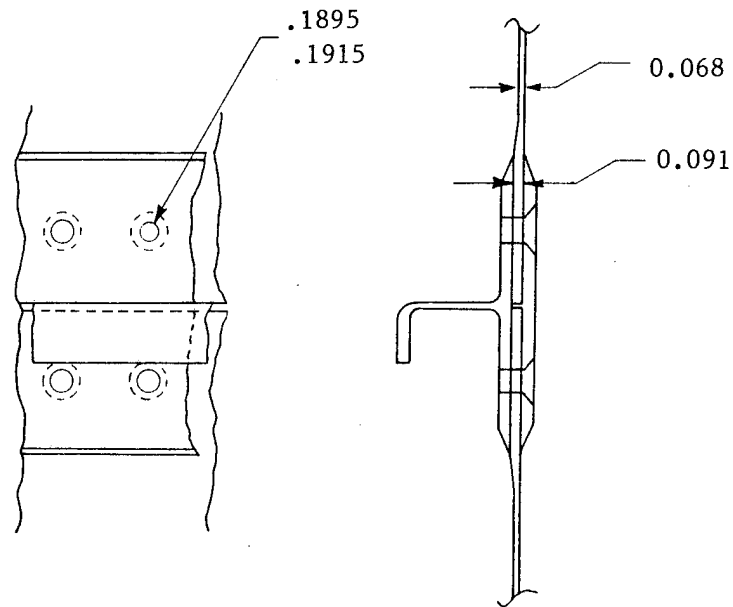

LONGITUDINAL SPLICE

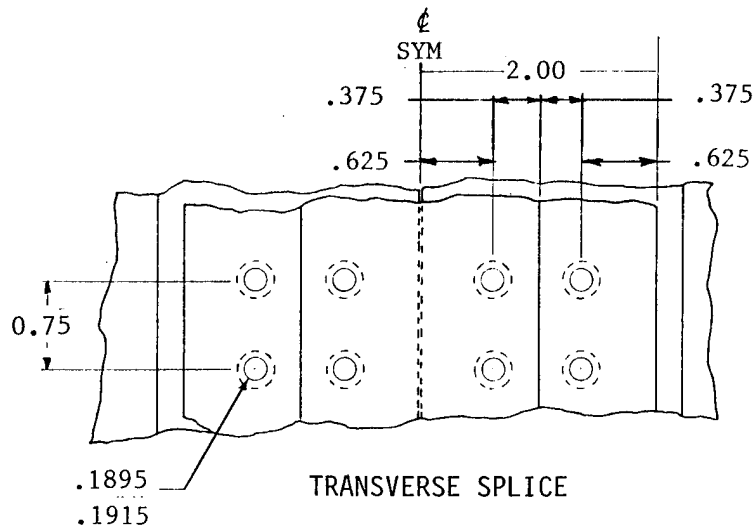
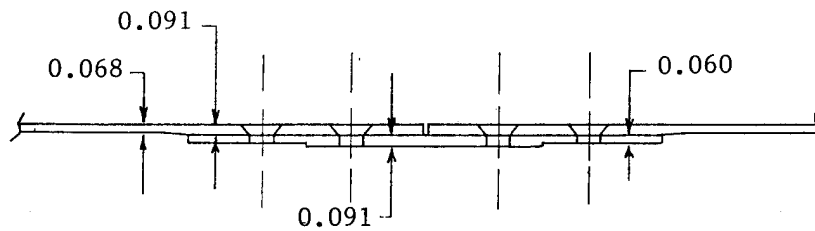

TRANSVERSE SPLICE

FIGURE 10 SKIN SPLICES

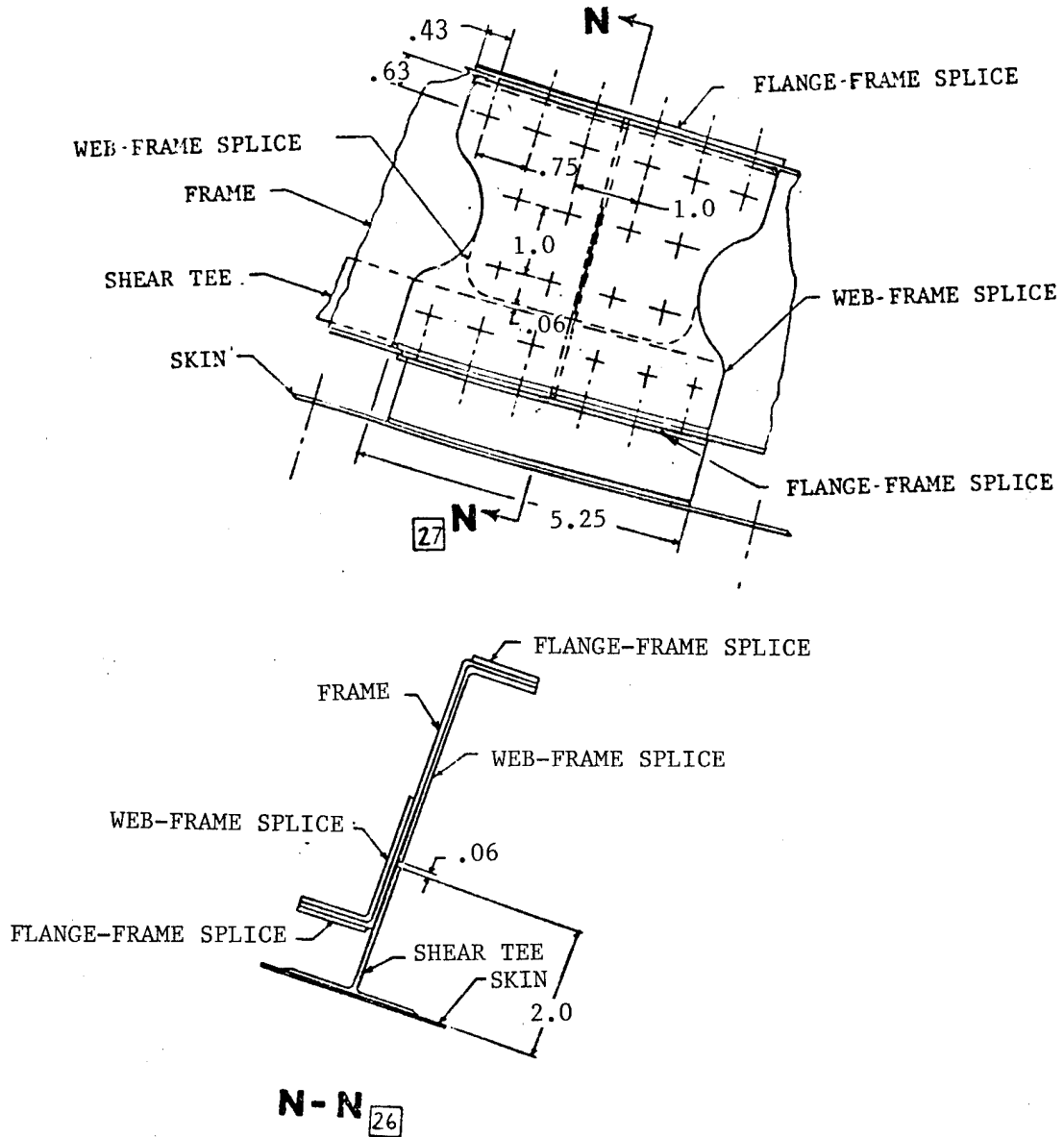

FIGURE 11 FRAME SPLICE CONCEPT

bearing allowable. For this reason six row mechanically fastened joints are used in both concepts. Because of the uncertainty in splicing laminates containing high percentages of fibers in one direction, both splice concepts were tested under a DAC funded program. The results of the program indicated that both concepts meet the strength requirements of a fuselage frame. The tailored concept was stronger than the simple concept but it was also slightly more expensive to manufacture. Because the increase in strength was too small to justify the added manufacturing cost, the tailored concept has been dropped from active consideration. Therefore concept 1, the simple double lap joint shown in Figure 11, is the current preferred frame joint method.

CUT-OUTS

The baseline fuselage design contains both window, passenger and cargo door cutouts. The reinforcement around the windows consists of a window belt doubler. This doubler extends 9 inches above and 9 inches below the windows. The doubler consists of pseudo-isotropic material and is a maximum of 0.33 inches thick excluding the skin.

The window frame, which is not pressure loaded is adhesively bonded to the skin. The window belt and window frame are shown in Figure 12.

The passenger door cut-out in the skin is reinforced with a general field doubler. The door corners have an additional localized skin doubler to reduce the stresses in this area. The door is framed with jamb and stud frames and upper and lower headers. The door pressure loads are reacted by door stops which are attached to the jamb frames. Intercostals form a torsionally rigid cut-out support and help redistribute the shell loads around the door. An overall view of the door region is shown in Figure 13.

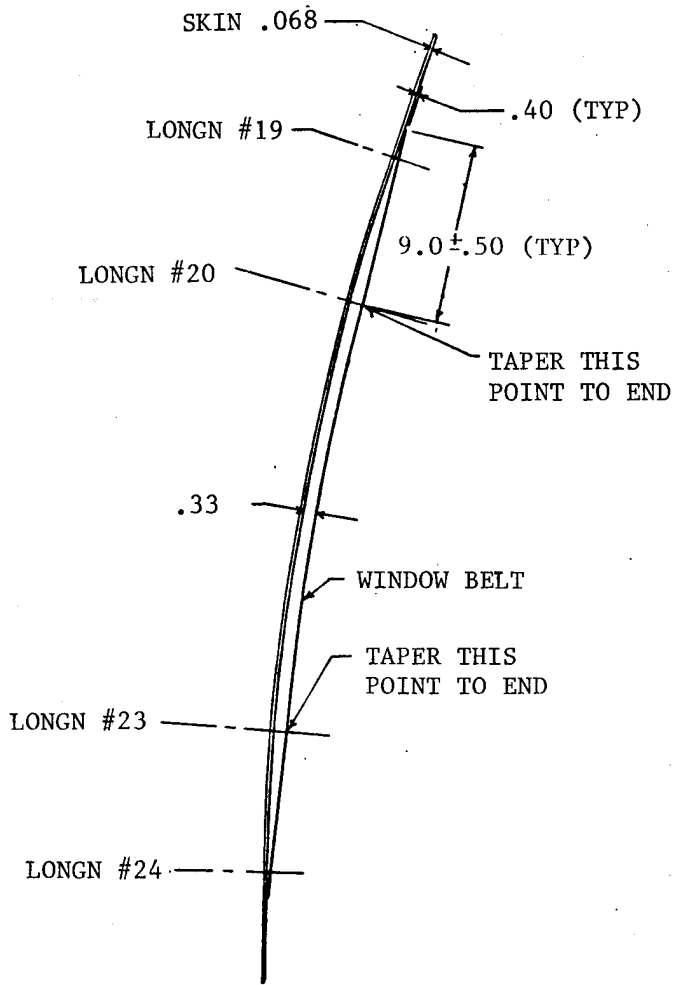

WINDOW BELT REINFORCEMENT

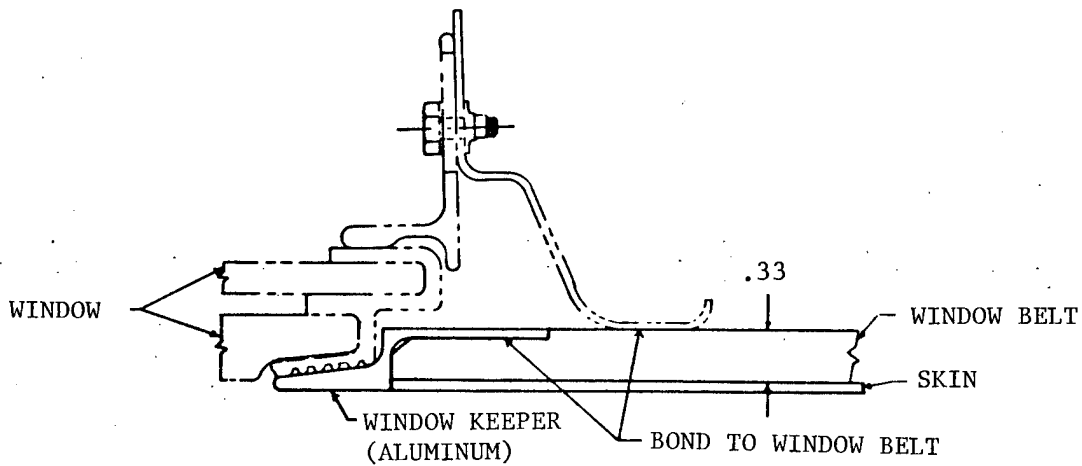

FIGURE 12 PASSENGER WINDOW INSTALLATION

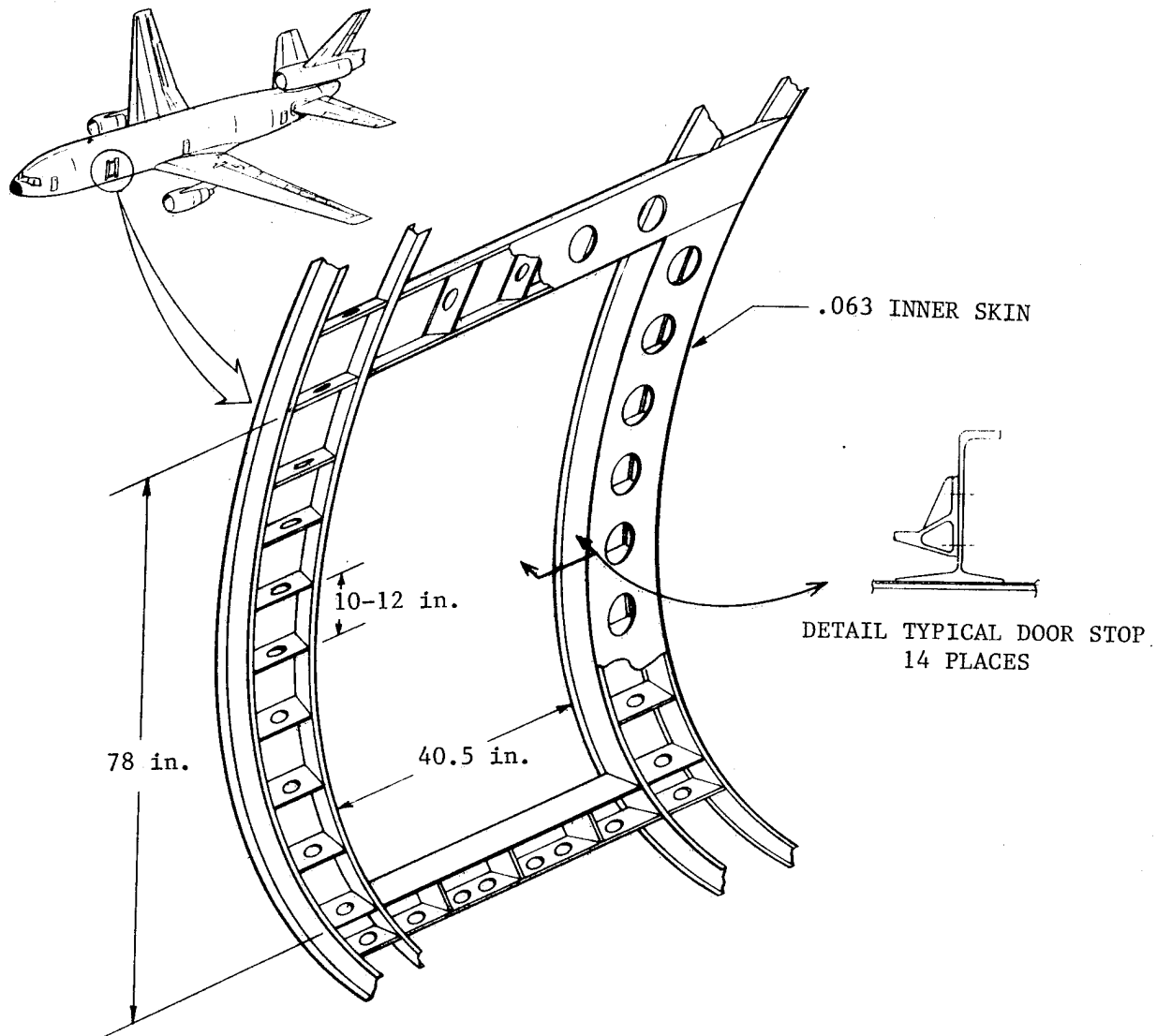

FIGURE 13 PASSENGER DOOR FRAME

3.2 DESIGN DEVELOPMENT

The Design Development task is the logical next step in the design optimization process which further refines the preliminary design concepts. Producibility and inspectability are the major considerations leading to a high degree of practicability.

Joints

Two configurations of each type of skin joint have been defined. These longitudinal and transverse joint concepts are shown in Figure 14.

The first longitudinal concept is similar to the configuration used in the conceptual fuselage design. Only two rows of fasteners are used instead of the multiple rows more commonly used in current designs. Even though a multiple row joint would be stronger, two rows of fasteners are sufficient to carry the required ultimate load. The use of only two rows of fasteners will reduce manufacturing costs. The second concept is a completely different design utilizing a lap joint as shown in Figure 14. The joint is designed in such a way as to minimize the bearing stresses at the first row of fasteners where the bypass stress is high.

Two transverse joint concepts have been developed. The first is identical to the concept shown in the preliminary fuselage design. This is a step lap joint with a single splice plate and a flush outer surface. The second concept utilizes a reverse step lap in order to reduce the bearing-bypass stresses at the first fastener in the joint (Figure 14). This joint should be more efficient than the first concept from a structural point of view but more difficult to manufacture. The structural efficiency and manufacturing potential of both concepts are being compared.

Longitudinal Splice

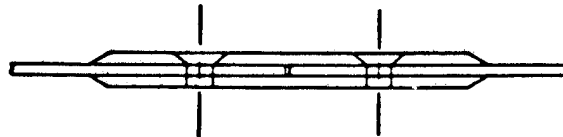

concept 1

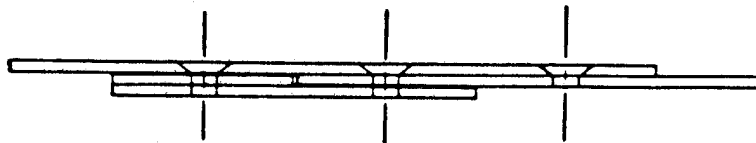

concept 2

Transverse Splice

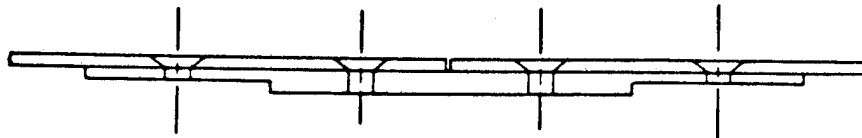

concept 1

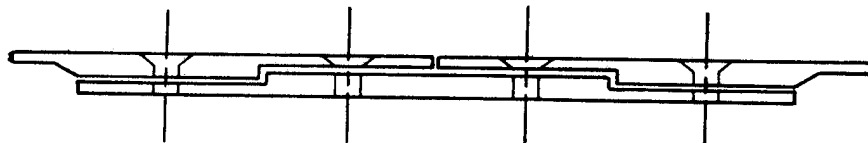

concept 2

FIGURE 14 JOINT CONFIGURATIONS

CUT-OUTS

The development of softening techniques for reducing the stress concentrations at the edges of cutouts has begun. Figure 15 gives results from a finite element model of a cutout under unidirectional axial load. An all carbon/epoxy unreinforced configuration was compared to a configuration which had the carbon 0 and 90 degree tape plies at the hole boundary substituted by fiberglass/epoxy cloth. As shown in Figure 15, the maximum stress at the edge of the hole has been reduced 35 percent and the location of maximum stress has been moved away from the hole boundary. Work is continuing to characterize the softened cutout behavior for shear and biaxial stress cases and to evaluate the potential for incorporating this technique in actual aircraft structure under combined loading conditions.

STRUCTURAL TEST PLAN PHASE I

A preliminary Structural Test Plan - Phase I was prepared. The plan delineates the number, type and schedule of tests. The test specimens are divided into two major categories, namely, development specimens and technology demonstration tests. The first category of specimens are subdivided into three groups i.e., basic material behavior (group A), cutouts and basic structure (group B) and joint test specimens (group C). The latter group are divided into two subgroups. Three 4' by 5' shear/interaction panels are included in this series of tests. The final test specimen is a large 9' by 14' demonstration panel with longitudinal and transverse splices and a large cutout.

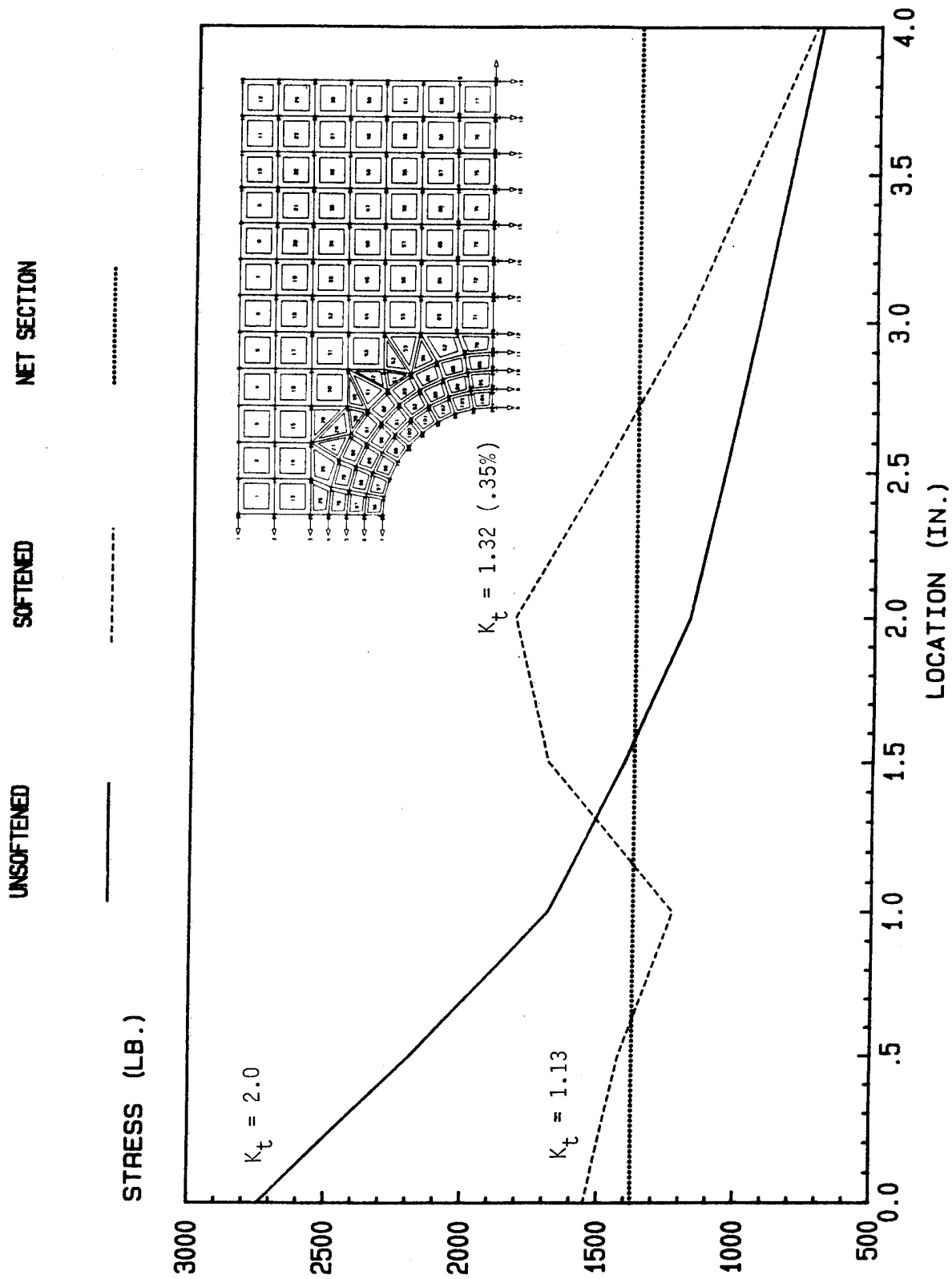
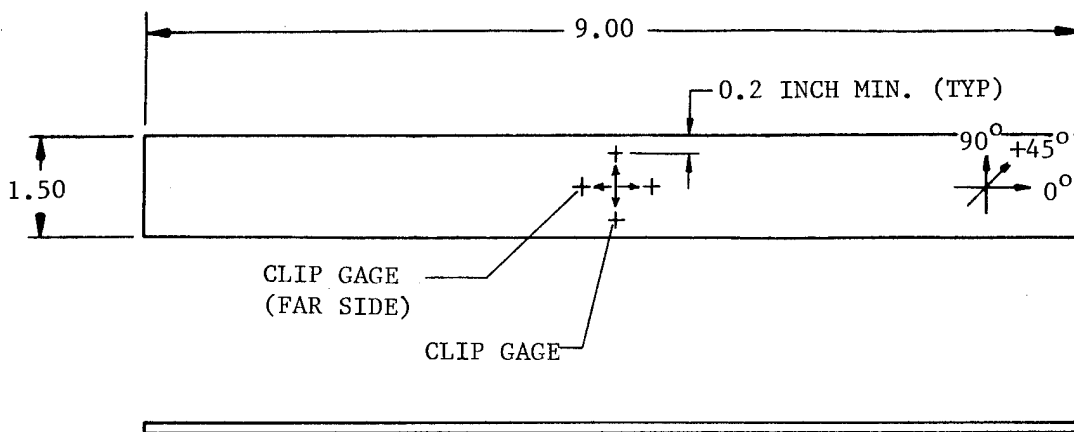

FIGURE 15 STRESS CONCENTRATION RELIEF DUE TO GLASS SOFTENING REGION

TEST DRAWINGS

The group A test drawings have been completed and released. Engineering drawings of the group B are nearing completion. The group C test drawings are being prepared. An example of a group A drawing is shown in Figure 16.



SPECIMEN	TEST	CONFIGURATION	LAYUP/MAT'L	LOAD	REPLICATE
I	MONOLAYER STRENGTH	-501	0°/TAPE	TEN.	3
		-503	90°/TAPE	TEN.	3
		-505	0/90°/CLOTH	TEN.	3
TOTAL					9

PURPOSE: Determine lamina tension strength and moduli in the longitudinal and transverse direction.

INSTRUMENTATION: MTS clip gages in the 0° and 90° directions as shown.

DATA REQUIRED: Load/strain readings in the 0° and 90° directions and failure load.

FIGURE 16 TYPICAL GROUP A SPECIMEN

TASK ASSIGNMENT DRAWING

The Task Assignment Drawing (TAD) for the Group A tests is complete and is in the approval process. This document defines the procedures for each test including the test preparation, loading conditions, data recording requirements and other test related items including purpose of the test.

3.3 DESIGN METHODOLOGY

ANALYSIS METHODS

A survey of available methods for the analysis of joints, cutouts and post-buckling of composite laminates led to the choice of the following:

Uniaxial Loading - Methods have been developed under NASA contract NAS1-16857 for the analysis of uniaxially loaded bolted joints in composites (Reference 1). The basic theory assumes that elastic stress concentrations around a bolt hole, (which can be readily calculated using classical formulae), can be applied to a composite joint after having been reduced by a relief factor, (the "C" factor). Applying these reduced stress concentration factors to the cases of "all bearing" and "all bypass" yield the loaded hole and unloaded hole strengths respectively. The stresses from bearing loads and bypass loads are assumed to add at the side of the hole, which defines the bearing/bypass curve as a straight line connecting the loaded and unloaded hole strengths. The theory requires that the load distribution in a multi-row joint, (and therefore the amounts of bearing and bypass load at each fastener), be known. A4EJ, a program developed at Douglas under Air Force contract, has the capability of calculating these bolt load distributions while accounting for joint geometry, hole clearance, and bearing yield effects. More complicated joint geometries, (with multiple load paths), require the use of finite element analyses to determine the load sharing. These methods have been proven for thick laminates but have yet to be verified for the very thin laminates which comprise fuselage structure. Neither have they been thoroughly tested in compression.

Biaxial Loading - One option for analyzing biaxially loaded cases is simply an extension of the method used for the uniaxial case. With this method, elastic stress distributions around the hole are assumed for each of the bearing, bypass and shear components. These distributions are then reduced by a "C factor" which varies around the hole, and then added. This technique has been used with success on the DC-10 composite vertical stabilizer program NAS1-14869. Another possibility is the program BJSFM, developed at McDonnell Aircraft Company under Air Force contract (Reference 2). As with the previous method, stress distributions are calculated around the hole for each of the bearing, bypass and shear components. These elastic distributions are then superimposed, and examined at an experimentally determined "characteristic radius" from the center of the hole. As the stresses drop off radially from the edge of the hole, using a characteristic radius larger than the actual radius accounts for the relief effect. The choice between these two methods will be determined by how well test data is matched and ease of use.

Cutouts - For simple cut-outs in flat plates, classical elastic stress concentration factors can be used. The more complicated geometries will be modeled using finite element techniques. The question that remains to be answered is whether any relief effects, as have been demonstrated around bolt holes, exist for large cutouts.

Postbuckling Behavior - NASTRAN finite element models will be used to predict the onset of buckling as well as postbuckling behavior. A buckling analysis (RIGID FORMAT 5) will predict the onset of buckling and the mode shape. A geometric nonlinear analysis (RIGID FORMAT 64), using the first buckling mode with a peak amplitude of 1.0 percent of the skin thickness as the initial shape, can then be performed at various load levels to determine postbuckling behavior. Similar techniques have been used with excellent results

by Agarwal, Renieri and Garrett, and others. (References 3 and 4)

MATERIAL PROPERTIES

In order to facilitate analysis prior to the testing of the Group A specimens, a preliminary set of monolayer data has been assembled based on vendor data (F584/IM6) and Lockheed test results (F584/CHS). The Lockheed material system contains CHS fiber rather than IM6 fiber and therefore is used only for resin dominated properties. Other properties were taken from vendor data sheets. Where a particular property was not available from either source, the property was estimated based on past experience. These properties, given in Table IV, are considered adequate for initial design purposes. As Group A testing proceeds these properties will be updated accordingly.

A Douglas developed program STRENGTH, which uses the Ashizawa-Black failure criterion, was used to calculate elastic properties and unnotched strengths for various laminates. The calculated values for four laminates which will be used in the fuselage design are given in Table V.

The effects of these higher allowables on joint strengths, (as compared to laminates composed of first generation "T300 type" fibers), are illustrated by Figure 17. The bearing/bypass curves are drawn for a bolt pitch/bolt diameter (p/D) of four, for two layups, for both materials. The layups are pseudo-isotropic (25/50/25) and 60 percent 0's (60/20/20). These curves are plotted as gross stresses (load divided by the quantity bolt pitch times panel thickness). Some preliminary coupon tests have indicated that, although the tension strengths are appreciably higher with the IM6 fiber, the bearing strengths are not. Thus these curves assume the same bearing allowable, (i.e. the same bearing cutoff), for

TABLE IV
 F584/IM6 PRELIMINARY MONOLAYER PROPERTIES

F_L^t	LONGITUDINAL TENSION STRENGTH	350	KSI
E_L^t	LONGITUDINAL TENSION MODULUS	24	MSI
ν_{LT}	POISSON'S RATIO	.283	
F_{LT}	SHEAR STRENGTH	20.71	KSI
G_{LT}	SHEAR MODULUS	.81	MSI
F_T^t	TRANSVERSE TENSION STRENGTH	4.71	KSI
E_T^t	TRANSVERSE TENSION MODULUS	1.35	MSI
F_L^c	LONGITUDINAL COMPRESSIVE STRENGTH	251	KSI
E_L^c	LONGITUDINAL COMPRESSIVE MODULUS	20	MSI
F_T^c	TRANSVERSE COMPRESSIVE STRENGTH	18	KSI
E_T^c	TRANSVERSE COMPRESSIVE MODULUS	1.35	MSI
μ_{MAX}	FAILURE STRAIN	15000	$\frac{\mu in}{in}$
	NOMINAL THICKNESS PER PLY	.0057	in
ρ	DENSITY	.054	$\frac{LB}{FT^3}$

TABLE V ESTIMATED F584/IM6 LAMINATE PROPERTIES

LAMINATE %0°/%±45°/%90°	APPLICATION	PROPERTIES							
		E _x (Msi)	E _y (Msi)	G _{xy} (Msi)	F _x ^{TU} (Ksi)	F _y ^{TU} (Ksi)	F _x ^{CU} (Ksi)	F _y ^{CU} (Ksi)	F _{SH} (Ksi)
33/33/33 12 PLY TAPE	BASIC SKIN	10.51	10.51	2.60	139	139	109	109	52
25/50/25 16 PLY TAPE	SKIN PAD-UP	9.11	9.11	3.49	113	113	97	97	70
60/20/20 20 PLY TAPE & CLOTH	HI-LOAD LONGERONS & FRAME CAPS	15.91	6.98	1.90	223	86	166	73	38
33/33/33 6 PLY CLOTH	BASIC LONGERON	10.51	10.51	2.60	139	139	109	109	52

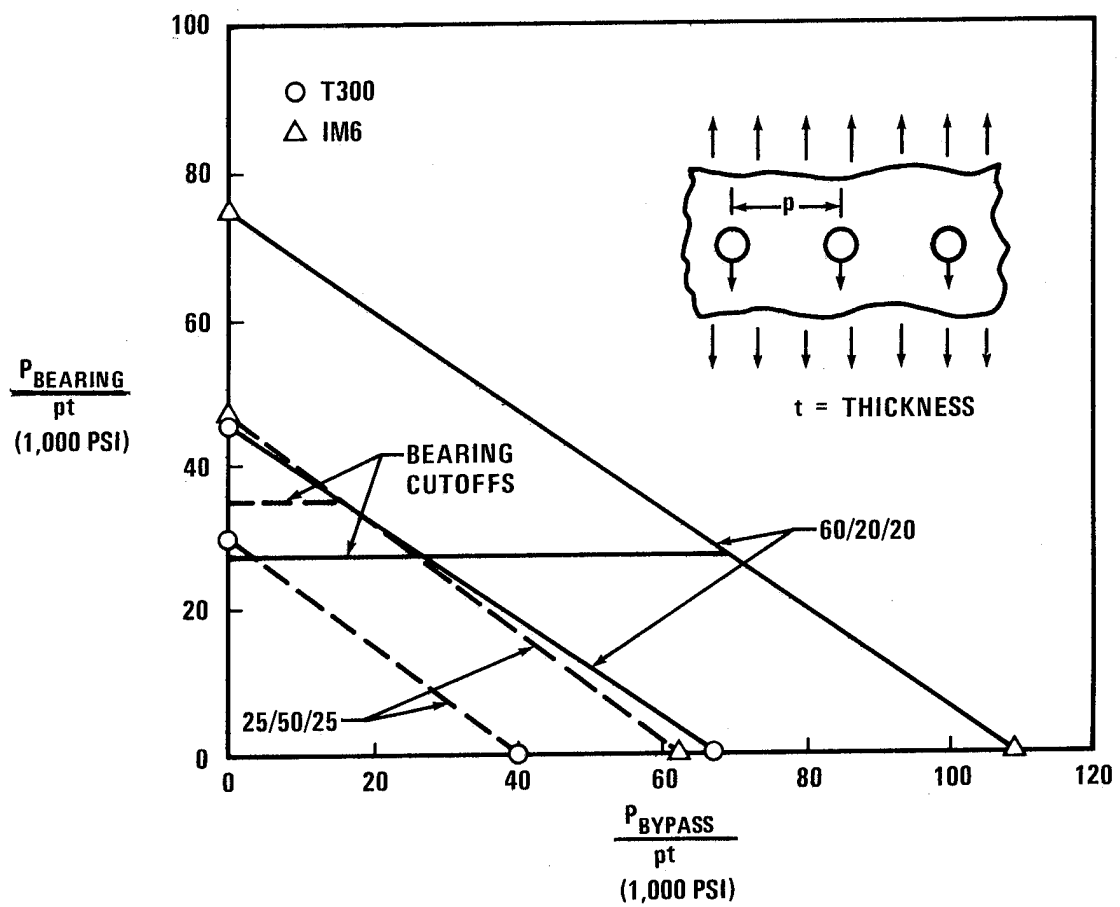
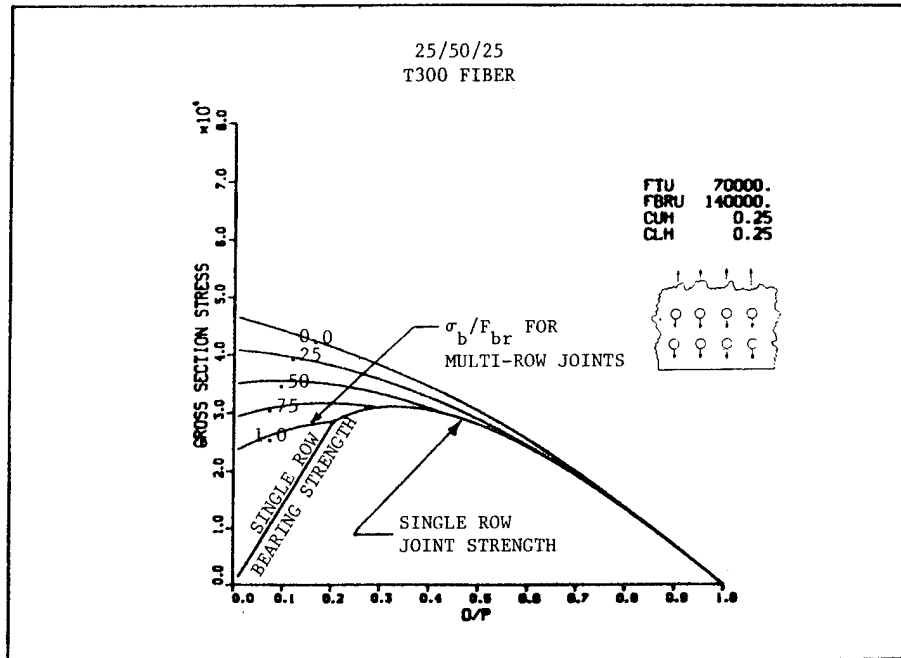

FIGURE 17 BEARING BYPASS CURVES FOR T-300 AND IM6 LAMINATES

T300 and IM6. For the single bolt case, (all bearing), the joint strengths are limited by bearing failures for all but the pseudo-isotropic T300 laminate, which still fails in net section tension. This limitation is seen especially significant for the 60/20/20 laminates where the bearing cutoff occurs at about 60 percent of the loaded hole strength for the T300 laminate and at 35 percent of the loaded hole strength for the IM6 laminate.

Potential joint strengths for single and double row joints can be seen clearly in graphs of the form of Figures 18 and 19. The values for F_{TU} , F_{BRU} , C factor unloaded hole (C_{UH}) and C factor loaded hole (C_{LH}) are based on limited test data for Figure 18(a). The values in Figure 18(b) and Figure 19(a), (b) are assumed. The lower limit line indicates the joint strength of a single row joint. The other five lines represent various ratios of the bearing stress at the critical fastener to the bearing ultimate, or in other words, various combinations of bearing and bypass stress. The curve corresponding to $\sigma_{br}/F_{bru} = 1.0$, for example, represents the case where the critical fastener is loaded to the bearing cutoff, and the bypass has been increased to the point that simultaneous bearing and net section tension failures occur (Reference Figure 17, the "knee" in the bearing/bypass curve). The other extreme, ($\sigma_{br}/F_{bru} = 0.0$), is only a theoretical maximum. Physically it represents the case where the "critical fastener" is simply an open hole, and the joint strength is the unloaded hole tension strength. Obviously placing an empty hole "in front" of a bolted joint does nothing to increase its strength, but the message is clear that it is desirable to maximize the bypass load at the first fastener.

Comparing (a) and (b) of Figure 18 reveals the expected increase in single row joint strength but little change in the optimum D/P. This is contrasted with (a) and (b) of Figure 19 which, when compared,



(a) T300 FIBER

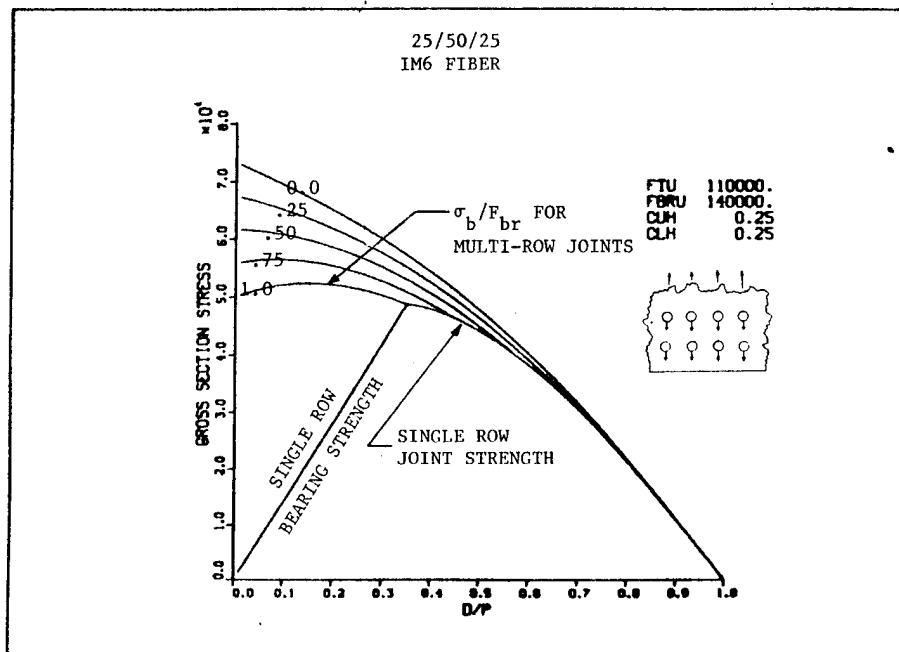

(b) IM6 FIBER

FIGURE 18 JOINT STRENGTH VERSUS BOLT SPACING
 FOR PSEUDO-ISOTROPIC LAYUP PATTERNS

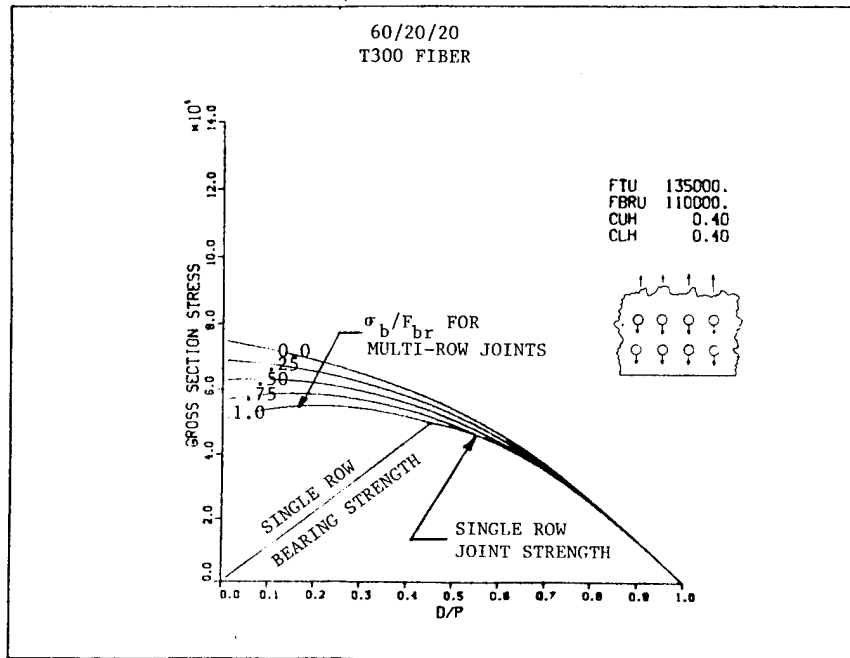

(a) T300 FIBER

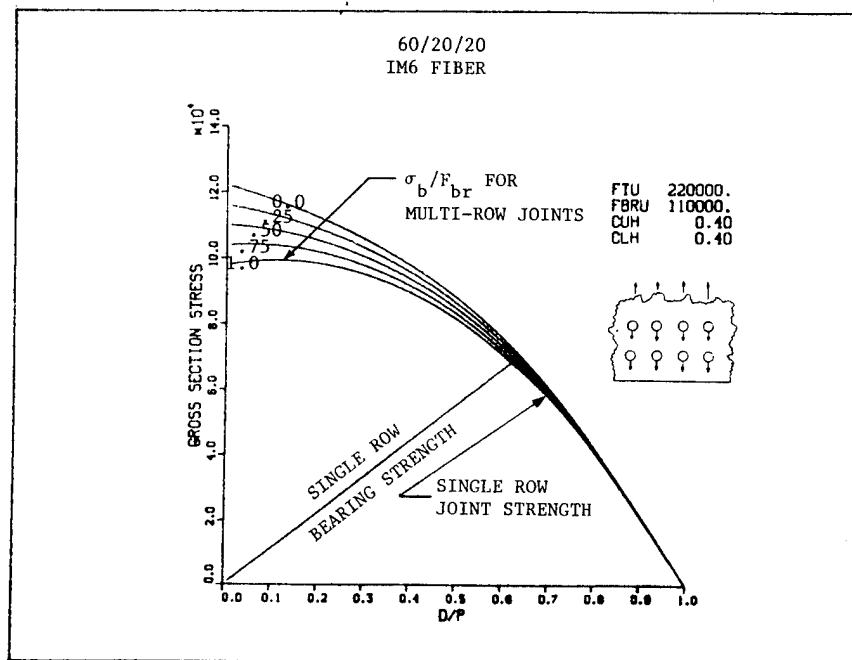

(b) IM6 FIBER

FIGURE 19 JOINT STRENGTH VERSUS BOLT SPACING
 FOR 60/20/20 LAYUP PATTERNS

reveal a significant shift in optimum D/P. This is the same effect seen in Figure 17, where the bearing strength severely limits the 60/20/20 laminate strength but has little effect on the 25/50/25 laminate. Since practical design considerations limit the D/P to .25 or less, the real effect of the increased tension strength of the IM6 laminates is to force virtually all of the single row joints to fail in bearing, rather than net section tension.

The benefits of switching to a multi-row joint, however, reveal the true value of the higher strengths of IM6 laminates. Figure 18 illustrates that the absolute maximum strength of a multi-row joint with a P/D of four is 41000 psi for T300 versus 62000 for IM6, (an increase of about 50 percent). Likewise from Figure 19, the increase is from 68000 to 108000 again in excess of 50 percent.

It should be obvious from these curves that the strength of a multi-row joint is a function of the ratio of bearing load to bypass load at the critical fastener, or in other words, of the bolt load distribution in the joint. The analysis methods mentioned above, (A4EJ and finite element modeling), which are capable of predicting this distribution, both require that the load/deflection properties or "spring rate" of the bolts be known. It has been demonstrated, (NASA contract NAS1-16857), that these load/deflection characteristics can be analytically predicted for large diameter bolts in relatively thick laminates. It remains to be shown that such good agreement exists for smaller bolts and thin laminates. The use of these thin laminates presents a more challenging problem when trying to experimentally determine the bolt spring rates. The devices used to measure the load/deflection properties of the thicker laminates are too large and cannot be modified for use with such thin laminates. Douglas has an independent program for the design and fabrication of a device which can measure the needed deflection for laminates as thin as .050 inches. This device bears some similarity to the devices used for the thicker laminates in the sense that it still uses a standard MTS clip gauge for the purpose of recording the data.

Another option being pursued makes use of a device developed by American Cyanamid for measuring load/deflection properties of adhesively bonded joints. A sample specimen has been fabricated and is to be tested using this device to determine the feasibility of its use.







EVALUATION OF PRELIMINARY TEST RESULTS

Several Group A type specimens have been fabricated from F584/AS6 material which was in house for process development purposes. Specimens were cut from panels fabricated during process development. The AS6 fiber, although less stiff, has similar strength properties to the IM6 fiber selected for use in this program. It was expected that these tests would provide some insight on the behavior of certain joint configurations. A summary of these tests is presented in Table VI.

Specimen P1 established a "worst case" bearing allowable for pseudo-isotropic laminates, being a single shear joint and using a countersunk fastener. The failure was a combination of bearing and pull-through at 2000 pounds which corresponds to a bearing stress of 117000 psi.

Specimen P2 was a pseudo-isotropic specimen designed to provide equal load sharing between the two fasteners by making the joint exactly symmetrical. Although the nature of these simple tests is such that it is improper to claim "correlation", since the purpose of the tests is to determine the basic parameters to be used in the analysis, it is interesting to compare the results of this test to the bearing/bypass curve presented in Figure 17. The curve for the 25/50/25 IM6 laminate predicts, for the equal load sharing case, a net section tension failure at $\sigma_{\text{bypass}} = \sigma_{\text{bearing}} = 28000$ psi. This corresponds to a failure load of $2 \times 28000 \times 0.91 \times 0.75 = 3822$ pounds.

TABLE VI PRELIMINARY SPECIMEN TEST RESULTS
 F584/AS6 MATERIAL

#	SPECIMEN	EXPECTED LOAD	ACTUAL LOAD	EXPECTED MODE	ACTUAL MODE
P1			2000	BEARING	BEARING/ PULL-THRU
P2		3800	3695	NET-SECTION TENSION	NET-SECTION TENSION
P3			2155	BEARING	
P4		3800	3955	NET-SECTION TENSION	NET-SECTION TENSION
P5			2425	BEARING	BEARING/ SHEAR-OUT
P6		7050	7230	BEARING	BEARING
P7			2430		NET-SECTION TENSION

Specimen P3 was an attempt to determine a "best case" bearing allowable for pseudo-isotropic laminates. This specimen was a double shear joint, which should have eliminated the eccentricity inherent in specimen P1, was not countersunk, and provided good clamp up for the middle (critical) member. The test results are doubtful, however, as there was a considerable amount of rotation observed, apparently due to differential slippage of the outer members (splice plates) in the grips. The failure mode appeared to be a tension failure, however there was evidence that a considerable amount of bearing deformation had occurred prior to failure. The failure load of 2155 pounds corresponding to a bearing stress of 126000 psi is therefore considered to be unreliable.

Specimen P4 was an attempt to determine the performance of a simple multi-row joint. Although impossible to predict the exact bolt load distribution without knowing the bolt spring rates and the elastic properties of the laminate, an A4EJ analysis using assumed values, predicted almost equal load sharing. The expected load is therefore the same as for specimen P2, (ignoring the effects of eccentricity and the possible differences in stress concentration factors and bolt flexibilities of countersunk versus protruding head fasteners). The actual failure load was, as might be expected, slightly higher than that for specimen P2, indicating that the performance of the double lap splice is indeed better, although perhaps not substantially so.

Specimen P5 is similar to specimen P3 except for the 60/20/20 laminate. The failure load of 2425 pounds corresponds to a bearing stress of 113000 psi.

Specimen P6 was a three row joint of the 60/20/20 laminate. It is interesting to examine the analysis of this joint as it relates to bearing/bypass curve of Figure 17 and the joint efficiency curve of Figure 19 (b). An A4EJ analysis of this configuration indicates that the bolt loads are initially distributed 39 percent, 30 percent and 31 percent to the "first", "second" and "third" fasteners respectively. This translates to a ratio of bearing to bypass load of .64 at the first (critical) fastener. Examining the bearing/bypass curve for this laminate reveals a bearing failure at a total gross stress, (bearing + bypass), of 70500 psi. What this analysis ignores, however, is the effect of bearing yield on the redistribution of bolt loads. Assuming the load at the first bolt remains constant at the bearing ultimate value (27500 psi), the bypass load can increase until either 1) the second and third fasteners reach bearing ultimate or, 2) the bypass load increases to the point that the "knee" in the bearing/bypass curve is reached, and the joint fails in tension through the first fastener hole. The second of these phenomenon would occur at a gross bypass stress of approximately 70000 psi yielding a total joint strength of 97500 psi which corresponds to the $\sigma_{br}/FBRU=1.0$ line at a D/P of .25 from Figure 19 (b). This failure is preceeded, however, by the second and third bolts reaching bearing ultimate, resulting in a total joint strength of $3 \times 27500 = 82500$ psi, at which time the joint simply ceases to carry any additional load. The actual failure load of 7230 pounds corresponds to a gross stress of 84600 psi, and indeed the failure mode was exactly as expected.

The test of specimen P7 was conducted to determine whether a single bolt joint in a pseudo-isotropic laminate with a W/D of 3 would fail in bearing or net section tension. Using the preliminary laminate allowable as given in Table V, and an assumed "C factor" of .25, the loaded hole strength is 2380 pounds or a

gross stress of 46500 psi. This implies that the bearing strength has to be at least $2380/ (.188 \times .091)$ or 139000 psi in order to fail the joint in net section tension. Specimen P3 had indicated that the bearing strength was lower than this, but again, the results of that test were suspect. The failure of the joint at 2430 pounds in net section tension confirmed the suspicion that the bearing allowable for the pseudo-isotropic laminate is well above 126000 psi.







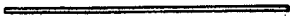

ANALYSIS OF TEST SPECIMENS

A preliminary analysis of the Group A test specimens, (excluding specimen A10), has been completed. The nature of the Group A tests is such that these "predictions" are, in essence, simply educated guesses of the parameters the tests are designed to yield. These values are useful, however, for test set-up purposes and are presented in Table VII.

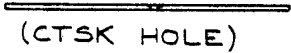
Analysis of the Group B specimens has begun. Finite element models have been completed for each of the three specimens and are shown in Figures 20, 21, and 22. The model of the shear tee pull-off specimen (Figure 20) uses bending bars to represent the stiffnesses of the skin and the shear tee. The adhesive is modeled as a series of membrane elements. Although the model may not be able to provide a quantitative estimate of the failure load, it should be adequate for comparing and evaluating design configurations. This model is in the check-out phase.

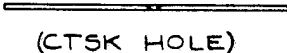
The unstiffened cutout model (Figure 21) represents the panel skin as anisotropic membrane elements. This model was used to evaluate the effects of "softening" the area around the cutout by substituting the stiffness properties of a fiberglass/carbon hybrid for those of the basic carbon skin. The results of this analysis are summarized in the discussion of cutouts on page 27.

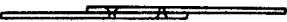
TABLE VII
 PRELIMINARY GROUP A ANALYSIS RESULTS

SPECIMEN	CONFIG. #	EXPECTED FAILURE LOAD	EXPECTED FAILURE LOAD
	A1 -501 -503 -505	6900# 7425 18400	TENSION
	A3 -501 -503 -505	3755 4410 9473	TENSION
	A4 -501 -503 -505	3651 4264 9555	NET-SECTION TENSION
 (CTSK HOLE)	A4 -507 -509 -511	3651 4264 9555	NET-SECTION TENSION
	A5 -513 -515 -517	2866 3653 7094	NET-SECTION COMPRESSION
 (CTSK HOLE)	A5 -519 -521 -523	2866 3653 7094	NET-SECTION COMPRESSION
	A6 -501 -503 -507 -509 -505 -511	1824 2426 1824 2426 2540 2540	BEARING " " " " "
	A7 -501 -503	2655 4000	TENSION BEARING
	A8 -513 -515 -517 -519 -521 -523	1616 2120 2454 1824 2432 2454	TENSION " BEARING " " "
	A9 -501 -503	37553 21519	COMPRESSION

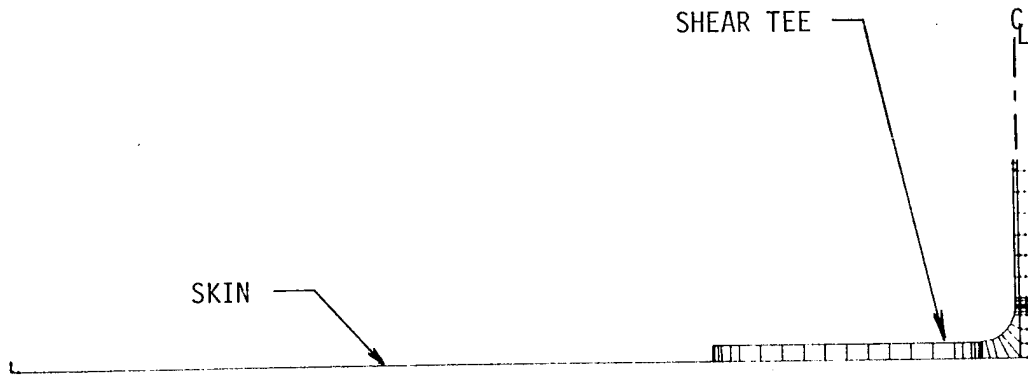

FIGURE 20 SHEAR TEE PULL-OFF MODEL

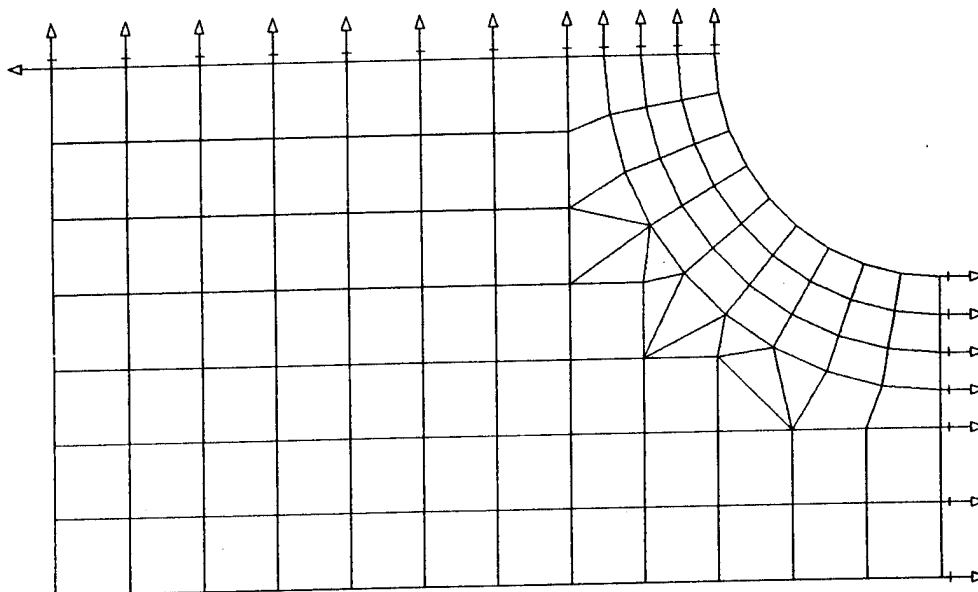

FIGURE 21 UNSTIFFENED CUTOUT MODEL

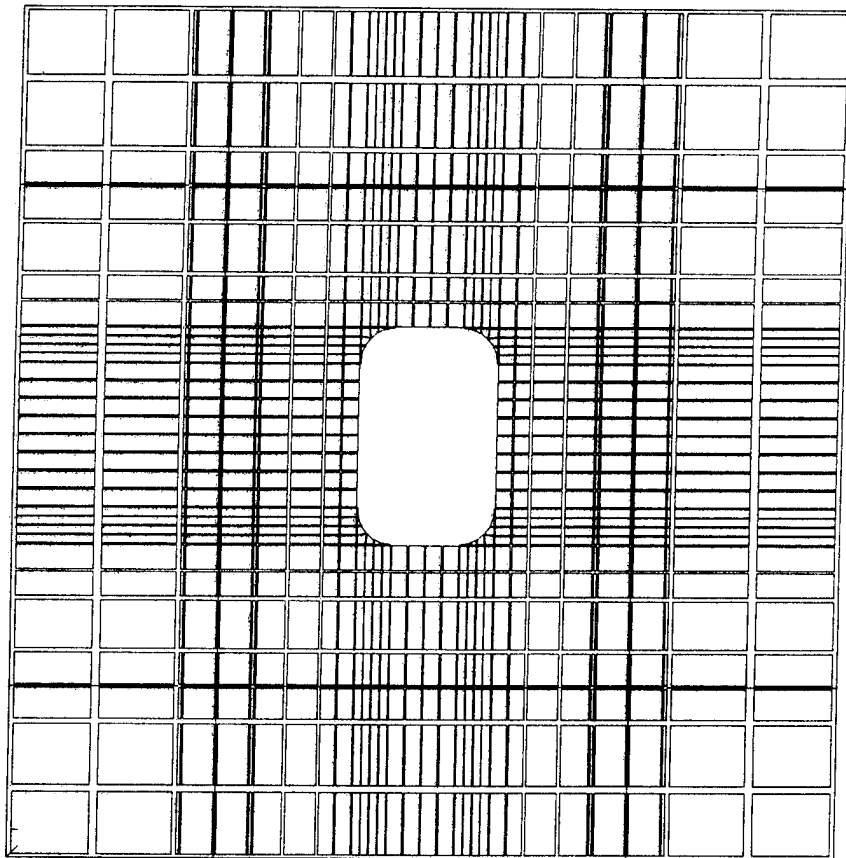

FIGURE 22 STIFFENED CUTOUT MODEL

The stiffened cutout model (Figure 22) uses anisotropic plate elements to model the basic skin as well as the skin + stiffener areas. The upstanding legs of the stiffeners are modeled as bending bars, making use of the offset capability of the NASTRAN "CBAR" element to account for the eccentricity. This model will be used for evaluating preliminary designs as well as for static, buckling and postbuckling analyses of the final design. This model is also in the check-out phase.

SECTION 4

PROCESS DEVELOPMENT AND FABRICATION

4.1 PROCESS DEVELOPMENT

A fuselage material will be exposed to paint strippers many times over its projected lifetime. The most common solvent found in these strippers is Methylene Chloride. The following test was run to anticipate possible solvent degradation problems associated with toughened composite materials. See Table VIII.

TABLE VIII
SUMMARY OF SOLVENT TESTS ON F584/AS6

SPECIMEN ID	INITIAL WEIGHT (gms)	WEIGHT AFTER 24 HRS METHYLENE CHLORIDE (gms)	% CHANGE
F584/AS6-1	.5364	.5374	+0.19
-2	.6797	.6818	+0.31
-3	.6287	.6303	+0.26
AVERAGE			+0.25

The F584 showed no significant solvent related weight gain during the 24 hour soak. Short beam shear specimens will also be run to check on any changes in mechanical strength after repeated exposure to Methylene Chloride. The solvent test is to evaluate a resin related property, i.e., the test is valid for F584/IM6.

PROCESS DEVELOPMENT PLAN PHASE I

The Process Development Plan - Phase I was completed. The plan includes processing development tests to assure the quality of the cured laminate, adhesive bonding tests to establish adequacy of the bonding process for secondarily bonded details such as the longerons, and the establishing of nondestructive inspection standards.

In addition, the plan includes the tooling approaches, material processing parameters, post-processing requirements and inspection criteria which will be employed during the program. Four subcomponents were identified as necessary elements for the eventual full-scale fuselage structure fabrication and inspection standards. (Table IX)

The design and fabrication of the frame tool has been completed. A carbon/polyacrylic frame tool aid is also complete. Three tool-proof parts have been fabricated using the frame tool & aid. These tool proofs consist of: one fiberglass frame and two AS4/3501-6 carbon/epoxy frames. The AS4/3501-6 material was used to provide an early indication of potential problems/concerns prior to receipt of the F584/IM6.

Several fabrication orders have been prepared in anticipation of the in-house arrival of F584/IM6 carbon/epoxy material. These fabrication orders have been designed to gain experience with the processing characteristics of the F584 resin system.

TABLE IX
 SUMMARY OF FABRICATION AND PROCESS VERIFICATION

SUBCOMPONENT	METHOD EVALUATION				
	C-SCAN	RESIN/VOID	PHOTO-MICRO GRAPH	MECHANICAL TEST TRAVELER	LAP SHEAR
WBS212001 Longeron	X	X	X	X	
02 Shear Tee	X	X	X	X	
03 Frame	X	X	X	X	
04 Longeron/Skin Shear Tee/Frame	*X	**X	**X	**X	X
* Resonance Impedance-Bond Line Evaluation					
** Co-Cured Evaluation					

4.2 TOOLING

The tool design of the plastic laminating mold (PLM) for the final 9 ft. x 14 ft. x 135 in. radius fuselage structure has been released. (See Figure 23) Fabrication of the PLM's egg-crate backing structure has begun. The work order (fabrication instructions) to brake form, computer-numerically-controlled machine the tool surface and weld the laminating plate to the backing structure is currently in the fabrication planning department.

The large quantity of fastener holes, hence drilling requirements, has prompted an investigation into tool wear and fabrication methodology for the fuselage program. Data has been collected for the drilling of various hole sizes using AS4/3501-6 material. (A comparable alternative to F584/IM6 prior to the latter's availability). This data has closely matched past Douglas experience in drilling carbon/epoxy materials. Results from this investigation are being used to order tools based upon hole quantities and sizes.

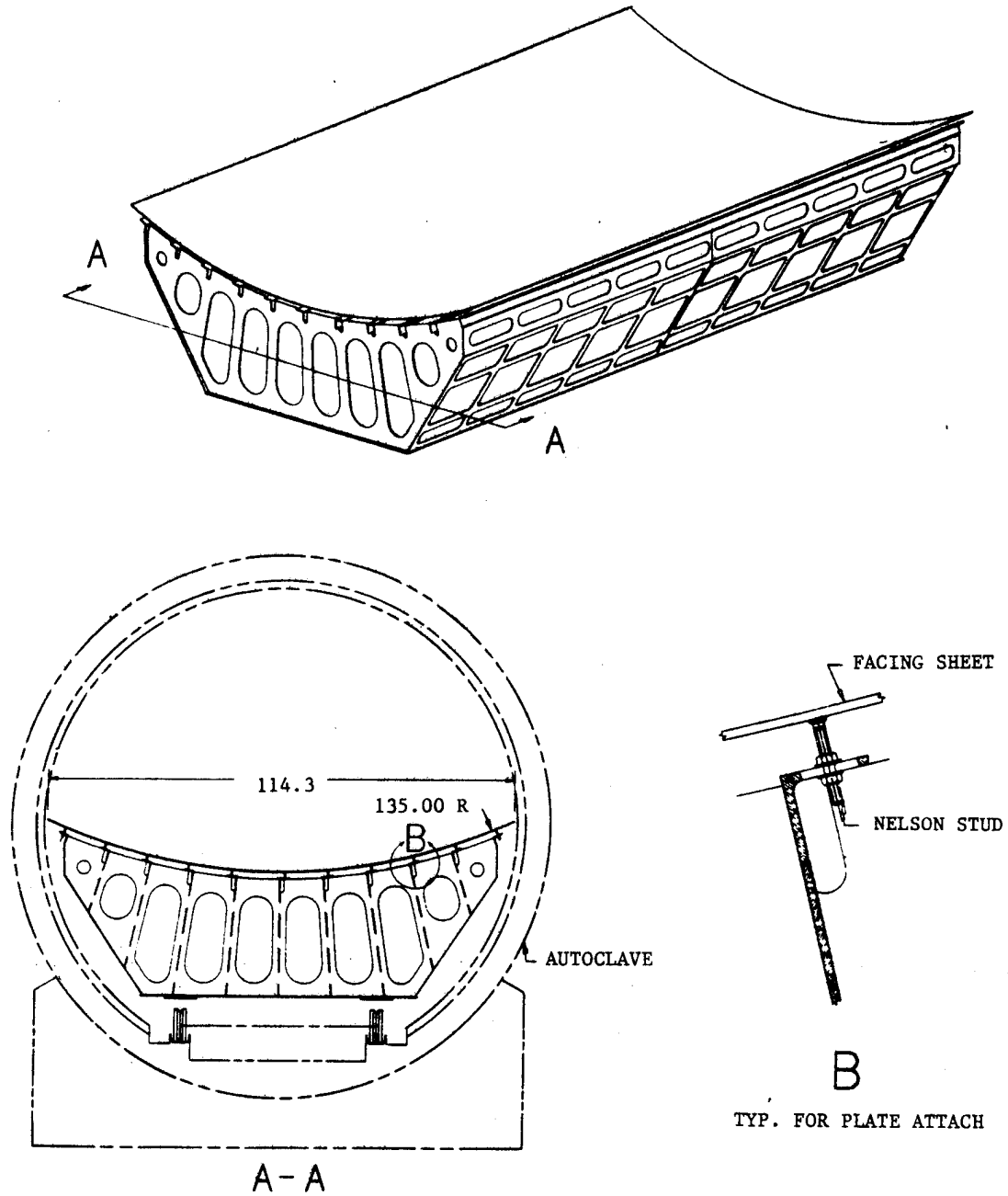

FIGURE 23 PLASTIC LAMINATING MOLD

SECTION 5

REFERENCES

1. Nelson, W.D.; Bunin, B. L.; and Hart-Smith, L. J.: Critical Joints in Large Composite Aircraft Structure. NASA CR-3710, January 1983.
2. Ogonowski, J.M.: Effect of Variances and Manufacturing Tolerances on the Design Strength and Life of Mechanically Fastened Composite Joints. AFWAL-TR-81-3041 Volume 3 - Bolted Joint Stress Field Model (BJSFM) Computer Program User's Manual, April 1981.
3. Agarwal, B.L.: Postbuckling Behavior of Composite Shear Webs. Proceedings of the AIAA/ASME/ASCE/AHS 21st Structures, Structural Dynamics and Materials Conference, Seattle, Washington, May 12-14, 1980. AIAA Paper No. 80-0869.
4. Renieri, M.P. and Garrett, R.A.: Postbuckling Fatigue Behavior of Flat Stiffened Graphite/Epoxy Panels under Shear Loading. NADC-81168-60, July 1982.

DOUGLAS AIRCRAFT COMPANY

3855 Lakewood Boulevard, Long Beach, California 90846 (213) 593-5511

