

ADD420803

NASA TECHNICAL NOTE



NASA TN D-8174

NASA TN D-8174

RESTRICTION STATEMENT A
Approved for public release;
Distribution Unlimited

DEPARTMENT OF DEFENSE
PLASTICS TECHNICAL EVALUATION CENTER
PICATINNY ARSENAL, DOVER, N. J.

SIMULATED STUDIES OF WEAR AND FRICTION
IN TOTAL HIP PROSTHESIS COMPONENTS WITH
VARIOUS BALL SIZES AND SURFACE FINISHES

Max A. Swikert and Robert L. Johnson
Lewis Research Center
Cleveland, Ohio 44135

19960313 123

PLASTEC
23504



NATIONAL AERONAUTICS AND SPACE ADMINISTRATION • WASHINGTON, D. C. • MARCH 1976

DTIC QUALITY INSPECTED 1

1. Report No. NASA TN D-8174	2. Government Accession No.	3. Recipient's Catalog No.	
4. Title and Subtitle SIMULATED STUDIES OF WEAR AND FRICTION IN TOTAL HIP PROSTHESIS COMPONENTS WITH VARIOUS BALL SIZES AND SURFACE FINISHES		5. Report Date March 1976	6. Performing Organization Code
		8. Performing Organization Report No. E-8528	
7. Author(s) Max A. Swikert and Robert L. Johnson		10. Work Unit No. 506-16	11. Contract or Grant No.
9. Performing Organization Name and Address Lewis Research Center National Aeronautics and Space Administration Cleveland, Ohio 44135		13. Type of Report and Period Covered Technical Note	
		14. Sponsoring Agency Code	
12. Sponsoring Agency Name and Address National Aeronautics and Space Administration Washington, D. C. 20546		15. Supplementary Notes	
16. Abstract <p>Experiments were conducted on a newly designed total hip joint simulator. The apparatus closely simulates the complex motions and loads of the human hip in normal walking. The wear and friction of presently used appliance configurations and materials were determined. A surface treatment of the metal femoral ball specimens was applied to influence wear. The results of the investigation indicate that wear can be reduced by mechanical treatment of metal femoral ball surfaces. A metallographic examination and surface roughness measurements were made.</p>			
17. Key Words (Suggested by Author(s)) Hip joint Wear Prosthetics Surface topography Friction Surface finish		18. Distribution Statement Unclassified - unlimited STAR Category 37	
19. Security Classif. (of this report) Unclassified	20. Security Classif. (of this page) Unclassified	21. No. of Pages 26	22. Price* \$3.75

* For sale by the National Technical Information Service, Springfield, Virginia 22161

DISCLAIMER NOTICE



THIS DOCUMENT IS BEST QUALITY AVAILABLE. THE COPY FURNISHED TO DTIC CONTAINED A SIGNIFICANT NUMBER OF PAGES WHICH DO NOT REPRODUCE LEGIBLY.

SIMULATED STUDIES OF WEAR AND FRICTION IN TOTAL
HIP PROSTHESIS COMPONENTS WITH VARIOUS
BALL SIZES AND SURFACE FINISHES

by Max A. Swikert and Robert L. Johnson

Lewis Research Center

SUMMARY

An investigation was conducted on a newly designed total hip simulator to evaluate the apparatus and at the same time investigate mechanical treatment of metal femoral ball surfaces to extend the wear life of presently used ultrahigh molecular weight, polyethylene (UHMWPE) acetabular cup and cobalt-chromium alloy femoral ball combinations. The effects of femoral ball and acetabular cup size were also investigated. The surfaces of the femoral balls were treated by blasting the surfaces with different sizes and geometry of grits, which were propelled through a nozzle by compressed air or an air-water mixture.

The results of the study showed that the simulator is capable of providing the complex motions and loads of human walking. The wear life of presently used hip joint appliances can be extended by blasting the surface of the metal femoral ball with a 2-micrometer aluminum oxide powder and air-water mixture. The ball-cup size is a consideration in wear life. The coefficient of friction for UHMWPE cup and cobalt-chromium alloy compares favorably with those of other investigators.

INTRODUCTION

In the last two decades the surgical replacement of diseased, damaged, and worn-out body joints has become increasingly successful. Special surgical grade prostheses materials (i. e., silicones and UHMWPE (ultrahigh molecular weight polyethylene) polymers (refs. 1 and 2)) have been critical to the achievements. The most important factor in the use of foreign materials is tissue compatibility or body acceptance of that material. Of equal importance, the material must have suitable mechanical strength and good friction and wear properties.

The hip joint is one of the more troublesome to man and has received much attention

by orthopedists. A number of artificial total hip joints have been designed and used with varied success (refs. 3 to 6). Failures may result in immobilization of the patient. In essence, the patients have been evaluating experimental artificial joints (ref. 7). It is important, then, that materials and prosthetic devices be designed and evaluated with mechanical simulators so that risks to patients are reduced to the absolute minimum.

Laboratory devices used for investigating prosthetic appliances have had serious limitations: They are either large, complex devices with operational problems that have discouraged use or are simple devices that do not simulate conditions. Many of the problems with prostheses that have been revealed in patients could have been eliminated by prior evaluation in an effective total hip simulator. A new device with a readily varied operation cycle has been designed that can simulate complex motions and loads.

Friction and wear are important in the artificial hip joint. The friction must be low enough to permit the body muscles to move the femoral ball in the acetabular cup with reasonable effort. The wear of the femoral ball and acetabular cup contact interface must be minimized for maximum appliance life. Also, with lower wear of the femoral ball and acetabular cup the less wear debris the body must tolerate.

The most commonly used total hip joint prosthetic devices today are constructed of a cobalt-chromium alloy or stainless steel femoral ball with an UHMWPE acetabular cup. This combination has been used successfully for 10 years, but its useful life has not been adequately documented. Furthermore, in Europe (ref. 8) a number of appliances failed by stem fracture in patients - a problem that could certainly have been prevented with an effective total hip simulator.

The lubrication mechanism for polymers sliding against metals depends on a thin film of the polymer to transfer to the metal; thus, the real sliding materials are polymers sliding against polymers (refs. 9 to 11). The thin transfer film must adhere to the metal to provide minimum wear. Mechanical bonding of the polymer to the metal surface is important. The objectives of this investigation are to (1) introduce a unique newly designed total hip simulator, (2) demonstrate the influence of surface texture and roughness of the cobalt-chromium alloy femoral component balls on the wear of surgical grade, UHMWPE acetabular cups, and (3) illustrate the influence of several femoral ball diameters on wear and friction of typical total hip prosthesis configurations.

APPARATUS

The total hip simulator (figs. 1(a) and (b)) is designed to accept various designs of full-size total hip prostheses or a ball and socket test specimen and to simulate the motions (ref. 12) and variable loads (refs. 12 to 14) encountered in walking or any exercise motion of the hip joint (fig. 2).

The femoral ball is mounted in a fixture extending from the end of an oscillating shaft (fig. 1(a)). The shaft oscillates up to $\pm 20^{\circ}$ and simulates the major extension and flexion of the hip joint in the sagittal plane of walking (ref. 12). The shaft (fig. 1(b)) is driven by a variable speed dc electric motor and worm gear box in unidirectional rotation. An eccentric is mounted on the output shaft of the gearbox and is adjustable to give the desired extension and flexion motion of the prosthetic device. An adjustable length crank arm is connected on one end to the gearbox eccentric and allows positioning of the ball in the sagittal plane. The other end of the crank arm is connected to a larger eccentric on the simulator drive shaft and drives the main shaft in oscillating motion. The femoral ball (fig. 1(a)) is mounted on a bearing assembly in the femoral ball fixture perpendicular to the drive shaft. The inner bearing assembly holds the femoral ball. It has an arm extending radially from its center. The radial arm is restrained at the extended end and thus as the drive shaft oscillates the femoral ball will oscillate in the transverse plane. For normal walking this oscillation is $\pm 7^{\circ}$ (ref. 12). The amount of internal and external rotation is determined by the restraining location on the radial arm.

The acetabular cup (fig. 1(a)) is mounted in a fixture that is stabilized with flexures. These flexures carry the load applied to the prosthesis assembly and permit the acetabular cup to move in a third motion $\pm 6^{\circ}$ (ref. 12) and simulate abduction and adduction motion of walking as encountered in the frontal plane. That simulated motion is a plane through the main drive shaft centerline. The motion (figs. 1(a) and (b)) is transmitted with a push rod driven by a cam on the main drive shaft. The cam is designed for the desired motion of the acetabular cup.

The acetabular cup fixture has a special flexure suspension and force transducer that enables measuring the friction force in the sagittal plane (fig. 1(a)).

The load is applied by means of a hydraulic cylinder and a hydraulic pump system through cables and main flexures. A block schematic of the mechanical, hydraulic, and electrical system is shown in figure 3. The hydraulic cylinder is controlled by a hydraulic servosystem and electronic programmer. A strain gage type load cell with two strain gage bridges is connected mechanically to the hydraulic cylinder. One of the bridge circuits serves as an electrical feedback to the hydraulic servovalve and servo-controller amplifier. The second strain gage bridge is used to measure the load. The load strain gage bridge output is recorded on a strip chart recorder as well as being fed into an analog device along with the friction force transducer output which computes the instantaneous coefficient of friction. The load program desired is plotted on an aluminumized mylar graph and is mounted on a rotating drum. A capacitance probe follows the chart plotted and actuates the hydraulic servosystem. The rotating drum is mechanically connected and synchronized with the oscillating drive shaft. An elastomer bellows encapsulates the ball and socket to retain a desired fluid for lubrication. A fluid can be pumped into the prosthesis cavity with a tubing pump. The main components of the ap-

paratus are housed in a chamber to control the atmosphere surrounding the prosthesis.

SPECIMEN PREPARATION AND PROCEDURE

The alloy composition of the femoral ball specimens was 57.3 percent cobalt, 30 percent chromium, 7 percent molybdenum, 2.5 percent nickel, 1 percent manganese, 1 percent silicon, 0.8 percent iron, and 0.4 percent carbon. The specimens were ground and polished to surgical implant standards. Four surface treatments were applied to obtain four different surface textures (see table I). The liquid hone, fine grit blast, glass bead blast, and sand blast treatments are described in appendix A. All surfaces were polished to original optical-like finish before applying surface treatments to produce the desired topography (table I).

The ball was refinished on a metallographic polishing wheel with a flannel cloth supported on a 5.08-centimeter- (2-in. -) thick polyurethane sponge. Aluminum oxide powder and water were used as a polishing agent. The polyurethane sponge allowed the flannel to conform to the ball surface to provide uniform polishing when the polishing wheel was rotated. After final polishing the ball specimens were rinsed in tap water. The specimens were then finished by one of the four surface treatments. Following the surface treatments, the specimens were rinsed with tap water and then with distilled water. The ball specimen was then suspended in a beaker of distilled water and placed in an ultrasonic cleaner for 1 hour to remove any loose particles from the surface of the ball.

The acetabular cup specimens were commercially molded ultrahigh molecular weight polyethylene (UHMWPE) for the 22-, 28-, and 32-millimeter inside diameter sizes. The 41-millimeter inside diameter size was machined from molded blocks of UHMWPE using standard machining procedure on the outside diameter and rough machining the inside diameter. The inside diameter was finish ground with liquid nitrogen as a coolant. This minimized charging the grinding wheel with polymer and improved the surface finish of the sliding contact area of the cup. The specimens were scrubbed with a laboratory biodegradable detergent and water and finally rinsed with distilled water and placed in a desiccator.

PROCEDURE

The specimens were assembled on the apparatus and the experiment was run dry for 8 hours at a programmed load simulating walking (ref. 12). The load on the specimen ranged from 48 to 102 kilograms. A walking gait of 30 steps per minute was used in these experiments. Friction data were obtained at 1-hour intervals. Wear was deter-

mined by measuring the weight loss on the acetabular cup before and after the experiment.

Surface finish and surface profile measurements were made with a rotary talysurf for each type of ball surface treatment. The ball specimen with polished surfaces was examined by multiple beam interferometry for surface imperfections. Photomicrographs were taken of all specimens after each experiment.

RESULTS AND DISCUSSION

Several surgeons have indicated that in hip joint prostheses removed from patients it is not uncommon for the joint to be dry with no evidence of lubrication by the synovial fluid. It is essential then that self-lubricating materials be incorporated in prosthetic devices. UHMWPE can be self-lubricating in sliding contact with metal surfaces. The self-lubricating mechanism is one of transferring a layer of the UHMWPE from the acetabular cup to the ball surface, thus providing a condition of UHMWPE sliding against UHMWPE. To minimize the wear of the UHMWPE cup, it is considered essential that the transferred UHMWPE adhere to the metal cup.

Surface Topography

To determine the optimum surface topography, one must use more than standard surface roughness measurements. Topography components include (a) texture, (b) waviness, (c) roughness, and (d) shape of asperities. The standard stylus profile measuring device can show the same surface roughness for surfaces prepared by different techniques and have completely different surface geometries. For these experiments a blasting technique was used to provide a nondirectional surface geometry and different surface roughnesses. The nondirectional surface finish allows the complex relative motions of the femoral ball and acetabular cup to generate its own wear pattern. Surface roughness for the femoral ball specimens used is shown in table I. The surface profile data are presented in figures 4 and 5. Figure 4 shows interferometry photomicrographs and surface profile traces of a new femoral ball as received from the manufacturer and a femoral ball repolished after an experiment. The repolished surface was smoother than a femoral ball as received from the manufacturer. RMS surface finish measurements are not considered accurate with highly smooth polished surfaces and are therefore not reported.

Surface profile traces for the liquid hone, fine grit, glass bead, and sand blasted surfaces are shown in figure 5. The figure shows that the peak and valley heights were different for each surface treatment. In addition, the glass bead blasted and liquid

honed surfaces had rounder and wider peaks and valleys. This is attributed to the solids used in the blasting treatments. Figure 6 shows scanning electron micrographs of the solids. When these solids impinge against the surface of metals, the surface topography takes somewhat the shape of the solid or makes a replica of the surface on the metal. Controlled textured surfaces are achieved by carefully controlling the blasting procedure. Details of the surface treatments used on the femoral ball specimen are described in appendix A.

Wear

Previously reported preliminary experiments (ref. 15) using a simple disk and shoe specimen sliding in oscillating motion are shown in figure 7. These data show wear between the UHMWPE shoe and metal disks with different surface roughnesses obtained by standard commercial machine shop practices. The geometry of the surfaces was different for each metal disk. The experiments showed that a standard finish grind with a 0.37 micrometer rms had the lowest wear. Details of these experiments are presented in appendix B. Those results led to the present investigation to improve the surface geometry control and to use ball and cup configurations.

In this investigation the wear for the different surface treatments on the ball for four sizes of ball specimens is shown in figure 8. The trend was the same for all sizes of ball specimens used. The optimum surface finish trend for all sizes of ball specimens compares favorably with earlier preliminary results (fig. 7). The optimum surface finish value was 0.11 micrometer rms (liquid honed surface, table I) compared to 0.37 micrometer rms from the preliminary studies (ref. 15). The lowest wear was for the liquid honed treatment followed by the glass bead blasting, fine grit blasting, and sand blasting treatments. The wear as shown in figure 8 for a given size ball specimen does not increase with increased surface roughness (table I) as might be expected. The glass bead blasted surface was three times the roughness of the fine grit blasted surface. This shows that metal surfaces with rounded peaks and valleys provide improved wear over surfaces with sharp peaks and valleys. The new and repolished ball specimens were used as control specimens. The repolished 41-millimeter ball specimen was polished to a smoother surface than the other repolished specimens and the wear was five times higher.

Figure 9(a) provides photomicrographs of the surface of a polished ball showing the UHMWPE lodged around a scratch on the ball surface. Figure 9(b) is the same surface with the UHMWPE removed. The liquid honed surface (fig. 10) shows better UHMWPE transfer than the polished surface. The UHMWPE transfer on the glass bead blasted surface was similar to that on the liquid honed surface; in addition, the glass bead surface showed evidence of microscopic molten UHMWPE. For the fine grit blasted surface

and sand blasted surfaces the wear was different. The fine grit blasted surface showed loose wear particles and melted UHMWPE on the surface of the ball. The shear of small junctions of UHMWPE at the sliding contact area causes high surface temperatures (ref. 16). The low thermal conductivity of the polymer transfer film can provide a thermal barrier between the metal femoral ball and the UHMWPE cup. Some thermal decomposition of the UHMWPE to carbon was observed on the surface of the cup (fig. 11). As might be expected, the sand blasted ball surface showed more wear debris than the fine grit blasted surface. This rough sharp surface peeled off ribbons of UHMWPE. A typical example is shown in figure 12. Thermal decomposition of the UHMWPE to carbon was observed on the cup after running with the sand blasted ball specimen.

Figure 13 shows the same data as those shown in figure 8. This figure shows that for any given surface topography the wear weight loss increased with the increase in the ball cup diameter. Wear depth was calculated from weight loss, acetabular cup surface area, and density of UHMWPE. Figure 14 shows that the wear rate (in terms of depth) is constant for any given surface topography, is independent of the femoral ball diameter, and correlates with earlier work using a pin or disk apparatus and different materials (ref. 17). The data show that the ball cup diameter is important in determining the wear of UHMWPE acetabular cup and metal femoral ball. Data are needed on the maximum wear debris the body will tolerate, accumulative effects of wear debris, wear particle size, wear particle abrasive effects, and additional data on loads and stresses on the femoral ball for determining the best ball cup size.

Friction

The friction between the femoral ball specimen and the acetabular cup was measured in the sagittal plane. A typical coefficient of friction cycle for walking is shown in figure 15 along with the load cycle. The coefficient of friction varied from approaching zero to some maximum value for each half cycle. The peak values were not the same for both halves of the cycle. The peak values used for comparison in these experiments were peak values when the load cycle was most constant. The sinusoidal sliding velocities and the complex motions and loads can account for differences in peak values of coefficient of friction in the two halves of the cycle. Figure 16 shows the coefficient of friction for different ball cup diameters for different surface treatments. The coefficients of friction for the 28-, 32-, and 41-millimeter-diameter ball cup sizes are torque arm corrected to the equivalent 22-millimeter-diameter ball cup size. Figure 16 shows that the coefficient of friction does not change with ball cup diameter for any one surface treatment. Figure 17 shows the constant coefficient of friction value curves from figure 16 plotted against surface roughness. The coefficient of friction was 0.17 for the new and liquid honed surfaces. The fine grit blast, glass bead blast, and sand blast

coefficients of friction were 0.16, 0.15, and 0.12, respectively. These values are within a reasonable range for such materials. The decreasing trend in coefficient of friction with increasing surface roughness may be indicative of melting, thermal decomposition, and shear of the UHMWPE at the sliding interface.

SUMMARY OF RESULTS

The motions and loads on the human hip joint are complex. A newly designed simulator can provide reliable and useful data. The following results were obtained:

1. Control of surface texture of the femoral ball is important when run against a UHMWPE acetabular cup. Wear was reduced by texturing highly polished femoral ball surfaces. The lowest wear was obtained with a liquid hone texturing treatment. Textured surfaces using rounded grits had lower wear than those textured with sharp fragmented grits. For any given textured surface, the wear weight loss increased with increased femoral ball diameter, and the wear depth was constant.

2. The coefficient of friction was constant for different femoral ball sizes with any given surface treatment. The coefficient of friction was 0.17 for new and liquid honed surface treatment. The friction decreased from 0.15 to 0.12 with an increase in surface roughness. These are reasonable values for use in prosthetic devices.

3. The simulator is capable of providing the complex motions and loads of human walking. The operational cycle can be conveniently varied. The data from this device are applicable to problems for developing hip prostheses.

Lewis Research Center,
National Aeronautics and Space Administration,
Cleveland, Ohio, November 11, 1975,
506-16.

APPENDIX A

FEMORAL BALL SURFACE TREATMENTS

The blasting equipment used to apply the different finishes to the femoral ball specimens was standard industrial equipment in which a grit is propelled through a nozzle by compressed air or an air-water mixture. Different equipment was used for each finish.

The liquid hone treatment used 2-micrometer Al_2O_3 powder in a water-air mixture at a 6.9×10^5 newton per square meter pressure in a recirculating system. A SEM photomicrograph of the powder is shown in figure 6(a). The surface of a metal is shown in figure 18(a). This treatment produces a satin matte finish on the femoral ball.

The fine grit blasted surface finish used 50 micrometers of Al_2O_3 sprayed with dry nitrogen (compressed air not available) at a 5.5×10^5 newton per square meter pressure. This system was nonrecirculating. The SEM photomicrographs show the sharp cutting edges of the powder (fig. 6(b)). Figure 18(b) shows the metal surface.

The glass bead blasted surface finish used glass beads ranging from 60 to 100 micrometers, and air was at a 8.6×10^5 newton per square meter pressure. This system, which was recirculating, was designed to remove broken glass beads. The efficiency of the system to remove the broken glass beads was poor, however, as broken beads were found in the recirculating system. SEM photomicrographs of the glass beads and surface finish it produces on the metal are shown in figures 6(c) and 18(c).

The sand blasted surface finish used 200 micrometers of silica sand and air was at a 8.6×10^5 newton per square meter pressure. The system was not designed as a recirculating system, but it was known that used sand had been mixed with new sand and re-used. A typical SEM photomicrograph of the sand is shown in figure 6(d). The particles have sharp surfaces and cracks showing that the particles can shatter on impact and can produce a sharp rough surface on metal as shown in figure 18(d).

APPENDIX B

PRELIMINARY DISK AND SHOE EXPERIMENTS

In these experiments the specimen configuration was a 4.44-millimeter-diameter disk with a conforming 120° shoe segment. Both specimens were 12.7 millimeters wide. The specimens were designed to represent the cross section of a femoral ball and acetabular cup. The disk and shoe configuration and the apparatus are described in reference 18. The shoe specimen was loaded against the disk at a constant load of 47 kilograms, and the disk oscillated 20° at 58 cycles per minute for 66 hours.

In these experiments different surface finishes were applied to the disks by commercial vendors: an electrolytic grind, bead blast, machine grind, superfinish, cross-hatch hone, silicone carbide lap, polishing with polishing paper on a lathe, and diamond polish. Table II shows the surface finish for each finishing procedure. The wear was measured by measuring the displacement of the shoe against the disk during the experiment.

REFERENCES

1. Beutler, H.; and Lehmann, M.: Wear Behavior of Medical Engineering Materials. Sulzer Technical Review, no. 1974, 1974, pp. 32-38.
2. Muir, W. M.; and Martin, A. M.: Materials in Medicine. Physics Bulletin, June 1972, pp. 333-339.
3. McKee, G. K.; and Farrar, J. W.: Replacement of Arthritic Hips by the McKee-Farrar Prosthesis. J. Bone & Joint Surgery (British), vol. 48B, May 1966, pp. 245-259.
4. Lippmann, R. K.: Transfixion Hip Prosthesis. J. Bone & Joint Surgery, vol. 49A, no. 5, July 1967, pp. 876-890.
5. Ring, P. A.: Complete Replacement Arthroplasty of the Hip by the Ring Prosthesis. J. Bone & Joint Surgery (British), vol. 50B, no. 4, Nov. 1968, pp. 720-731.
6. Haywood-Wattington, M. B.: Use of the Austin Moor Prosthesis for Advanced Osteoarthritis of the Hip. J. Bone & Joint Surgery (British), vol. 48B, May 1966, pp. 236-244.
7. Charnley, J.; and Kamanger, A.: The Optimum Size of Prosthetic Heads in Relation to the Wear of Plastic Sockets in Total Replacement of the Hip. Medical and Biological Engr., vol. 17, 1969, pp. 31-39.
8. Ungethum, M.: Current State of Bio-tribology on Artificial Knee and Hip Joints. Presented at Fourth Meeting of the International Research Group on Wear of Engineering Materials, Oct. 1974.
9. Bowers, R. C.; Clinton, W. C.; and Zisman, W. A.: Frictional Behavior of Polyethylene, Polytetrafluorethylene and Halogenated Derivatives. Lubri. Eng., vol. 9, no. 4, Aug. 1953, pp. 204-208, 218-219.
10. Pepper, Stephen V.: Auger Analysis of Films Formed on Metals in Sliding Contact With Halogenated Polymers. J. Applied Phys., vol. 45, no. 7, July 1974, pp. 2947-2956.
11. Pooley, Christine M.; and Tabor, D.: Friction and Molecular Structure: The Behaviour of Some Thermoplastics. Proc. Royal Soc. (London), vol. 329A, no. 1578, Aug. 1972, pp. 251-274.
12. Duff-Barclay, I.; and Spillman, D. T.: Total Human Hip Joint Prostheses - A Laboratory Study of Friction and Wear. Instn. Mech. Engrs. Proc., vol. 181, pt. 3J, 1966-67, pp. 90-103.

13. Rydell, Nils W.: Forces Acting on the Femoral Head Prosthesis. A Study of Strain Gauge Supplied Prostheses in Living Persons. Thesis, Univ. Gothenburg, 1966.
14. Paul, J. P.: Forces Transmitted by Joints in Human Body. Instn. Mech. Engrs. Proc., vol. 181, pt. 3J, 1966-67, pp. 8-15.
15. Buckley, Donald H.: Introductory Remarks. Advances in Polymer Friction and Wear, Lieng-Huang Lee, ed., vol. 5-B, Plenum Press, 1975, pp. 601-603.
16. Swikert, Max A.; and Johnson, Robert L.: Surface Characteristics of Used Hip Prostheses. NASA TN D-6153, 1971.
17. Johnson, Robert L.; Swikert, Max A.; and Bailey, John M.: Wear of Typical Carbon-Base Sliding Seal Materials at Temperatures to 700^o F. NACA TN 3595, 1956.
18. Johnson, Robert L.; and Swikert, Max A.: Friction and Wear of Cobalt-Molybdenum and Cobalt-Molybdenum Chromium Alloy for Prosthetics. NASA TN D-6512, 1971.

TABLE I. - CHEMICAL AND PHYSICAL FINAL PROCESSING DATA
OF FEMORAL BALL SPECIMEN

Process	Surface finish ^a , $\mu\text{m rms}$	Grit		Grit carrier	Nozzle pressure, N/m^2
		Material	Size ^b , μm		
None	0.06	-----	---	-----	-----
Liquid hone	.11	Al_2O_3	2	Air and H_2O	6.9×10^5
Fine grit blast	.31	Al_2O_3	50	N_2	5.5
Glass bead blast	.93	Silica glass	80	Air	8.6
Sand blast	1.38	Silica glass	200	Air	8.6

^aMeasured with Talysurf.

^bMeasured with image analysis system.

TABLE II. - DISK SURFACE FINISH

Surface finishing method	Surface finish	
	$\mu\text{m rms}$	$\mu\text{in. rms}$
Electrolytic grind	1.69	66.6
Bead blast	.97	37.5
Machine grind	.37	14.5
Superfinish	.08	3.2
Crosshatch hone	.06	2.2
Silicon carbide lap	.31	12.2
Dry iron oxide paper polish	.06	2.2
Diamond paste polish	.06	2.2

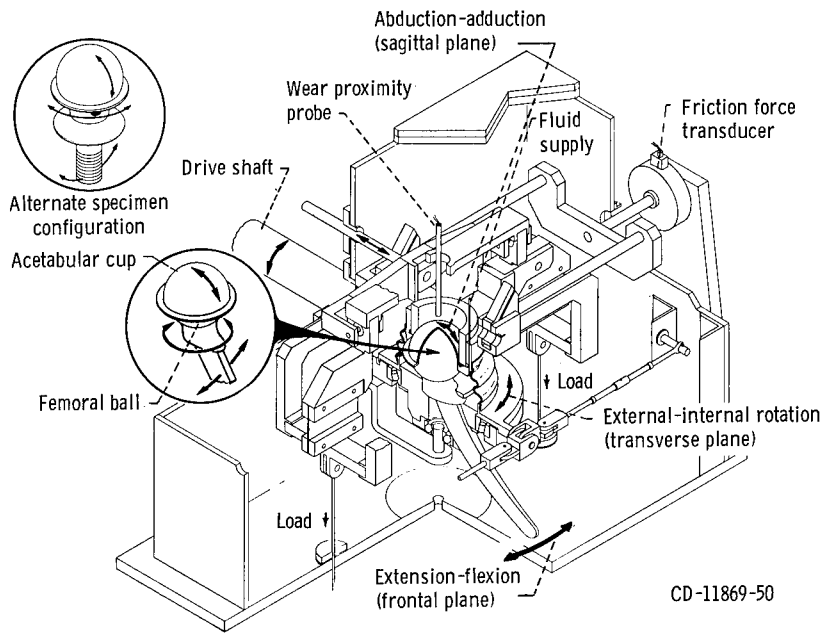

(a) Total hip simulator.

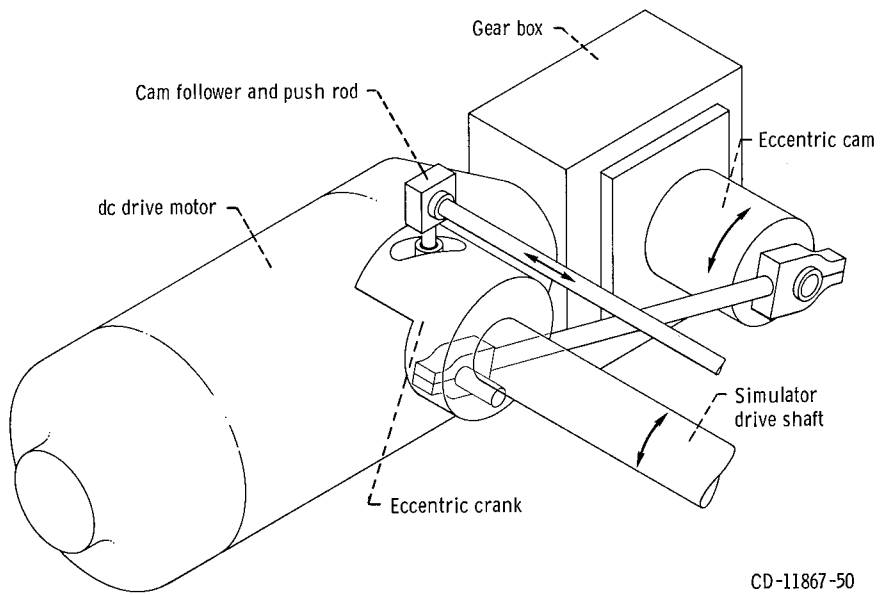

(b) Drive System.

Figure 1. - Schematic of full prosthesis hip joint apparatus.

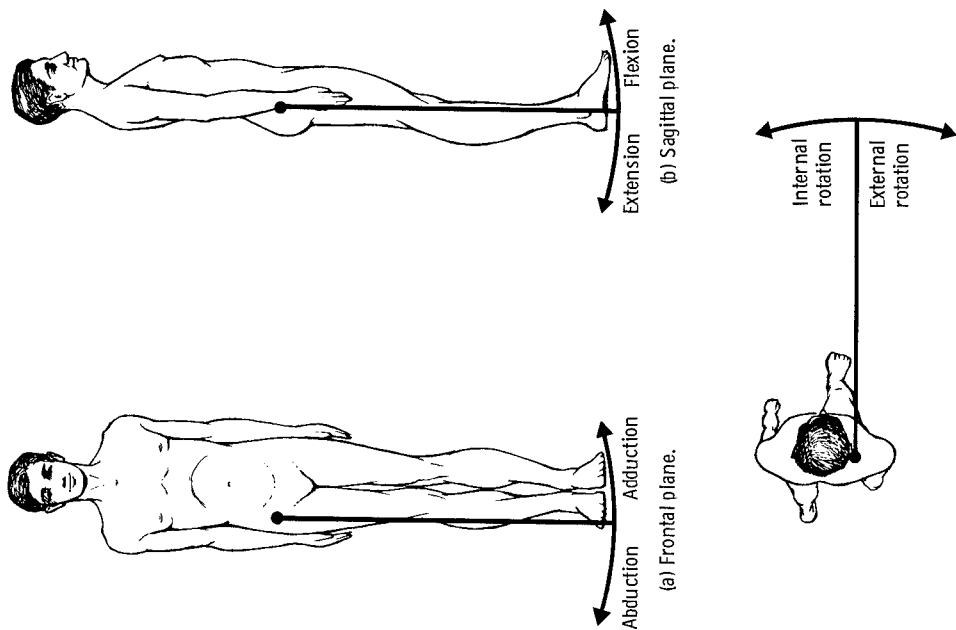

Figure 2. - Planes and motions of the hip joint (ref. 12).

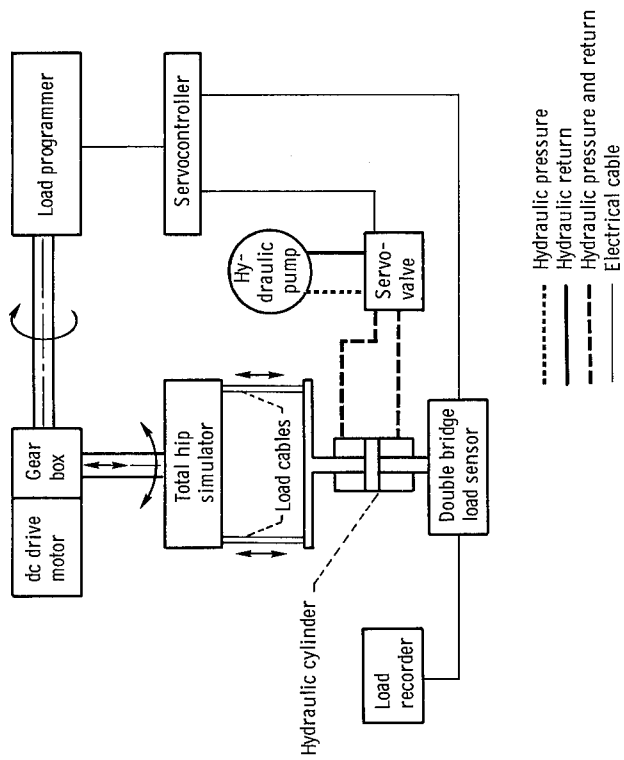
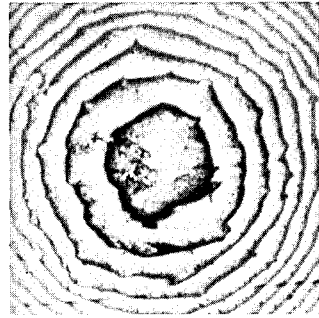
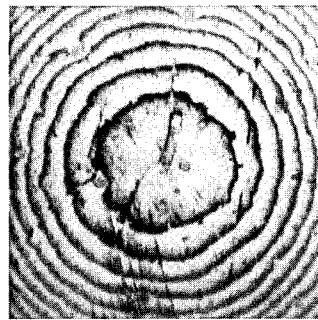
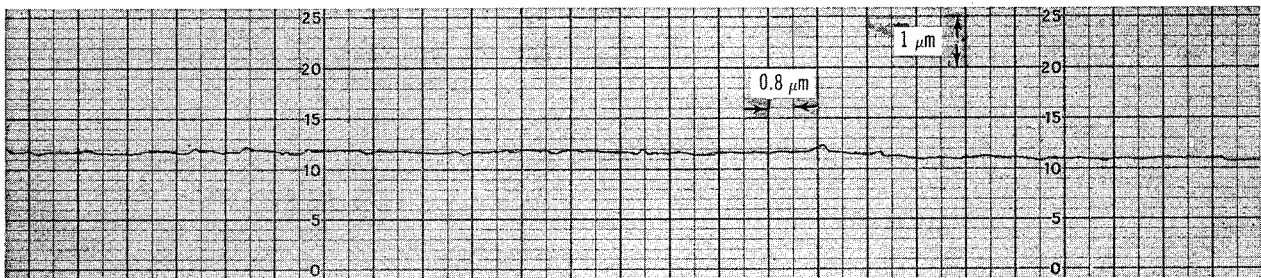

Figure 3. - Block schematic showing mechanical, hydraulic, and electrical system of total hip simulator.



New surface



Repolished surface

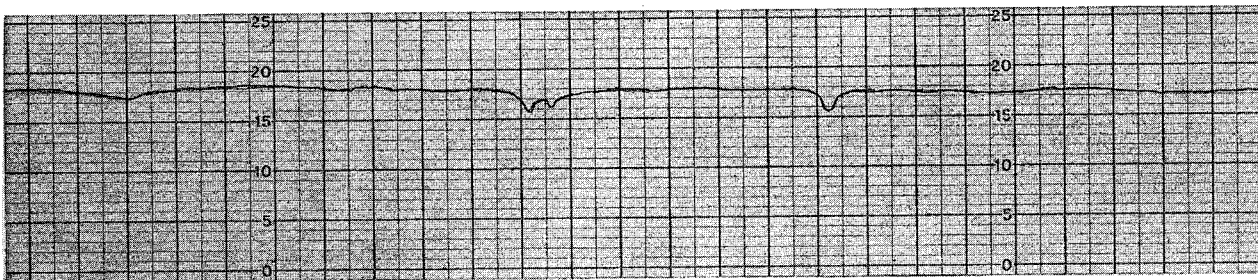
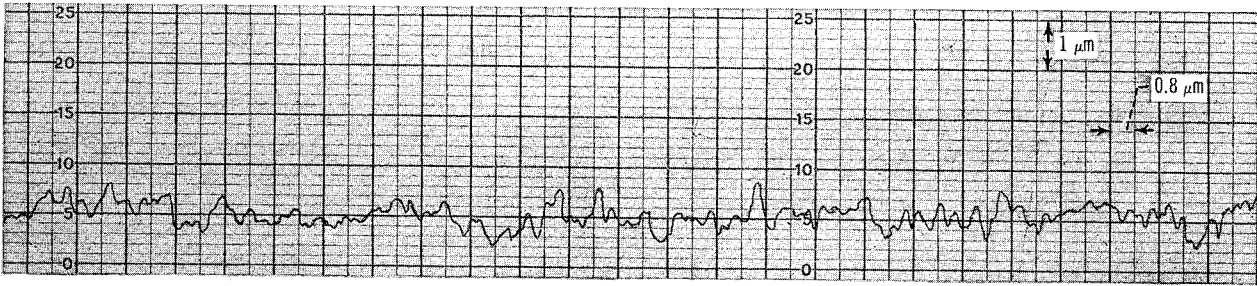
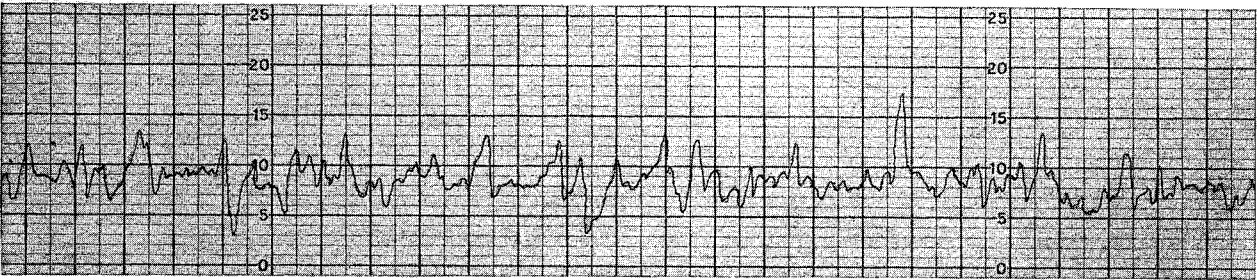

Figure 4. - Typical interferometry photomicrographs and surface profile traces of new and repolished femoral ball specimens.



(a) Liquid hone.



(b) Fine grit blast.



(c) Glass bead blast.

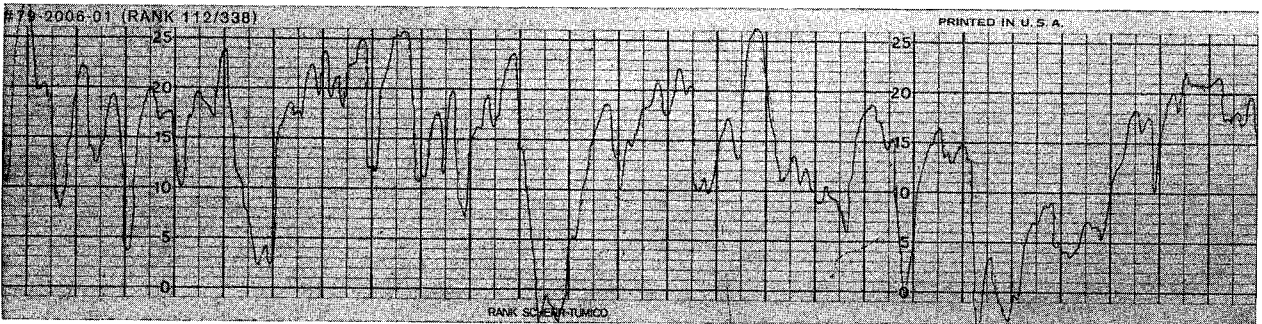

(d) Sand blast.

Figure 5. - Typical surface profile traces of femoral ball with different surface topography.

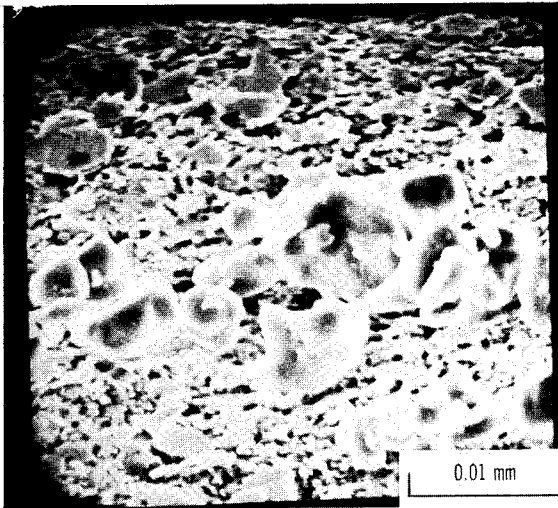

(a) Aluminum oxide powder.

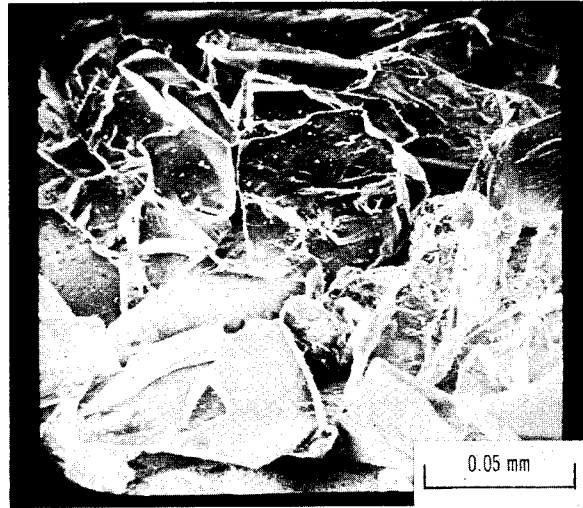

(b) Aluminum oxide grit.

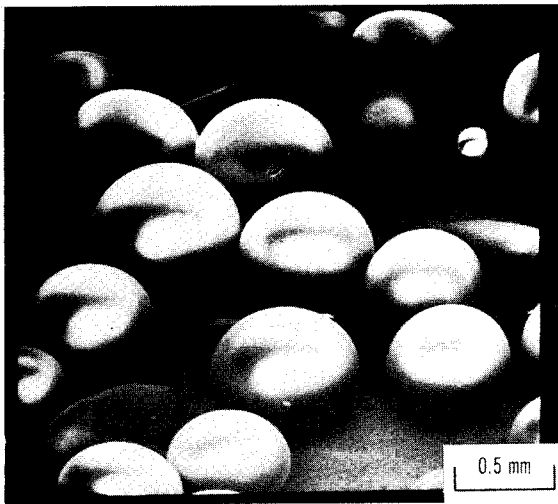

(c) Silica glass.

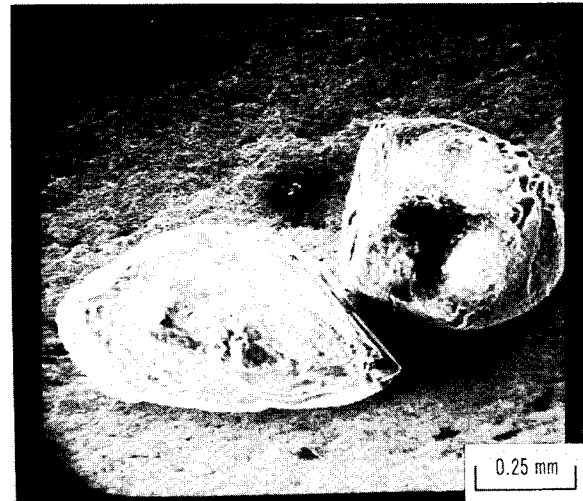

(d) Silica sand.

Figure 6. - Scanning electron micrographs of solids used in surface blasting of femoral ball specimens.

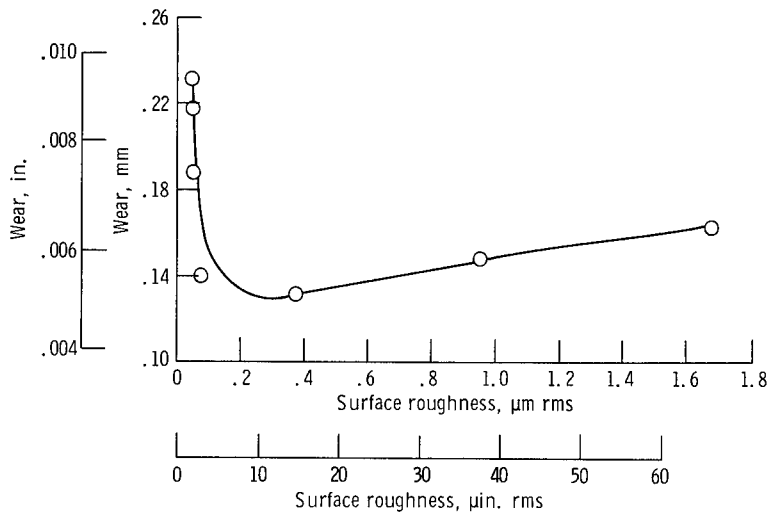

Figure 7. - Effect of stainless steel surface roughness on wear of polyethylene (ref. 15).

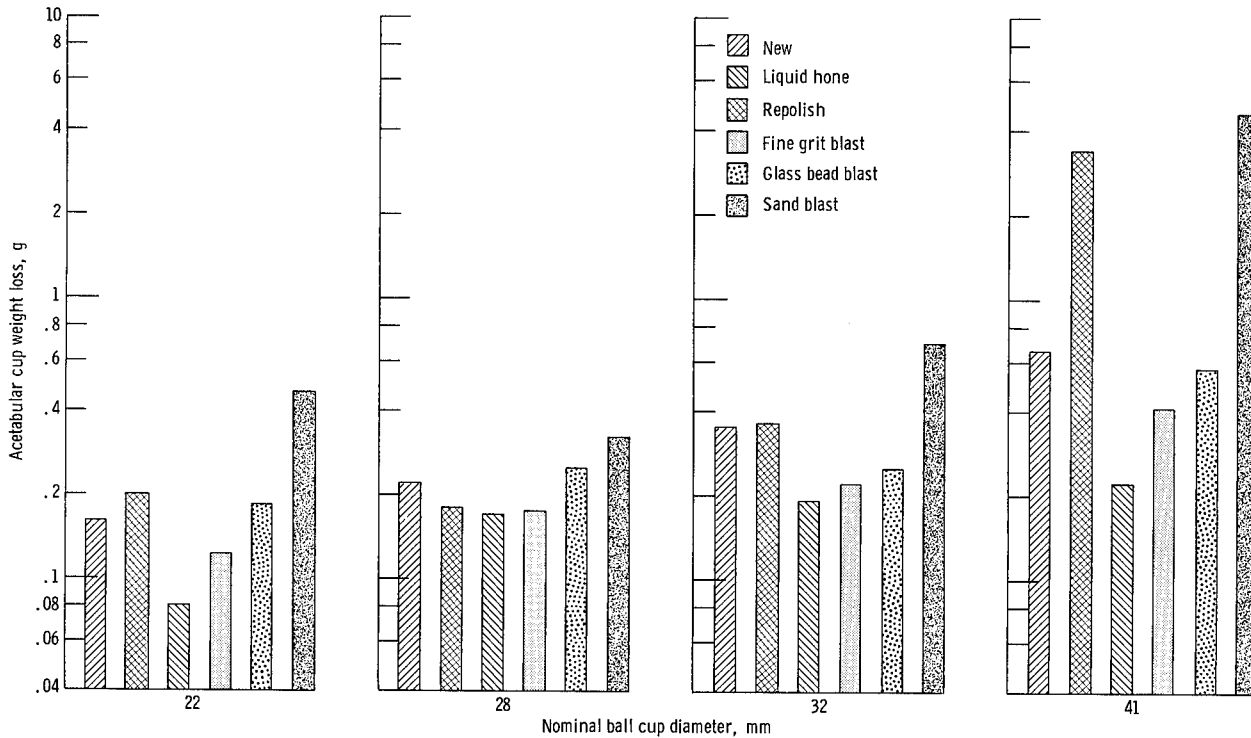
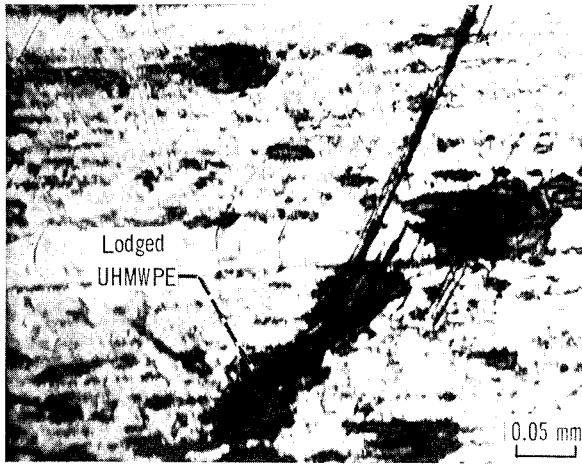
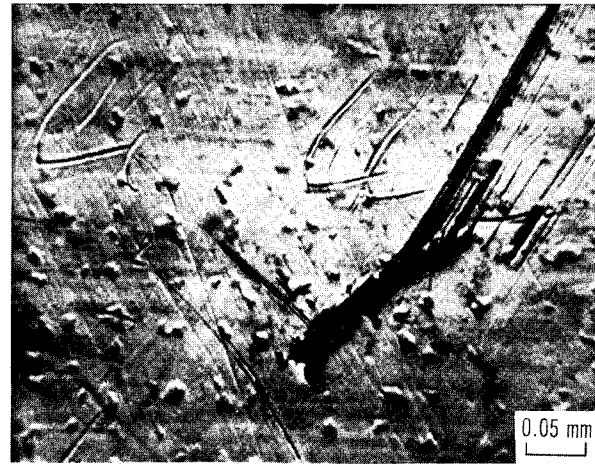

Figure 8. - Wear weight loss of UHMWPE acetabular cup run against cobalt-chromium femoral ball with various femoral ball diameter sizes and different ball surface topography. Simulated walking load and motions at 30 steps per minute.



(a) UHMWPE at surface scratch.



(b) Same surface with UHMWPE removed.

Figure 9. - Photomicrograph of typical polished cobalt-chromium alloy femoral ball specimen run against acetabular cup at walking load cycle for 8 hours at 30 steps per minute.

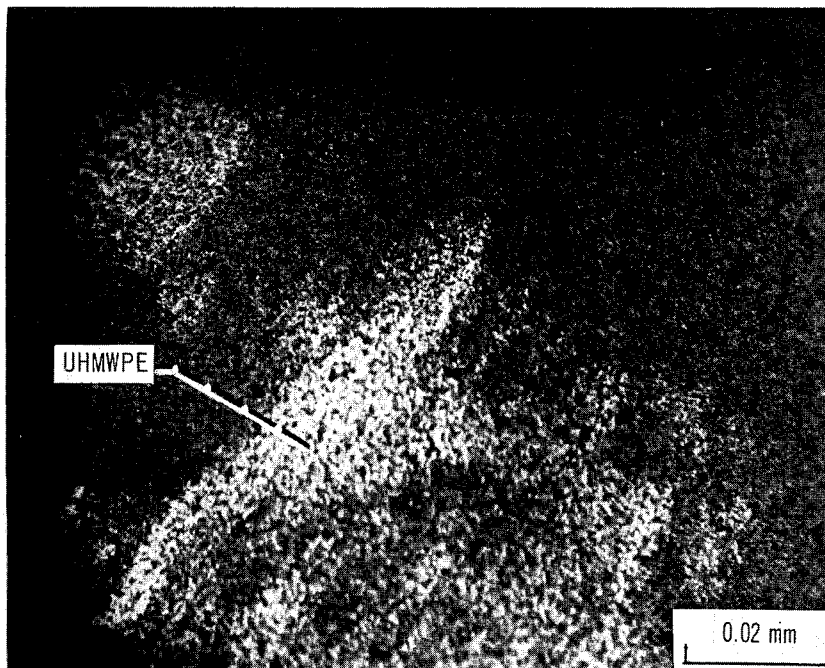

Figure 10. - Photomicrograph of liquid honed cobalt-chromium alloy femoral ball surface with UHMWPE transfer from a UHMWPE acetabular cup after running for 8 hours at walking load cycle at 30 steps per minute.

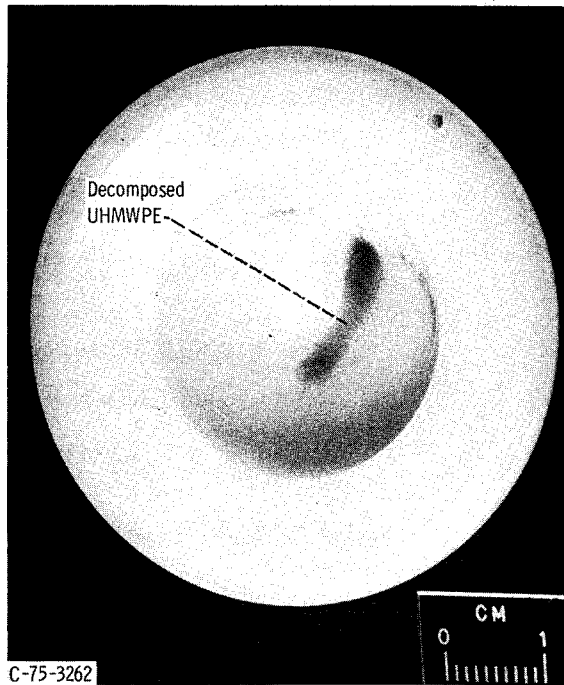

Figure 11. - UHMWPE acetabular cup with thermal decomposition of HDPE at sliding interface after running for 8 hours against fine grit blasted cobalt-chromium alloy femoral ball at walking load cycle at 30 steps per minute.

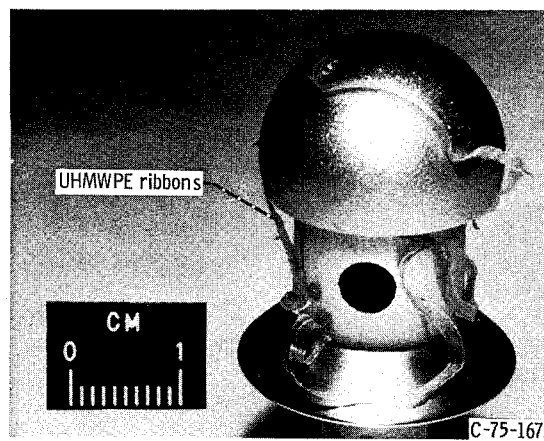

Figure 12. - Sand blasted cobalt-chromium femoral ball specimen with peeled ribbons of UHMWPE after running for 8 hours against UHMWPE acetabular cup for 8 hours at walking load cycle at 30 steps per minute.

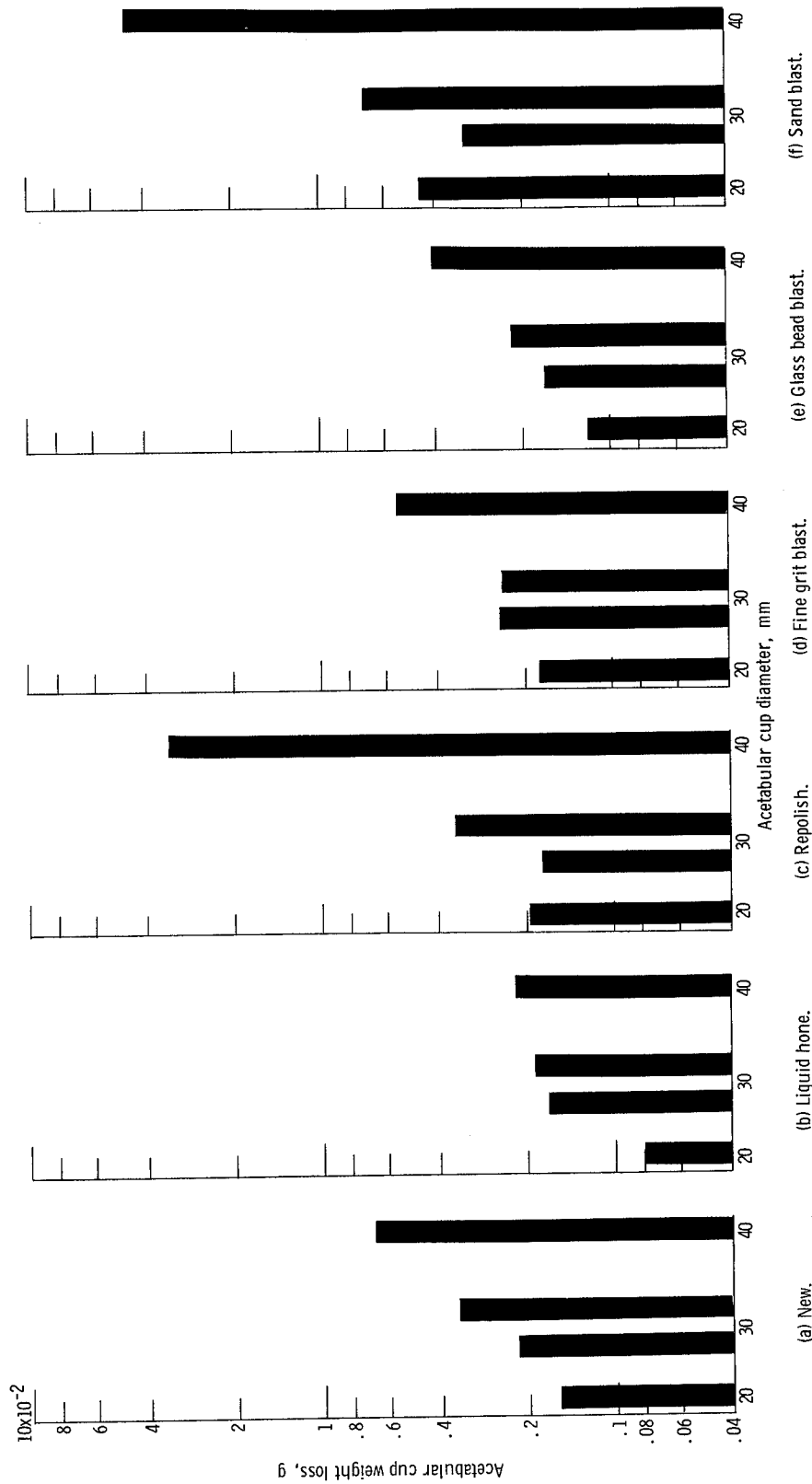

Figure 13. - Wear weight loss of UHMWPE acetabular cup on cobalt-chromium femoral ball with different surface topography. Simulated walking loads and motions at 30 steps per minute.

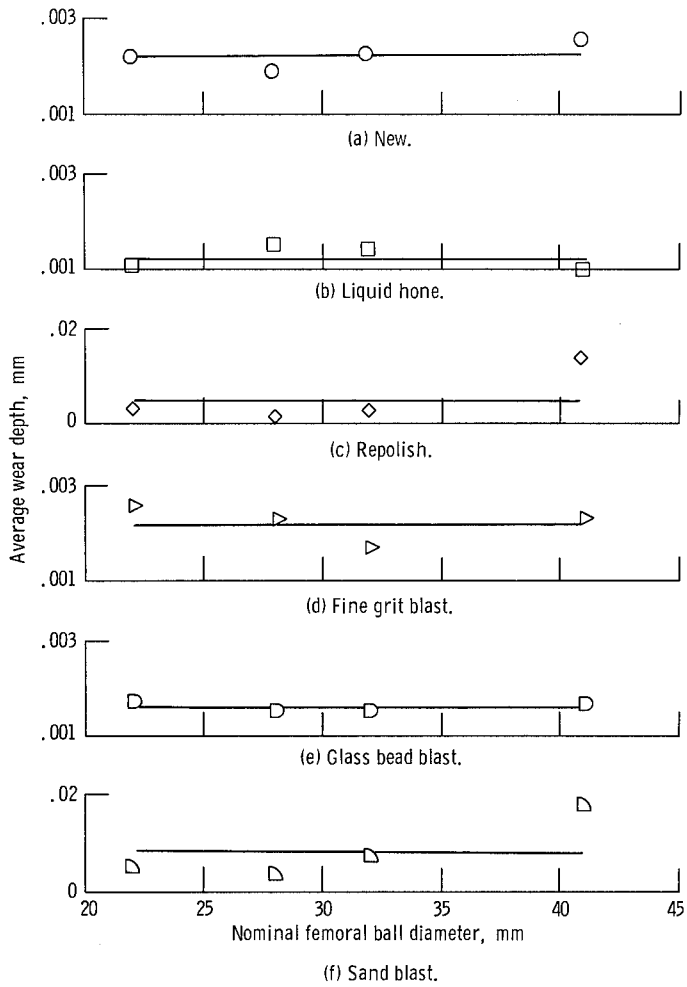

Figure 14. - Calculated wear depth from wear weight loss of UHMWPE acetabular cup run against cobalt-chromium femoral ball with different diameters and different surface topography at simulated walking loads and motions for 8 hours at 30 steps per minute.

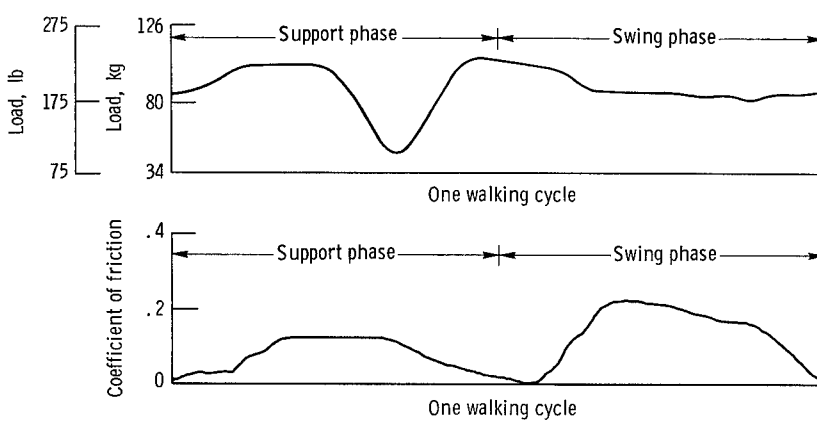

Figure 15. - Typical coefficient of friction and normal load traces for one walking cycle of cobalt-chromium alloy femoral ball sliding against UHMWPE acetabular cup at simulated walking motion of 30 steps per minute.

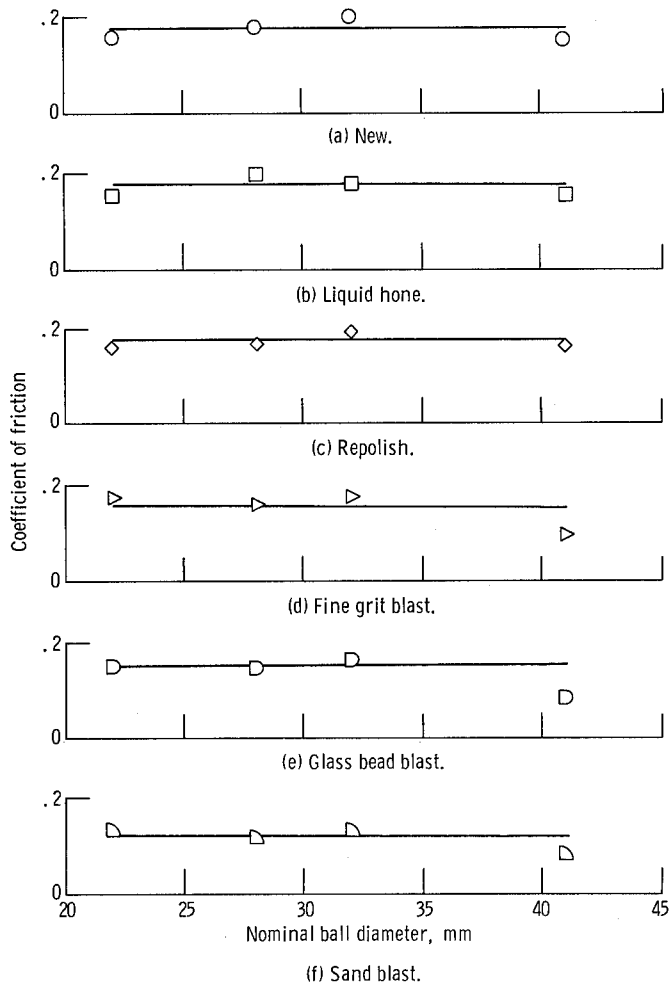

Figure 16. - Coefficient of friction for UHMWPE acetabular cup run dry against cobalt-chromium femoral ball with different surface topography. Friction values torque arm corrected to 22-millimeter diameter femoral ball size.

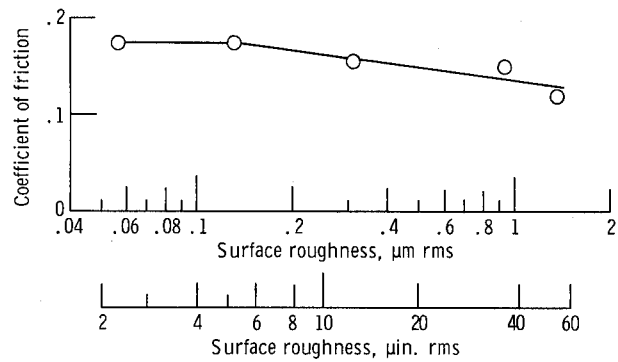
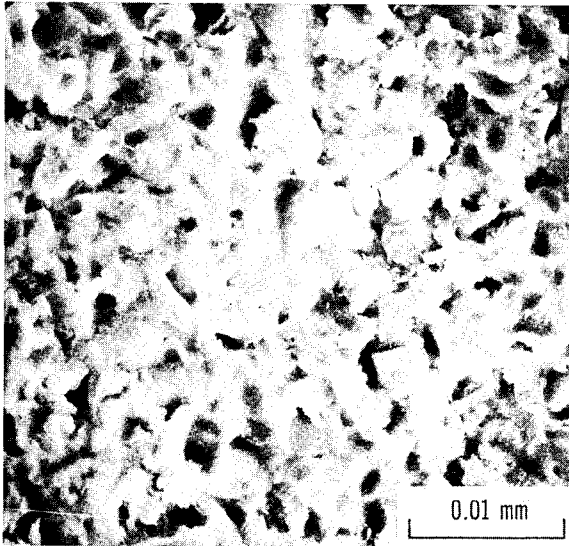
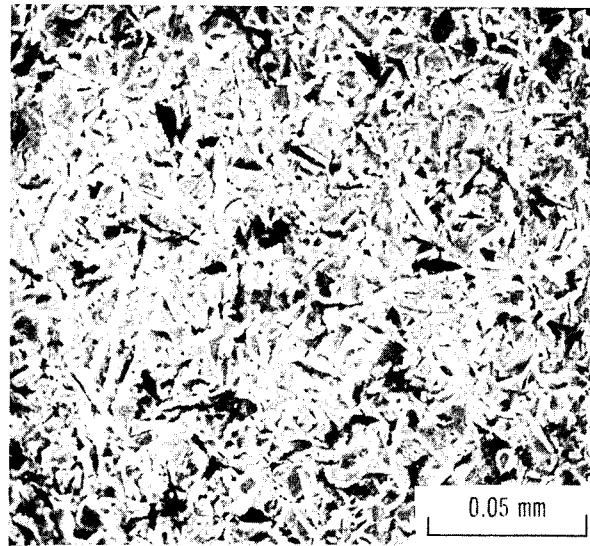

Figure 17. - Coefficient of friction against rms surface finish for UHMWPE acetabular cup run dry against cobalt-chromium femoral ball. Friction values torque arm corrected to 22-millimeter diameter femoral ball size.



(a) Aluminum oxide powder.



(b) Aluminum oxide grit.

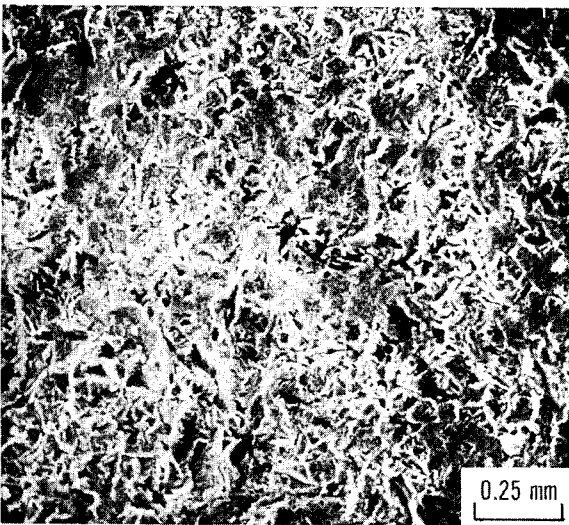

(c) Silica glass.

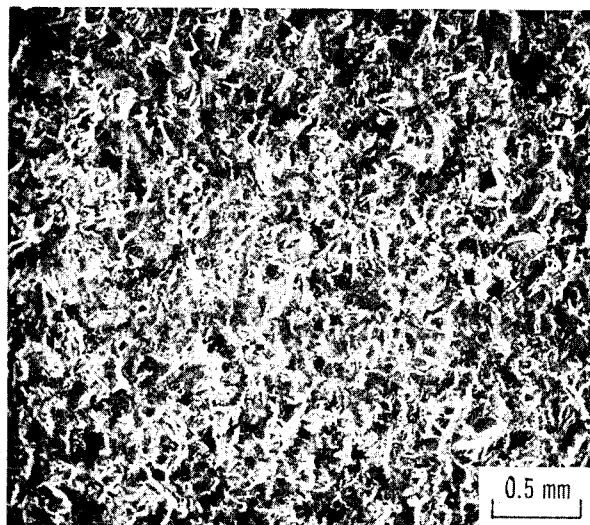

(d) Silica sand.

Figure 18. - Scanning electron photomicrographs of metal surfaces blasted with different solids.

NATIONAL AERONAUTICS AND SPACE ADMINISTRATION
WASHINGTON, D.C. 20546

OFFICIAL BUSINESS
PENALTY FOR PRIVATE USE \$300

SPECIAL FOURTH-CLASS RATE
BOOK

POSTAGE AND FEES PAID
NATIONAL AERONAUTICS AND
SPACE ADMINISTRATION
451



333 001 C1 U D 760220 S00942DS
DEPT OF THE ARMY
PICATINNY ARSENAL, BLDG 176
PLASTICS TECHNICAL EVALUATION CENTER
ATTN: A M ANZALONE, SARPA-FR-M-D
DOVER NJ 07801

176

If Undeliverable (Section 158
Postal Manual) Do Not Return

"The aeronautical and space activities of the United States shall be conducted so as to contribute . . . to the expansion of human knowledge of phenomena in the atmosphere and space. The Administration shall provide for the widest practicable and appropriate dissemination of information concerning its activities and the results thereof."

—NATIONAL AERONAUTICS AND SPACE ACT OF 1958

NASA SCIENTIFIC AND TECHNICAL PUBLICATIONS

TECHNICAL REPORTS: Scientific and technical information considered important, complete, and a lasting contribution to existing knowledge.

TECHNICAL NOTES: Information less broad in scope but nevertheless of importance as a contribution to existing knowledge.

TECHNICAL MEMORANDUMS: Information receiving limited distribution because of preliminary data, security classification, or other reasons. Also includes conference proceedings with either limited or unlimited distribution.

CONTRACTOR REPORTS: Scientific and technical information generated under a NASA contract or grant and considered an important contribution to existing knowledge.

TECHNICAL TRANSLATIONS: Information published in a foreign language considered to merit NASA distribution in English.

SPECIAL PUBLICATIONS: Information derived from or of value to NASA activities. Publications include final reports of major projects, monographs, data compilations, handbooks, sourcebooks, and special bibliographies.

TECHNOLOGY UTILIZATION PUBLICATIONS: Information on technology used by NASA that may be of particular interest in commercial and other non-aerospace applications. Publications include Tech Briefs, Technology Utilization Reports and Technology Surveys.

Details on the availability of these publications may be obtained from:

SCIENTIFIC AND TECHNICAL INFORMATION OFFICE

NATIONAL AERONAUTICS AND SPACE ADMINISTRATION

Washington, D.C. 20546