

CAIS STANDARD MANUAL

SYSTEM NO. 14 SITE ANTENNAS/ COMMUNICATIONS

19960320 103

DISTRIBUTION STATEMENT A
Approved for public release;
Distribution Unlimited

CAS PROJECT
CAIS MANUAL

Issued April 28, 1995

DTIC QUALITY INSPECTED 1

8 Mar 96

MEMORANDUM FOR DTIC-OCP

ATTN: Ms. Lue Lynch
8725 John J. Kingman Road, Suite 0944
Fort Belvoir, VA 22060-6218

FROM: AL/EQ (STINFO)
139 Barnes Drive, Suite 2
Tyndall AFB FL 32403-5323

SUBJECT: Transmission of Technical Documents

1. As per telephone conversation with Andrew Poulis, EQ/TIC, the attached CAIS CTDS manuals are forwarded for accession, cataloging, and microconversions. Please forward the accession numbers to:

Andrew Poulis
AL/EQ/TIC
139 Barnes Drive, Suite 2
Tyndall AFB, FL 32403-5323

2. The Distribution statement should read as follows: Approved for Public Release:
Distribution Unlimited.

3. If you have questions about these documents, please contact Andrew Poulis at DSN
523-6285.

LARRY L. TESTERMAN
Scientific and Technical
Information Program Manager

Atchs: Manuals

14 SITE ANTENNAS/COMMUNICATIONS

TABLE OF CONTENTS

	PAGE
ABSTRACT	iii
SYSTEM 14 SITE ANTENNAS/COMMUNICATIONS	
INSPECTOR'S GUIDE	1
I. General	1
II. General Inspection	1
III. Inspector Qualifications	2
IV. Inspection Unit (IU)	2
V. Unit Costs	3
VI. Standard Safety Requirements	3
VII. Standard Tools	4
VIII. Special Tools and Equipment Requirements	4
IX. Level II Inspection Method Keys	4
X. Level III Inspection Method Keys	4
XI. Replacement Costs	4
XII. Appendices	5
SYSTEM TREE	6
SUBSYSTEM 14.01 ANTENNA/COMMUNICATION SYSTEMS	
DESCRIPTION	7
Special Tool and Equipment Requirements	7
Special Safety Requirements	7
Component List	7
Related Subsystems	7
Standard Inspection Procedure	8
Components	8
References	19
Guide Sheet Control Number	20
Level II Inspection Method Guide Sheets	21
Level III Inspection Method Guide Sheets	23

14 SITE ANTENNAS/COMMUNICATIONS

PAGE

APPENDICES

APPENDIX A - ABBREVIATIONS A-1

APPENDIX B - GLOSSARY B-1

APPENDIX C - LIFE CYCLE C-1

14 SITE ANTENNAS/COMMUNICATIONS

ABSTRACT

GENERAL ORGANIZATION

At this installation the list of facilities to be surveyed, including infrastructure, will be addressed on the basis of 32 unique systems that form the CAIS Engineering Deficiency Standards and Inspection Methods document. Each system deals with a specific technical aspect of the facility to be surveyed. Within each system a further breakdown is made to subsystems, each having a related list of components. Detailed observations of the listed defects are provided so as to allow the entry of observed quantification data. A DOD CAIS manual is provided for each of the 32 systems with an internal organization as outlined below:

INSPECTOR'S GUIDE

- I. General
 - A. Level I Inspection Method Description
 - B. Level II Inspection Method Description
 - C. Level III Inspection Method Description

- II. General Inspection
 - A. Process. This section describes the process of the inspection activity.
 - B. Location. This section describes the procedure for locating the inspection units in the facility or infrastructure on this installation.

- III. Inspector Qualifications

This section notes the minimum qualifications for the person or persons performing the survey.

- IV. Inspection Unit

This section describes how the IU (Inspection Unit) is determined for the particular component being surveyed.

- V. Unit Costs

This section notes the nature of repair costs for this system.

- VI. Standard Safety Requirements

This section lists safety procedures and equipment required to implement a safe environment for the conduct of this survey.

- VII. Standard Tools

This section lists a set of standard tools required for the general conduct of this survey.

- VIII. Special Tools and Equipment Requirements

This section refers to special tools or equipment requirements endemic to the nature of the system being surveyed.

14 SITE ANTENNAS/COMMUNICATIONS

IX. Level II Inspection Method Keys

This section explains the use of keys as they relate to Level II Guide Sheets.

X. Level III Inspection Method Keys

This section explains the use of keys as they relate to Level III Guide Sheets.

XI. Replacement Cost

This section describes the nature and location of replacement cost data.

XII. Appendices

Appendix A. Provides a listing and definition of all abbreviations used both in the Standards and in the data base.

Appendix B. Provides a glossary of terms with their definitions as used in the Standard.

Appendix C. This section contains a listing of the average life cycle durations for each assembly* in the Standard.

- * Assembly is a term describing the level at which replacement rather than repair occurs. This can be at the subsystem or component designation, depending on the system being surveyed.

SYSTEM TREE

The System Tree is a graphical representation of the Work Breakdown Structure, showing system, subsystem and component relationships for the Site Antennas/Communications System.

INSPECTION METHODS

Description

Describes the nature of what is to be condition surveyed.

Special Tool and Equipment Requirements

Lists any special tools required for this specific subsystem.

Special Safety Requirements

This section outlines any special safety measures or equipment required for this specific subsystem so as to maintain a safe environment and process in the conduct of the condition survey.

Component List

All components to be surveyed under this subsystem are listed here.

Related Subsystems

All other subsystems that have a survey relationship to this subsystem are listed here to help coordinate a complete and thorough condition assessment survey.

14 SITE ANTENNAS/COMMUNICATIONS

Standard Inspection Procedure

This statement indicates the various levels of survey effort required for this subsystem.

Components

The previously listed components of this subsystem are described with a survey procedure recommended on a component by component basis. For each component there is a listing of defects with each defect broken down into observations describing the nature and severity of the defective condition observed. The surveyor enters a quantification value for each defect/observation encountered in the field CAIS device (DCD) to record the result of his survey.

References

This page lists the reference sources from which the foregoing subsystem data was developed.

Guide Sheet Control Number

This section lists the key numbers that tie the written Level II and Level III guide sheets to specific components in this subsystem.

Level II and Level III Inspection Method Guide Sheets

This section contains the detailed descriptions of the Level II and III survey and inspection procedures for this subsystem.

14 SITE ANTENNAS/COMMUNICATIONS

INSPECTOR'S GUIDE

I. GENERAL

A. Level I Inspection Method

Level I Inspection Method for site antennas/communications assets consist of a thorough inspection of the support structures, hardware, signal cables and waveguides as described in the work breakdown structure. The standard inspection is a walk-around visual inspection aided by binoculars and is designed to be performed by one person. The inspector is not required to climb structures or towers to perform the inspection or inspect concealed components at this level.

B. Level II Inspection Method

Level II Inspection Method for site antennas/communications assets will consist of a detailed investigation of selected components directed toward detecting damaged or deteriorated areas which cannot be determined by a Level I inspection. This standard of inspection is essentially designed to be performed by one person and is to be made without changing the operational status of the equipment.

C. Level III Inspection Method

For site antennas/communications assets, the Level III inspector will be conducting a highly-detailed and thorough investigation to determine the full extent of hidden or interior damage and the loss of material thickness. Level IIIs often require the use of advance inspection and testing techniques, such as ultrasonic testing for determining voids and thicknesses and infrared scanners for measuring hot spots at connections. Level III investigations often require cleaning of structural elements. Since cleaning is time consuming, it is generally restricted to areas that are critical, suspect or which may be typical of the entire structure.

II. GENERAL INSPECTION

A. Process

The work inspection is normally conducted at the component level. Figure 14.00-A provides the breakdown from system through component for the Site Antennas/Communications area.

The inspector will work through the Work Breakdown Structure (WBS) to conduct the inspection. At the component level the inspector will be provided a list of defects, each of which is described further as observations. These observations are described to various levels of severity as they relate to the effect on the life of the system. The quantification of each deficiency is identified by the inspector using the associated unit of measure. Once an observation is populated with a defect quantity, the inspector will be requested to provide information on component type and location.

14 SITE ANTENNAS/COMMUNICATIONS

II. GENERAL INSPECTION (Continued)

The installation date or age of the component may be preloaded into the WBS for each asset from the Real Property Inventory List or site specific information. This can be overridden by the inspector, Site CAIS personnel, or Facility Manager.

B. Location

Level I and II inspections will be located by the inspector through a discrete entry into the Data Collection Device. The "IU" or component location will be derived from Facility-supplied segment numbering lists, maps or other I.D. numbering systems. For building associated "IU's" and components the Facility shall furnish plans annotated with room number schedules. In the case of non-room associated components, plans will be orientated with the top of each sheet being the north direction, so as to allow directional location and description. In the case where no maps, or plans are available the inspector shall enter a brief (65 character) description of location.

III. INSPECTION QUALIFICATIONS

Minimum inspector qualifications, for the Site Electrical System, require a five year journeyman. Experience or familiarity in the areas of site electrical power system construction is desirable but not required. All of the survey requirements for this system can be accomplished by a single CAS surveyor, however safety and other considerations will require the inspector to work with local electrical maintenance personnel that are low and medium voltaged system qualified. CAS surveyors will be trained in the CAS system and its usage, and will be CAIS certified.

IV. INSPECTION UNIT (IU)

Example: The IU is normally defined at the subsystem level. If the unit of measure at the subsystem level is each, then the IU is each. If the unit of measure is square feet or linear feet, the IU is determined by the identification of location (i.e., a tower or pole number). Occasionally the IU will occur at the component level. Where this occurs it will be noted in the component description.

IU's may include one occurrence of each component or multiple occurrence of a single component (e.g., multiple foundations occur in an antenna support system, but only one tower). Deficiency quantities are captured by the inspector for each occurrence within the discrete component (deficiency quantities are tied to each foundation as a unique component, but the component, Tower, may have only one discrete unit since it is a contiguous component).

14 SITE ANTENNAS/COMMUNICATIONS

IV. INSPECTION UNIT (IU) (Continued)

For Example: The inspector locates 2 SF of surface scaling on the foundation of the north tower leg. A quantity of "2" is recorded in the field CAIS for the component, Foundation, located by the IU defined at the subsystem level as Antennas/Communications. As the inspection continues on the IU, the inspector finds another 2 SF of surface scaling. This is recorded by editing the initial 2 SF to read 4 SF with a number of occurrences as two. The IU itself is the entire Antennas/Communications, the discrete component is foundations. As the inspector moves to a different component, such as Insulators, multiple discrete components may exist. Deficiency quantities will be tied to each discrete component, Insulators, which in turn a component of the IU Antennas/Communications. So defects on the first insulators will be linked together and distinguishable from defects captured on the 2nd or 3rd insulator.

For the above example, an occurrence is defined as a defect (or observation) which is detected within the inspector's line of vision. If the inspector has multiple defects (or observations) in an occurrence within the same discrete component, the inspector will quantify the observation that is considered most severe and identify the remaining quantity under the less severe observation for the discrete component.

For Example: 3 SF of foundation is scaling, but within that 3 SF, 1.5 SF has exposure of reinforcing steel. The inspector will quantify 1.5 SF under the observation, exposure of reinforcing steel, and 1.5 SF under the observation, loss of surface from 1/2" to 1" deep, with coarse aggregates clearly exposed.

V. UNIT COSTS

The unit cost that are applied to the quantities recorded for each observation are contained within the Site CAIS as repair cost.

VI. STANDARD SAFETY REQUIREMENTS

The Master Safety Plan will be followed at all times during the inspections.

Inspector may utilize the following protective gear:

- Hard hat - to be worn in designated areas
- Safety glasses - to be worn in designated areas
- Safety shoes - to be worn during all inspections
- Ear plugs - to be worn in designated areas
- Knee pads - to be worn when crawling
- Gloves, electrically insulated - to be worn when working around live electrical components

14 SITE ANTENNAS/COMMUNICATIONS

VII. STANDARD TOOLS

- Employee Identification Card - to be worn or carried during all inspections
- Data Collection Device (DCD)
- Battery pack for DCD
- Flashlight
- Tape measure - 25'
- Tool bag
- Screwdrivers - with insulated handles
 - Phillips
 - Straight slot
- Insulated pliers

VIII. SPECIAL TOOLS AND EQUIPMENT REQUIREMENTS

At subsystem level, the deficiency standard has identified special tools and equipment required for the standard inspection of the associated components, which exceed the standard tools identified for the system. Level III Inspection Method Guide Sheets will address additional tools and equipment requirements that are specific to that particular method. Inspectors should review these sections in order to determine any special tool requirements for subsystems they are to inspect.

IX. LEVEL II INSPECTION METHOD KEYS

Certain observations will reference a Level II Inspection Method. The Facility Manager will be able to identify deficiencies where a Level II is flagged. The Level II Key at the observation level will refer to a specific Guide Sheet.

All Level II Guide Sheets are located at the end of each Subsystem section. A Guide Sheet Reference page precedes Level II and Level III Guide Sheets.

X. LEVEL III INSPECTION METHOD KEYS

Certain observations will reference a Level III Inspection Method. The Facility Manager will be able to identify deficiencies where a Level III is flagged. The Level III Key at the observation Level will refer to a specific guide sheet. These guide sheets may refer the Facility Manager to a more sophisticated and costly test method.

All Level III Guide Sheets are located at the end of each Subsystem section. A Guide Sheet Reference page precedes Level II and Level III Guide Sheets.

XI. REPLACEMENT COST

A replacement cost for each subsystem type will be contained within the cost estimating system in the Site CAIS.

14 SITE ANTENNAS/COMMUNICATIONS

XII. APPENDICES

Appendix A - Abbreviations

A summary and definition of abbreviations used in this system are contained in Appendix A which is located at the end of Site Antennas/Communications.

Appendix B - Glossary

A glossary of terms used in this system are contained in Appendix B which is located at the end of Site Antennas/Communications.

Appendix C - Life Cycles

A listing of the average life cycle durations for each assembly* in the Standard.

Note - Facility Manager's Guide

The following are included in the Facility Manager's Guide:

A table showing the required manhours to perform the standard inspection for this facility listed by Cat Code (three digit).

A listing of all Level III inspections with their estimated cost and time to perform. This list will include frequency of inspection for time driven Level III's.

* Assembly is a term describing the level at which replacement rather than repair occurs. This can be at the subsystem or component designation, depending on the system being surveyed.

14 SITE ANTENNAS/COMMUNICATIONS

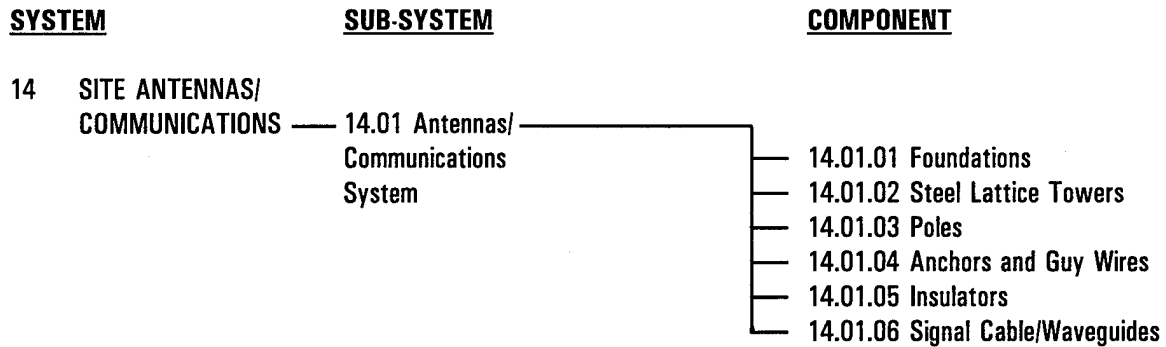
Figure 14-A. WORK BREAKDOWN STRUCTURE

14.01 ANTENNA/COMMUNICATION SYSTEMS

DESCRIPTION

Antenna/Communication Systems are a subsystem of Site Antennas/Communications. Antenna systems provide a medium in which electromagnetic waves are produced and radiated outward in space to receiving antennas.

This guide will address the support structure, hardware, and signal cable/waveguides and not the antenna itself.

SPECIAL TOOL AND EQUIPMENT REQUIREMENTS

The following special tools, beyond the requirements listed in the Standard Tool Section shall be provided as required to perform the inspection of the Antenna/Communication Systems.

1. Binocular, 10X50 power
2. Ice Pick
3. Hammer

SPECIAL SAFETY REQUIREMENTS

No special safety requirements are needed for the inspection of the Antenna/Communication Systems, beyond the requirements listed in the Master Safety Plan and System Safety Section.

COMPONENT LIST

- ◆ 14.01.01 FOUNDATIONS
- ◆ 14.01.02 STEEL LATTICE TOWERS
- ◆ 14.01.03 POLES
- ◆ 14.01.04 ANCHORS AND GUY WIRES
- ◆ 14.01.05 INSULATORS
- ◆ 14.01.06 SIGNAL CABLES/WAVEGUIDES

RELATED SUBSYSTEMS

Due to the related nature of the elements requiring inspection, the following should be reviewed for concurrent inspection activities.

- 10.06 RACEWAYS
- 29.06 EXTERIOR LIGHTING SYSTEM
- 29.07 LIGHTNING PROTECTION/GROUNDING SYSTEM

14.01 ANTENNA/COMMUNICATION SYSTEMS

STANDARD INSPECTION PROCEDURE

Components require a Level I or Level II inspection as part of the basic inspection process. Other additional Level II inspection may be indicated or "triggered" by a Level I inspection and should be accomplished by the inspector at that time. Level III inspection may be indicated or "triggered" by a Level I or II inspection defect/observation and should be accomplished at the direction of the Facility Manager.

Inspection should be carried out in the order of presentation for the various components with associated defects and observations, for each subsystem, listed in the inspector's CAIS.

COMPONENTS

◆ 14.01.01 FOUNDATIONS

Foundations consist of cast-in-place concrete footings and piers through which the loads of structures are transmitted to the earth. Anchor bolts are embedded in the concrete to connect the structure or equipment to the foundation.

Defect:	UOM	LEVEL II KEY	LEVEL III KEY
* Cracking:			
Observation:			
a. Cracks, between 1/16" and 1/4" wide.	LF		1
***{Severity M}			
b. Disintegration of surface or cracks exceeding 2" depth.	LF		1
***{Severity H}			
Defect:			
* Spalling:			
Observation:			
a. Not more than 1" deep or 6" in diameter.	SF		
***{Severity L}			
b. More than 1" in depth or 6" in dia., or 10% of surface area loss.	SF		
***{Severity H}			
c. Disintegration of surface area, with corrosion of exposed rebar.	SF		2
***{Severity H}			

14.01 ANTENNA/COMMUNICATION SYSTEMS

COMPONENTS (Continued)

◆ 14.01.01 FOUNDATIONS (Continued)

Defect:	UOM	LEVEL II KEY	LEVEL III KEY
* Scaling:			
Observation:			
a. Surface loss of 1/2" to 1" deep with coarse aggregates exposed. ***{Severity M}	SF		
b. Loss of surface exceeding 1" deep. ***{Severity H}	SF		
c. Exposure of reinforcing steel. ***{Severity H}	SF		2
Defect:			
* Reinforcing Steel Corrosion:			
Observation:			
a. Rusting evident, cracks occurring along rebar. ***{Severity H}	LF		2

14.01 ANTENNA/COMMUNICATION SYSTEMS

COMPONENTS (Continued)

◆ 14.01.02 STEEL LATTICE TOWERS

There are two types of steel lattice towers; self-supporting and guyed. Lattice towers usually have three, four or more legs. These legs are interconnected by a frame work of formed metal bars to make a tower.

Legs of guyed towers converge to a single point at the base of the tower to form a single connection point to the foundation. Guy wires hold the guyed tower in an upright position. Self-supporting tower legs are supported by individual foundations.

These towers are used to support overhead power lines, microwave antennas, radar equipment, radio antennas, light fixtures, observation platforms and other loads that need to be supported above the surrounding area.

Insulators and Conductors (BARE) shall be inspected under separate components.

Defect:	UOM	LEVEL II KEY	LEVEL III KEY
* Corrosion:			
Observation:			
a. Surface corrosion (no pitting evident).	SF		
***{Severity L}			
b. Corrosion evidenced by pitting or blistering.	SF		
***{Severity M}			
c. Corrosion evidenced by holes or loss of base metal.	SF		
***{Severity H}			
* Deformation of Gusset Plate:			
Observation:			
a. Pack rust between gusset plate and member 1/32".	EA		3
***{Severity L}			
b. Pack rust between gusset plate and member 1/16".	EA		3
***{Severity M}			
c. Pack rust between gusset plate and member 1/8".	EA		3
***{Severity H}			

14.01 ANTENNA/COMMUNICATION SYSTEMS

COMPONENTS (Continued)

◆ 14.01.02 STEEL LATTICE TOWERS (Continued)

Defect:	UOM	LEVEL II KEY	LEVEL III KEY
* Fasteners (Bolts or Rivets):			
Observation:			
a. Fastener loose.	EA		3
***{Severity M}			
b. Fastener missing.	EA		3
***{Severity H}			
Defect:			
* Steel Members:			
Observation:			
a. Steel member bent.	EA		3
***{Severity M}			
b. Steel member cracked, broken or missing.	EA		3
***{Severity H}			
Defect:			
* Electrical:			
Observation:			
a. Unit not grounded.	EA		
***{Severity H}			

14.01 ANTENNA/COMMUNICATION SYSTEMS

COMPONENTS (Continued)

◆ 14.01.03 POLES

There are five basic types of poles; steel, aluminum, concrete, wood and fiberglass. They are mainly used to support lighting fixtures, overhead power lines, communication cables, traffic signals, antennas and radar equipment.

Poles mainly consist of pole bases, anchor bolts/nuts, base cover plates, transformer bases, mounting brackets, lighting fixture arms, cross arms, lowering devices and safety cage platforms.

Surge (lightning) arresters, disconnect switches, insulators and conductors (bare) shall be inspected under their separate component inspection.

Defect:	UOM	LEVEL II KEY	LEVEL III KEY
* Corrosion Damage to Steel Poles:			
Observation:			
a. Surface corrosion (no pitting evident). ***{Severity L}	SF		
b. Corrosion evidenced by pitting or blistering. ***{Severity M}	SF		
c. Corrosion evidenced by holes or loss of base metal. ***{Severity H}	EA		
* Decay, Insect and Bird Damage to Wood Pole Structures:			
Observation:			
a. Knothole decay. ***{Severity L}	EA		4
b. Wood colored indicating wood decay. ***{Severity M}	SF		4
c. Holes made by birds. ***{Severity M}	EA		4
d. Fungi fruit indicating wood decay. ***{Severity H}	SF		4
e. Signs of parasite damage (carpenter ants and termites). ***{Severity H}	EA		4
f. Decay detected by hammer sounding near base of pole. ***{Severity H}	EA		4

14.01 ANTENNA/COMMUNICATION SYSTEMS

COMPONENTS (Continued)

◆ 14.01.03 POLES (Continued)

Defect:	UOM	LEVEL II KEY	LEVEL III KEY
* Crack Damage to Concrete Poles:			
Observation:			
a. Surface spalling more than 1" deep or 6" in diameter.	SF		
***{Severity L}			
b. Cracks greater than 1/16 inch wide.	LF		
***{Severity M}			
Defect:			
* Physical Damage:			
Observation:			
a. Base plate broken or missing.	EA		
***{Severity L}			
b. Handhole coverplate broken or missing.	EA		
***{Severity L}			
c. Transformer base cover plate broken or missing.	EA		
***{Severity L}			
d. Wood pole 1" or less deep horizontal scar.	LF		
***{Severity L}			
e. Pole leaning (2 foot or more at top).	EA		
***{Severity M}			
f. Transformer base broken.	EA		
***{Severity M}			
g. Fixture mounting brackets bent or loosely mounted.	EA		
***{Severity M}			
h. Crossarm brackets/supports missing.	EA		
***{Severity M}			
i. Fiberglass pole damaged (opening in pole).	EA		
***{Severity M}			
j. Metal pole dented (more than 1" indentation).	EA		
***{Severity M}			
k. Wood pole with 1" to 2-1/2" deep horizontal scar.	LF		
***{Severity M}			

14.01 ANTENNA/COMMUNICATION SYSTEMS

COMPONENTS (Continued)

◆ 14.01.03 POLES (Continued)

Defect:	UOM	LEVEL II KEY	LEVEL III KEY
* Physical Damage (Continued):			
l. Anchor nut missing. ***{Severity H}	EA		
m. Hinged pole mechanism broken or damaged. ***{Severity H}	EA		
n. Cage platform broken or damaged. ***{Severity H}	EA		
o. Lighting fixture lowering device broken or damaged. ***{Severity H}	EA		
p. Wood pole more than 2-1/2" deep scar. ***{Severity H}	LF		
q. Wood pole splintered by lightning. ***{Severity H}	LF		
r. Pole not grounded. ***{Severity H}	EA		

14.01 ANTENNA/COMMUNICATION SYSTEMS

COMPONENTS (Continued)

◆ 14.01.04 ANCHORS AND GUY WIRES

Anchors occur as many different types with multiple variations of each type. Normally the anchors are underground except for the guy wire terminal attachment hardware. Excavation to inspect the underground portion of the anchor will destroy the integrity of the anchor being inspected. Only exposed section of the anchor will be inspected.

Guy wires connect the structure requiring support to an anchoring device. An anchoring device can either be an underground anchor or an above-ground device. Above-ground anchoring devices are either self-supporting or guyed structures.

Guy wires are steel stranded cables with either galvanized, copper or aluminum coating.

Anchoring system failure is indicated by either the top of the supported structure leaning away from the anchoring point or the supported structure intact but laying on the ground.

Defect:	UOM	LEVEL II KEY	LEVEL III KEY
* Corrosion:			
Observation:			
a. Surface corrosion (no pitting evident).	LF		
*** {Severity L}			
b. Corrosion evidenced by pitting or blistering.	LF		
*** {Severity M}			
c. Corrosion evidenced by holes or loss of base metal.	EA		
*** {Severity H}			

14.01 ANTENNA/COMMUNICATION SYSTEMS

COMPONENTS (Continued)

◆ 14.01.04 ANCHORS AND GUY WIRES (Continued)

Defect:	UOM	LEVEL II KEY	LEVEL III KEY
* Physical Damage:			
Observation:			
a. Guy wire guard missing or detached. ***{Severity L}	EA		
b. Guy wire strand broken. ***{Severity M}	EA		
c. Vegetation growth on guy wire. ***{Severity M}	EA		
d. Clamping hardware fasteners loose or missing. ***{Severity H}	EA		
e. Guy wire broken. ***{Severity H}	EA		
f. Anchor creep (pole leaning away from anchor). ***{Severity H}	EA		
g. Guy (strain) insulator damaged. ***{Severity H}	EA		
h. Clamping hardware missing. ***{Severity H}	EA		

14.01 ANTENNA/COMMUNICATION SYSTEMS

COMPONENTS (Continued)

◆ 14.01.05 INSULATORS

Insulators are intended to give flexible or rigid support to electrical conductors or equipment and to electrically separate those conductors or equipment from ground or from other construction components, conductors, or equipment. An insulator can consist of one or more non-conducting parts to which metal fittings are permanently attached.

A variety of insulators are used in distribution applications including; pin insulators, suspension insulators, deadending insulators, line post insulators, station post insulators, spool insulators, and guy strain insulators.

Defect:	UOM	LEVEL II KEY	LEVEL III KEY
* Corrosion:			
Observation:			
a. Surface corrosion (no pitting evident).	SF		
***{Severity L}			
b. Corrosion evidenced by pitting or blistering.	SF		
***{Severity M}			
c. Corrosion evidenced by holes or loss of base metal.	EA		
***{Severity H}			
Defect:			
* Physical Damage:			
Observation:			
a. Insulator chipped or cracked	EA		
***{Severity M}			
b. Insulator broken or missing.	EA		
***{Severity H}			
c. Insulator mounting broken	EA		
***{Severity H}			
Defect:			
* Hot Spots:			
Observation:			
a. Terminal 5° to 24°C above ambient.	EA	1	5
***{Severity M}			
b. Terminal 25°C or more above ambient.	EA	1	5
***{Severity H}			

14.01 ANTENNA/COMMUNICATION SYSTEMS

COMPONENTS (Continued)

◆ 14.01.06 SIGNAL CABLES / WAVEGUIDES

Signal cables are used on low-power circuits and have an insulation voltage rating of 600 volts or less. These cables are used in instrumentation, communications, radio transmission & reception and low-power appliance signal circuits, e.g., doorbells, buzzers, code-calling systems, signal lights, etc. Signal cable types include single wire, paired cable, coaxial cable, optical fibers and waveguides.

Waveguides conduct or guide the energy in microwave antenna systems. These take on various shapes such as rectangular, round, elliptical and sometimes square, depending on the application.

Defect:	UOM	LEVEL II KEY	LEVEL III KEY
* Physical Damage:			
Observation:			
a. Cable, improper termination. ***{Severity L}	EA		
b. Exposed insulation frayed or brittle. ***{Severity L}	EA		
c. Exposed insulation cracked or discolored. ***{Severity L}	EA		
d. Exposed conductor, improper splice. ***{Severity M}	EA		
e. Defective/deficient cable penetration. ***{Severity M}	EA		
f. Exposed cable not properly supported. ***{Severity H}	EA		
g. Exposed cable not properly protected. ***{Severity H}	LF		
h. Conduit sagging more than 2 inches between supports. ***{Severity H}	EA		
i. Waveguide dented. ***{Severity H}	LF		
j. Waveguide flange damaged. ***{Severity H}	EA		

14.01 ANTENNA/COMMUNICATION SYSTEMS

REFERENCES

1. DOE Volume 2:0.02, Substructure Deficiency Standards and Inspections Method
2. MEANS Concrete Repair and Maintenance, Peter Emmons, 1994
3. NAVFAC MO-322, Inspection of Shore Facilities, Volume II, January 1993
4. DOE CAS Manual, Volume 9: 0.09 Electrical
5. Encyclopedia of Telecommunications, Robert A. Meyers, Editor
6. Means Facilities Maintenance & Repair Cost Data, 1994

14.01 ANTENNA/COMMUNICATION SYSTEMS

LEVEL II KEY GUIDE SHEET CONTROL NUMBER

1 GS-II 14.01.05-1

LEVEL III KEY GUIDE SHEET CONTROL NUMBER

1 GS-III 14.01.01-1
2 GS-III 14.01.01-2
3 GS-III 14.01.02-3
4 GS-III 14.01.03-4
5 GS-III 14.01.05-5

LEVEL II INSPECTION METHOD GUIDE SHEET

LEVEL II GUIDE SHEET - KEY NO. 1

COMPONENT: INSULATORS
CONTROL NUMBER: GS-II 14.01.05-1

Application

This guide applies to the investigation of the inside of an enclosure, containing bare, energized, electrical parts.

Special Safety Requirements

The following list of special safety requirements, beyond the requirements listed in the Master Safety Plan and System Safety Section, are to be observed in the performance of this inspection.

1. This inspection guide applies to enclosures containing live electrical parts having a potential of 600 volts or less above ground. If the enclosure contains circuitry of higher potential, do not use this inspection guide.
2. Any enclosure that is padlocked for safety reason is not to be opened unless okayed by the person having control of the key.
3. Inspector needs to carefully open, inspect the inside and close the enclosure without shutting down the equipment, and without creating a hazard to himself.

Inspection Actions

1. Open panels or doors carefully and to the degree required for scanning those devices being tested.
2. Make temperature measurements with an infrared scanner.
3. Measure the ambient temperature by measuring a spot on the inside of the enclosure that is least effected by any internal panel heat source.
4. Measure the temperature of the device specified.
5. Above-ambient temperature is calculated by subtracting the ambient temperature from the device temperature.
6. Record the results.
7. Close panels or doors carefully after the inspection is complete.

LEVEL II INSPECTION METHOD GUIDE SHEET

LEVEL II GUIDE SHEET - KEY NO. 1 (Continued)

COMPONENT: INSULATORS
CONTROL NUMBER: GS-II 14.01.05-1

Recommended Inspection Frequency

Do a Level II inspection each time a Level I inspection is made.

References

1. Maintenance Technology/September 1993; Write-up Title: *"Infrared Keeps All Systems Go"*
2. Raining - Agema Infrared Systems; *"Measurement of Excess Temperatures with Infrared Scanners"*

LEVEL III INSPECTION METHOD GUIDE SHEET

LEVEL III GUIDE SHEET - KEY NO. 1

COMPONENT: FOUNDATIONS
CONTROL NUMBER: GS-III 14.01.01-1

Application

This guide applies to the investigation of cracks in concrete.

Special Safety Requirements

No special safety requirements are needed for the performance of this Level III inspection beyond those required in the Master Safety Plan and System Safety Section.

Inspection Actions

1. Utilize ultrasonic pulse velocity equipment to check for damage extent and loss of integrity.

Special Tools and Equipment

The following is a list of special tools required beyond those listed in the Standard Tool Section.

1. Ultrasonic pulse velocity test equipment, Krautkramer Branson #USK-6

Recommended Inspection Frequency

When triggered by a Level I or II defect/observation.

References

1. DOE, Vol. 2:0.02. *"Substructure Deficiency Standards and Inspection Methods Manual"*
2. MEANS *"Concrete Repair and Maintenance"*, Peter H. Emmons, 1994

LEVEL III INSPECTION METHOD GUIDE SHEET

LEVEL III GUIDE SHEET - KEY NO. 2

COMPONENT: FOUNDATIONS
CONTROL NUMBER: GS-III 14.01.01-2

Application

This guide applies to the investigation of corrosion of reinforcing steel in concrete.

Special Safety Requirements

No special safety requirements are needed for the performance of this Level III inspection beyond those required in the Master Safety Plan and System Safety Section.

Inspection Actions

1. Clean rust/discoloration.
2. Perform half-cell potential test to determine degree of corrosion of steel reinforcement.

Special Tools and Equipment

The following is a list of special tools required beyond those listed in the Standard Tool Section.

1. Half-cell test equipment.

Recommended Inspection Frequency

Whenever Level I or II defect/observation triggers this Level III procedure.

References

1. DOE, Vol. 2:0.02. *"Substructure Deficiency Standards and Inspection Methods Manual"*
2. MEANS *"Concrete Repair and Maintenance"*, Peter H. Emmons, 1994

LEVEL III INSPECTION METHOD GUIDE SHEET

LEVEL III GUIDE SHEET - KEY NO. 3

COMPONENT: STEEL LATTICE TOWERS
CONTROL NUMBER: GS-III 14.01.02-3

Application

This guide determines the extent of defects recorded in Level I inspection of steel lattice towers. This Level III inspection is performed to evaluate the observed defect and to develop maintenance or remedial measures required to monitor, control or correct the existing deficiencies.

Special Safety Requirements

No special safety requirements are needed for the performance of the Level III inspection beyond those required in the Master Safety Plan and System Safety Section.

Inspection Actions

1. Prior to making a field inspection of the observed defect, review all past inspection records concerning the steel lattice tower.
2. Perform inspection of observed defects that triggered this Level III inspection.
3. Make an assessment of the importance of the individual observed defects and indicate whether continued observation, maintenance, or remedial work is required.
4. Prepare cost estimate for doing the required maintenance or remedial repair work, as applicable.

Special Tools & Equipment Requirements

Grinder or sand blasting equipment
Industry required testing equipment needed to perform the advanced investigation method chosen

Recommended Inspection Frequency

Do a Level III inspection when triggered by a Level I inspection.

References

1. Bridges Inspector's Training Manual/90 by U.S. Department of Transportation

LEVEL III INSPECTION METHOD GUIDE SHEET

LEVEL III GUIDE SHEET - KEY NO. 4

COMPONENT: ANCHORS AND GUY WIRES
CONTROL NUMBER: GS-III 14.01.03-4

Application

This guide applies to the investigation of decay in wood poles.

Special Safety Requirements

No special safety requirements are needed for the performance of this Level III inspection beyond those required in the Master Safety Plan and System Safety Section.

Inspection Actions

Observation inspection will detect above ground grade decay and parasite infestation only. If there is above ground grade deterioration there may be greater deterioration at 6 to 9 inches below grade.

1. Remove backfill from around the poles to a depth of 9 inches.
2. Probe, with ice pick, for decay material or parasite infestation in the exposed areas above and below the grade. Probing should be made in suspected areas from 9" below ground grade to top of pole, including bird damaged areas.
3. Remove all located decay or parasite damage material.
4. Provide written descriptions of the material damage, giving depths and volumes of each effected area.
5. Structural Engineer shall study the finding to determine if:
 - a. Poles should be treated only to prevent further damage in these areas.
 - b. Poles should be treated to prevent further damage and reinforced by a C truss reinforcement method or by other applicable means.
 - c. Poles have been damaged beyond repair and must be replaced.

LEVEL III INSPECTION METHOD GUIDE SHEET

LEVEL III GUIDE SHEET - KEY NO. 4 (Continued)

COMPONENT: ANCHORS AND GUY WIRES
CONTROL NUMBER: GS-III 14.01.03-4

Special Tools and Equipment

The following is a list of special tools required beyond those listed in the Standard Tool Section.

1. D Handle Shovel
2. Wood Chisel
3. Ice pick
4. Binocular, 10 x 50 power

Recommended Inspection Frequency

Whenever Level I or Level II defect/observation triggers this Level III procedure.

References

1. Electrical World, March 1991, Vol 205, No. 3
2. NAVFAC MO-322, Vol II, January 1993

LEVEL III INSPECTION METHOD GUIDE SHEET

LEVEL III GUIDE SHEET - KEY NO. 5

COMPONENT: INSULATORS
CONTROL NUMBER: GS-III 14.01.05-5

Application

This guide applies to the investigation of a hot terminal or device that is overheating from the flow of current through that terminal or device.

Special Safety Requirements

No special safety requirements are needed for the performance of this Level III inspection beyond those required in the Master Safety Plan and System Safety Section.

Inspection Actions

1. Verify the findings of Level II inspection by using the Infrared Scanner and measuring the temperatures of the device and terminals. If the device or terminals are not hot as indicated by the findings of Level II inspection, check the current flow through the device or terminals. Heat generated is proportionate to the square of the current. If there is little or no current flow through the device or terminal at the time of measurement, there will be no significant amount of heat generated.
2. For terminal connections, verify the type of conductor being terminated. If the conductor is an aluminum conductor, look for evidence of cold flow or melt down of conductor.
3. If there is evidence of cold flow or melt down of the aluminum conductor, the conductor should either be replaced or shortened and reconnected. When making new aluminum conductor terminations a joint compound should be used.
4. If the terminal is loose it should be tightened. De-energize prior to attempting tightening of terminal connections.
5. If none of the above is the problem than there is an internal problem and an on-site analysis must be made to determine if additional inspections are to be made or the unit is to be replaced.

LEVEL III INSPECTION METHOD GUIDE SHEET

LEVEL III GUIDE SHEET - KEY NO. 5 (Continued)

COMPONENT: INSULATORS
CONTROL NUMBER: GS-III 14.01.05-5

Special Tools and Equipment

The following is a list of special tools required beyond those listed in the Standard Tool Section.

1. Infrared Scanner, Raytek, Inc., #PM2EM-L2
2. Torque wrench
3. Digital Multimeter, Fluke #1TC676

Recommended Inspection Frequency

Do a Level III inspection when triggered by a Level II inspection.

References

1. Maintenance Technology/September 1993; Write-up Title: *"Infrared Keeps All Systems Go"*
2. Raining - Agema Infrared Systems; *"Measurement of Excess Temperatures with Infrared Scanners"*

APPENDIX A

ABBREVIATIONS

AASHTO	American Association of State Highway and Transportation Officials
ADF	Asset Determinant Factor
A/E	Architect/Engineer
AFM	U.S. Air Force Manual
AGC	Associated General Contractors
AGGR OR AGGRED	Aggregate
Amp	Ampere
ANSI	American National Standards Institute
ARTBA	American Road and Transportation Builders Association
AVG	Average
AWG	American Wire Gauge
BKRS	Breakers
BLDG	Building
BLKS	Blocks
BOCA	Building Official Code Association
°C	Degrees Centigrade (Celsius)
CAIS	Condition Assessment Inspection Survey
CAS	Condition Assessment Survey
COE	U.S. Army Corps of Engineers
COR	Contracting Officer Representative
CRKS	Cracks
CSI	Construction Specification Institute
CT	Current Transformer
D	Durability

APPENDIX A

DC	Direct Current
DCD	Data Collection Device
DIA	Diameter
DM	NAVFAC Design Manual
DOD	U.S. Department of Defense
DOE	U.S. Department of Energy
DS&IM	Deficiency Standard and Inspection Method
EA	Each
EL	Elevation
EM	U.S. Army Engineering Manual
EMS	Energy Management System
EPA	U.S. Environmental Protection Agency
Est	Estimated
EXCESSV	Excessive
°F	Degrees Fahrenheit
Ft	Foot, feet
FVNR	Full Voltage, Non-Reversing
FVR	Full Voltage, Reversing
Galv	Galvanized
GS	Guide Sheet
HID	High Intensity Discharge
HOA	Hand-Off-Automatic
HP	Horsepower
HR	Hour
HS	High Severity

APPENDIX A

HVAC	Heating, Ventilating, and Air-Conditioning
Hz	Hertz, frequency
HZRD	Hazard
IC	Integrated Circuit
IEEE	Institute of Electrical and Electronic Engineers
IES	Illumination Engineering Society
INFILTRAT	Infiltration
INRSE	Intersecting
IR	Infrared
ITIM	Intrusive Test and Inspection Method
IU	Inspection Unit
KA	Kiloampere
KV	Kilovolt
kVA	kiloVolt Ampere
kVAR	Kilovar
kW	kiloWatt
kWh	kiloWatt hour
LF	Linear Feet
LO	Low
LONGIT	Longitudinal
LS	Low Severity
MAX	Maximum
MC	Major Command/Major Claimant
MCC	Motor Control Center
MED	Medium

APPENDIX A

Mfg	Manufacturing
Mfr	Manufacturer
Mhz	Megahertz
MOD	moderately
MOISTUR	moisture
MS	Medium Severity
MSDS	Material Safety Data Sheet
MVA	Million-Volt-Amps
MYMARP	Multi-Year Maintenance and Repair Plan
NAVFAC	Naval Facilities Engineering command
NDT	Non-Destructive Testing
NEMA	National Electrical Manufacturers Association
NFPA	National Fire Protection Association
NSTIM	Non-Standard Testing and Inspection Method
OD	Outside Dimension
OSHA	Occupational Safety and Health Administration
PB	Pushbutton
PCB	Polychlorinated biphenyls
PCS	Pieces
PL	Pilotlight
PT	Potential Transformer
PVC	Polyvinyl Chloride
QA	Quality Assurance
Reqd	Required
RPFM	Real Property and Facilities Management (U.S. DOE)

APPENDIX A

RPI	Real Property Inventory
RPIL	Real Property Inventory List
RPIS	Real Property Inventory System (U.S. DOE)
RV	Reduced Voltage
RVA	Reduced Voltage Autotransformer
RVRes	Reduced Voltage Reactor
SCR	Silicon - Controlled Rectifier
SEVRL	Several
SF	Square feet
SFTY	Safety
SIM	Standard Inspection Method
SS	Stainless Steel
TEMP	Temporary
TM	U.S. Army technical manual
TR	DOD technical report
TRAFF	Traffic
TRANSVS	Transverse
TRAVLD	Traveled
UL	Underwriters Laboratory
UNSATISF	Unsatisfactory
UOM	Unit of Measure
UPS	Uninterruptible Power Supply
USCE	U.S. Army Corps of Engineers
V	Volt
VAC	Voltage, Alternating Current

APPENDIX A

VDC	Voltage, Direct Current
VEHC OR VHC	Vehicle
W	Watt
WBS	Work Breakdown Structure
WKS	Weeks
Yrs	Years
2S1W	Two Speed, single winding
2S2W	Two Speed, two winding
2MC	Two Magnetic Contractors
°F	Degrees Fahrenheit
°C	Degrees Centigrade (Celsius)
W/	With
<	Less Than
>	Greater Than
= <	Equal to or Less Than
= >	Equal to or Greater Than
%	Percent
"	Inch or Inches
'	Foot or Feet

APPENDIX B

GLOSSARY

Accessible	Capable of being removed or exposed without damaging the building structure or finish, or not permanently closed in by the structure or finish of the building (as applied to wiring methods).
Ancillary Equipment	Selected equipment such as but not limited to meters, instrument transformers and surge arrestors. Specifically, items of equipment installed or in place only as augmentation to another device.
Bonding	The permanent joining of metallic parts to form an electrically conductive path which will assure electrical continuity and the capacity to conduct safely any current likely to be imposed.
Branch Circuit	The circuit conductors between the final overcurrent device and the outlet(s).
Buildings	A structure which stands alone or which is cut off from adjoining structures by fire walls with all openings therein protected by approved fire doors.
Circuit Breakers	A device designed to open and close a circuit by nonautomatic means and to open the circuit automatically on a predetermined overcurrent, without damage to itself when properly applied within its rating.
Device	A unit of an electrical system which is intended to carry but not utilize electric energy.
Enclosure	The case of housing of apparatus, or the fence, or walls which will prevent persons from accidentally contacting energized parts.
Equipment	A general term including material, fittings, devices, appliances, fixtures, apparatus, and the like used as a part of, or in connection with, an electrical installation.
Feeder	All circuit conductors between the service equipment of the source of a separately derived system and the final branch circuit overcurrent device.
Fitting	An accessory such as a locknut, bushing, or other part of a wiring system that is intended primarily to perform a mechanical rather than an electrical function.
Instrumentation device	Devices that are utilized to test, observe, measure, monitor, alter, generate, record, calibrate, manage, or control physical properties, movements or other characteristics.

APPENDIX B

Insulator	(1) Power Switchgear. A device intended to give flexible or rigid support to electrical conductors or equipment and to insulate these conductors or equipment from ground or from other conductors or equipment. An insulator comprises one or more insulating parts to which connecting devices (metal fittings) are often permanently attached. (2) Transmission and distribution. Insulating material in a form designed to support a conductor physically and electrically separate it from another conductor or object.
Outlet	A point on the wiring system at which current is taken to supply utilization equipment.
Overcurrent	Any current in excess of the rated current of equipment or the ampacity of a conductor. It may result from overload, short circuit, or ground fault.
Overload	Operation of equipment in excess of normal, full-load rating, or of a conductor in excess of rated ampacity which, when it persists for a sufficient length of time, would cause damage or dangerous overheating. A fault, such as a short circuit or ground fault is not an overload.
Panelboard	A single panel or group of panel units designed for assembly in the form of a single panel; including bases, automatic overcurrent devices, and with or without switched for the control of light, heat, or power circuits; designed to be placed in a cabinet or cutout box placed in or against a wall of partition and accessible only from the front.
Raceway	An enclosed channel designed expressly for holding wires, cable, or busbars, with additional functions as permitted. Raceways may be of metal or insulating material, and the term includes rigid metal conduit, rigid nonmetallic conduit, intermediate metal conduit, liquid tight flexible conduit, flexible metallic conduit, electrical nonmetallic conduit, electrical metallic conduit, underfloor raceways, cellular concrete floor raceways, cellular metal floor raceways, surface raceways, wireways, and busyways.
Service Drop	The overhead conductors that extend from the last pole or other aerial support to and including the splices, if any, connecting to the service-entrance conductors at the building or other structure.

APPENDIX B

**Service Entrance
Conductors**

The service conductors between the terminals of the service equipment and point usually outside the building, clear of building walls, where joined by tap or splice to the service drop or the service conductors between the terminals of the service equipment and the point of connection to the service lateral. The service conductors may be individual insulated conductors or in the form of a cable. The insulation will be appropriate to the environmental application.

**Service Entrance
Equipment**

The necessary equipment, usually consisting of a circuit breaker or switch and fuses, and their accessories, located near the point of entrance of supply conductors to a building or other structure, or an otherwise defined area, and intended to constitute the main control and means of cutoff of the supply.

Service Lateral

The underground service conductors between the street main, including any risers at a pole or other structure or from transformers, and the first point of connection to the service entrance conductors in a terminal box or meter or the enclosure with adequate space, inside or outside the building wall. Where there is no terminal box, meter, or other enclosure with adequate space, the point of connection will be considered to be the point of entrance of the service conductors into the building.

Switchboard

A large single panel, frame, or assembly of panels on which are mounted, on the face or back or both, switches, overcurrent and other protective devices, buses, and usually instruments. Switchboards are generally accessible from the rear as well as from the front and are not intended to be installed in cabinets.

**Utilization
Equipment**

Equipment which utilizes electric energy for mechanical, chemical, heating, lighting, or similar purposes.

APPENDIX C

LIFE CYCLES**14 SITE ANTENNAS/COMMUNICATIONS****14.01 FOUNDATIONS**

Foundations	50 YRS
Steel Lattice Towers	50 YRS
Steel, Aluminum, Concrete and Fiberglass Poles	50 YRS
Wood Poles	50 YRS
Anchors and Guy Wires	50 YRS
Insulators	50 YRS
Signal Cables/Waveguides	50 YRS

Source:

MEANS Facilities Maintenance & Repair Cost Data, 1994
AASHTO - AGC - ARTBA Joint Committee Task Force 32 Report
Valmont Pole Manufacturer
Whaltery Pole Manufacturer
Illinois Power Company
Joslyn Corporation