**COMBAT RATION
ADVANCED MANUFACTURING
TECHNOLOGY DEMONSTRATION
(CRAMTD)**

**"Alternate Filling of MRE Placeables"
Short Term Project (STP) #15**

**FINAL TECHNICAL REPORT
Results and Accomplishments (June 1994 through August 1995)
Report No. CRAMTD STP #15 - FTR13.0
CDRL Sequence A004
February 1996**

CRAMTD CONTRACT NO. DLA900-88-D-0383
CLIN 0003

Sponsored by:
DEFENSE LOGISTICS AGENCY
8725 John J. Kingman Road
Ft. Belvoir, VA 22060-6221

Contractor:
Rutgers, The State University of New Jersey
THE CENTER FOR ADVANCED FOOD TECHNOLOGY*
Cook College
N.J. Agricultural Experiment Station
New Brunswick, New Jersey 08903

Principal Investigator: M.M. Ogot

DISTRIBUTION STATEMENT A
Approved for public release
Distribution Unlimited

19960313 064

Dr. John F. Coburn
Program Director

TEL: 908-445-6132
FAX: 908-445-6145

REPORT DOCUMENTATION PAGE

Form Approved
OMB No. 0704-0188

Public reporting burden for this collection of information is estimated to average 1 hour per response, including the time for reviewing instructions, searching existing data sources, gathering and maintaining the data needed, and completing and reviewing the collection of information. Send comments regarding this burden estimate or any other aspect of this collection of information, including suggestions for reducing this burden, to Washington Headquarters Services, Directorate for Information Operations and Reports, 1215 Jefferson Davis Highway, Suite 1204, Arlington, VA 22202-4302, and to the Office of Management and Budget, Paperwork Reduction Project (0704-0188), Washington, DC 20503.

1. AGENCY USE ONLY (Leave blank)	2. REPORT DATE February 1996	3. REPORT TYPE AND DATES COVERED Final Jun 1994 - Aug 1995
---	--	--

4. TITLE AND SUBTITLE Alternate Filling of MRE Placeables (Short Term Project - STP #15)	5. FUNDING NUMBERS C-DLA900-88D-0383 PE - 7811s PR - 88003
---	--

6. AUTHOR(S) M. M. Ogot	
-----------------------------------	--

7. PERFORMING ORGANIZATION NAME(S) AND ADDRESS(ES) Rutgers, The State University of New Jersey The Center for Advanced Food Technology Cook College, NJ Agricultural Experiment Station New Brunswick, NJ 08903	8. PERFORMING ORGANIZATION REPORT NUMBER FTR 13.0
--	---

9. SPONSORING/MONITORING AGENCY NAME(S) AND ADDRESS(ES) Defense Logistics Agency 8725 John J. Kingman Road Ft. Belvoir, VA 22060-6221	10. SPONSORING/MONITORING AGENCY REPORT NUMBER
---	---

11. SUPPLEMENTARY NOTES

12a. DISTRIBUTION/AVAILABILITY STATEMENT	12b. DISTRIBUTION CODE
---	-------------------------------

13. ABSTRACT (Maximum 200 words)

Following literature review, patent search and visit to a combat ration producer packaging a placeable item, the parameters required to vertically fill preformed MRE pouches with placeable items were identified. Four design concepts were analyzed and evaluated resulting in one being selected for further design and construction. In support of the design of the linkage-type dwell mechanism required for a vertical filler, a new design tool was developed. The single and double dwell examples tested resulted in 54% and 41% reductions in structural error thus facilitating the use of linkage-type dwells. However, a prototype, based on the three-dimensional computer models, was not constructed. Instead, funding from DOD allowed purchase of horizontal form/fill/seal machines at each of the MRE producers and these packaging lines replace vertical filled lines for placeable products. Therefore, no further design or construction was carried out. It is recommended that a design study, using the new tools and approach, be conducted for specific item filling of horizontal form/fill/seal pouches. Such a design study should include a cost/benefit analysis and comparison to robotic and manual filling.

14. SUBJECT TERMS	15. NUMBER OF PAGES 43
	16. PRICE CODE

17. SECURITY CLASSIFICATION OF REPORT Unclassified	18. SECURITY CLASSIFICATION OF THIS PAGE Unclassified	19. SECURITY CLASSIFICATION OF ABSTRACT Unclassified	20. LIMITATION OF ABSTRACT UL
--	---	--	---

Table of Contents

1.0 CRAMTD Final Report STP #15 Results and Accomplishments	1
1.1 Introduction and Background	1
1.2 Results and Conclusions	1
1.3 Recommendations	1
2.0 Program Management	2
2.1 Summary of STP Accomplishments.....	2
3.0 Short Term Project Activities	3
3.1 STP Phase I Task.....	3
3.1.1 Review of Current Technology (Task 3.3.1.1).....	3
3.1.2 Definition of System Parameters (Task 3.3.1.2).....	4
3.1.3 Development of Design Concepts (Task 3.3.1.3).....	4
3.2 STP Phase II Task.....	5
3.2.1 Design and Evaluation Analysis (3.3.2.1)	5
3.2.2 Definition of Mechanism Requirements.....	6
3.2.3 Synthesis of Several candidate six-link mechanism	6
3.2.4 Synthesis of Eight-Link Designs	7
3.3 Concluding Remarks	8
Tables and Figures	
4.0 Appendix	20
4.1 Figure 1 - CRAMTD FTR #15 Time and Events and Milestones	
4.2 List of Patents Found to be Relevant to STP #15	
4.3 Technical Working Paper (TWP) #108	

*A - per Russell Eggers
DLA/MMPT*

1.0 CRAMTD Final Report STP #15

Results and Accomplishments

This Final Technical Report covers the activities for CRAMTD Short Term Project, STP #15, "Alternate Filling of MRE Placeables" for June 1, 1994 - August 31, 1995.

1.1 Introduction and Background

The objective of this project was to develop systems to fill preformed MRE pouches with placeable items. First, a review of the current state of the art of the technology employed in food packaging and related industries was conducted. Against this backdrop, desired characteristics for the various systems were defined including operating methods and rates, physical descriptions and size constraints. Next, conceptual design of systems and devices were then considered. These concepts varied from very simple to fully automatic. This is followed by formulation of appropriate computer models to assist in the development and evaluation of each of the concepts. Finally, the selection of the most appropriate concept and a solid model of the system is performed.

1.2 Results and Conclusions

Following review of the literature, patent search and a visit to a combat ration producer packaging a placeable item, the parameters required for a viable system to fill preformed MRE pouches with placeable items were identified. Four design concepts were analyzed and evaluated resulting in one being selected for further design and construction.

In support of the synthesis of the linkage-type dwell mechanism required for the vertical filler, a new formulation was developed. The single and double dwell examples tested resulted in a 54% and 41% reduction in structural error thus facilitating the use of linkage-type dwells in mechanism designs. With this new design tool, the proposed concepts could be optimized.

However, a prototype, based on the three-dimensional computer models, was not constructed. Instead, funding from DOD allowed purchase of horizontal form/fill/seal machines at each of the MRE producers and these packaging lines replace verticals for placeable products. Therefore, no further design or construction was carried out.

1.3 Recommendations

The present CRAMTD approach to automated placeable filling of HFFS pouches is the robot. An advantage of robotic filling is the flexibility, through changeable grippers and computer programming, to handle multiple kinds of items. Possible robot disadvantages include higher capital cost and limited unit production rates (comparable to manual filling).

At low production volumes, manual filling can be cost effective with the highest possible flexibility (assuming sufficient floor space for workers). Dedicated item fillers can have cost

and productivity advantages at high volume, extended production. In general, they have limited flexibility.

It is recommended that a design study, along the lines of STP #15, be conducted for specific item filling of HFFS pouches. Such a design study should include a cost/benefit analysis compared to robotic and manual filling. In addition, the Preliminary Engineering needs to provide an item/filler characterization which could group together "similar" items (i.e., ham slice, cutlets, patties as rectangular slabs) thereby increasing the filler flexibility.

2.0 Program Management

This STP was proposed as a two phase activity as illustrated in Figure 1, "Time & Events and Milestones", (Appendix 4.1). These cover the following:

Phase I Review and Preliminary Engineering

Review Current Technology

Define System Parameters

Develop Design Concepts

Phase II Design and Evaluation Analysis

Testing and Evaluation

Economic Analysis

CRAMTD Coordination

Technology Transfer

Only the initial portion of Phase II, Testing and Evaluation, was completed at which point the project was suspended by the DOD.

2.1 Summary of STP Accomplishments

- Approximately 25 patents found to be directly applicable.
- A tour of one of the Combat Ration producers was received including inspection of their equipment for vertical filling of smokey franks into pouches.
- A list of eight (8) broad system parameters was identified to guide the project.
- Four promising design concepts were identified for further evaluation: the "hamslammer", the "dogger", the "conveyor", and the "drum assembly".
- Full solid model computer simulations of the four candidate concepts were conducted resulting in the selection of the "dogger".

- A new formulation of the linkage-type dwell mechanism synthesis problem was developed which was found to significantly reduce error without increasing computation time.
- A three dimensional computation model for the complete “dogger” mechanism was developed.

3.0 Short Term Project Activities

3.1 STP Phase I Task

3.1.1 Review of Current Technology (Task 3.3.1.1)

The process of establishing the current state of the technology pursued two avenues, (1) searching the literature and (2) reviewing current technology being employed in today's industries, through plant tours. A summary of the results from each of these initiatives are outlined in the following sections.

3.1.1.1 Literature Search

A thorough search of the literature, primarily trade magazines and scholarly journals, was initiated and concluded. Several insightful articles were found, the information contained therein to be incorporated in future designs. A patent search was also performed. Over 3,000 relevant patents were found and carefully studied to establish:

1. relevance to this task, and
2. applicability of some of the designs contained therein.

After the screening, approximately 25 of these were found to be directly applicable. The scope of the search, was not limited to the feeding of food items only, but also to the feeding of cylindrical objects. The cigarette industry turned up several good ideas that may be applicable. Here we were looking at the feeding of cigarettes into packs, a task very similar to the feeding of franks. A full compilation of the patents found to be relevant to the current project are listed in Appendix 4.2.

3.1.1.2 Industrial Liaisons.

On the industrial front, numerous roadblocks were encountered. Several companies whom at first seemed willing to allow possible plant tours, later indicated an unwillingness to host tours, citing the need to maintain propriety process information secret. However, a tour one of the facilities was agreeable. The information learned from the tour is summarized below.

At that facility, currently, franks are manually placed into a 'funnel' mechanism attached to the vertical form/fill/seal machine. A plunger above the funnel at the appropriate time forces the four franks into the pre-formed pouch below. With this set up, they can achieve rates of up to 20

pouches/min. Work is proceeding with the development of a mechanism to automatically feed franks into the funnel.

Consequently, this project relied heavily on the patent and literature searches to obtain the current state of the technology.

3.1.2 Definition of System Parameters (Task 3.3.1.2)

The following is list of broad system parameters that were identified:

- **Adaptability:** one machine for both franks and ham slices, with only minor adjustments necessary
- **Simplicity:** A simple device typically translates into ease of use, higher reliability and lower cost
- **Flexibility:** To allow for change in solid placeables, e.g. the addition of chicken breast
- **Division of the design task into three area:** (i) Feeding - getting the placeables from the bulk from into some order from which they can be placed into the pouches; (ii) Orientation - A means to orient the placeables such that they are vertical and lengthwise to facilitate feeding into the pouches: and (iii) Pouch Feeding - Actual getting the placeables into the pouches.
- **Size:** Develop devices which occupy minimum space
- **Seal Integrity:** It is essential to prevent contamination of seal
- **Division of task:** The design task was subdivided into Bulk-feeding, Orientation and Pouch Feeding
- **Target Production Rate:** 30 - 40 pouches per minute

Within each of these broad parameter categories, narrower parameters are being defined and enumerated.

3.1.3 Development of Design Concepts (Task 3.3.1.3)

Based on the system design criteria listed above numerous design concepts were developed. The four most promising are briefly described here.

3.1.3.1 Hamslammer

With reference to Figures 1 the placeables are stacked on a moveable rack that pushes the stack up after each removal. Initially, the top placeable (in this case ham slices) is directly adjacent to Piston 1. The piston pushes the top slice onto a shelf located next to the ham stack. Once positioned under the arm, the 'claws' from the arm grab the ham slice. The arm retracts upward, shortening the arm length, allowing ample room for upcoming movements. The entire arm, in the retracted position then swings a total of 90° toward the location of the pouch. At this position, the arm is pushed out to it's original length, and the ham slice against a back face. Piston 2 now comes down, forcing the placeable into the open pouch. After Piston 2 is raised to

its original position, the arm is retracted, swung back to its original position awaiting the next slice.

3.1.3.2 Dogger

This concept is illustrated with hot dogs as the placeable items (refer to Figure 2). The hot dogs are vertically fed onto the base through the feeder. Plunger 1 then pushes the hot dogs into the holder, which in turn rotates 90°, orienting the dogs vertically above the pouch. Two springs located at the bottom of the holder prevent the placeables from leaving the holder prematurely. Plunger 2 now pushes the placeables into the pouch, and returns to its original position. The holder and plunger 1, both return to their original positions, and the process is repeated. The vertical feeder can also be used to dispense ham. By removing the inner vertical panels, ham slices can be stacked inside the feeder, allowing them to be bulk fed in the same manner as the hot dogs.

3.1.3.3 The Conveyor

With this device placeables can be horizontally fed by either a conveyor belt or moving piston (refer to Figure 3). The placeables are moved into the orienting compartment. The latter is attached to a rotating arm. Once the arm has completed a 90° rotation, thereby orienting the placeable in a vertical position, a piston moves down into the compartment and pushes the placeable into the pouch below. The piston is subsequently retracted, the compartment and arm return to their original position to begin the cycle again.

3.1.3.4 The Drum Assembly

The final concept is illustrated in Figure 4. Placeables are pushed into the holder by the conveyor. The orienting compartment (holder) rotates inside of the drum for a quarter turn, ending up in a vertical position. From here, the holder remains vertical as it is positioned above the pouch by the drum. Once the plunger has pushed the placeable into the pouch and returned to its original position, the holder is reoriented to its original horizontal position by the drum. The sequence is then repeated.

3.2 STP Phase II Task

3.2.1 Design and Evaluation Analysis (3.3.2.1)

The four design concepts were evaluated to determine which one would merit further development. Full solid model computer simulations of their principal motions were carried out, and video taped. The following principal attributes were identified:

- Speed
- Size
- Ease of construction
- Versatility
- Simplicity

Using a decision matrix (refer to Table 1), the 'Dogger' concept, illustrated in Figure 2, was selected for further development. The numbers in the table are the relative scores. The weights refer to the relative importance given to each attribute.

3.2.2 Definition of Mechanism Requirements

In order to design and construct a mechanism to achieve the motion required by the 'dogger' concept, a precise definition of the motion of the two pistons, vis-a-vis the orientor (refer to Figure 5) is required. Figure 5 illustrates a sequence of positions for these three components, the two pistons and the orientor. The numbers represent a sequential point in time, i.e. each number shows the position of all three components at that point in time. Based on this information, it was found that the relative displacement of the two pistons are as illustrated in Figure 6. Note that the numbers on the graph correspond to the respective piston locations shown in Figure 5. The required stroke for piston 1 and 2 were determined to be four inches and seven inches, respectively.

The design problem can therefore be stated as follows: Design two mechanisms, each of which must have a rotary input and a slider output. In addition the following design requirements must be met.

1. The pistons must have 4" and 7" dwells, respectively, each corresponding to 120° of input crank rotation
2. Both mechanisms must be driven by a SINGLE input motor. Synchronization between the two pistons and the dwell requirements, as illustrated in Figure 5, must be accounted for.
3. Minimization of size and complexity, thereby cost, of required device.
4. Constant speed input motor for operation, thereby eliminating the need for any expensive control devices
5. Increase/decrease in cycle time must be achieved by merely altering the speed of the input motor. Synchronization and dwell requirements should still be maintained. Note that one cycle is defined as: (a) the feeding of the placeable into the orientor, (b) orientation of the placeable, (c) feeding of the placeable into the pouch, and (c) resetting of the mechanism for the next placeable.

3.2.3 Synthesis of Several Candidate Six-link Mechanism

Both mechanisms which drive pistons 1 and 2 have identical requirements, except for the stroke length. Subsequently, one need only design the mechanism to drive piston 1. Minor adaptation of this device yields the device for piston 2. The rest of the discussion in this section, therefore, will focus on the design of the mechanisms to drive piston 1. A six-link mechanism (Figure 7) was chosen for this task.

The problem can be stated as the synthesize a six-link planar mechanism to produce a single dwell. The six link mechanism consists of a four-bar crank rocker mechanism driving a slider crank from the coupler point. The dwell positions and duration can be specified at any value of input link rotation. The total stroke length may also be defined. The design variables are the

link lengths $R_1, R_2, R_3, R_4, R_5,$ and $R_7; R_6$ and f which specify coupler point; and R_8, R_9 and y which define the fixed slider path for a total of 12. The mechanism is required to travel 4 inches in the first 90° of input link rotation, dwell in this position for 120° , and return in the final 150° . A total of 8 precision points were used. The synthesis problem was reformulated as an optimization problem to minimize structural error, i.e.

$$\text{Min } F(\mathbf{x}) = \sum_{i=1}^8 (P(i) - z(\mathbf{x})_i)^2 \quad (8)$$

subject to: No branching

$$x_l(i) < x(i) < x_h(i)$$

where \mathbf{x} is the set of design variables, $z(\mathbf{x})_i$ is the position of the slider corresponding to the i^{th} precision point, and $x_l(i)$ and $x_h(i)$ are the lower and upper bounds of the i^{th} design variable, respectively. The position solution was obtained via the vector-loop approach (Hall, 1981). Optimization was carried out using the stochastic method Simulated Annealing With random search Iterative improvement, SAWI (Aly, Ogot and Pelz, 1995).

This category of problems is fraught with high-lying local minima. In order to reduce the premature termination of the optimization process in these regions of the design space, and increase the probability of converging to solutions which meet the above stated requirements, a new synthesis procedure for the synthesis of dwell mechanisms was developed. This procedure is detailed in Technical Working Paper (TWP) #108, attached as Appendix 4.3. Numerous candidate designs were determined which met all the above stated requirements except one, size. The design team therefore decided to investigate the utility of eight bar designs.

3.2.4 Synthesis of Eight-Link Designs

Due to the large size of the six link mechanisms previously synthesized to meet the specified design requirements, the design process shifted to the design of an eight-link mechanism (Figure 8). The use of the eight-link device provides the following benefits:

1. Increased number of links should provide superior dwell characteristics
2. By dividing the device into a six-bar and slider crank (dotted line in Figure 8) two syntheses can be carried out. The first one is to design a six bar, with rotary output. The mechanism should have an output range of 120° . The output link should travel from one limit position to the other (forward stroke) in 120° , dwell for 120° and return in 120° . The output link of the six bar corresponds to the input link of the slider crank. Since our concern here is maintaining an ANGULAR output displacement, symmetrical reduction/enlargement of the link lengths will not affect the output as was the case with the six-bar with slider output.

Once a six-link mechanism with an appropriate angular output and dwell characteristics has been synthesized, it can be contracted to meet size requirements. The output from the six bar, is

then attached to the input of a slider crank. Note that the slider cranks requirements are 120° input rotation producing stroke lengths of 4" and 7", corresponding to piston 1 and 2, respectively of the pouch feeding mechanism.

The first task was the design of the appropriate six-bar mechanism which would have rotary output range of 120°. The output link should travel from one limit position to the other (forward stroke) in 120°, dwell for 120° and return in 120° of the input link rotation. The output link of the six bar corresponds to the input link of the slider crank, whose design will be detailed next. Once a six-link mechanism with appropriate angular output and dwell characteristics has been synthesized, it can be contracted to meet size requirements. The output from the six bar, is then attached to the input of a slider crank. Force transmission (quantified by mechanical advantage, a kinematic performance parameter) was also factored into the synthesis procedure, yielding a multi-objective problem, solved via SAWI. The design which yielded a mechanism that met the stated motion requirements and provided optimal transmission qualities was determined. The position of the six-link mechanism at it's initial position and at the dwell position are illustrated in Figures 9a and 9b. The actual output link profile vs. input angle and mechanical advantage vs. the same are plotted in Figure 10.

The next task was the synthesis of the two slider cranks which constitute pistons 1 and 2. Combination of the six-bars and the slider-crank with the appropriate synchronization will yield the guts of the required pouch feeding mechanism. Recall, that a rotation of the crank through 120° will produce the 4" and 7" stroke corresponding to piston 1 and 2, respectively, of the pouch feeding mechanism. The aim here was to design the slider crank which not only gave the desired stroke requirements, but had the maximum mechanical advantage, yet occupied the smallest area. Thus several objectives had to be met during the optimization process. The mechanism was synthesized using dyad synthesis (Erdman and Sandor, 1991) coupled with the optimization routine, SAWI.

The link lengths obtained for both slider cranks are presented in Table 2. Figure 11 shows the plot of the slider position during 1/2 cycle for piston 1. Also included therein is the mechanical advantage plot. Note that the mechanical advantage is always greater than one throughout the cycle, signifying good transmission qualities.

Based on these results, a three dimensional computational model for the complete mechanism was developed.

Figure 12 is a 2D model of the piston mechanism at each of the limit positions: the quick return stroke, and the dwell followed by slower forward stroke. This figure also serves to tie together the schematic of the "Dogger" filler concept and the link mechanism .

3.3 Concluding Remarks

This project sought to determine the feasibility of developing mechanisms to perform the task of feeding placeables into vertically oriented pouches. The constraint on the orientation of the pouches is due to the current use of vertical form/fill/seal machines. Several concepts were conceived and evaluated based on ease of construction, fulfillment of task, size, versatility and simplicity. The 'dogger' concept was deemed the most promising and therefore underwent further development. After establishing the motion requirements of the mechanism, first a two-

dimensional, and then computational solid model of the final mechanism were designed. Both illustrate the feasibility of using mechanisms to re-orient the placeables before inserting them into the pouches. Currently the procedure is done manually. This preliminary study leads us to the following recommendations:

1. In order to convert vertical form/fill/seal machines to be able to handle solid placeables, a relatively simple linkage-based device can be utilized. The use of a linkage type device, versus a robotic device, provides similar functionality at significant reduced cost. It is estimated that a fully functional system could be built for under \$20,000.
2. Construction of a prototype, based on the three dimensional computer models developed in this study, would yield valuable information on the system reliability, repeatability, maximum feed rates, containment of seal contamination, and the cost of operation and maintenance.

References

Aly, S., M. Ogot and R. Pelz (1995). "An Improved Simulated Annealing Algorithm" ASME Design Automation Conference, Boston, MA,

Erdman, A. and G. Sandor (1991). Mechanism Design: Analysis and Synthesis. Englewood Cliffs, NJ, Prentice-Hall, Inc.

Hall, A. S. J. (1981). Notes on Mechanism Analysis. Prospect Heights, IL, Waveland Press Inc.

Table 1. Decision Matrix for Selection of Final Design

	Speed	Size	Ease of Constr.	Versatility	Simplicity	Total
Ham-Slammer	0.56	0.78	0.67	0.39	0.53	0.57
Dogger	1	1	1	1	0.89	0.98
Conveyor	0.89	0.89	1	1	1	0.96
Drum	0.66	0.67	0.11	1	0.32	0.55
Weights	30%	5%	30%	20%	15%	100%

Table 2. Link Lengths of Slider Crank Producing 4" and 7" Strokes

	R1 (")	R2 (")	R3 (")	R4 (")
4"	2.16	2.70	1.88	-3.82
7"	3.78	4.73	3.29	6.69

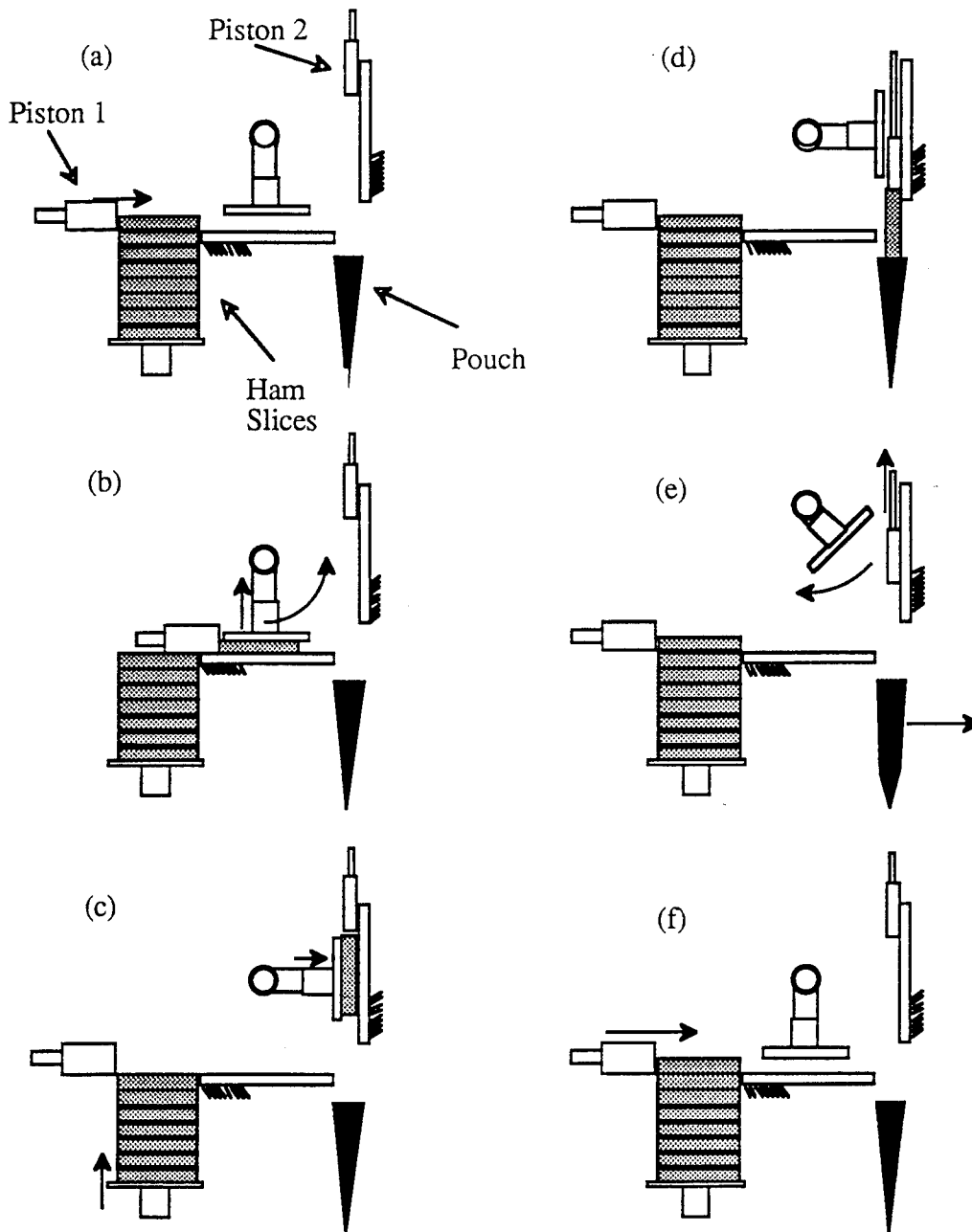

Figure 1 Schematic of Hamslammer Concept

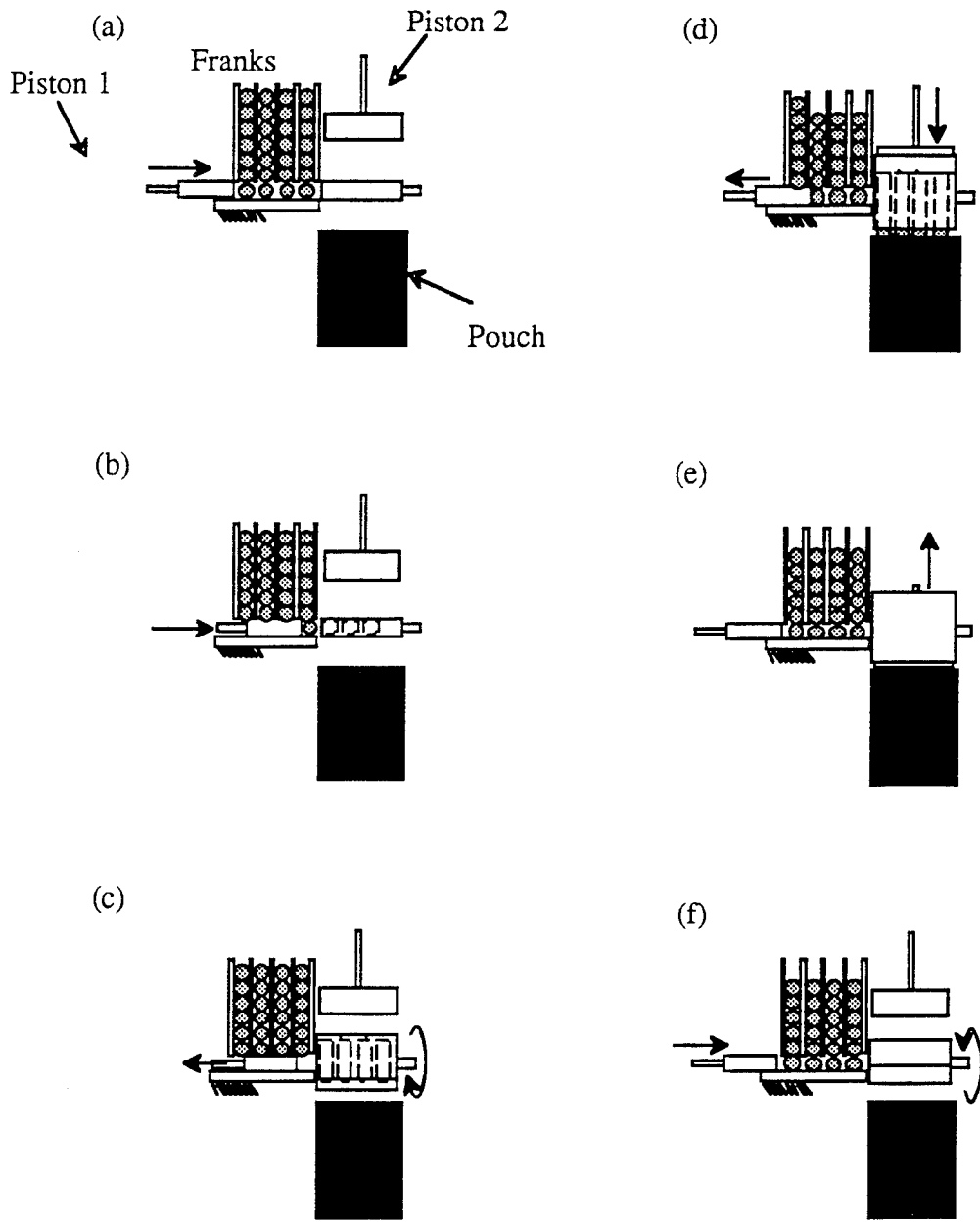

Figure 2 Schematic of Dogger Concept

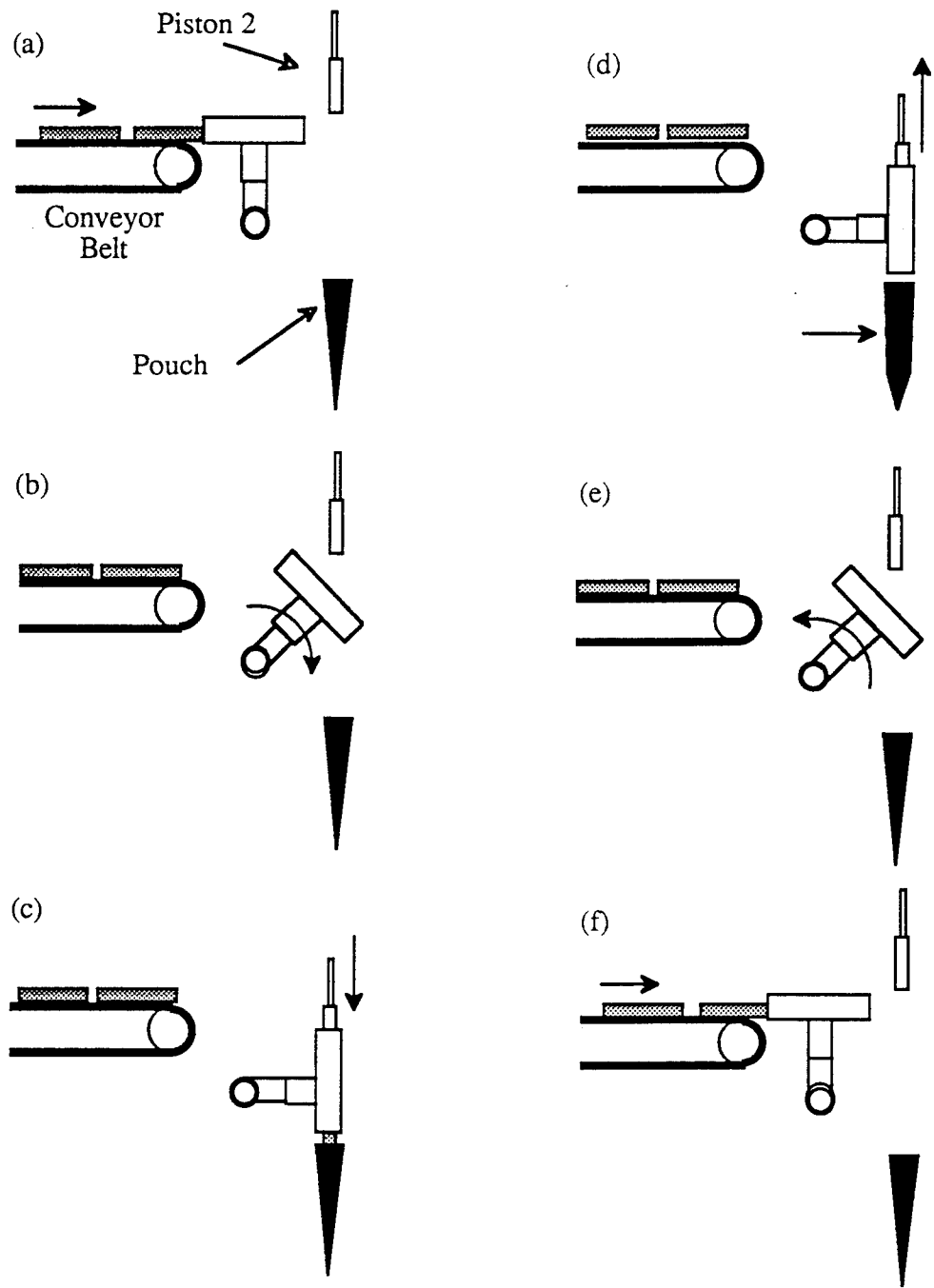

Figure 3 Schematic of Conveyor Concept

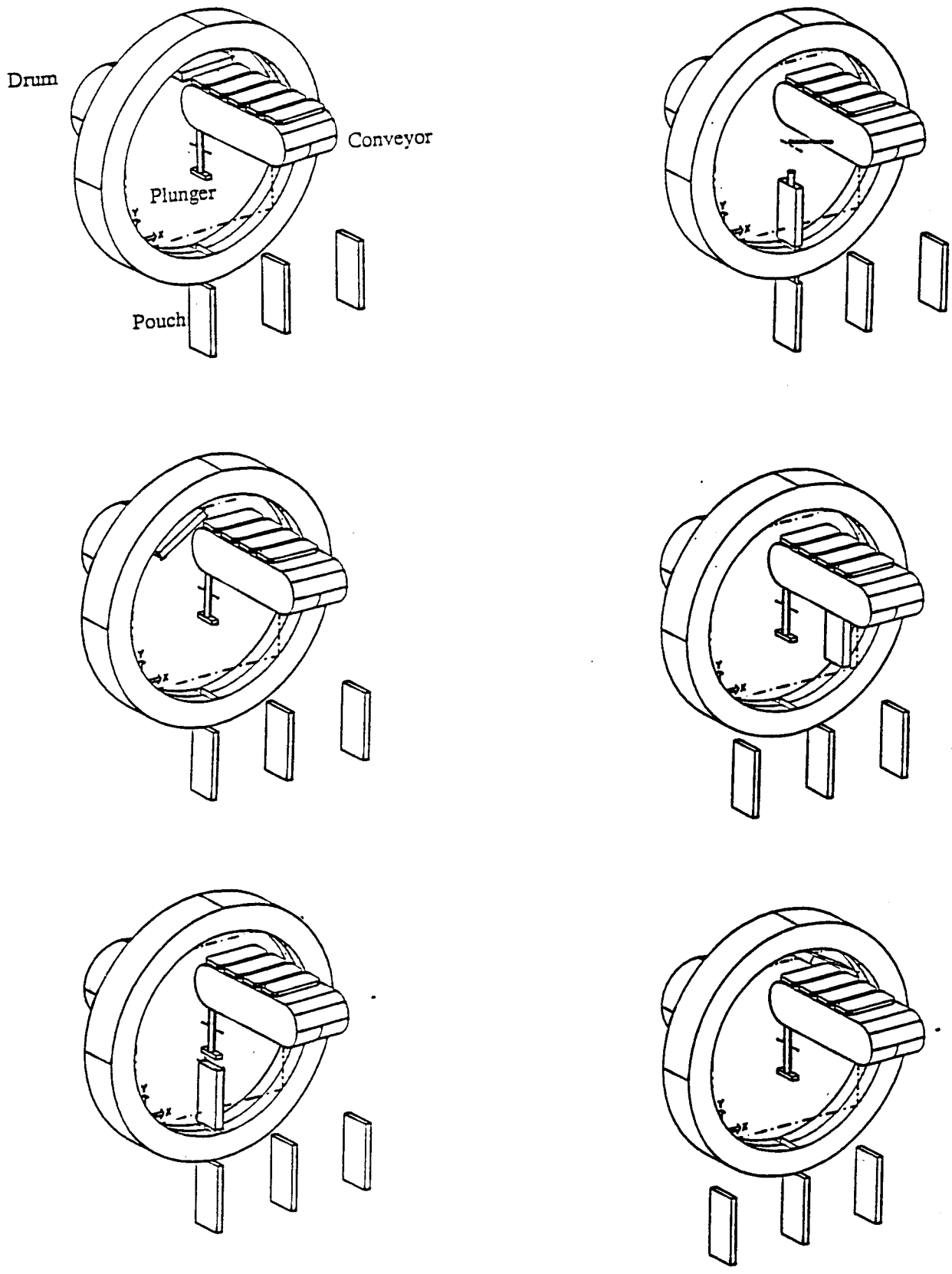

Figure 4 Schematic of Drum Assembly Concept at Different Stages of the Feed Cycle

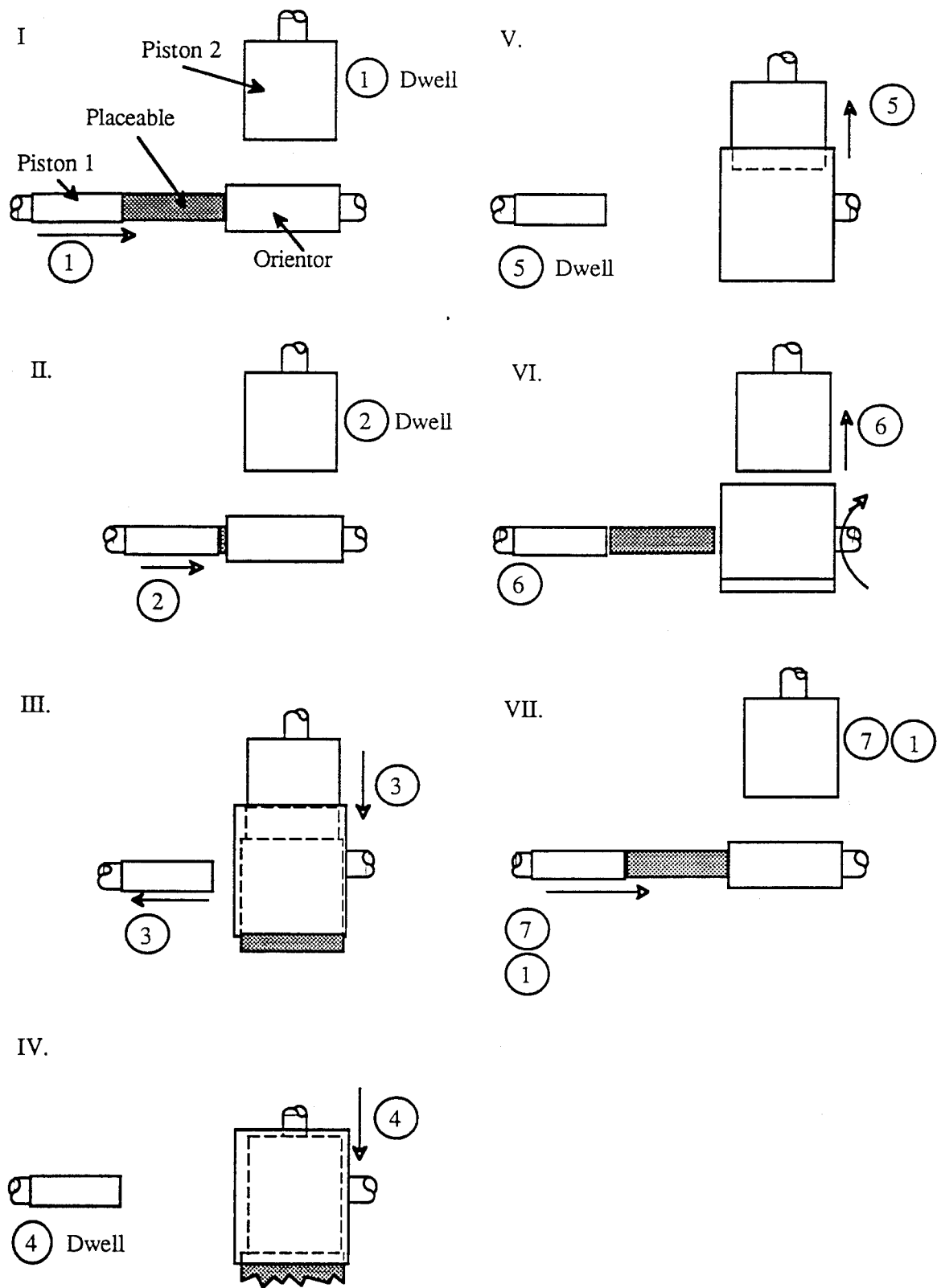

Figure 5 Sequencing of Motion of Three Components

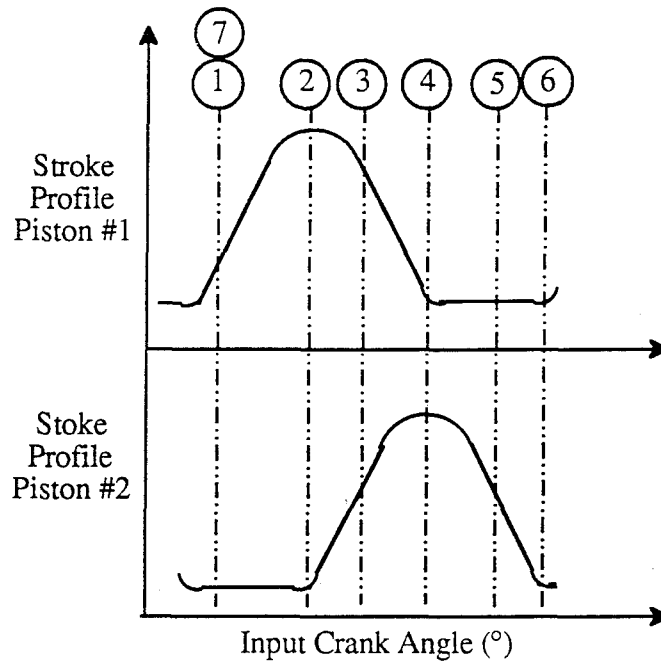

Figure 6. Stroke Profiles vs. Input Crank Angle for Piston #1 and Piston #2 Illustrating Required Sequencing

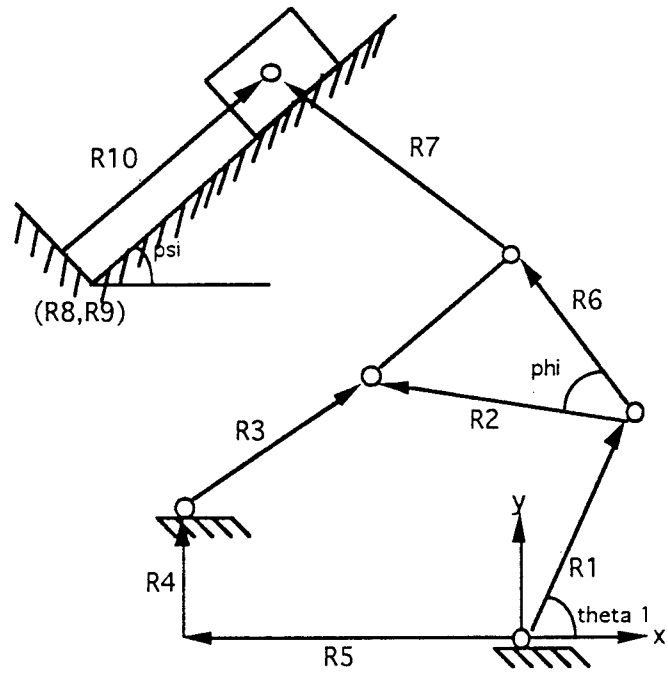

Figure 7. Six Link Mechanism Showing Definitions of Design Variables

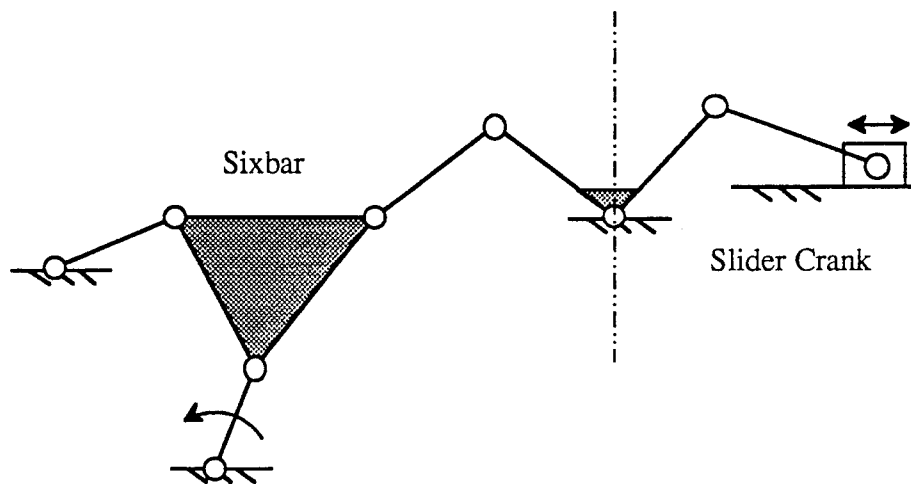

Figure 8. Eight Link Mechanism

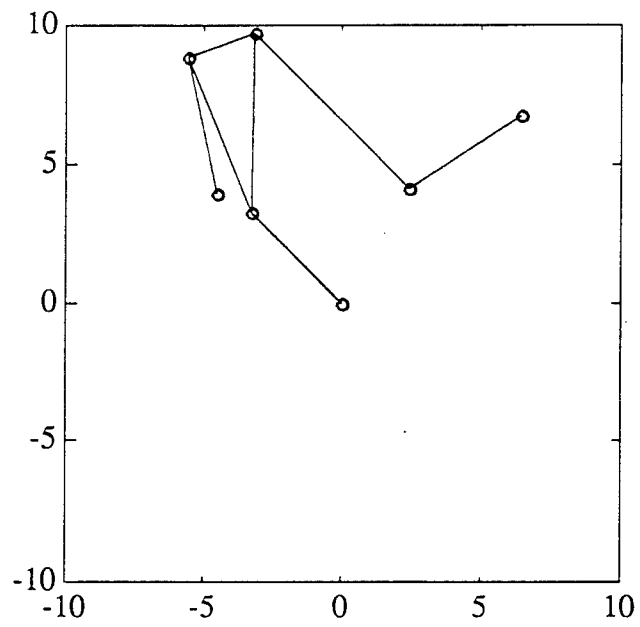

Figure 9a. Six-Link Mechanism at the Initial Position

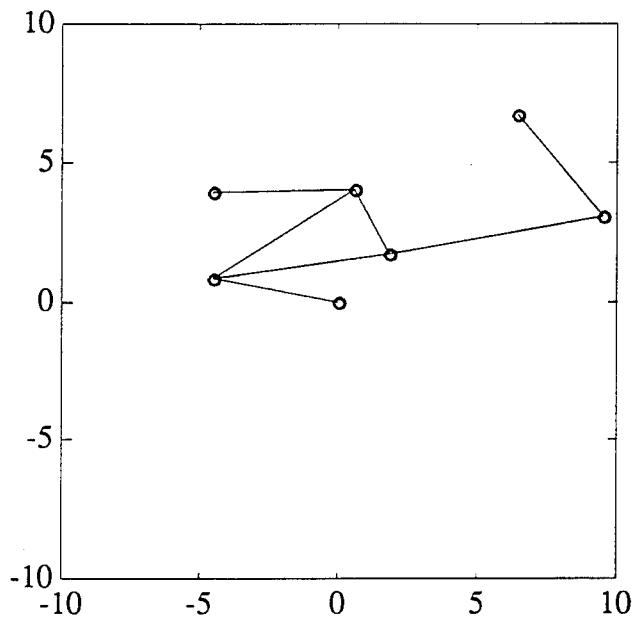

Figure 9b. Six Link Mechanism at the Dwell Position

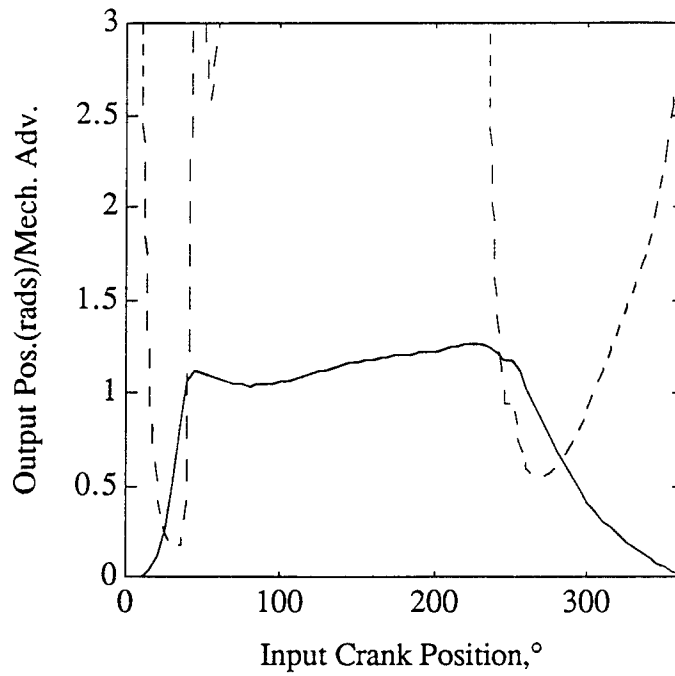

Figure 10. Position of Output Link(Solid) and Mechanical Advantage(Dashed) vs. Input Crank Angle for Six Link Mechanism

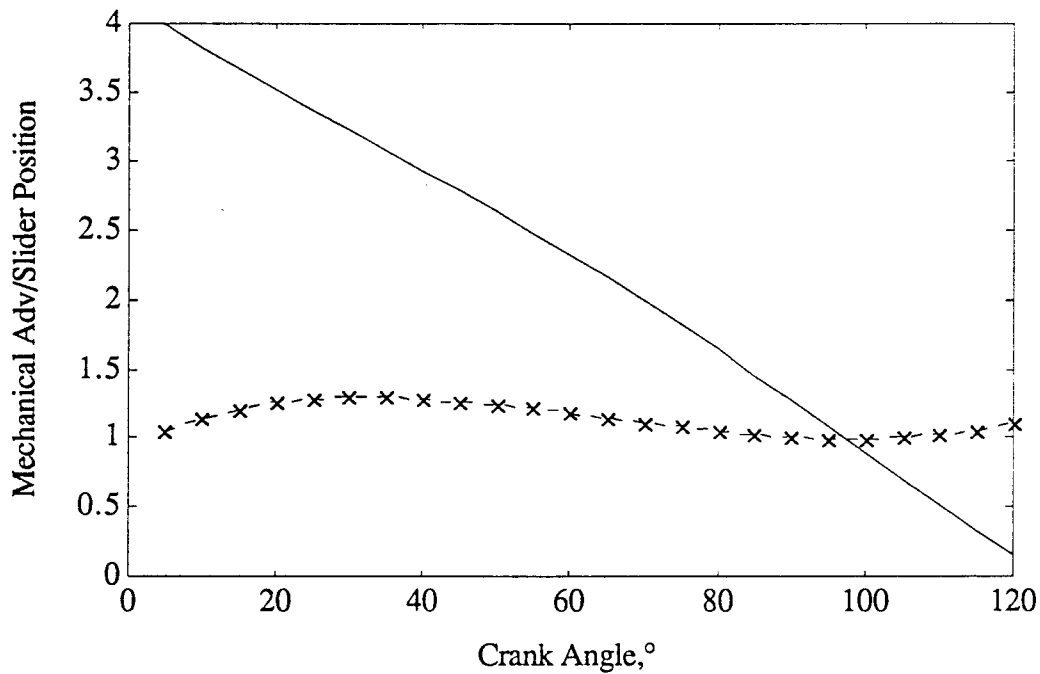

Figure 11. Slider Position (Solid) and Mechanical Advantage (Dashed) vs. Crank Angle for 4" Stroke

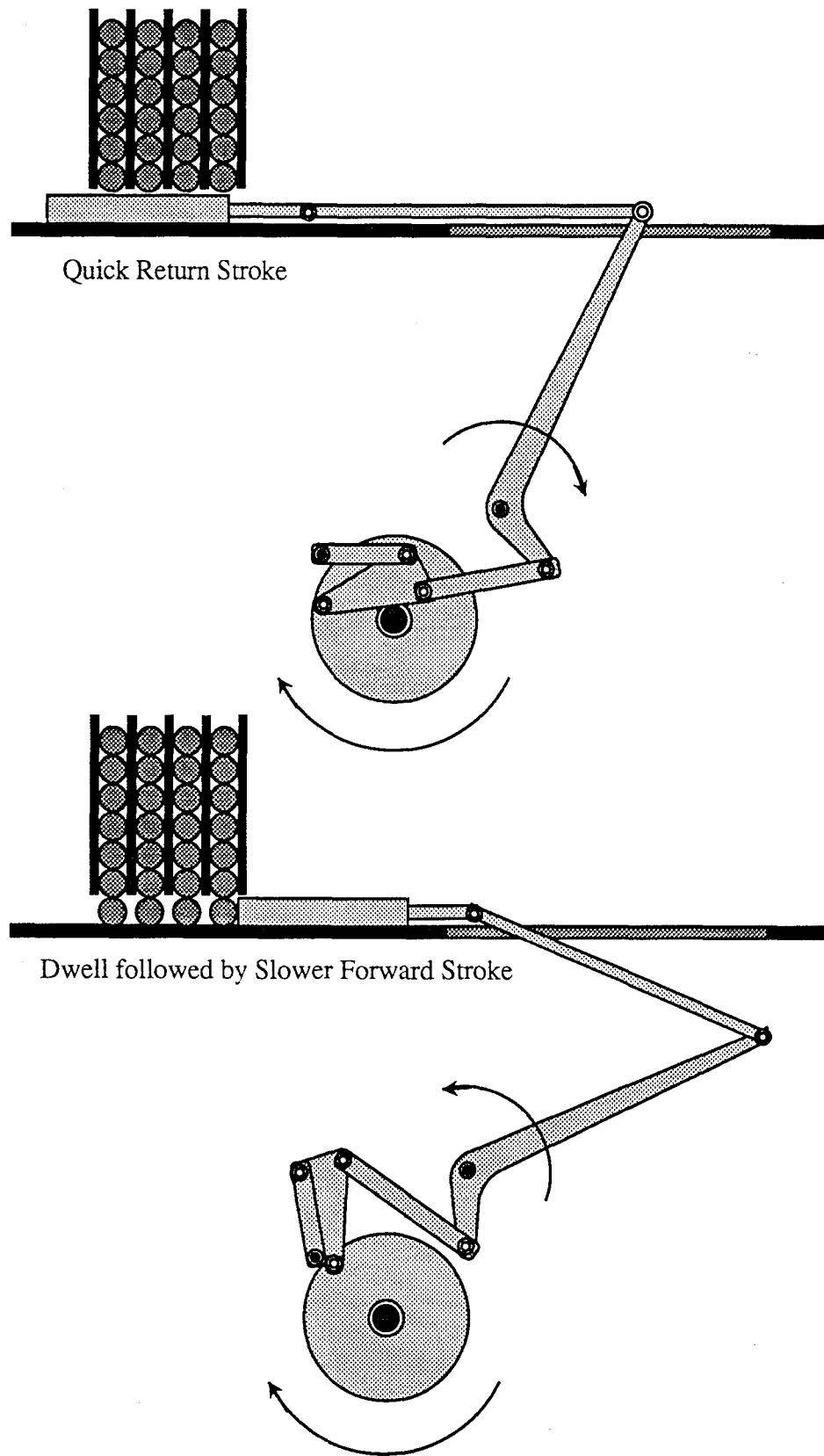

Figure 12. 2D Model of One of the Piston Mechanisms at each of the Limit Positions. A Similar Arrangement is Used for Piston 2.

4.0 Appendix

- 4.1 Figure 1 - CRAMTD FTR #15 Time and Events and Milestones
- 4.2 List of Patents Found to be Relevant to STP#15
- 4.3 Technical Working Paper (TWP) #108, "An Alternate Formulation of the Linkage-Type Dwell Mechanism Synthesis Problem", M.M. Ogot and S. Aly, February 1996.

4.2 List of Patents Found to be Relevant to STP# 15

<u>Patent No.</u>	<u>Author, Title</u>
3,426,941	Hovekamp, et al. 'Adjustable Vertical Feeder Means for Stacked Articles'
3,435,940	Seragnoli, 'Mechanism for Formation of Orderly Groups of Cigarettes'
3,480,159	White, F.F et al. 'Bar and Tube Feeder for Automatic Machines'
3,557,976	'Vertical Feeder for Magazine in Magazine Feed'
3,517,844	Wloszek, J.T. 'Feeder for Elongated bars or Tubes'
3,802,603	Gordon, 'Automatic Bar Loader or Feeder'
3,838,663	Focke, 'Light Shutter System for Detecting Blockages in a Cigarette Feeder'
3,938,697	Kinney 'Magazine Feeder for Circular Elements'
4,306,649	Berge, 'Rotary Feeder Mechanism for Fruit Juice Extracting Apparatus'
4,328,737	Nelson et al. 'Ammunition Feeder for a Gun'
4,382,575	Focke et al. 'Wedge Shaped Chute wall with Bent Ends for Cigarette Magazines'
4,397,216	Tassie, 'Feeder Mechanism'
4,403,908	Cartoceti, 'Method for the Emptying of Cigarette Trays into Magazines'
5,064,049	Saito, 'Device for lining up Parts'
5,072,872	Casset et al. 'Device for Transporting Materials in Strip, Sheet, or Filament Form'
5,104,002	Cahlander et al. 'Food Dispenser and Method'
5,127,511	Kean, Jr. et al. 'Methods and Apparatus for Feeding and Assembling Cylindrical Articles from Bulk at High Speed'
5,165,837	Schuppert, Jr. et al. 'Apparatus for Feeding Articles from Tube Magazines'
5,174,558	Sanborn, III 'Automatic Feeder for Workpieces of Limb Material'
5,248,058	Aoyama, 'Parts Feeder'
5,267,639	Amoh, 'Device for Continuously Feeding Kick Springs'
6,674,128	Mead, 'Feeder for Cylindrical Objects'

**Figure 1 - CRAMTD Short Term Project #15
Alternate Filling of MRE Placeables
Projected Time & Events and Milestones**

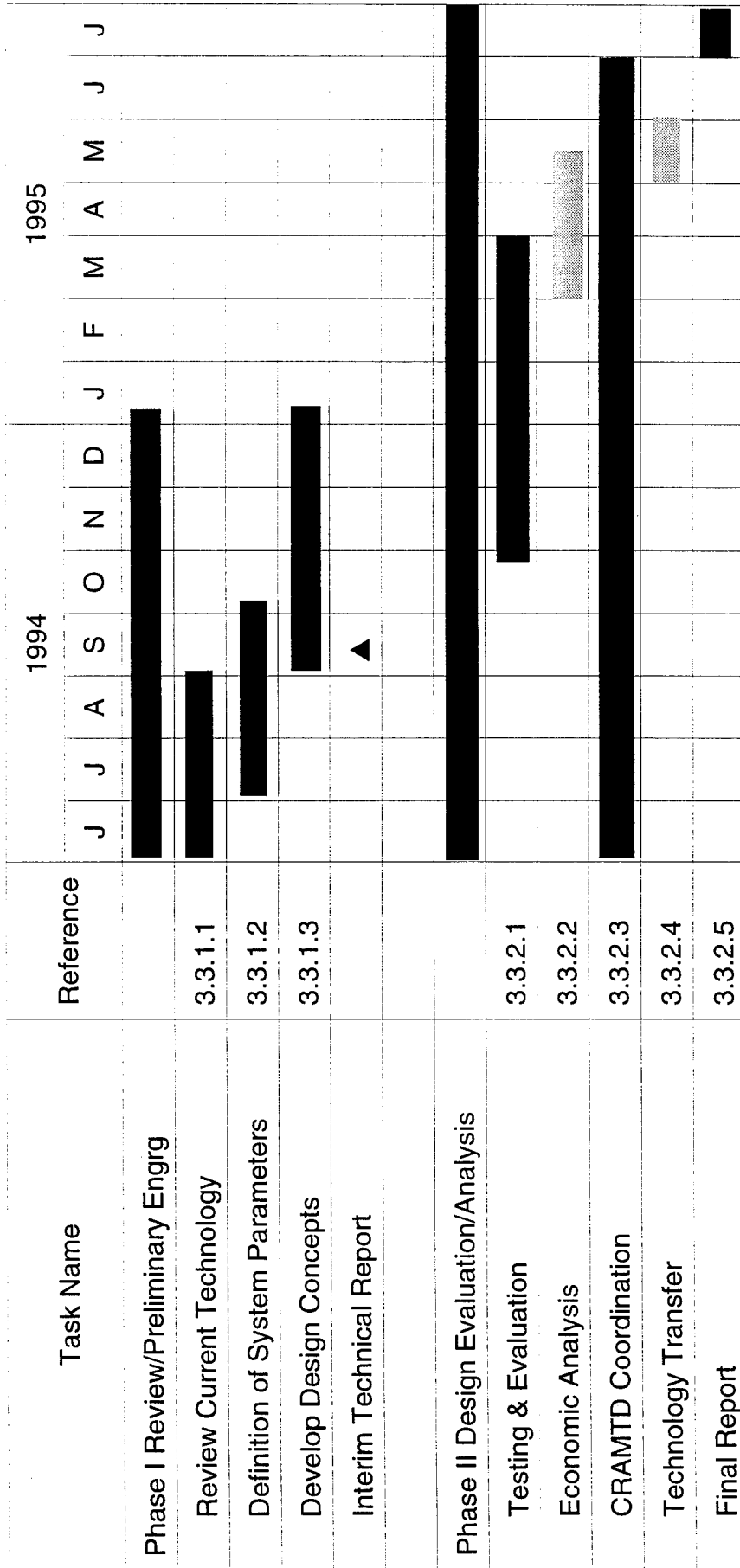

Printed: 02/14/96

**COMBAT RATION
ADVANCED MANUFACTURING
TECHNOLOGY DEMONSTRATION
(CRAMTD)**

**An Alternate Formulation of the Linkage-Type
Dwell Mechanism Synthesis Problem**

Technical Working Paper (TWP) 108

Madara M. Ogot and Sherif Aly

February 1996

Sponsored by:
DEFENSE LOGISTICS AGENCY
8725 John J. Kingman Rd.
Fort Belvoir, VA 22060-6221

Contractor:
Rutgers, The State University of New Jersey
THE CENTER FOR ADVANCED FOOD TECHNOLOGY*
Cook College
N.J. Agricultural Experiment Station
New Brunswick, New Jersey 08903

Dr. John F. Coburn
Program Director

TEL: 908-445-6132
FAX: 908-445-6145

An Alternative Formulation of the Linkage-Type Dwell Mechanism Synthesis Problem

Madara M. Ogot and Sherif Aly

Department of Mechanical and Aerospace Engineering

RUTGERS, The State University of New Jersey

Piscataway, New Jersey 08855

Voice:908 445 0504, Fax 908 445 5313, email: ogot@jove.rutgers.edu

ABSTRACT

Dwell mechanisms are utilized extensively in machine tools, packaging and textile machinery, and machines used for the closing and labeling of cans. For numerous applications, exact dwells are not required facilitating the use of linkage-type dwell mechanisms which produce approximate dwells. The advantages which these mechanisms provide over cams include lower maintenance and manufacturing costs, superior performance at high speeds and higher reliability. Despite these advantages, dwell linkages are more difficult to design. Current numeric optimization-based formulations which make use of precision points, often converge to high lying local minima or fail to converge to a solution at all, since the structural error-based objective functions are typically highly non-linear and multi-modal functions in a multi-dimensional design space. The purpose of this paper, therefore, is the presentation of an optimization-based method which addresses this problem. The redefinition of the structural error-based objective function about precision lines instead of precision points, results in a more efficient search of the design space for optimal solutions. Use of precision lines maps symmetrical points in the design space to one point, thereby effectively shrinking the design space without any loss of information. As a result, superior solutions can be attained without requiring more computational effort than current optimization-based methods. The approach is tailored to the synthesis of linkage-type mechanisms with slider outputs and relatively long dwells. Two examples, a six-bar with a single dwell and a six-bar with a double dwell, are presented to illustrate the efficacy of the proposed formulation.

INTRODUCTION

In a dwell mechanism, one or more links temporarily comes to rest while the input motion remains non-zero. Dwell mechanisms are used in machine tools, packaging and textile machinery, and machines utilized for the closing and labeling of cans. Cams and

followers are frequently utilized for this task due to their simplicity. However, they have problems of high cost and wear. For numerous applications, exact dwells are not required, thereby facilitating the use of linkage-type dwell mechanisms which produce approximate dwells. The advantages that these mechanisms provide over cams include lower maintenance and manufacturing costs, superior performance at high speeds and higher reliability. Despite these advantages, dwell linkages are more difficult to design than cam devices, and since they are relatively large for the output motion obtained, they are also difficult to package well [1-4]

The difficulty in the design of linkage-type dwell mechanisms has provided motivation for researchers over the years to develop novel synthesis approaches. Despite the success achieved thus far, these formulations remain very restrictive, making it difficult to obtain mechanisms which meet all of the specified design requirements. The proposed formulation facilitates the synthesis of linkage-type dwell mechanisms with relatively long dwells. Specification of precision lines instead of points results in a more efficient search of the design space, yielding superior designs.

The next section presents previous approaches to the synthesis of linkage-type dwell mechanisms. This is followed by a discussion of the proposed formulation. Two examples, synthesis of a single dwell and a double dwell mechanism, are then presented to illustrate the efficacy of the proposed formulation. Finally, the paper concludes with a few closing remarks.

BACKGROUND ON SYNTHESIS OF LINKAGE-TYPE DWELL MECHANISMS

Previous approaches to the synthesis of linkage-type dwell mechanisms fall into four broad categories: coupler curve matching, precision point synthesis methods, analytical approaches, and optimization approaches. In coupler curve matching, a part of the mechanism to which the output links are attached is designed to match either a circular portion of an arc or a straight line. This results in the output link becoming motionless or dwelling. A coupler curve atlas is required for this approach [2,3]. In order to alleviate the tedium of searching through catalogs of coupler curves, several researchers have developed techniques to automate the process [5-10]. Research in this area is still on going to develop more efficient methods for representing, classifying and comparing the curves [11].

Other investigators have pursued analytical formulations. Here, analytical expressions are formulated for the output motion based on the system parameters. By setting one or

more of their derivatives with respect to the input displacement to zero and solving, yields the dimensions defining the required linkage [1, 12,13].

A variation from the above formulations are methods based on the use of precision points, where several (typically no more than five) precision points are specified. One of the numerous available analytical or numeric synthesis methods is then applied to design a mechanism whose output link will pass exactly through these points (refer to Figure 1a). Appropriate placement of the precision points defines the location, duration and stroke length of the dwell. Within the figure S , r and d represent the desired stroke, rise time (as a function of input position) and dwell duration, respectively. The initial position of the input link, Θ_i , is typically an unknown. Researchers who have pursued this approach include [14-18]. Although the synthesized mechanism may satisfy the dwell requirements at the precision points, there is no control over its behavior between the points. Furthermore, only a small number of precision points can be specified.

In an attempt to alleviate this problem and take advantage of the rapid improvement in computer technology, optimization-based methods have become increasingly popular. For example in Figure 1b, an arbitrary number of precision points are specified to define the dwell characteristics. These mechanisms do not need to satisfy the dwell requirements at the precision points exactly. Instead, an objective function based on the structural error, the difference between the precision point location and the actual output link location, can be defined as:

$$f(\mathbf{x}) = \frac{1}{n} \left\{ \sum_{i=1}^n (s_{di} - s_{ai})^2 \right\}^{0.5} \quad (1)$$

where \mathbf{x} , s_{di} , s_{ai} and n are the design variable vector, the desired and actual position of the output link at the i^{th} precision point, and the total number of precision points, respectively. By minimizing (1), the output of the synthesized mechanism approaches the desired dwell. Researchers who have pursued variations of this approach include [19,20]

Despite the improvement that these approaches provide over pure precision point methods, they have still achieved only limited success. In order to obtain reasonable results, the optimization process must be initiated at a 'good' starting point to avoid convergence to high-lying local minima. In addition, they often fail to converge to a final solution since the objective function is a highly non-linear and multi-modal function in a multi-dimensional design space[21]

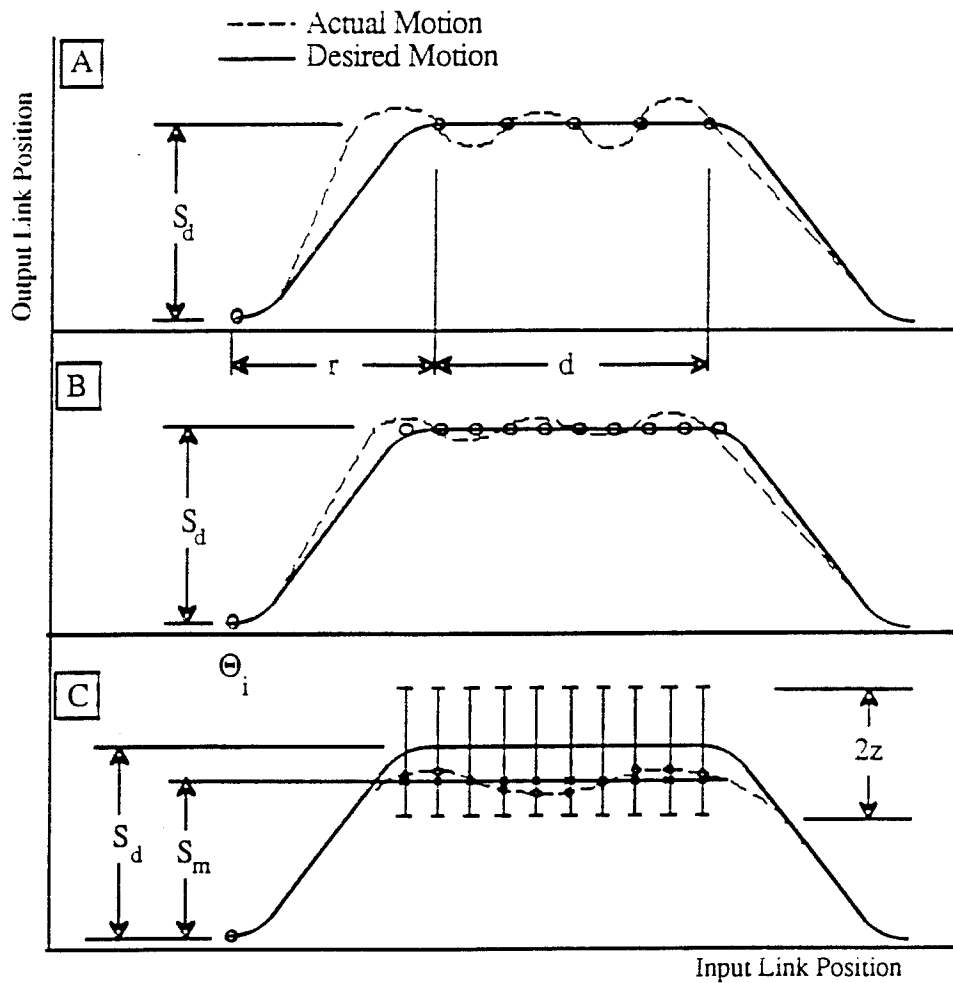

Figure 1. Comparison of (a) Precision Point, (b) Optimization and (c) Precision Line Approaches to Synthesis of Linkage-Type Dwell Mechanisms

The purpose of this paper, therefore, is the presentation of an optimization-based method which addresses some of the problems enumerated above. The redefinition of the structural error-based objective function about precision lines instead of precision points, results in a more efficient search of the design space for optimal solutions. Use of precision lines maps similar points in the design space to one point, thereby effectively shrinking the design space without any loss of information. As a result, superior solutions can be attained with the same level of effort as current optimization-based methods. The approach is tailored to the synthesis of linkage-type mechanisms with slider outputs and relatively long dwells.

THE PRECISION LINE APPROACH

Consider a desired dwell defined by the precision points (circles) in Figure 2. Assume that during the synthesis process, one of the intermediate designs produces a dwell defined

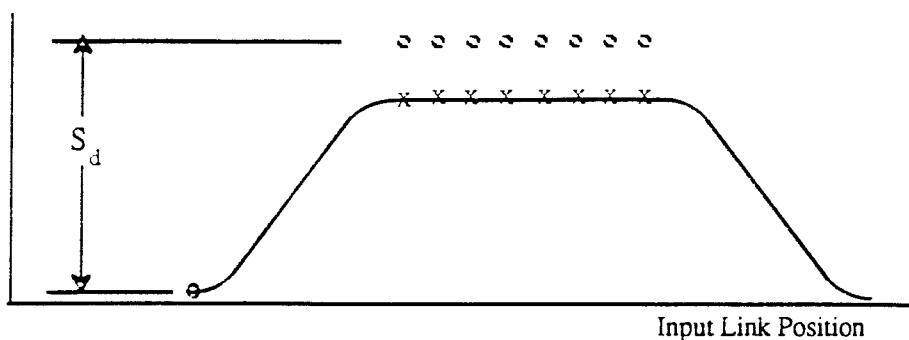

Figure 2. Basic Concept Behind the Precision Line Formulation

by the solid line in the same figure. Based on the formulation described in (1), the magnitude of the objective function would be quite large, and the optimization path would move away from this point in the design space. However, if the precision points were defined by the crosses, the objective function value would be at a near-optimal solution. These points would yield a mechanism with two of the desired dwell characteristics: dwell duration and timing. Although the stroke length requirement is not met, it can be achieved by enlarging the entire mechanism. Since the rise time and dwell duration are invariant to scaling, they would remain unaffected. This basic concept underlies the proposed formulation and can be achieved by employing precision lines in place of precision points, thereby making it possible to consider solutions which would previously have been discarded.

Single Dwell Formulation

Instead of defining the dwell characteristics via a set of fixed precision points, precision lines are specified (refer to Figure 1c). Precision lines have a length of $2z$ and are centered about the desired stroke length location¹. The length, z , is specified as a percentage of the desired stroke length, S_d . The precision lines define the dwell rise time and duration, but not the desired stroke length. At each iteration of the optimization process, the points which define the actual position of the output slider, S_i , are located at the intersection of the slider path curve and the precision lines (shown as diamonds in Figure 1c). The mean location of these points, or simply the mean location of the output link relative to its initial position, is the line of zero slope which best fits through these points in the least squared sense. The location of this line, S_m , is defined as:

¹Essentially, they are centered about where the conventional precision points would be placed to define stroke length.

$$S_m = \frac{1}{n_d} \sum_{i=1}^{n_d} S_i \quad (2)$$

where n_d is the number of precision lines which define the dwell duration. The intersections of the mean line and the precision lines locate the 'floating' precision points. S_i (shown as squares in Figure 1c). The modified structural error-based objective function, therefore, takes on the form of:

$$f(x) = \frac{1}{n_d} \left\{ \sum_{i=1}^{n_d} (S_m - S_i)^2 \right\}^{0.5} \quad (3)$$

If the mean line lies above or below the precision lines, then it is placed at the nearest boundary, i.e.

$$S_m = \begin{cases} S_d + z & S_m > S_d + z \\ \frac{1}{n_d} \sum_{i=1}^{n_d} S_i & \\ S_d - z & S_m < S_d - z \end{cases} \quad (4)$$

Scale Factors-Single Dwell

Multiplying all the synthesized linkage's link lengths by a scale factor, f_c , will alter the stroke length by the same proportion. Neither the dwell duration nor the rise time, however, are affected. In order for the linkage to produce the desired stroke length, S_d , from an intermediate design, S_m , the scale factor f_c must have the value

$$f_c = S_d / S_m \quad (5)$$

It is important to note that the structural error in the modified design will also have changed by the same proportion. Since the aim is to minimize the structural error of the adjusted mechanisms, the scale factor must be incorporated directly into the objective function defined in (3), yielding:

$$f(x) = \frac{f_c}{n_d} \left\{ \sum_{i=1}^{n_d} (S_m - s_i)^2 \right\}^{0.5} \quad (6)$$

Constraints-Single Dwell

The constraints on the problem are other design and functionality requirements which the final mechanism must meet. These include size, force-transmission, branching and mechanical advantage. Directly linked to the proposed formulation, the constraints are placed on the design variables, typically link lengths and orientations. Since orientations are invariant to scaling, their user-specified constraints are not affected. The constraints placed on the link lengths, however, are influenced and may end up exceeding their prescribed limits. In order to prevent this, the constraints on each link dimension are redefined as:

$$\frac{x_{li}}{1 - z} \leq x_i \leq \frac{x_{hi}}{1 + z} \quad (7)$$

where x_{li} and x_{hi} are the prescribed lower and upper bound of the i^{th} link dimension, respectively and z is half the length of the precision line.

Design Space Shrinkage - Line to Point Mapping

This section illustrates the line to point mapping achieved via the use of precision lines. This facilitates a more efficient search of the design space for optimal and near-optimal solutions. Let x and y be the two design variables of the linkage-type dwell mechanism synthesis problem whose design space is depicted by the solid box in Figure 3a. The lower bounds of the space are defined by x_l and y_l , and the upper bounds by x_h and y_h . Assume the optimal solution is located at (x_o, y_o) . Consider a line segment, AB, defined by the line which passes through both the origin and the optimal point, and bounded by the feasible design space. Any point (x_i, y_i) on the line segment will have the same ratio x/y . Subsequently any point on the line can be translated to the optimal point, (x_o, y_o) , via multiplication by some scale factor, f_c .

The effect of this translation on the dwell mechanism defined by (x_i, y_i) , would be an enlargement or reduction in size of the link lengths by the same scale factor f_c , and an adjustment of the mean stroke length to the desired stroke length. The dwell timing and duration would be unaffected. This means that by finding ANY design defined by a point located on the line segment AB, the BEST design on that line segment which satisfies all specified dwell characteristics can be determined without any further analysis by a simple translation in the design space. In other words, by determining the scale factor that adjusts the stroke length to the desired stroke length, the best design on line AB can be obtained.

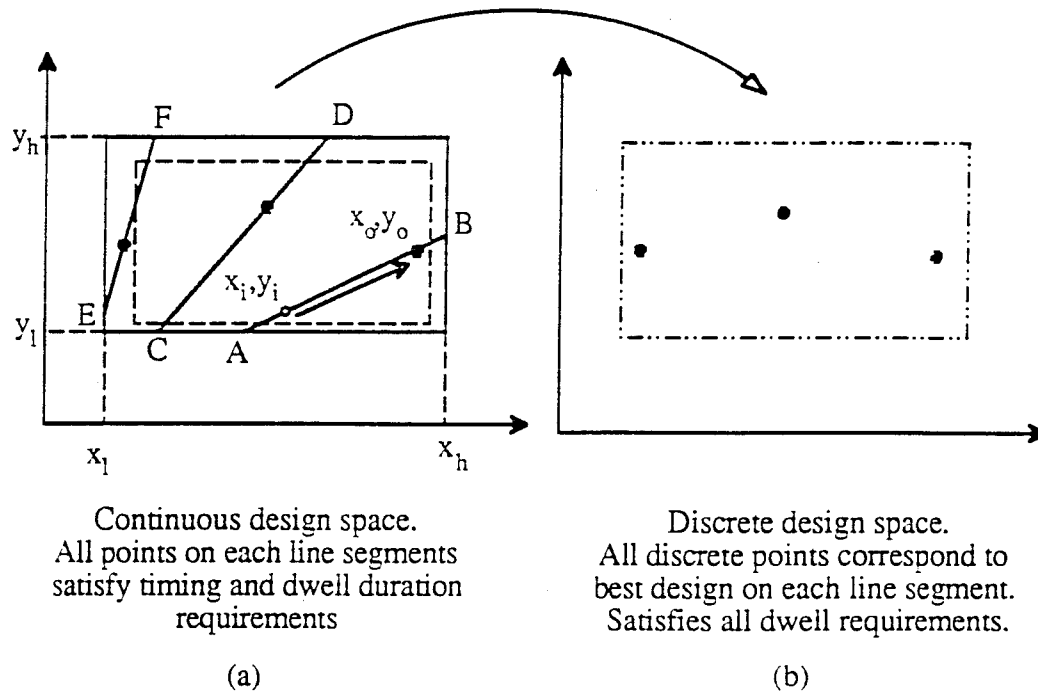

Figure 3. Line-to-Point Mapping. Effective Shrinkage of Design Space

All translated designs will have the same structural error or objective function value at (x_o, y_o) .

The feasible domain can therefore be defined as a collection of bounded line segments (for example, AB, CD and EF in Figure 3a). These lines, if unbounded, would pass through the origin, thereby ensuring a constant ratio between the variables along the line segment. Since all points on each line segment can readily be translated to the position on the line which yields the best solution (refer to Figure 3a), each line segment is effectively mapped to that single point. This yields a collection of points (refer to Figure 3b) in the new discrete design space. This line to point mapping effectively reduces the design space, without loss of information. With the current precision points formulation, the optimization routine would have to uniquely locate the optimal point (x_o, y_o) . With the proposed formulation, the routine merely has to find any point on the line segment AB. Furthermore, the location and translation of points on line segments 'close' to AB would directly yield near-optimal solutions. The proposed formulation therefore takes full advantage of the symmetry lines in the design space.

The modified constraints placed on the link length design variables defined in (7), result in the loss of some information and the possible inaccessibility of an optimal region in the design space. This can be seen in Figure 3a, where the dashed box represents the modified bounded design space. The inaccessibility of these regions of the design space occurs only

if an entire line segment lies outside the modified bounded design space. For example, the best point on the line segment EF lies outside the dashed box in Figure 3a. But if the optimizer locates any point on the portion of EF that lies within the modified design space, that point can still be translated to the best point on EF, where the dimensions of the scaled mechanism would not violate the original specified dimensional constraints. The discussion in this section has focused on a two design variable problem merely to facilitate easy visualization. The same arguments and line to point mappings are equally applicable in n-dimensional space for a synthesis problem with n design variables.

Formulation for a Double Dwell Mechanism

The presence of two dwell regions in a double dwell mechanism, necessitates the definition of two precision line sets (refer to Figure 4). The lowest point in the output curve (point 0 in Figure 4) serves as the zero reference from which the location of the lower and upper mean stroke lines are defined (S_{lm} and S_{hm} , respectively). The structural error-based objective function in (6) can be rewritten as

$$\text{obj} = \frac{f_c'}{n} \left\{ \sum_{i=1}^{n_1} (S_{lm} - S_i)^2 + \sum_{i=n_1+1}^n (S_{hm} - S_i)^2 \right\}^{0.5} \quad (8)$$

where n_1 is the number of precision points in the lower dwell, n is the total number of floating precision points, and S_i is the actual slider location. The actual mean stroke is now specified by the difference between S_{lm} and S_{hm} . The modified scale factor, f_c' , therefore becomes:

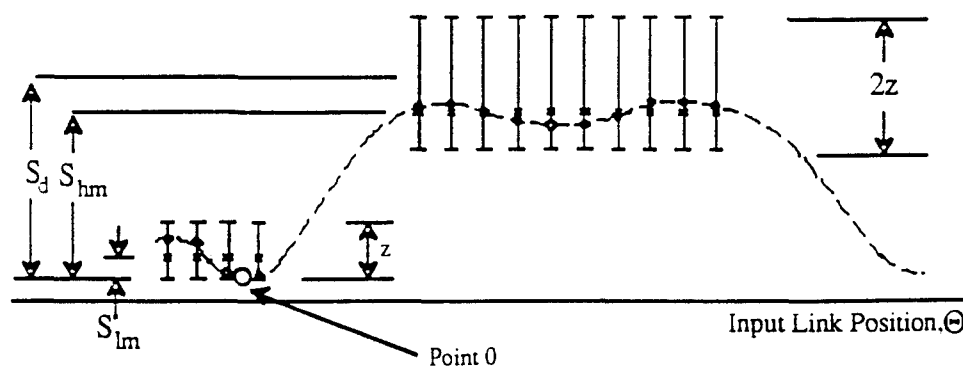

Figure 4. Precision Line Formulation for Double Dwell Mechanism

$$f_c' = \left\{ \frac{S_d}{S_{hm} - S_{lm}} \right\} \quad (9)$$

Finally, in order to ensure that the scaled mechanisms link lengths do not exceed their initial prescribed constraints, the latter are adjusted taking on the form

$$\frac{x_{li}}{1 - z} \leq x_i \leq \frac{x_{hi}}{1 + 2z} \quad (10)$$

Recall that only the constraints on the link length dimensions are affected, as the angular dimensions are not scaled during the entire design process.

EXAMPLES

Two examples are presented to illustrate the efficacy of the proposed formulation. The first example illustrates the approach for the design of a six-bar linkage with a single dwell. The second example illustrates the approach for the synthesis of a six-bar with a double dwell. For both examples, a parametric study is carried out on the effect of the precision line length on the quality of the final solution. The length, z , is varied from 0.0 (corresponding to current precision point formulation) to 0.3 S_d (30% of the desired stroke length). Statistics on the quality of solution and the number of iterations required are compared. Due to the highly non-linear, multi-modal nature of the objective function, a stochastic optimization method, Simulated Annealing With random search Iterative improvement (SAWI) is used [22]. The algorithm, a modified version of simulated annealing (SA) essentially initiates the SA process to locate the general neighborhood an optimum. Prior to the convergence, SA is prematurely terminated and the algorithm switches to a random search iterative improvement method to converge to the optimum, thereby significantly reducing the computation time as compared to pure SA.

Due to the probabilistic nature of stochastic methods, however, distinct answers will be obtained each time they are run, i.e. different seed values for the random number generator will yield disparate results. In order to perform an equitable comparison during the parametric analysis, ten optimization runs are performed at each value of z , ensuring ten distinct initial points and optimization paths in the design space. The average optimal solution of the ten runs at each z value are subsequently used for comparison.

Single Dwell Example

The aim of this example is to synthesize a six-bar with an approximate, relatively long, single dwell (refer to Figure 5). The desired stroke length should be 4" long with a rise

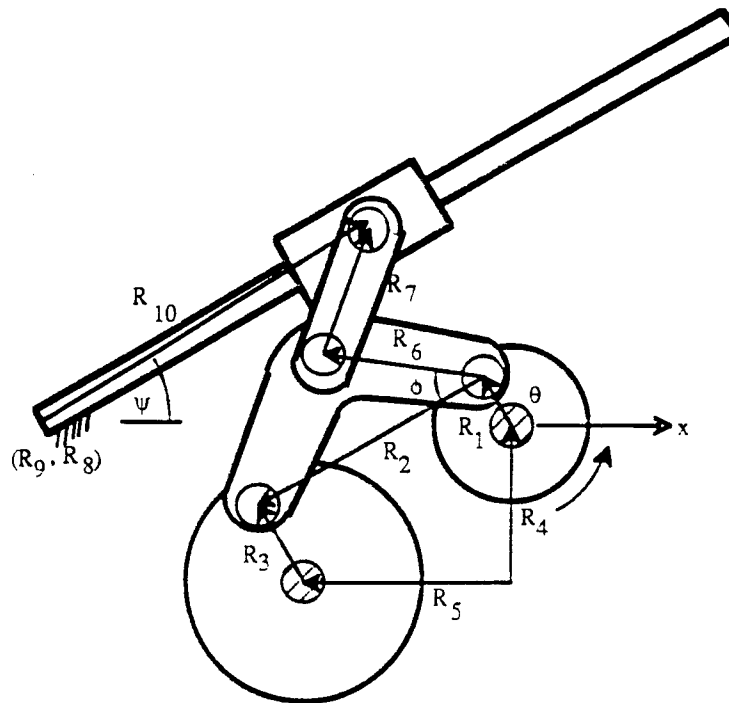

Figure 5. Six-Bar Linkage w/ Translational Output

Table 1. Limits Placed on Design Variables for Both Single and Double-Dwell Examples Unless Noted Otherwise, all Units are Inches

	R_1	R_2	R_3	R_4	R_5	R_6	R_7	R_8	R_9	ψ°	ϕ°
Hi	5	10	10	10	10	10	10	10	10	90	90
Low	1.0	0.5	3	0.5	0.5	0.5	0.5	-10	-10	-90	5

time and dwell duration of 180° and 120° respectively. Thirteen precision lines, spaced 10° degrees apart are used to define the dwell, and one precision point defines the stroke. The design variables are the link lengths $R_1, R_2, R_3, R_4, R_5,$ and R_7 ; R_6 and ϕ which specify the coupler point; and R_8, R_9 and ψ which define the slider path for a total of 11. The limits placed on the design variables are listed in Table 1.

Figure 6 displays the mean data from each of the 10 runs performed at z equals 0.0 to $0.30 S_d$ at intervals of $0.05 S_d$. Recall that $z=0.0$ corresponds to current precision point formulation as defined in (1). The mean average structural error has been reduced from $0.055''$ at $z=0$, to $0.025''$ at $z=0.2 S_d$, a 54% reduction. The best results from $z=0.0$ and $z=0.2 S_d$ are $0.0239''$ and $0.0023''$, respectively, reflecting a 90% reduction in structural error through the proposed precision line formulation. The design variable set $\{R_1, R_2, R_3, R_4, R_5, R_6, R_7, R_8, R_9, \psi, \phi\}$, for the latter design takes on the values of $\{1.7229''$,

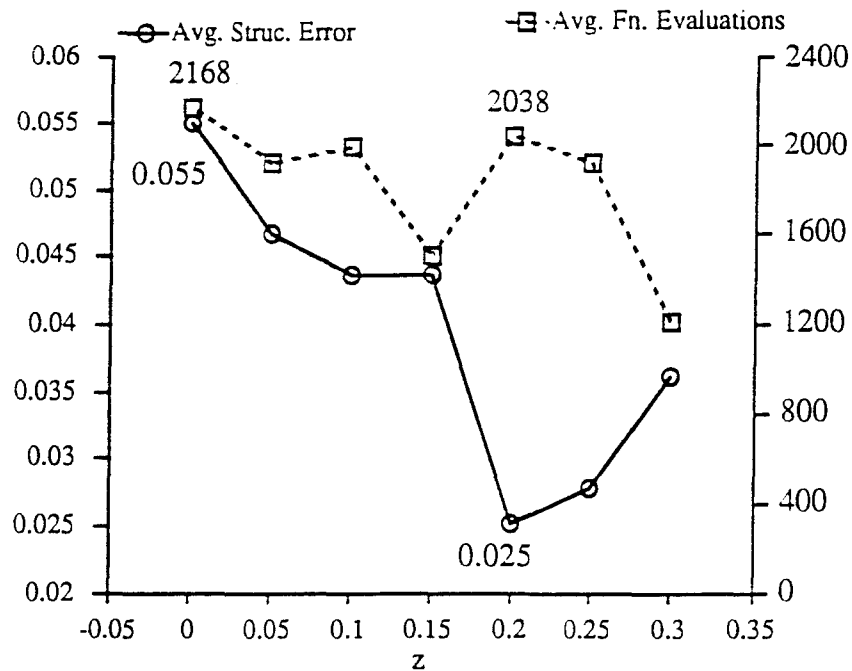

Figure 6. Mean Average Structural Error and Number of Function Evaluations for the Ten Runs at each Tolerance Zone Value, Single-Dwell Example

3.4887", 4.9638", 2.9875", 1.25425", 3.99291", 7.00886", -10.7008", -5.41385", 17.5°, 27.9°}.

As z is increased beyond $0.2S_d$, there is a deterioration in the quality of solution. This is probably due to the reduction in the design space and subsequent loss of information as depicted by the dashed box in Figure 4. This deterioration suggests that the benefits obtained from employing precision lines begins to be overcome by the negative effects of the reduced design space. The number of function evaluations performed is representative of the computation time. For this example, the number of function evaluations had a modest decrease from 2168 at $z=0.0$, to 2038 at $z=0.2S_d$, a 6 % reduction. The important point to note here is not the modest reduction in computation time, but the ability to obtain superior solutions without requiring additional computation time. The path of the best solution found at $z=0.2S_d$ is illustrated in Figure 7. The circles in this figure locate the floating precision point locations.

Double-Dwell Example

The aim of this example is to illustrate the applicability of the proposed precision line formulation to the synthesis of a linkage-type mechanism with two relatively long dwells.

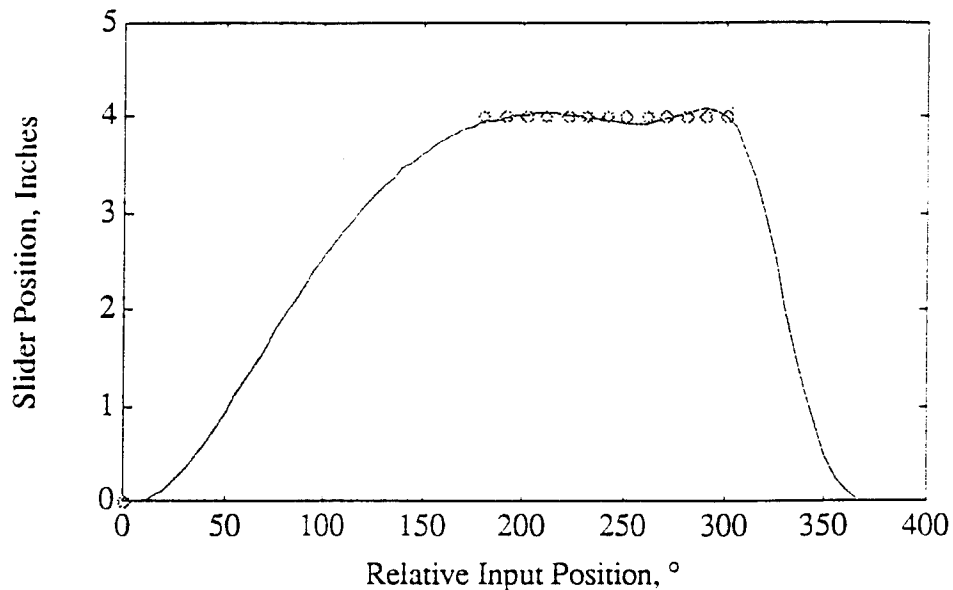

Figure 7. Representative Path of Slider Obtained at $z=0.2$. The Circles Correspond to the Position of the Precision Points, Single-Dwell Example

Employing the same six-bar as the previous example, a double-dwell mechanism with a stroke of 4" is required. The first dwell should have a duration of 40° defined by five precision lines spaced 10° degrees apart. After a 130° rise time, the second dwell should have a duration of 80° defined by 9 precision lines, also spaced 10° apart, for a total of 14 lines. The mean value of the ten runs at each z value is given in Figure 8. The mean average structural error at each precision point has been reduced from 0.039" at $z=0.0$, to 0.023" at $z=0.25S_d$, a 41% reduction. The best results from $z=0.0$ and $z=0.25S_d$ are 0.034" and 0.0114", respectively, reflecting a 66% reduction in structural error via the proposed precision line formulation. The design variable set, $\{R_1, R_2, R_3, R_4, R_5, R_6, R_7, R_8, R_9, \psi, \phi\}$, for the latter design takes on the values of $\{2.944", 4.703", 4.720", 5.595", 1.436", 5.312", 5.885", -7.110", -8.861", 43.5^\circ, 7.566^\circ\}$. The average number of function evaluations, representative of the average computation time, is presented within the same figure. The modest 13 % decrease in computation time from $z=0.0$ to $z=0.25S_d$, again demonstrates that the precision line approach can yield superior solutions without requiring more computational effort. The slider path of the best solution found at $z=0.25S_d$ is illustrated in Figure 9. The circles in the figure locate the floating precision point locations.

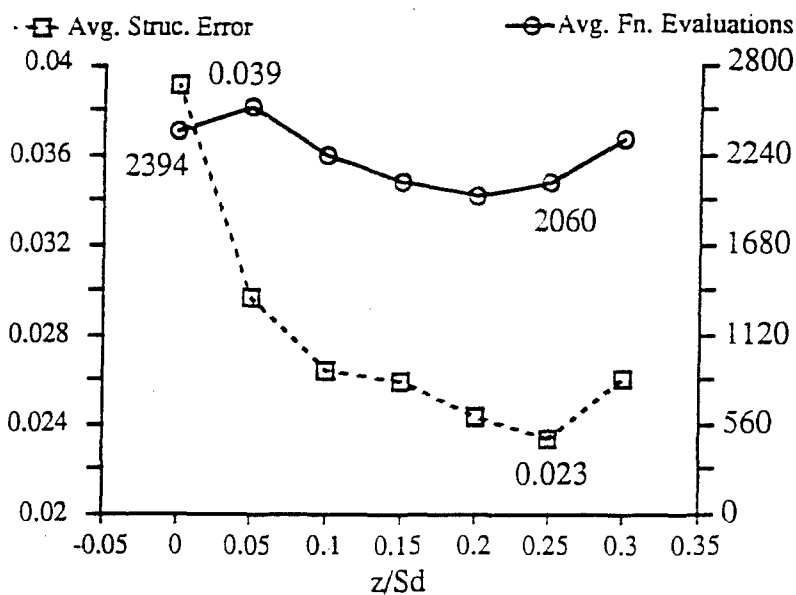

Figure 8. Mean Average Structural Error and Number of Function Evaluations for the Ten Runs at each Tolerance Zone Value, Double-Dwell Example

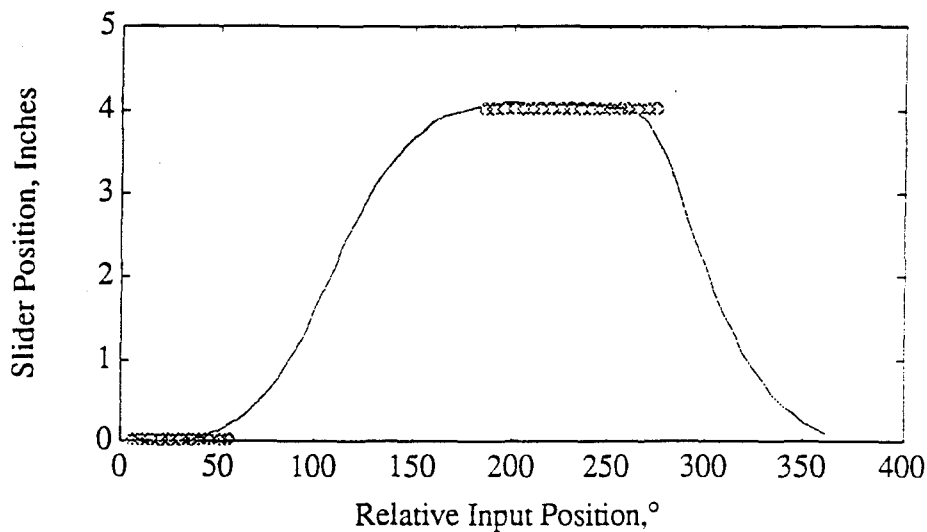

Figure 9. Best Path of Slider Obtained at $z=0.25$. The Circles Correspond to the Position of the Precision Points

CONCLUDING REMARKS

A new formulation has been presented for the synthesis of linkage-type dwell mechanisms with slider outputs. This formulation addresses the difficulties encountered by current numeric optimization-based formulations which often converge to high lying local

minima, or fail to converge to a solution at all, due to the highly non-linear and multi-modal objective functions. The redefinition of the structural error-based objective function about precision lines instead of precision points results in a more efficient search of the design space for optimal solutions. By using precision lines, symmetrical points in the design space are mapped to a single point, thereby effectively shrinking the design space without any loss of information. The single and double dwell examples resulted in a 54% and 41% reduction in structural error, respectively, and required slightly less computational effort than conventional precision point formulations, thereby validating the approach. A parametric study was carried out on the effect of the precision line length on the quality of solution. Significant reductions in the structural error were obtained for both problems at precision line lengths of 20-25% of the desired stroke length, without requiring additional computational effort. Although this study employed SAWI as the optimizer, other stochastic or deterministic optimization algorithms may be used. Finally, the proposed formulation does not eliminate the possibility of converging to high lying local minima, but increases the probability of finding near-optimal solutions.

ACKNOWLEDGEMENTS

This work has been partially supported by the Defence Logistics Agency under CRAMTD contract No. DLA900-88-D-0383. This support is gratefully acknowledged.

REFERENCES

- [1] Wang, A. C. and T. W. Lee (1985). "Design and Analysis of Momentary-Dwell Mechanisms." *Journal of Mechanisms, Transmissions and Automation in Design* **107**: 131-140.
- [2] Kota, S., A. G. Erdman and D. R. Riley (1987). "Development of Knowledge-Base for Designing Linkage-Type Dwell Mechanisms: Part-1 Theory." *Journal of Mechanisms, Transmissions and Automation in Design* **109**: 308 - 315.
- [3] Norton, R. L. (1992). Design of Machinery: An Introduction to the Synthesis and Analysis of Mechanisms and Machines. New York, McGraw Hill Inc.
- [4] Alam, A. B. and D. A. Streit (1994). "Long-Dwell, Finite-Dwell Linkages." ASME Mechanisms Conference, Minneapolis, MN, 479 - 485.
- [5] Kota, S., A. G. Erdman and D. R. Riley (1987). "MINN-DWELL - Computer-Aided Design and Analysis of Linkage-Type Dwell Mechanisms." ASME Computers in Engineering Conference, New York, NY, **2**: 351-358

- [6] Rosen, D., A. G. Erdman and D. R. Riley (1987). "General Design Knowledge-Based Shell, with Application to Dwell Mechanism Design." ASME Computers in Engineering Conference, New York, NY, 1: 29-36
- [7] Kota, S., A. G. Erdman and D. R. Riley (1988). "Dwell Linkages - Representative Models for Quick Practical Solutions." 20th ASME Mechanisms Conference, Kissimmee, FL :91 -101.
- [8] Quadracci, H. R., D. A. Hoeltzel and W. H. Chieng (1990). "Path Generation-Based Pattern Matching for Automated Mechanism Synthesis." ASME Mechanisms Conference, Chicago, IL, 341 -351.
- [9] Kota, S. (1991) "Generic Models for Designing Dwell Mechanisms. A Novel Kinematic Design of Stirling Engines as an Example." Journal of Mechanical Design 113: 446-450.
- [10] Hoeltzel, D. and W.-H. Chieng (1994). "Pattern Matching Synthesis as an Automated Approach to Mechanism Design." Journal of Mechanical Design 112: 190 - 199.
- [11] Ullah, I. and S. Kota (1994). "A More Effective Formulation of the Path Generation Mechanism Synthesis Problem." ASME Mechanism's Conference, Minneapolis, MN, 239 - 244.
- [12] Shimojima, H. and G.L. Ji (1987) "Dimensional Synthesis of Dwell Function Generators. (On 6-Link Stephenson Mechanisms)." JSME International Journal, 30: 324 - 329.
- [13] Hua, D., Y. Miao and S. Wang (1988) " Classification and Kinematic Synthesis of the Six-Bar Long-Dwell Mechanism." Journal of China Textile University - English Edition, 5: 1-6.
- [14] Midha, A., D. A. Turcic and J. R. Bosnik (1984). "Creativity in the Classroom-A Collection of Case Studies in Linkage Synthesis." Journal of Mechanism and Machine Theory 19(1): 25-44.
- [15] Sandor, G. N. and A. G. Erdman (1984). Advanced Mechanism Design: Analysis and Synthesis. Englewood Cliffs, Prentice-Hall Inc.
- [16] Rojanovanich, V. and G. Kinzel (1985) " Approach to the Computer-Aided Design of Dwell Mechanisms." 9th Applied Mechanisms Conference, Kansas City, MO : 28-30
- [17] Midha, A. and Z. L. Zhao (1985). "Synthesis of Planar Linkages via Loop Closure and Non-linear Equations Solution." Journal of Mechanism and Machine Theory 20(6): 491-502.

- [18] Jwo, C-H. and G.K. Mathew (1986) "Five Multiply Separated Positions Dwell Linkage." ASME Mechanisms Conference, Columbus, OH
- [19] Sandgren, E. (1985). "Design of Single and Multiple-Dwell Six Link Mechanisms through Design Optimization." *Journal of Mechanism and Machine Theory* 20(6): 483 - 490.
- [20] Krishnamurty, S. and D. A. Turcic (1992). "Optimal Synthesis of Mechanisms Using Non-Linear Goal Programming Techniques." *Journal of Mechanism and Machine Theory* 27(5): 599 - 612.
- [21] Erdman, A. G. (1991). "The First Forty Years of Modern Kinematics." *Modern Kinematics Conference - A Tribute to Ferdinand Freudenstein*, Minneapolis, MN,
- [22] Aly, S., M. M. Ogot and R. Pelz (1995). "An Improved Simulated Annealing Algorithm for Optimal Design." ASME Design Automation Conference, Boston, Massachusetts.