

ARMY RESEARCH LABORATORY



Finite Element, Finite Difference, and Finite Volume Methods: Examples and Their Comparisons

Josip Z. Šoln

ARL-TR-979

March 1996

APPROVED FOR PUBLIC RELEASE; DISTRIBUTION IS UNLIMITED.

19960321 084

DTIC QUALITY INSPECTED 1

NOTICES

Destroy this report when it is no longer needed. DO NOT return it to the originator.

Additional copies of this report may be obtained from the National Technical Information Service, U.S. Department of Commerce, 5285 Port Royal Road, Springfield, VA 22161.

The findings of this report are not to be construed as an official Department of the Army position, unless so designated by other authorized documents.

The use of trade names or manufacturers' names in this report does not constitute indorsement of any commercial product.

REPORT DOCUMENTATION PAGE

Form Approved
OMB No. 0704-0188

Public reporting burden for this collection of information is estimated to average 1 hour per response, including the time for reviewing instructions, searching existing data sources, gathering and maintaining the data needed, and completing and reviewing the collection of information. Send comments regarding this burden estimate or any other aspect of this collection of information, including suggestions for reducing this burden, to Washington Headquarters Services, Directorate for Information Operations and Reports, 1215 Jefferson Davis Highway, Suite 1204, Arlington, VA 22202-4302, and to the Office of Management and Budget, Paperwork Reduction Project (0704-0188), Washington, DC 20503.

1. AGENCY USE ONLY (Leave blank)		2. REPORT DATE March 1996	3. REPORT TYPE AND DATES COVERED Final, Jan-Jul 95	
4. TITLE AND SUBTITLE Finite Element, Finite Difference, and Finite Volume Methods: Examples and Their Comparisons			5. FUNDING NUMBERS PR: 1L162618AH80	
6. AUTHOR(S) Josip Z. Šoln				
7. PERFORMING ORGANIZATION NAME(S) AND ADDRESS(ES) U.S. Army Research Laboratory ATTN: AMSRL-SL-CM Aberdeen Proving Ground, MD 21010-5423			8. PERFORMING ORGANIZATION REPORT NUMBER ARL-TR-979	
9. SPONSORING / MONITORING AGENCY NAME(S) AND ADDRESS(ES)			10. SPONSORING / MONITORING AGENCY REPORT NUMBER	
11. SUPPLEMENTARY NOTES				
12a. DISTRIBUTION / AVAILABILITY STATEMENT Approved for public release; distribution is unlimited.			12b. DISTRIBUTION CODE	
13. ABSTRACT (Maximum 200 words) Elementary descriptions of finite element and finite difference methods are given while the finite volume method is briefly overviewed. Examples illustrating finite element and finite difference methods are worked out. Finally, comparisons of these methods between themselves and with some examples from literature are given.				
14. SUBJECT TERMS finite element, finite difference, finite volume			15. NUMBER OF PAGES 57	
			16. PRICE CODE	
17. SECURITY CLASSIFICATION OF REPORT UNCLASSIFIED	18. SECURITY CLASSIFICATION OF THIS PAGE UNCLASSIFIED	19. SECURITY CLASSIFICATION OF ABSTRACT UNCLASSIFIED	20. LIMITATION OF ABSTRACT UL	

INTENTIONALLY LEFT BLANK.

ACKNOWLEDGMENT

The author wishes to thank his friend and colleague Brian G. Ruth for participating in some very useful discussions. Brian's invaluable comments and suggestions helped bring this report to the present form.

INTENTIONALLY LEFT BLANK.

TABLE OF CONTENTS

	<u>Page</u>
ACKNOWLEDGMENT	iii
LIST OF FIGURES	vii
1. INTRODUCTION	1
2. EXPOSITION OF THE METHODS	1
2.1 Finite Element Method	1
2.2 Finite Difference Method	21
2.3 Finite Volume Method	34
3. COMPARISONS OF METHODS	37
4. POTENTIAL APPLICATIONS, DISCUSSIONS, AND CONCLUSIONS	39
5. REFERENCES	41
BIBLIOGRAPHY	43
DISTRIBUTION LIST	47

INTENTIONALLY LEFT BLANK.

LIST OF FIGURES

<u>Figure</u>	<u>Page</u>
1. The 1-D two-node element	5
2. The interpolation functions N_1 and N_2 associated with the two nodal points $x_1 = 0$, and $x_2 = \pi/2$, respectively, for the 1-D two-node element	7
3. Approximation of $f(x) = \cos x$ by two interpolation functions associated with the 1-D two-node element. Comparison with Figure 4 shows that the agreement is not perfect	8
4. Plot of $\cos x$ between $x = 0$ and $x = \pi/2$	8
5. Interpolation functions N_1 , N_2 , and N_3 associated with the three nodal points $x_1 = 0$, $x_2 = \pi/4$, and $x_3 = \pi/2$, respectively, for the 1-D three-node element	10
6. Approximation of $f(x) = \cos x$ by the three interpolation functions associated with the 1-D three-node element. The agreement with Figure 4 is now excellent	11
7. 2-D four-node quadrilateral element	12
8. Interpolation function N_1 associated with the nodal point $\bar{r}_1 = (1,1)$ of the four-node quadrilateral element. The interpolation functions N_2 , N_3 , and N_4 (associated with the nodal points $\bar{r}_2 = (-1,1)$, $\bar{r}_3 = (-1,-1)$, and $\bar{r}_4 = (1,-1)$) are obtained from N_1 by rotating the x-y plane clockwise about the z-axis by $\pi/2$, $2\pi/2$, and $3\pi/2$ angles, respectively	14
9. Plot of $\exp [-(x + y)]$ in the region $-1 \leq x, y \leq 1$	14
10. Approximation of $\exp [-(x + y)]$ by the four interpolation functions associated with the quadrilateral element from Figure 8	15
11. Square region with a constant surface charge σ generating the solution f from the Poisson equation in 2-D space. At the boundary, the solution f is required to vanish	16
12. Plot of the lowest order polynomial function with the same symmetries as the function f from Figure 11	17
13. Plot of the second lowest order polynomial function with the same symmetries as the function f from Figure 11	18
14. Plot of f , the approximate solution of the 2-D Poisson equation with the unit surface charge density, $\sigma = 1$	20

<u>Figure</u>		<u>Page</u>
15.	Definition of the equal interval Δx from which the forward, the backward, and the central differences of $y(x)$ are defined	21
16.	Graphic representation of the evolution of $y(x)$, the solution of the first-order differential equation, in terms of $h = \Delta x$	32

1. INTRODUCTION

Modern scientific and engineering projects have become too complex and costly to be carried out with just the old-fashioned "trial and error" approach. Therefore, it is imperative that such projects first be modeled and verified mathematically. Unfortunately, due to the complexity of these projects, the mathematical modeling seldom can be done entirely in analytical forms. As a consequence, one must resort to "approximate" methods; that is, methods which either entirely or partially use numerical methods when modeling the project. The most popular approximate methods in use today are the finite element and the finite difference methods. A new method is the finite-volume method, however, it is not yet very popular in modeling; this is very likely due to the fact that, as the models go, it is rather laborious to use. Consequently, in this brief description, attention will be paid more to finite element and finite difference methods than to the finite volume method. The emphasis here is to give an overview of these methods so that interested readers can pursue details in the literature on their own.

In section 2, some basic notions and applications of finite element and finite difference methods are given. Here also the finite volume method is briefly described. Merits of one vs. the other method are discussed in section 3. Section 4 is mainly devoted to a listing of possible potential applications of these methods, and contains the discussion and conclusion. In the appendix, listings of the available literature on these methods are given.

2. EXPOSITION OF THE METHODS

Here simple applications of finite element and finite difference methods are described, while a brief overview of the finite volume method is given.

2.1 Finite Element Method. A mathematical model of a physical system normally involves a number of variables and functions $f_{ex}(\vec{x})$ representing fields, velocities, etc. Here \vec{x} represents the coordinates of the domain. The problem is that the exact function $f_{ex}(\vec{x})$ is not known for all the points \vec{x} . Hence, one introduces an approximation of $f_{ex}(\vec{x})$, denoted simply as $f(\vec{x})$. The error function $e(\vec{x})$,

$$e(\vec{x}) = f(\vec{x}) - f_{ex}(\vec{x}), \quad (2.1.1)$$

measures the quality of the approximation. To construct an approximate $f(\bar{x})$ it suffices to: (1) write an expression containing n parameters a_i ,

$$f(\bar{x}) = f(\bar{x}; a_1, \dots, a_n), \quad (2.1.2)$$

and (2) relate (determine) these parameters to n values of $f_{ex}(\bar{x})$ in the domain, which may be known or may still have to be determined by some other methods (Dhatt and Touzot 1984). Formally, this may be achieved by forcing the error function $e(\bar{x})$ to be zero at " n " points in the domain.

The question that immediately arises is how to construct the approximate function $f(\bar{x}; a_1, \dots, a_n)$, dependent on parameters a_i , $i = 1, \dots, n$. Rather frequently, an approximation function is chosen to be a linear function of parameters a_i , $i = 1, \dots, n$:

$$f(\bar{x}) = \sum_{i=1}^n a_i P_i(\bar{x}), \quad (2.1.3a)$$

$$f(\bar{x}) = \langle P_1(\bar{x}) \ P_2(\bar{x}) \ \dots \ P_n(\bar{x}) \rangle \begin{pmatrix} a_1 \\ a_2 \\ \cdot \\ \cdot \\ a_n \end{pmatrix}, \quad (2.1.3b)$$

or in shorthand,

$$f(\bar{x}) = \langle P(\bar{x}) \rangle (a_n), \quad (2.1.3c)$$

where $P_i(\bar{x})$, $i = 1, \dots, n$, are linearly independent complete sets of functions. In the finite element method, P 's have been chosen as polynomials, although other sets of functions may be used. Parameters a_i , $i = 1, \dots, n$, are the generalized parameters of approximation.

Unfortunately, parameters a_i generally do not have a direct physical meaning. Thus, as far as the finite element method goes, they are conveniently replaced with nodal values of the function $f_{ex}(\bar{x})$ at, say, m points with coordinates $\bar{x}_1, \bar{x}_2, \dots, \bar{x}_m$. The nodal approximation is further required to satisfy the following relations:

$$f(\bar{x}_i) = f_{ex}(\bar{x}_i) \equiv f_i, \quad i = 1, 2, \dots, m. \quad (2.1.4)$$

Hence, the approximate function $f(\bar{x})$ can now be written as

$$f(\bar{x}) = \sum_{i=1}^n N_i(\bar{x}) f_i \quad (2.1.5a)$$

$$= \langle N_1(\bar{x}) \ N_2(\bar{x}) \ \dots \ N_m(\bar{x}) \rangle \begin{pmatrix} f_1 \\ f_2 \\ \cdot \\ \cdot \\ f_m \end{pmatrix}, \quad (2.1.5b)$$

or, in shorthand notation,

$$f(\bar{x}) = \langle N(\bar{x}) \rangle (f_m). \quad (2.1.5c)$$

Here $f_i, i = 1, 2, \dots, m$, are nodal parameters, and functions $N(\bar{x})$ are called (nodal) interpolation functions. Clearly, consistent with relations (2.1.4) and (2.1.5), one has

$$N_j(\bar{x}_i) = \delta_{ij}, \quad e(\bar{x}_i) = 0. \quad (2.1.6,7)$$

Understandably, for some approximate function the generalized approximation (2.1.3) and the nodal approximation (2.1.5) must be equal. Hence $\langle P(\bar{x}) \rangle$ and $\langle N(\bar{x}) \rangle$ must be related to each other. First of all from relation (2.1.3) one can write,

$$F_i = \langle P(\bar{x}) \rangle (a), i = 1, 2, \dots, m. \quad (2.1.8a)$$

In matrix form the same thing is written as

$$\begin{pmatrix} f_1 \\ f_2 \\ \vdots \\ f_m \end{pmatrix} = \begin{pmatrix} \langle P_1(\bar{x}_1) P_2(\bar{x}_1) \dots P_n(\bar{x}_1) \rangle \\ \langle P_1(\bar{x}_2) P_2(\bar{x}_2) \dots P_n(\bar{x}_2) \rangle \\ \dots \\ \dots \\ \dots \\ \langle P_1(\bar{x}_m) P_2(\bar{x}_m) \dots P_n(\bar{x}_m) \rangle \end{pmatrix} \begin{pmatrix} a_1 \\ a_2 \\ \vdots \\ a_n \end{pmatrix}, \quad (2.1.8b)$$

where one should notice that the matrix itself is not generally a "square" matrix. In a shorthand notation, this relation is rewritten as

$$(f_m) = [P] (a_n). \quad (2.1.8c)$$

However, unless something explicit forbids it, one may choose the number of P-functions and the number of nodal points to be the same.

Relations (2.1.8) relate nodal parameters $f_i, i = 1, 2, \dots, m$, and the generalized parameters $a_j, j = 1, 2, \dots, n$. Substitution of (2.1.8c) into (2.1.5b), after comparison with (2.1.3), yields

$$\langle P(\bar{x}) \rangle = \langle N(\bar{x}) \rangle [P], \quad (2.1.9)$$

and

$$\langle N(\bar{x}) \rangle = \langle P(\bar{x}) \rangle [Q], [Q] = [P]^{-1}. \quad (2.1.10a,b)$$

Since the P-functions can be chosen as simple polynomial functions, it is relation (2.1.10a) that is of real value; it defines the interpolation (nodal) functions in terms of P's. The problem, however, is evaluating the matrix [Q].

The following is an example of the construction of interpolation functions for the simplest of the elements, the linear (two nodes) element; it is linear because we take the number of polynomial basis functions to be equal to the number of nodes: $n = m = 2$. The one-dimensional (1-D) two-node elements are exhibited in Figure 1.



Figure 1. The 1-D two-node element.

The polynomial basis functions are given by a two-component vector:

$$\langle P(x) \rangle = \langle P_1(x) \ P_2(x) \rangle = \langle 1 \ x \rangle. \quad (2.1.11)$$

According to (2.1.8b and c) the matrix [P] is

$$[P] = \begin{bmatrix} 1 & x_1 \\ 1 & x_2 \end{bmatrix} \quad (2.1.12)$$

This matrix can be easily inverted with the result

$$[Q] = \frac{1}{D} \begin{bmatrix} x_2 & -x_1 \\ -1 & 1 \end{bmatrix}, \quad D = \det[P] = x_2 - x_1. \quad (2.1.13)$$

Consequently, from relations (2.1.10a), the interpolation functions are

$$\langle N(x) \rangle = \langle N_1(x) \ N_2(x) \rangle = \frac{1}{(x_2 - x_1)} \langle 1 \ x \rangle \begin{bmatrix} x_2 & -x_1 \\ -1 & 1 \end{bmatrix}, \quad (2.1.14a)$$

giving specifically,

$$N_1(x) = \frac{x_2 - x}{x_2 - x_1}, \quad N_2(x) = \frac{x - x_1}{x_2 - x_1}. \quad (2.2.14b)$$

One verifies explicitly relation (2.1.6) in this case.

The function $f_{ex}(x)$ can now be approximated with $f(x)$ in the interval $x_1 \leq x \leq x_2$:

$$f(x) = \frac{1}{(x_2 - x_1)} \left[(x_2 - x) f_1 + (x - x_1) f_2 \right]. \quad (2.1.15)$$

To be specific, choose for the nodal points:

$$x_1 = 0, \quad x_2 = \frac{\pi}{2}, \quad (2.1.16a)$$

with which the following interpolation functions are associated:

$$N_1(x) = \frac{2}{\pi} \left(\frac{\pi}{2} - x \right), \quad N_2(x) = \frac{2}{\pi} x. \quad (2.1.16b)$$

Their plots are shown in Figure 2.

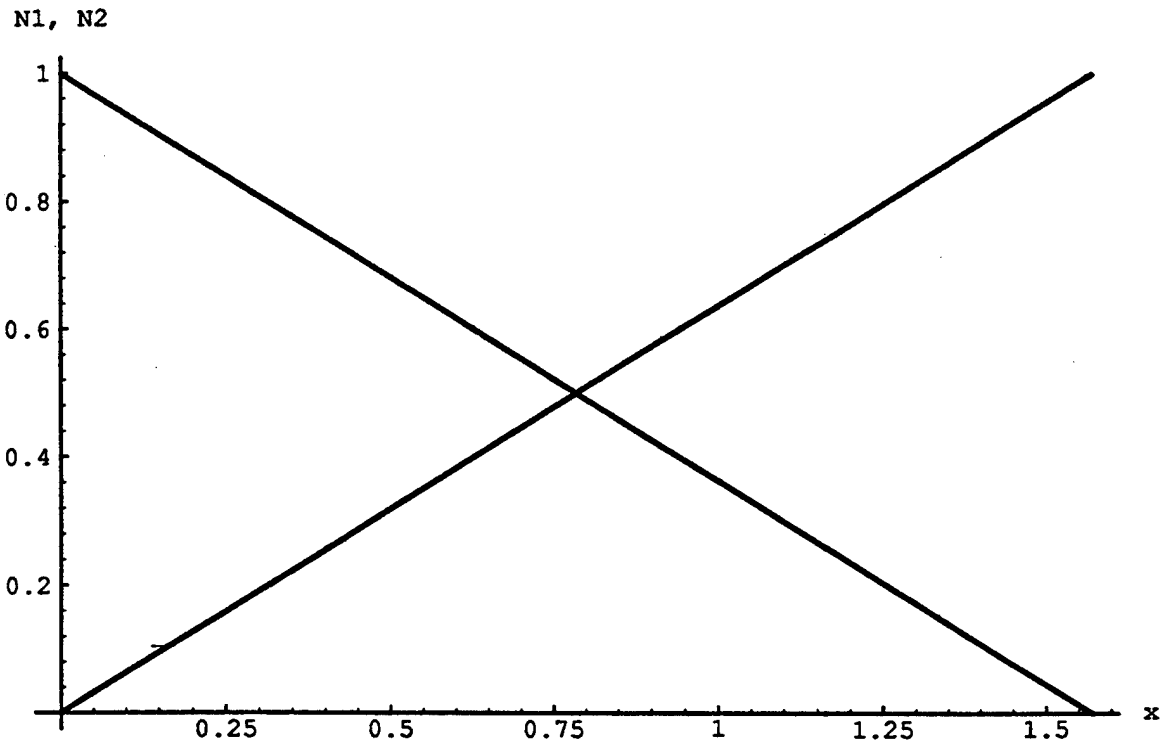

Figure 2. The interpolation functions N_1 and N_2 associated with the two nodal points $x_1 = 0$ and $x_2 = \pi/2$, respectively, for the 1-D two-node element.

Next, let us see how $f(x)$ approximates $f_{\text{ex}}(x) = \cos x$ with these two nodes, relation (2.1.16b). We have

$$f_{\text{ex}}(x_1 = 0) = \cos x_1 = 1 \equiv f_1, \quad f_{\text{ex}}\left(x_2 = \frac{\pi}{2}\right) = \cos x_2 = 0 \equiv f_2, \quad (2.1.16c)$$

giving,

$$f(x) = \frac{2}{\pi} \left(\frac{\pi}{2} - x \right), \quad x_1 \leq x \leq x_2. \quad (2.1.16d)$$

From the plots (Figures 3 and 4) we see that the agreement is not perfect.

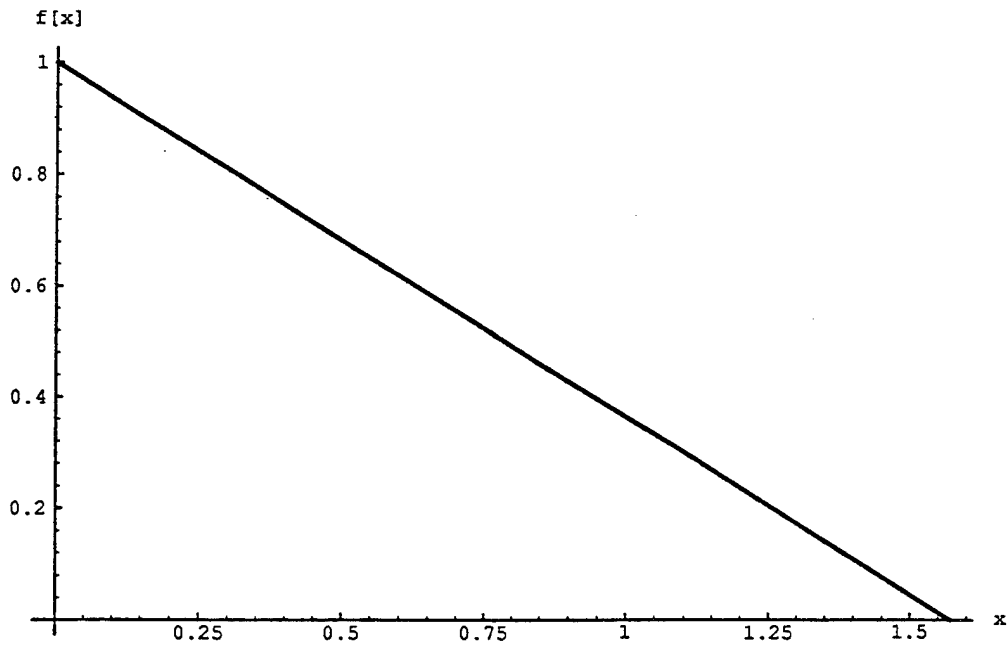

Figure 3. Approximation of $f(x) = \cos x$ by two interpolational functions associated with the 1-D two-node element. Comparison with Figure 4 shows that the agreement is not perfect.

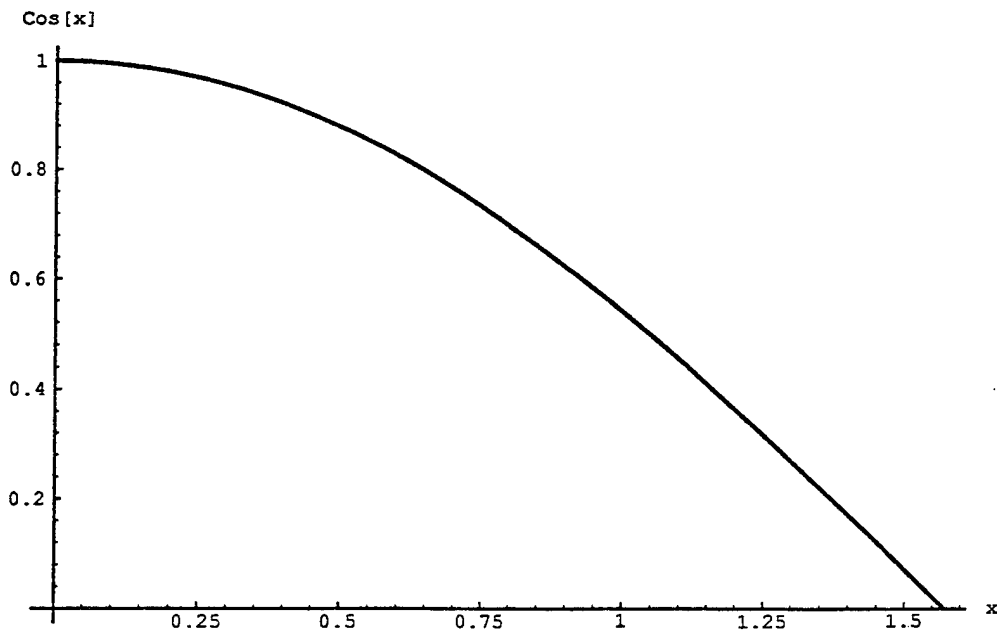

Figure 4. Plot of $\cos x$ between $x = 0$ and $x = \pi/2$.

The reason for this, of course, is that the number of nodal points is too small.

To improve on the approximation, let us take three nodes, x_1 , x_2 , and x_3 . The polynomial basis is now given by the three-component vector:

$$\langle P(x) \rangle = \langle 1, x, x^2 \rangle. \quad (2.1.17)$$

Following the previous example (see also (2.1.8a)), one also writes down the matrix

$$[P] = \begin{bmatrix} 1 & x_1 & x_1^2 \\ 1 & x_2 & x_2^2 \\ 1 & x_3 & x_3^2 \end{bmatrix}. \quad (2.1.18)$$

Unfortunately, the expression for $[Q]$ is too long to be given in a general form. However, for the nodal points

$$x_1 = 0, \quad x_2 = \frac{\pi}{4}, \quad x_3 = \frac{\pi}{2}, \quad (2.1.19a)$$

the expression is

$$[Q] = \begin{bmatrix} 1 & 0 & 0 \\ -\frac{6}{\pi} & \frac{8}{\pi} & -\frac{2}{\pi} \\ \frac{8}{\pi^2} & -\frac{16}{\pi^2} & \frac{8}{\pi^2} \end{bmatrix}. \quad (2.1.19b)$$

From

$$\langle N(x) \rangle = \langle N_1(x), N_2(x), N_3(x) \rangle = \langle P(x) \rangle [Q], \quad (2.1.19c)$$

we obtain

$$N_1(x) = 1 - \frac{6x}{\pi} + \frac{8x^2}{\pi^2}, \quad N_2(x) = \frac{8x}{\pi} - \frac{16x^2}{\pi^2}, \quad N_3(x) = -\frac{2x}{\pi} + \frac{8x^2}{\pi^2}. \quad (2.1.19d)$$

The plots of these functions are shown in Figure 5.

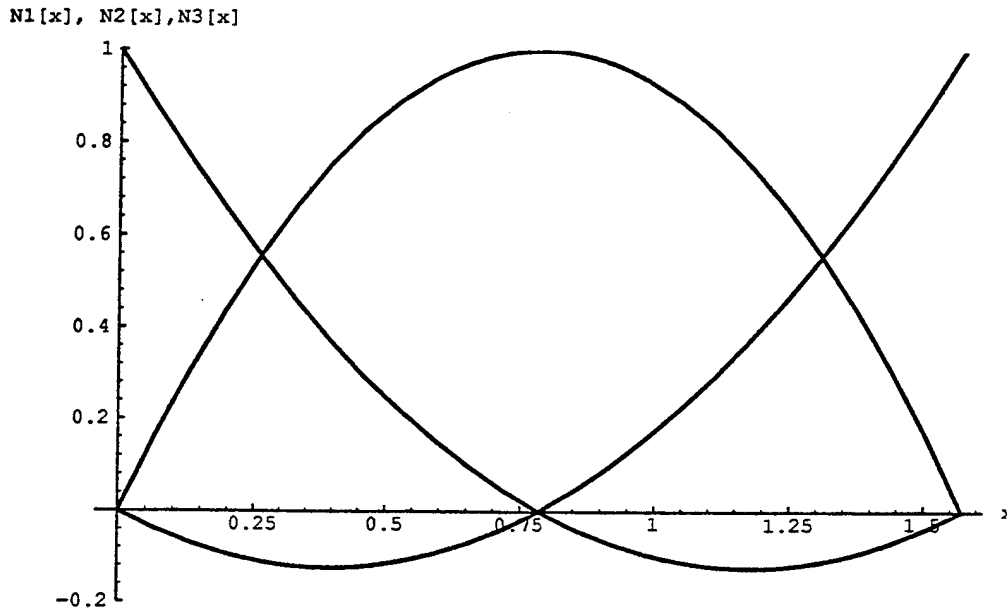

Figure 5. Interpolation functions N_1 , N_2 , and N_3 associated with the three nodal points $x_1 = 0$, $x_2 = \pi/4$, and $x_3 = \pi/2$, respectively, for the 1-D three-node element.

Now $f_{ex}(x) = \cos x$ yields

$$f_{ex}(x_1 = 0) = 1 \equiv f_1, \quad f_{ex}\left(x_2 = \frac{\pi}{4}\right) = \frac{1}{\sqrt{2}} \equiv f_2, \quad f_{ex}\left(x_3 = \frac{\pi}{2}\right) = 0 \equiv f_3, \quad (2.1.19e)$$

yielding

$$f(x) = 1 - \frac{6x}{\pi} + \frac{8x^2}{\pi^2} + \frac{1}{\sqrt{2}} \left[\frac{8x}{\pi} - \frac{16x^2}{\pi^2} \right]. \quad (2.1.19f)$$

The plot of $f(x)$ is shown in Figure 6. The agreement with the plot for $\cos x$ from Figure 4 is now much better.

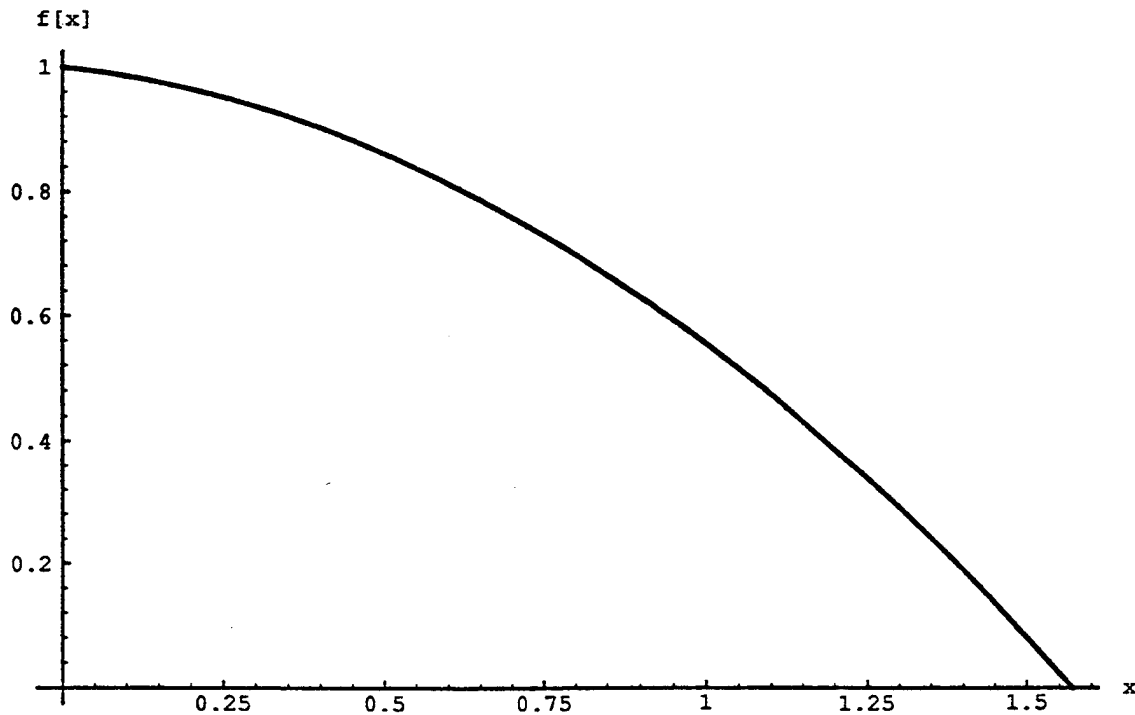

Figure 6. Approximation of $f(x) = \cos x$ by the three interpolation functions associated with the 1-D three-node element. The agreement with Figure 4 is now excellent.

Now we take an example in the two-dimensional (2-D) space. In order to simplify the discussion, we specify the nodal points from the beginning:

$$\bar{r}_1 = (1,1), \bar{r}_2 = (-1,1), \bar{r}_3 = (-1,-1), \bar{r}_4 = (1,-1), \quad (2.1.20)$$

where in general $\bar{r} = (x,y)$. The element associated with these four nodal points is referred to as a 2-D four-nodal quadrilateral element, $m = 4$. Its plot is exhibited in Figure 7.

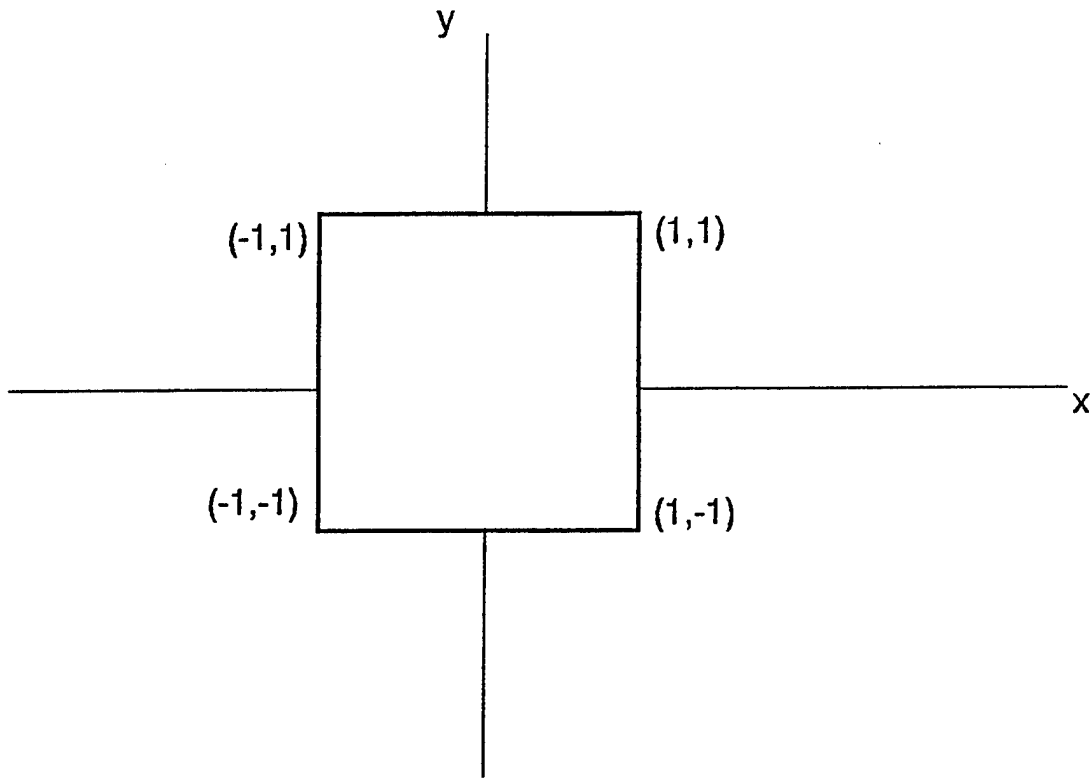

Figure 7. 2-D four-node quadrilateral element.

(Because of the way the nodal points are chosen, this and other elements like this one are also referred to as "reference elements"). As far as the polynomial basis functions are concerned, they are defined through the four-component vector ($n = 4$):

$$\langle P(\vec{r}) \rangle = \langle 1, x, y, xy \rangle. \quad (2.1.21)$$

Following the general prescription for constructing the interpolation functions, with the help of $\langle P(\vec{r}) \rangle = \langle 1, x, y, xy \rangle$ evaluated at positions of nodal points, we first write down the four-by-four matrix

$$[\mathbf{P}] = \begin{bmatrix} 1 & 1 & 1 & 1 \\ 1 & -1 & 1 & -1 \\ 1 & -1 & -1 & 1 \\ 1 & -1 & 1 & -1 \end{bmatrix}, \quad (2.1.22a)$$

which when inverted yields

$$[Q] = \frac{1}{4} \begin{bmatrix} 1 & 1 & 1 & 1 \\ 1 & -1 & -1 & 1 \\ 1 & 1 & -1 & -1 \\ 1 & -1 & 1 & -1 \end{bmatrix}. \quad (2.1.22b)$$

Now applying now relations (2.1.22b) and (2.1.21) to relation (2.1.10a) one obtains the following expression for the interpolation functions:

$$\begin{aligned} N_1(x,y) &= \frac{1}{4} (1 + x + y + xy), & N_2(x,y) &= \frac{1}{4} (1 - x + y - xy), \\ N_3(x,y) &= \frac{1}{4} (1 - x - y + xy), & N_4(x,y) &= \frac{1}{4} (1 + x - y - xy). \end{aligned} \quad (2.1.22c)$$

In Figure 8, the first of these four functions is displayed. The other three are obtained by rotating the x-y plane about z-axis clockwise by $\frac{\pi}{2}$, $2\frac{\pi}{2}$, and $3\frac{\pi}{2}$ angles, respectively.

To demonstrate how things work in the 2-D space, we choose for the exact function the expression:

$$f_{\text{ex}}(x,y) = \exp[-(x + y)]. \quad (2.1.23a)$$

From relations (2.1.20) the nodal parameters are:

$$f_1 = e^{-2} = 0.13534, f_2 = 1, f_3 = e^2 = 7.38906, f_4 = 1; \quad (2.1.23b)$$

yielding on this element for $\exp[-(x + y)]$ the appropriate expression:

$$f(x,y) = 0.135 N_1(x,y) + N_2(x,y) + 7.389 N_3(x,y) + N_4(x,y). \quad (2.1.23c)$$

The plots of f_{ex} and f are exhibited on Figures 9 and 10, respectively.

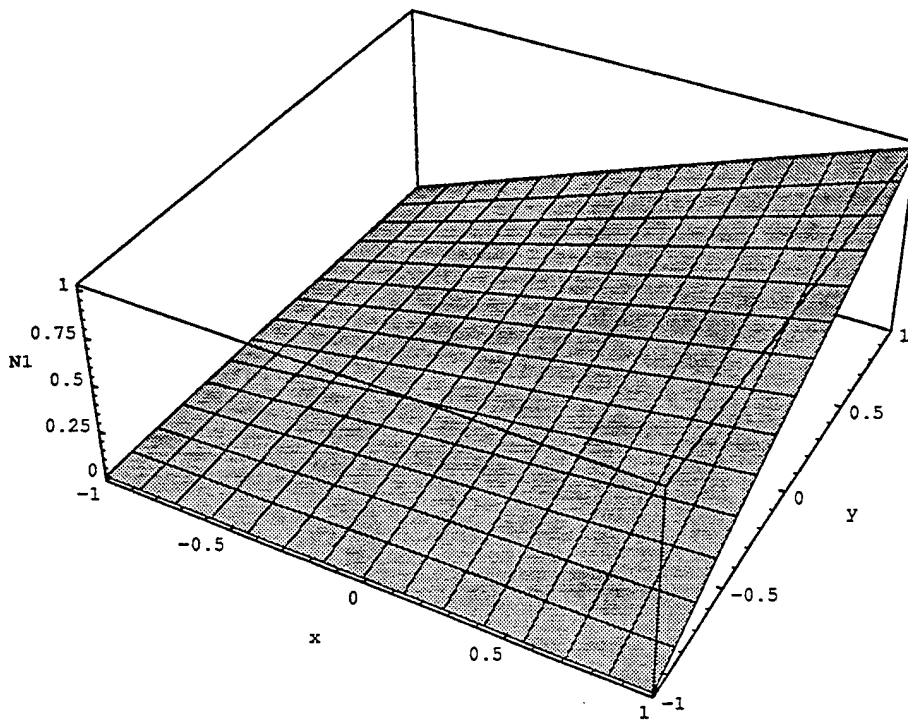

Figure 8. Interpolation function N_1 associated with the nodal point $\bar{r}_1 = (1,1)$ of the four-node quadrilateral element. The interpolation functions N_2 , N_3 , and N_4 (associated with the nodal points $\bar{r}_2 = (-1,1)$, $\bar{r}_3 = (-1,-1)$, and $\bar{r}_4 = (1,-1)$) are obtained from N_1 by rotating the x-y plane clockwise about the z-axis by $\pi/2$, $2\pi/2$, and $3\pi/2$ angles, respectively.

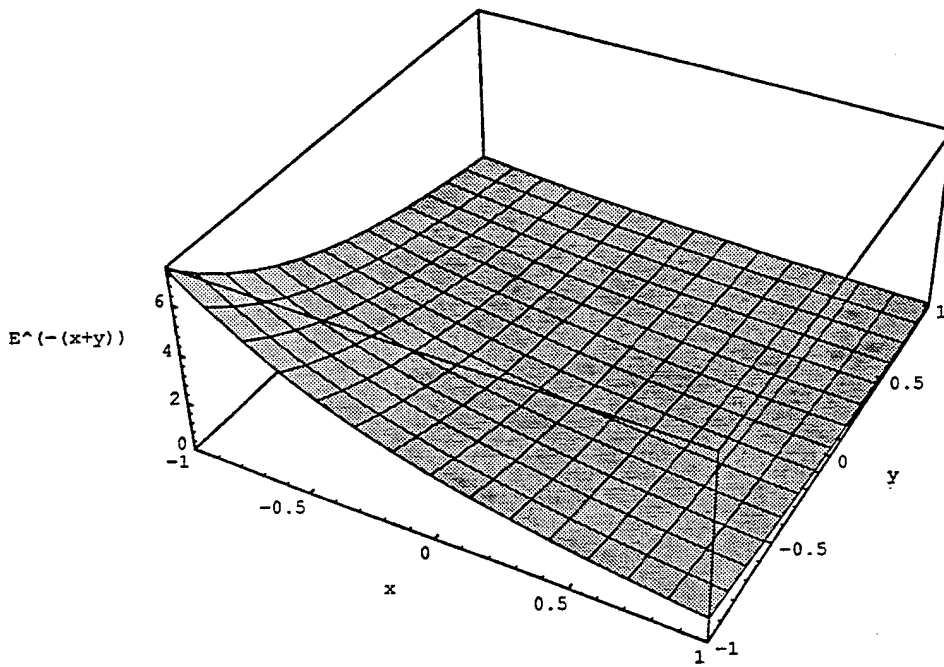

Figure 9. Plot of $\exp[-(x+y)]$ in the region $-1 \leq x, y \leq 1$.

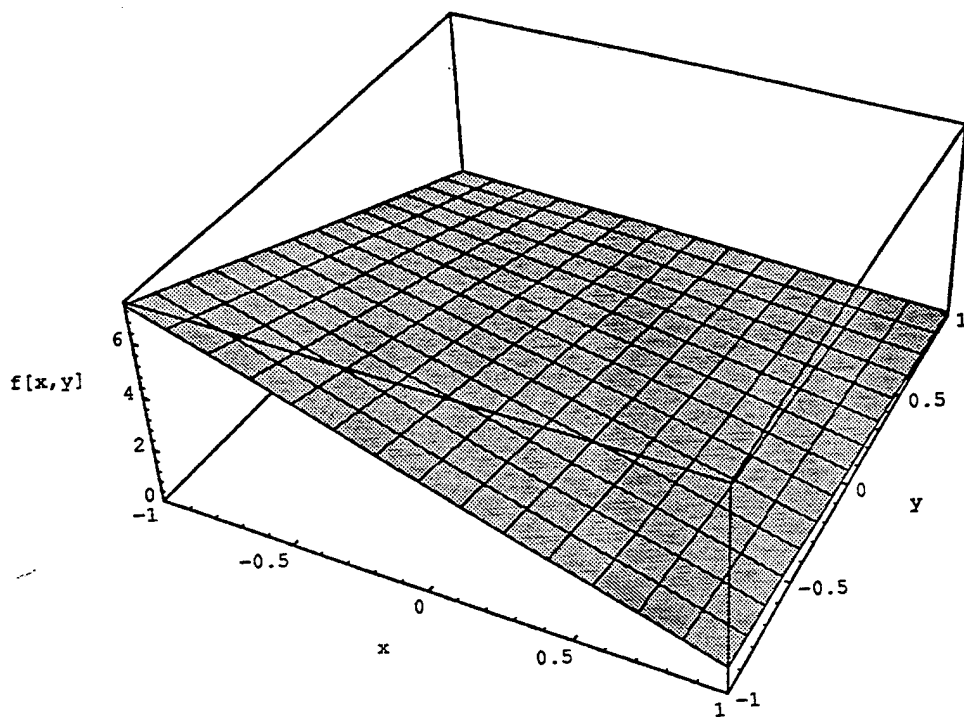

Figure 10. Approximation of $\exp [-(x + y)]$ by the four interpolation functions associated with the quadrilateral element from Figure 8.

The agreement is quite good, taking into account that we used only four nodal points, which is not a large number for the 2-D space. If the number of nodal points is increased at least by one, the agreement would be perfect.

Of course, there are many more elements that one can consider, not just in 1- and 2-D spaces, but, in fact, in an arbitrary dimensional space. However, such a study is beyond the scope of this report.

Finally, we illustrate briefly how to solve a partial differential equation by finite element method. To be specific, we treat Poisson's equation in the 2-D space defined over a square region (which is actually the quadrilateral element from the previous example) with a constant surface "charge density" σ (consult Figure 11 for details).

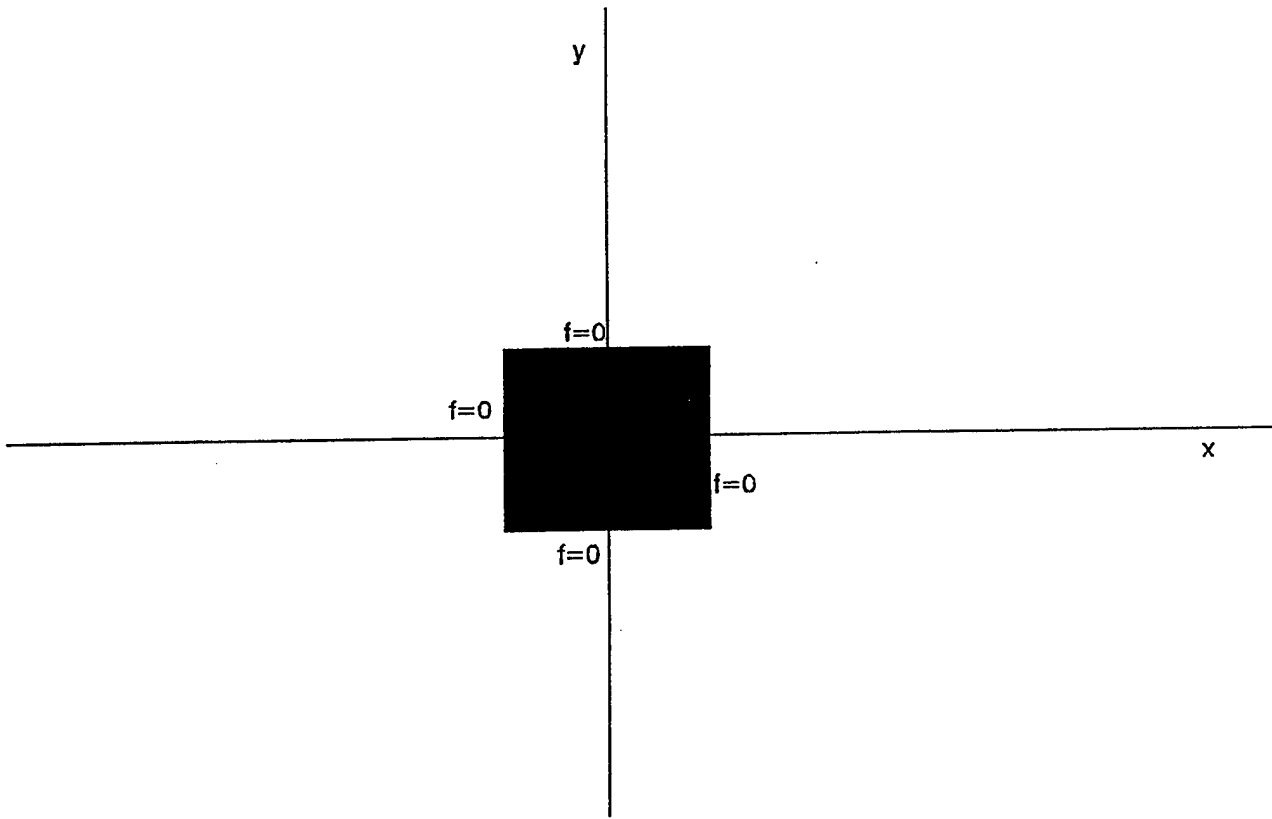

Figure 11. Square region with a constant surface charge σ generating the solution f from the Poisson equation in 2-D space. At the boundary, the solution f is required to vanish.

We write the differential equation as follows:

$$\Delta(f) + \sigma = \frac{\partial^2 f(x,y)}{\partial x^2} + \frac{\partial^2 f(x,y)}{\partial y^2} + \sigma = 0, \quad (2.1.24a)$$

where

$$\sigma \neq 0: -1 \leq x \leq 1, -1 \leq y \leq 1; \sigma = 0 \text{ elsewhere.} \quad (2.1.24b)$$

One easily sees from equation (2.1.24a) that the solution possesses the following symmetries:

$$f(x,y) = f(y,x); f(x,y) = f(-x,y) = f(-x,-y) = f(x,-y). \quad (2.1.24c)$$

Furthermore, we also require that f satisfy these boundary value conditions:

$$f(\pm 1, y) = f(x, \pm 1) = 0. \quad (2.1.24d)$$

Because of the symmetry and the boundary value conditions, representation of f in terms of a just-derived four-node quadrilateral element would not be enough; one would have to construct at least a five-node element. However, rather than do that, let us actually exploit the symmetry of the problem, and instead of interpolation functions, use the polynomial functions as discussed at the beginning of this section. To simplify the discussion, we use just two of them; the simplest ones that satisfy conditions of symmetry and the boundary values are:

$$P_1(x, y) = (x^2 - 1)(y^2 - 1); \quad P_2(x, y) = (x^2 + y^2) P_1(x, y). \quad (2.1.25a)$$

Their plots are shown on Figures 12 and 13.

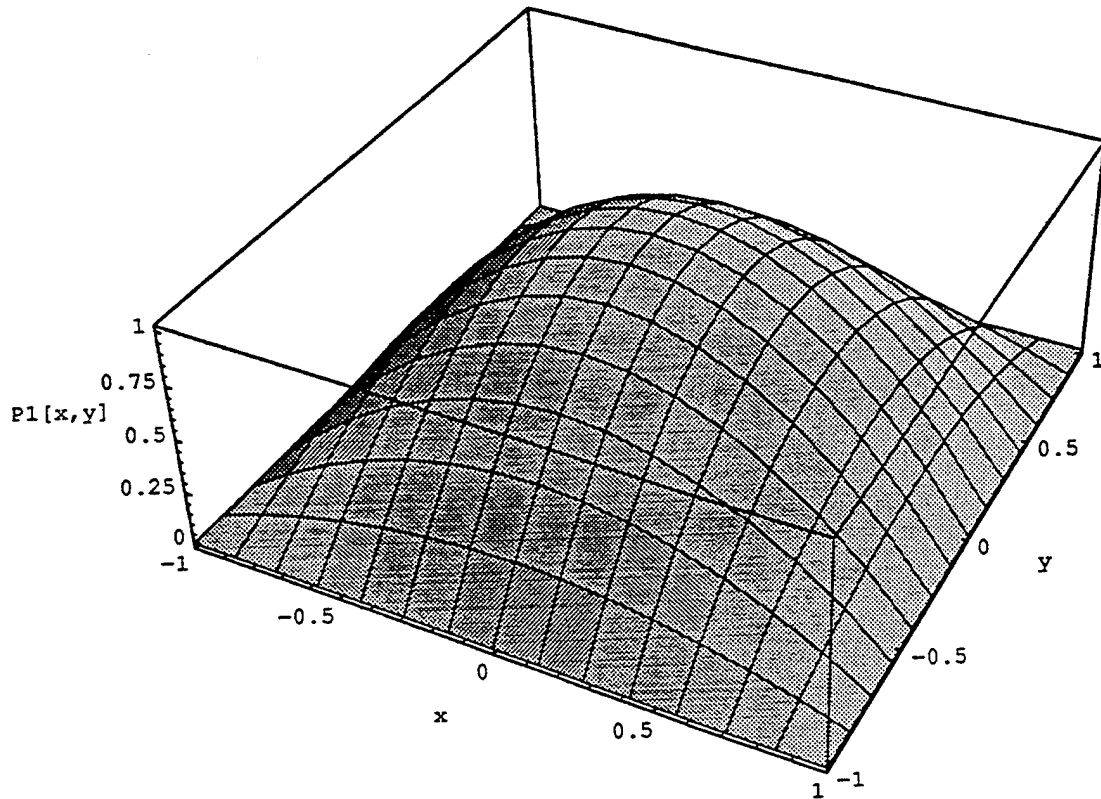

Figure 12. Plot of the lowest order polynomial function with the same symmetries as the function f from Figure 11.

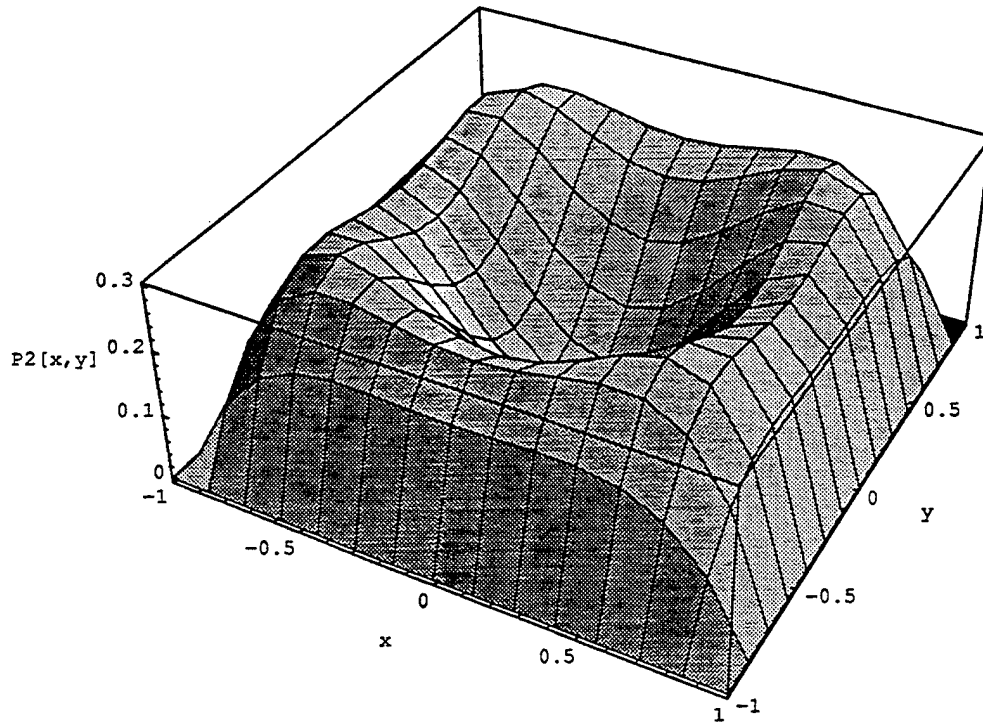

Figure 13. Plot of the second lowest order polynomial function with the same symmetries as the function f from Figure 11.

These functions allow us to express the f in terms of two generalized parameters of approximation a_1 and a_2 :

$$f(x,y) = \langle P_1(x,y) \ P_2(x,y) \rangle \begin{bmatrix} a_1 \\ a_2 \end{bmatrix} = P_1(x,y) a_1 + P_2(x,y) a_2. \quad (2.1.25b)$$

One notices that now the differential equation (2.1.24a) decomposes as

$$\begin{aligned} \mathcal{L}(f) &= a_1 \mathcal{L}(P_1) + a_2 \mathcal{L}(P_2), \quad \mathcal{L}(P_1) = 2(x^2 + y^2 - 2), \\ \mathcal{L}(P_2) &= 2(6x^2 - 1)(y^2 - 1) + 2(6y^2 - 1)(x^2 - 1) \\ &\quad + 2(x^4 - x^2) + 2(y^4 - x^2). \end{aligned} \quad (2.1.25c)$$

The problem now, of course, is to find a_1 and a_2 .

In order to determine a_1 and a_2 , we choose two collocation points (points inside the square where $\sigma \neq 0$):

$$\bar{r}_1 = (0,0), \bar{r} = \left(\frac{1}{2}, \frac{1}{2}\right), \quad (2.1.26a)$$

and define, in general, the weight functions

$$W_i = (\mathcal{L}(f) + \sigma)_{\bar{r}_i} = (a_1 \mathcal{L}(P_1) + a_2 \mathcal{L}(P_2) + \sigma)_{\bar{r}_i}; \quad W_i = 0. \quad (2.1.26b,c)$$

The statement (2.1.26c) means that the differential equation is satisfied exactly at the collocation points. One obtains explicitly

$$W_1 = -4 a_1 + 4 a_2 + \sigma = 0, \quad W_2 = -3 a_1 - \frac{9}{4} a_2 + \sigma = 0, \quad (2.1.27a)$$

with solutions

$$a_1 = 0.2976 \sigma, \quad a_2 = 0.0476 \sigma. \quad (2.1.27b)$$

This gives

$$f(x,y) = 0.2976 \sigma (x^2 - 1) (y^2 - 1) + 0.047 \sigma (x^2 + y^2) (x^2 - 1) (y^2 - 1). \quad (2.1.27c)$$

The function f is shown in Figure 14 for $\sigma = 1$.

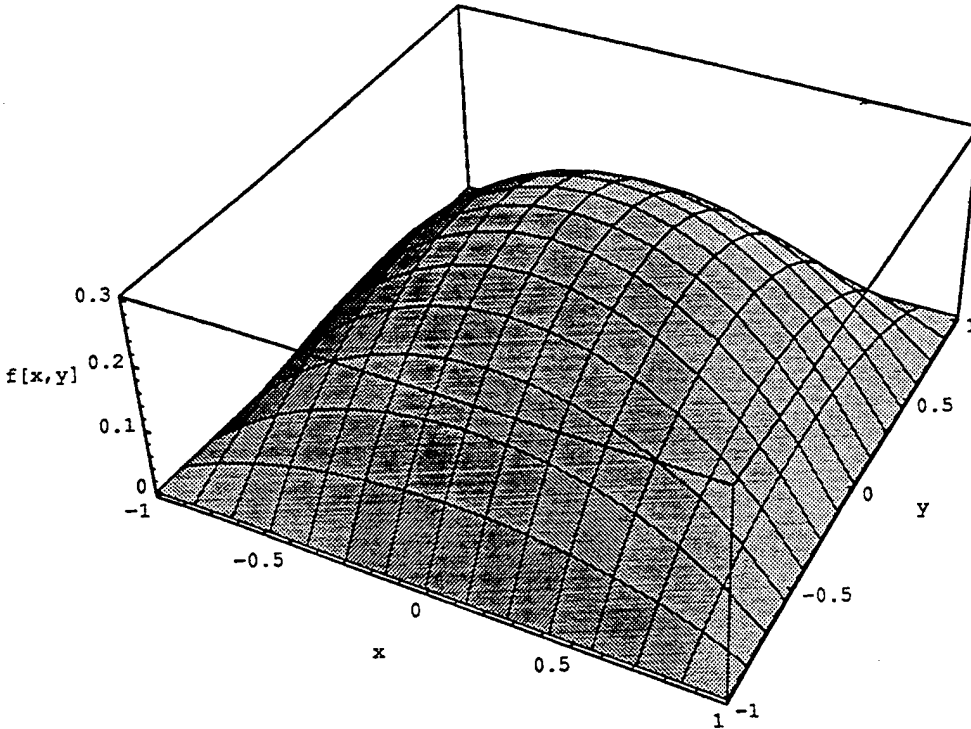

Figure 14. Plot of f , the approximate solution of the 2-D Poisson equation with the unit surface charge density, $\sigma = 1$.

Our result compares very well with the one obtained from the Fourier series expansion. Specifically, from there one obtains for f at $\vec{r} = 0$ the value:

$$\text{Fourier Series:} \quad f(\vec{r} = 0) = 0.2976\sigma. \quad (2.1.27d)$$

On the other hand, directly from solution (2.1.27c), we have

$$f(\vec{r} = 0) = a_1 = 0.2976\sigma, \quad (2.1.27e)$$

which is practically the same as the Fourier series result.

Although rather simple, the few examples chosen here illustrate clearly the power of the finite element method. The interested reader can find more involved examples in a rather extensive survey of the literature, some of which is listed at the end.

2.2 Finite Difference Method. In the finite difference method, as the name would indicate, one uses differences of functions, variables, and the like, in order to obtain approximate solutions to mostly differential equations. In finding numerical solutions, the difference operators are used in a manner similar to that of differential operators in the differential equations (Hovanessian 1976).

In order to define various difference operators, we consider a function $y = f(x)$ as shown in Figure 15 with equal intervals Δx for an independent variable x .

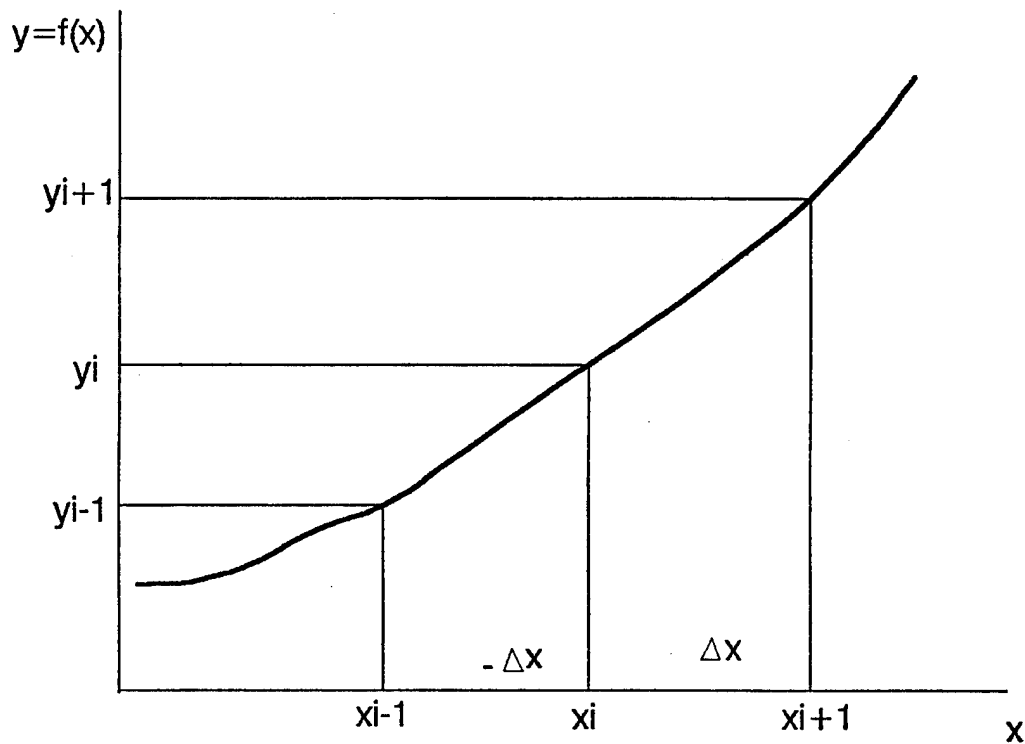

Figure 15. Definition of the equal interval Δx from which the forward, the backward, and the central differences of $y(x)$ are defined.

There are three kind of differences: the forward, the backward, and the central difference, respectively.

The first forward difference of y_i is defined as

$$\Delta y_i = y_{i+1} - y_i, \quad (2.2.1)$$

where formally Δ is the forward difference operator. Clearly, for the second forward difference operator we have

$$\Delta^2 y_i = \Delta(\Delta y_i) = \Delta y_{i+1} - \Delta y_i = y_{i+2} - 2y_{i+1} + y_i. \quad (2.2.2)$$

By similar reasoning one obtains for the third forward difference operator expression

$$\Delta^3 y_i = \Delta(\Delta^2 y_i) = y_{i+3} - 3y_{i+2} + 3y_{i+1} - y_i. \quad (2.2.3)$$

These two equations clearly exhibit the operational nature of Δ .

The first backward difference of y_i is defined as

$$\nabla y_i = y_i - y_{i-1}, \quad (2.2.4)$$

where formally ∇ is the backward difference operator. The second backward difference operator can be obtained from the first:

$$\nabla^2 y_i = \nabla(\nabla y_i) = \nabla y_i - \nabla y_{i-1} = y_i - 2y_{i-1} + y_{i-2}. \quad (2.2.5)$$

Similarly, the third backward difference becomes

$$\nabla^3 y_i = \nabla(\nabla^2 y_i) = y_i - 3y_{i-1} + 3y_{i-2} - y_{i-3}. \quad (2.2.6)$$

The first central difference of y_i is defined as

$$\delta y_i = y_{i+\frac{1}{2}} - y_{i-\frac{1}{2}}, \quad (2.2.7)$$

where δ formally denotes the central difference operator. The second central difference operator is obtained from the first:

$$\begin{aligned}\delta^2 y_i &= \delta(\delta y_i) = \delta\left(y_{i+\frac{1}{2}} - y_{i-\frac{1}{2}}\right) \\ &= \left(y_{i+\frac{1}{2}+\frac{1}{2}} - y_{i+\frac{1}{2}-\frac{1}{2}}\right) - \left(y_{i-\frac{1}{2}+\frac{1}{2}} - y_{i-\frac{1}{2}-\frac{1}{2}}\right) \\ &= y_{i+1} - 2y_i + y_{i-1}.\end{aligned}\tag{2.2.8}$$

Similarly, third and fourth central difference operators are obtained:

$$\delta^3 y_i = \delta(\delta^2 y_i) = y_{i+\frac{3}{2}} - 3y_{i+\frac{1}{2}} + 3y_{i-\frac{1}{2}} - y_{i-\frac{3}{2}},\tag{2.2.9}$$

$$\delta^4 y_i = \delta(\delta^3 y_i) = y_{i+2} - 4y_{i+1} + 6y_i - 4y_{i-1} + y_{i-2}.\tag{2.2.10}$$

Denoting generically with Ω the three difference operators, one verifies directly that

$$\Omega^2(\Omega y_i) = \Omega(\Omega^2 y_i).\tag{2.2.11}$$

By induction one further obtains

$$\Omega^r \Omega^s = \Omega^s \Omega^r = \Omega^{r+s}, \quad \Omega^0 = 1,\tag{2.2.12}$$

and very important distribution laws

$$\Omega(y_i + z_i) = \Omega y_i + \Omega z_i,\tag{2.2.13}$$

$$\Omega \text{const} y_i = \text{const} \Omega y_i.\tag{2.2.14}$$

Next, we wish to establish the relationship between difference and differential operators. To this end, define first the symbolic difference operator E as follows:

$$E y_i = y_{i+1}, E^{-1} y_i = y_{i-1}, E^{\pm \frac{1}{2}} y_i = y_{i \pm \frac{1}{2}}. \quad (2.2.15)$$

One should notice that these relations are consistent with each other. Some important relations involving E are:

$$E \text{ const} = \text{const } E,$$

$$E \Omega = \Omega E, E^n \Omega = \Omega E^n, \quad (2.2.16)$$

where const and n are independent of x . Using these relations, one obtains difference operators Δ , ∇ , and δ in terms of E

$$\Delta y_i = (E - 1)y_i \mapsto \Delta = E - 1,$$

$$\nabla y_i = (1 - E^{-1})y_i \mapsto \nabla = 1 - E^{-1},$$

$$\delta y_i = \left(E^{\frac{1}{2}} - E^{-\frac{1}{2}} \right) y_i \mapsto \delta = E^{\frac{1}{2}} - E^{-\frac{1}{2}}. \quad (2.2.17)$$

The relation between the forward difference operators and the differential operator is obtained by writing Taylor's series expansion of the function $f(x + h)$ about x .

$$f(x + h) = \sum_{n=0}^{\infty} \frac{h^n}{n!} D^n f(x) = e^{hD} f(x), D = \frac{d}{dx}. \quad (2.2.18)$$

But

$$E f(x) = f(x + h) \mapsto E = e^{hD}, D = \frac{\ln E}{h}. \quad (2.2.19)$$

Now we are ready to find a relationship between difference operators and D. Starting with Δ , from relation (2.2.17) we have

$$\Delta = E - 1 = e^{hD} - 1, D = \frac{1}{h} \ln(1 + \Delta). \quad (2.2.20)$$

The useful relations are obtained when one expands (2.2.20), yielding:

$$\Delta = hD + \frac{h^2}{2!} D^2 + \frac{h^3}{3!} D^3 + \dots \quad (2.2.21)$$

and

$$D = \frac{1}{h} \left(\Delta - \frac{\Delta^2}{2} + \frac{\Delta^3}{3} - \frac{\Delta^4}{4} + \dots \right). \quad (2.2.22)$$

Higher-order derivative and forward difference operators are obtained by taking various powers of (2.2.20), resulting in the following second- and higher-order operator equations:

$$\Delta^2 = h^2 D^2 + h^3 D^3 + \frac{7}{12} h^4 D^4 + \dots, \quad (2.2.23a)$$

$$\Delta^3 = h^3 D^3 + \frac{3}{2} h^4 D^4 + \frac{5}{4} h^5 D^5 + \dots \quad (2.2.23b)$$

$$D^2 = \frac{1}{h^2} \left(\Delta^2 - \Delta^3 + \frac{11}{12} \Delta^4 - \frac{5}{6} \Delta^5 + \dots \right), \quad (2.2.24a)$$

$$D^3 = \frac{1}{h^3} \left(\Delta^3 - \frac{3}{2} \Delta^4 - \frac{5}{6} \Delta^5 + \dots \right), \quad (2.2.24b)$$

$$D^4 = \frac{1}{h^4} \left(\Delta^4 - 2\Delta^5 + \frac{17}{6} \Delta^6 - \dots \right). \quad (2.2.24c)$$

Equations (2.2.21) to (2.2.24) can be used to find the differentials of functions in terms of available functional values. For example, neglecting errors of order h and higher, $D^2 y_i$ can be obtained from (2.2.24a). Dropping Δ^3 and higher-order terms from this equation and using (2.2.2), one obtains

$$D^2 y_i \cong \frac{1}{h^2} \Delta^2 y_i = \frac{1}{h^2} (y_{i+2} - 2y_{i+1} + y_i). \quad (2.2.25a)$$

A faster way to obtain this result is to use (2.2.20):

$$D^2 y_i \cong \frac{1}{h^2} \Delta^2 y_i = \frac{1}{h^2} (1 - E)^2 y_i = \frac{1}{h^2} (y_i - 2y_{i+1} + y_{i+2}). \quad (2.2.25b)$$

The backward difference operator can be obtained in terms of the differential operator D with the aid of equation (2.2.17). In fact, from the relations (2.2.17) and (2.2.19) one has

$$\nabla = 1 - E^{-1} = 1 - e^{-hD}, \quad D = -\frac{1}{h} \ln(1 - \nabla). \quad (2.2.26,27)$$

Taylor's expansion yields for ∇ the result

$$\nabla = hD - \frac{h^2}{2!} D^2 + \frac{h^3}{3!} D^3 - \dots \quad (2.2.28a)$$

Taking higher powers of relations (2.2.21a,b) we obtained higher-order difference and derivative operators. These are summarized as follows:

$$\nabla^2 = h^2 D^2 - h^3 D^3 + \frac{7}{12} h^4 D^4 - \dots, \quad (2.2.28b)$$

$$\nabla^3 = h^3 D^3 - \frac{3}{2} h^4 D^4 + \frac{5}{4} h^5 D^5 - \dots; \quad (2.2.28c)$$

$$D = \frac{1}{h} \left(\nabla + \frac{\nabla^2}{2} + \frac{\nabla^3}{3} + \frac{\nabla^4}{4} + \dots \right), \quad (2.2.29a)$$

$$D^2 = \frac{1}{h^2} \left(\nabla^2 + \nabla^3 + \frac{11}{12} \nabla^4 + \frac{5}{6} \nabla^5 + \dots \right), \quad (2.2.29b)$$

$$D^3 = \frac{1}{h^3} \left(\nabla^3 + \frac{3}{2} \nabla^4 + \frac{7}{4} \nabla^5 + \dots \right), \quad (2.2.29c)$$

$$D^4 = \frac{1}{h^4} \left(\nabla^4 + 2 \nabla^5 + \frac{17}{6} \nabla^6 + \dots \right). \quad (2.2.29d)$$

The equations relating the central difference operator δ and differential operator D are obtained using equations (2.2.15) and (2.2.19).

$$\delta = E^{\frac{1}{2}} - E^{-\frac{1}{2}}, \quad E = e^{hD}, \quad d = \frac{1}{h} \ln E. \quad (2.2.30)$$

In addition, it is customary to define the mean operator μ as follows:

$$\mu = \frac{1}{2} \left(E^{\frac{1}{2}} + E^{-\frac{1}{2}} \right). \quad (2.2.31)$$

This implies

$$\mu\delta = \frac{1}{2}(E - E^{-1}) = \frac{1}{2}(e^{hD} - e^{-hD}) = \sinh(hD). \quad (2.2.32)$$

Applying the difference operator $\mu\delta$ to y_i , we obtain

$$(\mu\delta)y_i = \frac{1}{2}(y_{i+1} - y_{i-1}). \quad (2.2.33)$$

From (2.2.31), we have

$$\mu^2 = \frac{1}{4}(E + E^{-1} + 2) = 1 + \frac{\delta^2}{4}. \quad (2.2.34)$$

The Taylor series expansion of the right-hand side of (2.2.32) yields

$$\mu\delta = hD + \frac{h^3 D^3}{6} + \frac{h^5 D^5}{120} + \dots \quad (2.2.35)$$

The general expression for δ^n , where $n = 1, 2, 3, \dots$, can be obtained from relation (2.2.30).

$$\begin{aligned} \delta &= e^{\frac{hD}{2}} - e^{-\frac{hD}{2}} = 2 \sinh \frac{hD}{2}, \\ \delta^n &= 2^n \sinh^n \frac{hD}{2}. \end{aligned} \quad (2.2.36)$$

By similar reasoning, we obtain from (2.2.31) for $n = 1, 2, 3, \dots$,

$$\begin{aligned}\mu &= \cosh \frac{hD}{2}, \\ \mu^n &= \cosh^n \frac{hD}{2}.\end{aligned}\tag{2.2.37}$$

Using the combinations of the aforementioned relations, we can obtain expressions for higher powers of central difference operators, as for example

$$\begin{aligned}\mu \delta^3 &= (\mu \delta) \delta^2 = \sinh hD \frac{1}{2} \sinh^2 \frac{hD}{2} \\ &= h^3 D^3 + \frac{h^5 D^5}{4} + \frac{h^7 D^7}{40} + \dots\end{aligned}\tag{2.2.38}$$

Similarly, from (2.2.36) one obtains

$$\delta^4 = h^4 D^4 + \frac{h^6 D^6}{6} + \frac{h^8 D^8}{80} + \dots\tag{2.2.39}$$

The differential operators D are obtainable in terms of central difference operators δ . For example, from (2.2.32) and (2.2.35) we have

$$D = \frac{1}{h} \sinh^{-1} \mu \delta = \frac{1}{h} \left(\mu \delta - \frac{\mu \delta^3}{6} + \frac{\mu \delta^5}{30} - \dots \right),\tag{2.2.40}$$

where the right side is obtained from the Taylor series expansion of $\sinh^{-1} \mu \delta$. Similarly,

$$D^2 = \frac{1}{h^2} \left(\delta^2 - \frac{\delta^4}{12} + \frac{\delta^6}{90} - \dots \right).\tag{2.2.41}$$

$$D^3 = \frac{\mu}{h^3} \left(\delta^3 - \frac{\delta^5}{4} + 7 \frac{\delta^7}{120} - \dots \right).\tag{2.2.42}$$

$$D^4 = \frac{1}{h^4} \left(\delta^4 - \frac{\delta^6}{6} + \frac{7\delta^8}{120} - \dots \right). \quad (2.2.43)$$

Although not exclusively true for all cases, when numerically solving differential equations, one tends to express differential operators D in terms of difference operators δ .

As an example of application of the aforementioned equations with difference operators δ , we seek the numerical solution of the differential equation

$$\frac{d^2 y}{dt^2} + \frac{dy}{dt} + y = 0; \quad y(t=0) = 1, \quad (dy/dt)(t=0) = 0. \quad (2.2.44a,b)$$

Using differential operator $D = d/dt$, this differential equation translates into

$$D^2 y_i + D y_i + y_i = 0; \quad y_0 = 1, \quad D y_0 = 0. \quad (2.2.45a,b,c)$$

Denoting $\Delta t = h$ and containing relations (2.2.30) and (2.2.31) with relations (2.2.40) to (2.2.43), we obtain

$$D y_i = \frac{y_{i+1} - y_{i-1}}{2h}; \quad D^2 y_i = \frac{y_{i-1} - 2y_i + y_{i+1}}{h^2}, \quad e = O(h^2), \quad (2.2.46a,b)$$

where e stands for "error" and denotes the order in h of terms that are neglected. Substituting relations (2.2.46) into (2.2.45a), we obtain a recursive relation for y_{i+1} , as follows:

$$y_{i+1} = \frac{1}{2+h} \left[(4 - 2h^2) y_i + (h - 2) y_{i-1} \right]. \quad (2.2.47)$$

This equation gives y_{i+1} , providing the values of y_i and y_{i-1} are available; for these the initial conditions will be helpful. The condition (2.2.45c) gives

$$Dy_0 = \frac{y_1 - y_{-1}}{2h} = 0; y_{-1} = y_1. \quad (2.2.48)$$

We inserted y_{-1} in order to make the derivative at y_0 symmetrical. Formally, y_{-1} can be related to the second constant of integration. In any case, setting $i = 0$ in (2.2.47) and using $y_0 = 1$ and $y_{-1} = y_1$, we obtain

$$y_1 = \frac{1}{2+h} \left[(4 - 2h^2) + (h - 2)y_1 \right] \rightarrow y_1 = 1 - \frac{h^2}{2}. \quad (2.2.49a,b)$$

Selecting the value for the increment h , we obtain a numerical value for y_1 . Thus we will have y_0 and y_1 , and we can proceed with the calculation of y_2 by setting $i = 2$ in (2.2.47). Similarly, we can calculate y_3, y_4 , and so on. The values $y_0, y_1, y_2, y_3, \dots$ will represent the solution of the differential equation (2.2.44) at discrete time intervals of $i \Delta t = ih$ where $i = 0, 1, 2, 3, \dots$.

Already we see the possible problems with the finite difference method solutions of differential equations. If Δt is too small, a great number of iterations will be required to obtain the value of y at a given time. On the other hand, if Δt is too large, since the error is of the order of $(\Delta t)^2 \equiv h^2$, the error in each application of (2.2.47) may accumulate, resulting in large errors in the solution.

Next we discuss a simple case of numerical solution of a differential equation starting from the Taylor series expansion. Consider the first-order differential equation

$$y' = \frac{dy}{dx} = f(x, y), \quad (2.2.50)$$

with the initial condition $y = y_0$ at $x = x_0$. The Taylor series expansion of y about x_0 , using an increment Δx , yields

$$y(x_0 + \Delta x) = y_0 + \Delta x y_0' + \frac{1}{2!} (\Delta x)^2 y_0'' + \dots \quad 2.2.51$$

Taking the first two terms from the series, we obtain (see Figure 16),

$$\begin{aligned}
 y(x_0 + \Delta x) &= y_0 + \Delta x y_0' \\
 &\equiv y_0 + \Delta x f(x_0, y_0).
 \end{aligned}
 \tag{2.2.52}$$

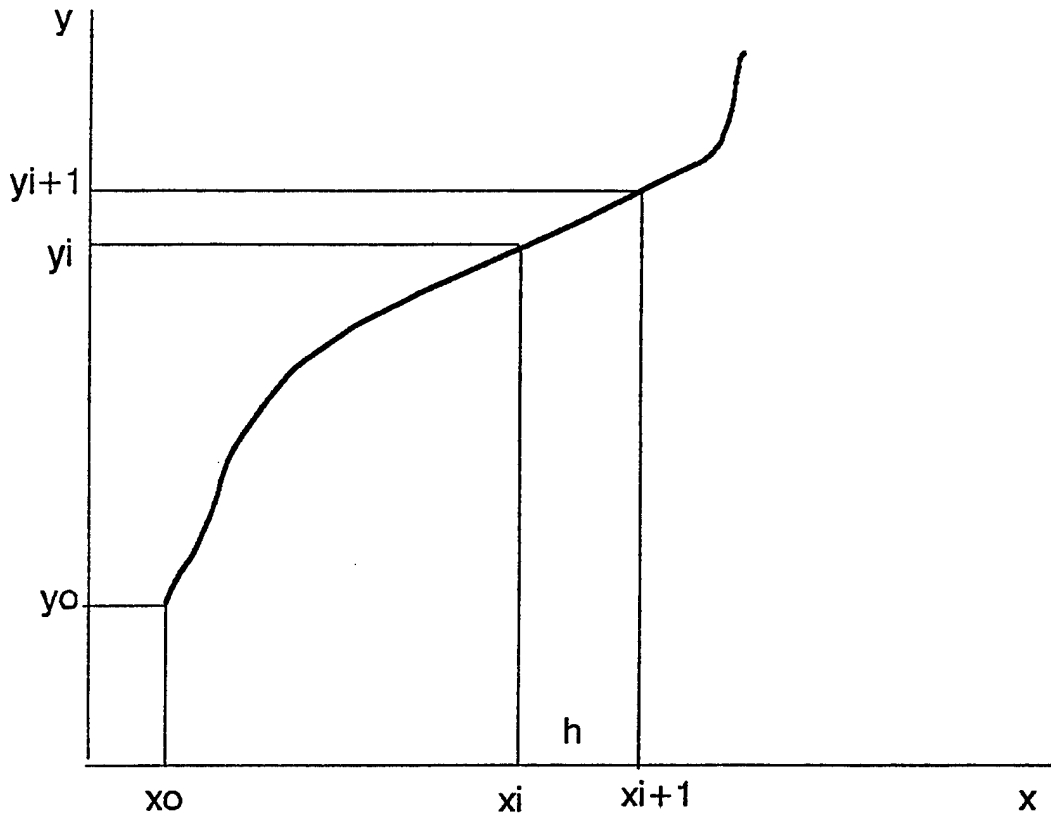

Figure 16. Graphic representation of the evolution of $y(x)$, the solution of the first-order differential equation, in terms of $h = \Delta x$.

Denoting $x_1 = x_0 + \Delta x$ and $x_2 = x_1 + \Delta x$ with corresponding $y_1 = y(x_0 + \Delta x)$ and $y_2 = y(x_1 + \Delta x)$, we may write

$$\begin{aligned}
 y_1 &= y_0 + \Delta x f(x_0, y_0), \\
 y_2 &= y_1 + \Delta x f(x_1, y_1), \\
 &\dots \\
 y_{n+1} &= y_n + \Delta x f(x_n, y_n).
 \end{aligned}
 \tag{2.2.53}$$

The error is simply the next term in the expansion (2.2.51):

$$e = \frac{(\Delta x)^2}{2} y' = \frac{(\Delta x)^2}{2} \left(\frac{\partial f}{\partial x} + f \frac{\partial f}{\partial y} \right). \quad (2.2.54)$$

The error in this case is directly proportional to the square of the increment Δx and to the combination of function $f(x,y)$ and its partial derivatives, with respect to x and y at the position $(x,y) = (x_i, y_i)$, $i = 1, 2, 3, \dots, n$.

Example: Consider the numerical solution of the first-order differential equation

$$\frac{dy}{dx} = y' = -y \text{ with } y = 1 \text{ at } x = 0. \quad (2.2.55a)$$

The solution is given exactly as

$$y = e^{-x}. \quad (2.2.55b)$$

Denoting with $\Delta x = h$, from relations (2.2.53), one immediately sees that

$$y_n = 1 - nh, \quad (2.2.56)$$

which is a good approximation of exact solution (2.2.55b) if $x_n \equiv nh \ll x_n^2$.

Another way to solve this differential equation numerically is to use the finite difference representation. Namely, the derivative of y at x_n is equal to the slope of the curve of Figure 16 at this point. This slope can be represented by either

$$y'_n = (y_{n+1} - y_n)/h, \quad (2.2.57)$$

or

$$y_n' = (y_{n+1} - y_{n-1})/2h, \quad (2.2.58)$$

where, of course, $h = \Delta x$. One recognizes equations (2.2.57) and (2.2.58) as the forward and central difference equations of the first derivative. Therefore, consistent with relation (2.2.55a) one may write

$$(y_{n+1} - y_n)/h = -y_n; \quad y_0 = 1, \quad h = \frac{1}{4}, \quad (2.2.59)$$

$$(y_{n+1} - y_{n-1})/2h = -y_n; \quad y_0 = 1, \quad y_1 = e^{-1/4}, \quad h = \frac{1}{4}. \quad (2.2.60)$$

Formulation (2.2.59) is the forward difference formulation with increment $h = 0.25$. Formulation (2.2.60), however, is the central difference formulation, also with $h = 0.25$. Now, in formulation (2.2.59), we can set $n = 0$ and solve for y_1 . Formulation (2.2.60) will require both y_0 and y_1 to start the problem and solve for y_2 . In most cases, y_1 can be evaluated by using the Taylor series expansion.

Of course, there are other finite difference methods to numerically solve differential equations; one such method is the famous Runge-Kutta method. Discussing all these methods is beyond the scope of this report.

2.3 Finite Volume Method. Finally we address briefly the finite volume method. In the finite volume method (Hyman, Knapp, and Scovel 1992), the average values of a function over local mesh cells are taken as unknowns; discrete approximations of the divergence, gradient, and rotor (curl) operators are defined using general forms of Stoke's theorem.

To get a feel for the finite volume method, consider a physically motivated system of partial differential equations derived from a limiting process applied to integral equations. For example, a quantity ρ (charge density or fluid density) is conserved under the flow of a conservation law if the amount of ρ contained in any fixed volume Ω is due entirely to the flux of \vec{j} (current density) across the boundary $\sigma(\Omega)$ of the volume Ω ; one should realize that here the terms "volume" and "surface" are not

necessarily restricted to just the three-dimensional (3-D) space. For the sake of simplicity, however, here we do deal in the 3-D space, and the conservation law can be expressed in integral form as

$$\frac{d}{dt} \int_{\Omega} \rho dV = \oint_{\sigma(\Omega)} \vec{j} \cdot d\vec{\sigma} , \quad (2.3.1)$$

where $d\vec{\sigma}$ is the surface element vector whose direction is outward normal to the boundary. Moving the time derivative under the integral sign and applying the divergence (Gauss) theorem, equation (2.3.1) can be rewritten as

$$\int_{\Omega} (\partial_t \rho + \nabla \cdot \vec{j}) dV = 0. \quad (2.3.2)$$

If we let the volume Ω shrink to a point, we obtain the partial differential equation

$$\partial_t \rho + \nabla \cdot \vec{j} = 0 , \quad (2.3.3)$$

providing that at every point ρ and \vec{j} are differentiable.

When numerically solving equation (2.3.1) it is natural to stop the limiting process at the local mesh spacing and solve (2.3.2) where the control volumes Ω are the local mesh cells. Specifically, in a small time-invariant 3-D control volume Ω , we rewrite the integral equation (2.3.2) as

$$\frac{\partial}{\partial t} (\rho)_{av3} + (\nabla \cdot \vec{j})_{av3} = 0 ,$$

where $(\dots)_{av3}$ and $(\nabla \cdot)_{av3}$ represent a 3-D cell average; the divergence theorem is applied in computing $(\nabla \cdot \vec{j})_{av3}$ by acting on face-average normal components of fluxes:

$$\begin{aligned}
(\nabla \cdot \vec{j})_{av3} &:= \frac{1}{\text{Vol}(\Omega)} \int_{\Omega} \nabla \cdot \vec{j} \, d\text{Vol} \\
&= - \frac{1}{\text{Vol}(\Omega)} \oint_{\sigma(\Omega)} \vec{j} \cdot d\vec{\sigma} \\
&= - \frac{1}{\text{Vol}(\Omega)} \sum_i^r A_i (j_i)_{av2}.
\end{aligned} \tag{2.3.4}$$

Here the time-independent control volume Ω is bordered by mesh points. Its boundary is the union of I ($i = 1, 2, \dots, I$) distinct pieces, $\sigma(\Omega) = \cup \sigma(\Omega_i)$. Furthermore, A_i is the area vector of the i th piece, and $(j_i)_{av2}$ may be interpreted as the normal component of \vec{j} over the i th piece given by

$$(j_i)_{av2} = \frac{1}{A_i} \oint_{\sigma(\Omega_i)} \vec{j} \cdot d\vec{\sigma}(\Omega_i). \tag{2.3.5}$$

The central idea behind the finite volume method is to accurately approximate $(j_i)_{av2}$ and use relation (2.3.4) to define a discrete approximation of $(\nabla \cdot \vec{j})_{av3}$, which, in turn, defines $\partial(\rho)_{av3}/\partial t$.

In fact, the finite volume method can be directly applied to time; integrating (2.3.2) from t_n to t_{n+1} we obtain

$$\int_{t_n}^{t_{n+1}} dt \int_{\Omega} (\partial_t \rho + \nabla \cdot \vec{j}) \, d\text{Vol} = 0, \tag{2.3.6}$$

or, using (2.3.4), one further obtains,

$$\begin{aligned}
(\rho)_{av3}^{n+1} &= (\rho)_{av3}^n - \int_{t_n}^{t_{n+1}} (\nabla \cdot \vec{j})_{av3} dt \\
&= (\rho)_{av3}^n + \frac{1}{\text{Vol}(\Omega)} \sum_i \int_{t_n}^{t_{n+1}} A_i (j_i)_{av2} dt.
\end{aligned}
\tag{2.3.7}$$

The fluxes associated with $(j_i)_{av2}$ are assumed to be known as a function of time; they might be approximated directly by incorporating past time levels in standard linear multistep methods (Hyman, Knapp, and Scovel 1992); of course, there is nothing wrong in evaluating these fluxes by the finite difference of the finite element method if, for example, \vec{j} is given by some other equation (the Schroedinger equation, for instance).

This was a simple "introductory" example intended to give a "flavor" and the basic idea of the finite volume method. It is beyond the scope of this report to go into more details of this rather new and complex method, which, at least presently, can be found only in research literature.

3. COMPARISONS OF METHODS

Today, both finite element and finite difference methods are used rather extensively in numerically solving the most complex problems, as in calculating the electromagnetic fields for complex structures or in calculating the electromagnetic field effects on structures with very complex geometries. However, it is the finite element method that is today considered to be a superior method, particularly when the question of efficiency is posed for solving a variety of practical problems. One of the main attractions of this method is that once the method is set up, that is, the computer program is written which generates the interpolation functions, it can be used for other problems by changing the input data. On a historical note, the method was first developed in 1956 for the analysis of aircraft structural problems. Today, so much work is done with the finite element method that, in fact, this method has become one of the research areas of applied mathematics itself.

The finite difference method, of course, is much older than the finite volume method. In fact, it is as old as differential calculus itself. This means that it was in use well before computers became available. However, each advance in computer technology makes the finite difference method more

interesting in that more and more complex problems can be treated. In fact, being "simpler" than the finite element method, the finite difference method is quite often the preferred method when the accuracy of results is not essential.

In fact, rather recently, at the Stanford Linear Accelerated Center, where the solutions of Maxwell's equations for electromagnetic fields propagating in cavities with symmetric periodic structures and structures with axial symmetry were sought, it was found that the finite element method is much more accurate than the finite difference method (Nelson 1992, 1993). Denoting generically with F the solution for an electromagnetic field, one finds that the smallest values for $|\delta F/F|$ are

$$|\delta F/F| = 10^{-3}, 10^{-5},$$

for the finite difference and finite element methods, respectively. Here δF represents the deviation from the experimentally measured field F . Furthermore, taking into account that the finite element method is capable of finding rather accurately the solutions for electromagnetic fields, even when the structures have sharp edges, one sees that, overall, the finite element method is superior to the finite difference method. However, the finite element method, because it follows rigorous procedures, can be rather complex when deriving numerical algorithms for solutions, particularly when compared to the finite difference method. Hence, when analyzing technical and scientific problems, these two methods should not be considered as mutually exclusive, but rather both of them should be used, depending on needed accuracy and urgency of solutions.

As far as the finite volume method is concerned, its accuracy depends on specifics of other computational methods that are used after the generalized Stoke's theorem has been applied. The thing to emphasize here is that the generalized Stoke's theorem in the finite volume method effectively reduces the number of computational dimensions; a solution that is being sought at a small volume (which mimics a point) is reduced with the help of the generalized Stoke's theorem to computations over sides bordering a small volume.

4. POTENTIAL APPLICATIONS, DISCUSSIONS, AND CONCLUSIONS

Finite volume and finite difference methods, no doubt, can be used to obtain adequate approximate solutions of electromagnetic fields. In particular, one should be able to predict the effects of nuclear-burst-generated electromagnetic effects on defense systems, such as the scattering of the electromagnetic pulse off combat vehicles as a whole and electronic components, sensors, etc., in particular.

One of the newer subjects where, in particular, the finite element method could be used is the statistical modeling of the Gulf War Syndrome. The aim here is to obtain the probabilistic formulation of the syndrome itself. Specifically, for each unit associated with a particular geographic location based on data from the U.S. Army & Joint Services Support Group and the Environmental Epidemiological Service from the Veterans Administration, the soldier probability distribution function of symptoms (here symptom means symptom and illness) would be constructed with the help of six finite element interpolation functions (corresponding to six discrete symptoms). Because of these interpolation functions, the soldier probability distribution function becomes an analytical function in symptom-variable. This, in turn, allows one to calculate the average soldier symptom as a function of the continuous symptom-variable, allowing us to find the range of symptoms that very ill soldiers have. Turning now to the database we can rank specific symptoms according to the frequency of their occurrence. The six most frequent ones define the syndrome which now the medical doctors can study to determine the common causes of the Gulf War Syndrome for each particular geographic region.

Another new project where actually the finite volume method could be employed is the "Rotor Wash Model" project. Here the idea is to develop analytical techniques which would replicate rotorcraft aerodynamics at specified positions around the helicopter fuselage in order to predict the infiltration of diverse kinds of agents on and into helicopters. It appears natural to model the flow of agents with the finite volume method by employing the Stoke's theorem when studying the flow of agents.

Finally, we notice that "Aerosol and Vapor Infiltration Modeling" is another important area where, in addition to the finite element and finite difference methods, the finite volume method could play a very important role. Here, one is striving to develop a predictive methodology that could determine levels of vapor concentration and liquid deposition in and on a variety of structures. The fluid dynamics, with which one is dealing here, are natural for utilization of the finite volume method. This again comes from

the fact that Stoke's theorem, on which the finite volume method is based, enters very naturally into the importance of the description of fluid motion.

Hopefully, the few examples mentioned here show the importance of the methods briefly exposed in the main body of the text. It appears that the finite volume method is not yet widely accepted by the computing community. The reason for this is that the finite volume method, when compared to the other two methods, is not a "pure" method but rather a "composite" method consisting of Stoke's theorem and the finite element and/or the finite difference methods. Judging by the amount of literature available on various methods (see the Appendix for details) it is evident that the finite element method is far the most popular and perhaps, the most important approximation method for evaluations in vulnerability/ lethality analysis.

5. REFERENCES

- Dhatt, G., and G. Touzot. The Finite Element Method Displayed. New York: Wiley, 1984.
- Hovanessian, S. A. Computational Methods in Engineering. Lexington, MA: Lexington Books, 1976.
- Hyman, J. M., R. J. Knapp, and J. C. Scovel. Physica D, vol. 60, p. 112, 1992.
- Nelson, E. M. "A Finite Element Field Solver for Dipole Modes." SLAC-PUB-5881, Stanford Linear Accelerator Center, Stanford University, CA, August 1992.
- Nelson, E. M. "Exploiting Periodicity and Other Structural Symmetries in Field Solvers." SLAC-PUB-6061, Stanford Linear Accelerator Center, Stanford University, CA, February 1993.

INTENTIONALLY LEFT BLANK.

BIBLIOGRAPHY

LITERATURE ON THE FINITE ELEMENT METHOD

- Akin, J. E. Application and Implementation of Finite Element Methods. New York: Academic Press, 1982.
- Axelsson, O., and V. A. Barker. Finite Element Solution of Boundary Value Problems: Theory and Computation. Orlando, FL: Academic Press, 1984.
- Becker, E. B., and J. T. Oden. Finite Elements: An Introduction. Englewood Cliffs, NJ: Prentice-Hall, 1981.
- Bickford, W. B. A First Course in the Finite Element Method. Irwin, IL: Homewood, 1990.
- Brauer, J. R. What Every Engineer Should Know About Finite Element Analysis. New York: M. Dekker, 1993.
- Chandrupatla, T. R., and A. D. Belegundu. Introduction to Finite Elements in Engineering. Englewood Cliffs, NJ: Prentice Hall, 1991.
- Chariand, M. V. K., and P. Silvester. Finite Elements in Electrical and Magnetic Field Problems. New York: Wiley, 1980.
- Chung, T. J. Finite Element Analysis in Fluid Dynamics. New York: McGraw-Hill, 1987.
- Connor, J. J., and C. A. Brebbia. Finite Element Techniques for Fluid Flow. Boston: Newnes-Butterworths, 1976.
- Cook, R. P. Concepts and Applications of Finite Element Analysis. New York: Wiley, 1981.
- Fagan, M. J. Finite Element Analysis: Theory and Practice. New York: Wiley, 1992.
- Gallagher, R. H. Finite Element Analysis: Fundamentals. Englewood Cliffs, NJ: Prentice-Hall, 1975.
- Grandin, H. Fundamentals of the Finite Element Method. New York: Macmillan, 1986.
- Huebner, K. H., and E. A. Thornton. The Finite Element Method for Engineers. New York: Wiley, 1982.
- Irons, B., and N. Shrive. Finite Element Primer. New York: E. Horwood, 1983.
- Jian-Ming Jin. The Finite Element in Electromagnetic. New York: Wiley, 1993.
- Livesly, R. K. Finite Elements: An Introduction for Engineers. New York: Cambridge University Press, 1983.

- Logan, D. L. A First Course in the Finite Element Method. 2nd ed. Boston: PWS-Kent Publication Company, 1992.
- Mitchell, A. R., and R. Wait. The Finite Element Method in Partial Differential Equations. New York: Wiley, 1978.
- Ottosen, N. S., and H. Peterson. Introduction to the Finite Elements in Engineering. New York: Prentice Hall, 1992.
- Rao, S. S. The Finite Element Method in Engineering. New York: Pergamon Press, 1982.
- Reddy, J. N. An Introduction to the Finite Element Method. New York: McGraw-Hill, 1984.
- Rockey, K. C. The Finite Element Method: A Basic Introduction. New York: Wiley, 1983.
- Ross, C. T. F. Finite Element Programs for Axisymmetric Problems in Engineering. New York: E. Horwood, 1984.
- Segerlind, L. J. Applied Finite Element Analysis. New York: Wiley, 1976.
- Silvester, P., and R. L. Ferrari. Finite Elements for Electrical Engineers. New York: Cambridge University Press, 1983.
- Wait, R., and A. R. Mitchell. Finite Element Analysis and Applications. New York: Wiley, 1985.
- White, R. E. An Introduction to the Finite Element Method With Applications to Nonlinear Problems. New York: Wiley, 1985.
- Zienkiewicz, O. C. The Finite Element Method, vols. 1 and 2. New York: McGraw-Hill, 1991.

LITERATURE ON THE FINITE DIFFERENCE METHOD

- Chou, Yu-lin. Applications of Discrete Functional Analysis to the Finite Difference Method. New York: Pergamon Press, 1990.
- Kunz, Karl S., and R. J. Luebbers. The Finite Difference Time Domain Method for Electromagnetic, vols. 1 and 2. Boca Raton, FL: CRS Press, 1993.
- Levy, H., and F. Lessman. Finite Difference Equations. New York: Dover Publications, 1992.
- Mitchell, A. R., and D. F. Griffiths. The Finite Difference Method in Partial Differential Equations. New York: Wiley, 1980.
- Schwab, A. J. Field Theory Concepts: Electromagnetic Fields, Maxwell's Equations, Grad, Curl, Div, Etc.: Finite Element Method, Finite Difference Method, Charge Simulation Method, Monte Carlo Method." Berlin, NY: Springer-Verlag, 1980.

LITERATURE ON THE FINITE VOLUME METHOD

Osher, S., and F. Solomon. Mathematical Computations, vol. 38, p. 339, 1982.

Vinokur, M. Journal of Computational Physics, vol. 81, p. 1, 1989.

INTENTIONALLY LEFT BLANK.

NO. OF
COPIES ORGANIZATION

2 ADMINISTRATOR
DEFENSE TECHNICAL INFO CTR
ATTN DTIC DDA
CAMERON STATION
ALEXANDRIA VA 22304-6145

1 DIRECTOR
US ARMY RESEARCH LAB
ATTN AMSRL OP SD TA
2800 POWDER MILL RD
ADELPHI MD 20783-1145

3 DIRECTOR
US ARMY RESEARCH LAB
ATTN AMSRL OP SD TL
2800 POWDER MILL RD
ADELPHI MD 20783-1145

1 DIRECTOR
US ARMY RESEARCH LAB
ATTN AMSRL OP SD TP
2800 POWDER MILL RD
ADELPHI MD 20783-1145

ABERDEEN PROVING GROUND

5 DIR USARL
ATTN AMSRL OP AP L (305)

<u>NO. OF COPIES</u>	<u>ORGANIZATION</u>
1	OSD OUSD AT STRT TAC SYS ATTN DR SCHNEITER 3090 DEFNS PENTAGON RM 3E130 WASHINGTON DC 20301-3090
1	ODDRE AT ACQUISITION AND TECH ATTN DR GONTAREK 3080 DEFENSE PENTAGON WASHINGTON DC 20310-3080
1	ASST SECY ARMY RESEARCH DEVELOPMENT ACQUISITION ATTN SARD ZD RM 2E673 103 ARMY PENTAGON WASHINGTON DC 20310-0103
1	ASST SECY ARMY RESEARCH DEVELOPMENT ACQUISITION ATTN SARD ZP RM 2E661 103 ARMY PENTAGON WASHINGTON DC 20310-0103
1	ASST SECY ARMY RESEARCH DEVELOPMENT ACQUISITION ATTN SARD ZS RM 3E448 103 ARMY PENTAGON WASHINGTON DC 20310-0103
1	ASST SECY ARMY RESEARCH DEVELOPMENT ACQUISITION ATTN SARD ZT RM 3E374 103 ARMY PENTAGON WASHINGTON DC 20310-0103
1	UNDER SEC OF THE ARMY ATTN DUSA OR RM 2E660 102 ARMY PENTAGON WASHINGTON DC 20310-0102
1	ASST DEP CHIEF OF STAFF OPERATIONS AND PLANS ATTN DAMO FDZ RM 3A522 460 ARMY PENTAGON WASHINGTON DC 20310-0460
1	DEPUTY CHIEF OF STAFF OPERATIONS AND PLANS ATTN DAMO SW RM 3C630 400 ARMY PENTAGON WASHINGTON DC 20310-0400

<u>NO. OF COPIES</u>	<u>ORGANIZATION</u>
1	ARMY RESEARCH LABORATORY ATTN AMSRL ST DR FRASIER 2800 POWDER MILL RD ADELPHI MD 20783-1197
1	ARMY RESEARCH LABORATORY ATTN AMSRL SL DR WADE WSMR NM 88002-5513
1	ARMY RESEARCH LABORATORY ATTN AMSRL SL E MR MARES WSMR NM 88002-5513
1	ARMY TRADOC ANL CTR ATTN ATRC W MR KEINTZ WSMR NM 88002-5502
1	ARMY TRNG & DOCTRINE CMND ATTN ATCD B FT MONROE VA 23651
	<u>ABERDEEN PROVING GROUND</u>
1	CDR USATECOM ATTN: AMSTE-TA
2	CDR USAMSA ATTN: AMXSY-ST AMXSY-D
4	DIR USARL ATTN: AMSRL-SL, J WADE (433) AMSRL-SL-I, M STARKS (433) AMSRL-SL-C, W HUGHES (E3331) AMSRL-SL-B, P DEITZ (328)
1	CDR CBDCOM ATTN: TECHNICAL LIBRARY BLDG E3330
1	DIR CBIAC BLDG E3330, RM 150

<u>NO. OF</u> <u>COPIES</u>	<u>ORGANIZATION</u>	<u>NO. OF</u> <u>COPIES</u>	<u>ORGANIZATION</u>
1	HQDA DUSA OR ROOM 2E660 102 ARMY PENTAGON WASHINGTON DC 20310-0102	1	DIRECTOR USARL ATTN AMSRL OP TL WATERTOWN MA 02172-0001
1	DEP CHIEF OF STAFF OPERATIONS AND PLANS ATTN DAMO SW ROOM 3C630 400 ARMY PENTAGON WASHINGTON DC 20310-0400		DIRECTOR USARL ATTN AMSRL SL E G MARES AMSRL SL EA R SHELBURNE AMSRL SL EG J PALOMO AMSRL SL EM R FLORES AMSRL SL EP D ALVAREZ AMSRL SL ES T ATHERTON AMSRL SL EV DR K MORRISON AMSRL SL CA R SUTHERLAND WHITE SANDS MISSILE RANGE NM 88002-5513
1	COMMANDER US ARMY MISSILE COMMAND ATTN AMSTA CG REDSTONE ARSENAL AL 35898-5000		
1	DIRECTOR US ARMY BALLISTIC MIS DEFNS SYS CMND ATTN ADVNCD TECHLGY CTR PO BOX 1500 HUNTSVILLE AL 35807-3801	1	DIRECTOR USARL ATTN AMSRL EP M V GELNOVATCH FT MONMOUTH NJ 07703-5601
2	COMMANDER USA STRTGC DEFNS CMND ATTN CSSD SL C CSSD SL S HUNTSVILLE AL 35807-3801	1	DIRECTOR USARL ATTN AMSRL EP EF DR M. DUTTA FT MONMOUTH NJ 07703-5601
1	COMMANDER CECOM R&D TECH LIB ATTN ASQNC ELC IS L R FORT MONMOUTH NJ 07703-5000	1	DIRECTOR USARL ATTN AMSRL SS V DEMONTE ADELPHI MD 20783-1197
1	COMMANDER US ARMY RESEARCH OFFICE ATTN TECH LIB PO BOX 12211 RESEARCH TRIANGLE PARK NC 27709-2211	1	DIRECTOR USARL ATTN AMSRL SS IC DR P EMMERMAN ADELPHI MD 20783-1197
1	COMMANDER USA LOGISTICS MGMT CTR ATTN DEFNS LGSTCS STUDIES FORT LEE VA 23801	1	DIRECTOR USARL ATTN AMSRL SS IC R WINKLER ADELPHI MD 20783-1197
1	COMMANDER US ARMY NGIC ATTN AMXST MC 3 220 SEVENTH ST NE CHARLOTTESVILLE VA 22901-5396	1	DIRECTOR USARL ATTN AMSRL WT NH DR H E BRANDT ADELPHI MD 20783-1197

<u>NO. OF COPIES</u>	<u>ORGANIZATION</u>
1	COMMANDANT USA CMND AND GENL STAFF FORT LEAVENWORTH KS 66027
1	DIRECTOR INSTITUTE OF DEFNS ANLYS ATTN LIBRARY 1801 BEAUREGARD ST ALEXANDRIA VA 22311
	<u>ABERDEEN PROVING GROUND</u>
1	DIR, USAERDEC ATTN SCBRD RT
1	CDR, USACBDA ATTN AMSCB CII
1	CDR, USAATC ATTN STECS
77	DIR, USARL ATTN AMSRL SL J SMITH AMSRL SL BA J MORRISSEY J HANES R KUNKEL L ROACH AMSRL SL BG A YOUNG AMSRL SL BS D BELY T KLOPCIC AMSRL SL BV R SANDMEYER W MERMAGEN JR AMSRL SL C W J HUGHES J SEIGH MAJ GILMAN AMSRL SL CM D FARENWALD B RUTH L DAVIS L DELICIO R JOLLIFFE D SLOOP R TYTUS R ZUM BRUNNEN E FIORAVANTE M MAR DR ŠOLN (30 CPS)

<u>NO. OF COPIES</u>	<u>ORGANIZATION</u>
	AMSRL SL CO D BAYLOR R PROCHAZKA
	AMSRL SL CS J BEILFUSS T FLORY B SMITH M SMITH J FRANZ T MAK J NEALON R PARSONS M KAUFMAN D MANYAK R POLIMADEI M BUMBAUGH J CAPOBIANCO D DAVIS
	AMSRL SL I R REITZ D BASSETT A YOUNG M VOGEL E PANUSKA D HASKELL J FEENEY R ZIGLER

USER EVALUATION SHEET/CHANGE OF ADDRESS

This Laboratory undertakes a continuing effort to improve the quality of the reports it publishes. Your comments/answers to the items/questions below will aid us in our efforts.

- 1. ARL Report Number ARL-TR-979 Date of Report March 1996
- 2. Date Report Received _____
- 3. Does this report satisfy a need? (Comment on purpose, related project, or other area of interest for which the report will be used.) _____

- 4. Specifically, how is the report being used? (Information source, design data, procedure, source of ideas, etc.) _____

- 5. Has the information in this report led to any quantitative savings as far as man-hours or dollars saved, operating costs avoided, or efficiencies achieved, etc? If so, please elaborate. _____

- 6. General Comments. What do you think should be changed to improve future reports? (Indicate changes to organization, technical content, format, etc.) _____

**CURRENT
ADDRESS**

Organization

Name

Street or P.O. Box No.

City, State, Zip Code

7. If indicating a Change of Address or Address Correction, please provide the Current or Correct address above and the Old or Incorrect address below.

**OLD
ADDRESS**

Organization

Name

Street or P.O. Box No.

City, State, Zip Code

(Remove this sheet, fold as indicated, tape closed, and mail.)
(DO NOT STAPLE)

DEPARTMENT OF THE ARMY

OFFICIAL BUSINESS

BUSINESS REPLY MAIL
FIRST CLASS PERMIT NO 0001,APG,MD

POSTAGE WILL BE PAID BY ADDRESSEE

DIRECTOR
U.S. ARMY RESEARCH LABORATORY
ATTN: AMSRL-SL-CM
ABERDEEN PROVING GROUND, MD 21010-5423



NO POSTAGE
NECESSARY
IF MAILED
IN THE
UNITED STATES

