

# Nondestructive Inspection and Evaluation of Composite-Material Flywheels—Volume 2

K. L. Reifsnider

D. M. Boyd

S. V. Kulkarni

DEPARTMENT OF DEFENSE  
PLASTICS TECHNICAL EVALUATION CENTER  
AERABCOM, DOVER, N. J. 07804

DISTRIBUTION STATEMENT A  
Approved for public release;  
Distribution Unlimited

February 24, 1982

Lawrence  
Livermore  
National  
Laboratory

19960322 132

DTIC QUALITY INSPECTED 1

5/15

## DISCLAIMER

This document was prepared as an account of work sponsored by an agency of the United States Government. Neither the United States Government nor the University of California nor any of their employees, makes any warranty, express or implied, or assumes any legal liability or responsibility for the accuracy, completeness, or usefulness of any information, apparatus, product, or process disclosed, or represents that its use would not infringe privately owned rights. Reference herein to any specific commercial products, process, or service by trade name, trademark, manufacturer, or otherwise, does not necessarily constitute or imply its endorsement, recommendation, or favoring by the United States Government or the University of California. The views and opinions of authors expressed herein do not necessarily state or reflect those of the United States Government thereof, and shall not be used for advertising or product endorsement purposes.

# **Nondestructive Inspection and Evaluation of Composite-Material Flywheels—Volume 2**

**K. L. Reifsnider\***

**D. M. Boyd**

**S. V. Kulkarni**

**Manuscript date: February 24, 1982**

---

\*On sabbatical leave from Virginia Polytechnic Institute and State University, Blacksburg, VA.

**LAWRENCE LIVERMORE LABORATORY**  
University of California • Livermore, California • 94550 

Available from: National Technical Information Service • U.S. Department of Commerce  
5285 Port Royal Road • Springfield, VA 22161 • \$6.00 per copy • (Microfiche \$3.50)

## Foreword

Work reported herein has been performed for the Composite Flywheel Rotor and Containment Technology Development Task of the DOE-sponsored Mechanical Energy Storage Technology (MEST) project. This effort is directed at LLNL by Satish V. Kulkarni.

The report consists of two parts:

1. *Nondestructive Inspection and Evaluation of Composite-Material Flywheels—Volume 1*, D. M. Boyd, B. W. Maxfield, S. V. Kulkarni, and A. J. Schwarber.
2. *Nondestructive Inspection and Evaluation of Composite-Material Flywheels—Volume 2*, K. L. Reifsnider, D. M. Boyd, and S. V. Kulkarni.

Volume 1 describes the nondestructive investigation (NDI) of various prototype composite flywheels before the proof-of-concept burst tests were conducted. Volume 2 presents a discussion of various NDI techniques and their applicability to composite materials and flywheels. Results of nondestructive evaluation (NDE) to assess damage accumulation in composite-material flywheels which were subjected to loading cycle(s) at rotational speeds below the expected burst speeds are also given in Volume 2.

The authors would like to acknowledge the contributions of Ellen Placas and Gene Ford of the Nondestructive Evaluation section of LLNL for conducting the radiographic tests.

## Contents

Foreword .....	ii
Abstract .....	1
Introduction .....	1
Nondestructive-Inspection Methods for Fibrous Composite Materials .....	3
Ultrasonic Techniques .....	3
Acoustic Emission .....	5
Monitoring Stiffness Change .....	6
Vibrothermography .....	7
X-ray Radiography .....	7
Optical Techniques .....	8
Nondestructive Evaluation of Flywheels .....	9
Purpose and Function .....	9
Radiographic Nondestructive Evaluation .....	10
Hercules Flywheel .....	10
Brobeck Flywheel .....	10
Rocketdyne Flywheel .....	11
Garrett AiResearch Flywheel .....	12
Molded Sheet-Molding-Compound Disk/Filament-Wound Rim Flywheel .....	13
AVCO Bidirectionally Woven Disk .....	16
Ultrasonic Nondestructive Evaluation .....	16
Laminated Composite Panels .....	17
Post-Spin Test Nondestructive Evaluation of Flywheels .....	19
LLNL Constant-Thickness Laminated Disks .....	19
Garrett Near-Term Electric-Vehicle Flywheel .....	21
Summary .....	22
References .....	25

# Nondestructive Inspection and Evaluation of Composite-Material Flywheels – Volume 2

## Abstract

It has been demonstrated that flywheels made from composite materials are capable of storing energy with a significantly higher energy density than those made from conventional metals. Since composite materials are also very durable and inherently safer for such applications, it would appear that they will play a major role in flywheel energy-storage systems. This report addresses the question of how flywheels made from composite materials can be inspected with nondestructive test methods to establish their initial quality and their subsequent integrity during service. A variety of methods is discussed in the context of special requirements for the examination of composite flywheel structures and the results of several example nondestructive evaluations before and after spin testing are presented. Recommendations for general nondestructive testing and evaluation of composite-material flywheels are made (NATHAN).

## Introduction

Recently under the leadership of LLNL, a group of industries, Universities, and other Laboratories have demonstrated that flywheels made from composite materials are capable of storing energy with a significantly higher energy density than those made from conventional metals. Composite flywheels are also inherently safer than metal wheels for applications in vehicles and other devices since the failure of such wheels does not generally produce large pieces of massive material that become dangerous projectiles. Failure of the composite wheels usually produces highly fragmented particles that can be easily contained.

The success of composite materials for flywheel applications has brought with it several challenges. One such challenge is the need to establish manufacturing quality and durability by nondestructive evaluation. Several factors make this a formidable challenge. The flywheel itself is a high-speed rotating structure that can fail in various ways, caused by various events. The failure modes and initiation events are difficult to anticipate and may be related to dynamic (especially stability) considerations. Also, the composite materials themselves require special attention. Damage in composite materials is generally very complex and an understanding of precisely how damage is related to the strength, stiffness, and useful life of these materials has not been well developed. In the remainder of this section we

will discuss information and concepts that relate to the behavior of composite materials used in flywheels. Various nondestructive inspection (NDI) techniques, their applicability to composite materials, and nondestructive evaluation (NDE) of flywheels will be discussed subsequently.

The materials usually used in composite flywheels are filamentary, generally referred to as advanced composites. They consist of fibers made from graphite, glass, or organic material (aramids) embedded in a matrix material such as epoxy. Ribbons of amorphous metal have also been used for the rim of flywheels. Most of our discussion will deal with fibrous composite materials.

Several properties and characteristics of composite materials require special attention if we are to properly apply NDE techniques to them and to properly interpret the results of such applications. If the fibers in the composite are aligned either in individual plies of a laminate or in the entire cross section of the material or component, the composite will be anisotropic. Hence, the results of any test that depends on direction will generally be different when the test is applied in different directions relative to the fiber orientations. For unidirectional fibrous composites, four (independent tensor) quantities are needed to specify the in-plane stiffness of a planar array of such a material. For example, if one wishes to apply an NDE technique that involves wave propagation, the

wave speeds will depend on these four stiffness components and will be highly directionally dependent.<sup>1</sup> The direction of wave travel, direction of energy travel, wave modes, and mode conversions are all highly sensitive to this anisotropy. These sensitivities must be accounted for in the interpretation of results as well as during the design of NDE tests based on wave propagation. Such tests include ultrasonic attenuation, acoustic emission, and ultrasonic C-scan methods. The anisotropy also affects stress distributions. Consequently, optical methods that depend on strain distributions must be interpreted in light of the anisotropic properties. Conductivity is also anisotropic for such materials. Hence, thermal or electrical NDE devices will operate with directional dependence.

Strength will also be anisotropic since the stress at failure in the fiber direction will not be the same as the strength measured perpendicular to that direction. Because of this, damage can develop differently in different directions, requiring additional NDE information for its determination. Such anisotropy is not necessarily an obstacle to successful NDE. It is rather an opportunity for exploitation. For example, changes in each of the four elastic moduli can be related independently to different types of damage, thus providing a nondestructive method of identifying specific types or combinations of defects that are peculiar to specific combinations of material and load history. Similar principles can be applied to other NDE schemes.

A second major characteristic of composite materials that affects NDE efforts is inhomogeneity, i.e., the presence of distinct material phases. From the standpoint of nondestructive evaluation, this characteristic is rarely an opportunity for exploitation. It is more often an obstacle. The most obvious example of this is found in ultrasonic wave propagation (attenuation, pulse echo, and acoustic emission). Such waves are so effectively dispersed by the internal inhomogeneous microstructure of composite materials that it is difficult in some cases to get the waves to travel through the material or component that is under test. Such a problem may preclude these techniques from use. More often such difficulties can be overcome with an adjustment of technique. For the case of acoustic emission, however, the interpretation of emission data, difficult under any circumstance, is made more difficult by the multimode transmissions, reflections, and resonances in a composite material.

Another basic consequence of the inhomogeneity of composite materials is the widely dispersed and very complex nature of the damage that occurs during load application. The damage may consist of: matrix cracking, delamination, debonding, and fiber breakage that occurs in a variety of combinations and in a large number of locations. Consequently, NDE methods that concentrate on, or are directed towards the detection and characterization of a single crack (or flaw), are not likely to be very useful for composite materials. In fact, NDE techniques that are able to detect arrays of defects, and especially those providing information about the collective effect of the defects that occur, are essential if NDE of composite materials is to provide a means for assessing the integrity of these materials in a way that can be related to strength, stiffness, and useful life. Inhomogeneity also means that there are many boundaries that are potential trouble spots so that techniques sensitive to internal surfaces are necessary. This is especially true since many advanced composite materials are also laminated together to make thicker sections. These lamination boundaries are also potential locations for defects. Another important consequence of this type of inhomogeneity is a proclivity for manufacturing defects. In a sense, there are so many opportunities for things to go wrong during the manufacturing of composite materials that such defects are quite common. While such things as incompletely consolidated material may be relatively easy to detect, such things as poorly bonded interfaces are frequently extremely difficult to detect. Hence, the quality-control problem may be more severe for composite materials, in comparison to common metals.

A third and last characteristic that is sufficiently important to be noted is behavioral. We have mentioned that defects or damage in fibrous composite materials may consist of matrix cracking, delamination, fiber fracture, and debonding. However, we must be careful not to be simplistic about our interpretation of what damage is. For example, let us consider the strength under uniaxial loading of a coupon of laminated composite material that has a through hole in the center of the width, with a diameter-to-width ratio of 0.25. Let us assume that the strength measured under quasistatic loading is 70% of the net section strength. Then let us further assume that a cyclic (fatigue) load with an amplitude equal to 60% of that break strength is applied for 105 cycles. Some damage will develop around the center hole, i.e.,

depending on the laminate type, matrix cracking, delamination, and some fiber fracture will generally occur in regions of high stress. Now suppose we load the fatigue-damaged specimen to failure in a quasistatic test. We will find that the strength has been *increased* by the fatigue damage around the hole. In fact, we may find that the stress concentration around the hole has been reduced to nearly zero in the sense that the specimen has essentially the net section strength of the two ligaments on either side of the hole, a common result for fiber-dominated laminates. In a sense, the damage in this case has relieved the stress concentration near the hole, which is a beneficial effect. *Hence, NDE schemes that simply identify the*

*presence of damage cannot be used directly to imply the strength, stiffness, or useful life of a composite component.* The NDE schemes we must develop and use must be closely and directly related to the physics and mechanics, which control the response of the composite materials being examined. We must in any case avoid simplistic interpretations of NDE information.

Having discussed how the properties and characteristics of composite materials affect the manner in which NDE is employed to test composite flywheels, we now focus our attention on the capabilities and limitations of various NDE methods.

## **Nondestructive-Inspection Methods for Fibrous Composite Materials**

An excellent review of this topic has recently been made by Henneke and Duke.<sup>2</sup> The detailed findings of their report will not be reproduced here. Instead, a brief interpretation of the report and other available information, in terms of our present purpose, will be given for several major NDE techniques in preparation for the next section, which will concentrate on flywheels rather than on NDE techniques.

### **Ultrasonic Techniques**

Perhaps the most widely used NDE technique for the materials that are of present interest is ultrasonic sound transmission and reflection. In general, ultrasonic methods can be used to detect voids, delaminations, and matrix cracking (to various degrees), but it is not always possible to distinguish between such damage modes with ultrasonic information alone.<sup>3</sup>

Sound waves propagate with speeds that are proportional to the square root of various combinations of the (tensor) elastic constants for the propagating material. Hence it is possible to determine the elastic stiffnesses by measuring the propagation speeds of various waves in a composite material.<sup>4</sup> It has also been shown that certain types of damage, such as matrix cracking, produces changes in the elastic constants that are measured by wave-propagation techniques.<sup>5</sup> However, a quantitative association has not been made and correlations with other types of damage

have not been established. Sound-wave speed measurement is a feasible technique for composite materials and does have the advantage of being inherently sensitive to all aspects of the anisotropy that may be present in a given material and to the effects of that anisotropy on damage development.

Another ultrasonic scheme is commonly called the pulse-echo arrangement. In this scheme an ultrasonic beam is sent out in bursts from a transducer to produce a train of pulses that are separated by adjustable periods of time. The pulses travel through the test medium until a reflection or echo is produced by a discontinuity. Such a scheme is inherently suited for the detection of a discrete flaw or flawed region. When a great many reflections are produced by a distribution of flaws, interpretation is not possible. Thus for composite materials, defects such as delaminations are most easily detected with this scheme.

There are many variations to the basic pulse-echo ultrasonic concept. The most popular is the so-called C-scan arrangement. This method usually incorporates scanning capabilities that produce a plain view of the pattern of echos that return from (or traverse) a specimen. The choice of what set of echos to use to produce such a pattern, and the levels at which gates are set to discriminate echo intensities to detect the presence of flaws as they influence the amplitudes of the chosen echos, forms the basis for this scheme. For example, one may choose to consider the reflected wave from the back surface of a plate or disk

specimen and set the gate so that a defect is indicated when 10% of the amplitude of that reflection is lost. Such a scheme can detect widely distributed and complex damage, since the dispersion that is caused by any damage can also be detected by a reduction in the amplitude of a given echo, as described above. C-scan techniques seem to have their greatest sensitivity to delaminations or other internal surfaces.<sup>2,6,7</sup> They are less sensitive to widely distributed microcracking, especially if the cracks lie in the plane that contains the vector direction of propagation of the wave being used.

If the presence of damage is established by a C scan, it may be possible to locate the position of the defect or defects in the thickness direction by use of a so-called B scan. This scan is a simple pulse-echo scheme whereby the time of travel for the echo from a flawed region is used to determine the position of the defect. This assumes, however, that some reflection from the defect can be obtained, which is not always possible. Delaminations usually do produce such an echo but widely dispersed voids may not.

The amplitude of transmitted or reflected ultrasound can be used directly as the basis of an NDE scheme by measuring attenuation, the factor that characterizes the incremental loss in amplitude, as an ultrasonic wave pulse traverses a flawed material region. While C-scan methods, which may depend on only a few gate settings, have some difficulty discriminating different types or different severities of damage, ultrasonic attenuation measurements have an advantage of producing a quantitative parameter value that may contain this type of information. Because of this, ultrasonic attenuation has excellent sensitivity to matrix cracks, voids, and other types of widely dispersed damage.<sup>8-12</sup> However, the sensitivity to matrix cracking has been more completely verified than the sensitivity to voids. Attenuation of ultrasound can occur by dispersion from microcracks, voids, and internal material discontinuities, but it can also occur by diffraction and by microelastic (energy) dissipation. Hence, not only voids, but such things as resin-rich regions can be located. However, dispersion, diffraction, and (microelastic) dissipation phenomena are wavelength and frequency dependent so that the choice of ultrasonic frequencies for testing becomes an important consideration for this method.

Although there is no axiomatic philosophy that can be used to directly interpret ultrasonic attenuation measurements in terms of materials

response, some very useful correlations have been made by a number of investigators. There is considerable evidence that ultrasonic attenuation can be related to the residual strength of fibrous composites, especially those with resin matrix materials.<sup>4,13-15</sup> Although the best correlations are with matrix-dominated strength properties such as short-beam shear strength, other strength properties have shown similar correlations. A related correlation appears to exist between moisture-induced degradation and ultrasonic attenuation. Not only have correlations between attenuation and moisture-degraded residual strength been identified,<sup>16</sup> but a correlation between attenuation and moisture absorption itself has been established in some cases.<sup>17-19</sup> Most of this work has been done on graphite/epoxy and glass/epoxy. Ultrasonic attenuation is especially useful for the detection of damage thresholds, damage initiation, and relatively low levels of fairly uniformly distributed damage. These situations tend to be the most difficult to deal with when using either of the NDE techniques. For highly localized and severe damage, multiple reflections will not be possible since the ultrasonic pulse will be so severely disrupted that nothing remains to carry the information back to the detector.

There are a large number of variations of ultrasonic techniques. Specific use can be made, for example, of various aspects of the dispersion or interferences created by a given material under a given excitation. In some cases, for example, it appears that one can use the diffraction of ultrasound from regularly spaced cracks to establish internal matrix crack densities in laminated composite panels.<sup>9-11</sup> Angular incidence can be used to establish fiber orientations in laminated and chopped-fiber composite plates.<sup>20</sup> Various choices of frequencies, detectors, and data processing can be combined for tasks that range from determining the material integrity following manufacture to detecting fatigue damage as early as 1% of the total fatigue life.<sup>21</sup> The success of a given technique depends for the most part on the availability of a significant quantitative data base that relates the NDE indications to the response in question.

The equipment required to conduct ultrasonic NDE is relatively modest, depending on the size of the parts or components to be examined, the sophistication of the technique needed to make the determinations required, and the degree of automation of the data gathering and data processing needed. It is also possible to build up an ultrasonic system incrementally since the various

components of the system are usually modular, allowing one to add capability and sophistication as needed. Although there are no figures to support such an observation, it is likely that ultrasonic methods are the most widely used of all NDE schemes for composite materials.

## Acoustic Emission

Another general NDE method that has received a lot of attention, especially for composite materials, is the use of acoustic emission. A recent review article by Williams and Lee<sup>22</sup> provides an extensive source of information about the use of acoustic emission (AE) to monitor the response of composite materials. Since damage in such materials is very complex, it is no surprise that damage development is very noisy. However, it should be emphasized that AE must be recorded during loading (service loading, proof testing, etc.) so that the energy released by the *damage events* is being detected, not the damage itself. Hence, the type of information obtained is basically different from that obtained from ultrasonic, radiographic, or other NDE methods. It is conceivable that pre-existing damage could be made to emit sounds caused by such events as internal surface rubbing, load redistributions, or other phenomena, but generally materials obey the so-called Kaiser effect whereby no emission occurs upon reloading a specimen or component until the maximum load level from a previous loading is exceeded. There is still discussion of this generalization in the literature. Some investigators claim the Kaiser effect holds for their experiments,<sup>23-25</sup> while others claim that it is violated for their case.<sup>26</sup>

Acoustic emission appears to be a fairly reliable indicator of internal damage development and numerous investigators have reported that it is possible to discriminate between the emissions caused by different kinds of damage events under carefully controlled situations. Some claim that fiber fracture, matrix fracture, and debonding, for example, have different characteristic AE signatures.<sup>23</sup> Others claim that massive delaminations can be identified by very large amplitude emissions.<sup>27</sup> In graphite/epoxy it appears that, in general, the plastic flow of the matrix gives rise to high-frequency emissions, while fiber failures and debonding are sources of low-frequency emissions. Spectral-energy distributions are widely used as a means of discriminating between different modes of damage and different material effects on AE.<sup>28-31</sup> However, it should be noted that

these methods of discrimination are generally empirical and are not always quantitative in the strict sense.

The correlation of AE with mechanical properties of various types has been widely reported. A number of investigators have been able to identify various aspects of AE that correlate with the ultimate tensile strength of composite materials.<sup>32-34</sup> Correlations between stiffness change and AE have also been reported.<sup>30,35</sup> The relationship of AE to useful life is less often reported. Chang et al. found that AE count rate was a good indicator of damage growth rate,<sup>27</sup> but correlations with useful life are difficult to find.

It is possible to extract spatial information from AE data by using various versions of triangulation based on the time of travel to several different transducers. For large structures such a scheme is especially useful for locating trouble spots that may require more careful scrutiny. In fact, more than any other common NDE technique, AE is widely used to monitor large structures from bridges to pressure vessels. For example, filament-wound Kevlar/epoxy pressure vessels with metallic liners have been examined by Hamstad et al.<sup>36-42</sup> They found it was not possible to predict the burst pressure of the pressure vessels from the AE patterns obtained during proof testing. However, they also found that manufacturing errors such as high humidity during winding, low or high matrix content, cure-temperature discrepancies, incorrect ratios of matrix content, fiber damage, and incorrect winding tension did produce significant and identifiable changes in the proof-testing AE signatures. It would appear from these studies and a number of other investigations that AE used with a proof-testing scheme is a viable quality-control method in some cases.

In general, as noted in Ref. 2, AE techniques as they exist at present suffer from a lack of quantitative understanding, interpretation, reproducibility, and use. Such factors as the transducer-specimen couplant, transducer variability, method of transducer attachment, type of transducer, type of signal (data) acquisition, type of data analysis, positioning of transducers, geometry of the specimen, calibration of equipment, and other items may significantly affect the AE results. In general, reliable and reproducible results can only be obtained when these factors are carefully controlled. There is much more art than science in the AE literature, but the technique is so widely used that the experience of others can often be used to guide the direction of a new application.

## Monitoring Stiffness Change

Another general NDE method of fairly recent extraction is the use of stiffness change to monitor damage in composite materials. A recent review article discusses this method.<sup>43</sup> There are two basic approaches associated with this method. For widely distributed damage such as matrix cracking, fiber-matrix debonding, and other dispersed damage types, the stiffness approach consists of measuring one or more of the independent tensor stiffness components of the composite specimen (assuming it is anisotropic) and relating the changes in these stiffness components to the internal damage using relationships that appear in the literature.<sup>44-46</sup> Matrix cracking, for example, would be expected to cause changes in the matrix-dominated stiffness components, such as the engineering Young's modulus in the direction perpendicular to the fibers in a given ply, or the in-plane shear stiffness, while the fiber-direction stiffness should be affected to a much lesser degree. Such changes and many others have been observed. Delamination of a laminate is most quickly detected by a change in laminate Poisson's ratio and fiber fractures will cause changes in the fiber-direction stiffness. Use of stiffness changes to monitor damage has several advantages over other common NDE methods. Since there are generally several independent stiffness components available for characterization, it is frequently possible to discriminate between different types of (internal) damage by identifying different combinations of stiffness component changes. Also, since stiffness is a global quantity, the critical (and most difficult) step in the interpretation of NDE data is automatically performed by the measurement itself, i.e., the step from detecting some microdamage event to determining how that event affects macrobehavior. The variations in stiffness have a direct macroscopic interpretation since stiffness is used directly to determine stress distributions under a given set of applied loads. A third advantage is that stiffness is an established characteristic, routinely measured with considerable precision and (generally) excellent reproducibility. It is a universal quantity that has an unambiguous interpretation. However, stiffness-measurement techniques have their disadvantages too. It is not always easy to measure the stiffness changes caused by microdamage in composite materials. The changes may be only on the order of 5% in some cases and certain of the tensor components are

difficult to measure at all. However, the use of stiffness change as an NDE method is growing rapidly.

The second basic stiffness approach differs from the first primarily from the standpoint of interpretation and the type of damage involved. If the damage to be detected is highly localized, such as the growth of delamination in a laminate, compliance measurements (which are widely used in fracture mechanics) are appropriate. In fact, elements of fracture mechanics in general apply in some cases where the damage propagates in a self-similar way through fairly uniform material. Compliance used in this way to characterize effective flaw sizes for localized damage and to relate to strain-energy release rates, is extensively discussed in the literature.<sup>47,48</sup> Further discussion will not be given here. However, it should be mentioned that several attempts to apply these concepts to composite-material delamination growth have been quite successful.<sup>49,50</sup>

Relationships between stiffness or stiffness changes and the residual strength and useful life of composite materials have been reported by several investigators. Both notched and unnotched specimens have shown a correlation between elastic stiffness changes and residual strength.<sup>37,44</sup> However, the most extensive correlations have been conducted during fatigue loading. This is partly because the (load-direction) stiffness of many fibrous composite laminates degrades noticeably early in their fatigue life.<sup>51-56</sup> In addition to the interpretation schemes mentioned above, relationships between stiffness change and useful life have been developed.<sup>56</sup> One of the most popular such relationships is the so-called secant modulus criterion. This criterion states that fatigue failure will not occur until the secant modulus of a specimen under fatigue loading has been reduced to the level (or below) corresponding to the minimum secant modulus in a quasistatic tension test. This criterion has been found to apply reasonably well to a number of glass/epoxy and boron/epoxy laminates.<sup>44,56</sup> Relationships between fatigue damage growth in off-axis plies and changes in the in-plane shear stiffness have also been established.<sup>49</sup>

Like all NDE methods, especially when used for composite materials, stiffness change is still in a stage of development. However, our ability to interpret the data and the familiar relatively well established methods of measurement make this technique an important addition to the field of NDE capabilities.

Another closely related NDE scheme involves the use of mechanical damping measurements to determine the material damping. The measurement represents the proportion of input energy that is dissipated by various internal defects during cyclic excitation. Methods of measuring such damping are well established but not well standardized.<sup>57-62</sup> Vibrating-beam and complex (or dynamic) modulus measurement techniques are the most commonly used. Both of these schemes are very sensitive to damage in composite materials and have produced data that have been shown to be well correlated with damage development in those cases examined.<sup>62-64</sup> The problems associated with this type of NDE approach result from a lack of standardization and the difficulties encountered in the determination of material damping. Vibrating-beam methods measure system damping so that careful interpretation of the data and careful control of the test are required. Also, dynamic modulus determination is dependent on the equipment used, especially in the sense that the rate of loading may be important to the constitutive behavior of the material being tested. Other testing parameters may interact with the materials response in complex ways. Perhaps the most uncertain aspect of damping as an NDE method is the interpretation of the results. There are a large number of mechanisms, especially for composite materials, that can dissipate energy. Damping can be caused by viscoelastic response, plastic deformation, a myriad of non-conservative atomic and molecular motions, incompatible constituent phase motions, and surface-surface interactions.<sup>43</sup> It is not clear at present how these different dissipative mechanisms can be identified from damping measurements of the common type described above. The relationship of these mechanisms to the strength, stiffness, and useful life of composite materials has not been established. Nevertheless, damping is a very sensitive detector of the presence of damage and therefore can be used for empirical correlations or to indicate when other techniques (which can identify more specific damage characteristics) should be employed.

### Vibrothermography

Before leaving the concept of damping and energy dissipation, an NDE technique based on that concept should be noted. Over the past 5 years an NDE method called vibrothermography has been developed.<sup>43</sup> It employs mechanical ex-

citation of various types, carefully chosen to excite various dynamic responses from specific types of internal defects, which then lead to hysteretic energy dissipation. This dissipation produces thermal patterns on the surface of the specimen that can be observed with a video-thermographic device. A simple example of this technique might be the observation of a specimen during fatigue testing. As local damage develops, the dissipative heat pattern will develop irregularities that indicate local defect development. If the specimen is constructed from a composite material, the complex development of damage will cause a more general nonuniformity in the heat pattern that represents the collective effect of the damage. It has been shown that in many cases these heat patterns are directly related to stress distributions.<sup>65</sup> Hence, vibrothermography offers a time-resolved optical-field technique that is directly sensitive to the distribution and severity of damage in composite materials. Since the scheme is a noncontact method, it is especially useful for monitoring components during service loading. The technique is especially sensitive to internal defects having surfaces that may be close to one another or in contact under relatively low contact stresses. By choosing a proper input excitation frequency, such defects can usually be made to dissipate energy very effectively, making them quite easy to identify.

### X-ray Radiography

One of the classical NDE techniques widely used for composite materials is x-ray radiography. This technique depends on the (electron) density of the material through which the x-ray beam passes for selective absorption and defines the internal details of interest. However, composite materials such as graphite/epoxy, glass/epoxy, and Kevlar/epoxy do not have high electron density atoms so they are generally very transparent to x rays. Hence, small variations in internal density due to defects are difficult to resolve. Defects such as fiber-matrix debonding, low-density inclusions, tightly closed cracks, or delaminations with their plane perpendicular to the direction of incidence of the x-ray beam are especially difficult to identify. Large porosity, dense inclusions, fiber spacing and alignment, fiber fractures, and cracks (or delaminations) that have a defect plane parallel to the direction of the input beam are more easily detected. Low-energy x rays with relatively low excitation voltages (generally less than 20 kV) are

best suited for composite-material examination if the matrix is polymeric. A majority of the radiographic work in the literature was done with the aid of an opaque penetrant, such as tetrabromoethane (TBE) or diiodobutane (DIB), which is applied to the surface of the specimens and flows into defects having a surface opening. The opaque material is a very effective method for making defects that contain it more visible when subsequent radiographs are made. Such a scheme, for example, can be used to provide excellent definition of matrix cracks and (otherwise unresolved) delaminations near edges, especially in the neighborhood of stress concentrations.<sup>6,66,67</sup> Some investigators have found that TBE-enhanced radiography is able to resolve subcracks much better near a notch or large crack than ultrasonic C-scan methods.<sup>68</sup> However, the penetrant method has its disadvantages. TBE and DIB are toxic and difficult to handle. TBE has the added problem of being an effective solvent for polymeric matrix materials, i.e., it can cause damage by chemical attack. Also, if defects do not reach the surface, a penetrant cannot reach them. (Other opaque penetrants such as gold chloride and zinc iodide are not health threatening and, depending on the carrier solution selected, are not as likely to cause chemical degradation of the epoxy material.) Impact damage, for example, may not be easily found or resolved using the opaque penetrant-assisted x-ray radiography. In many cases careful choice of radiographic techniques will produce excellent information without penetrants, as will be demonstrated in a later section. In general, radiography is a very successful NDE method for composite materials if properly applied. Of course, if x-ray equipment must be purchased, the cost of such apparatus is a clear disadvantage, commonly running from a range of a hundred to several hundred thousand dollars. (This is also a disadvantage for the thermographic equipment mentioned earlier.)

## Optical Techniques

Optical NDE techniques are another class of test methods that can be used for composite materials. One of the most popular methods is the use of holographic interferometry. This method requires stressing the component by thermal or mechanical loading. Holography can be used to measure surface displacements to determine strains or to identify defects by nonuniformities in deformation fields.<sup>69-71</sup> The sensitivity of a given

holographic arrangement is dependent not only on the type of holographic equipment employed, but also on the specific type of loading applied to the component being tested. Under suitable loading conditions, it is possible to identify broken fibers, delaminations, and fiber overlaps in glass/epoxy.<sup>72</sup> The equipment required for holography is fairly sophisticated and its application generally requires a highly trained and experienced individual. However, the sensitivity of holography to perturbations in surface deformation patterns is unsurpassed by any other NDE technique.

Other optical methods may also be useful, especially for recovering field strain data. Surface moiré methods are returning to use for composite materials largely due to a series of new application-oriented developments in recent years.<sup>73</sup> Moiré gratings with 20,000 lines/in. can be affixed to the surface of a composite material to obtain excellent sensitivities not possible even a few years ago. Diffraction gratings with 60,000 lines/in. are now available and can be bonded to the surface of specimens or components to be studied.

For composite materials having photoelastic matrix materials, photoelasticity can be used as a method for determining stresses, not only in the stressed composite, but also to determine residual stresses in the constituent materials for the unloaded case.<sup>74-76</sup> Of course, photoelastic materials can be bonded to the surface of a composite component to resolve the surface deformations as one would for any other material.

Aside from a fairly high degree of sophistication involved in most optical NDE schemes, as mentioned earlier the application of these methods is also complicated by the fact that deformation patterns on the surface of composite materials are sometimes microscopically nonuniform. The nonuniformity is a result of the normal inhomogeneity of the material and the abnormalities in the inhomogeneity inadvertently created by the manufacturing processes. These nonuniformities make the recording and interpretation of data difficult, especially when global behavior is to be associated with the microdeformation patterns. Generally speaking, the optical techniques are preferred for locating irregularities in deformation patterns and for the determination of surface strains over relatively limited areas (on the order of  $100 \times 100$  mm).

This brief review of NDE techniques is not intended to be a complete description or discussion of all of the methods that one can use to evaluate the integrity of composite materials. While

the methods discussed above are the major ones, many variations of these methods already exist and the development of other variations (and techniques) is limited only by the diversity of the technical community and fiscal constraints. However, new techniques are not always immediately applicable since it is usually necessary for operators and other technical personnel to acquire experience and data over a period of time, to enable the technique to be applied consistently and effectively and to make accurate and useful interpretations of the test data possible. This is especially true for composite materials because of the complexity of these materials and their response.

It is also important to recognize that NDE techniques are best used in combination with each other. For example, while delaminations may be detected and characterized with C-scan equipment, x-ray devices probably will not resolve them very well, if at all. On the other hand, matrix cracks (or any cracks) that are oriented so they fall in a plane containing the incident beam direction

will generally not be resolved by a C-scan unit, while such an orientation is the optimum one for x-ray radiographic detection. For this and other reasons, C-scan and x-ray radiographic methods are best used together for the examination of composite materials. Since the strength, stiffness, and useful life of composite materials are controlled and influenced by a large number of microevents and microdetails, the determination of the integrity of these materials in a way that is directly associated with their behavior requires several different types of investigative methods and associated philosophies. It also requires that sound and quantitative relationships be established between the NDE activities and the mechanics and physics of the materials response, including the chemistry and thermodynamics of the manufacturing process. This is an almost impossible set of requirements, but the long-term success of the NDE of composite materials can be assured with no less.

## Nondestructive Evaluation of Flywheels

### Purpose and Function

It has been recently demonstrated that composite-material flywheels are capable of storing energy at a significantly greater energy density than flywheels made from metals. Composite-material flywheels that can store up to 36 Wh/lb have been successfully tested. In addition, composite flywheels are inherently safer for applications in vehicles and other devices, since the failure of such wheels does not produce large pieces of heavy material that become dangerous projectiles, but will generally produce a very large number of scattered particles in the form of dust and string or straw-like matter.

Composite flywheels are also thought to be durable since composite materials generally perform very well under long-term and fatigue loading, frequently better than metals. However, the relatively limited experience that has been gained in using composite materials in high-performance structures for long periods of time requires that special care be taken to verify the durability of any such design by experimental programs.

For our purposes, durability will be defined by the resistance to degradation of material properties and structural integrity, including damage

induced by cyclic loading and creep strain induced by time-at-load response. A more durable rotor is one that is degraded less by a given load spectrum, but one must be careful to define degradation in terms of engineering function. It is possible that one may observe damage or degradation that is of no consequence to the serviceability of the flywheel.

There is no general and complete analytical philosophy that can be applied to the description and prediction of the durability of composite materials. Hence it is necessary to use nondestructive evaluation (NDE) to establish mechanistic relationships between microfailure events such as matrix cracking, delamination and fiber fracture and macroresponse such as strength, stiffness, and useful life. From a practical standpoint we must be able to use NDE to answer three basic questions:

1. Has a given flywheel been manufactured and assembled properly, i.e., free of initial defects (of any consequence)?
2. Will a given type of flywheel meet all performance criteria during service based on the results of a (properly designed) test program?
3. What is the level of integrity and probable residual properties of a flywheel that is inspected by NDE following some service loading?

These three questions will be dealt with in more detail for some specific types of flywheels in the next section. In general, since there is not a great deal of systematic philosophy to use, significant data bases must be developed to support a successful effort to answer these three questions. A discussion of the NDE aspects of developing such a data base follows. It should be noted that the answer to question 2 requires a properly designed cyclic testing program that can be used to simulate all of the essential elements of the anticipated service environment so that durability can be established under realistic conditions. The proper design of such a test program is a separate (but critical) topic not addressed in this document. The interpretation of the results of such a test program must involve NDE considerations.

For example, when possible, failure mechanisms need to be defined in terms of measurable parameters such as the size of a delamination. Also, with this information in mind, designers can take into account the NDE detectability of these parameters to fabricate parts with maximum NDE inspectability. Qualitative NDE analysis can also provide information to the designer on process control and fabrication reproducibility<sup>77</sup> and to the mechanics analyst on the criticality of flaws.

The application of the various NDE methods requires a thorough understanding of the variables associated with each of the methods. As noted earlier, it is beyond the scope of this report to discuss all of the NDE techniques in detail and the variables affecting each method. Instead, as examples, radiographic and ultrasonic variables will be briefly reviewed. Data illustrating some of these variables will be presented.

## Radiographic Nondestructive Evaluation

Radiography is the nondestructive technique of inspecting a part using penetrating x and gamma radiation that is absorbed or scattered by the material under inspection. The radiation that penetrates the part is recorded either on film or by an image-sensing device. The recorded image is then evaluated. Factors that affect the recorded image when film is used include energy of the source, film type, source-to-film distance, density of the material under inspection, geometry of the part, collimation, radiation scattering, and exposure time. Many of these variables have been incorporated into technique charts to aid the

practitioner in choosing the proper operating conditions.

Several flywheels were radiographically inspected. The objective of the radiographic evaluation was to aid in the understanding of the fabrication procedures and to characterize the material. During radiography it was found that many trial exposures were required to obtain the best image quality.

### Hercules Flywheel

The first example involves a Hercules rotor [Fig. 1(a)], which has been manufactured by filament-winding graphite/polysulfone on a mandrel to form a contoured rim that is then shrink fitted onto a metallic hub. Figure 1(b) shows an x-ray radiograph of a section of such a rim following its manufacture. (All x-ray radiographs will be presented in reverse field in this report to take advantage of the additional detail that can be obtained from contact printing.) The arrows in Fig. 1(b) show regions of discontinuity in density, superimposed on the gradual variation in tone due to the tapered thickness of the wheel.

Figure 1(c) shows a video display of the Hercules rotor during spin testing (at Oak Ridge Flywheel Evaluation Laboratory, Oak Ridge, TN) at 21,000 rpm. In addition to the radial marks, which are painted reference positions, circumferential lines can also be seen. Three such lines are clearly visible. These lines were determined to be circumferential cracks that formed in the flywheel during the spin test. The cracks appear to coincide with the regions of discontinuous density identified in Fig. 1(b) from the radiograph. For example, the arrow in Fig. 1(c) indicates a crack that corresponds to the discontinuity indicated by the centermost arrow in Fig. 1(b). It is possible that the discontinuities shown in Fig. 1(b) correspond to resin-rich regions that were formed during irregularities in the filament-winding process. In any case, *it would appear that these discontinuities, as revealed by x-ray radiography, did influence the engineering performance of the flywheel.*

### Brobeck Flywheel

Radiographs in Figs. 2(b) and 2(c) show the S2-glass rings of two different Brobeck flywheels [Fig. 2(a)]. The Brobeck flywheel consists of a Kevlar-49/epoxy ring that is wound over a S2-glass/epoxy ring. The hub is separated from these rings by catenary-shaped Kevlar-29/epoxy tension-balanced spokes. A high-density step is

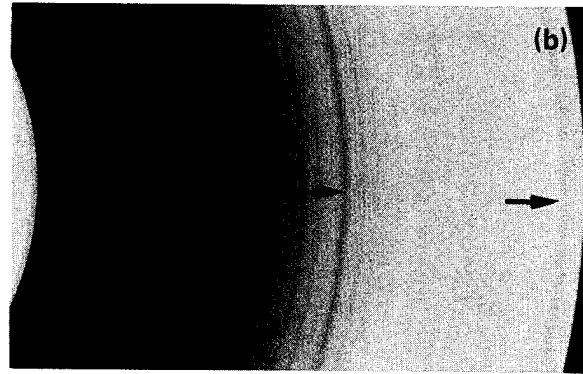

Figure 1. (a) Graphite/polysulfone filament-wound contoured rim (Hercules design). (b) Radiograph of Hercules flywheel showing three low-density rings. (c) Photograph from video recording of Hercules rotor during spin testing showing circumferential cracking in rim.

visible in Fig. 2(b). The likely cause of this variation is either an abrupt change in the filament-winding parameters or a temporary stoppage of the winding process.

#### Rocketdyne Flywheel

Obtaining an x-ray radiograph, such as the one shown in Fig. 1(b), requires some trial and error even for experienced operators. When a

structure such as a flywheel (which may involve various materials, thickness variations, and geometries) is radiographed, multiple trial exposures and exposure angles must be attempted. This is especially true if no specific type of flaw or defect is being sought, but a general survey is to be done. If a crack or defect of a specific type and orientation is to be detected, the plane of the defect should be parallel to the incident x-ray beam. In

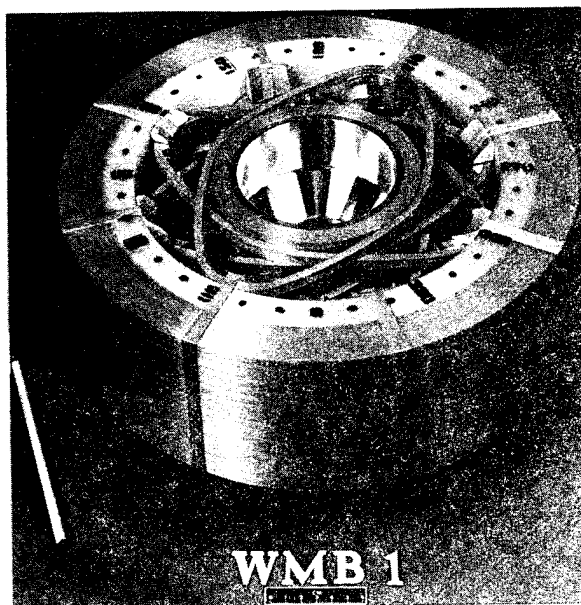

Figure 2. (a) Kevlar-49 S2-glass/epoxy rim with tension-balanced Kevlar-29 spokes (Brobeck design). (b) Radiograph of Brobeck flywheel showing high-density step (arrow) in S2-glass ring. (c) Radiograph of second Brobeck flywheel that did not show high-density step as in (b). Variation between flywheels is likely to be result of manufacturing-process control.

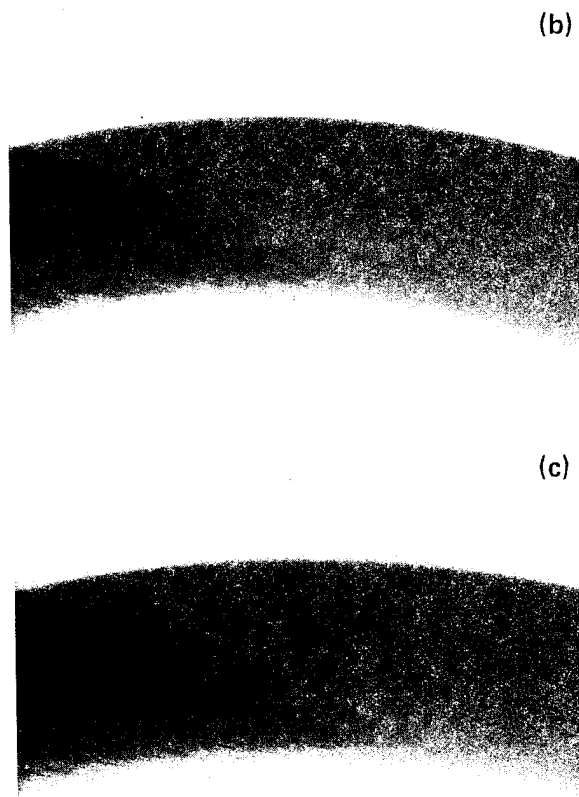

Fig. 1(b) the x-ray beam was parallel to the rotation axis of the flywheel. The discontinuities were also in the same plane. The circumferential cracks that formed during the spin test were also in that plane and extended through the thickness of the flywheel. Cracks or other defects in the plane of the flywheel would not be resolved by such an arrangement unless there were regions of significant depth in the direction of the incident x-ray beam.

Figure 3 shows the effect of alignment on x-ray radiographs for the Rocketdyne flywheel [Fig. 3(a)]. The flywheel consists of seventeen 5.1-mm-thick circumferentially wound graphite/epoxy layers on a twin-disk aluminum hub. Each layer was allowed to gel prior to winding the next layer. There is also a radial graphite/epoxy overwrap over the graphite/epoxy rim. Figures 3(b) and 3(c) show radiographs that were made under identical conditions, except that the position of the x-ray source was moved slightly. In Fig. 3(b) the x-ray source was positioned directly above the edge of the rim so that

discontinuities, which lie in the plane perpendicular to the radii of the wheel, would be perfectly (or nearly perfectly) aligned with the incident x-ray beam. In Fig. 3(c) the x-ray source was moved to the wheel axis position, a distance of about 30 cm. The loss of alignment due to that small change, for the source-to-specimen distance of 3.7 m, was sufficient to cause the image of the discontinuities to vanish.

#### Garrett AiResearch Flywheel

Figure 4(b) is an example of data obtained by proper alignment, energy, and source-to-film distance from the radiography of the Garrett AiResearch flywheel [Fig. 4(a)]. The rim of the Garrett flywheel is made up of 15 composite rings each separated by Teflon tape. The inner 2 rings are S2-glass, the middle 5 rings are Kevlar-29, and the outer 8 rings are Kevlar-49. After winding and curing of the outer rim, it is then deformed with a four-point press. The graphite/epoxy hub is then slipped into the rim. After releasing the press, the initially circular rim becomes subcircular. [Note

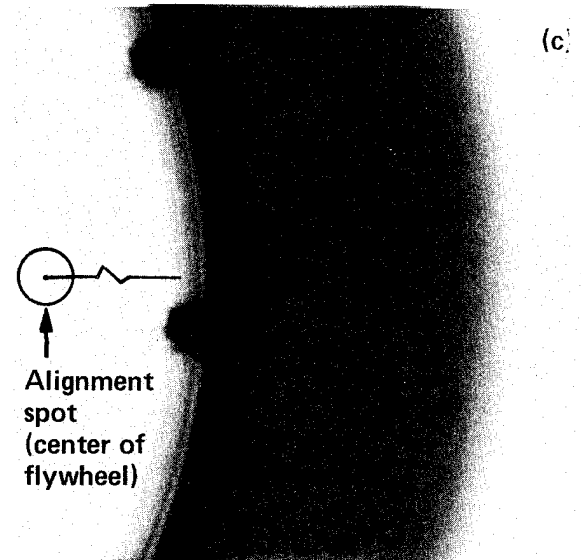
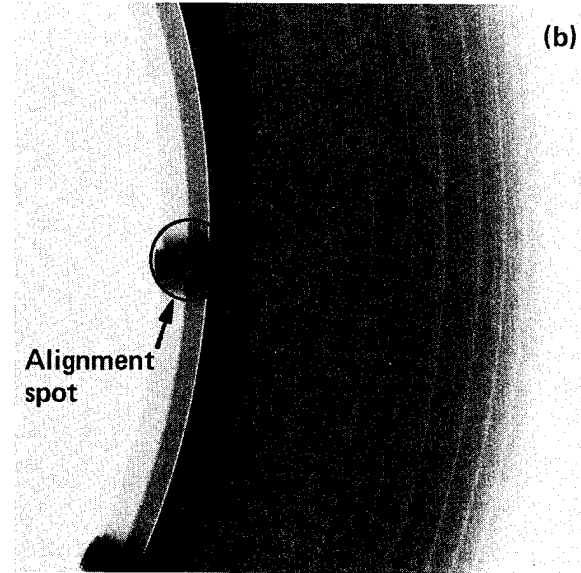
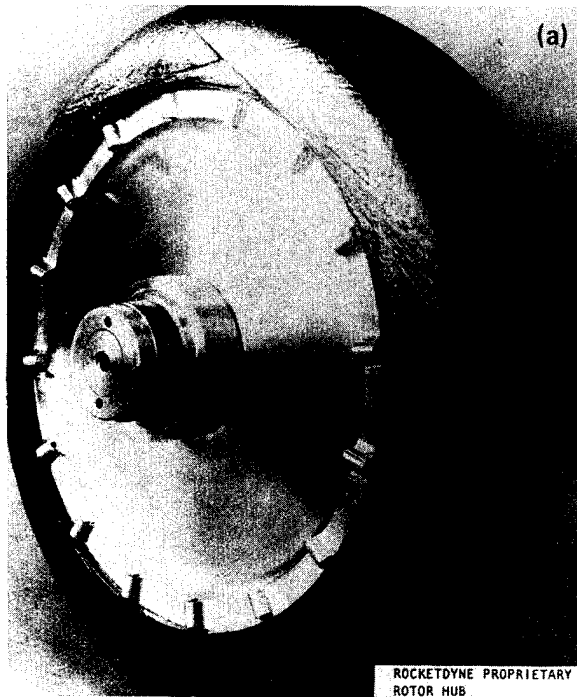

Figure 3. (a) Graphite/epoxy rim/overwrap with twin-disk hub flywheel (Rocketdyne design). (b) Radiograph of Rocketdyne rotor with x-ray source aligned with inside edge of rim. (c) Radiograph of Rocketdyne rotor with x-ray source aligned along its axis.

that the flywheel in Fig. 4(a) consists of two such rims.] Several density variations are detected such as the differences between the Kevlar-49, the Kevlar-29, and S-2 glass rings. A separation between rings is also noted by using high-energy (4 MeV) radiography. A tangential radiograph can be made to determine the depth of this separation. Figures 4(c) and 4(d) are the tangential radiographs taken with a collimated beam. Figure 4(c) is the tangent at the spoke where no separation was detected. Figure 4(d) is the tangent at the position indicated by the arrow in Fig. 4(d). The arrow in Fig. 4(d) shows the low-density indication of the possible separation in the lower rim of the flywheel.

#### Molded Sheet-Molding-Compound Disk/Filament-Wound Rim Flywheel

Another type of manufacturing detail is shown by the radiograph in Fig. 5(b). That radiograph was made from a constant-thickness disk rotor [Fig. 5(a)], about 25 cm in radius and fabricated from R65 sheet-molding compound (SMC) consisting of 65 wt% chopped S-2 glass in a polyester matrix. The disk was formed by stacking the material in a matched metal-die mold and curing it under high pressure and temperature. Figure 5(b) clearly shows that the material density near the edge of the disk is different from the remainder of the disk. This can be attributed to the flow

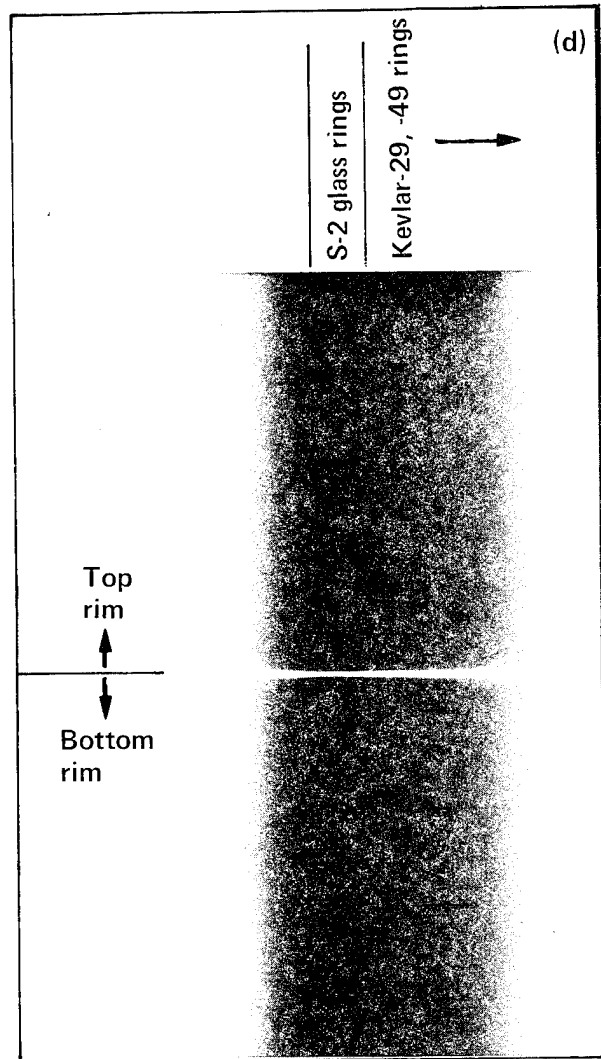
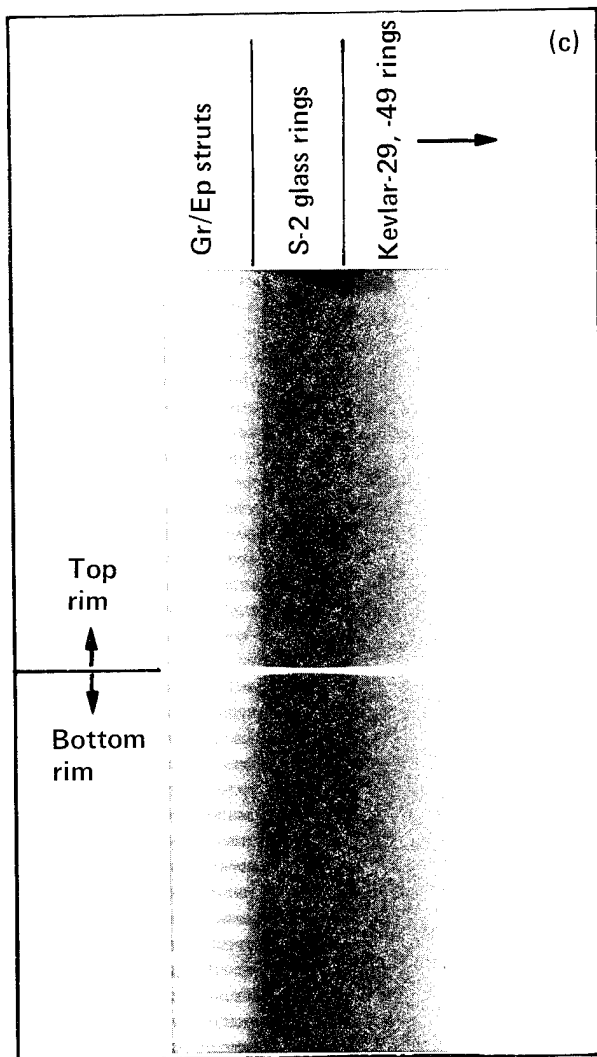
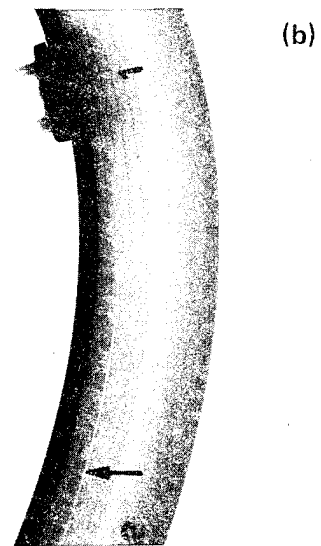
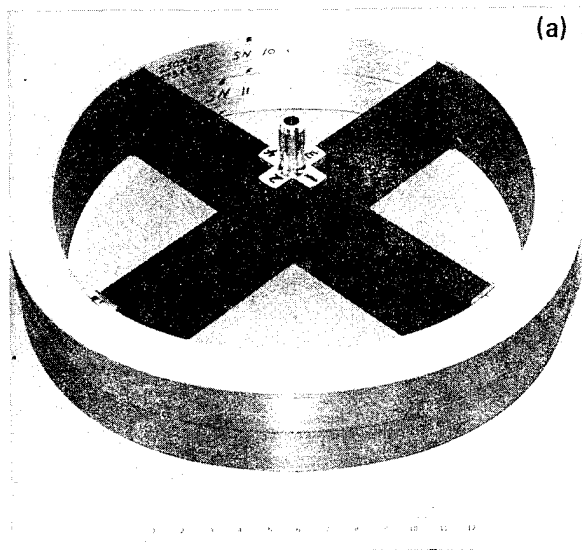

Figure 4. (a) Kevlar-49, Kevlar-29, and S2-glass/epoxy ring rim with graphite/epoxy cruciform hub flywheel (Garrett AiResearch design). (b) Radiograph of Garrett AiResearch flywheel showing density variations between Kevlar-49, Kevlar-29, and S2-glass. Arrow indicates site of separation between rings. (c) Tangential radiograph at site 1 of (b) indicates no separation. (d) Tangential radiograph at site 2 of (b) shows location and depth of separation.

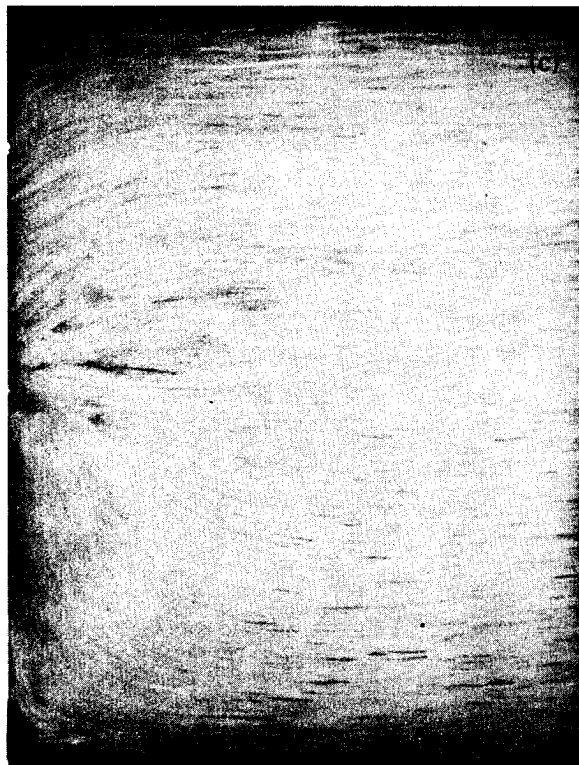
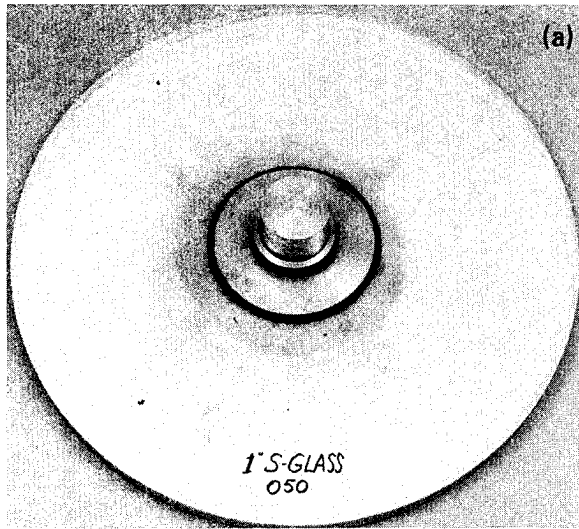

Figure 5. (a) Chopped S2-glass/polyester sheet-molding compound (SMC) molded disk fabricated by Owens-Corning. (b) Radiograph of SMC disk rotor showing material-density variations near edge caused by flow pattern of chopped fibers during fabrication. (c) Photomicrograph of molded SMC disk edge.

pattern of the chopped fibers during the curing process in the closed mold. As seen in the photomicrograph of the SMC disk in Fig. 5(c) (obtained from Owens-Corning), the fibers tend to align in a direction perpendicular to the plane of the disk along the edge. This accounts for the density variation in Fig. 5(b).

The radiographic technique can also be used to evaluate the rotor/hub elastomeric bond for disk-type flywheels. Alignment of the bond line

with the x-ray beam is critical to the proper interpretation of the radiographic image. The LLNL/Owens-Corning/Lord disk/ring flywheel shown in Fig. 6(a) was radiographed to evaluate the aluminum hub-to-flywheel bond. Figure 6(b) shows the radiograph of the bond line. An apparent gap was detected in the elastomeric bond. However, further evaluation of this gap revealed that the low-density radiographic image was caused by the outer graphite ring being imaged

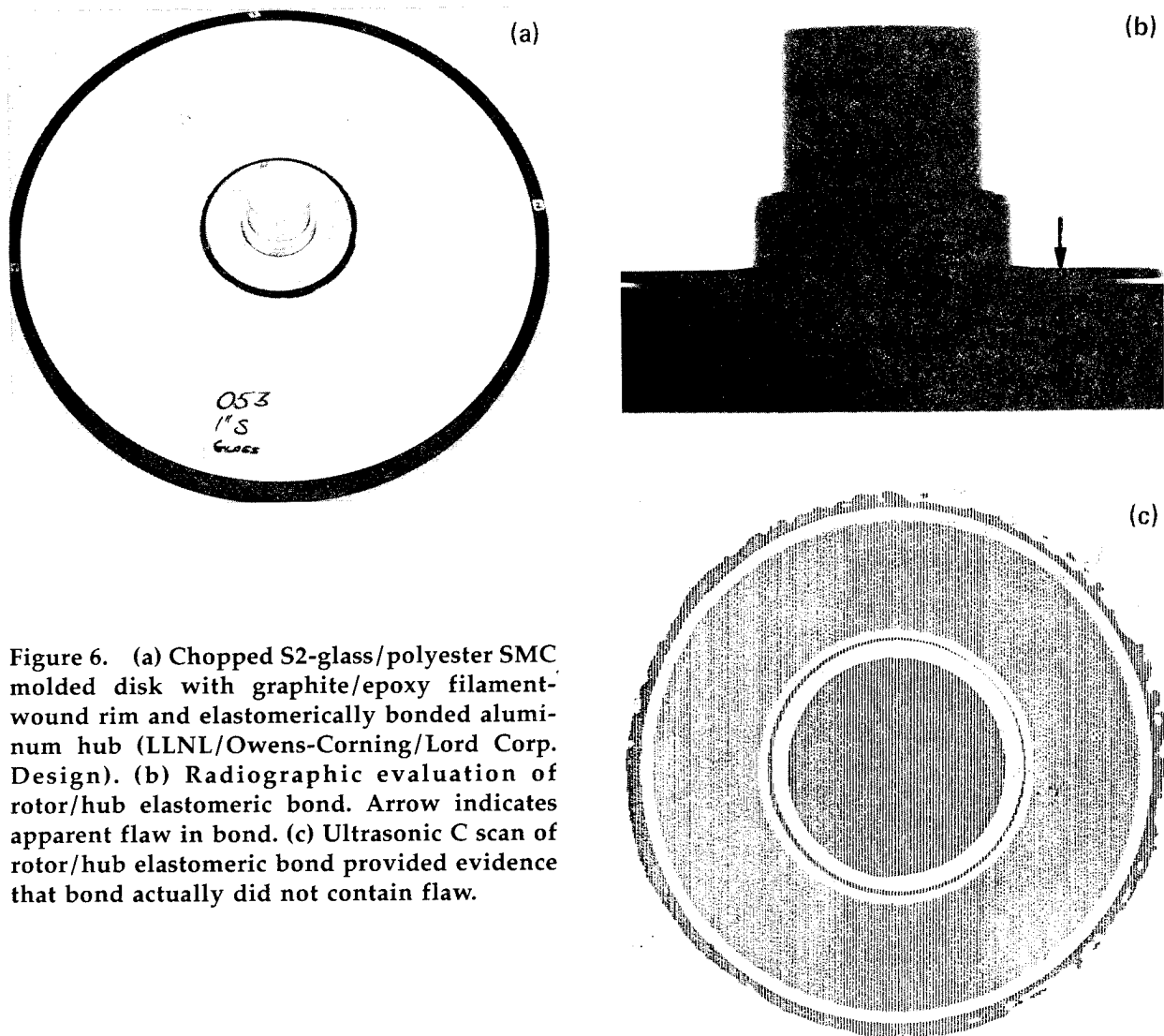

Figure 6. (a) Chopped S2-glass/polyester SMC molded disk with graphite/epoxy filament-wound rim and elastically bonded aluminum hub (LLNL/Owens-Corning/Lord Corp. Design). (b) Radiographic evaluation of rotor/hub elastomeric bond. Arrow indicates apparent flaw in bond. (c) Ultrasonic C scan of rotor/hub elastomeric bond provided evidence that bond actually did not contain flaw.

along the same line of sight as the bond area. Ultrasonic C scans of this bond [Fig. 6(c)] gave additional evidence that the gap was not present.

and failure modes of composite flywheels becomes available, the usefulness of radiography will be properly assessed.

#### AVCO Bidirectionally Woven Disk

The application of radiographic NDE to the AVCO spirally woven S2-glass cloth/epoxy laminate [Fig. 7(a)] is illustrated in Fig. 7(b). The cloth is reinforced radially and circumferentially. The radiograph in Fig. 7(b) (obtained from AVCO) shows not only the details of the weave pattern but also the petal-shaped radial flow pattern for the epoxy resin during molding of the laminate.

To ensure that proper radiographic techniques are used, all the variables need to be understood. As more information on the properties

#### Ultrasonic Nondestructive Evaluation

The nondestructive evaluation techniques that use ultrasonic waves have a different set of variables that need to be understood to properly use these methods. The ultrasonic frequency, size of the transducer, the couplant, properties of the material, geometry of the part, and fabrication procedures are a few of the more common variables affecting an ultrasonic inspection.

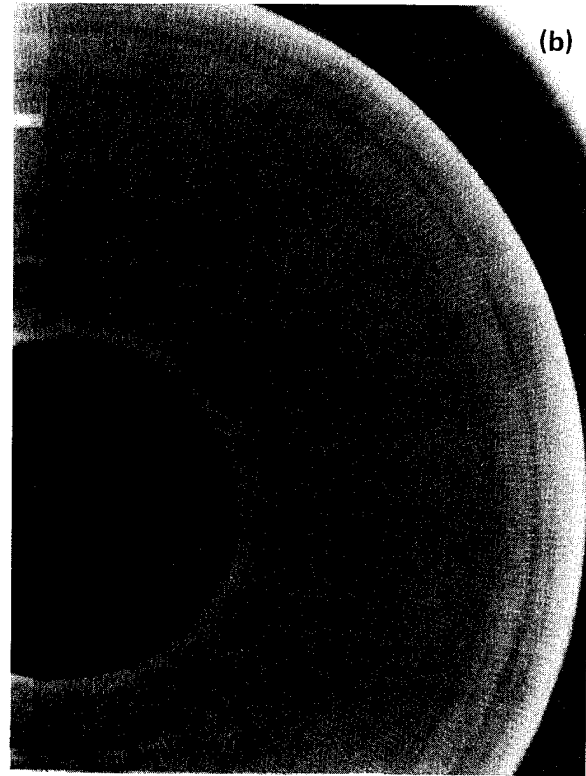
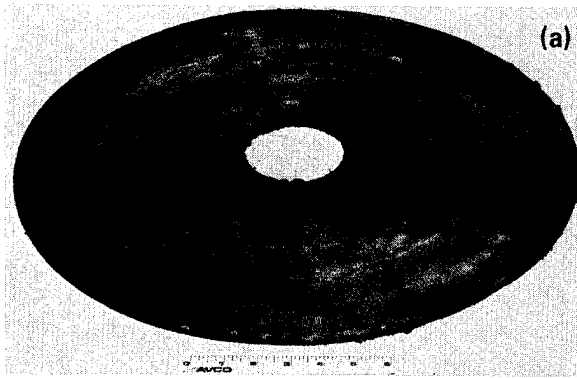

**Figure 7. (a) Bidirectionally reinforced woven S2-glass cloth/epoxy laminated disk (AVCO design). (b) Radiograph of AVCO disk showing weave pattern and resin flow direction during molding process.**

Ultrasonic inspection methods are often complementary to radiographic inspection because ultrasound is a sensitive indicator of very thin internal boundaries that have only minimal influence on radiographic opacity. This sensitivity may turn out to be a disadvantage in composite-material components that consist either of layers that are bonded together or of layers that are cured in stages during the winding or other fabrication process. Either procedure results in internal boundaries with varying ultrasound transmission characteristics. This gives rise to numerous reflections that may have no relationship to defects, but instead are related to the specific fabrication method. Since rim-type flywheels are often fabricated in layers that are cured in stages, existence of such boundaries is common [see, for example, Fig. 3(b)]. In addition, the circular geometry of the rim will further complicate the interpretations of ultrasonic wave reflections and scattering. Therefore, for these flywheels a reliable ultrasonic inspection procedure could not be developed. For some prototype rim-type flywheels, where water immersion was not allowed, a hand-scan technique was used. This technique also failed to provide useful information.

### Laminated Composite Panels

Laminated composite panels that were later machined into the required flywheel contour were also ultrasonically inspected. The pulse-echo technique was used for recording the signal information. Ultrasonic C scans were made by measuring the change in back-surface reflection and by gating the signal to measure the internal reflections. Typical C scans of a 1-in.-thick graphite/epoxy panel [from which a tapered thickness contour was subsequently machined (Fig. 8(a))] are shown in Figs. 8(b)–8(e). The panel was  $26 \times 26 \times 1$  in. and inspected using a 2.25-MHz transducer. Figures 8(b) and 8(c) show the loss of back-surface reflected amplitude for C scans of the front and back surfaces, respectively. Figures 8(d) and 8(e) are the C scans obtained by gating the internal 2/3 of the panel for front- and back-surface incidence, respectively. In these C scans the dark areas indicate the scatter sites. The outer edges of this panel were nominally thinner causing the recorded signal variation in the C scans for the internal gating situation.

It should be pointed out here that the large defect areas that are evident in Figs. 8(b) and 8(c)



(a)

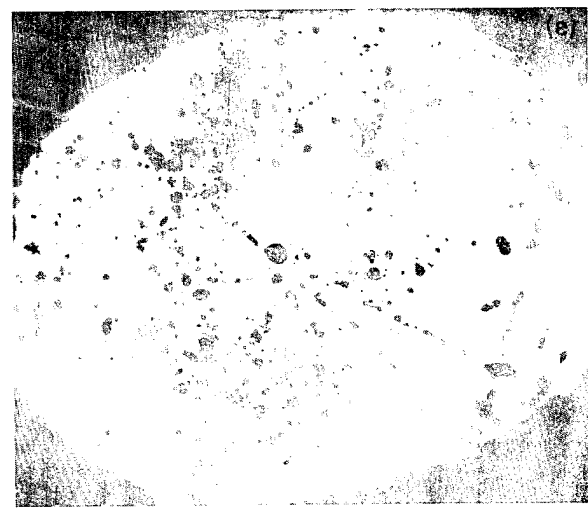
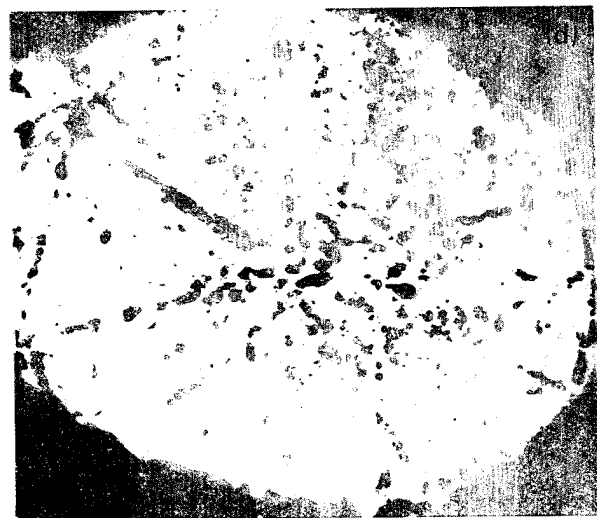

Figure 8. (a) LLNL tapered-thickness graphite/epoxy laminated disk. (b) Ultrasonic C scan of graphite/epoxy panel gating loss of back-surface reflection from front. (c) Ultrasonic C scan of graphite/epoxy panel gating loss of back-surface reflection from back. Note that (b) and (c) are mirror images. (d) Ultrasonic C scan of graphite/epoxy panel gating internal scattering from front. (e) Ultrasonic C scan of graphite/epoxy panel gating internal scattering from back. Note that (d) and (e) do not show as mirror images.

are not delaminations. Instead they represent widespread microporosity in the laminate, which

has probably resulted from moisture entrapment during the curing process.

## Post-Spin Test Nondestructive Evaluation of Flywheels

As part of the durability and useful-life assessment program, cycle (fatigue) testing has been initiated. Damage resulting from the cyclic loading can be determined by post-cycle nondestructive inspection. Two flywheels that were evaluated after subjecting them to loading cycle(s) will be described here.

### LLNL Constant-Thickness Laminated Disks

In addition to the burst tests, the S2-glass and graphite/epoxy constant-thickness laminated disks [Figs. 9(a) and 10(a)] were tested to the maximum speed of about 60% of their expected failure speed and examined ultrasonically in an attempt to identify the accumulation of matrix damage.<sup>5</sup>

For the S2-glass/epoxy disk, damage around the edge was evident after spinning it to 30,000 rpm [Figs. 9(b) and 9(c)]. For the graphite/epoxy disk, however, no significant damage was detected after 35,000 rpm [Figs. 10(b) and 10(c)].

There are a number of factors that may be active in the outside regions of a laminated disk that could degrade the laminate there as in Fig. 9(c). First, edge effects near free edges of laminates create interlaminar normal and shear stresses that can lead to delamination. Second, the outside regions of the laminated disks manufactured in this program are most susceptible to degradation of strength because of process-related effects. Third, the machining of the outside disk boundary could also introduce damage capable of reducing laminated strength.

To gain a more quantitative measure of the material state in the disk after spinning, velocities of waves propagating through the S2-glass/epoxy disk thickness were also measured. The matrix cracking predicted by the failure analysis results in a reduction in stiffness of the composite. This stiffness reduction would then appear as a decreased speed of sound in the damaged material when compared with undamaged material. The acoustic velocities were measured at a number of locations along the disk radius to determine how they varied in space. Both longitudinal and

shear-wave speeds were measured. To obtain an indication of what these wave speeds are in a disk before spinning, similar tests were also made on another laminated S2-glass/epoxy disk. This disk was made of the same material and was processed identically.

There are several interesting things to note in the results of these acoustic velocity studies as presented in Fig. 11. First, both the longitudinal as well as the shear velocity are higher at all locations in the unspun disk than they are in the disk spun to a tip speed of 638 m/s. In addition, although the longitudinal wave speeds are constant over the entire radius of the unspun laminated disk, there is a visible variation in both the longitudinal and the shear-wave speeds with respect to radial location in the disk after spinning. In both cases the wave speeds are slower in the interior regions of the disk with gradually increased values as the outside radius of the disk is approached. In the case of the longitudinal wave, the velocity near the outside radius approaches the velocity measured in the unspun wheel. This behavior agrees quite well with the analytical prediction of progressive matrix failure that moves outward radially as the rotational speed of the wheel is increased. The gradual increase in the shear-wave speed for the unspun disk is not understood presently.

Another interesting phenomenon is visible in the shear-wave speed data. The shear waves introduced in this test propagate through the disk thickness. The particle motion induced by the transducer can be varied by rotating the transducer. As part of this investigation, wave speeds were measured for particle motion in both the radial and the tangential directions. As expected, these wave speeds are the same in the unspun disk. They are also the same in the interior regions of the disk that was spun. However, in the outer 20% of the spun disk, the wave speed associated with radial particle motion is higher than the speed associated with tangential motion and indicates an anisotropy in material properties that is not present in the original disk. The difference in these wave speeds seems to be maximum near the radius where the longitudinal wave speed begins

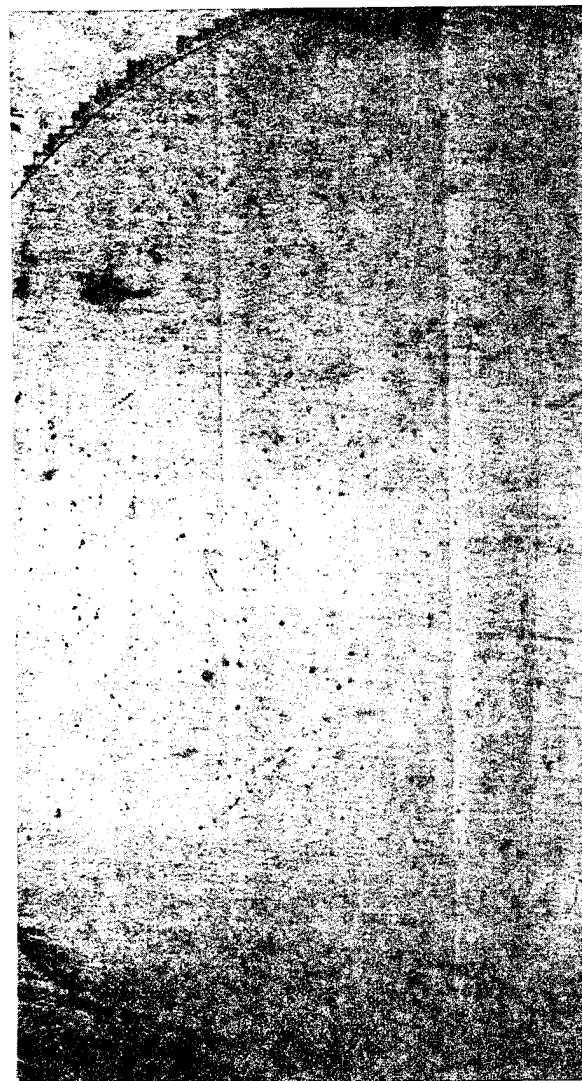
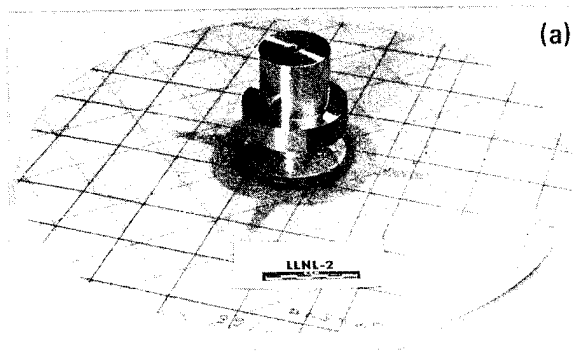
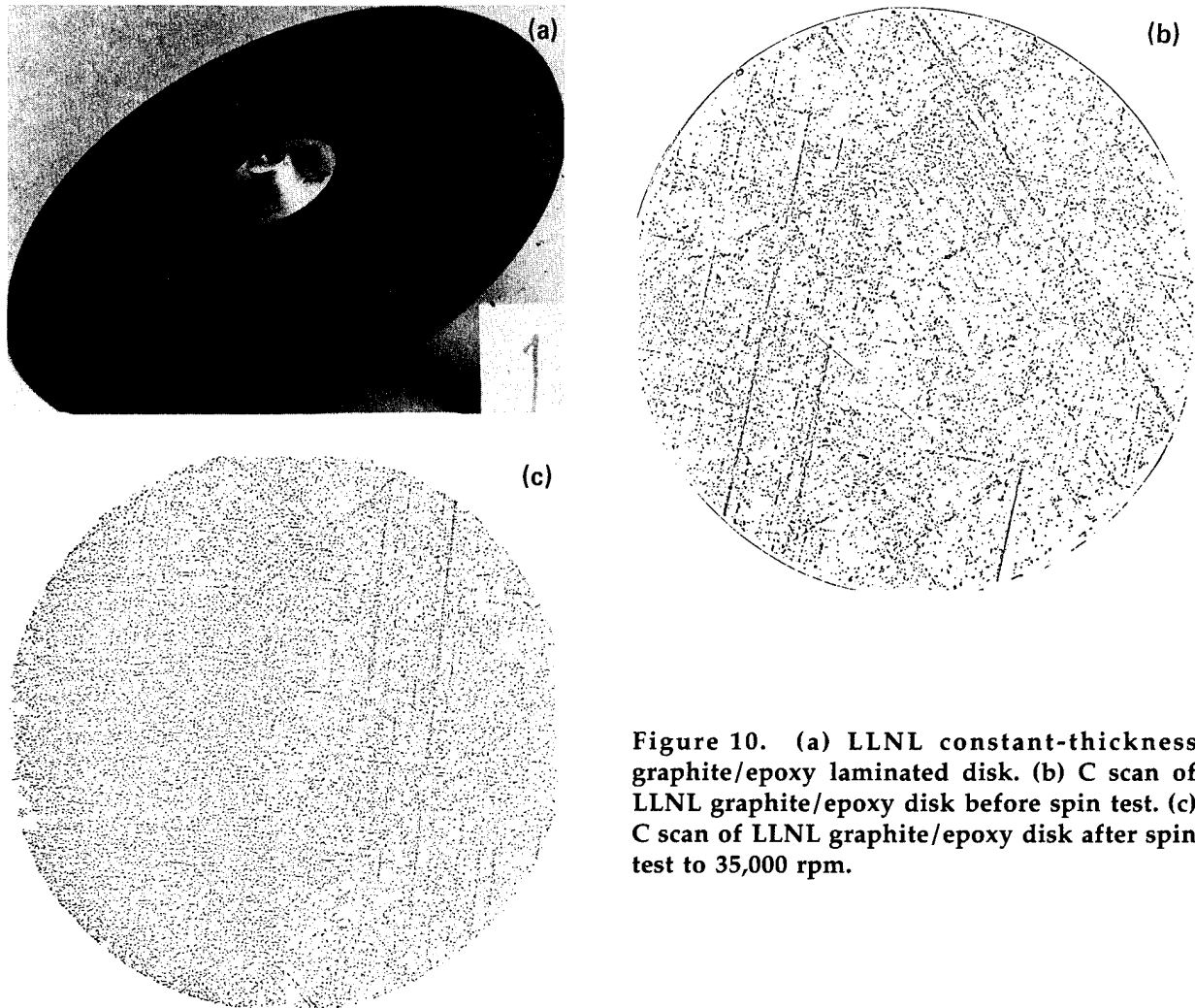

Figure 9. (a) LLNL constant-thickness S2-glass/epoxy laminated disk. (b) C scan of LLNL S2-glass disk before spin test. (c) C scan of LLNL S2-glass/epoxy disk after spin test to 30,100 rpm.

to increase and may be associated with the onset of matrix damage. Since the stress field in this area is increasingly uniaxial, the damage occurring in the laminates no longer occurs in all laminae simultaneously. Instead, transverse microcracks will occur in the more radially oriented laminae first. Although these microcracks would lower shear moduli and wave speeds associated with tangential particle motion, the shear waves associated with radial particle motion may not be sub-

stantially affected since the fibers in the damaged layers would be the major contributor to shear modulus in these layers and these fibers are not damaged. This explanation, however, does not account for the reduction in radial-particle motion (shear-wave speed) in the outer 3-4 cm of the disk.

Even though not all of the experimental data can be completely explained, the general trend seems to corroborate the analytical expectation of



**Figure 10. (a) LLNL constant-thickness graphite/epoxy laminated disk. (b) C scan of LLNL graphite/epoxy disk before spin test. (c) C scan of LLNL graphite/epoxy disk after spin test to 35,000 rpm.**

matrix microcracks, which cover a substantial portion of the flywheel disk at speeds below ultimate failure. Although this damage can easily accumulate without causing the failure of the wheel, its presence and continued growth probably contribute to the ultimate failure.

### **Garrett Near-Term Electric-Vehicle Flywheel**

The Garrett near-term electric vehicle (NTEV) flywheel, shown in Fig. 12(a), is similar to the Garrett flywheel shown in Fig. 4(a). The NTEV flywheel has nine separate composite rings and an aluminum spoke and hub assembly. A radiographic inspection of the composite rim was made

at LLNL after 1000 cycles of spin testing (at Garrett AiResearch). Figure 12(b) shows an axial radiograph of the rim. The arrow indicates the separation between the S2-glass and the Kevlar rings. The separation has apparently increased with the number of cycles because of the creep in the Kevlar-29 and Kevlar-49 rings. A tangential radiograph of the rim, shown in Fig. 12(c), indicates the presence of a possible radial crack through the rings. The arrows in Fig. 12(c) suggest that the crack extends around the entire flywheel.

Although pretest radiographs were not obtained for the Garrett NTEV rotor, it is possible that the damage indicated by the tangential radiographs was caused by fatigue cycling. Further testing of this part should include radiographic inspection to monitor the growth of damage.

Vibrothermography was also used to inspect the Garrett NTEV rotor. Figure 13 shows a sketch of the heat pattern that developed in the same flywheel. The heat pattern was excited by pressing a metal contact piece machined to the inside radius of the wheel against that surface and driving it in the kHz range with a solenoid-type oscillator. As noted earlier, the layers of glass/epoxy and Kevlar/epoxy that are not bonded together are separated somewhat and formed free surfaces as indicated by the development of heat sources near the spoke areas. Vibrothermography is very sensitive to internal surfaces that rub together and produce heat when the excitation frequency is adjusted to excite resonant vibrations of the flaw surfaces. The frequencies that produced heat patterns in this case were in the 10–12 kHz range.

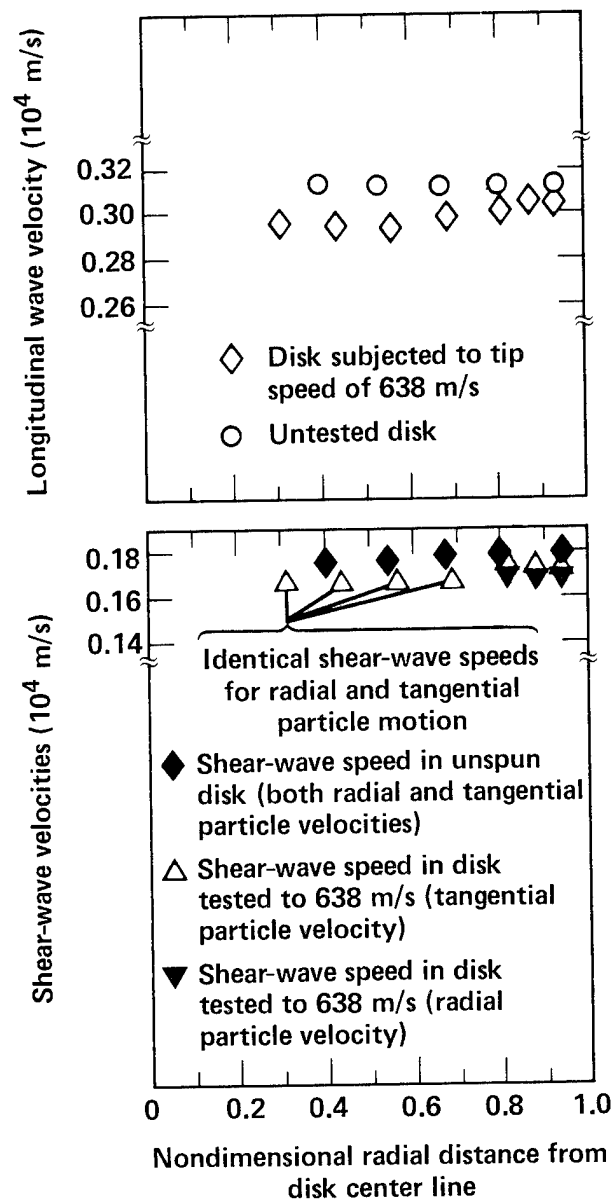

Figure 11. Comparison of through the thickness longitudinal and shear-wave speeds in LLNL S2-glass/epoxy disk before and after spin testing.

## Summary

Several examples of nondestructive evaluation of flywheels prior to spin testing and two examples of post-cyclic nondestructive testing have been described. The importance of such NDE cannot be overstated. As mentioned earlier, a damage philosophy like fracture mechanics in homogeneous materials has not been developed for composite materials. Therefore it is very difficult to answer our third basic question that we posed earlier: What is the level of integrity and probable residual properties of a flywheel that has been

subjected to some loading history? Until this philosophy is developed we must adopt a basic approach. We must use NDE techniques to measure the integrity of the flywheel during cyclic testing (or during service). We must identify changes in the integrity that occur as the loading progresses. We must also determine the residual properties of the flywheels when those changes are observed. When that has been done, the residual properties of any flywheel can be implied from NDE measurements without additional testing.

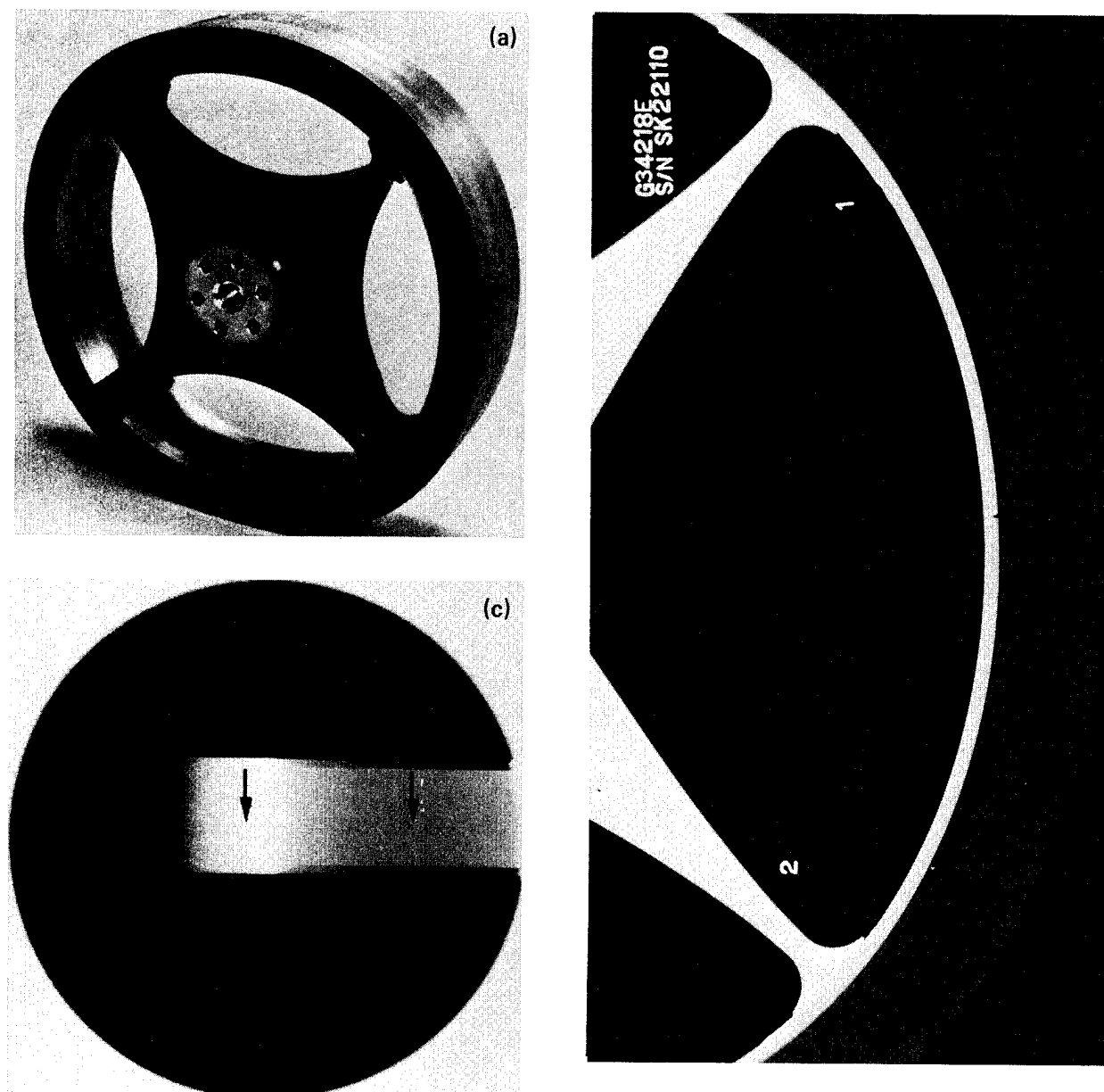
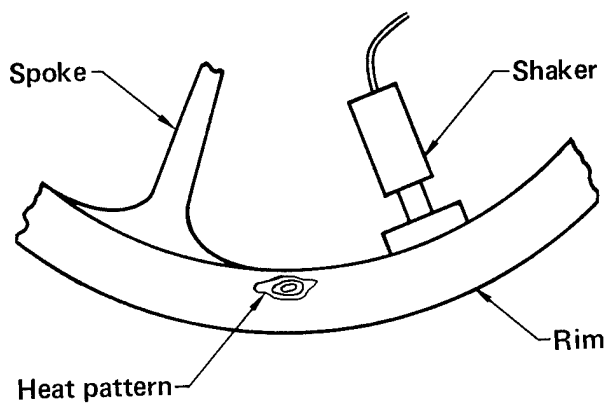

Figure 12. (a) Kevlar-49, Kevlar-29, and S2-glass/epoxy ring rim with aluminum hub flywheel (Garrett AiResearch NTEV design). (b) Radiograph of Garrett AiResearch NTEV flywheel. Arrow indicates separation between S2-glass and Kevlar rings. (c) Tangential radiograph of Garrett AiResearch NTEV flywheel detected possible radial crack through Kevlar rings. Arrows suggest crack extends around entire flywheel.

We have reached this level of development for many situations involving homogeneous materials. By measuring single crack lengths and using one of several generalizations of fracture mechanics, it is possible to estimate the remaining strength and useful life of a given component with accuracy sufficient for many engineering applications. It is not easy to identify a cor-

responding scheme for composite materials. Degradation usually involves a complex combination of matrix cracking, debonding, delamination, and fiber fracture, or several different combinations through the useful life of the material or component. It is therefore not possible to try to account for every crack or microdefect individually as they occur. Instead, some measurement of integrity



**Figure 13. Sketch of vibrothermography heat pattern and excitation method for inspection of rim of Garrett AiResearch NTEV rotor.**

that is sensitive to the collective effect of these defects must be used. It must also be possible to establish some quantitative relationship between the measurements made using such a scheme and the residual properties. At the very least, this relationship can be empirical. For example, perhaps it is found that when matrix cracking, as resolved by C scans or radiographs or other schemes, has spread throughout two thirds of the rotor volume, rotor failure is imminent and the device should be retired from service.

Some of the new NDE techniques still under development may be of even greater use to residual property-determination efforts. One example is the use of stiffness as a damage indicator and quantitative measure of degradation. It has been found that changes in stiffness accompany damage development in composite materials, as discussed earlier. If these changes can be related to residual flywheel strength and useful life, an ex-

cellent NDE scheme results. Measuring the stiffness of a flywheel is not a simple task because of the circular geometry and the difficulty one has in loading the wheel. Several possibilities exist, however. Stiffness changes could be detected by measuring strain during spin testing. Such tests would require that strain gages be mounted on the wheel with slip-ring connections to the instrumentation, or that one of several optical-strain measurement schemes be used. Such measurements should be made at several positions on the flywheel to detect damage in different regions. Measuring strain during spin testing is especially appealing in the sense that the stress field that determines the residual strength and useful life of the flywheel provides the deformation field that is measured. Hence, changes in the deformation field should be more directly related to changes in the residual properties than any other imposed stress or strain field. However, other methods are available. The characteristic resonant frequencies of the flywheel are very sensitive to material stiffness. It may be possible to correlate those shifts with changes in residual strength or residual life.

The availability of NDT equipment and other constraints may limit the use of NDE during the testing of composite flywheels. However, nondestructive evaluation is the only way to learn something about the process of damage developments that define the residual properties of composite flywheels. Only by understanding (or at least representing) those processes can we correctly anticipate the performance and safety of the structure. Without this capability, we must pay the (very great) price of extensive testing over all possible conditions and time periods of loading to ensure the satisfactory performance and safety of composite flywheels.

## References

1. R. D. Kriz and W. W. Stinchcomb, *Mechanical Properties for Thick Fiber Reinforced Composite Materials Having Transversely Isotropic Fibers*, College of Engineering, Virginia Polytechnic Institute and State University, Blacksburg, VA, Report No. VPI-E-77-13 (1977).
2. E. G. Henneke II and J. C. Duke, *A Review of the State-of-the Art of Nondestructive Evaluation of Advanced Composite Materials*, for Union Carbide Corporation, Oak Ridge National Laboratory, Oak Ridge, TN, Report No. 19-X-13673V (1979).
3. C. N. Owston, "Carbon Fibre Reinforced Polymers and Non-Destructive Testing," *Brit. J. NDT* **15**, 2 (1973).
4. D. T. Hayford, E. G. Henneke, and W. W. Stinchcomb, "The Correlation of Ultrasonic Attenuation and Shear Strength in Gr/Polyimide Composites," *J. Comp. Matl.* **11**, 429 (1977).
5. R. P. Nimmer, K. Torossian, and J. Hickey, *Laminated Composite Disk Flywheel Development*, Lawrence Livermore National Laboratory, Livermore, CA, UCRL-15301 (1980).
6. G. P. Sendeckyj, H. D. Stalnaker, and R. A. Kleismit, "Effect of Temperature on Fatigue Response of Surface-Notched Gr/Ep Laminates," in *Fatigue of Filamentary Composite Materials* (American Society for Testing and Materials, Philadelphia, PA, 1976), ASTM STP 636, pp. 123-140.
7. N. R. Adsit and J. P. Waszczak, "Investigation of Damage Tolerance of Gr/Ep Structures," AD-A038936, General Dynamics, Convair Division, San Diego, CA (1976).
8. B. G. Martin, "Ultrasonic Wave Propagation in Fiber-Reinforced Solids Containing Voids," *J. Appl. Phys.* **48**, 3368 (1977).
9. D. T. Hayford and E. G. Henneke, "Theory of Ultrasonic Diffraction by Damage Developed in Thin Laminated Composites," Virginia Polytechnic Institute and State University, Blacksburg, VA, NASA-CR-155161, 1977.
10. K. L. Reifsnider, E. G. Henneke, and W. W. Stinchcomb, "Defect-Property Relationships in Composite Materials," Wright Patterson Air Force Base, OH, AD-A031809 (1976).
11. K. L. Reifsnider, E. G. Henneke, and W. W. Stinchcomb, "Defect-Property Relationships in Composite Materials, Part II," Wright Patterson Air Force Base, OH, AFML-TR-76-81-PT-2, AD-A052358 (1977).
12. B. G. Martin, "Ultrasonic Attenuation Due to Voids in Fibre-Reinforced Plastics," *NDT Intern.* **9**, 242 (1976).
13. A. Vary and K. J. Bowles, "Ultrasonic Evaluation of the Strength of Unidirectional Gr-Polyimide Comps.," 11th Symp. on NDE, Southwest Research Institute, San Antonio, TX (April 1977).
14. A. Vary and K. J. Bowles, "Use of an Ultrasonic-Acoustic Technique for Nondestructive Evaluation of Fiber Composite Strength," in *Proceedings Plastics/Composites Institute, 33rd Annual Conf., Washington, DC, Feb. 7-10, 1978, pp. 2A1-A5.*
15. A. Vary and R. F. Lark, "Correlation of Fiber Composite Tensile Strength with the Ultrasonic Stress Wave Factor," NASA-Lewis Research Center, Cleveland, OH, NASA-TN-78846, 1977.
16. M. Meron, Y. Bar-Cohen, and O. Ishai, "NDE of Strength Degradation in Glass-Reinforced Plastics as a Result of Environmental Effects," *J. Test. Eval.* **5**, 394 (1977).
17. D. H. Kaelble, P. J. Dynes, L. W. Crane, and L. Maus, "Interfacial Mechanisms of Moisture Degradation in Gr-EP Composites," *J. Adhesion* **7**, 25 (1974).
18. R. M. Verette, "Temperature/Humidity Effects on the Strength of Gr/Ep Laminates," in *AIAA Aircraft Systems and Tech. Meeting, Los Angeles, CA, Aug. Paper 75-1011, A75-39512* (1975).
19. D. H. Kaelble and P. J. Dynes, "Methods for Detecting Moisture Degradation in Gr/Ep Composites," *Mater. Eval.* **35**, 103 (1977).
20. R. Prakash and C. N. Owston, "Ultrasonic Determination of Lay-Up Order in Cross-Plied CFRP," *Composites* **8**, 100 (1977).
21. J. J. Nevadunsky, J. J. Lucas, and M. J. Salkind, "Early Fatigue Damage Detection in Composite Materials," *J. Comp. Matl.* **9**, 394 (1975).
22. J. H. Williams Jr. and S. S. Lee, "Acoustic Emission Monitoring of Fiber Composite Materials and Structures," *J. Comp. Matl.* **12**, 348 (1978).
23. D. E. W. Stone and P. F. Dingwall, "The Kaiser Effect in Stress Wave Emission Testing of Carbon Fiber Composites," *Nature Phys. Sci.* **241**, 68 (1973).

24. E. Y. Robinson, *A Basic Model for Acoustic Emission For Fiber-Reinforced Material*, TM-53-564, NAS7-100, Jet Propulsion Laboratory, Pasadena, CA, 1972.
25. E. Y. Robinson, "AE Studies of Large Advanced Composite Rocket Motor Cases," *28th Ann. Tech. Conf., 1973 Reinforced Plastics/Composites Inst., Society of Plastics Ind., Inc., Sec. 12-D, (1973)*, pp. 1-6.
26. H. C. Kim, A. P. Ripper Neto, and R. W. B. Stephens, "Some Observations on AE During Continuous Tensile Cycling of a Carbon Fiber/Epoxy Composite," *Nature Phys. Sci.* **237**, 78 (1972).
27. F. H. Chang, D. E. Gordon, and A. H. Gardner, "A Study of Fatigue Damage in Composites by NDT Techniques," in *Fatigue of Filamentary Composite Materials* (American Society for Testing and Materials, Philadelphia, PA, 1976), pp. 57-72.
28. M. J. Fry, "AE from Carbon Fiber Reinforced Carbon Composites," Procurement Executive-Ministry of Defense, Atomic Weapons Research Establishment, UK, AWRE Ref. No. 0 42/76 (1977).
29. S. S. Russell and E. G. Henneke, *Signature Analysis of AE from Gr/Ep Comps.*, VPI-E-77-22, College of Engineering, Virginia Tech, Blacksburg, VA (1977).
30. D. M. Egan, and J. H. Williams, "AE Spectral Analysis of Fiber Composite Failure Mechanisms," NASA-Lewis Research Center, Cleveland, OH, NASA-CR-2938, 1978.
31. A. Rotem and E. Altus "Fracture Modes and Acoustic Emission of Composite Materials," *J. Test. Eval.* **7**, 34 (1979).
32. A. Rotem, "Effect of Strain Rate on AE from Fiber Comp," *Composites* **9**, 33 (1978).
33. A. Rotem, "The Estimation of Residual Strength of Composites by Acoustic Emission," Selective Application of Materials for Products and Energy, *Proc. 23rd Natl. Symp. Exhibit., Anaheim, CA, May 2-4, 1978, SAMPE*, pp. 329-353.
34. A. F. Weyhreter and C. R. Horak, "Acoustic Emission System for Estimation of Ultimate Failure Strength and Detection of Fatigue Cracks in Composite Materials," *Proc. Soc. Plastics Industry, Inc., Reinforced Plastics/Composites Inst., 33rd Annual Conf., Washington, DC, Feb. 7-10, 1978*, pp. 24-B1-B5.
35. R. S. Williams and K. L. Reifsnider, "Investigation of AE during Fatigue Loading of Composite Specimens," *J. Comp. Matl.* **8**, 340 (1974).
36. T. T. Chiao, E. S. Jessop, and M. A. Hamstad, *Performance of Filament-Wound Vessels from an Organic Fiber in Several Epoxy Matrices*, Lawrence Livermore National Laboratory, Livermore, CA, UCRL-76913 (1975).
37. M. A. Hamstad, "Variabilities Detected by Acoustic Emission from Filament-Wound Aramid Fiber/Epoxy Composite Pressure Vessels," *Intern. Instrum. Symp., 24th, Albuquerque, NM, May 1-5, 1978 Proceedings, Part 2, Instrum. Soc. Am.*, pp. 419-431 (1978).
38. M. A. Hamstad and T. T. Chiao, "AE from Stress Rupture and Fatigue of an Organic Fiber Composite," in *Composite Reliability* (American Society for Testing and Materials, Philadelphia, PA, 1975), STP 580, pp. 191-201.
39. M. A. Hamstad and T. T. Chiao, "AE Produced During Burst Tests of Filament-Wound Bottle," *J. Comp. Matl.* **7**, 320 (1973).
40. M. A. Hamstad and T. T. Chiao, "Structural Integrity of Fiber/Epoxy Vessels by AE," *SAMPE Quarterly* **8**, 31 (1976).
41. M. A. Hamstad and R. G. Patterson, "Considerations for AE Monitoring of Spherical Kevlar/Ep Composite Pressure Vessels," in *Composites in Pressure Vessels and Piping* (American Society of Mechanical Engineers, NY, 1979), S.V. Kulkarni and C.H. Zweben, Eds.
42. M. A. Hamstad, *Acoustic Emission for Quality Control of Kevlar Filament-Wound Composites*, Lawrence Livermore National Laboratory, Livermore, CA, UCRL-83783 (1980).
43. *Mechanics of Nondestructive Testing* (Plenum Press, NY, 1980), W.W. Stinchcomb, Ed., pp. 101-121.
44. T. K. O'Brien, *An Evaluation of Stiffness Reduction as a Damage Parameter and Criterion for Fatigue Failure in Composite Materials*, Ph.D. thesis, Virginia Polytechnic Institute and State University, Blacksburg, VA (1978).
45. A. Highsmith and K. L. Reifsnider, "Stiffness-Reduction Mechanisms in Composite Laminates," *Proc. Symp. Damage in Composite Materials, Bal Harbor, FL, 1980* (American Society for Testing and Materials, Philadelphia, PA, 1982).
46. K. L. Reifsnider and A. Highsmith, "The Relationship of Stiffness Changes in Composite Laminates to Fracture-Related Damage Mechanisms," *Proc. Second USA-USSR Symposium on Fracture of Composite Materials, Lehigh University, Bethlehem, PA, March 1-29, 1981*.

47. G. R. Irwin and J. A. Kies, "Critical Energy Rate Analysis of Fracture Strength," *Welding J. Res. Suppl.* **33**, 193S (1954).
48. G. R. Irwin, "Fracture," in *Handbuch Der Physik* (Springer Verlag, NY, 1958) Vol. 6, p. 551.
49. G. L. Roderick, "Stiffness Change During Fatigue of Composite Materials," *Proc. Fifth Annual Mech. Composites Rev., AFWAL-TR-80-4020, Air Force Wright Aeronautical Laboratories, Wright-Patterson Air Force Base, OH* (1980).
50. T. K. O'Brien, "Delamination Growth in Composite Laminates," *Proc. Symp. Damage in Composite Materials, Bal Harbor, FL, 1980* (American Society for Testing and Materials, Philadelphia, PA, 1982).
51. W. S. Johnson, *Characterization of Fatigue Damage Mechanism in Continuous Fiber Reinforced Metal Matrix Composites*, Ph.D. thesis, Duke University, Durham, NC (1979).
52. M. J. Salkind, "Fatigue of Composite Materials," *Composite Materials: Testing and Design (Second Conference), ASTM STP-497, 1972* (American Society for Testing and Materials, Philadelphia, PA, 1972).
53. J. J. Nevadunsky, J. J. Lucas, and M. J. Salkind, "Early Fatigue Damage Detection in Composite Materials," *J. Comp. Matl.* **9**, 394 (1975).
54. K. L. Reifsnider, W. W. Stinchcomb, and T. K. O'Brien, "Frequency Effects on a Stiffness-Based Fatigue Failure Criterion in Flawed Composite Specimens," in *Fatigue of Filamentary Composite Materials* (American Society for Testing and Materials, Philadelphia, PA, 1977), ASTM STP-636, K.L. Reifsnider and K.N. Lauraitis, Eds.
55. W. W. Stinchcomb, K. L. Reifsnider, and R. S. Williams, "Critical Factors for Frequency Dependent Fatigue Processes in Composite Materials," *Exptl. Mech.* **16** (9), 343 (1976).
56. H. T. Hahn and R. Y. Kim, "Fatigue Behavior of Composite Laminate," *J. Comp. Matl.* **10**, 156 (1976).
57. A. B. Schultz and D. N. Warwick, "Vibration Response: Fatigue Crack Damage in Filament-Reinforced Composites," *J. Comp. Matl.* **5**, 394 (1971).
58. R. F. Gibson and R. Plunkett, "Dynamic Mechanical Behavior of Fiber-Reinforced Composites: Measurement and Analysis," *J. Comp. Matl.* **10**, 325 (1976).
59. R. Plunkett and M. Sac, "Nonlinear Material Damping for Non-sinusoidal Strain," *J. Appl. Mech.* **45**, 883 (1978).
60. R. F. Gibson and R. Plunkett, "Forced-Vibration Technique for Measurement of Material Damping," *Exptl. Mech.* **17**, 297 (1977).
61. B. J. Lazan, "Damping Properties of Materials," in *Applied Mechanics Surveys* (Hayden Book Co., Inc., Rochelle Park, NJ, 1966), H.N. Abramson et al., Eds., pp. 703-715.
62. R. Plunkett, "Damping in Fiber Reinforced Laminated Composites at High Strain," *J. Comp. Matls.* **14**, 110 (1980).
63. T. R. Tauchert and N. N. Hsu, "Influence of Stress Upon Internal Damping in a Fiber Reinforced Composite Material," *J. Comp. Matl.* **7**, 516 (1973).
64. A. T. DiBenedetto, J. V. Gauchel, R. L. Thomas, and J. W. Barlow, "Nondestructive Determination of Fatigue Crack Damage in Composites during Vibration Tests," *J. Matl.* **7**, 211 (1972).
65. K. L. Reifsnider, E. G. Henneke, and W. W. Stinchcomb, "The Mechanics of Vibrothermography," in *The Mechanics of Nondestructive Testing* (Plenum Press, NY, 1980), W.W. Stinchcomb, Ed.
66. F. H. Chang, J. C. Couchman, J. R. Eisenmann, and B. G. W. Yee, "Application of a Special X-Ray Nondestructive Testing Technique for Monitoring Damage Zone Growth in Composite Laminates," in *Composite Reliability* (American Society for Testing and Materials, Philadelphia, PA, 1974), ASTM STP 580, pp. 176-190.
67. F. H. Chang, D. E. Gordon, B. T. Rodini, and R. H. McDaniel, "Real-Time Characterization of Damage Growth in Gr/Ep Laminates," *J. Comp. Matl.* **10**, 182 (1976).
68. H. T. Hahn, "Fracture Behavior of Composite Laminates," *Proc. Intern. Conf. Fracture Mechs. and Tech., Hong Kong, March 21-25, 1977, Vol. 1, pp. 285-296*.
69. R. E. Rowlands and I. M. Daniel, "Application of Holography to Anisotropic Composite Plates," *Exptl. Mech.* **12**, No. 2, 75 (1972).
70. R. J. Iversen, R. D. Schultz, and R. G. Arnold, "Holographic Testing Techniques," Army Weapons Command, Rock Island, IL, AD-726369, June 1971.
71. R. K. Erf, J. P. Waters, R. M. Gagosz, F. Michael, and G. Whitney, "Nondestructive Holographic Techniques for Structures Inspection," United Aircraft Research Laboratories, East Hartford, CT, AD-757510 (1972); Wright Patterson Air Force Base, OH, AFML-TR-72-20-H (1972).

72. K. Grunewald, W. Fritzsche, A.V. Harnier, and E. Roth, "NDT of Plastics by Means of Holographic Interferometry," *Polymer Engr. Sci.* **15**, 16 (1975).
73. D. Post, "Optical Interference for Deformation Measurements—Classical, Holographic, and Moiré Interferometry," in *Mechanics of Nondestructive Testing* (Plenum Press, NY, 1980), W.W. Stinchcomb, Ed.
74. C. E. Knight Jr., "Orthotropic Photo Elastic Analysis of Residual Stresses in Filament-Wound Rings," *Exptl. Mech.* **12**, 107 (1972).
75. W. H. Peters III, W. F. Ranson III, W. F. Swinson, and R. Tucker, "Shear Stress Distributions in Composite Models with Flaws," Engineering Experiment Station, Auburn University, AL, AD-782957 (1974).
76. D. G. Beghaus and R. W. Aderholdt, "Photoelastic Analysis of Interlaminar Matrix Stresses in Fibrous Composites Models," *Exptl. Mech.* **15**, 11 409 (1975).
77. B. W. Maxfield, D. M. Boyd, S. V. Kulkarni, and A. J. Schwarber, *Nondestructive Inspection and Evaluation of Composite-Material Flywheels*, Lawrence Livermore National Laboratory, Livermore, CA, UCRL-53264 (1982), Vol. 1.