

ARMY RESEARCH LABORATORY



Improved Rolled Homogeneous Armor (IRHA)

R. Brian Leavy

ARL-CR-285

March 1996

prepared by

Dynamic Science, Inc.
P.O. Box N
Aberdeen, MD 21001

under contract

DAAD05-90-D-7049

APPROVED FOR PUBLIC RELEASE; DISTRIBUTION IS UNLIMITED.

19960401 030

DTIC QUALITY INSPECTED 1

NOTICES

Destroy this report when it is no longer needed. DO NOT return it to the originator.

Additional copies of this report may be obtained from the National Technical Information Service, U.S. Department of Commerce, 5285 Port Royal Road, Springfield, VA 22161.

The findings of this report are not to be construed as an official Department of the Army position, unless so designated by other authorized documents.

The use of trade names or manufacturers' names in this report does not constitute indorsement of any commercial product.

REPORT DOCUMENTATION PAGE

Form Approved
OMB No. 0704-0188

Public reporting burden for this collection of information is estimated to average 1 hour per response, including the time for reviewing instructions, searching existing data sources, gathering and maintaining the data needed, and completing and reviewing the collection of information. Send comments regarding this burden estimate or any other aspect of this collection of information, including suggestions for reducing this burden, to Washington Headquarters Services, Directorate for Information Operations and Reports, 1215 Jefferson Davis Highway, Suite 1204, Arlington, VA 22202-4302, and to the Office of Management and Budget, Paperwork Reduction Project (0704-0188), Washington, DC 20503.

1. AGENCY USE ONLY (Leave blank)	2. REPORT DATE March 1996	3. REPORT TYPE AND DATES COVERED Final, Jan-Dec 94	
4. TITLE AND SUBTITLE Improved Rolled Homogeneous Armor (IRHA)		5. FUNDING NUMBERS C: DAAD05-90-D-7049	
6. AUTHOR(S) R. Brian Leavy			
7. PERFORMING ORGANIZATION NAME(S) AND ADDRESS(ES) Dynamic Science, Inc. P.O. Box N Aberdeen, MD 21001		8. PERFORMING ORGANIZATION REPORT NUMBER 	
9. SPONSORING/MONITORING AGENCY NAME(S) AND ADDRESS(ES) U.S. Army Research Laboratory ATIN: AMSRL-WT-TA Aberdeen Proving Ground, MD 21005-5066		10. SPONSORING/MONITORING AGENCY REPORT NUMBER ARL-CR-285	
11. SUPPLEMENTARY NOTES Point of contact for this report is Dr. William Gillich, U.S. Army Research Laboratory, Aberdeen Proving Ground, MD 21005-5066			
12a. DISTRIBUTION/AVAILABILITY STATEMENT Approved for public release; distribution is unlimited.		12b. DISTRIBUTION CODE 	
13. ABSTRACT (Maximum 200 words) <p>This report describes tests conducted on an enhanced conventional armor steel. The improved rolled homogeneous armor (IRHA) steel was designed to be harder than conventional rolled homogeneous armor (RHA), but maintain the same weight and weldability as RHA. This was accomplished through optimizing the alloy chemistry and heat treatment of the IRHA. The material was tested against a penetrator with a length-to-diameter aspect ratio of 5—a tungsten alloy slug fired from a 105-mm bore diameter gun. Standard RHA, high-hard, and some experimental harder steels were also tested for comparison with the IRHA results.</p> <p>The ballistic data of the materials tested was compared to semi-empirical calculations of the performance based on target hardness. Two separate types of IRHA were examined. The heat treatment and tempering temperatures produced two different IRHA hardnesses. A temper of 985 or 425° F resulted in an armor hardness of Rockwell C Scale 41 (Rc 41) or the harder Rc 47, respectively. Standard RHA has a hardness in the Rc 27–34 range, with the RHA used in this program being Rc 34. Tests performed utilized semi-infinite as well as finite laminate block targets. Penetration and breakout effects were analyzed to determine the overall ballistic efficiency of the IRHA.</p>			
14. SUBJECT TERMS improved rolled homogeneous armor, RHA, steel, hardness		15. NUMBER OF PAGES 28	
		16. PRICE CODE 	
17. SECURITY CLASSIFICATION OF REPORT UNCLASSIFIED	18. SECURITY CLASSIFICATION OF THIS PAGE UNCLASSIFIED	19. SECURITY CLASSIFICATION OF ABSTRACT UNCLASSIFIED	20. LIMITATION OF ABSTRACT UL

INTENTIONALLY LEFT BLANK.

ACKNOWLEDGMENTS

The author would like to thank Edward J. Rapacki, Jr., of the Armor Mechanics Branch for his help and guidance throughout this program. The program would not have been possible without the materials provided by Dr. Joseph Prifti of the Materials Directorate. I would also like to acknowledge the work of the Transonic Range crew; their effort was above and beyond the call of duty. Finally, thanks go to the Target Assembly Facility crew for their construction effort and help in analysis of the targets.

INTENTIONALLY LEFT BLANK.

TABLE OF CONTENTS

	<u>Page</u>
ACKNOWLEDGMENTS	iii
LIST OF FIGURES	vii
LIST OF TABLES	vii
1. OBJECTIVE	1
2. PROCEDURE	1
2.1 Launch System	1
2.2 Range Setup	3
2.3 Target Configurations	4
3. MATERIALS	5
4. TEST DESCRIPTION	7
5. RESULTS	8
6. CONCLUSIONS	16
7. REFERENCES	19
BIBLIOGRAPHY	21
APPENDIX: TEST DATA	23
DISTRIBUTION LIST	27

INTENTIONALLY LEFT BLANK.

LIST OF FIGURES

<u>Figure</u>		<u>Page</u>
1.	Launch package configuration	2
2.	Propellant weight and corresponding velocity	3
3.	Cartridge case and primer configuration	3
4.	Range setup and instrumentation	4
5.	Semi-infinite (SI) target setup	6
6.	Finite target setup	6
7.	Penetration curve over entire velocity regime	10
8.	Penetration curve in region of testing	10
9.	Experimental and calculated b-values for penetration	12
10.	Semi-infinite (SI) penetration data for all tested materials	12
11.	Free surface bulge vs. web thickness relation	13
12.	Breakout for armor steels	13
13.	Residual x-ray of Rc 41 IRHA steel	14
14.	Residual x-ray of Rc 47 IRHA steel	15

LIST OF TABLES

<u>Table</u>		<u>Page</u>
1.	Chemical Composition of Steels	7
2.	Summary Table of Individual Shot Information	8
3.	Armor Performance of IRHA Steel	16

INTENTIONALLY LEFT BLANK.

1. OBJECTIVE

The mainstay material of the U.S. armor design world, rolled homogeneous armor (RHA) steel, has been used in a wide variety of applications. RHA has seen relatively few technological advances since its introduction. The Improved Rolled Homogeneous Armor (IRHA) Program introduces an increase in hardness compared to the old RHA, while maintaining the weight and weldability of the steel.

The weight of an armored vehicle is a big developmental concern. A constant battle is waged between the need for increased ballistic protection and the associated increase in weight or space. The IRHA steel would increase the protection of the vehicle, with no increase in weight or space compared to conventional RHA. Maintaining weldability is another concern facing the armor designer. If the steel is weldable, it can be substituted into existing steel armor vehicle structures with relative ease.

The purpose of this program was to determine the hardness effects of steel on ballistic performance against kinetic energy (KE) penetrators. The IRHA was compared to the conventional RHA steel to reference the performance. In addition to these steels, a few samples of the Swedish-made Armox 600 steels were made available and were included in this testing program to compare the varying hardness effects.

2. PROCEDURE

2.1 Launch System. The gun system used for this armor test utilized a 105-mm smoothbore gun, which was an M68 chamber cannon with the standard length barrel. The gun was placed on an M198 towed mount.

The launch package is illustrated in Figure 1. The penetrator used for this program was a right-circular cylinder, weighing 555 g, with a length of 100 mm and a diameter of 20 mm. This corresponds to a length-to-diameter (L/D) ratio of 5. The slug, or short penetrator, was made of a Teledyne Firth Sterling X-21C swaged and strain-aged tungsten sintered alloy. The X21C penetrator composition is 93% tungsten, 3.46% nickel, 2.05% cobalt, and 1.44% iron. Hardness values for each projectile used were taken to determine the effects of penetrator hardness on performance. A typical density for this material is 17.70 g/cm³. The average hardness for the projectiles was Rockwell C Scale (Rc) 46.

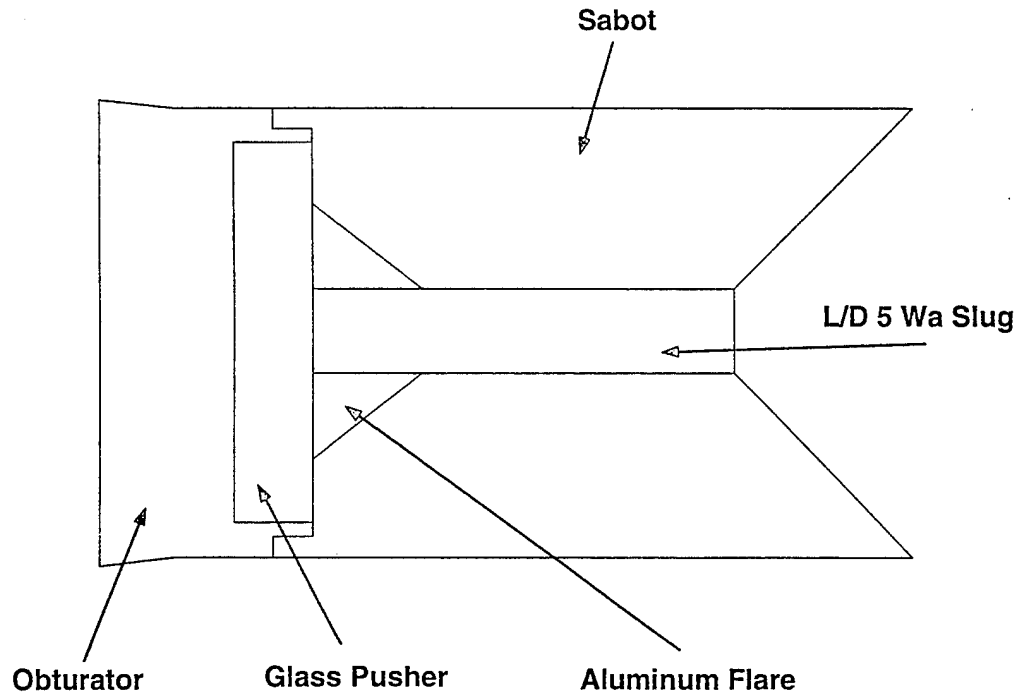

Figure 1. Launch package configuration.

To stabilize the penetrator in flight, an aluminum flare secured with a heat-treated steel pin was attached to the end of the penetrator. The obturator and sabot were made of polypropylux. They consisted of right-circular cylinders machined to fit the 105-mm smoothbore gun used in the tests. The obturator had a slight taper to better seal the push-launched package. The sabot used was an interlocking four-petal configuration. The pusher plate was an 88.9-mm-diameter, 19-mm-thick disc made from Pyrex glass.

M30 propellant, along with an M80A1 primer, was used for propulsion. The size of a typical grain was 10.102 mm, with a diameter of 4.341 mm. The nominal web size of the propellant was 0.805 mm (0.0317 in), with seven perforations per grain. The propellant charge weight varied for each shot, depending on the desired striking velocity (Figure 2). An M115B1 105-mm steel cartridge case was used to contain the propellant and primer. For the smaller charge weights, oilcard was wrapped inside the case to reduce the usable volume (Figure 3). This resulted in a minimized grain motion during flamespread, and allowed for fairly repeatable results.

L/D 5 Wa Slug, 105mm, M30 propellant, 0.0317" Web

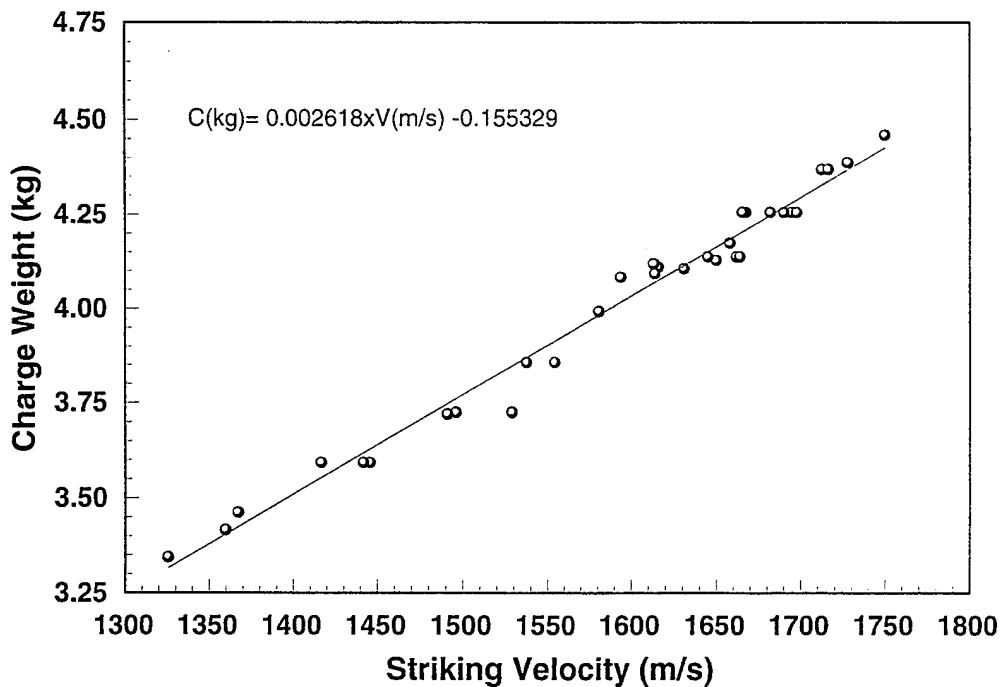

Figure 2. Propellant weight and corresponding velocity.

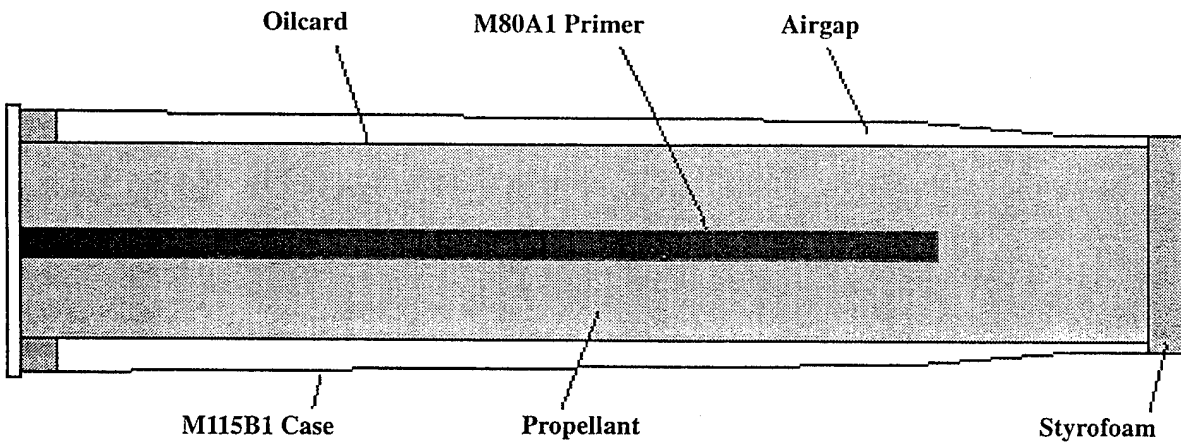

Figure 3. Cartridge case and primer configuration.

2.2 Range Setup. The 105-mm smoothbore gun was located 111.6 ft (34.02 m) away from the target. Two M11 pressure gauges were used during each shot to determine the breech pressure for a given charge weight. A stripper plate was placed 24.69 m away from the gun to ensure no pieces of the discarding

sabot went down range. After the stripper plate, three breakscreens were used to determine velocity and trigger the striking x-ray heads. The x-ray setup consisted of standard 150-kV, orthogonal plane, dual-flash x-ray heads triggered by breakscreens. Time delays based on expected striking velocities were calculated. Two striking x-rays placed 481 mm apart were used for each shot. For the residual x-rays, two x-ray heads 305 mm apart were triggered by a breakscreen on the rear face of the target. From the x-ray images produced on film, striking and residual velocities were calculated, and information about the flight of the projectile before and after the target was recorded (Figure 4).

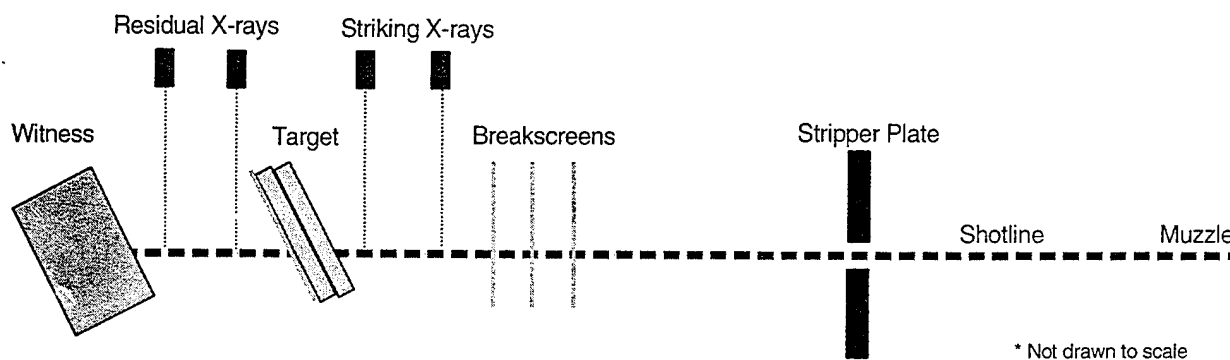

Figure 4. Range setup and instrumentation.

2.3 Target Configurations. A variety of different hardness steels were examined in this program. Steel armors have a nominal mass density of 7.85 g/cm^3 . The RHA laminate blocks tested were 457 mm wide \times 457 mm long \times 63.5 mm thick. The RHA used was slightly harder than typical, with a Brinell Hardness Number (BHN) of 321 and an Rc hardness of 34. (Most hardness measurements were taken as BHN and converted to Rc. To alleviate confusion, all subsequent hardness references use the Rc scale.)

Another material tested was the Swedish-made Armox 600 steel provided by Svenskt Stal Oxelsund. This steel had an Rc hardness of 55. The Armox plates were the only plates tested that were not 457 mm wide. The plates used were only 254 mm \times 254 mm wide and 40 mm thick.

A sampling of high-hard armor (HHA) steel was also examined. The HHA steel plates had an Rc hardness of 53. The HHA steel used was the typical production HHA used for armor applications.

As for the IRHA, two different hardnesses were examined. Steel hardnesses of Rc 41 and Rc 47 were looked at as an eventual replacement for RHA. The objective of this program was to compare the IRHA

steels with a variety of different hardness steels to determine the penetration performance and other penetration characteristics of the steel.

Both semi-infinite (SI) and finite targets were used to investigate the penetration and perforation characteristics of the tested materials. The SI targets consisted of enough material that, when the slug penetration was complete, the rear of the target was not affected. For this program, the SI targets were three 450-mm-square \times 63.5-mm-thick plates stacked at 30° obliquity from vertical (Figure 5). The total line-of-sight (LOS) thickness of the target, determined by looking horizontally along the shot line, was 220 mm. The higher hardness steel targets were the exception, with 95.3-mm LOS of HHA plates and 73.3 mm of RHA, for a LOS thickness of 168.6 mm. The Armox steel targets consisted of three of the smaller 250-mm-wide \times 40-mm-thick plates stacked at the 30° obliquity.

For each material tested, a number of SI shots were taken. If possible, two shots were fired at a lower velocity, followed by two at a higher velocity. This information gave a statistically reliable indication of the penetration characteristics throughout a wide velocity range. The finite target configurations were based on information gathered from the SI data.

For the finite targets, a baseline RHA target was shot at the limit velocity. For each hardness of the IRHA, a minimum of two shots were fired at different velocities, determined by the empirical equations based on the SI data. All of the finite targets consisted of a 73.32-mm LOS backplate with another plate in front, a 305-mm airgap and then a 117-mm witness plate made of RHA. The finite targets and the witness plates were all oriented 30° from vertical to the plate normal (60° from the horizontal shot line). See Figure 6 for an example of the finite target configuration.

3. MATERIALS

The IRHA steels were heat-treated differently to obtain two distinct hardnesses. Table 1 lists the typical chemical composition for each of the steels. The IRHA has a 0.26 weight percentage of carbon. By comparison, HHA plates have a 0.30 carbon weight percentage, and standard RHA is in the 0.25% range. Maintaining the carbon content between 0.24–0.26% ensured weldability. The nickel, along with molybdenum and chromium, content was raised to increase hardenability.

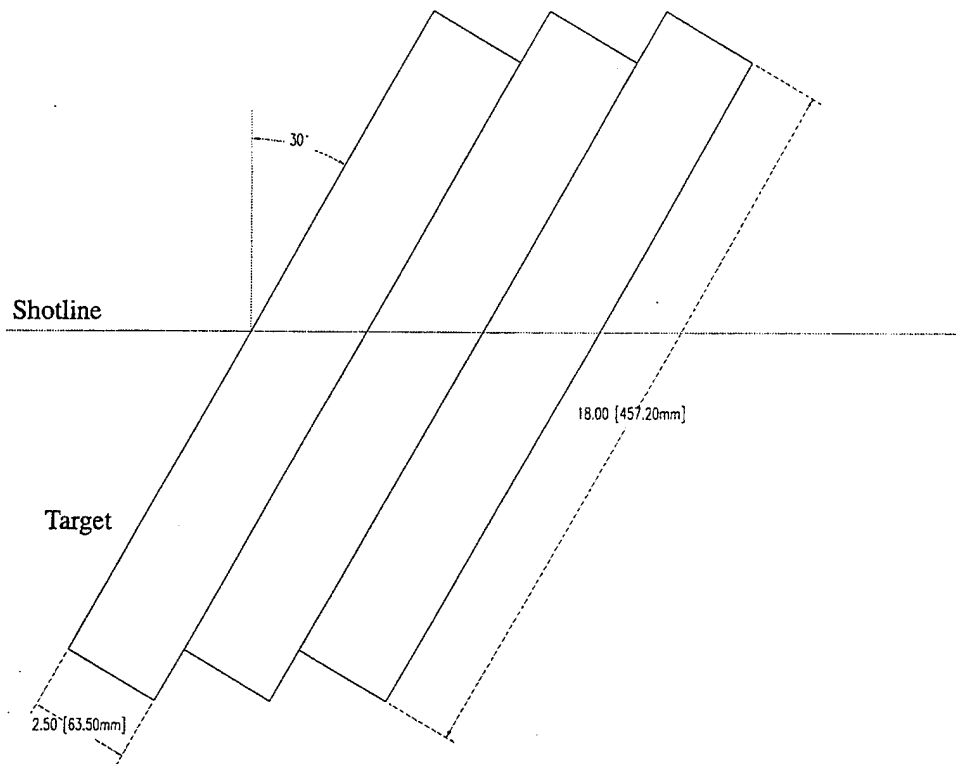

Figure 5. Semi-infinite (SI) target setup.

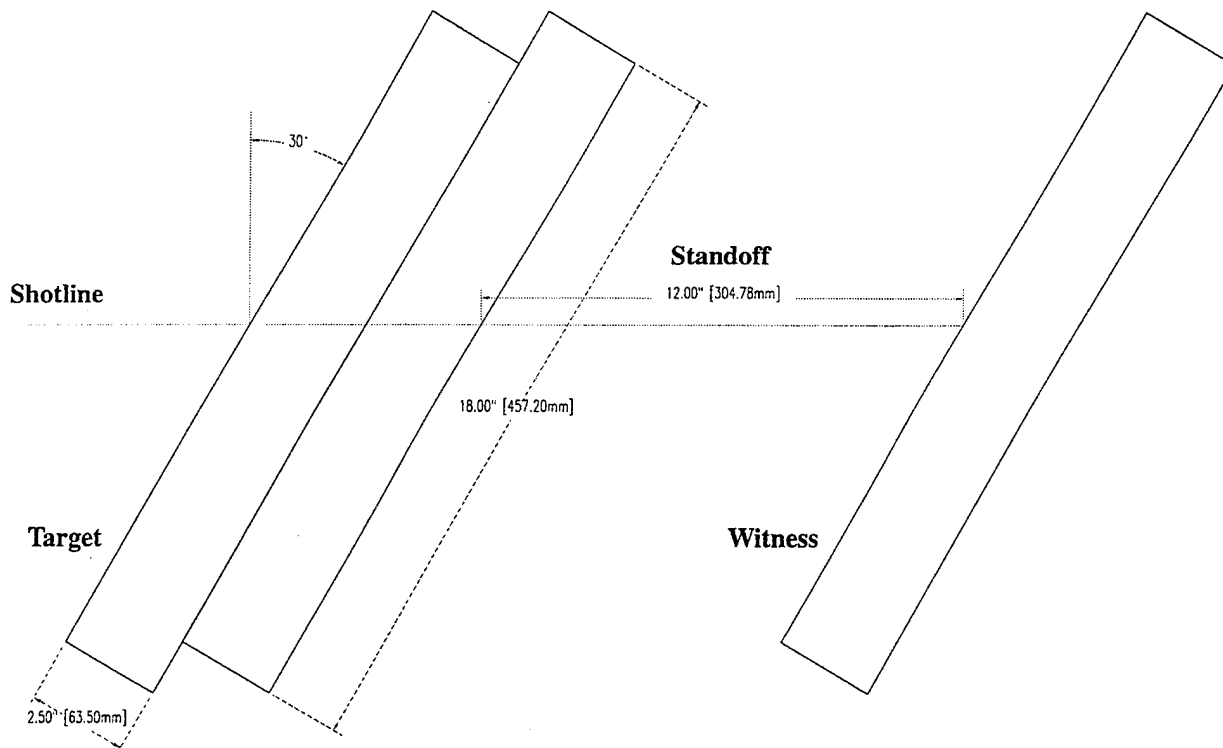

Figure 6. Finite target setup.

Table 1. Chemical Composition of Steels

Specification	C	Ni	Cr	Mo	Mn	Si	P	S
RHA	0.25	2.25	1.35	0.25	0.25	0.23	0.010	0.003
IRHA	0.26	3.25	1.45	0.55	0.40	0.40	0.009	0.002
HHA	0.30	1.10	0.60	0.50	0.90	0.40	0.010	0.005
Armox 600	0.47	3.00	1.00	0.70	1.00	0.25	0.010	0.005

The IRHA plates were reheat-treated in the following manner to obtain their new characteristics. The plates were normalized to 1,700° F, then air cooled. Next, they were austenitized at 1,625° F and water quenched. Finally, the IRHA plates were tempered either at 425° F for the Rc 47 or 985° F for the Rc 41 hardness (Prifti 1994). The exceptions to this process were the two Rc 41 targets that were from only a single heat-treated lot.

The Armox 600 plates were an add-on to the program. They provided data in the very high hardness regime with an Rc 55 hardness. A summary of the chemical compositions of the different steels is included in Table 1.

4. TEST DESCRIPTION

The testing started with the SI target shots. Two RHA baselines were performed to compare with the IRHA and to test all the range components. Next, three shots were completed with the very hard Armox steels. Following the Armox tests, four shots were done with each hardness of the IRHA. Finally, four shots were done on the HHA steel targets.

The second portion of the test dealt with the finite targets. One finite RHA baseline was taken. Next came two shots at the Rc 41 IRHA and two shots at the Rc 47 finite (F) targets. Afterwards, two shots were done with an Rc 47 front plate and an Rc 41 rear plate as a possible optimum configuration for the IRHA. Finally, two more shots were completed with monolithic hardness Rc 47 IRHA.

5. RESULTS

The complete test results are shown in the Appendix by shot number. Table 2 is a summary of useful information.

Table 2. Summary Table of Individual Shot Information

Shot No.	Target Type	Hardness (Rc)	Velocity (m/s)	P Theory (mm)	P Actual (mm)	Breakout (mm)
1094	SI RHA	34	1,360	91.61	95.12	—
1095	SI RHA	34	1,614	125.61	121.16	—
1096	SI Armox	55	1,326	56.82	59.83	—
1097	SI Armox	55	1,750	110.81	101.22	—
1098	SI Armox	55	1,631	96.72	98.18	—
1099	SI IRHA	41	1,417	85.52	89.51	—
1100	SI IRHA	41	1,446	89.53	88.43	—
1101	SI IRHA	41	1,695	121.19	121.25	—
1102	SI IRHA	41	1,698	121.56	112.95	—
1103	SI IRHA	47	1,529	90.11	88.46	—
1104	SI IRHA	47	1,496	85.79	86.87	—
1105	SI IRHA	47	1,712	112.78	108.61	—
1106	SI IRHA	47	1,716	113.23	107.20	—
1107	SI HHA	53	1,367	64.71	81.16	—
1108	SI HHA	53	1,367	64.68	76.79	—
1109	SI HHA	53	1,682	105.35	112.58	—
1110	SI HHA	53	1,667	103.60	111.89	—
1111	SI IRHA ^a	41	1,442	88.99	89.66	—
1112	SI IRHA ^a	41	1,665	117.77	116.14	—
1113	F RHA	34	1,662	131.32	129.51	17.76
1114	F IRHA	41	1,554	104.20	125.91	21.95
1115	F IRHA	41	1,491	95.69	123.85	28.16
1116	F IRHA	47	1,614	100.97	122.73	21.79
1117	F IRHA	47	1,538	91.23	117.85	26.56
1118	F IRHA	47,41	1,645	119.24	111.89	—
1119	F IRHA	47,41	1,728	128.31	121.63	25.63
1127	F IRHA	47	1,664	107.05	100.60	—
1128	F IRHA	47	1,690	110.15	106.41	—

NOTE: SI = semi-infinite, F = finite.

^a Single heat-treated IRHA plate used.

The shot numbers are a listing of the data in chronological order, as a reference point for organizing the data. RHA, HHA, IRHA, and Arnox targets were tested. Columns 2 and 3 show the target material and its measured hardness for each shot. The striking velocity was the velocity of the projectile at target impact, determined from the x-ray film. The theoretical penetration was calculated based on hardness, and will be discussed in more detail. The actual penetration, breakout, and theoretical penetration were all calculated in LOS millimeters along the shot line.

For all the different steels, a high- and low-velocity group was shot to get more information about the performance over a wide velocity regime. The shots fell well within the trends of previous work done with RHA (Enderlein 1991). A modified version of the Lanz-Odermatt (1992) analytical model for predicting penetration based on the hardness of materials was used to predict the performance of the IRHA shots. The KE penetration is modeled as an exponential of the form

$$(P/L) = ae^{-\left(\frac{b}{v}\right)^2} \quad (1)$$

Where P is the SI penetration in LOS mm, normalized by the length of the penetrator L, v is the velocity in kilometers per second (km/s), and a and b are coefficients. The b value is determined by the hardness of the target material. The relation of Brinell Hardness to the b value was given by:

$$b = \sqrt[5]{\frac{BHN}{BHN_0}} \times b_0 \quad (2)$$

The b value used in equation 1 is a function of the fifth root of the ratio between the target hardness and a reference RHA hardness, BHN_0 multiplied by the b_0 value experimentally derived for RHA (Rapacki 1994). For typical RHA with an Rc 27 hardness (BHN 269), the b_0 value is 1.3676. This number was used to determine all the subsequent penetration curves for the assortment of hardnesses. Figure 7 shows a typical penetration curve calculated over the entire velocity regime using the Lanz-Odermatt based penetration equations. Figure 8 zooms in on the velocity range of interest. In this figure, the Rc 41 hardness IRHA values are plotted. Based on the hardness, the b value of 1.525 was calculated and used to develop a general curve of penetration performance. The SI and finite data are plotted along with the theoretical penetration curve. In this graph, the Rc 41 data also included the single heat-treated lot to compare with the rest of the IRHA.

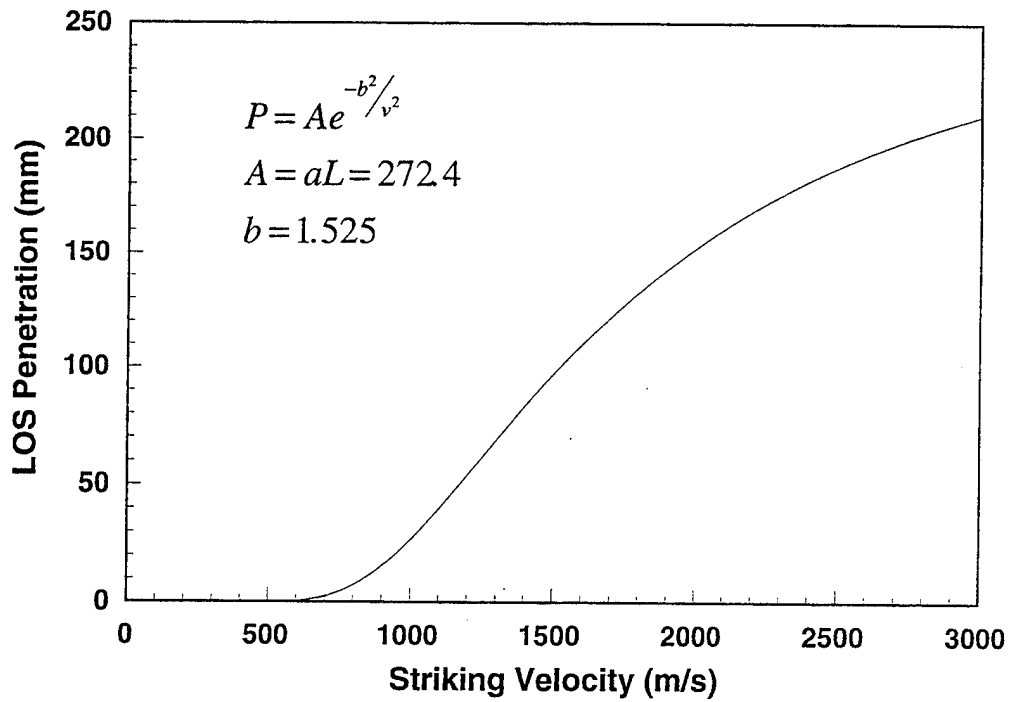

Figure 7. Penetration curve over entire velocity regime.

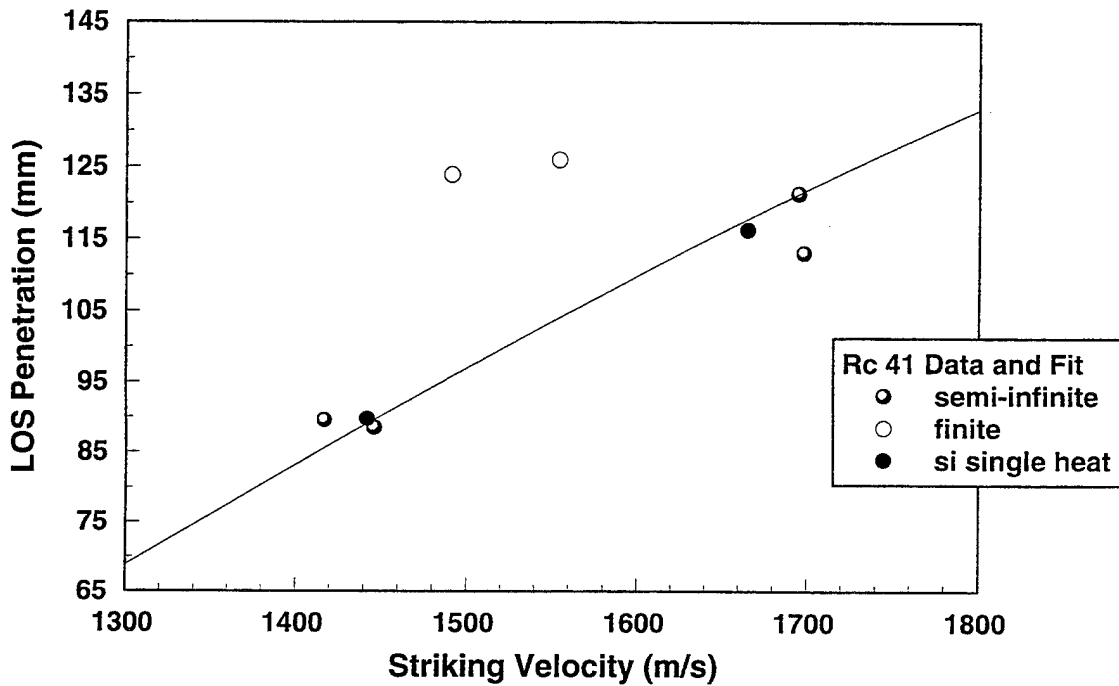

Figure 8. Penetration curve in region of testing.

From the initial values for RHA, the remaining b values for the different hardness materials were calculated. These values were compared to the calculated A and b values from the SI data (see Figure 9). The results of the SI data appear in Figure 10. A linear fit was used to better visualize the hardness results. The two higher velocity HHA shots penetrated into the RHA portion of the target. To compensate, the penetration was corrected to approximate monolithic Rc 53 HHA results by taking the inverse of the space effectiveness factor. All the other tests were strictly monolithic material. The HHA tests, although higher hardness than both the IRHA types, fell between the two IRHA hardnesses in performance. This could be due to the differing chemical composition of HHA. The fits are roughly parallel to one another, the separation illustrating the hardness based deviation.

Once the SI characteristics for each material were determined, the appropriate velocities were chosen for the finite targets, so that information would be gathered about the limit velocity for each type of steel. The V_{50} limiting velocity is the velocity for a target in which it is perforated 50% of the time for a given threat. The finite targets differ from SI because of bulging and breakout. Bulging occurs in a finite target as the penetrator nears the rear surface, but does not perforate the target. In the post mortem examination of the targets, the normal web size, or the remaining thickness of material in the target, as well as the bulge height and thickness were recorded. Examining the bulge gives information about the material behavior in a large deformation regime. Figure 11 shows the free surface bulge information as related to the web thickness. In general, the greater the bulge, the smaller the web, or material left to penetrate.

As an overmatched penetrator defeats a finite target, a portion of the rear of the target plugs out. This plug is an example of breakout, or the target material that does not assist in the defeat of a threat. The breakout for each material is calculated by subtracting the Lanz-Odermatt semi-infinite penetration fit from the total finite penetration. The breakouts for some of the varying hardness steels are illustrated in Figure 12. The measurements of target breakout are presented in millimeters along the normal to the target surface. Generally, as the hardness of a material increases, so does the breakout. Figures 13 and 14 illustrate the typical breakout witnessed by the residual x-rays for the two types of IRHA armor. One can see the large debris size, as well as the penetrator exiting the rear of the target. Two images were flashed on one piece of film to determine the residual velocities of the penetrator exiting the target. As the velocity of the penetrator approached the limit velocity, or velocity where it would break through the target only half of the time, the exit path becomes more normal to the rear target face. This can be seen by comparing the two examples shown and noticing the corresponding velocities. Figure 13 is the finite Rc 41 IRHA target shot at 1,491 m/s, with about a 28-mm breakout. In Figure 14, the IRHA target had an Rc 47 hardness, was fired at 1,538 m/s, and had approximately 27 mm of breakout.

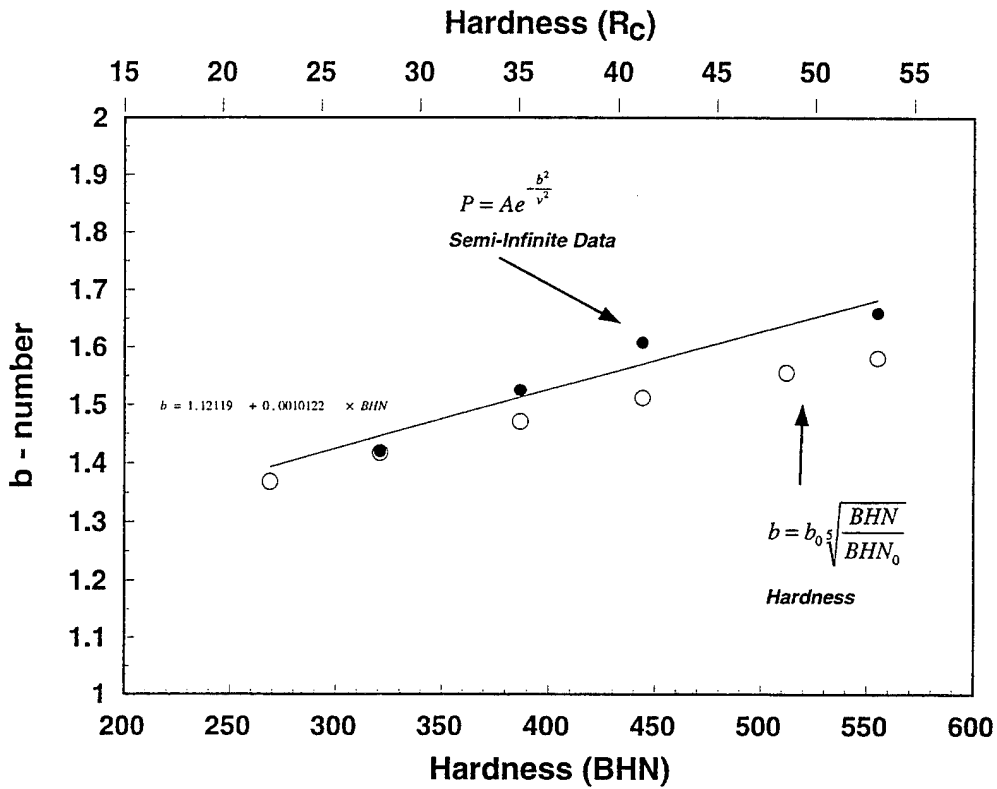

Figure 9. Experimental and calculated b-values for penetration.

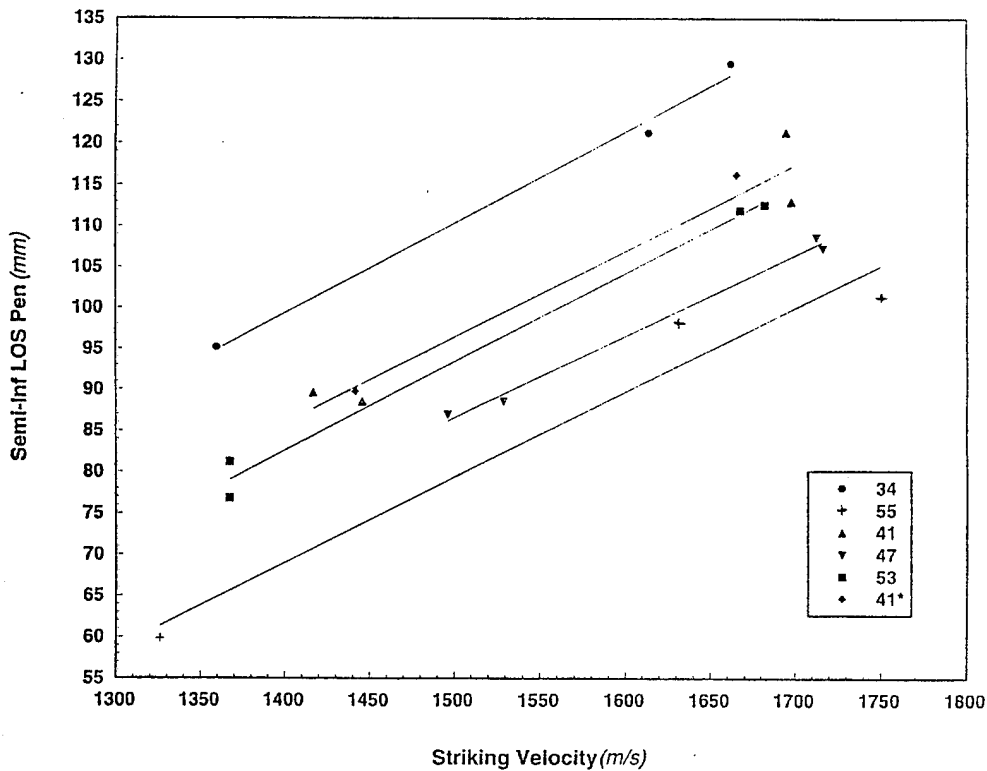

Figure 10. Semi-infinite (SI) penetration data for all tested materials.

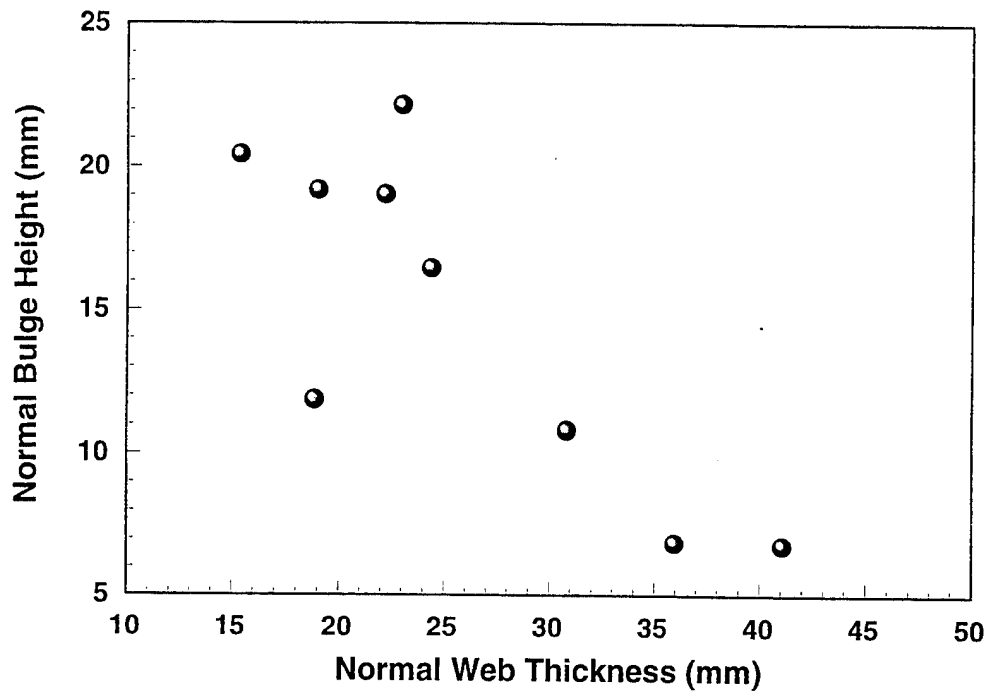

Figure 11. Free surface bulge vs. web thickness relation.

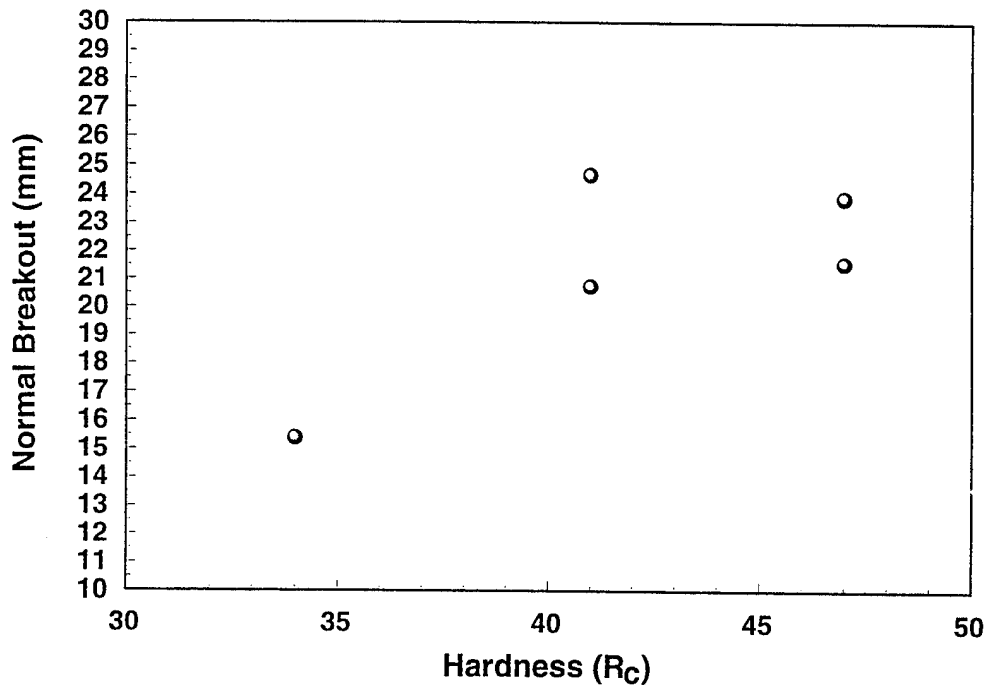

Figure 12. Breakout for armor steels.

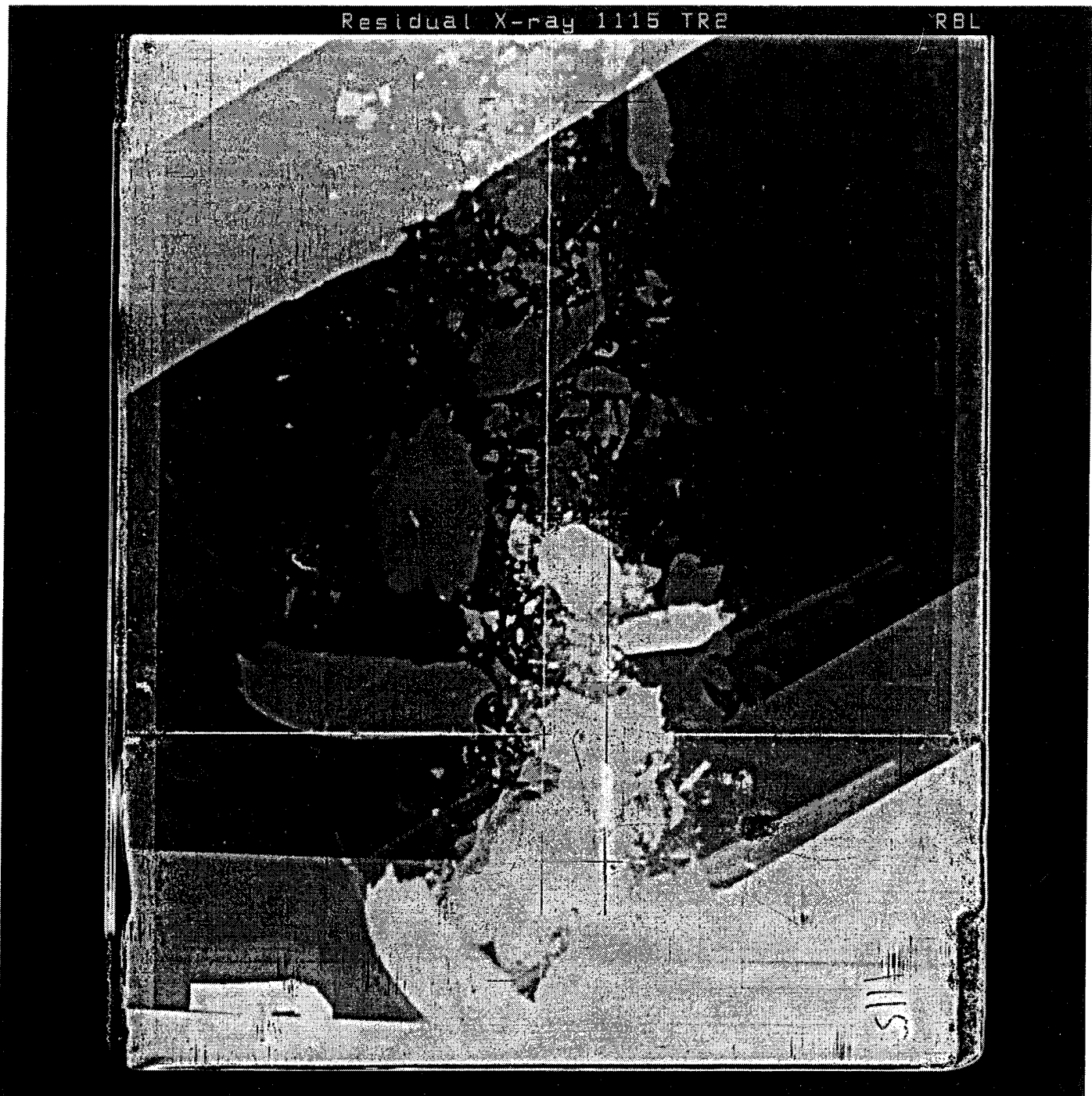

Figure 13. Residual x-ray of Rc 41 IRHA steel.

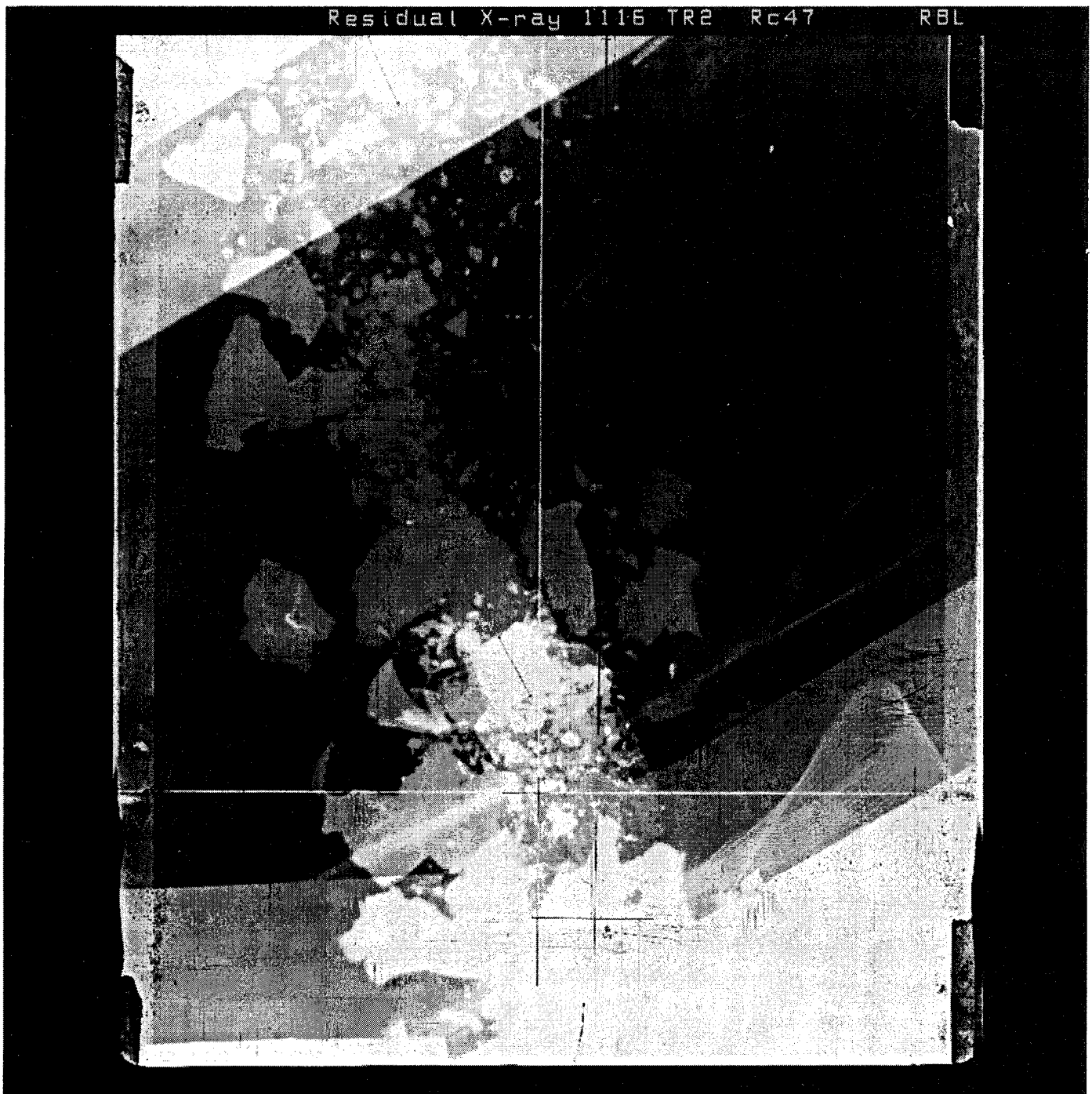

Figure 14. Residual x-ray of Rc 47 IRHA steel.

In computing the effectiveness of the IRHA steels, they were compared to typical RHA with an Rc 27 hardness. The variable Δ relates the relative penetration capabilities of the IRHA steels to RHA.

$$\Delta = RHA - P + BO \quad (3)$$

In this equation, Δ is equal to the calculated RHA penetration, minus the IRHA finite penetration, plus the breakout of the IRHA. All values are computed in LOS millimeters. The values were computed for the average velocity of all the shots taken in this program, which was 1,506 m/s. These numbers were then used to calculate the ballistic efficiency for the finite and SI IRHA tests shown in Table 3.

Table 3. Armor Performance of IRHA Steel

Hardness (Rc)	Δ (mm)	E_f	E_{si}
41	3.2	1.03	1.22
47	13.6	1.14	1.37

The ballistic efficiency is calculated from the space effectiveness factor, E_s . Since the density for IRHA and RHA are the same, the mass effectiveness is equal to the space effectiveness. The value of E_s is the depth of penetration of a given target, divided by the reference RHA penetration for the same velocity. E_f and E_{si} are the corresponding space effectiveness factors for the finite and SI tests, respectively.

Both of the IRHA hardness materials performed better than typical RHA. The difference between the SI and finite results can be attributed to breakout and bulging in the finite targets. The higher hardness Rc 47 IRHA appears to have been the most ballistically efficient of the two in any configuration.

6. CONCLUSIONS

The IRHA performed better than the standard RHA against the L/D 5 KE penetrators tested. Although the higher hardness IRHA had more breakout, it was still ballistically superior to the old RHA. The Rc 47 IRHA performed even better than the Rc 41 hardness material. Greater penetration resistance along with approximately the same breakout as the Rc 41 IRHA was a characteristic of the harder IRHA.

Surprisingly, HHA steel with an Rc 53 hardness fell between the two IRHA steels in performance. The Armox steel with RC 55 hardness effectively resisted penetration but shattered extensively due to the high hardness and small size plates used for testing. All in all, the IRHA steels, with Rc 41 and Rc 47 hardnesses, showed increased ballistic efficiencies over conventional RHA, with no accompanying increase in weight or space for enhanced performance.

INTENTIONALLY LEFT BLANK.

7. REFERENCES

- Enderlein, M. W. "Armor Backpack Effectiveness Against Penetrators at Ordnance Velocity." BRL-MR-3939, U.S. Army Ballistic Research Laboratory, Aberdeen Proving Ground, MD, October 1991.
- Lanz, W., and W. Odermatt. "Penetration Limits of Conventional Solid Propellant Gas/Kinetic Energy Projectiles." Proceedings of the 13th International Symposium on Ballistics, vol. 3, Stockholm, Sweden, 1-3 June 1992.
- Prifti, J. Private conversations. U.S. Army Research Laboratory, Watertown, MA, 1994.
- Rapacki, E. J. Private conversations. U.S. Army Research Laboratory, Aberdeen Proving Ground, MD, 1994.

INTENTIONALLY LEFT BLANK.

BIBLIOGRAPHY

- Carmichael, C. Kent's Mechanical Engineers' Handbook. New York: John Wiley & Sons, Inc., 12th Edition, 1969.
- Leslie, W. C. The Physical Metallurgy of Steels. Hemisphere Publishing Co., New York, NY, 1981.
- McGannon, H. E. The Making, Shaping and Treating of Steel. 9th Edition, United States Steel, Pittsburgh, PA, 1971.
- Rapacki, E. J., et al. "Armor Steel Hardness Influence on Kinetic Energy Penetrators." Proceedings of the 15th International Symposium on Ballistics, Jerusalem, Israel, 21-24 May 1995.

INTENTIONALLY LEFT BLANK.

**APPENDIX:
TEST DATA**

INTENTIONALLY LEFT BLANK.

IRHA - Improved RHA tests

R. Brian Leavy

Obliquity: 30

Plate size: 18x18", (10x10" Armoxx)

Shot#	Target#	Proj#	Obt	Type	Configuration, Rc, Ser#	Chrg Wt (lbs)	Br Press (kpsi)	Striking Velocity (m/s) Expect	Bkscrn	X-ray	Residual
1094	1	1	V	RHA Semi-Infinite	3 ea 2.5, 34, RHA	7.53	18.8	1375	1383	1360	
1095	2	2	M	RHA Semi-Infinite	3 ea 2.5, 34, RHA	9.08	29.6	1625	1614		
1096	A1	22	H	Armoxx SI	2 ea 40mm, 55, 600	7.37	17.8	1350	1339	1326	
1097	A2	23	O	Armoxx SI	3 ea 40mm, 55, 600	9.83	39.1	1745	1776	1750	
1098	A3	24	N	Armoxx SI	3 ea 40mm, 55, 600	9.05	32.2	1620		1631	
1099	3	3	Y	IRHA Semi-Infinite	3 ea 2.5, 40.4, 97581B	7.92	21.5	1425	1427	1417	
1100	4	4	Z	IRHA Semi-Infinite	3 ea 2.5, 40.4, 97581B	7.92	22.9	1425	1430	1446	
1101	5	5	L	IRHA Semi-Infinite	3 ea 2.5, 40.4, 97581B	9.38	35.4	1675	1730	1695	
1102	6	6	I	IRHA Semi-Infinite	3 ea 2.5, 40.4, 97581B	9.38	35.4	1675	1737	1698	
1103	7	7	S	IRHA Semi-Infinite	3 ea 2.5, 46.6, 97845 (A)	8.21	26.4	1475	1528	1529	
1104	8	8	T	IRHA Semi-Infinite	3 ea 2.5, 46.6, 97845 (A)	8.21	24.3	1475	1500	1496	
1105	9	9	A	IRHA Semi-Infinite	3 ea 2.5, 46.6, 97845 (A)	9.63	36.7	1725	1713	1712	
1106	10	10	B	IRHA Semi-Infinite	3 ea 2.5, 46.6, 97845 (A)	9.63	36.8	1725	1730	1716	
1107	11	11	W	HH Semi-Infinite	1 ea 1.5, 2 ea 1.75, HH; 1 ea 2.5, RHA	7.63	18.8	1375	1365	1367	
1108	12	12	X	HH Semi-Infinite	1 ea 1.5, 2 ea 1.75, HH; 1 ea 2.5, RHA	7.63	19.0	1375	1366	1367	
1109	13	13	D	HH Semi-Infinite	1 ea 1.5, 2 ea 1.75, HH; 1 ea 2.5, RHA	9.38	34.2	1675	1674	1662	
1110	14	14	C	HH Semi-Infinite	1 ea 1.5, 2 ea 1.75, HH; 1 ea 2.5, RHA	9.38	33.8	1675	1649	1667	
1111	15	15	P	SIRHA Semi-Infinite	2 ea 2.5, 40.8, 94982A*, 1 ea 2.5 RHA	7.92	21.4	1425	1449	1442	
1112	16	16	E	SIRHA Semi-Infinite	2 ea 2.5, 40.8, 94982A*, 1 ea 2.5 RHA	9.38	33.5	1650	1643	1665	
1113	17	17	G	RHA Finite	2 ea 2.5, RHA	9.12	32.7	1630	1655	1662	
1114	18	18	K	IRHA Finite	1 ea 1.5, 40.4; 1 ea 2.5, 40.4, 97581B	8.50	27.8	1529	1571	1554	1318
1115	19	19	R	IRHA Finite	1 ea 1.5, 40.4; 1 ea 2.5, 40.4, 97581B	8.20	24.1	1500	1510	1491	1244
1116	20	20	AA	IRHA Finite	1 ea 1.5, 46.6; 1 ea 2.5, 46.6, 97845A	9.02		1619	1678	1614	1366
1117	21	21	Q	IRHA Finite	1 ea 1.5, 46.6; 1 ea 2.5, 46.6, 97845A	8.50		1535	1548	1538	1189
1118	22	25	U	IRHA Finite	1 ea 2.5m 97845A, 1 ea 2.5, 97581B	9.12		1662	1651	1645	
1119	23	26	F	IRHA Finite	1 ea 2.5m 97845A, 1 ea 2.5, 97581B	9.67		1730	1728	1728	
1127	24	27	BB	IRHA Finite	2 ea 2.5, 82071A	9.12	33.4	1645	1681	1664	
1128	25	28	CC	IRHA Finite	2 ea 2.5, 82071A	9.38	35.4	1681	1710	1690	

IRHA - Improved RHA tests

R. Brian Leavy

Obliquity: 30

Plate size: 18x18", (10x10" ArmoX)

Shot#	Target#	Impact Yaw (deg)		LOS Target Thickness (mm)			LOS Penetration (mm)			Plate 3	Witness	Pen Equiv	Breakout	Total
		Tot Yaw	Orient	Plate 1	Plate 2	Plate 3	Plate 1	Plate 2	Plate 3					
1094	1	3.16	206	73.47	73.47	73.32	73.47	73.47	73.32	220.26				95.12
1095	2			73.53	73.56	73.32	73.53	73.53	73.32	220.41				121.16
1096	A1	4.80	132	46.19	46.99		46.19	46.19		93.17				59.83
1097	A2	1.11	74	47.15	47.01	47.07	47.15	47.15	7.07	141.23				101.22
1098	A3	2.13	126	46.19	47.04	47.04	46.19	46.19	4.96	140.27				98.18
1099	3	1.45	147	74.17	74.23	73.32	74.17	74.17		221.72				89.51
1100	4	4.76	139	73.32	74.14	73.32	73.32	73.32		220.79				88.43
1101	5	1.70	339	74.23	74.11	73.32	74.23	74.23		221.66				121.25
1102	6	1.11	93	73.85	73.94	73.32	73.85	73.85		221.11				112.95
1103	7	1.06	166	73.82	73.44	73.32	73.82	73.82		220.58				88.46
1104	8	1.47	154	73.56	73.56	73.32	73.56	73.56		220.44				86.87
1105	9	1.07	330	73.79	73.59	73.32	73.79	73.79		220.77				108.61
1106	10	1.16	134	73.50	73.65	73.32	73.50	73.50		220.47				107.2
1107	11	0.46	245	44.76	51.77	73.32	44.76	44.76		169.85				81.16
1108	12	1.58	100	44.76	51.80	73.32	44.76	44.76		169.88				76.79
1109	13	1.32	192	44.55	51.71	73.62	44.55	44.55		169.88				112.58
1110	14	1.70	143	44.67	51.71	73.70	44.67	44.67		170.08				111.89
1111	15	2.03	159	74.20	71.18	73.32	74.20	74.20		218.70				89.66
1112	16	1.27	192	74.14	73.82	73.32	74.14	74.14		221.28				116.14
1113	17	1.78	9	73.68	73.59		73.68	73.68		147.27		17.76		129.51
1114	18	0.95	261	43.88	73.71		43.88	43.88		117.58				125.92
1115	19	2.64	70	43.76	73.32		43.76	43.76		117.08			8.34	123.85
1116	20	1.06	63	43.99	73.50		43.99	43.99		117.49			5.24	122.73
1117	21	1.72	27	44.17	73.68		44.17	44.17		117.85			26.56	117.85
1118	22	1.18	89	73.50	74.00		73.50	73.50		147.50				111.89
1119	23	0.75	226	73.32	73.94		73.32	73.32		147.26			25.63	121.63
1127	24	2.05	138	73.94	74.09		73.94	73.94		148.03				100.60
1128	25	0.82	343	73.97	73.97		73.97	73.97		147.94				106.41

NO. OF
COPIES

ORGANIZATION

2 DEFENSE TECHNICAL INFO CTR
ATTN DTIC DDA
8725 JOHN J KINGMAN RD
STE 0944
FT BELVOIR VA 22060-6218

1 DIRECTOR
US ARMY RESEARCH LAB
ATTN AMSRL OP SD TA
2800 POWDER MILL RD
ADELPHI MD 20783-1145

3 DIRECTOR
US ARMY RESEARCH LAB
ATTN AMSRL OP SD TL
2800 POWDER MILL RD
ADELPHI MD 20783-1145

1 DIRECTOR
US ARMY RESEARCH LAB
ATTN AMSRL OP SD TP
2800 POWDER MILL RD
ADELPHI MD 20783-1145

ABERDEEN PROVING GROUND

5 DIR USARL
ATTN AMSRL OP AP L (305)

NO. OF
COPIES ORGANIZATION

2 DYNAMIC SCIENCE INC
ATTN R LEAVY
405 OAKTON WAY
ABINGDON MD 21009

ABERDEEN PROVING GROUND

6 DIR, USARL
ATTN: AMSRL-WT-TA,
 W GILLICH
 W BRUCHEY
 G BULMASH
 E RAPACKI
AMSRL-WT-TD, T FARRAND
AMSRL-MA-PD, S CHOU

USER EVALUATION SHEET/CHANGE OF ADDRESS

This Laboratory undertakes a continuing effort to improve the quality of the reports it publishes. Your comments/answers to the items/questions below will aid us in our efforts.

1. ARL Report Number ARL-CR-285 Date of Report February 1996

2. Date Report Received _____

3. Does this report satisfy a need? (Comment on purpose, related project, or other area of interest for which the report will be used.) _____

4. Specifically, how is the report being used? (Information source, design data, procedure, source of ideas, etc.) _____

5. Has the information in this report led to any quantitative savings as far as man-hours or dollars saved, operating costs avoided, or efficiencies achieved, etc? If so, please elaborate. _____

6. General Comments. What do you think should be changed to improve future reports? (Indicate changes to organization, technical content, format, etc.) _____

CURRENT ADDRESS

Organization

Name

Street or P.O. Box No.

City, State, Zip Code

7. If indicating a Change of Address or Address Correction, please provide the Current or Correct address above and the Old or Incorrect address below.

OLD ADDRESS

Organization

Name

Street or P.O. Box No.

City, State, Zip Code

(Remove this sheet, fold as indicated, tape closed, and mail.)
(DO NOT STAPLE)