

NASA Technical Memorandum 80209

Graphics and Composite Material Computer
Program Enhancements for SPAR

Gary L. Farley and Donald J. Baker

February 1980

DISTRIBUTION STATEMENT A
Approved for public release;
Distribution Unlimited

19960322 103

NASA
National Aeronautics and
Space Administration
Langley Research Center
Hampton, Virginia 23665

DEPARTMENT OF DEFENSE
PLASTICS TECHNICAL EVALUATION CENTER
AERADCOM, DOVER, N. J. 07801

PLASTEG 37496

UNCLASSIFIED

DISCLAIMER NOTICE



THIS DOCUMENT IS BEST QUALITY AVAILABLE. THE COPY FURNISHED TO DTIC CONTAINED A SIGNIFICANT NUMBER OF PAGES WHICH DO NOT REPRODUCE LEGIBLY.

GRAPHICS AND COMPOSITE MATERIAL COMPUTER
PROGRAM FOR USE WITH SPAR

BY Gary L. Farley and Donald J. Baker
Structures Laboratory, USARTL

SUMMARY

The SPAR computer software system is used for finite element structural and thermal analysis. This report contains user documentation of additional computer programs that have been developed for use in conjunction with SPAR. These programs plot digital data, simplify input for composite material section properties and compute lamina stresses and strains. Sample problems are presented including execution procedures, program input and tabulated and graphical output.

INTRODUCTION

Studies of structural configurations using finite element models yield large amounts of data which must be analyzed. Effective evaluation of these data can be enhanced by a graphical representation. This paper contains the user documentation for computer programs developed or modified to interface with the data base of the SPAR level 14 finite element computer code (reference 1). These capabilities are used in the interpretation of results and in reducing input to the composite material section properties of the SPAR computer code. These capabilities include; (1) a hidden line graphics program for plotting the deformed and undeformed finite element model; (2) a contour plotting program; and (3) a capability for the development of composite material section properties and subsequent postprocessing of lamina stresses and strains into a more convenient form. These programs are written in FORTRAN IV language for the Control Data Cyber series digital computers with the Network Operating System (NOS). The plotting program contains adequate comment statements to allow conversion to any plotting system.

SYMBOLS

X Y Z	- Coordinate system fixed in model
X ₀ Y ₀ Z ₀	- Coordinate system containing viewing planes
z	- Coordinate through the thickness
σ_x σ_y τ_{xy}	- Normal and shear stresses in the elemental reference frame
σ_1 σ_2 τ_{12}	- Normal and shear stresses in the principal material coordinate systems
ϵ_x ϵ_y γ_{xy}	- Normal and shear strains in the elemental reference frame
ϵ_1 ϵ_2 γ_{12}	- Normal and shear strains in the principal material coordinate system
E11 E22 E33 G12 G12 G23 UN12 UN13 UN23	- Three dimensional extensional and shear moduli and Poisson's ratio
RHO	- Material density
t	- Finite element thickness
h _i	- Distance from neutral axis
k	- Layer numbers

Program Capabilities

The three capabilities described in this report were developed as preprocessors or post processors to SPAR, interacting only with the SPARLA data base. By implementing these capabilities in this fashion the impact on subsequent versions of SPAR would be minimized. The necessary I/O and data handling routines employed in these capabilities are described in reference (2).

Another common feature of these capabilities is dynamic addressing of storage (DAS). By utilizing DAS all problem dependent vectors of data are stored in a single working vector in blank COMMON. This allows the user to specify only the central memory necessary to solve the problem. The working vector, blank COMMON, begins at the first word address following the loaded program and extends to the end of the available central memory as defined by the user.

The concept of element groups and types, in SPAR, can enable a user to greatly reduce the complexity of modeling and interpreting the results of a structure. In a similar fashion the three capabilities utilize this concept to allow the user to specify parts of the structure to be operated upon. This is performed by the selection of sets of element groups and types. No option exists to select specific elements within a particular group.

HIDDEN LINE REMOVAL GRAPHICS PROGRAM - HIDLIN

The hidden-line graphics program, denoted as HIDLIN, is a modification of that presented in references 3 and 4 which was an option to the general orthographic plotting program of reference 5. Plots of the deformed and undeformed finite element model in a 3-D rectangular Cartesian coordinate system are generated on a 2-D viewing plane by HIDLIN. The deformed plots are of nodal translations such as static displacements and vibration or buckling modes. Such plots are very useful in debugging complex finite element models and in visualizing the overall structural response of the model.

Comparison of figures 1 and 2 illustrates the clarity of a composite cross beam model drawn by HIDLIN versus a drawing of all elements by SPAR. The deformed plot is shown in figure 3.

Another example of the usefulness of HIDLIN is depicted in figures 4 through 7 showing the finite element model used in supersonic cruise aircraft research at NASA - Langley Research Center (ref. 6). This model consists of rods, shear webs and triangular and quadrilateral membrane and aleotropic elements. The full undeformed finite element model of the aircraft model is presented in figure 4 with figures 5 and 6 representing the undeformed and deformed HIDLIN

plots respectively. Figure 7 represents the HIDLIN drawing of just the shear webs of the model depicting the internal structure. Upon inspection of figures 1 through 7 the advantages of using HIDLIN is evident in debugging and visualizing the structural response of the finite element models.

Plots can be generated for structural models containing any combination of 1, 2 and 3-D elements. Faces of the solid elements (3-D) are internally converted by the program to triangular or quadrilateral (2-D) elements for computation purposes. In terms of SPAR nomenclature the elements the user can specify are; E21-E24, E31-E33, E41-E44, S41, S61, S81.

Graphic errors in the form of partially drawn "hidden elements" can occur during a normal execution of HIDLIN. These errors, if they occur, do not greatly detract from the overall appearance of the structure and do not reduce the program's effectiveness in debugging complex finite element models or in depicting overall structural response as seen by comparing figures 3 and 8. To eliminate these errors, the user can rotate the model a few degrees or adjust DMAG. DMAG, used in checking an element's visibility, is the parameter that controls the amount an element is reduced about its center. The causes of these errors are numerical roundoff and a limitation on the number of segments of a partially hidden element.

The additional computation required to reduce or eliminate these errors is not justifiable.

Input data.- The input data deck is shown schematically in Figure 9 and is described in detail in this section. SPAR data base SPARLA must be disc resident prior to the execution of HIDLIN.

SPARLA data.- The SPARLA data base must contain the basic structure topology prior to execution of HIDLIN.

SPARLA DATA				
<u>SET NAME</u>				<u>DESCRIPTION</u>
JLOC	BTAB	2	5	Data set containing nodal coordinates
DEFO	POSI	MASK	MASK	Data set containing nodal translations in similar format as JLOC BTAB. This data set is used in deformed plots only. This data set can be developed through use of the TRAN function in processor AUS.
DEF	E21	MASK	MASK	Data sets containing element connectivities.
	⋮			
"	E24	"	"	
"	E31	"	"	
	⋮			
"	E33	"	"	
"	E41	"	"	
	⋮			
"	E44	"	"	
"	S41	"	"	
"	S61	"	"	
"	S81	"	"	

User defined data.- User defined data includes a NAMELIST statement and data defining element type and group numbers of the plotted structure.

NAMELIST MAX.- This NAMELIST contains values to allocate storage and values specifying various program options.

<u>FORTRAN NAME</u>	<u>DEFAULT VALUE</u>	<u>DESCRIPTION</u>
IDISP	0	Deformed plot parameter 0 - undeformed plot 1 - deformed plot
NCKELE		Estimate of the total number of triangular and quadrilateral finite elements (must be equal to or greater than the actual numbers)
DSCALE	1.0	Displacement magnification factor used when IDISP=1
DELX, DELY	1.0	Origin shift factor in the scaled and rotated coordinate systems
KHORZ	1	Integer designating the horizontal axis of the viewing plane where 1= X_0 ; 2= Y_0 ; 3= Z_0
KVERT	2	Integer designating the vertical axis of the viewing plane where 1= X_0 ; 2= Y_0 ; 3= Z_0

<u>FORTTRAN NAME</u>	<u>DEFAULT VALUE</u>	<u>DESCRIPTION</u>
PHI	0.0	Angular rotation of model about its X-axis in degrees (performed third)
THETA	0.0	Angular rotation of model about Y-axis in degrees (performed second)
PSI	0.0	Angular rotation of model about its Z-axis in degrees (performed first)
PSCALE	1.0	Joint coordinate magnification factor
DMAG	.99	Reduction factor used in reducing the size of each element about its center for checking visibility of an element.

The scaling of the joint coordinates (XYZ) and deformations (DISP) and the translation of the plotting origin (DELX, DELY) is described by the following equation;

$$XYZ^{\text{plot}} = XYZ^{\text{model}} \cdot \text{PSCALE} + \text{DISP} \cdot \text{DSCALE} + \text{DEL}(X \text{ or } Y).$$

The following card(s) determine element type and group number to be considered by the program.

<u>COLUMN</u>	<u>FORTRAN VARIABLE</u>
1-5 (Right adjusted)	NGRP Element group number
6-10 "	<u>NELT</u> <u>Spar Element Type</u>
	21 E21
	22 E22
	⋮ ⋮
	44 E44
	441 S41
	661 S61
	881 S81

An estimate of the field length required to run HIDLIN is given as follows:

$$FL_{10} = 18355 + 6 * (NNOD + NCKELE)$$

where NNOD is the number of nodes and NCKELE is the sum of the triangular and quadrilateral finite elements.

Output.- The input NAMELIST MAX is printed to verify input data, followed by the length of blank common required for program execution. The third section of output is a listing of element types and group numbers that are being plotted. An example of input and output (printed and plotted) is presented in sample problem 1.

CONTOUR PLOTTING

The contour plotting capability consists of two programs which are executed sequentially. The first program, denoted as STR, extracts user designated topology and stress

information from the SPARLA library and sets up two input files for the contour plotting program, STCR. Using the input data developed by STR, STCR plots contours over the specified structure. Besides the contour levels only the border of the specified structure is drawn to reduce confusion. Three plots are generated corresponding to σ_x , σ_y , and τ_{xy} stresses. Figure 10 depicts stress contours of the upper flange of the composite cross beam structure shown in figures 1 through 3.

PREPROCESSOR FOR CONTOUR PLOTTING - STR

STR extracts stress and topology data resident in the SPARLA library and sets up two input files for the contour plotting program STCR. The user designates the element types and group numbers in specifying the desired structure. Triangular and quadrilateral membrane and aleotropic elements are considered in SPAR nomenclature as E31, E33, E41, E43 elements. All the elements in the specific groups are included in the input file for STCR.

Stresses as calculated in SPAR are oriented in the local elemental reference frame. These local reference frames can vary from element to element and must be transformed to a common reference frame. This transformation is accomplished by rotating these local stresses by the angle θ which the user must input into the SPAR material property (MATC) table.

Input data.- The input data deck is shown schematically in Figure 9 and is described in detail in this section. SPAR data base SPARLA must be disk resident prior to the execution of STR.

SPARLA data.- The SPARLA data base must contain the basic structure topology and stress information prior to execution of STR.

<u>SPARLA DATA</u> <u>SET NAME</u>	<u>DESCRIPTION</u>
JLOC BTAB 2 5	Data set containing nodal coordinates
MATC BTAB MASK MASK	Data set containing material property table
SA BTAB MASK MASK	Data set containing section property table
STRS E31 MASK MASK	Data sets containing element
" E33 " "	connectivities and stress
" E41 " "	information
" E43 " "	

User defined data.- User defined data includes a NAMELIST statement and data defining element type and group numbers of the plotted structure.

NAMELIST MAN.- This NAMELIST contains topology and stress parameters pertinent to the execution of STR. MAN also contains the appropriate NAMELIST parameters used in NAMELIST MAX of program STR.

<u>FORTRAN NAME</u>	<u>DEFAULT VALUE</u>	<u>DESCRIPTION</u>
III	1	Horizontal axis on viewing plane where 1=X, 2=Y, 3=Z are the model coordinate system
JJJ	2	Vertical axis on viewing plane where 1=X, 2=Y, 3=Z are the model coordinate system
IPOS	0	Location of stress calculation for SPAR finite elements 0 z = 0 (mid-plane) 6 z = t/2 (upper-surface) 12 z = -t/2 (lower-surface)
ICEN	0	Location of stress component (this parameter common to STR and STCR) 0 centroidal stress 1 nodal stress

The following parameters are required in this NAMELIST
and are passed to program STCR.

SCLX, SCLY	1.0	Joint coordinate scale factor
XSHFT, YSHFT	1.0	Origin shift factor
NCONT	5	Number of contour levels
ILAB	0	Contour labeling parameter 0 - No 1 - Yes
HGHT	.1	Size of contour label

<u>FORTRAN NAME</u>	<u>DEFAULT VALUE</u>	<u>DESCRIPTION</u>
ICOPT	0	Contour specification parameter 0 - program specifies contour based upon the formula $SS(J) = \frac{(I)}{NCONT+1} * (SMAX(J) - SMIN(J)) + SMIN(J)$ I=1, NCONT; J=1, 2, 3 where SS is the stress contour level and J=1, 2, 3 represents the stress component σ_x , σ_y , τ_{xy} respectively 1 - user specifies contour levels based upon the formula $SS(J) = (I-1) * DSIG(J) + SIG(J)$
SIG(J)	0.0	Starting stress contour level
DSIG(J)	0.0	Stress contour level increment
RNDOFF	1.0E-7	Roundoff error parameter used to eliminate small deviations from 0.0 level contour
ILERoy	0	Leroy plotting option 0 - No 1 - Yes

The following card(s) determine element type and group number to be considered in this program.

<u>COLUMN</u>	<u>FORTRAN VARIABLE</u>	
1-5 (Right adjusted)	NN	Element type
		<u>Spar Element</u> <u>NN</u>
		E31 31
		E33 33
		E41 41
		E43 43
6-10 (Right adjusted)	NG1	Element Group Number

The user can stack several different type and group cards to define the appropriate structure.

An estimate of the field length required to run STR is given as follows:

$$FL_{10} = 15589 + 3 * NNOD + 9 * NMAT + 43 * NSECT \\ + NNN * NEL$$

where $NNN = \begin{matrix} 9 & \text{if } ICEN = 0 \\ 16 & \phantom{\text{if } ICEN = } 1 \end{matrix}$

NNOD is the number of nodes in the model, NMAT and NSECT are the number of entries in the MATC and SA tables respectively, NEL is the number of finite elements to be plotted and ICEN defines where the stresses are computed on the elements.

Output.- The output from this program is in two forms, printed and disk or tape resident. Input NAMELIST MAN is printed to verify input data, followed by the length of blank common required for program execution. The third section of output is a listing of the element types and group numbers that are to be plotted. The disk resident output from this routine to be used in the contour plotter is formatted in card

images and located on tape 9 and tape 10. The data structure of tape 9 consists of; NAMELIST MAX, sequential ordering of joints and element connectivities. Tape 10 contains the elemental centroidal or nodal stresses (σ_x , σ_y , τ_{xy}).

CONTOUR PLOTTING PROGRAM - STCR

The contour plotting program, STCR, draws the border of the specified structure along with specified contour levels. Those contours intersecting the border can be optionally labeled corresponding to the printed output. The contour levels are tabulated in the program output. The method of drawing contours employed in STCR is analogous to that of reference 5 and will not be discussed here. Three contour plots, depicting σ_x , σ_y , and τ_{xy} , are drawn during a program execution as demonstrated in sample problem 2.

The contours depicted in figures 10a through 10c have sharp corners and small extensions which could mislead the interpretation of results by a novice user of a finite element program. These corners are a result of the stress averaging at the element nodes and calculation of the contour line segment. These contours can be made smoother by using a finer mesh of elements.

Input data.- If program STCR is executed sequentially after STR, no additional input is necessary. The following data are given to allow this program to be used alone. Tape 9

(input file) contains NAMELIST MAX, sequential ordering of joints and element connectivities while tape 10 contains element centroidal or nodal stresses ($\sigma_x, \sigma_y, \tau_{xy}$).

NAMELIST MAX.- This NAMELIST contains all the parameters necessary to control the contour plotting.

<u>FORTTRAN</u> <u>NAME</u>	<u>DEFAULT</u> <u>VALUE</u>	<u>DESCRIPTION</u>
--------------------------------	--------------------------------	--------------------

NNOD		Number of nodes
------	--	-----------------

NEL		Number of elements
-----	--	--------------------

See NAMELIST MAX of program STR for description of the following: SCLX, SCLY, XSHFT, YSHFT, NCONT, ILAB, HGHT, ICOPT, SIG(3), DSIG(3), RNDOFF, ILEROY.

- Sequential ordering of nodal coordinates

X_c, Y_c ; (NNOD cards) (2F10.4)

- Element Connectivities (NEL cards) (4I5)

- Element centroidal or nodal stresses

if ICEN=0 centroidal stresses

$\sigma_x, \sigma_y, \tau_{xy}$ (3F10.4)

if ICEN=1 nodal stresses

σ_x (4F10.4)

σ_y (4F10.4)

τ_{xy} (4F10.4)

An estimate of the field length required to run STCR is given as follows:

$$FL_{10} = 18088 + 6 * NNOD + 4 * NEL$$

where NNOD and NEL are the number of nodes and finite elements respectively.

Output.- NAMELIST MAX is printed to verify input. The length of blank common is indicated. The contour number and its associated value is listed. A typical plotted output is shown in sample problem 2.

COMPOSITE LAMINATE CAPABILITY

The composite laminate program consists of two programs; SAT, which is used to calculate the section property table (SA data set), and program STST for the determination of lamina stresses and strains in the elemental and principal material directions. The input of composite laminate section properties into SPAR is possible by direct input of the laminate stiffness coefficient matrix or by ply-by-ply specification of the lamina stiffness matrix. Either method requires the user to execute additional programs, separate from SPAR, to generate this input data. In the execution of program SAT the user defines the necessary orthotropic material properties and the appropriate stacking sequence for each section while the program performs all necessary calculations for the SPAR SA table entries.

The stress recovery in SPAR has two forms. For all elements with section types other than LAMINATE the laminate stress resultants or average laminate stresses are computed while the LAMINATE section type provides for the calculation of stresses on a ply-by-ply basis only. Neither of these allow for the direct determination of strains in the elemental

or principal material reference direction. In addition to the SPAR generated stress data the user can have program STST calculate stresses and strains in the elemental and principal material directions on a ply-by-ply basis. This information can be optionally directed to a file in a format consistent with input for the contour plotting program STCR.

SHELL SECTION PROPERTIES PROGRAM - SAT

The SAT program generates shell section properties, SA table entries, applicable to composite materials. Besides the SA table data set, developed by SAT, a data set containing constituent section properties, denoted as ARMY COMP (NLAY) 0, is stored in the SPARLA library. These data sets in addition to the stress resultants computed by SPAR are used by program STST in computing lamina stresses and strains of the appropriate elements. The SA tables generated by SAT are applicable to the following SA sections; isotropic, membrane, plate, uncoupled and coupled.

The user specifies the constituent material properties to be used in developing all the different section properties. Each different section is defined with respect to ply orientation, lamina thickness and constituent materials. Sign convention and consistency with the mathematical formulation of SPAR is maintained. Figure 11 depicts sign convention and typical laminate construction.

Input data.- The input data deck is shown schematically in figure 12 and is described in detail in this section. SPAR library SPARLA must be disk resident prior to the execution of SAT.

Comment card.- One card required to identify the data deck.

NAMELIST MAX.- This NAMELIST sets up the required number of cards to be read later for different section properties. Note, there are no default values in this namelist.

<u>FORTTRAN VARIABLE</u>	<u>DESCRIPTION</u>
NSECT	Number of different section properties to be developed
NLAY	Maximum number of layers in a section
NMAT	Number of different material properties to be input

NAMELIST PROP.- This NAMELIST contains the material identification number and its associated properties.

<u>FORTTRAN VARIABLE</u>	<u>DESCRIPTION</u>
IMAT	Material property identification (number not to exceed NMAT)
E11, E22, E33, G12, G13, G23, UN12, UN13, UN23	Three dimensional material properties
RHO	Material density

NAMELIST SECT.- This NAMELIST contains the section topology information to be read in NSECT times.

<u>FORTTRAN VARIABLE</u>	<u>DESCRIPTION</u>
ILAY	Number of layers in section
ISPARM	SPAR material number corresponding to MATC table entry
ISPTYP	SPAR section type
	<u>ISPTYP</u> <u>SPAR SECTION TYPE</u>
	1 membrane
	2 plate
	3 uncoupled
	4 coupled
	3 isotropic
ZSHFT	Neutral axis shift

The following layer identification card(s) to be read ILAY times for each section.

<u>COLUMN</u>	<u>FORTTRAN VARIABLE</u>	<u>DESCRIPTION</u>
1-10	THETA(I)	lamina rotation angle, relative to the elemental and material coordinate systems, refer to figure 11(b)
11-20	T(I)	lamina thickness
21-25 (Right M(I) adjusted)		lamina material number (IMAT)

SPAR stress recovery cards

<u>FORTTRAN VARIABLE</u>	<u>DESCRIPTION</u>
F(I, J)	SPAR stress recovery parameter I=1, 2, 3; J=1, 2, 3, 4, 5, 6 (18 entries) Format (8E10.3)

An estimate of the field length required to run SAT is given as follows:

$$FL_{10} = 18867 + 37 * NMAT + (12 * NLAY + 140) * NSECT + NLAY$$

where NMAT is the number of different materials, NLAY is the maximum number of layers in any laminate and NSECT is the number of sections (SA table entries).

Output.- All input NAMELISTS are printed along with the [ABD] matrices (a 6 x 6 laminate coefficient stiffness matrix) and their inverses for each section (SA table entry). An example of input and output is presented in sample problem 3.

STRESS-STRAIN CALCULATION PROGRAM - STST

Program STST determines lamina stresses and strains in the elemental and principal material directions. A contour plotting option is available to the user in the creation of a stress or strain file applicable to program STCR. As was the case in programs HIDLIN and STR the user defines the structure of interest by specifying group numbers and element types. All the elements within such a specification would have their lamina stresses and strains computed. Successive specifications can be defined to establish the desired structure.

Input data.- The input data deck is shown schematically in Figure 9 and is described in detail in this section. SPAR library SPARLA must be disc resident prior to execution with data set ARMY COMP (NLAY) 0, generated by program SAT, resident.

SPARLA data.- The SPARLA data base must contain the constituent material properties for each section, as generated by SAT, and stress information prior to the execution of STST.

<u>SPARLA DATA SET NAME</u>	<u>DESCRIPTION</u>
ARMY COMP (NLAY) 0	Data set containing the constituent material properties for each section
STRS E31 MASK MASK " E33 " " " E41 " " " E43 " "	Data set containing element stress information
MATC BTAB MASK MASK	Data set containing material property table

User defined data.- User defined data includes a NAMELIST statement and data defining element type and group numbers of the plotted structure.

NAMELIST MAX.-

<u>FORTTRAN VARIABLE</u>	<u>DEFAULT</u>	<u>DESCRIPTION</u>
IPLAY	1	Layer number for plotting
IGRPH	0	Plotting parameter
		No = 0
		Yes = 1 $\equiv \sigma_x, \sigma_y, \tau_{xy}$
		2 $\equiv \epsilon_x, \epsilon_y, \gamma_{xy}$

<u>FORTTRAN VARIABLE</u>	<u>DEFAULT</u>	<u>DESCRIPTION</u>
		$3 \equiv \sigma_1, \sigma_2, \tau_{12}$
		$4 \equiv \epsilon_1, \epsilon_2, \gamma_{12}$
PER	.5	Ratio defining where the stresses, through the thickness, in each layer are computed. PER is relative to the lower edge of each lamina. NOTE: PER = .5 is mid-surface

The following card(s) indicate the element type group number to be considered by the program.

<u>COLUMN</u>	<u>FORTTRAN VARIABLE</u>	<u>DESCRIPTION</u>
1-5 (Right adjusted)	NELE	Element type
		<u>NELE</u> <u>SPAR ELEMENT TYPE</u>
		31 E31
		33 E33
		41 E41
		43 E43
6-10 (Right adjusted)	NGRP	Element group number

An estimate of the field length required to run STST is given as follows:

$$FL_{10} = 24249 + 24 * NMAT + NSECT * (11 * NLAY + 44)$$

where NMAT is the number of different materials, NSECT is the number of sections (SA table entries) and NLAY is the maximum number of layers in any laminate.

Output.- The input NAMELIST MAX is printed out along with information pertaining to laminate construction generated by SAT. For each element of the specified group and type the laminate strains and curvatures and lamina stresses and strains in the elemental and principal material directions are printed. Stresses or strains for designated layers are printed on tape 10 for use in conjunction with program STCR. An example of input and output is presented in the sample problem 4.

Concluding Remarks

The computer codes described in this report have been found to reduce hand manipulation of data and improve visualization of results. The HIDLIN program proved beneficial in debugging complex finite element models and visualizing the overall response of the model. The composite material programs SAT and STST greatly reduce the manipulation of input data and extend the computational capability of SPAR. The contour plotting program used in conjunction with SPAR or program STST significantly adds to the stress plotting capabilities currently available in SPAR.

REFERENCES

1. Whetstone, W. D.: SPAR Structural Analysis System Reference Manual - System Level II. Volume I - Program Execution. NASA CR-145096-1, 1977.
2. Giles, Gary L.; and Haftka, Raphael T.: SPAR Data Handling Utilities. NASA TM 78701, 1978.
3. Farley, Gary L.: Interactive Structural Optimization With Strength and Flutter Constraints. M.S. Thesis, The George Washington University, 1976.
4. Farley, Gary L.: Three Dimension Hidden Line Plotting Algorithm with Contour Capabilities. VPI-E-77-9, 1977.
5. Giles, Gary L.: Digital Computer Programs for Generating Oblique Orthographic Projections and Contour Plots. NASA TN D-7797, 1975.
6. Giles, Gary L.; and McCullers, L. A.: Simultaneous Calculation of Aircraft Design Loads and Structural Member Sizes. AIAA Preprint No. 75-965, August 1975.

SAMPLE PROBLEMS

Problem 1

This example illustrates the input, output, and typical plot from program HIDLIN. The Calcomp plotter with Leroy pen was utilized to plot figure 2. A listing of input data cards follows:

```
$MAX PHT=-45,THETA=+45.,PSI=45.,NCKELE=450,DISP=0,OSCALE=100.,ILEROY=1$END
1 43
2 43
3 43
4 43
5 43
6 43
7 43
8 43
9 43
10 43
16 43
11 43
12 43
13 43
14 43
15 43
17 43
18 43
1 33
2 33
```

The output listing for Problem 1 follows.

*MAX

IDISP = 1,
NCKELE = 450,
DSCALE = .1E+03,
DFLX = .1E+01,
DFLY = .1E+01,
KHORZ = 1,
KVERT = 2,
PHI = -.45E+02,
THETA = .45E+02,
PST = .45E+02,
PSCALE = .1E+01,
DMAG = .99E+00,
ILEROY = 1,

*END

STORAGE REQUIRED IN COMMON (DEC.) 3910
STORAGE REQUIRED IN COMMON (OCT.)00007506

GROUP NUMBER= 1
ELEMENT TYPE= 43
GROUP NUMBER= 2
ELEMENT TYPE= 43
GROUP NUMBER= 3
ELEMENT TYPE= 43
GROUP NUMBER= 4
ELEMENT TYPE= 43
GROUP NUMBER= 5
ELEMENT TYPE= 43
GROUP NUMBER= 6
ELEMENT TYPE= 43
GROUP NUMBER= 1
ELEMENT TYPE= 33
GROUP NUMBER= 2

Problem 2

This example illustrates the input and output data from programs STR and STCR. A Calcomp plotter with Leroy pen was utilized to plot (figure 10) the stress contours on the upper flange of a composite cross beam. A listing of input data cards follows:

```
.....  
$MAN III=1,JJJ=3,NCONT=20,ILAB=1,ICOPT=1,SIG(1)=-4500,SIG(2)=-4000,ILFROY=1,  
SIG(3)=-1000,DSIG(1)=500,DSIG(2)=500,DSIG(3)=200,ICEN=0,SCLX=.5,SCLY=.5 $END  
.....  
43 6  
43 7  
43 8  
43 14  
33 2  
.....
```

The output listing for program STR of Sample Problem 2...
is shown below.

```
START
IJI      = 1.
JJI      = 3.
SCLX     = .5E+00.
SCLY     = .5E+00.
XSHFT    = .1E+01.
YSHFT    = .1E+01.
ICEN     = 0.
NCONT    = 20.
IPOS     = 0.
ILAB     = 1.
HGBT     = .1E+00.
ICOPT    = 1.
SIG      = -.45E+04. -.4E+04. -.1E+04.
USIG     = .5E+03. .5E+03. .2E+03.
ILEE0Y   = 1.
RNDOFF   = .1E-06.

SEND
STORAGE USED IN COMMON + 7 OR 16 X NEI (DEC.)      2319
STORAGE USED IN COMMON + 7 OR 20 X NEI (OCT.)00004417

ELEMENT TYPE= 43
GROUP NUMBER= 6
ELEMENT TYPE= 43
GROUP NUMBER= 7
ELEMENT TYPE= 43
GROUP NUMBER= 8
ELEMENT TYPE= 43
GROUP NUMBER= 14
ELEMENT TYPE= 33
```

The output listing for program STCR of Sample Problem 2 is shown below.

```

*MAX
ANOD  = 403.
NEI   = 76.
ICP  = 0.
XSHFT = .1E+01.
YSHFT = .1E+01.
SCIX  = .5E+00.
SCLY  = .5E+00.
NCONT = 20.
ILAB  = 1.
NGHT  = .1E+00.
SIG   = -.45E+04, -.4E+04, -.1E+04.
ESTG  = .5E+03, .5E+03, .2E+03.
ICGRT = 1.
TEPROY = 1.
RNDOFF = .1E-06.
*END
STORAGE USED IN COMMON (DEC.)      2723
STORAGE USED IN COMMON (OCT.)00005243

```

MAX-MIN STRESS VALUES

```

.647E+03 -.748E+04
.882E+04 -.583E+03
.678E+03 -.678E+03

```

STRESS	1	CONTOUR NUMBER	1	VALUE	-.4500000E+04
STRESS	2	CONTOUR NUMBER	2	VALUE	-.4000000E+04
STRESS	3	CONTOUR NUMBER	3	VALUE	-.6000000E+04
STRESS	3	CONTOUR NUMBER	4	VALUE	-.4000000E+03

Problem 3

This example illustrates the input and output from program SAT which computes the SA Table entries for SPARLA.

A listing of input data cards follows:

```

SAMPLE CASE FOR PROGRAM SAT
*MAX ISFCT=2,NLAY=6,NMAT=2 $END
$PROP IMAT=1,F11=17.F6,E22=2.E6,G12=.52E6,UNI12=.38 $END
*PROP IMAT=2,E11=9.F6,E22=9.E6,G12=.6E6,UNI12=.3 $END
$SECT ILAY=4,ISPARM=1,ISPTYP=4 $END
-----
45. .0455 2
-45. .0455 2
-45. .0455 2
45. .0455 2
1.0 1.0 1.0 0.0 0.0 0.0 1.0 1.0
1.0 0.0 0.0 0.0 1.0 1.0 1.0 0.0
0.0 0.0
-----
$SECT ILAY=5,ISPARM=3,ISPTYP=4 $END
0.0 .033 1
45. .026 2
0.0 .044 1
45. .026 2
0.0 .033 1
1.0 1.0 1.0 0.0 0.0 0.0 1.0 1.0
1.0 0.0 0.0 0.0 1.0 1.0 1.0 0.0
0.0 0.0

```

The output listing for program SAT of Sample Problem 3

is shown below.

```

*****
NASET = 2.
NLAY = 6.
NMAT = 2.
SEED
STORAGE USED IN COMMON (DEC.) = 405.
STORAGE USED IN COMMON (OCT.)00000771
    
```

MAT	F11	F22	F33	G12	G13	G23
1	.170E+02	.200E+07	0.	.520E+06	0.	0.
2	.000E+07	.000E+07	0.	.400E+06	0.	0.

```

*****
ISPECT = 4.
ISPADE = 1.
ISPTYP = 4.
TS-ET = 0.0.
SEED
    
```

THETA	THICKNESS	MAT
.450E+02	.455E-01	2
-.450E+02	.455E-01	2
-.450E+02	.455E-01	2
.450E+02	.455E-01	2

```

STEPWISE DEFORMATION PARAMETERS (E)
.100E+01 .100E+01 .100E+01 0. 0. .100E+01 .100E+01 .100E+01
.100E+01 0. 0. .100E+01 .100E+01 .100E+01 0.
0.
MATRIX OF SECTION 1
.107000E+07 .106000E+07 0. .814007E-09 .6004010E-08 -.827106E-24
.106000E+07 .127000E+07 0. .694491E-09 .814007E-09 .277106E-24
.630000E+06 .827106E-24 .827106E-24 -.407453E-09
.42073E-09 .42073E-09 .827106E-24 .353101E+04 .292416E+04 -.842101E-11
.814007E-09 .827106E-24 .292416E+04 .353101E+04 .842101E-11
.827106E-24 .407453E-09 .842101E-11 .442101E-11 .1739010E+04
SECTION 1
.11401 .100000E+01 .402157E-18 .392020E-18 -.210406E-32
.141000E-18 .210406E-32
.410000E-18 .719000E-18
INVERSE OF AED MAT-EX FOR SECTION 2
.400000E+01 .327310E-18 .400000E-18 .1025400E-18 .640613E-17
.327310E-18 .101255E-05 .109766E-19 .631413E-19 .400600E-19 .29.
.400000E-18 .109766E-19 .421595E-05 .806602E-33 .278404E-32 .145213E-17
.100000E-18 .421413E-19 .806602E-33 .194404E-03 .113610E-03 .121402E-17
.640613E-19 .806602E-33 .278404E-32 .113610E-03 .101417E-02 .442245E-17
.421413E-19 .297361E-22 .145213E-17 .121502E-17 .442245E-17 .2630017E-02
    
```

```

ECHO OF SA TABLE
.400000E+01 .100000E+01 0. .250000E-05 -.207570E-05 .250000E-05 -.190884E-48 .100000E-48
.100000E-05 .402157E-18 .392020E-18 .101255E-05 .109766E-19 .631413E-19 .400600E-19 .29.
.750000E-03 .806602E-03 .121402E-17 .210406E-32 .371000E-18 .803321E-17 .403321E-17 .475039E-03
.100000E+01 .100000E+01 .100000E+01 .100000E+01 0. 0. 0. .100000E+01 .100000E+01 .100000E+01
0. 0. 0. .400000E+01 .300000E+01 0. .496977E-06 .3273310E-06
.101255E-05 .4039140E-20 .109755E-19 .421595E-05 .1025400E-18 .631413E-19 .8066020E-33 .1964496E-03
.400613E-19 .400600E-19 .278404E-32 .113610E-03 .101517E-02 .923021E-33 .2973610E-32 .145213E-17
.121502E-17 .442245E-17 .2630017E-02 .100000E+01 .100000E+01 .100000E+01 .100000E+01 0.
0. 0. .100000E+01 .100000E+01 .100000E+01 0. 0. 0. 0.
.100000E+01 .100000E+01 .100000E+01 0. 0. 0. 0.
    
```

The output listing for program STST of Sample Problem 4

is shown below.

S MAX
 IPLAY = 1.
 IGPPII = 0.
 PER = 0.0.
 SEND

NUMBER OF MATERIALS = 3
 MAXIMUM NUMBER OF LAYERS/SECTION = 20
 NUMBER OF SA TABLE ENTRIES = 23

STORAGE USED IN COMMON (DEC.) 6145
 STORAGE USED IN COMMON (OCT.) 00014001

GROUP NUMBER	1	ELEMENT TYPE	EP1	EP2	EP3	EP4	EP5	EP6	EP7	EP8	EP9	EP10	EP11	EP12	EP13
ID LN	SGX	EPX	SG1	EP1	SGY	EPY	SG2	EP2	TAUXY	GMXY	TAU12	GM12			
MID-PLANE STRAINS															
1 1	-57.	.00021	-10777.	-.00063	-10777.	-.00063	-57.	.00021	314.	.00060	-314.	-.00060			
1 2	3726.	.00024	3726.	.00024	-1133.	-.00065	-1133.	-.00065	310.	.00060	310.	.00060			
1 3	98.	.00031	-11598.	-.00068	-11598.	-.00068	98.	.00031	303.	.00058	-303.	-.00058			
1 4	5341.	.00034	5341.	.00034	-1165.	-.00070	-1165.	-.00070	299.	.00057	299.	.00057			
1 5	201.	.00037	-12145.	-.00072	-12145.	-.00072	201.	.00037	295.	.00057	-295.	-.00057			
1 6	6955.	.00044	6955.	.00044	-1196.	-.00075	-1196.	-.00075	287.	.00055	287.	.00055			
1 7	356.	.00047	-12965.	-.00077	-12965.	-.00077	356.	.00047	283.	.00054	-283.	-.00054			
1 8	8032.	.00050	8032.	.00050	-1217.	-.00079	-1217.	-.00079	279.	.00054	279.	.00054			
1 9	511.	.00056	-13785.	-.00082	-13785.	-.00082	511.	.00056	272.	.00052	-272.	-.00052			
1 10	-709.	.00060	212.	.00039	-2431.	-.00084	-3551.	-.00064	1782.	.00051	861.	-.00143			
1 11	-197.	.00073	495.	.00039	-2163.	-.00091	495.	.00039	1675.	.00048	-983.	.00164			
1 12	315.	.00086	-2458.	-.00091	-1895.	-.00098	778.	.00039	1568.	.00045	1105.	.00184			
1 13	828.	.00099	1661.	.00039	-1627.	-.00105	-1862.	-.00045	1461.	.00042	-1227.	-.00204			
MID-PLANE STRAINS															
2 1	-57.	.00021	-10777.	-.00063	-10777.	-.00063	-57.	.00021	314.	.00060	314.	.00060			
2 2	3726.	.00024	3726.	.00024	-1133.	-.00065	-1133.	-.00065	310.	.00060	-310.	-.00060			
2 3	98.	.00031	-11598.	-.00068	-11598.	-.00068	98.	.00031	303.	.00058	303.	.00058			
2 4	5341.	.00034	5341.	.00034	-1165.	-.00070	-1165.	-.00070	299.	.00057	-299.	-.00057			
2 5	201.	.00037	-12145.	-.00072	-12145.	-.00072	201.	.00037	295.	.00057	295.	.00057			
2 6	6955.	.00044	6955.	.00044	-1196.	-.00075	-1196.	-.00075	287.	.00055	-287.	-.00055			
2 7	356.	.00047	-12965.	-.00077	-12965.	-.00077	356.	.00047	283.	.00054	283.	.00054			
2 8	8032.	.00050	8032.	.00050	-1217.	-.00079	-1217.	-.00079	279.	.00054	-279.	-.00054			
2 9	511.	.00056	-13785.	-.00082	-13785.	-.00082	511.	.00056	272.	.00052	272.	.00052			
2 10	-709.	.00060	212.	.00039	-2431.	-.00084	-3551.	-.00064	1782.	.00051	861.	-.00143			
2 11	-197.	.00073	495.	.00039	-2163.	-.00091	495.	.00039	1675.	.00048	-983.	.00164			
2 12	315.	.00086	-2458.	-.00091	-1895.	-.00098	778.	.00039	1568.	.00045	1105.	.00184			
2 13	828.	.00099	1661.	.00039	-1627.	-.00105	-1862.	-.00045	1461.	.00042	-1227.	-.00204			
MID-PLANE STRAINS															
14 1	5740.	-.00017	-11854.	-.00014	-2470.	.00049	1626.	.00188	-6704.	-.00186	10.	.00002			
14 2	-7593.	-.00022	17428.	.00014	11524.	.00052	706.	-.00151	-8494.	.00163	6.	.00001			
14 3	5192.	-.00022	17428.	.00014	11524.	.00052	706.	-.00151	-8494.	.00163	55.	.00010			
14 4	-7593.	-.00022	-11854.	-.00014	-2470.	.00049	1377.	.00166	-6181.	-.00151	103.	.00020			
14 5	134.	-.00029	421.	.00023	2298.	.00048	2012.	-.00004	-648.	-.00145	879.	-.00163			
14 6	-1260.	-.00039	1492.	-.00001	1709.	.00043	-992.	.00005	-376.	-.00121	853.	.00142			
14 7	-2553.	-.00049	972.	.00002	1119.	.00038	-2406.	-.00013	-105.	-.00097	727.	.00121			
14 8	-3896.	-.00059	-3819.	-.00031	530.	.00033	453.	.00005	166.	-.00073	-601.	-.00100			
MID-PLANE STRAINS															
15 1	-16586.	-.00017	-26989.	-.00033	-7501.	.00038	2602.	.00359	14036.	.00359	391.	.00075			
15 2	9253.	-.00014	30856.	.00031	19742.	.00037	-1864.	-.00327	15503.	.00352	-374.	-.00072			
15 3	-16280.	-.00017	-25869.	-.000315	-7240.	.00036	2369.	.00334	13384.	.00336	340.	.00065			
15 4	8442.	-.00018	28471.	.000326	18199.	.00035	-1829.	-.00309	14347.	.00328	-323.	-.00062			
15 5	-15842.	-.00020	-25123.	-.000303	-7067.	.00034	2214.	.00317	12949.	.00320	305.	.00059			
15 6	7632.	-.00023	26492.	.000361	16456.	.00032	-1794.	-.00291	13190.	.00305	-271.	-.00052			
15 7	-15218.	-.00025	-24004.	-.000255	-6804.	.00032	1921.	.00292	12296.	.00297	254.	.00049			
15 8	7091.	-.00026	24489.	.000284	15628.	.00031	-1770.	-.00279	12419.	.00289	-237.	-.00046			
15 9	-14560.	-.00029	-22865.	-.000267	-6546.	.00029	1744.	.00267	11443.	.00274	203.	.00039			
15 10	450.	-.00031	-1381.	-.00044	-752.	.00028	1086.	.00062	1945.	.00266	-1420.	-.00270			
15 11	-547.	-.00037	-7.	.00045	-692.	.00025	-1532.	-.00057	1618.	.00234	1445.	.00241			
15 12	-1553.	-.00043	-1102.	-.00028	-1232.	.00021	-1684.	-.00050	1292.	.00202	1249.	.00211			
15 13	-2559.	-.00049	-1835.	-.00042	-1472.	.00018	-2196.	.00011	966.	.00169	-1093.	-.00182			

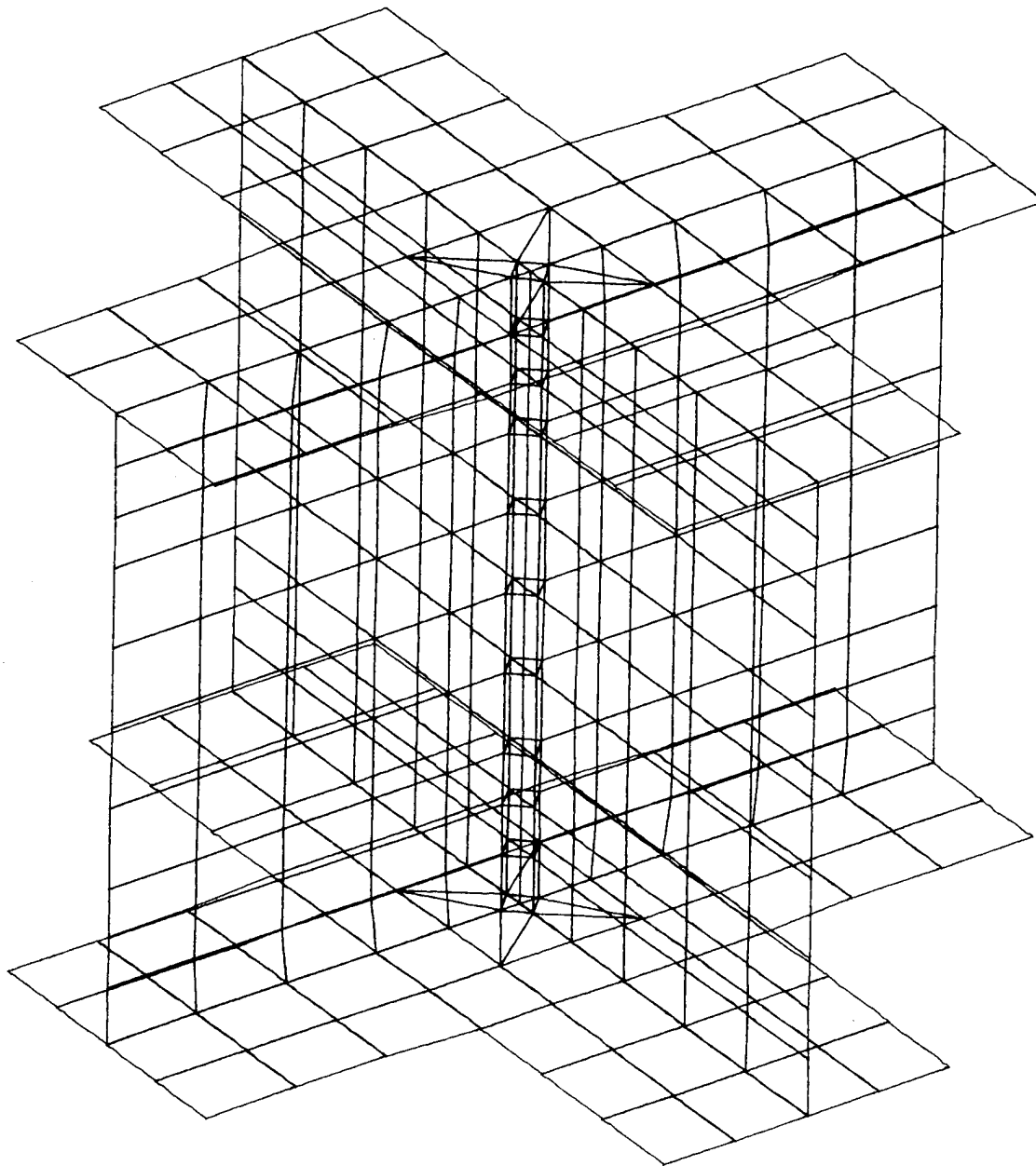

Figure (1).- Composite Cross Beam Finite Element Model,
Drawn Using SPAR.

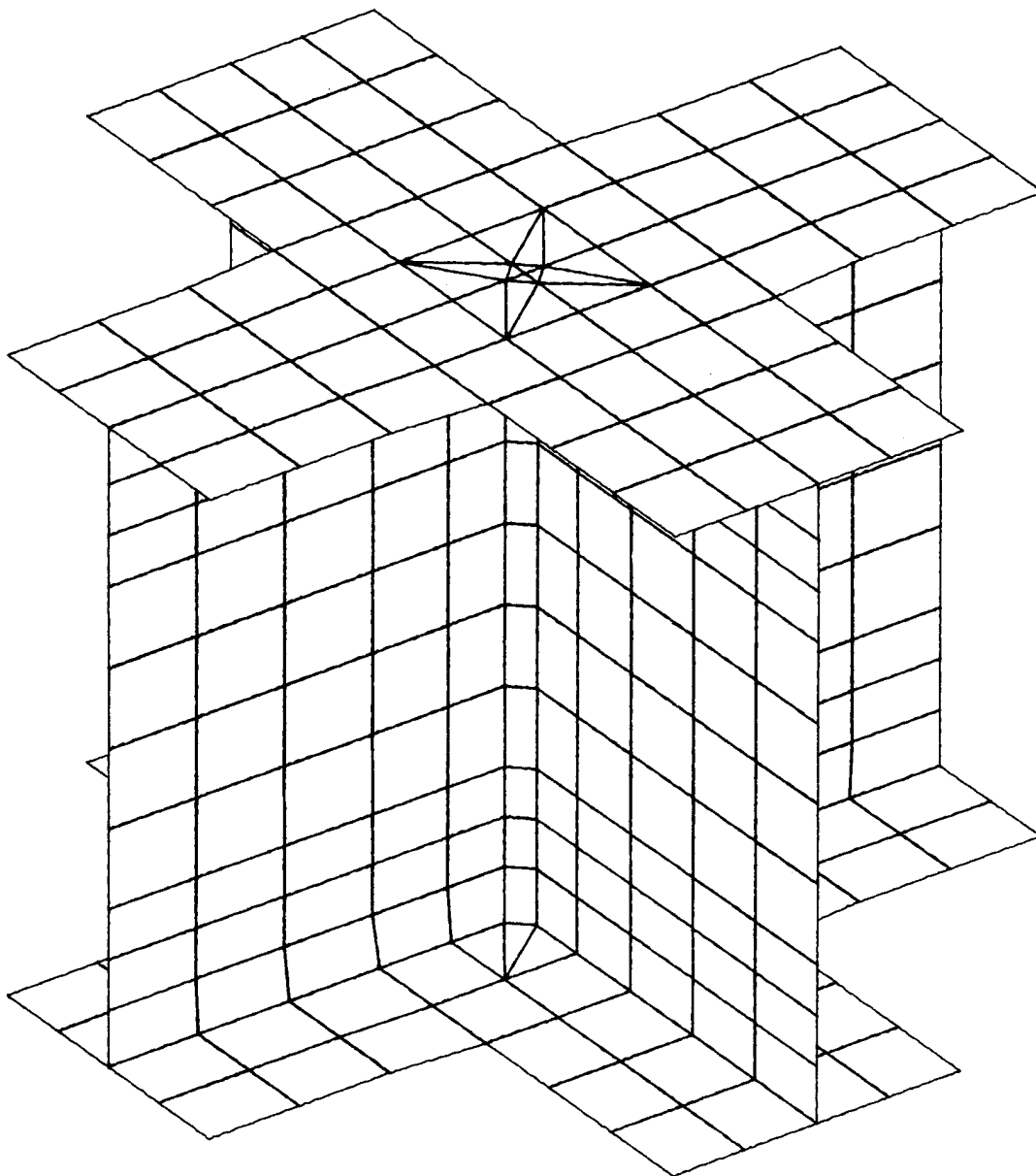

Figure (2).- Undeformed Composite Cross Beam Finite Element Model
With Hidden Lines Removed, Drawn Using HIDLIN.

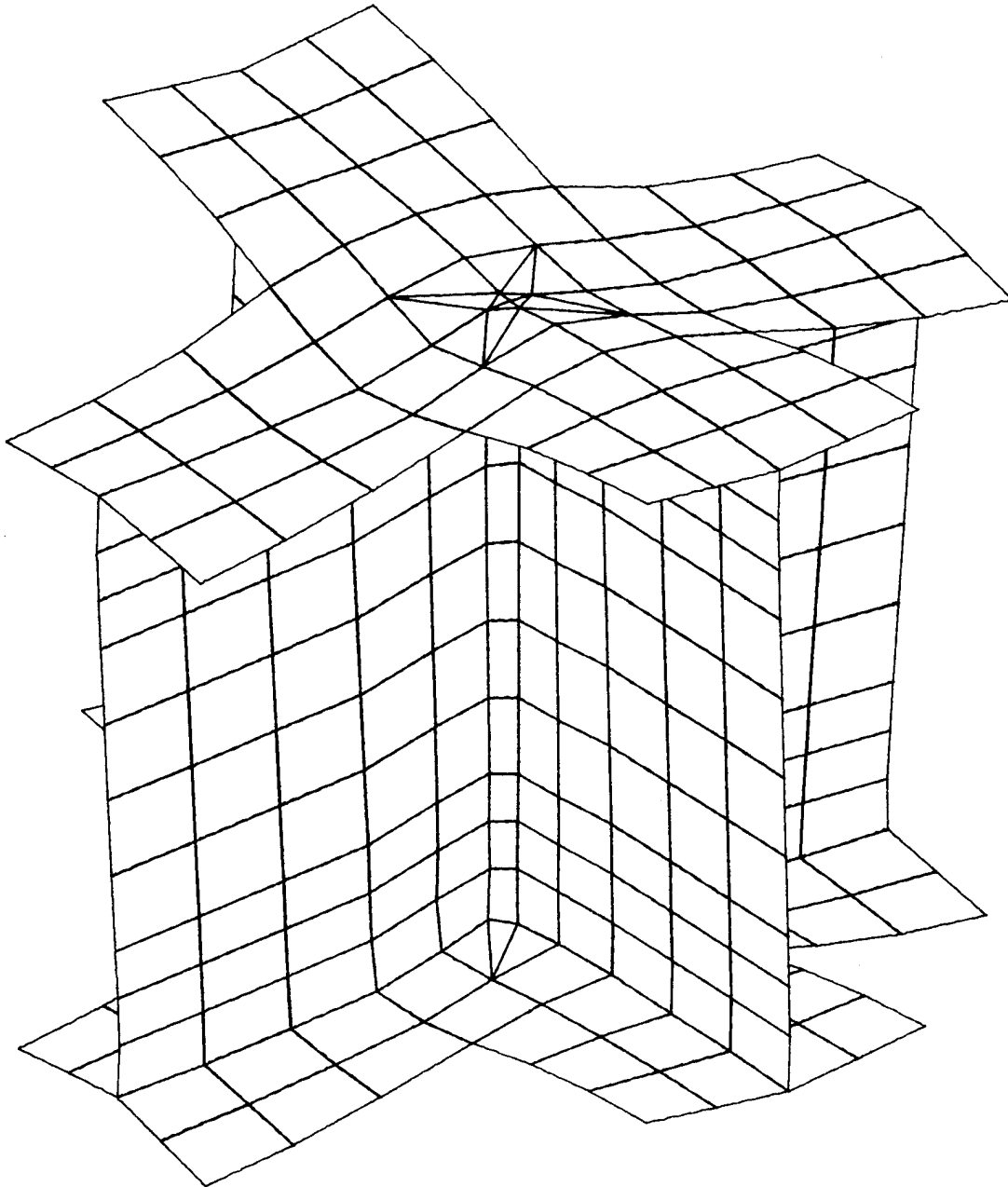

Figure (3).- Deformed Composite Cross Beam Finite Element Model
with Hidden Lines Removed, Drawn Using HIDLIN.

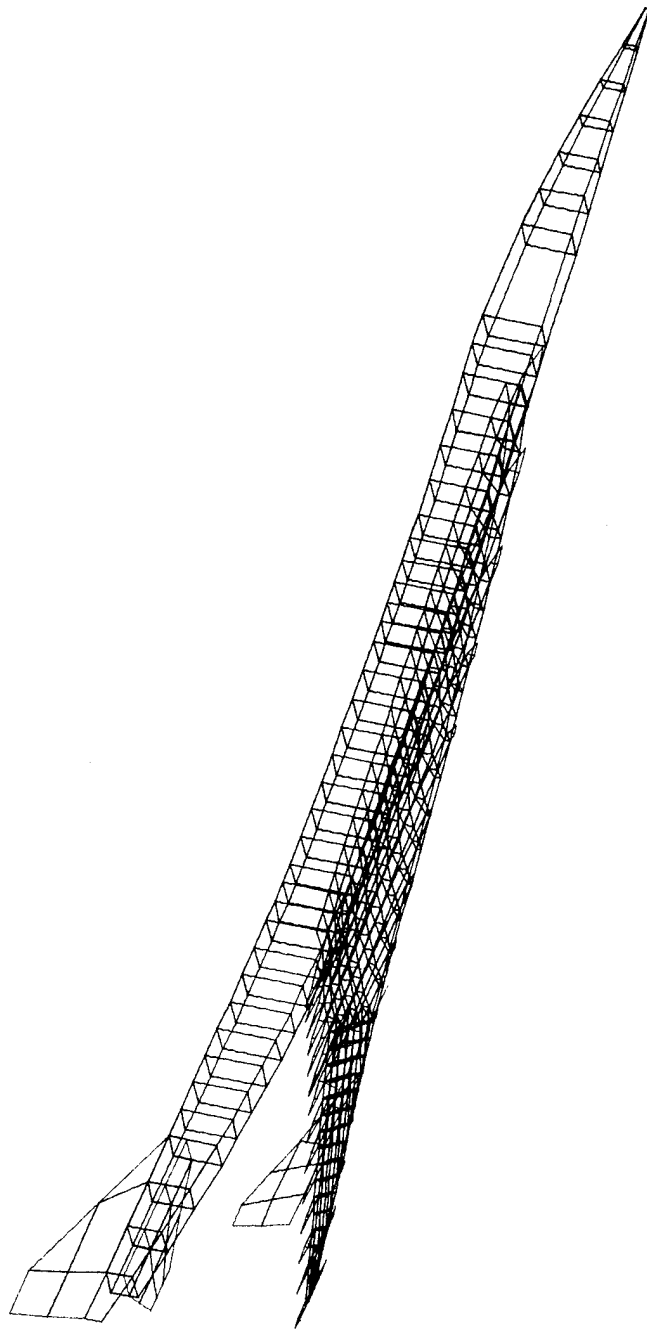

Figure (4).- Finite Element Model of Supersonic Cruise Aircraft, Drawn Using SPAR.

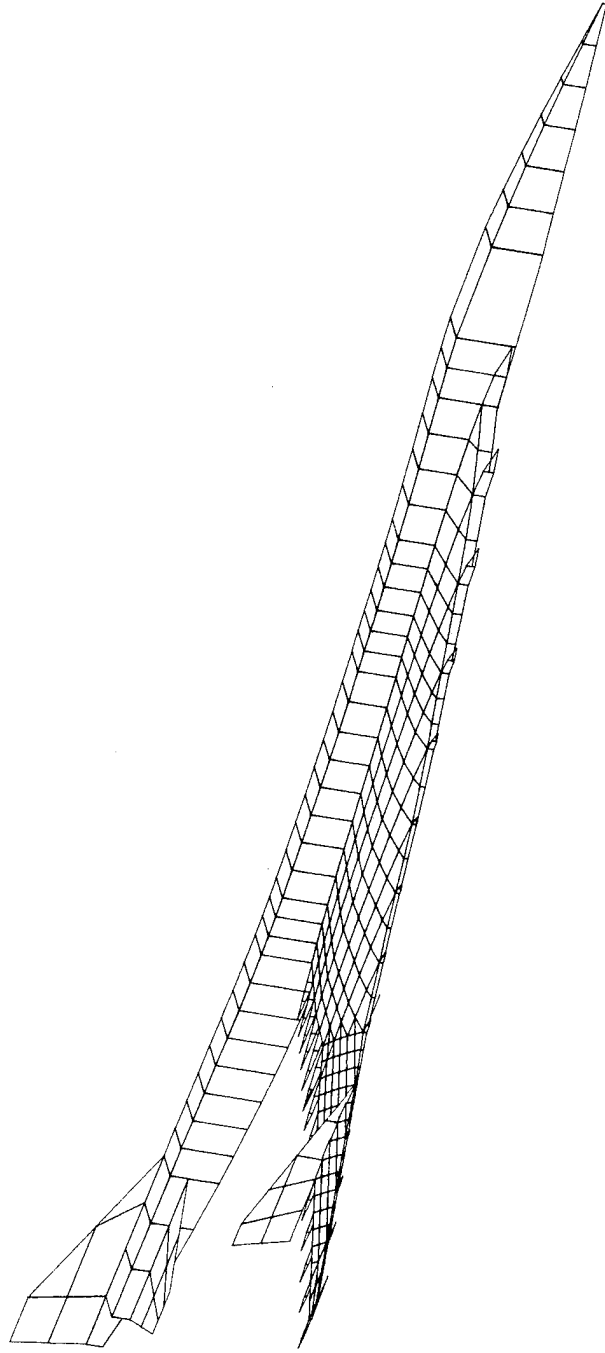

Figure (5).- Undeformed Finite Element Model of Supersonic Cruise Aircraft, Drawn Using HIDLIN.

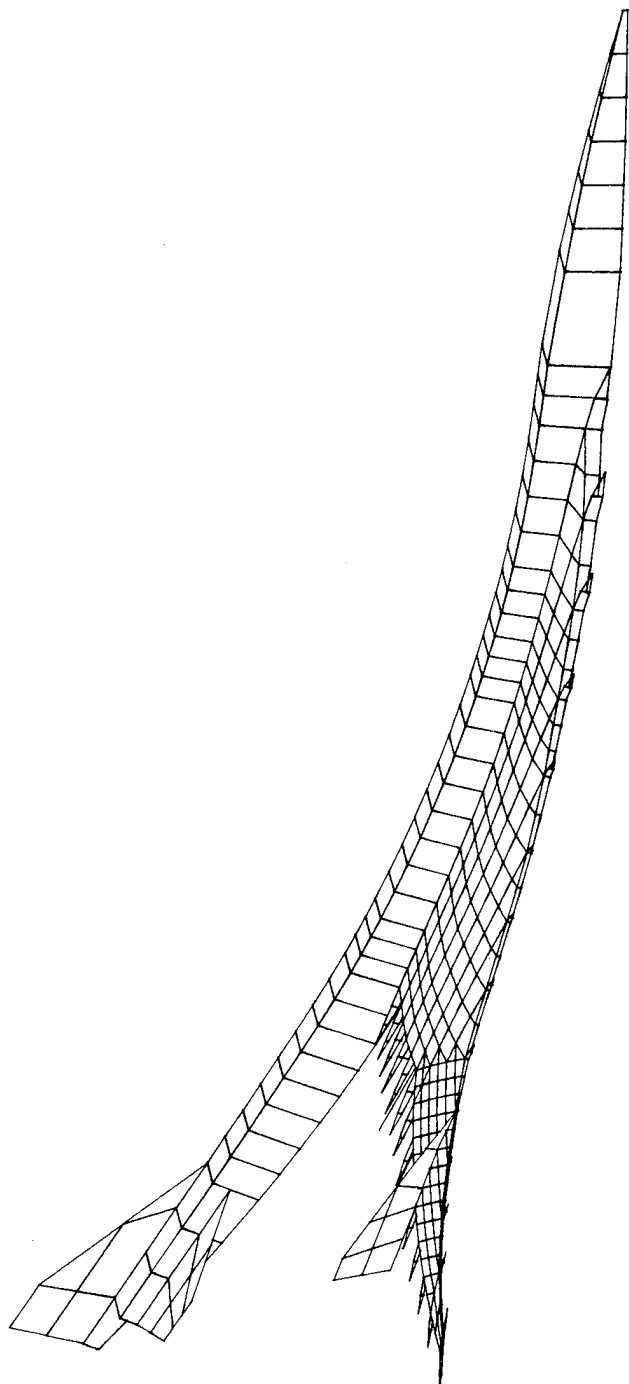

Figure (6).- Deformed Finite Element Model of Supersonic Cruise Aircraft, Drawn Using HIDLIN.

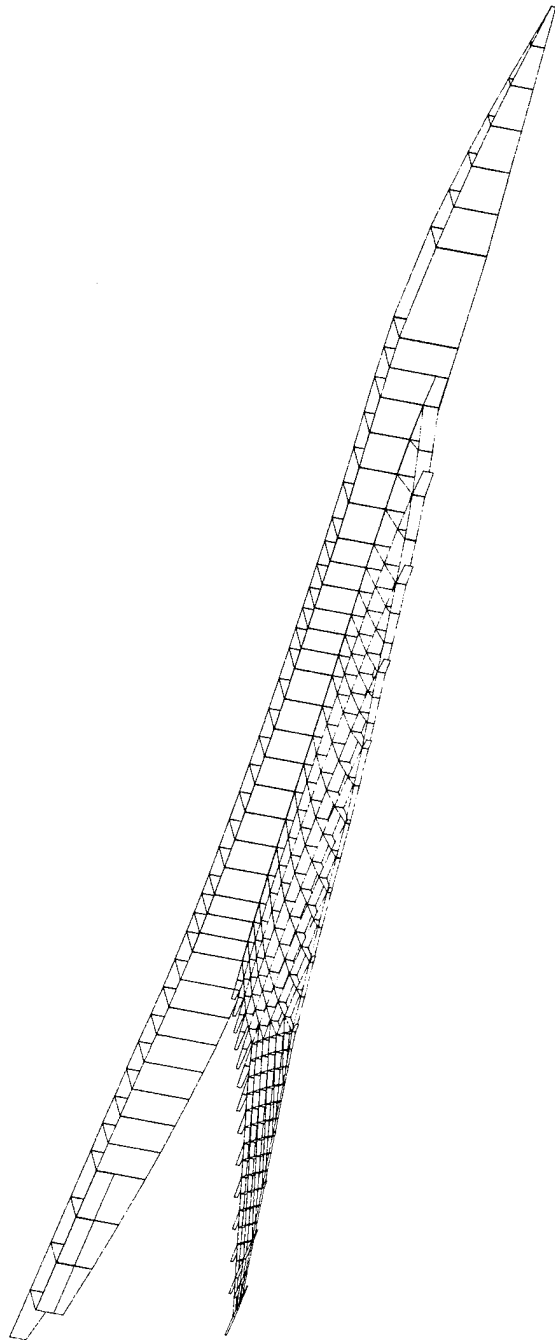

Figure (7).- Internal Finite Element Structure of Supersonic Cruise Aircraft,
Drawn Using HIDLIN.

DRAWN
HIDDEN
LINE

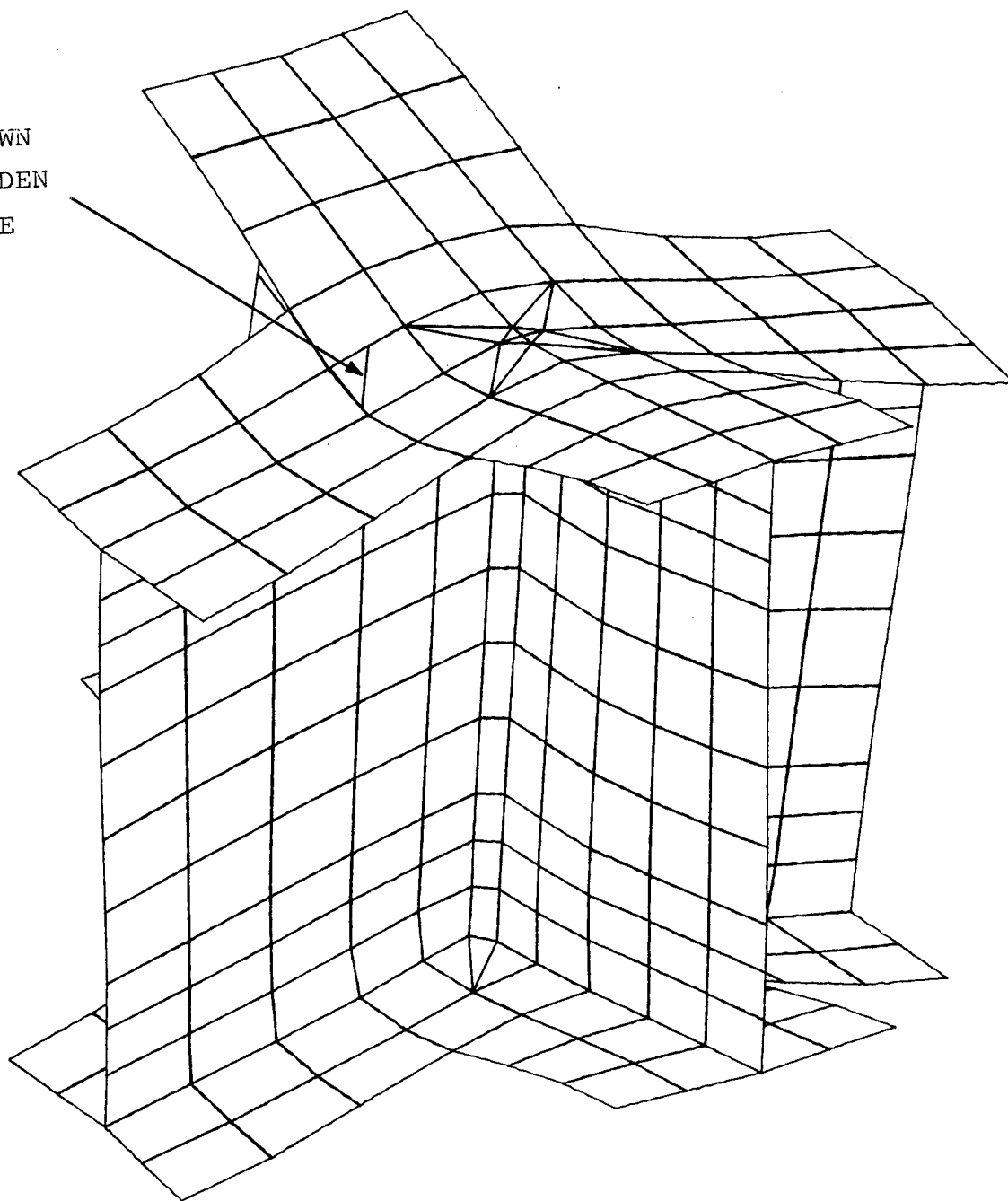

Figure (8).- Composite Cross Beam Finite Element Model With Most of The Hidden Lines Removed, Drawn Using HIDLIN.

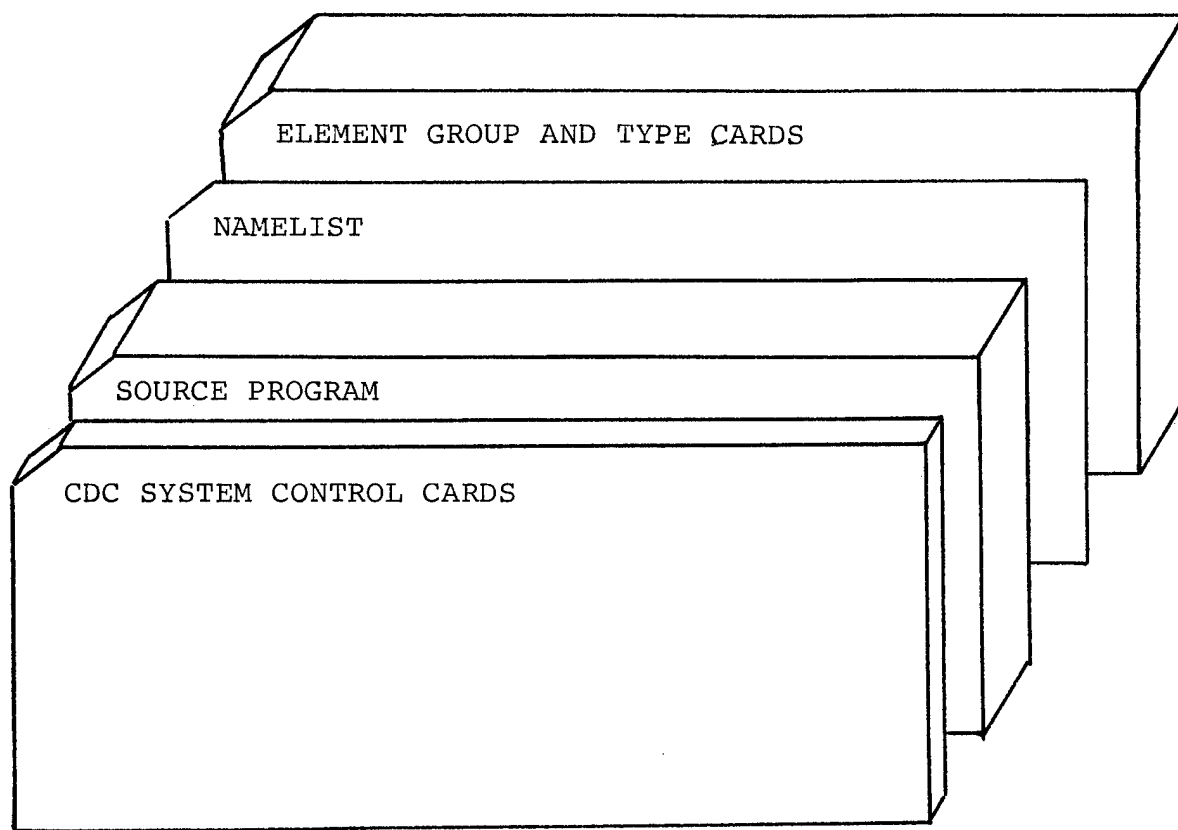

Figure (9).- Typical Program Setup.

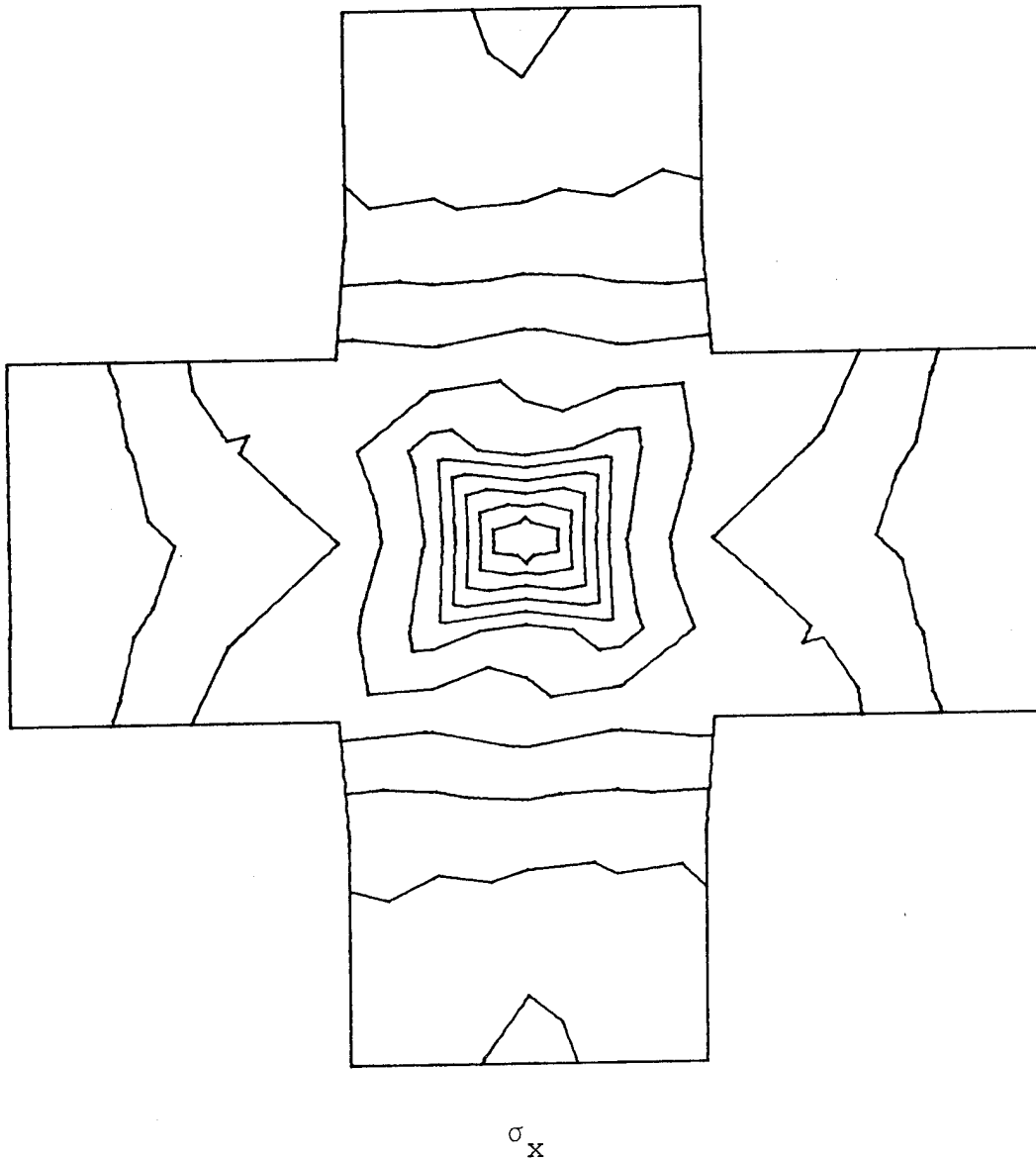
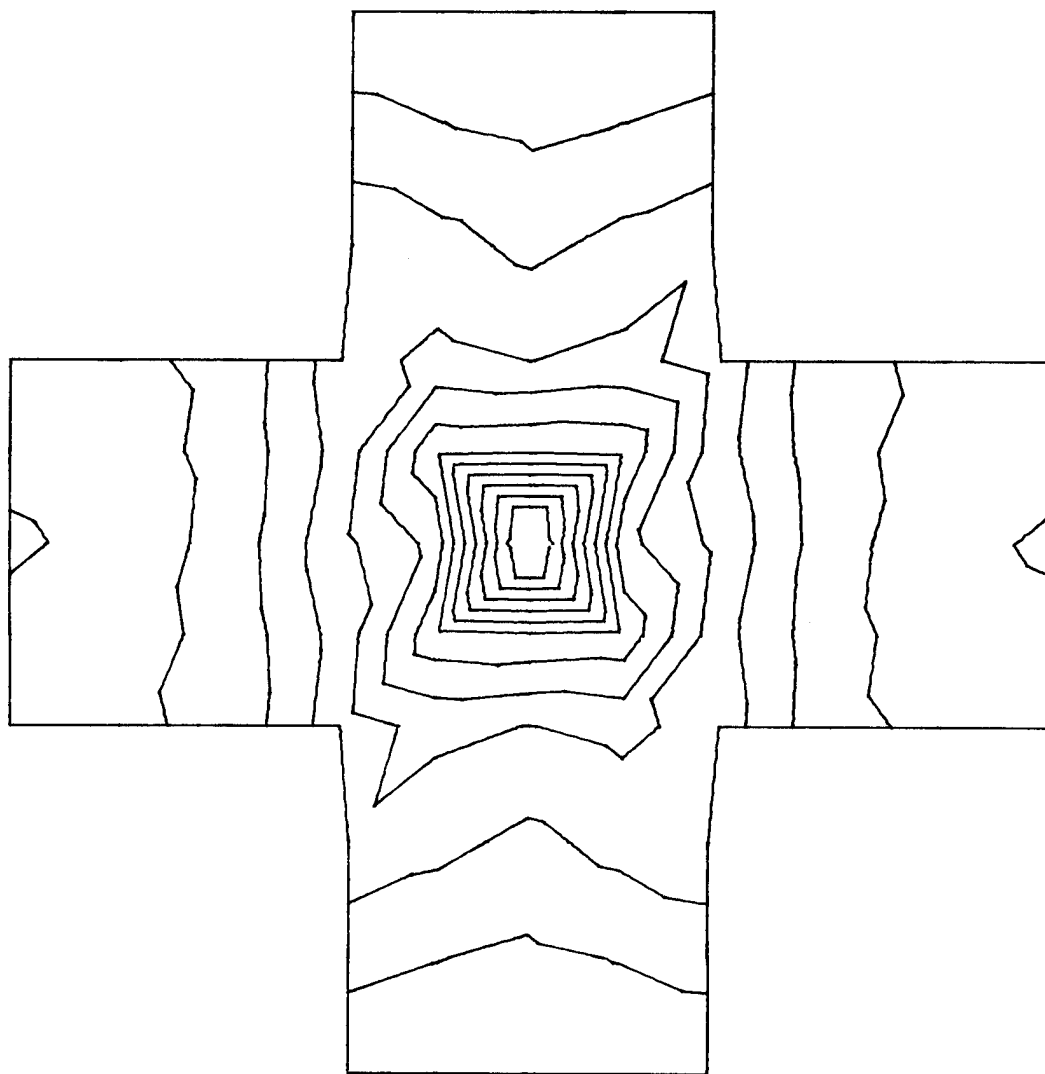
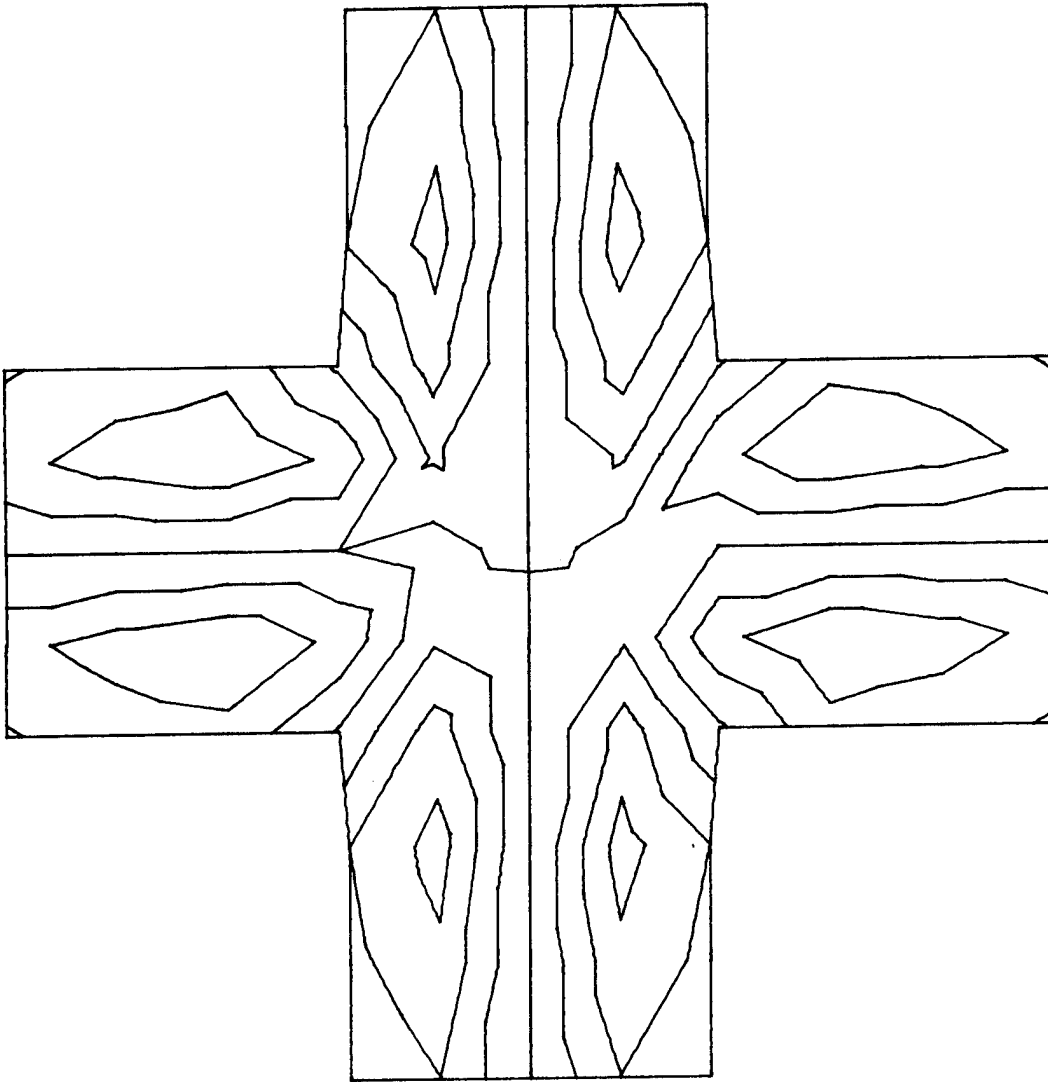

Figure (10a).- σ_x Stress Contours of Upper Flange of Composite Cross Beam Structure.



σ_y

Figure (10b).- σ_y Stress Contours of Upper Flange of Composite Cross Beam Structure.



τ_{xy}

Figure (10c).- τ_{xy} Stress Contours of Upper Flange of Composite Cross Beam Structure.

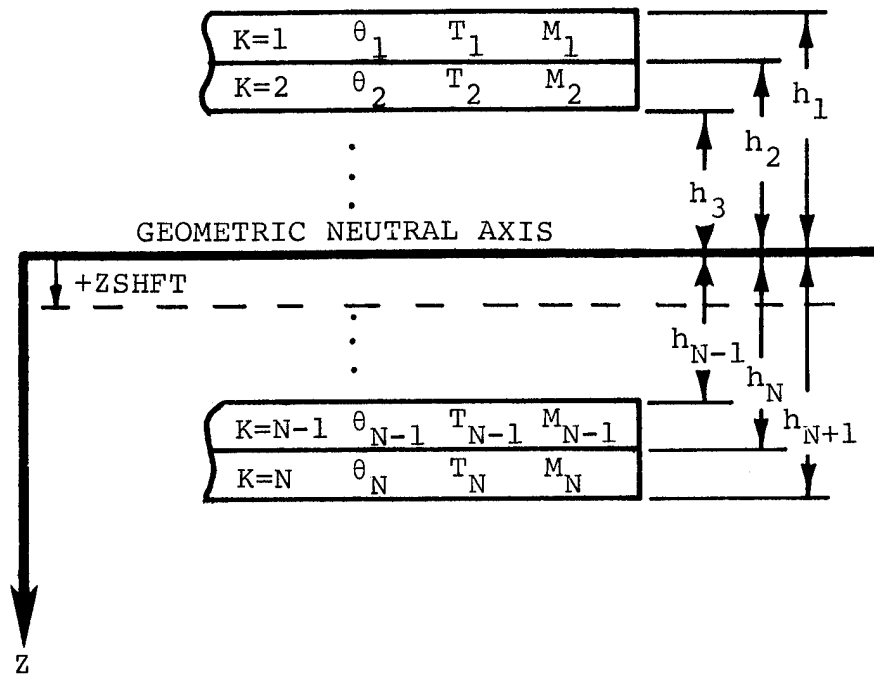

Figure (11a).- Composite Laminate Sign Convention and Construction.

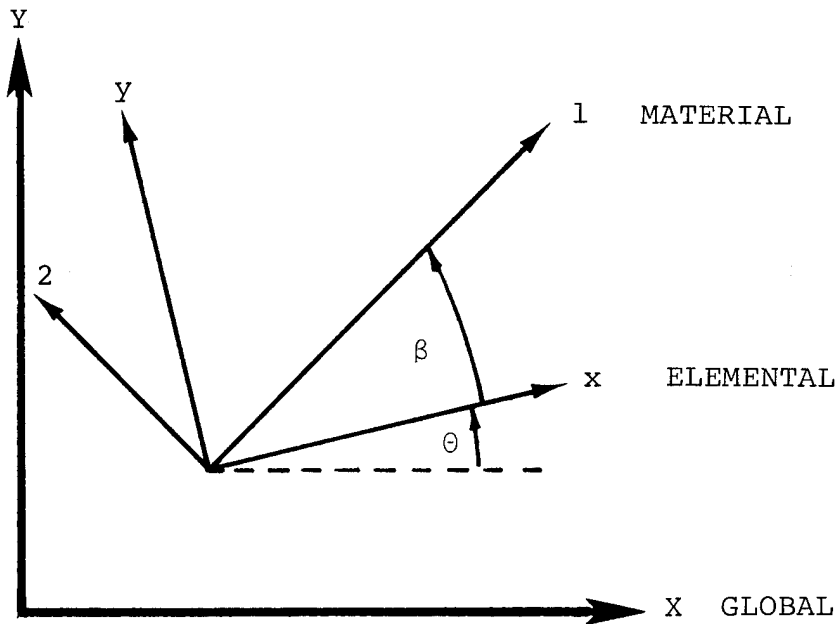

Figure (11b).- Composite Laminate Coordinate System.

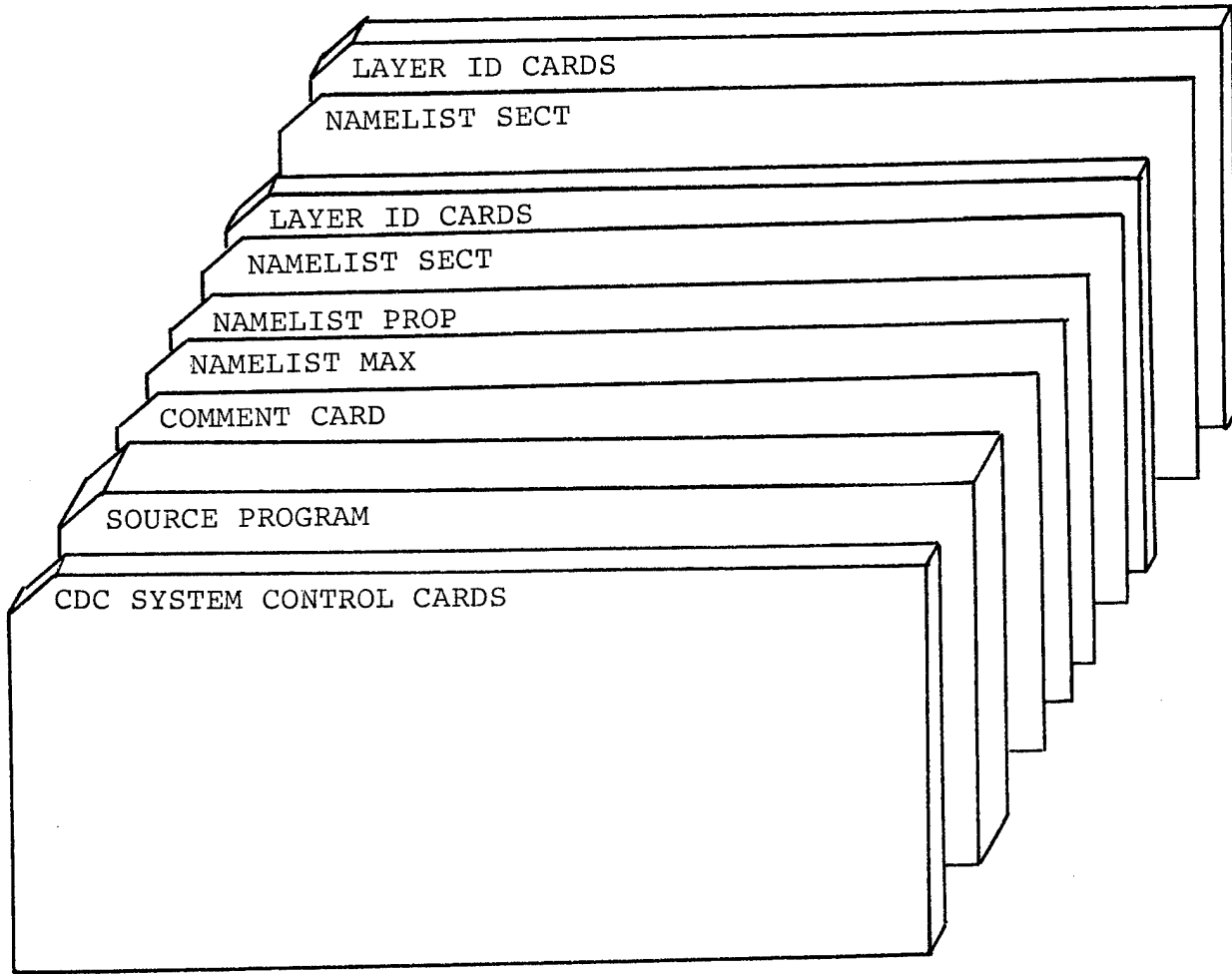

Figure (12).- Program SAT Deck Setup.

1. Report No. NASA TM-80209		2. Government Accession No.		3. Recipient's Catalog No.	
4. Title and Subtitle GRAPHICS AND COMPOSITE MATERIAL COMPUTER PROGRAM ENHANCEMENTS FOR SPAR				5. Report Date February 1980	
				6. Performing Organization Code	
7. Author(s) Garly L. Farley and Donald J. Baker				8. Performing Organization Report No.	
9. Performing Organization Name and Address NASA Langley Research Center Hampton, VA 23665				10. Work Unit No. 505-33-43-01	
				11. Contract or Grant No.	
12. Sponsoring Agency Name and Address National Aeronautics and Space Administration Washington, DC 20546				13. Type of Report and Period Covered Technical Memorandum	
				14. Sponsoring Agency Code	
15. Supplementary Notes The authors are employed by the Structures Laboratory, USARTL (AVRADCOM).					
16. Abstract The SPAR computer software system is used for finite element structural and thermal analysis. This report contains user documentation of additional computer programs that have been developed for use in conjunction with SPAR. These programs plot digital data, simplify input for composite material section properties and compute lamina stresses and strains. Sample problems are presented including execution procedures, program input and tabulated and graphical output.					
17. Key Words (Suggested by Author(s)) Computer Graphics SPAR Hidden Line Composite Materials Stress Contours				18. Distribution Statement Unclassified - Unlimited Subject Category 61	
19. Security Classif. (of this report) Unclassified		20. Security Classif. (of this page) Unclassified		21. No. of Pages 49	22. Price* \$4.50