



**US Army Corps
of Engineers**
Waterways Experiment
Station

Miscellaneous Paper EL-96-1
February 1996

A Prototype Microwave Probe and Reflectometer for In Situ Measurement of Soil Electrical Properties

by Joel B. Everett, John O. Curtis

19960321 092

Approved For Public Release; Distribution Is Unlimited

19960321 092

3025 GLENN DRIVE, WASHINGTON, DC 20315

Prepared for U.S. Army Corps of Engineers
Research and Development Directorate

The contents of this report are not to be used for advertising, publication, or promotional purposes. Citation of trade names does not constitute an official endorsement or approval of the use of such commercial products.



PRINTED ON RECYCLED PAPER

A Prototype Microwave Probe and Reflectometer for In Situ Measurement of Soil Electrical Properties

by Joel B. Everett, John O. Curtis

U.S. Army Corps of Engineers
Waterways Experiment Station
3909 Halls Ferry Road
Vicksburg, MS 39180-6199

Final report

Approved for public release; distribution is unlimited

Prepared for U.S. Army Corps of Engineers
Research and Development Directorate
Washington, DC 20314-1000



**US Army Corps
of Engineers**
Waterways Experiment
Station

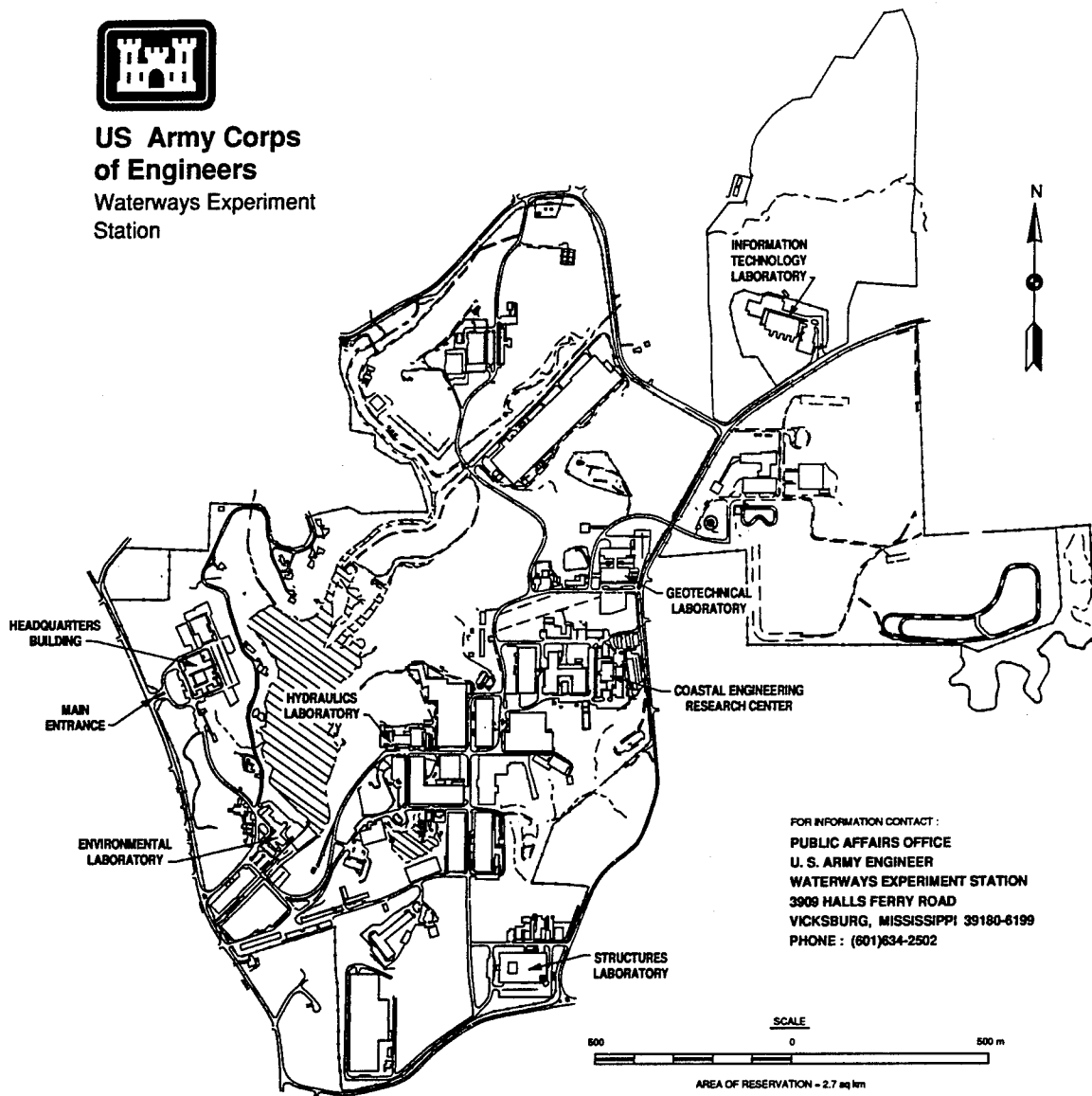

FOR INFORMATION CONTACT :
PUBLIC AFFAIRS OFFICE
U. S. ARMY ENGINEER
WATERWAYS EXPERIMENT STATION
3900 HALLS FERRY ROAD
VICKSBURG, MISSISSIPPI 39180-6199
PHONE : (601)634-2502

Waterways Experiment Station Cataloging-in-Publication Data

Everett, Joel B.

A prototype microwave probe and reflectometer for in situ measurement of soil electrical properties / by Joel B. Everett, John O. Curtis ; prepared for U.S. Army Corps of Engineers Research and Development Directorate.

82 p. : ill. ; 28 cm. -- (Miscellaneous paper ; EL-96-1)

Includes bibliographic references.

1. Soil moisture -- Measurement. 2. Reflectometer. 3. Microwave remote sensing. 4. Probes (Electronic instruments) I. Curtis, John O. II. United States. Army. Corps of Engineer. III. U.S. Army Engineer Waterways Experiment Station. IV. Environmental Laboratory (U.S. Army Engineer Waterways Experiment Station) V. United States. Army. Corps of Engineers. Research and Development Directorate. VI. Title. VII. Series: Miscellaneous paper (U.S. Army Engineer Waterways Experiment Station) ; EL-96-1.

TA7 W34m no.EL-96-1

Contents

Preface	v
Conversion Factors, Non-SI to SI Units of Measurement	vii
1—Introduction	1
Motivation	1
Applications	3
Horticulture	3
Site characterization	4
Report Content	5
2—Previous Sensor Developments	6
Published Papers	6
Current Commercial Devices	11
3—WES Prototype Sensor	15
Background	15
Probe Geometry	16
Theory of Operations	17
Basic relationships	19
Model for DCSR probe	21
Probe calibration	22
Soil measurements	23
4—Evaluation Measurements	25
Sample Volume Study	25
Initial Measurements on Real Materials	28
Soil Measurements	29
Repeated Measurements	32
5—Future Improvements and Applications	36
References	37
Appendix A: Operations Guide for DCSR Probe and Reflectometer	A1
Appendix B: Electrical Properties of Soils at 60 MHz	B1

SF 298

List of Figures

Figure 1.	A soil moisture measurement probe	7
Figure 2.	In vivo probe configurations	8
Figure 3.	Ohio State probe	9
Figure 4.	A radiating monopole probe	9
Figure 5.	An in vivo probe	10
Figure 6.	An X-band reflectometer	11
Figure 7.	Schematic of a Dutch soil moisture device in a cone penetrometer	13
Figure 8.	Schematic of a tined soil moisture probe	14
Figure 9.	DCSR system in use	17
Figure 10.	DCSR probe head	17
Figure 11.	Dimensions of DCSR probe head	18
Figure 12.	DCSR reflectometer box	18
Figure 13.	Switch configuration on DCSR box	19
Figure 14.	Schematic diagram of DCSR reflectometer	20
Figure 15.	Zone of influence measurement methodology	26
Figure 16.	Voltmeter recordings versus distance from side	27
Figure 17.	Voltmeter recordings versus distance from bottom	27
Figure 18.	Voltmeter recordings versus distance from top	28
Figure 19.	Laboratory data and empirical models for soil permittivity versus volumetric moisture	31
Figure 20.	DCSR and other laboratory data for soil #1	33
Figure 21.	DCSR and other laboratory data for soil #2	34

Preface

The report herein documents efforts at the U.S. Army Engineer Waterways Experiment Station (WES), made during the summer of 1994, to demonstrate that microwave technology can be utilized for the measurement of complex electrical properties of soils. Specific applications of such knowledge include prediction of electromagnetic energy attenuation in such devices as ground-penetrating radar and the measurement of changes in soil properties due to the presence of chemical contaminants. Financial support for this work came from two basic research projects funded by the U.S. Army Corps of Engineers Research and Development Directorate in Washington, DC: a project entitled "In Situ Obstacle Discrimination" (project number 61102/AT22) and a project entitled "The Microwave Response of Contaminated Soils" (project number 61102/AT25).

Mr. Joel B. Everett conducted the testing and evaluation of the probe hardware performance and was responsible for the electrical property data contained in Appendix B. The probe was fabricated by Mr. John Beauchamp, an employee of the Instrumentation Services Division at WES. Dr. John O. Curtis provided some of the background material, including a review of relevant literature and theory.

Permission to use copyrighted figures was obtained from IOP Publishing, Ltd, for Figures 1 and 5; The Institute of Electrical and Electronics Engineers, Inc., for Figures 2 and 4; and Vitel, Inc., for Figure 8.

This study was conducted under the direct supervision of Dr. Ernesto Cespedes, Chief, Environmental Sensing Branch, Environmental Engineering Division (EED), Environmental Laboratory (EL), and under the general supervision of Mr. Norman R. Francingues, Chief, EED, and Dr. John W. Keeley, Director, EL.

At the time of publication of this report, Director of WES was Dr. Robert W. Whalin. Commander was COL Bruce K. Howard, EN.

This report should be cited as follows:

Everett, J. B., and Curtis, J. O. (1996). "A prototype microwave probe and reflectometer for in situ measurement of soil electrical properties," Miscellaneous Paper EL-96-1, U.S. Army Engineer Waterways Experiment Station, Vicksburg, MS.

The contents of this report are not to be used for advertising, publication, or promotional purposes. Citation of trade names does not constitute an official endorsement or approval of the use of such commercial products.

Conversion Factors, Non-SI to SI Units of Measurement

Non-SI units of measurement used in this report can be converted to SI units as follows:

Multiply	By	To Obtain
degrees (angle)	0.01745329	radians
feet	0.3048	meters
inches	2.54	centimeters

1 Introduction

Motivation

As long as the electrical properties of any medium are properly defined, the behavior of electromagnetic fields in that medium can be predicted by the well-known collection of experimental laws known as Maxwell's equations. Consider a medium in which the rate of "free" charged particle flow is proportional to the strength of the applied electric field (Ohm's law) and also in which there exist atomic and molecular electric dipoles whose degree of alignment with an applied field is proportional to the strength of the field (a linear dielectric). If one further assumes that the free charge distribution in the medium is relatively homogeneous, then it can be shown that a simple manipulation of Maxwell's equations results in an equation that describes how an electromagnetic wave propagates through the medium. This equation is known as a modified wave equation (Griffiths 1981) and has the following form for either an electric field or a magnetic field:

$$\nabla^2 E = \mu \left[\epsilon \frac{\partial^2 E}{\partial t^2} + \sigma \frac{\partial E}{\partial t} \right] \quad (1)$$

where

E = either electric or magnetic field vector

μ = magnetic permeability of medium

ϵ = permittivity of medium

σ = electrical conductivity of medium

In the SI system of units, the dimensions of magnetic permeability, permittivity, and electrical conductivity are henrys/meter, farads/meter, and mhos/meter (or siemens/meter), respectively.

Clearly, the propagation of electromagnetic waves through any medium is controlled by its magnetic properties and its electrical properties (permittivity

and conductivity taken collectively). To properly model this phenomenon or to properly design an electromagnetic sensor that might be used to probe the medium, one must have a clear understanding of the electrical and magnetic properties of the medium.

If one assumes a plane-wave solution to the modified wave equation:

$$E = E_0 e^{i(\kappa x - \omega t)} \quad (2)$$

where

x = direction of wave normal

κ = is wave number, or propagation constant

ω = is radial frequency of wave

then one finds that the wave number is complex:

$$\kappa^2 = \mu\epsilon\omega^2 + i\mu\sigma\omega \quad (3)$$

Writing κ in the form:

$$\kappa = \kappa_+ + i\kappa_- \quad (4)$$

one can show that the components of the complex wave number are:

$$\kappa_{\pm} = \omega \sqrt{\frac{\epsilon\mu}{2} \left[\sqrt{1 + \left(\frac{\sigma}{\epsilon\omega}\right)^2} \pm 1 \right]} \quad (5)$$

The real part of the complex wave number determines the wavelength, λ , of the electromagnetic wave in the medium, the velocity of its propagation, v , and the index of refraction of the medium, n :

$$\lambda = \frac{2\pi}{\kappa_+}, \quad v = \frac{\omega}{\kappa_+}, \quad n = \frac{c}{v} = \frac{c\kappa_+}{\omega} \quad (6)$$

where c is the velocity of light waves. On the other hand, the imaginary part of the complex wave number determines the degree of amplitude attenuation of the electromagnetic wave. In fact, the distance of wave travel in which the amplitude is reduced by a factor of $1/e$ (or about one third) is called the skin depth, d , of the medium.

$$d = \frac{1}{\kappa} \quad (7)$$

Conductivity, the electrical property that is required to produce finite skin depths, becomes a significant parameter when the term, $(\sigma/\epsilon\omega)^2$, becomes significant in the expression for the complex wave number.

In summary, then, if the magnetic properties of the medium are not significantly different from those of air or a vacuum, all of the factors associated with the propagation of plane-wave electromagnetic energy through the medium; i.e., wavelength, propagation velocity, refraction angles, are strictly functions of its electrical properties (permittivity and conductivity).

The above development considered all of the material response that stayed in phase with the electric field to be lumped into the conductivity term and all that was 90 deg¹ out of phase with the electric field to be lumped into the permittivity term. Parallel and equivalent developments could have been carried out assuming that all of the electrical properties of a medium can be described either by a complex permittivity (also called the complex dielectric constant) or by a complex conductivity.

Applications

There are several disciplines in which a knowledge of the electrical properties of substances can either be used directly or indirectly to facilitate the solution of a problem. Many of the applications are associated with the impact of water molecules on the properties of the medium. Water molecules are electric dipoles and, thus, affect the permittivity of the substance. At the same time, the presence of water often contributes to the formation of ions in the medium which, in turn, is reflected in the conductivity of the substance.

Horticulture

Because of the strong influence of water on the electrical properties of substances, one might correctly assume that the amount of water in a substance could be determined by a measurement of its electrical properties (Curtis, Weiss, and Everett 1995). Later in this report, experimental data and a suggested empirical model will be presented that establishes the relationship between permittivity measurements and volumetric moisture content in a wide variety of soils. Being able to quickly and accurately assess the amount of moisture in soils is vital to the horticultural industry. Armed with this information, farmers can optimize their irrigation practices to relieve plant stress

¹ A table of factors for converting non-SI units of measurement to SI units is presented on page vii.

and promote growth as well as to maximize the effectiveness of herbicide and pesticide applications. Once a food product is harvested, real-time moisture determination is vital to the processing, packaging, and distribution industries. Similar arguments can be made to support the need for improved moisture determination in plant nursery business and in forestry (Commonwealth Scientific and Industrial Research Organization 1974).

Site characterization

Many questions are now being raised in an environmentally sensitive society that require the ability to probe beneath the surface of the earth without actually digging it up (one might also call this nondestructive testing). For example, it might be necessary to establish the location of the water table at some test site without drilling numerous sampling wells (a very expensive process). The existence of distinct soil layers may be important for construction purposes or for predicting the flow of subsurface water (and possibly contaminants). More and more importance is being placed on trying to identify subsurface contamination without disturbing the terrain so that effective remediation techniques can be applied.

Numerous microwave technologies are available for characterizing terrain. Among these are reflectometers, the subject of this report, and ground-penetrating radars. The specific type of reflectometer being examined in this study is an open-circuit coaxial cable whose diameter is too small to allow for the launching of microwave energy. Permittivity and conductivity of the substance against which the cable is placed is measured by how the shunt capacitance and conductance of the cable change from those of the calibration standards. A more detailed analysis of this particular reflectometer will be presented in a later chapter.

One scenario for use of such a reflectometer is to make it part of a cone penetrometer system in which it would provide a detailed depth profile of electrical properties as the penetrometer was pushed into the earth. Such a profile would be an indicator of changes in moisture levels and possibly changes in soil type and would be used with other geophysical sensors in the probe to more completely characterize the test site. Numerous pushes of the penetrometer would provide a three-dimensional map of subsurface conditions. In some special situations, a reflectometer in a probe could also provide an indication of the presence of contaminant plumes or dense pockets of certain contaminants that might displace groundwater.

Ground-penetrating radars have been used for decades to locate highly conductive objects near the surface of the terrain. They suffer from two major drawbacks. First of all, their ability to spatially resolve subsurface features is severely limited by poor angular resolution. Improved knowledge of the electrical properties of the terrain being characterized could help in each situation. It is possible (although much research remains to be done in this area) to improve subsurface angular resolution of ground-penetrating

radars through the use of synthetic aperture data processing, which requires accurate estimates of propagation velocities.

Secondly, the attenuation of electromagnetic waves in clayey soils containing large volume percentages of water is quite large compared with that for dry sandy soils. Knowledge of the attenuation properties of the terrain being characterized would allow for the selection of the optimum ground-penetrating radar for the particular site conditions. Mode and frequency of operation as well as transmitting power levels and receiver sensitivity could all be selected to optimize the tradeoff between requirements for depth of penetration and spatial resolution.

Report Content

The purpose of this report is to document the current state of development of a real-time, microwave reflectometer that can be used to measure, in situ, the electrical properties of liquids, fine-grained mixtures, or any substance having a reasonably smooth surface. Following a summary of previous, related developments in order to establish a historical perspective, an outline of the reflectometer design being studied at the U.S. Army Engineer Waterways Experiment Station (WES) is presented. A number of simple experiments are then described that were used to help define some of the operational restrictions on the device. The main body of the report closes with suggestions for how the device could be improved to provide the potential user with the most "friendly" measurement tool possible as well as some thoughts on how the sensor technology could be adapted to a penetrometer geometry for collecting subsurface depth profiles of critical terrain characteristics.

2 Previous Sensor Developments

Published Papers

A review of the literature reveals a number of previous attempts to develop sensors that are capable of measuring the electrical properties of substances. Most of them operate on the same principle as that described earlier, where changes in the “fringe” capacitance of the sensor when placed against the substance being tested are used to determine electrical properties. Attention is given in the following paragraphs to those systems that were, or are, intended for in situ use. Applications of these devices focused almost exclusively on soil moisture measurements and measurements of human tissue.

One of the best, and earliest, references for in situ probe development is a paper from England on a device that could be used for soil moisture measurements (Thomas 1966). Pictured in Figure 1, the probe was wedge shaped and could be pushed into soft soil by hand. This device operated at a frequency of 30 MHz. The author developed an empirical relationship from laboratory data that allows one to calculate a volumetric moisture content from a probe measurement of the relative permittivity of the substance. It is not known how much this particular probe was used, but it is informative to note that the author closed with the observation that the large-scale applications of the technology depended on the production of an affordable and accurate very high-frequency capacitance meter.

Another reference to an electrical property probe was a patent for a 1-MHz borehole device that could be used to measure soil permittivity (Arulanandan 1980). Numerous geometries were suggested and circuit block diagrams were shown that would allow the probe to measure both capacitance and resistance of the soil. Access to soil at different depths was accomplished by drilling of a borehole to the desired depth, retracting the drill bit, and attaching the probe to the drill before lowering it to the bottom of the hole and into the soil at that depth. The inventor claims that this device is capable, through clever processing of the data, of registering many engineering properties of the soil such as density, porosity, friction angle, and many other quantities.

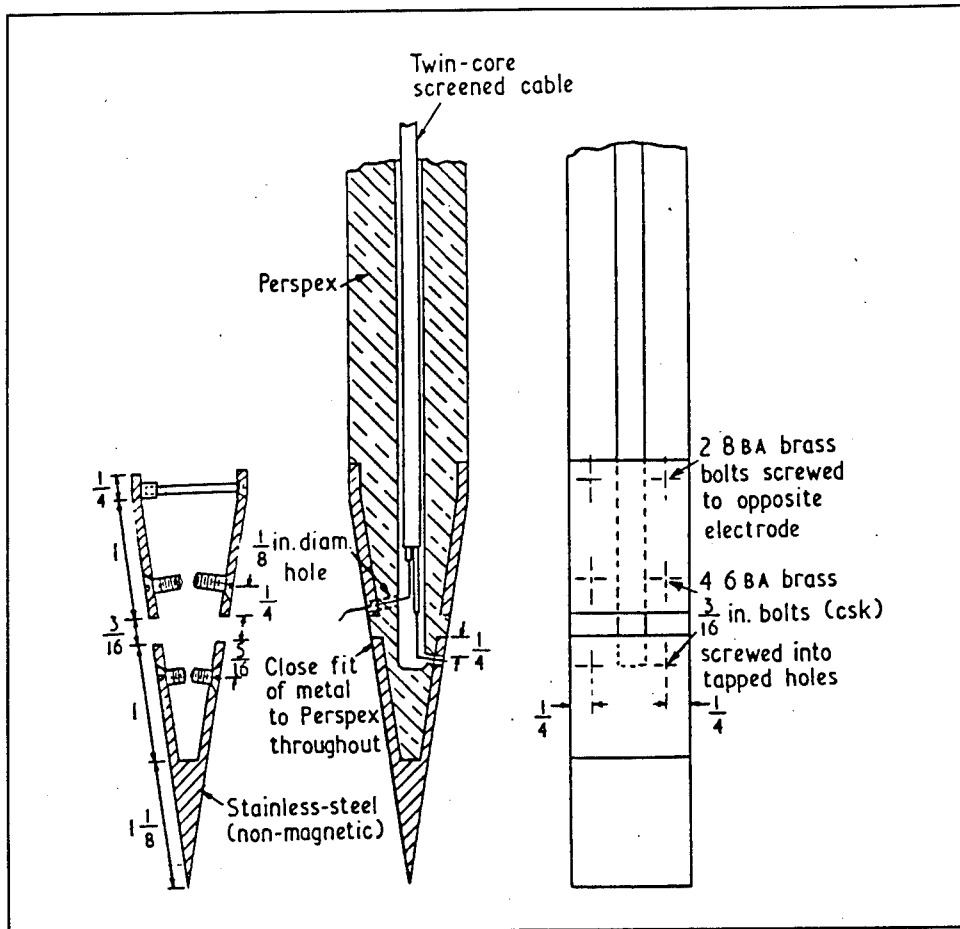

Figure 1. A soil moisture measurement probe (Thomas 1966)

In 1980, a paper was written on the use of a microwave probe that was designed to be used on the tissue of living human beings (Burdette, Cain, and Seals 1980). Although not truly portable (since it required the use of a sophisticated and large network analyzer), the device was designed to provide real-time results over a broad range of frequencies (100 MHz to 10 GHz). While one configuration of the probe was that of a monopole antenna (achieved by extending the probe center conductor to the desired length), most of the measurements were taken with what amounted to an open coaxial line, either with or without a circular ground plane, as shown in Figure 2. The purpose of pursuing this configuration was to explore the possibility of using such a device to distinguish healthy from diseased tissue or to possibly detect certain drugs in a human's bloodstream.

In the early 1980s a commercially produced electromagnetic probe for studying the properties of substances such as soils was not available. This laboratory had a need to be able to quickly and accurately measure the electrical properties of soils as one element of a larger study on techniques to detect intruders at sensitive military facilities. To fill the need, a contract was let to the Ohio State University's Electrosience Laboratory to develop a microwave

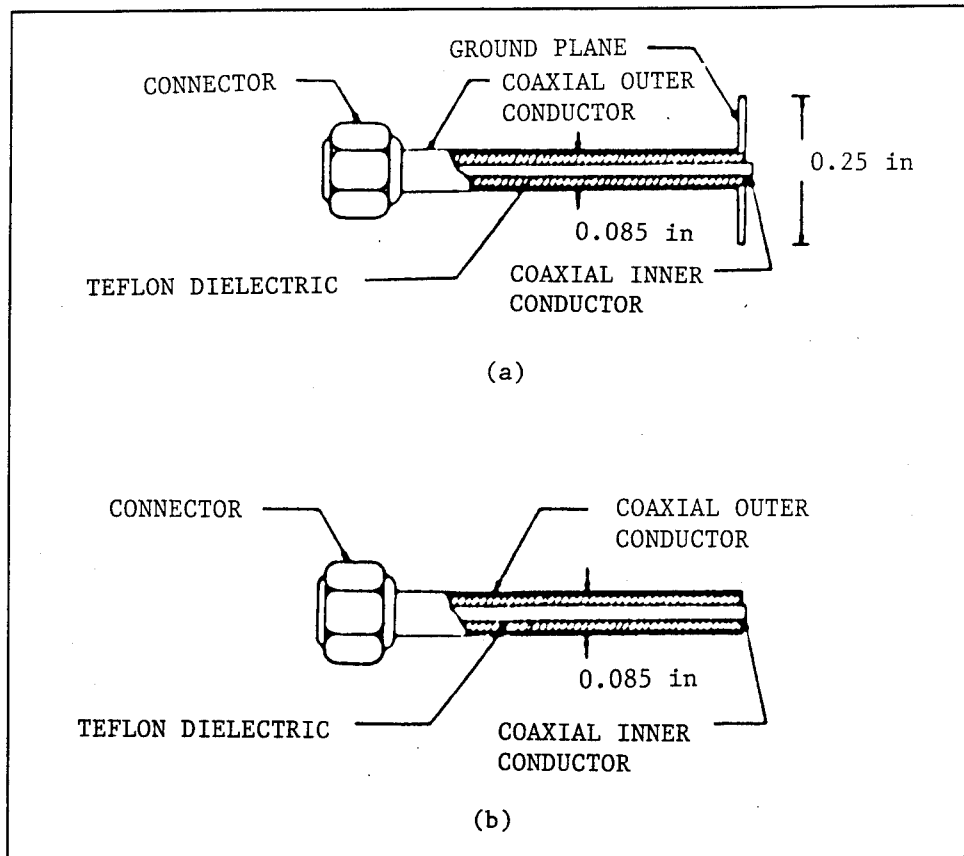

Figure 2. In vivo probe configurations (Burdette, Cain, and Seals 1980)
 (© 198x IEEE)

probe that could be inserted into relatively shallow hand-augured boreholes. The result was the probe sketched in Figure 3 in which a coaxial line was terminated in two semicylindrical brass plates and whose electric field lines extended laterally into the soil at the boundary of the borehole. Measurements could be made at either 40 or 60 MHz. The probe that will be discussed in this report is a modification of the Ohio State design.

Olson and Iskander (1986) developed a monopole probe similar to that of Burdette that was more suitable for measuring the dielectric properties of low-permittivity substances such as rocks. This device, shown in Figure 4, had an extended center conductor that allowed for radiation of energy from the probe. Laboratory measurements were reported for a frequency range of 100 MHz to 1 GHz, with some specific data reported at 400 MHz. References to field applications of this probe have not been found.

The mid-1980s also found a flurry of papers written on probes designed specifically for measurements of human tissue. One such device whose developers published a paper in 1986 operated in the time domain rather than the frequency domain, as had all of the previous systems (Gabriel, Grant, and Young 1986). The paper presents human skin permittivity and conductivity

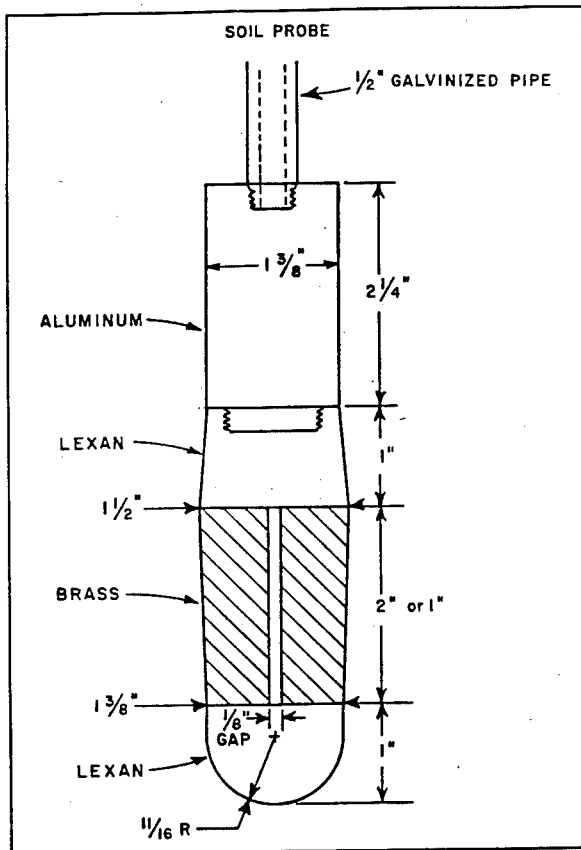

Figure 3. Ohio State probe (Caldecott, Poirier, and Svoboda 1985)

data over a range of frequencies from 1 MHz to 10 GHz. Applications of this probe (Figure 5) suggested by the developers included assessing the pathological condition of tissue or measuring the properties of highly viscous liquids such as concentrated solutions of DNA.

Another microwave probe that operated in the 1-MHz to 10-GHz frequency range (but in a time-domain mode) and was intended for use on human tissue was also reported in 1986 (Bose, Bottreau, and Chahine 1986). The configuration of this device was slightly different from earlier designs in that both the inner and outer conductors of the coaxial line were terminated at needles that penetrated the tissue to form

a dipole system. The authors reported measurements made on beef muscle and fat and compared them with human tissue data from other sources.

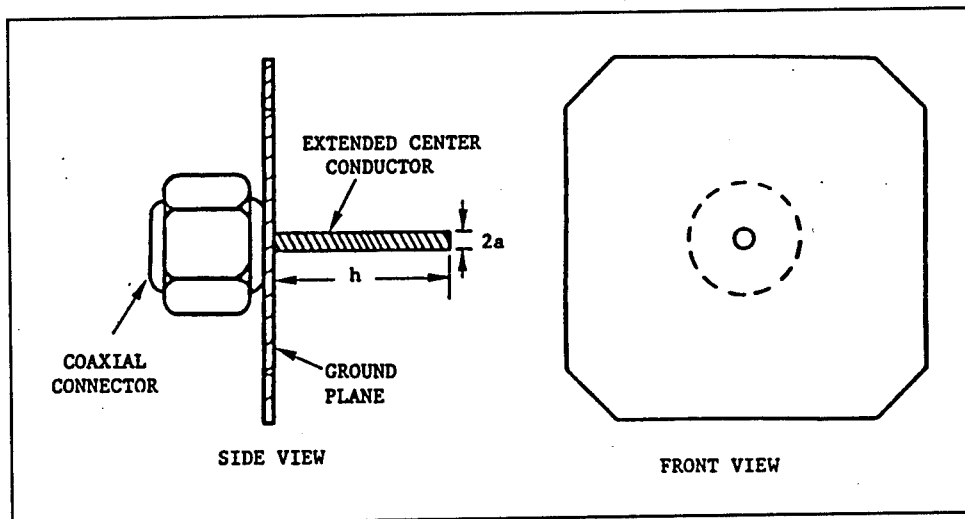

Figure 4. A radiating monopole probe (Olson and Iskander 1986) (© 198x IEEE)

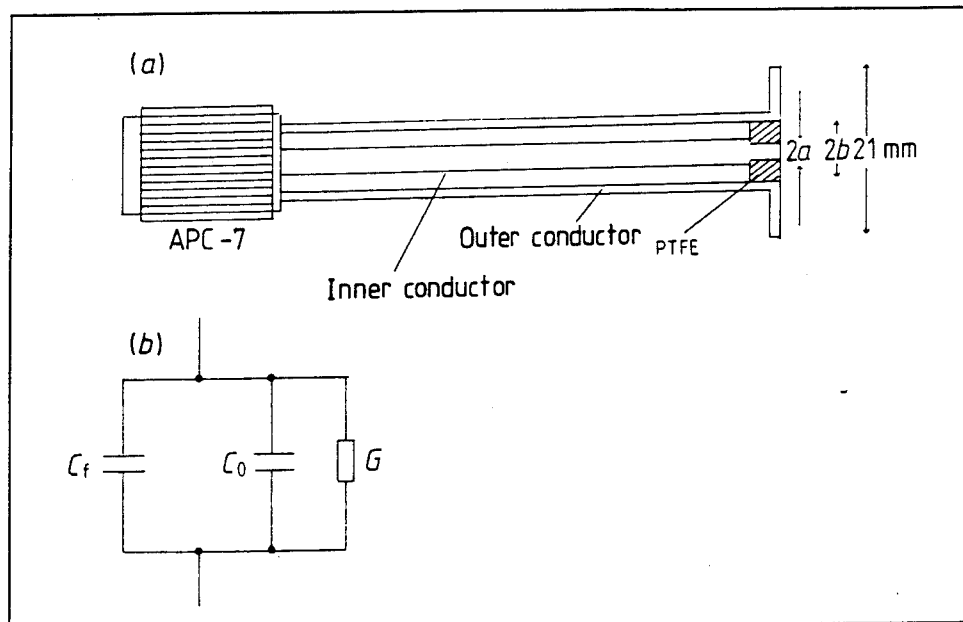

Figure 5. An in vivo probe (Gabriel, Grant, and Young 1986)

A second invention attributed to Arulanandan and for the measurement of electrical properties of soil was awarded in 1987 (Arulanandan and Arulanandan 1987). This appears to be an improvement over the earlier designs and suggests that the device could be used in a penetrometer mode, rather than being dropped into a previously excavated borehole. The patent also indicates that the range of frequencies of measurement are 2 to 30 MHz. In this device, the inner and outer conductors terminate in ring electrodes on a cylindrical shaft separated by dielectric spacers.

A very promising dielectric property probe was developed and marketed in the mid-1980s that had the potential to be a very effective soil moisture measurement device (Brunfeldt 1987; Lawrence 1989; Jackson 1990). Its design was that of an open-ended coaxial line that utilized a unique dual-channel reflectometer configuration to derive the complex dielectric constant from a measurement of the amplitude and phase of reflected signals. Its mode of operation was single-frequency continuous wave, numerous frequencies being available including 1.25, 4.8, 10, and 18 GHz. One of the problems with this probe was the combination of relatively high frequencies and small probe dimensions that resulted in a fairly small volume of soil being affected by the electric field line. The commercial venture that attempted to market these devices apparently failed; nothing has appeared in the literature on the use of these probes in the last several years.

While virtually all of the systems for measuring electrical properties of substances that were referenced in the literature consisted of an apparatus that made physical contact with the material in question, one device made use of an X-band (about 9.4 GHz) horn antenna to measure the phase and amplitude of the complex reflectivity (Arcone and Larson 1988). Shown schematically

in Figure 6, this reflectometer was found to give good results for lossy materials with very flat surfaces; however, it was found to give unreliable results for low-loss materials having multiple layer geometries. Uneven surfaces resulted in too much phase sensitivity.

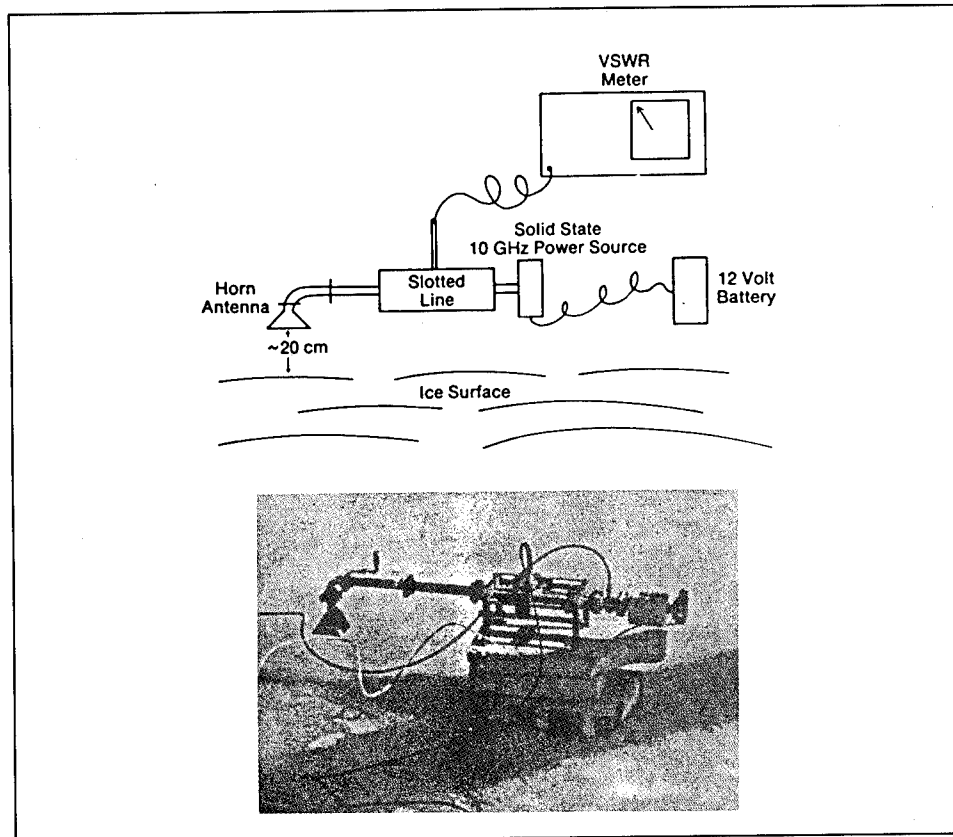

Figure 6. An X-band reflectometer (after Arcone and Larson (1988))

Another attempt to relate reflected energy to electrical properties (and in this case, soil moisture) was through the use of an open-ended waveguide sensor that is either placed against the soil surface or elevated to a known distance above the soil (Parchomchuk, Wallender, and King 1990). In this latter mode, it might be thought to operate somewhat like the horn reflectometer reported by Arcone and Devaney and might help explain their poor results for layered media. The waveguide sensor is attached to a vector network analyzer, meaning that much work remains to produce a field-portable device.

Current Commercial Devices

At least two products similar to what was discussed above are available today on the commercial market. Their application is for the measurement of soil moisture. A third sensor is in the final stages of development.

kilohertz range. One mode of operation of the Troxler probe requires the drilling of a borehole and the insertion of a 2-in.-diam polyvinyl chloride pipe into which the probe is lowered. In another mode, the probe can be buried within the soil. The cost of each probe is on the order of a thousand dollars, and a data controller designed to monitor up to eight probes simultaneously is on the order of three thousand dollars.

A second measurement system has been marketed recently by a Dutch firm (Hilhorst et al. 1995) and appears to be very similar in physical design to the devices described by Arulanandan in 1987. Advertised as an attachment to commercial cone penetrometer systems, this probe, shown schematically in Figure 7, operates at about 20 MHz. It uses the proven frequency-domain procedure described in many paragraphs above to calculate permittivity and conductivity. The probe has proven very successful in saturated soils, but requires further calibration in unsaturated soils. No information is available on the cost of this device and its associated hardware and software.

One last soil moisture probe has been developed in this country by a private engineering firm. This device, whose schematic is shown in Figure 8, operates like many of the other capacitive probes except that it creates a known volume of soil to be measured by enclosing the soil within a circular arrangement of stainless steel tines (Campbell 1988; Vitel, Inc. 1994). This device would be ideal for making measurements in reasonably soft soils at the surface of the ground or in the exposed surfaces of excavation pits.

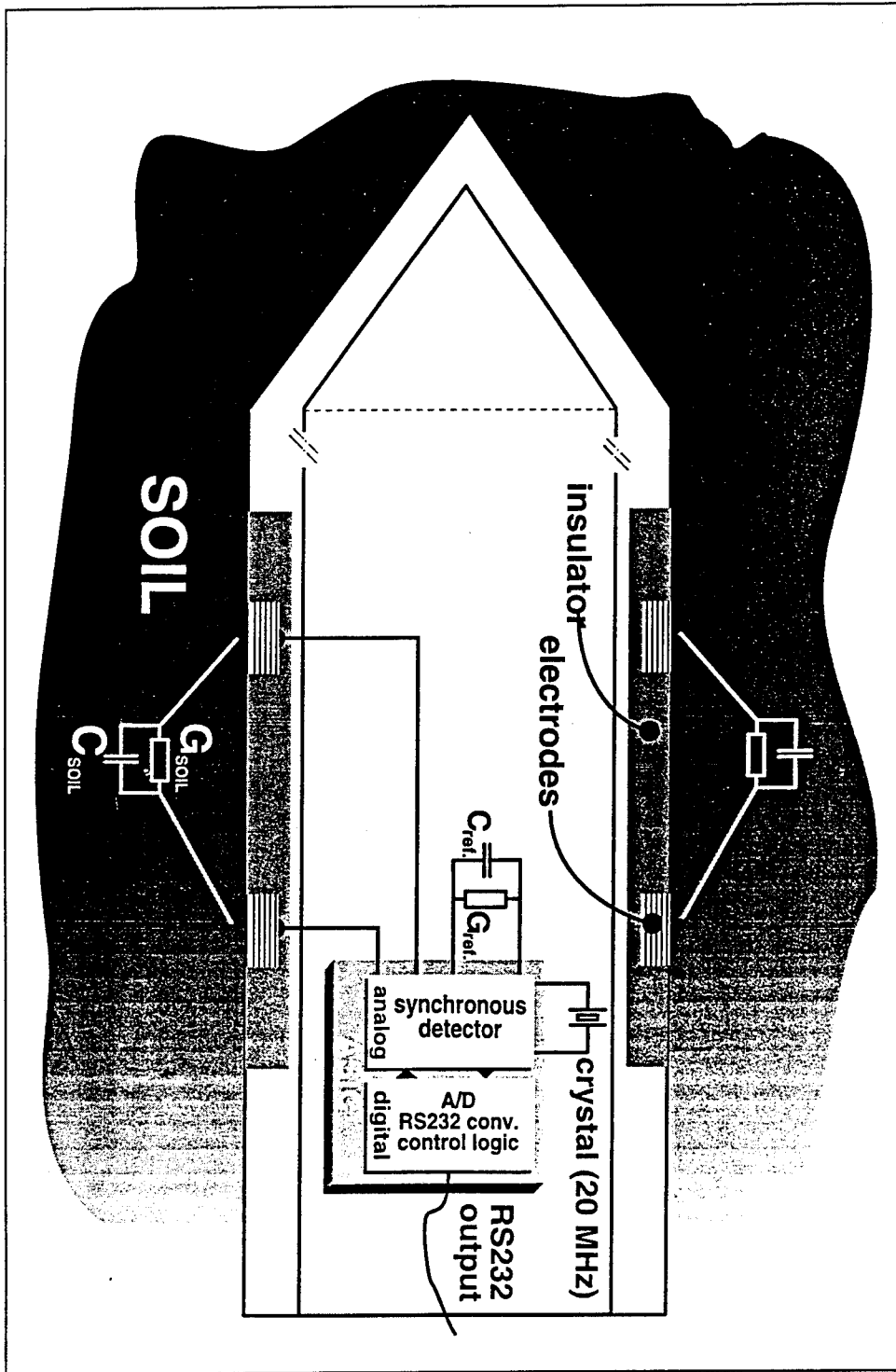

Figure 7. Schematic of a Dutch soil moisture device in a cone penetrometer (Hilhorst et al. 1995)

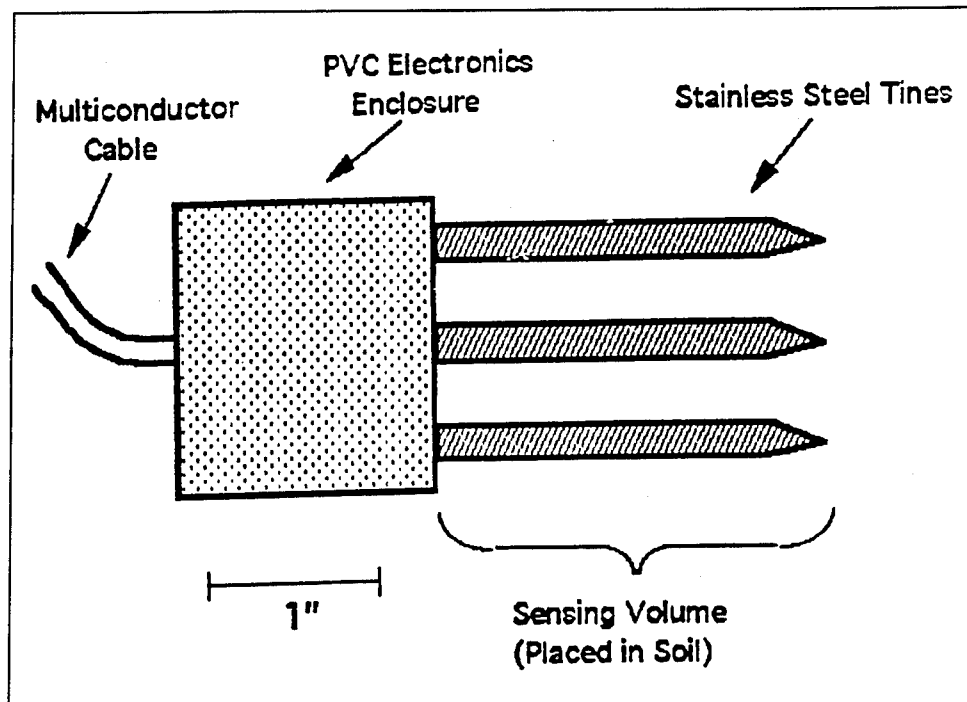

Figure 8. Schematic of a tined soil moisture probe (Vitel, Inc. 1994)

3 WES Prototype Sensor

Background

The rationale for pursuing the development of an effective electrical property measurement device at WES is at least twofold. First of all, in addition to the agricultural and horticultural needs for determining soil moisture content outlined in the Introduction, there is a definite military application for real-time measurement of soil moistures as they relate to vehicle mobility in the battlefield. What is needed is an ability to collect surface and near-surface moisture data with a portable device and to generate useful statistics of those data for well-defined areas of the battlefield. At the beginning of this study, no such capability existed.

The second potential application of such a technology is in the area of site characterization, particularly on military installations. WES is intensely involved in the development of a cone penetrometer system for use on Department of Defense sites that will help to not only characterize the geophysical parameters associated with the subsurface materials, but will also help map subsurface contamination in a cost-effective manner (Lee et al. 1993). While a low-frequency resistivity probe has already been added to the penetrometer to help define subsurface moisture conditions, there is strong evidence to believe that higher frequency microwave probes could provide extremely useful complementary profile data. Again, at the start of this study, the availability of the Dutch probe was not known (nor is its effectiveness known, even now).

An opportunity to take advantage of technology already developed at WES to help resolve these problems presented itself and is the subject of this report. For several years, WES was involved with the development of siting criteria for a perimeter security sensor system designed to detect human intruders. The basic principle of this system was that the human body, passing through the electromagnetic field generated by a "leaky" coaxial cable, would alter the field and generate a current in the line. The cable could be buried at the perimeter of a critical facility, and, through constant automated monitoring of the current in the line, provide a warning signal when its electromagnetic field is perturbed by an intruder.

Unfortunately, highly conductive soils such as moist clays attenuated the electric field lines (and the associated magnetic field lines) so severely that the coaxial sensor system could be rendered useless in such environments. WES needed an ability to easily and quickly determine the electrical properties of a potential intrusion detection sensor site, so that, if measurements so deemed, a less conductive soil could be backfilled around the coaxial cable. In particular, what was needed was a field-portable device capable of making in situ measurements of the dielectric constant and conductivity of the soil at the operating frequency of the leaky coaxial cable sensor (approximately 60 MHz). Since no such equipment was available on the commercial market, WES contracted Ohio State University to design and build a soil probe that would measure the desired properties. The result of the Ohio State effort was the DICON probe, so named because of its capability to measure the Dielectric constant and CONductivity of the soil (Caldecott, Poirier, and Svoboda 1985).

The original DICON probe and its associated electronics have been redesigned by WES to improve the durability, accuracy, and ease of use of the probe. While the basic design of the DICON probe should be easily adapted to a cone penetrometer geometry, the focus of the current effort is to develop a configuration that specifically addresses the need for making rapid surface soil moisture measurements.

Probe Geometry

The DICON probe required a test hole of 1.25 in. in diameter and approximately 12 in. deep. The hole was drilled using a soil auger. The latest redesign of the probe by WES, called the DCSR (Dielectric/Conductivity Surface Reflectometer) probe, eliminates the need for the test hole. The new probe has been configured to allow it to simply be pressed against the soil surface as shown in Figure 9 for a measurement of the near-surface electrical properties.

The DCSR probe consists of the probe head, the data processing circuitry, called the reflectometer, and a digital multimeter for display of intermediate data. The multimeter is mounted to the top of the reflectometer, which is connected to the probe head by a steel shaft. The probe head consists of two half-circle brass plates attached to an insulating body of Teflon with a small gap between the plates as illustrated in Figure 10. The brass plates form an external capacitor with the soil as the dielectric. The top of the Teflon body is screwed onto the steel shaft. The brass plates are connected to a 50-ohm coaxial cable that extends through the steel shaft into the reflectometer. Dimensions of the probe head are shown in Figure 11.

The reflectometer (Figure 12) is housed in a metal box attached to the top of the steel shaft. The reflectometer electronics consist of a power supply, metering circuit, signal source, probe circuitry, and two phase comparators.



Figure 9. DCSR system in use

Ohio State University report to WES (Caldecott, Poirier, and Svoboda 1985). The modifications that resulted in the DCSR were primarily changes to the geometry and improvement of the circuitry to make it more shock resistant.

Two external wires connect the reflectometer electronics to the voltmeter. The reflectometer box houses an R/I (real and imaginary) selector switch, a CHARGE/OFF/OPERATE selector switch, and a battery test button positioned adjacent to the voltmeter as shown in Figure 13.

Theory of Operations

A schematic diagram of the electronic circuitry for the DCSR reflectometer is shown in Figure 14. For a detailed description of how the reflectometer operates, particularly as to the rationale behind the selection of the balun transformer, one should refer to the original

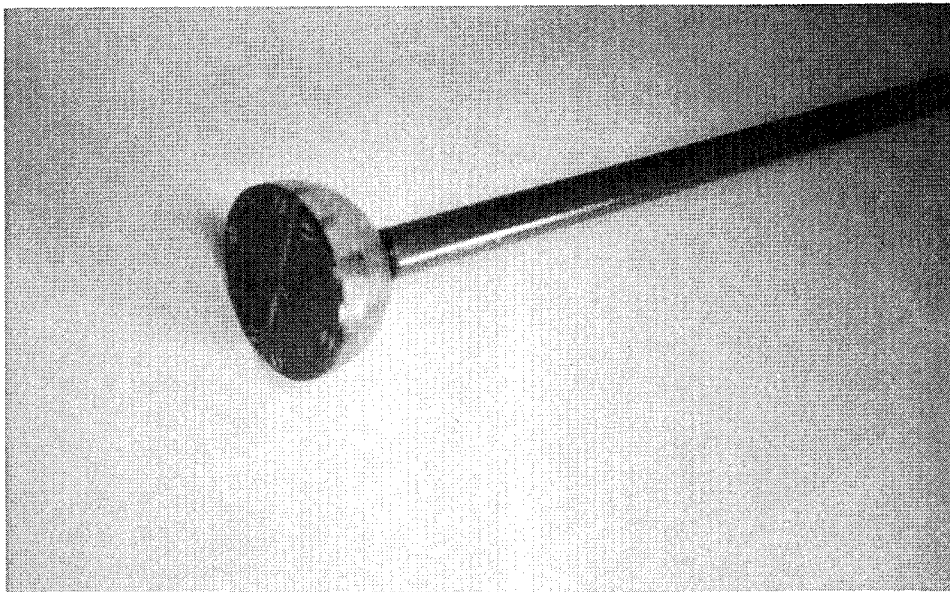

Figure 10. DCSR probe head

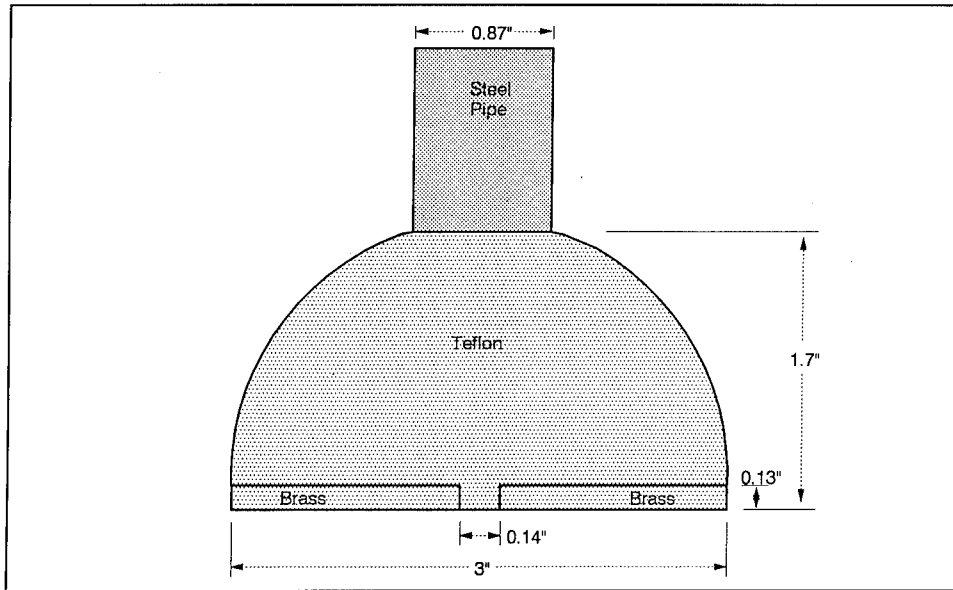

Figure 11. Dimensions of DCSR probe head

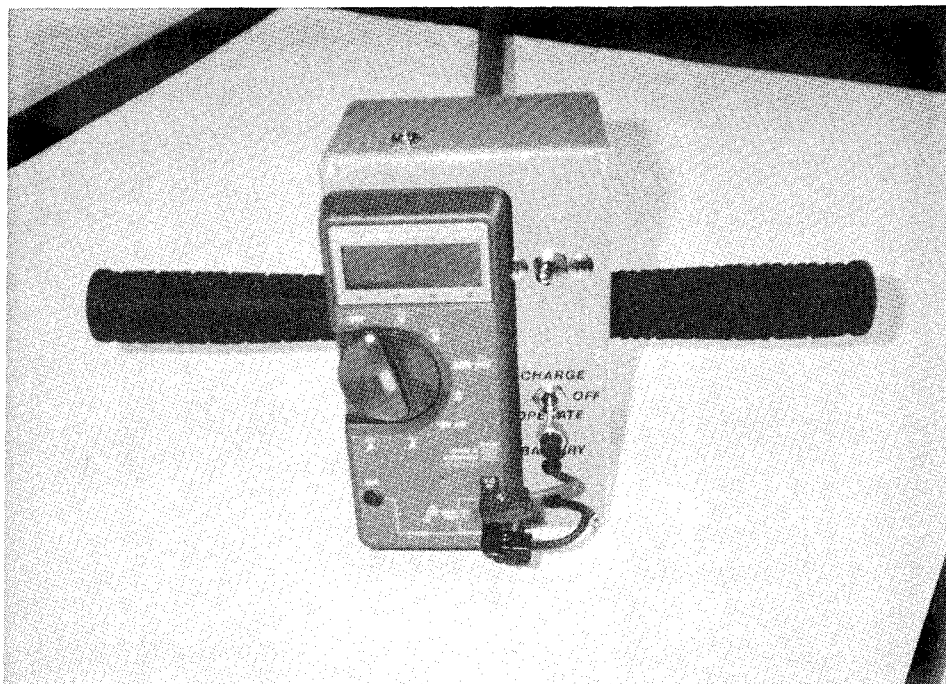

Figure 12. DCSR reflectometer box

Comments that follow are intended to justify the formulation of the model that follows and that is used to calculate the electrical properties of the soil.

The source within the reflectometer generates a sinusoidal signal that propagates the length of the coaxial cable within the steel shaft, is absorbed and reradiated from the medium (suffering a change in both amplitude and phase),

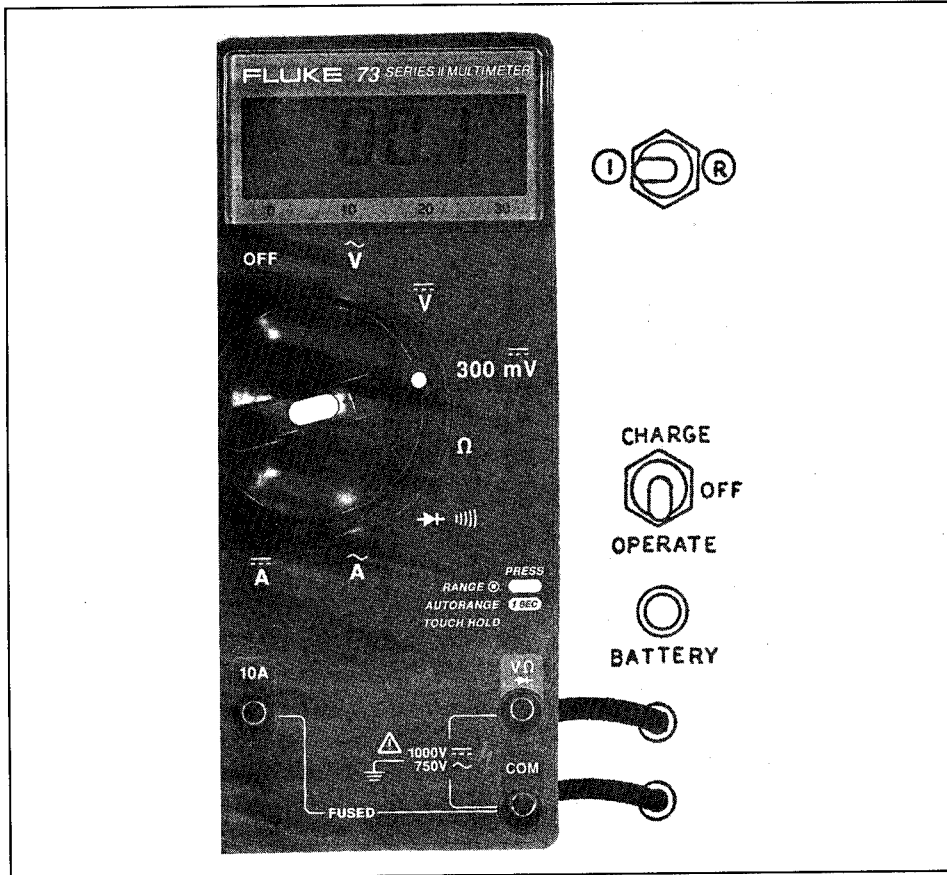

Figure 13. Switch configuration on DCSR box

and travels back along the cable to the detector portion of the reflectometer. The ratio of incident voltage to reflected voltage forms a complex voltage reflection coefficient, ρ .

Basic relationships

If one considers the coaxial cable to have a characteristic impedance, Z_0 , and the soil to be characterized by a complex impedance, Z , or its inverse, a complex admittance, Y , then the complex reflection coefficient and cable and soil properties are related by:

$$\rho = \frac{Z - Z_0}{Z + Z_0} = \frac{1 - Z_0 Y}{1 + Z_0 Y} \quad (8)$$

Conversely,

$$Y = G + jB = \frac{1}{Z_0} \left[\frac{1 - \rho}{1 + \rho} \right] \quad (9)$$

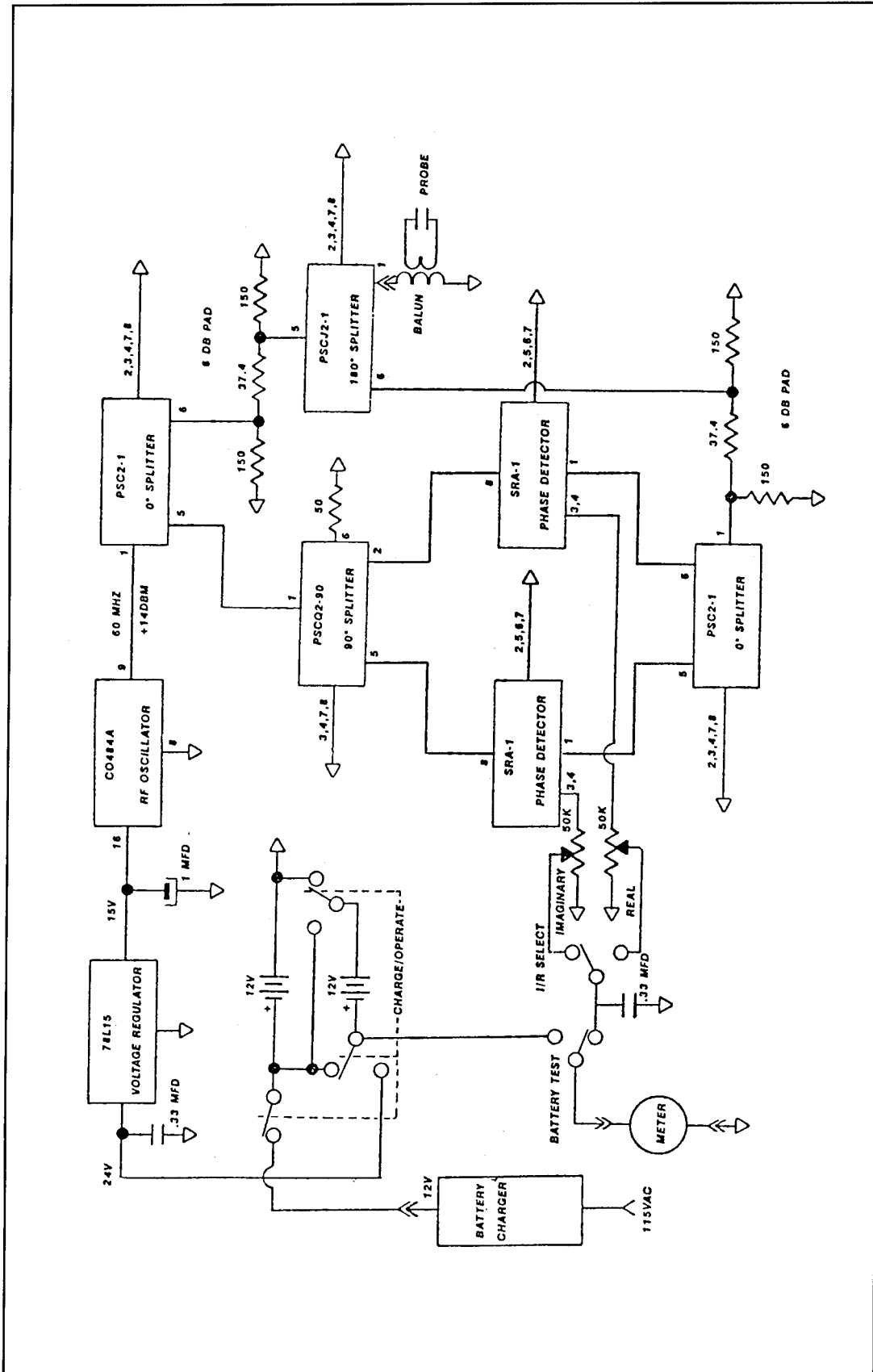

Figure 14. Schematic diagram of DCSR reflectometer

where

G = equivalent circuit conductance

B = equivalent circuit susceptance

The susceptance of an ideal capacitor is just the product of its capacitance and the radial frequency of the signal passing through it.

Consider, for a moment, a simplification of the geometry of this problem to that of an idealized parallel plate capacitor of area, A , and plate spacing, t , filled with a dielectric material whose relative permittivity is ϵ_r , and whose conductivity is σ . The capacitance of the device is

$$C = \frac{A\epsilon_r\epsilon_0}{t} \text{ farads} \quad (10)$$

where ϵ_0 is the permittivity of free space (8.85×10^{-12} farads/meter).

If this capacitor is an ideal 1-m cube, then A and t are both unity and the capacitance becomes

$$C = \epsilon_r\epsilon_0 \quad (11)$$

The capacitive susceptance is then

$$B = \omega C = 2\pi f\epsilon_r\epsilon_0 \quad (12)$$

where f is frequency in Hz. The conductance of this same capacitor is:

$$G = \sigma \quad (13)$$

Clearly, if one models the probe head as a capacitor and the soil as its dielectric filler, then a calculation of the complex admittance of the system through a measurement of its complex reflection coefficient will provide the soil conductivity from the equivalent circuit conductance and the soil permittivity from the equivalent circuit susceptance.

Model for DCSR probe

The probe consists essentially of two capacitors: an external one, for which the field lines pass through the soil or other external medium, and an internal one, in which the field lines pass through the Teflon support. The

latter capacitor has to be considered as invariant. Obviously, the DCSR probe head is not an ideal cubic meter parallel plate capacitor.

If, however, one can safely assume that the conductance and susceptance of the probe are proportional to that of the ideal capacitor, then one can rewrite the relationships for susceptance and conductance using a geometrical scale factor that accounts for the different geometry. Applying the above argument to the external capacitor and letting the external geometrical scale factor between the probe and the 1-m cube be α , the capacitive susceptance of the external portion of the probe is

$$B_e = \alpha 2\pi f \epsilon_r \epsilon_0 \quad (14)$$

and the external conductance is

$$G = \alpha \sigma \quad (15)$$

There is no internal conductance since the internal capacitor is essentially lossless. There is, however, an internal capacitive susceptance that is dependent on frequency but independent of the external permittivity. The internal capacitor will have its own geometrical scale factor, β' . Let this internal capacitive susceptance be

$$B_i = \beta' 2\pi f \epsilon_r \epsilon_0 = \beta f \quad (16)$$

From the above equations, the total admittance of the probe is simply:

$$G + j(B_e + B_i) = \alpha \sigma + j\alpha 2\pi f \epsilon_r \epsilon_0 + j\beta f \quad (17)$$

The quantities G and B ($B = B_e + B_i$) are readily obtained from a measurement of the reflection coefficient of the probe. All that is left is to evaluate the geometrical constants; i.e., calibrate the probe.

Probe calibration

The probe can be calibrated by measuring two lossless dielectrics, one of which may be air. In this case, G and σ are both zero. Let the measured susceptances in these two cases be B_1 and B_2 where

$$B_1 = \alpha 2\pi f \epsilon_{r_1} \epsilon_0 + \beta f \quad (18)$$

$$B_2 = \alpha 2\pi f \epsilon_{r_2} \epsilon_0 + \beta f \quad (19)$$

Solving for α and β yields

$$\alpha = \frac{B_1 - B_2}{2\pi f(\epsilon_{r_1} - \epsilon_{r_2})\epsilon_0} \quad (20)$$

$$\beta = \frac{B_2\epsilon_{r_1} - B_1\epsilon_{r_2}}{f(\epsilon_{r_1} - \epsilon_{r_2})} \quad (21)$$

It is convenient to use air as one of the dielectrics and a liquid whose properties are well known for the other (for example, methanol, which has a permittivity of 31 and negligible loss). The measured susceptances (B_1 and B_2) are obtained from the measured complex reflection coefficients in this lossless case using the equation

$$B = \text{Im} \left[\frac{(1 - \rho)}{Z_0(1 + \rho)} \right] \quad (22)$$

where ρ is the measured complex reflection coefficient obtained from the probe voltmeter, and Z_0 is the characteristic impedance on the probe side of the transformer, which is taken to be 200 ohms (4×50 ohms). *Im* denotes the imaginary component of the complex coefficient.

Ideally, the probe voltmeter R/I values would be the real and imaginary parts of the complex reflection coefficient. It does not matter, however, if the reflectometer introduces a phase rotation as long as the two outputs are orthogonal. Likewise, it does not matter if the meters have a range of exactly ± 1 (actually, they are adjusted to read approximately ± 100) provided they both have the same scale. Both these factors are taken care of by the short circuit calibration procedure (for which the voltage reflection coefficient is a real number equal to -1). If X_s and Y_s are the two voltmeter readings when the probe head is shorted and X and Y are the readings when it is measuring a soil sample, then the true complex reflection coefficient of that sample, referenced to 200 ohms at the location of the capacitor plates, is

$$\rho = - \frac{X + jY}{X_s + jY_s} \quad (23)$$

Soil measurements

When the probe head is placed against the medium whose electrical properties are desired (in this case moist soil), a complex reflection coefficient ρ measured. The complex admittance will be given by

$$G + jB = \frac{(1 - \rho)}{Z_0(1 + \rho)} \quad (24)$$

Equating the real and imaginary parts of this and the previous expression for the total probe admittance, one can solve for σ and ϵ_r :

$$\sigma = \frac{1}{Z_0 \alpha} \text{Re} \left[\frac{1 - \rho}{1 + \rho} \right] \quad (\text{V/m}) \quad (25)$$

$$\epsilon_r = \frac{1}{\alpha 2\pi f \epsilon_0} \left[\frac{1}{Z_0} \text{Im} \left[\frac{1 - \rho}{1 + \rho} \right] - \beta f \right] \quad (26)$$

where *Re* and *Im* denote selecting the real and imaginary parts, respectively, of the complex quantity in the square brackets.

The model developed in this section contains the general principles of how the DCSR probe and reflectometer operate. Detailed instructions regarding how to conduct calibrations and measurements are given in Appendix A.

At this point in time, the mode of operation for the probe/reflectometer system was to record the real and imaginary components of the complex voltage from each measurement (calibrations and real samples) and to calculate the permittivity and conductivity of each sample on a personal computer into which the above complex algebraic expressions had been programmed. As will be noted in the final chapter of this report, future improvements to the device would include a self-contained data storage and calculation capability.

4 Evaluation Measurements

Two sets of measurements were conducted with the DCSR probe and reflectometer to evaluate some of its operational constraints as well as its accuracy. One exercise involved experimentally establishing the effective zone of influence of the electric field lines that emanate from the probe head. These data provide an indication of the volume of material whose electrical properties would be measured by the probe and reflectometer. The other study involved measurements of electrical properties of two different soils at known various moisture contents and comparison of those data to data on the same soils collected in the laboratory using a coaxial reflection/transmission measurement device. The results of these measurements were quite encouraging and have led to the conclusion that further development of this device is clearly warranted.

Sample Volume Study

These experiments were performed to identify the volume of material through which the electric field lines from probe head penetrate during a measurement of electrical properties. Data were collected for measurements in air; thus, the zone of influence of the field lines is maximized. The methodology for testing involved controlled movement of the probe head toward conducting plates from three different directions as shown in Figure 15. More involved measurements in some real material such as soil could have been but were not warranted to provide an upper bound on the capabilities of this sensor package.

It was not necessary to perform calibration measurements for this study. All that was required was to observe how the real and imaginary numbers displayed by the voltmeter changed as the probe head approached the metal sheets from each direction. Figures 16-18 contain plots of the real and imaginary components (millivolts) recorded by the voltmeter as the probe head was moved toward the metal plate in each direction indicated in Figure 15. For the approach from the top, the plate was held close to the metal shaft, then lowered until it touched the Teflon probe head. From that point on, the plate remained in contact with the probe head until contact was made with the brass plate at the bottom.

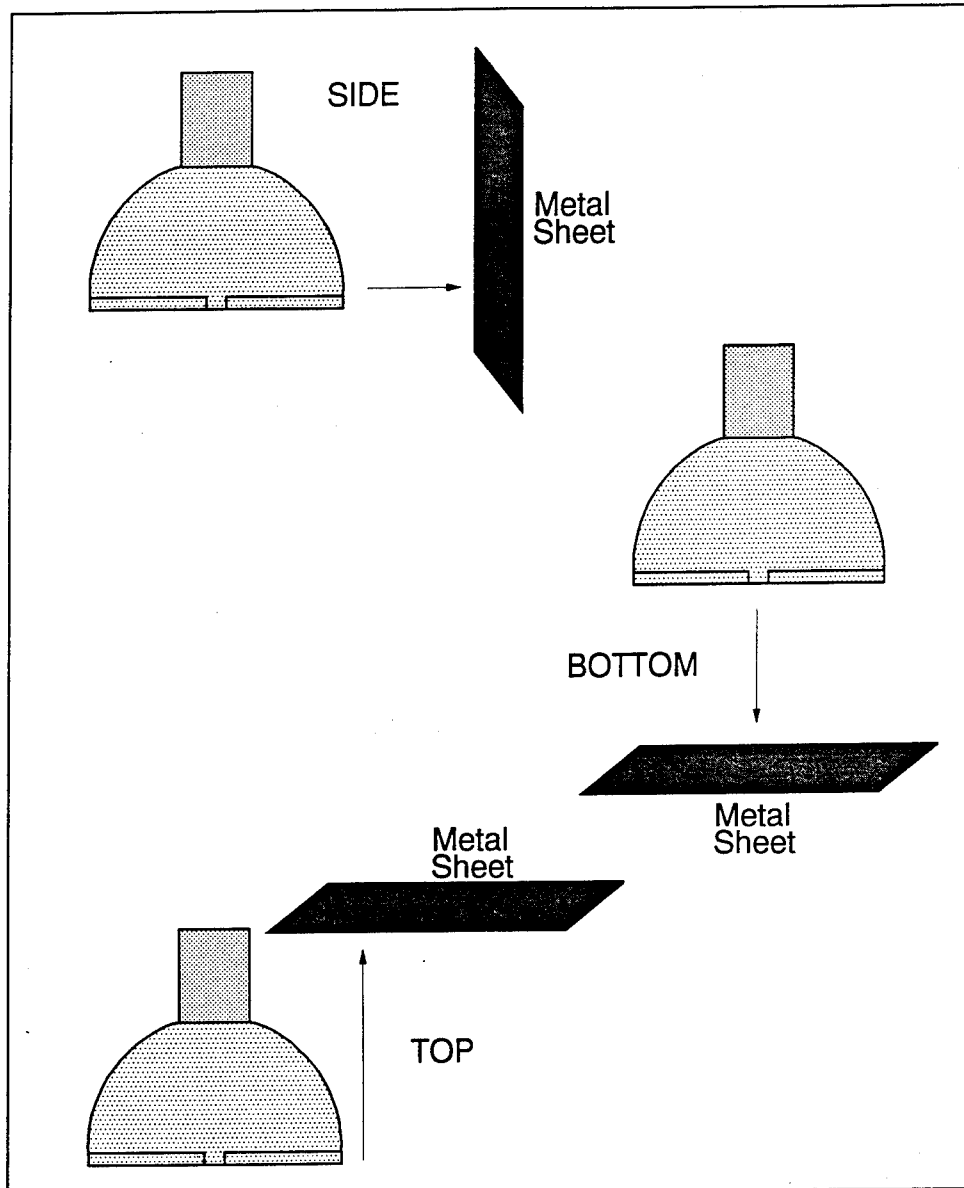

Figure 15. Zone of influence measurement methodology

Attention should be focused on Figure 17, which is the analog for measurements on flat surfaces such as an air/ground interface. One could easily argue that the maximum zone of influence beneath the probe head in air is something on the order of 2 to 3 cm. Assuming that field lines in a dielectric will be compressed by an amount proportional to the ratio of indices of refraction, then the DCSR probe should measure electrical properties within about the first centimeter of the dielectric surface.

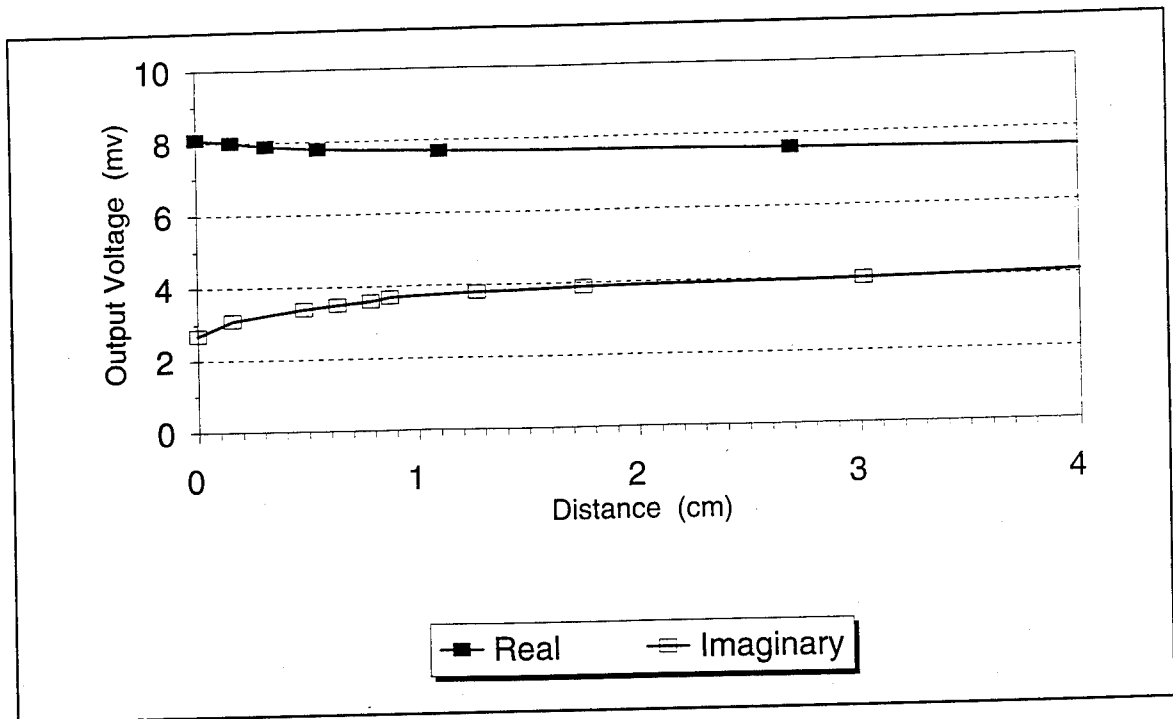

Figure 16. Voltmeter recordings versus distance from side

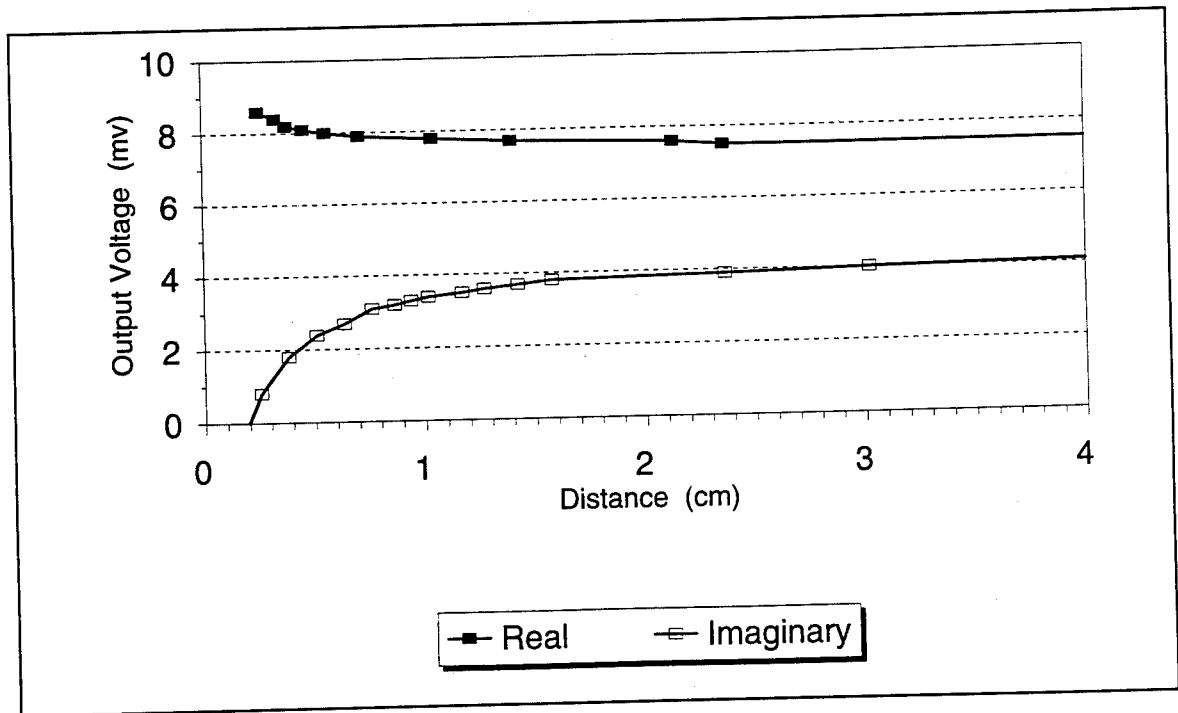

Figure 17. Voltmeter recordings versus distance from bottom

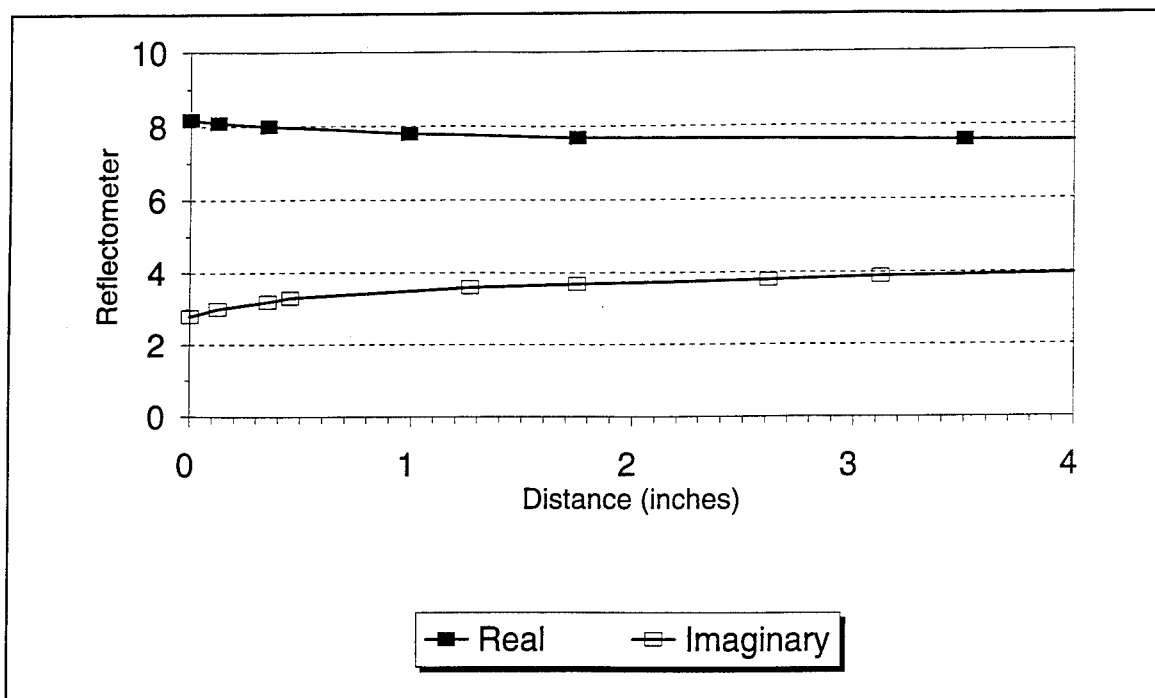

Figure 18. Voltmeter recordings versus distance from top

Initial Measurements on Real Materials

A second set of measurements were performed to evaluate both the accuracy of the probe and reflectometer and its repeatability. Using the calibration and measurement technique outlined in Appendix A, electrical property data were collected for five different materials (including those used for calibration); namely, distilled water, tap water, ethylene glycol, air, and methanol. The relative permittivities of these materials at room temperature (taken to be 25 °C) should be about 79, 79, 38, 1, and 33, respectively (Lucius et al. 1992). Conductivities should be close to, or equal to, zero for all of the measurements except for tap water (assuming that the distilled water is also deionized).¹ Results for these measurements are shown in Table 1.

The initial reaction to these data is one of concern, mostly because of the calculated conductivity values. In general, the permittivity measurements are quite good. Even the permittivity for ethylene glycol is not alarming because of the hygroscopic nature of glycol. Water absorbed from the air could easily account for its higher permittivity value.

¹ It was observed in the Introduction that conductivity becomes an important factor in the electrical response of materials whenever the term, $(\sigma/\epsilon\omega)^2$, is significantly different from zero, say, about 0.1. This would require that conductivity be greater than $0.32\epsilon\omega$. For this reflectometer and a soil whose relative permittivity might be on the order of 10, conductivities greater than 10 mmhos/m would be considered significant.

Table 1 Initial Measurements				
Calibration Item	Reflectometer Voltages, mV		Relative Dielectric	Conductivity, mmhos/m
	Real	Imaginary		
Short	-2.2	-9.5		
Air	7.5	4.1		
Methanol	2.7	-9.2		
Test Substance			Relative Dielectric	Conductivity, mmhos/m
Distilled Water	0.0	-9.8	82	-6
Tap Water	0.0	-9.6	82	20
Ethylene Glycol	1.9	-9.4	42	6
Air	7.5	4.1	1	3
Methanol	2.7	-9.2	34	4

Unsatisfactory conductivity values generated a closer examination of how these numbers are calculated. It turns out that both permittivity and conductivity are quite sensitive to the voltage values measured by the reflectometer circuitry. For example, consider the artificial set of calculations for distilled water presented in Table 2. What can clearly be seen is that the calculated permittivity for water is sensitive to the real part of the complex voltage measurement; a variation in the real part of the voltage of 0.14 mV resulted in a 5-unit change in calculated relative permittivity. At the same time, the conductivity was found to be highly sensitive to the imaginary part of the complex voltage; a variation in the imaginary part of the voltage of 0.14 mV resulted in a variation in calculated conductivity of 15 mmhos/m.

Obviously, with a voltmeter capable of displaying only tenths of a millivolt, one has to question the accuracy of the device; however, one also has to be encouraged by these results. If the precision of the voltmeter readings can be improved, and if the accuracy of the voltmeter can be believed, then it seems highly likely that a probe and reflectometer can be fabricated that would be capable of accurately measuring the electrical properties of low-conductivity materials. Naturally, this will be offered as a recommendation for future studies.

Soil Measurements

If a simple relationship existed between the electrical properties of materials such as fine-grained soils and the amount of water contained in the material, then one of the obvious applications for a portable electrical property measurement device such as this probe and reflectometer would be as a

**Table 2
Voltmeter Sensitivity Studies**

Calibration Item	Reflectometer Voltages, mV		Relative Dielectric	Conductivity, mmhos/m
	Real	Imaginary		
Short	-2.2	-9.4		
Air	7.4	4.1		
Methanol	2.8	-9.2		
Test Substance				
Distilled Water	0.0	-9.7	76	-6
	0.02	-9.7	75	-5
	0.04	-9.7	75	-5
	0.06	-9.7	74	-5
	0.08	-9.7	73	-5
	0.10	-9.7	73	-5
	0.12	-9.7	72	-5
	0.14	-9.7	71	-5
	0.10	-9.56	73	10
	0.10	-9.58	73	8
	0.10	-9.60	73	6
	0.10	-9.62	73	4
	0.10	-9.64	73	1
	0.10	-9.66	73	-1
	0.10	-9.68	73	-3
0.10	-9.70	73	-5	

moisture content probe. Recent research has indicated that there is such a simple relationship for a wide variety of soil types (Curtis, Weiss, and Everett, In Preparation).

In fact, a plot of the results of laboratory measurements on 12 different soils is shown on Figure 19 (Appendix B contains a complete set of electrical property data at 60 MHz). Also included on that figure are three different empirical models that might be used to predict volumetric soil moisture from a measurement of the permittivity of the soil. The model attributed to this study is limited to moistures less than 36 percent by volume. This restriction was chosen to provide the best fit to data over the most useful range of moisture values. A model for the entire range of frequencies could have been easily derived at the expense of accuracy on the lower end of the moisture spectrum.

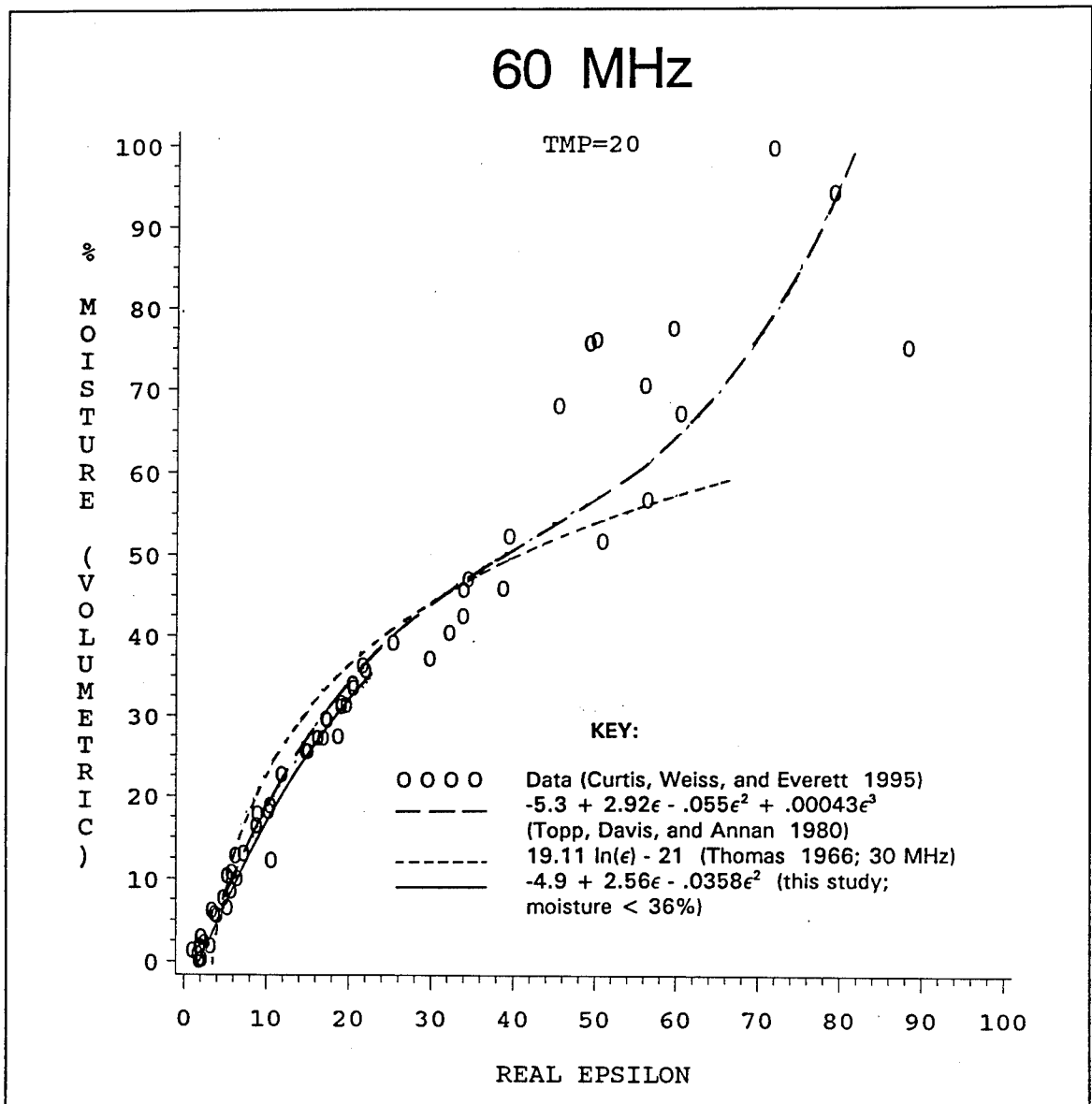

Figure 19. Laboratory data (Curtis, Weiss, and Everett, In Preparation) and empirical models for soil permittivity versus volumetric moisture

As a test of the potential of the DCSR to function as a soil moisture meter, another series of probe and reflectometer measurements were conducted on two of the soils referenced above. Soil #1 was a poorly graded clean sand, and soil #2 was also a sand, but one that contained some finer grained particles. The experimental technique was to fill a nonconducting container (large enough, at any rate, to eliminate interference from the walls of the container) with the so-called dry soil,¹ make a measurement, add a known quantity of

¹ Even "dry" soils at ambient conditions contain 1- or 2-percent moisture by volume.

water to the soil, make another measurement, and repeat until the soil was nearly saturated. The "dry" density of each sample was 1.68 g/cc.

Probe measurements and the calculated dielectric constant and conductivity are shown in Table 3. As a check on the accuracy of the DCSR permittivity data, they are plotted on Figures 20 and 21 along with interpolated results measured by an HP 8510C Network Analyzer system at an earlier date (Curtis, Weiss, and Everett, In Preparation). These results are quite encouraging, particularly in light of the voltmeter sensitivity issue discussed above.

Table 3 Soil Measurements					
Calibration Item		Reflectometer Voltages, mV			
		Real	Imaginary		
Short		-2.2	-9.4		
Air		7.5	4.0		
Methanol		2.6	-9.2		
Test Substance	Volumetric Moisture			Relative Dielectric	Conductivity mmhos/m
Dry Soil #1	~0.0%	8.4	1.8	3	3
+ 100 ml H ₂ O	7.9	8.5	-1.1	5	3
+ 200 ml H ₂ O	15.7	6.9	-6.1	13	3
+ 300 ml H ₂ O	23.6	6.0	-7.2	16	2
+ 400 ml H ₂ O	31.4	6.0	-7.2	16	2
+ 500 ml H ₂ O	39.3	4.3	-8.5	23	2
Dry Soil #2	~0.0	8.4	1.6	3	3
+ 100 ml H ₂ O	7.9	8.1	-2.9	7	4
+ 200 ml H ₂ O	15.7	6.5	-6.4	14	4
+ 300 ml H ₂ O	23.6	6.4	-6.6	14	3
+ 400 ml H ₂ O	31.4	5.0	-7.9	20	3
+ 500 ml H ₂ O	39.3	4.6	-8.2	21	3

Repeated Measurements

Although the question of measurement accuracy, and in some ways, measurement repeatability, has already been addressed, one additional set of data were collected with the DCSR on the original nonsoil materials referred to in Table 1. These results are shown in Table 4 and, given the comments made previously on voltmeter sensitivity, are quite acceptable.

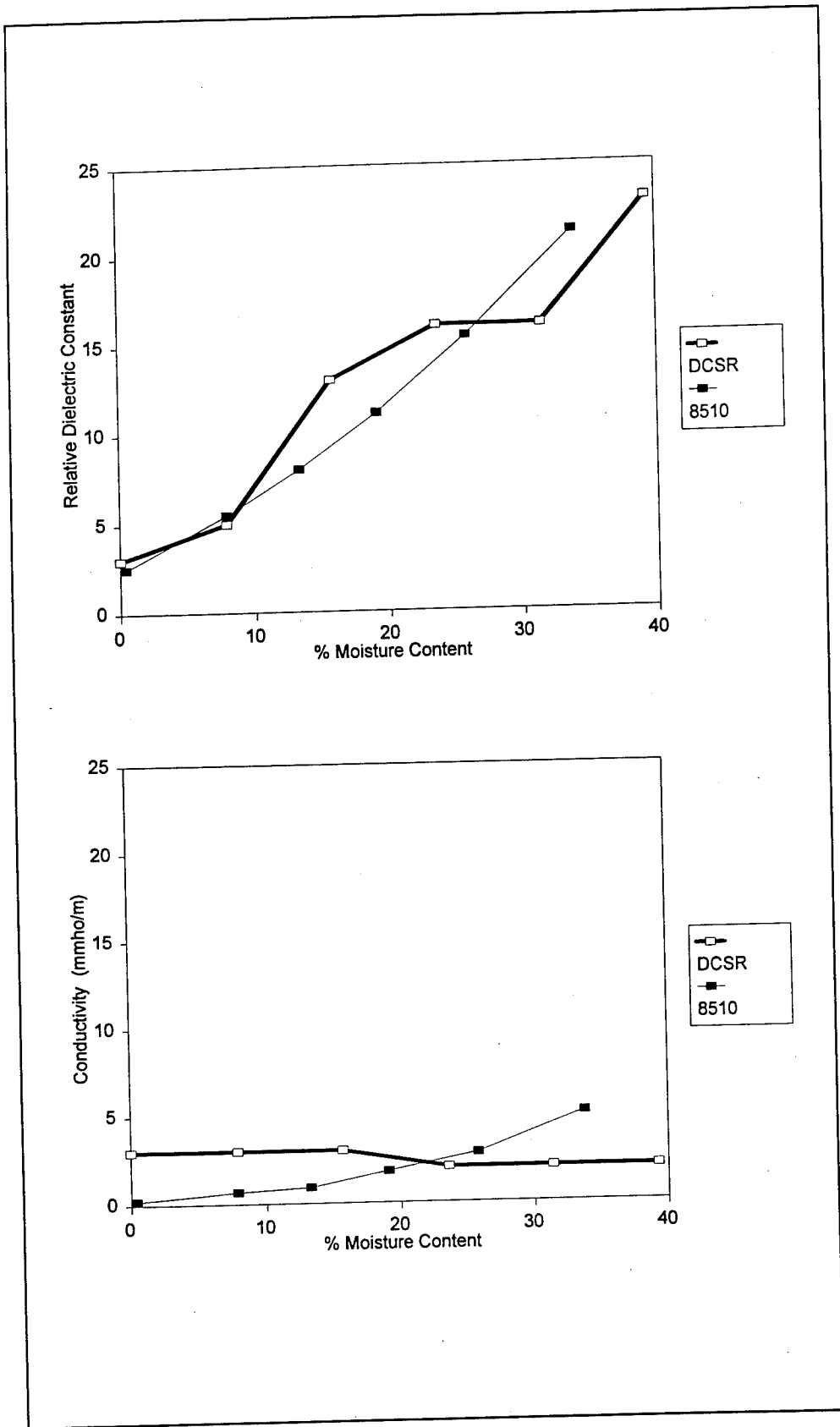

Figure 20. DCSR and other laboratory data for soil #1

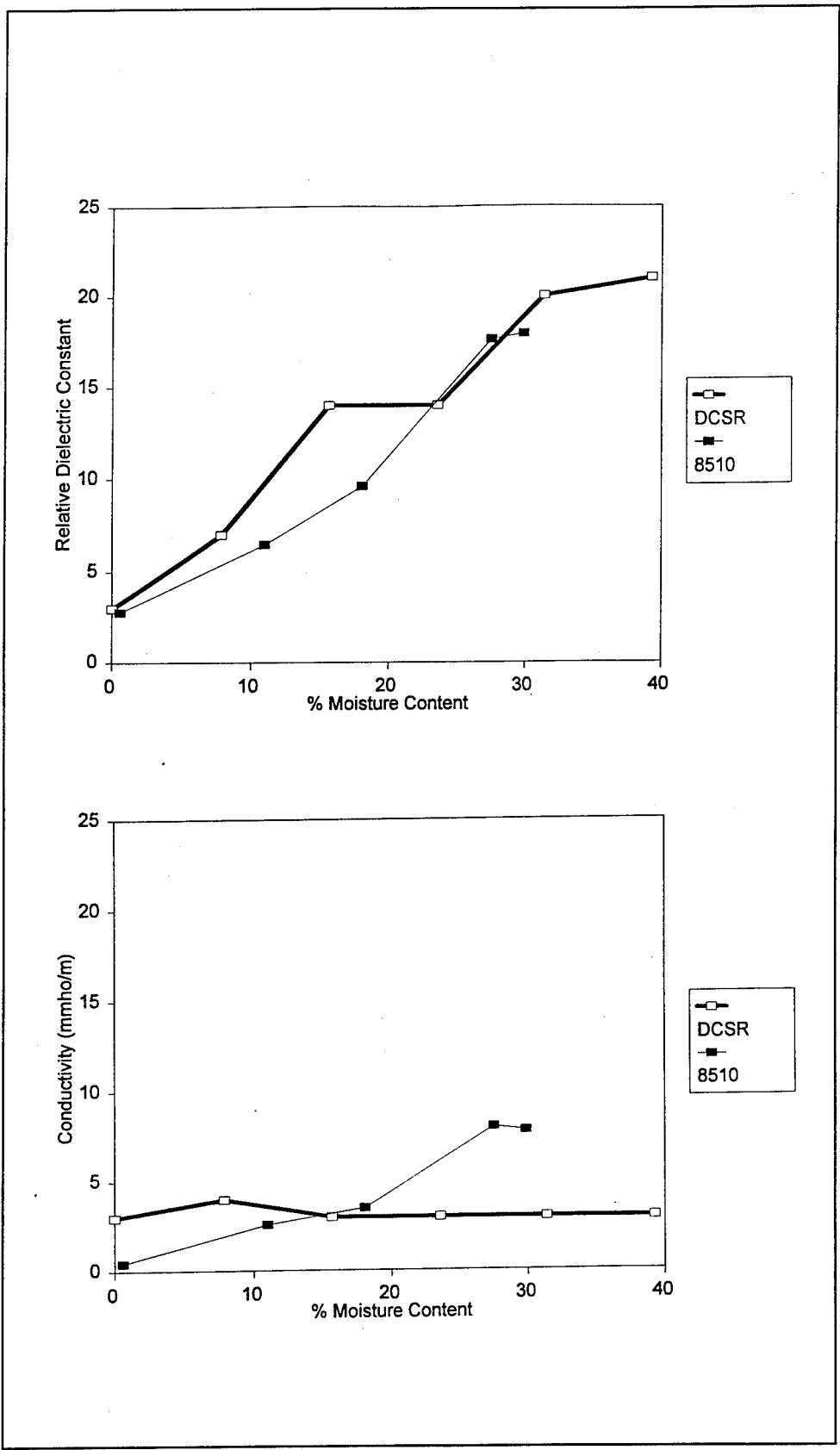

Figure 21. DCSR and other laboratory data for soil #2

Table 4 Nonsoil Measurements (Repeated)				
Calibration Item	Reflectometer Voltages, mV			
	Real	Imaginary		
Short	-2.2	-9.4		
Air	7.5	4.0		
Methanol	2.6	-9.2		
Test Substance			Relative Dielectric	Conductivity mmhos/m
Distilled Water	0.0	-9.7	80	-6
Tap Water	0.0	-9.6	82	7
Ethylene Glycol	1.8	-9.4	42	3
Air	7.5	4.0	1	2
Methanol	2.6	-9.2	34	3

5 Future Improvements and Applications

At least four different areas of research can be envisioned for future studies related to the DCSR device. Some deal with accuracy issues, and some deal with making the device more “user friendly.” These topics are summarized in the following paragraphs:

- a.* A careful analysis of the circuitry used in the reflectometer should be conducted to assess the accuracy of the complex voltage measurements. If the device is capable of measuring complex voltages to hundredths of a millivolt, then a voltmeter capable of making and displaying such measurements should be substituted for the current equipment. The objective of this study is to develop a device capable of accurately measuring the electrical properties of low-conductivity materials.
- b.* A microprocessor capable of storing complex voltage measurements and instantly calculating permittivities and conductivities needs to be added to the reflectometer. The processor should also be capable of producing statistics such as means and variances for large amounts of data being collected on presumed uniform materials. These features would make the DCSR more user friendly as an electrical property measurement device.
- c.* Assuming that the microprocessor feature had been added, the empirical relationship between relative permittivity and soil moisture should be added to the package to develop a portable, real-time, soil moisture measurement device. The statistics feature would provide useful data for measurements made over large patches of terrain.
- d.* A study should be undertaken to incorporate this technology (after the other items have been dealt with) into a cone penetrometer geometry, where it could function as one of a suite of sensors used to characterize subsurface conditions at both military and civilian test sites.

References

- Arcone, S. A., and Larson, R. W. (1988). "Single-horn reflectometry for in situ dielectric measurements at microwave frequencies," *IEEE Transactions on Geoscience and Remote Sensing* 26(1), 89-93.
- Arulanandan, K. (1980). "Method and apparatus for measuring in situ density and fabric of soils," United States Patent No. 4,219,776.
- Arulanandan, K., and Arulanandan, S. (1987). "Dielectric methods and apparatus for in situ prediction of porosity and specific surface area (i.e., soil type) and for detection of hydrocarbons, hazardous waste materials, and the degree of melting of ice and to predict in situ stress-strain behavior," United States Patent No. 4,654,598.
- Bose, T. K., Bottreau, A. M., and Chahine, R. (1986). "Development of a dipole probe for the study of dielectric properties of biological substances in radiofrequency and microwave region with time-domain reflectometry," *IEEE Transactions on Instrumentation and Measurement* IM-35(1), 56-60.
- Brunfeldt, D. R. (1987). "Theory and design of a field-portable dielectric measurement system," *Proceedings of IGARSS '87 Symposium*. Ann Arbor, MI, 559-63.
- Burdette, E. C., Cain, F. L., and Seals, J. (1980). "In vivo probe measurement technique for determining dielectric properties at VHF through microwave frequencies," *IEEE Transactions on Microwave Theory and Techniques* MTT-28(4), 414-27.
- Caldecott, R., Poirier, M., and Svoboda, D. E. (1985). "A radio frequency probe to measure soil electrical parameters," Final Contract Report 715 616-4, U.S. Army Engineer Waterways Experiment Station, Vicksburg, MS.
- Campbell, J. (1988). "Dielectric properties of moist soils at RF and microwave frequencies," Ph.D. diss., Dartmouth College, Hanover, NH.

- Commonwealth Scientific and Industrial Research Organization. (1974). "Testing timber for moisture content," Division of Building Research Special Report, Melbourne, Australia.
- Curtis, J. O., Weiss, C. A., and Everett, J. B. (1995). "Effect of soil composition on complex dielectric properties," Technical Report in preparation, U.S. Army Engineer Waterways Experiment Station, Vicksburg, MS.
- Gabriel, C., Grant, E. H., and Young, I. R. (1986). "Use of time domain spectroscopy for measuring dielectric properties with a coaxial probe," *J. Phys. E: Sci. Instrum.* 19, 843-46.
- Griffiths, D. J. (1981). *Introduction to electrodynamics*. Prentice-Hall, Inc., Englewood Cliffs, NJ.
- Hilhorst, M. A., Pluimgraaff, J. M. H., de Reuver, H. J., and Mosterd, R. (1995). "Development and use of the soil moisture probe," Geomet Holding, Sassenheim, The Netherlands.
- Jackson, T. J. (1990). "Laboratory evaluation of a field-portable dielectric/soil-moisture probe," *IEEE Transactions on Geoscience and Remote Sensing* 28(2), 241-45.
- Lawrence, F. (1989). "Manual for portable dielectric probe," Applied Microwave Corporation, Lawrence, KS.
- Lee, L. T., Chrestman, A. M., Powell, J. F., and Malone, P. G. (1993). "Site investigations with the site characterization and analysis penetrometer system at Fort Dix, New Jersey," Technical Report GL-93-17, U.S. Army Engineer Waterways Experiment Station, Vicksburg, MS.
- Lucius, J. E., Olhoeft, G. R., Hill, P. L., and Duke, S. K. (1992). "Properties and hazards of 108 selected substances - 1992 Edition," U.S. Geological Survey, Open-File Report 92-527, Golden, CO.
- Olson, S. C., and Iskander, M. F. (1986). "A new in situ procedure for measuring the dielectric properties of low permittivity materials," *IEEE Transactions on Instrumentation and Measurement* IM-35(1), 2-6.
- Parchomchuk, P., Wallender, W. W., and King, R. J. (1990). "Calibration of a waveguide sensor for measuring soil moisture," *IEEE Transactions on Geoscience and Remote Sensing* 28(5), 873-78.
- Thomas, A. M. (1966). "In situ measurement of moisture in soil and similar substances by 'fringe' capacitance," *J. Phys. E: Sci. Instrum.* 43, 21-7.

Topp, G. C., Davis, J. L., and Annan, A. P. (1980). "Electromagnetic determination of soil water content: Measurements in coaxial transmission lines," *Water Resources Research* 16(3), 574-82.

Troxler Electronics Laboratories, Inc. (1994). Sales literature on the Sentry 200 Moisture Probe, Research Triangle Park, NC.

Vitel, Inc. (1994). "Vitel soil moisture probe," Chantilly, VA.

Appendix A

Operations Guide for DCSR Probe and Reflectometer

Reasonable measurements of electrical properties can be obtained only if the established procedure for using the DCSR probe is followed. Proper use of the probe involves the following steps: battery test, calibration, soil measurements, and calculation of the dielectric constant and conductivity. Test measurements performed with the probe and results of calculations are discussed in the body of the report.

Battery Test

Before probe measurements are taken, the batteries in the reflectometer must be tested by placing the reflectometer CHARGE/OFF/OPERATE selector switch in the OPERATE position, rotating the voltmeter selector dial to the DC volts scale (V), and then depressing the BATTERY button on the reflectometer. While the BATTERY button is depressed, the voltmeter reading should be between 24.0 and 26.0 V for practical probe measurements. If the voltage is less than 24.0 V, the probe batteries must be charged before reliable soil measurements can be taken.

The battery test procedure should be performed just prior to taking the calibration measurement and again every 2 to 3 hr while taking soil measurements. A 15-min warm-up period in the OPERATE mode is suggested to allow the battery and electronics to stabilize. It is also recommended that a preliminary battery test also be done a few hours before soil measurements are scheduled to be taken to allow sufficient time for charging the batteries if they are weak.

If the probe batteries are weak, they may be charged with the 12-V Gel Cel battery charger provided as part of the DCSR probe equipment package. The power cord coming out of the battery charger plugs into the appropriate connector on the side of the reflectometer box for charging. The CHARGE/OFF/OPERATE selector switch on the reflectometer should be in the

CHARGE position. The battery-test procedure should be performed no sooner than 15 min after the probe has been disconnected from the battery charger to allow the battery voltage to stabilize before values are obtained from the battery.

Reflectometer Controls

Before the DCSR probe is actually used, the procedures for preparing it for operation and obtaining data must be understood. The probe may be prepared for operation by placing the reflectometer CHARGE/OFF/OPERATE selector switch in the OPERATE position and then rotating the voltmeter selector dial to the 300 mV scale. The values provided by the voltmeter are the real and imaginary (R/I) components of the reflection coefficient, both of which are used in the calculation of the dielectric constant and conductivity. For each measurement made with the probe (both calibration and soil measurements), R/I values should be recorded on log sheets similar to the one shown in the tables in Chapter 4. The real value is obtained by placing the R/I switch on the reflectometer in the R position and recording the voltmeter reading. Similarly, the imaginary value is obtained with the R/I switch in the I position. The R/I values should be between -10.0 and +10.0 mV.

The probe may be turned off by placing the CHARGE/OFF/OPERATE selector switch in the OFF position and then rotating the voltmeter selector dial to the OFF position.

Calibration Procedure

Before making soil measurements with the DCSR probe, a calibration measurement must be obtained by making three different measurements. For each measurement, the R/I readings must be recorded. The procedure for taking these readings is presented in the following paragraphs.

Short

The first of the calibration measurement is taken with the brass plates on the probe head shorted together. The most effective way of shorting the brass plates is to place multiple layers of aluminum foil on a hard flat surface and press the probe head brass plates onto the aluminum foil. The brass plates should be cleaned with a dry cloth to ensure that residual soil particles do not prevent the aluminum foil from making good contact with the plates. The R/I readings should be recorded.

Air

The next calibration measurement is taken with the probe head in air. While taking the air measurement, the probe head must be at least 1 ft away from any surrounding objects to ensure that the measurement is not influenced by other materials. If the probe head was cleaned properly prior to taking the short measurement, it should be free of any residue or moisture that could alter the air measurement. The R/I readings should be recorded.

Methanol

The final calibration measurement is taken with the probe head immersed in a nonmetallic container filled with methanol. A clear plastic cylindrical container approximately 6 in. in diameter filled with approximately 6 in. of methanol is ideally suited for this purpose. While making this measurement, the brass plates should be just below the surface of the methanol. The probe head should also be kept as close to the center of the container as possible to prevent interference from the container side walls. To prevent methanol from seeping in around the brass plates, the probe head should be immersed in the methanol no longer than 15 sec and removed immediately after the R/I readings are recorded. After the probe head is removed from the methanol, it must first be dried with a towel and then allowed to air-dry for at least 5 min before continuing with measurements.

Air check

The next step is another air measurement (same as above) to verify minimum methanol seepage into the probe head. This measurement should be identical to the air measurement above. If the R/I values differ, then again dry probe head with towel and air-dry until the air measurement is the same as the above air measurement.

Examination of calibration data

After the short, air, and methanol calibration measurements are completed, they should be carefully examined to ensure that the three pairs of R/I values are not the same. A properly functioning probe should give different readings for the three calibration steps. If the readings are essentially the same, the most likely cause of the problem is a poor solder connection at the impedance matching transformer mounted on top of the Teflon probe head. This situation must be corrected and the calibration procedure repeated before soil measurements can be performed.

Frequency of calibration procedure

The calibration procedure described previously should certainly be done at the beginning of each day prior to making any soil measurements. However, it is also recommended that the calibration procedure be repeated at the end of the day after all soil measurements have been collected. This calibration measurement would be expected to vary slightly (± 0.3 mV) due to changes in temperature, humidity, and other environmental factors that may affect the reflectometer electronics.

Calibration checks

In addition to performing the complete calibration procedure at the beginning and end of each day, a calibration check should be performed before each individual soil measurement is made. The reason for checking the calibration is to make sure that the probe is functioning properly and to see if recalibration is required due to changes in temperature or other factors. A calibration check can be done by making an air measurement. The procedure for obtaining the air measurement is described above. If a significant variation (± 0.3 mV from the air readings obtained at the beginning of the day) in the R/I readings is observed at any time during the day, the entire calibration procedure should be repeated at that time. A large change (> 1.0 mV) in the R/I reading indicates possible problems with the probe solder connections.

Soil Measurements

The radio frequency (RF) field of the DCSR probe radiates approximately 3 cm from any point on the brass plates. An illustration of this is shown in Figure 7. On each soil measurement, the test area should be a relatively flat surface of approximately 15 cm in diameter and a depth greater than 3 cm. The RF field will not radiate beyond this area with the probe head placed near the center.

Measurements can be performed by placing the reflectometer into the OPERATE mode and the voltmeter selector dial to the 300-mV scale. The R/I values given by the voltmeter for each measurement should be recorded. If poor contact is suspected between the brass plates on the probe head and the test surface, the probe should be lifted and turned 180 deg for another measurement. If the R/I values are not essentially constant (± 0.2 mV), a new test surface should be prepared to ensure that good contact is maintained during the measurement.

Calculation of Dielectric Constant and Conductivity

Since the actual calculation of the dielectric constant and conductivity from the DCSR probe measurements is quite involved and time-consuming when done by hand, it is recommended that a hand-held programmable calculator be used to do these calculations. What follows is a description of how such calculators have been used in past studies at WES when the original DICON probes were being utilized for electrical property measurements in the field. A similar approach might be taken for the DCSR device, or one might attach to it a microprocessor that would reduce data collection to a single pull of a trigger.

Before any calculator can be used, the two programs that perform the soil electrical properties calculations must be entered into the calculator's memory. The programming steps for these programs ("CAL" and "SOILS") for a Hewlett-Packard HP-42S programmable calculator are shown on the following pages. An HP-42S owner's manual should be referenced to obtain detailed information on how to enter the programming steps into memory. After the programs are initially entered, they will remain in the continuous memory even when the calculator power is turned off. The test data provided in any of the tables in Chapter 4 could be used to test the program to verify the steps were keyed in correctly. If incorrect values of dielectric constant and conductivity for the test data are calculated by the programs, the program steps resident in memory for "CAL" and "SOIL" should be checked for errors.

Once "CAL" and "SOIL" are programmed into the calculator, soil dielectric constant and conductivity calculations may be done by simply executing "CAL" and entering the calibration data and then executing "SOIL" and entering the soil data. The user will be prompted by the calculator for all input data. "CAL" need only be executed once for a given set of calibration data. If calibration measurements were taken both before and after the soil measurements were made, the average of the two measurements should be used in "CAL." After each soil measurement is entered, "SOIL" will calculate and display the dielectric constant and conductivity of the soil. The soil dielectric constant and conductivity should be calculated in the field immediately after each probe measurement is made and then recorded in a log book next to the corresponding R/I values. Since dielectric constant and conductivity values are positive real numbers, negative values of dielectric constant and/or conductivity given by the calculator programs indicate that either a mistake was made in keying in the input data or the probe is not functioning properly.

It should be noted that any programmable calculator or computer with sufficient memory can be used to do the dielectric constant and conductivity calculations. The principal advantage of using a small battery-powered calculator such as the HP-42S, however, is that the dielectric constant and conductivity of the soil can be calculated quickly and conveniently in the field as the DCSR probe measurements are taken. The "CAL" and "SOIL" programs for

the HP-42S were originally developed for the HP-41CV/CX series calculators, which use essentially the same programming steps as the HP-42S.

"CAL" Program Listing

01 ♦ LBL "CAL"	52 RCL 10
02 "R OFFSET=?"	53 -
03 PROMPT	54 X↑2
04 STO 20	55 +
05 "I OFFSET=?"	56 100
06 PROMPT	57 *
07 STO 21	58 /
08 "R SHORT=?"	59 STO 14
09 PROMPT	60 RCL 03
10 RCL 20	61 RCL 12
11 +	62 *
12 STO 03	63 RCL 04
13 "I SHORT=?"	64 RCL 11
14 PROMPT	65 *
15 RCL 21	66 -
16 +	67 RCL 03
17 STO 04	68 RCL 11
18 "R AIR=?"	69 -
19 PROMPT	70 X↑2
20 RCL 20	71 RCL 04
21 +	72 RCL 12
22 STO 09	73 -
23 "I AIR=?"	74 X↑2
24 PROMPT	75 +
25 RCL 21	76 100
26 +	77 *
27 STO 10	78 /
28 "R METH=?"	79 STO 15
29 PROMPT	80 CHS
30 RCL 20	81 RCL 14
31 +	82 +
32 STO 11	83 300
33 "I METH=?"	84 *
34 PROMPT	85 1
35 RCL 21	86 RCL 13
36 +	87 -
37 STO 12	88 /
38 31	89 STO 07
39 STO 13	90 RCL 15
40 RCL 03	91 RCL 14
41 RCL 10	92 RCL 13
42 *	93 *
43 RCL 04	94 -
44 RCL 09	95 1
45 *	96 RCL 13
46 -	97 -
47 RCL 03	98 /

48 RCL 09
49 -
50 X↑2
51 RCL 04

99 STO 08
100 "DONE"
101 AVIEW
102 END

"SOIL" Program Listing

```
01 ♦ LBL "SOIL"
02 "R SOIL=?"
03 PROMPT
04 RCL 20
05 +
06 STO 09
07 'I SOIL=?"
08 PROMPT
09 RCL 21
10 +
11 STO 10
12 RCL 03
13 X↑2
14 RCL 04
15 X↑2
16 +
17 RCL 09
18 X↑2
19 RCL 10
20 X↑2
21 +
22 -
23 RCL 03
24 RCL 09
25 -
26 X↑2
27 RCL 04
28 RCL 10
29 -
30 X↑2
31 +
32 /
33 5
34 *
35 RCL 07
36 /
37 STO 16
38 RCL 03
39 RCL 10
40 *
41 RCL 04
42 RCL 09
43 *
44 -
45 100
46 /
47 RCL 03
48 RCL 09
49 -
50 X↑2
51 RCL 04
52 RCL 10
53 -
54 X↑2
55 +
56 /
57 RCL 08
58 -
59 RCL 07
60 /
61 300
62 *
63 STO 17
64 "CON="
65 ARCL 16
66 "MMHOS/M"
67 AVIEW
68 STOP
69 "DIEL="
70 ARCL 17
71 AVIEW
72 END
```

Keystrokes for Execution of "CAL" and "SOIL"			
"CAL" Keystrokes:		"SOIL" Keystrokes:	
User Enters:	Calculator Displays:	User Enters:	Calculator Displays:
[ON]	Y = ? X = ?	[ON]	Y = ? X = ?
[Shift] [GTO]	SOIL CAL	[SHIFT] [GTO]	SOIL CAL
[1/X] (CAL)	Y = ? X = ?	[Σ+] (SOIL)	Y = ? X = ?
[R/S]	R OFFSET = ?	[R/S]	R SOIL = ?
R Offset #		R Soil #	
[R/S]	I OFFSET = ?	[R/S]	I SOIL = ?
I Offset #		I Soil #	
[R/S]	R SHORT = ?	[R/S]	CON = __MMHOS/M
R Short #		[R/S]	DIEL = __
[R/S]	I SHORT = ?		
I Short #			
[R/S]	R AIR = ?		
R Air #			
[R/S]	I AIR = ?		
I Air #			
[R/S]	R METH = ?		
R Meth #			
[R/S]	I METH = ?		
I Meth #			
[R/S]	DONE		

Appendix B

Electrical Properties of Soils at 60 MHz

The following plots of electrical properties of soils versus volumetric moisture content at 60 MHz represent an interpolation of data collected at the U.S. Army Engineer Waterways Experiment Station in 1993. The laboratory technique was to calculate a complex dielectric constant from reflection/transmission measurements made in a temperature-controlled environment using an HP8510C Vector Network Analyzer (Curtis, Weiss, and Everett, In Preparation).¹ Soils A-L represent a broad spectrum of physical and chemical properties. The reference document should be referred to for details of testing and for additional explanations of how property calculations were made. Note that data were collected for samples at temperatures of 10, 20, 30, and 40 °C.

¹ References cited in this appendix are located at the end of the main text.

60 MHz

TMP=10

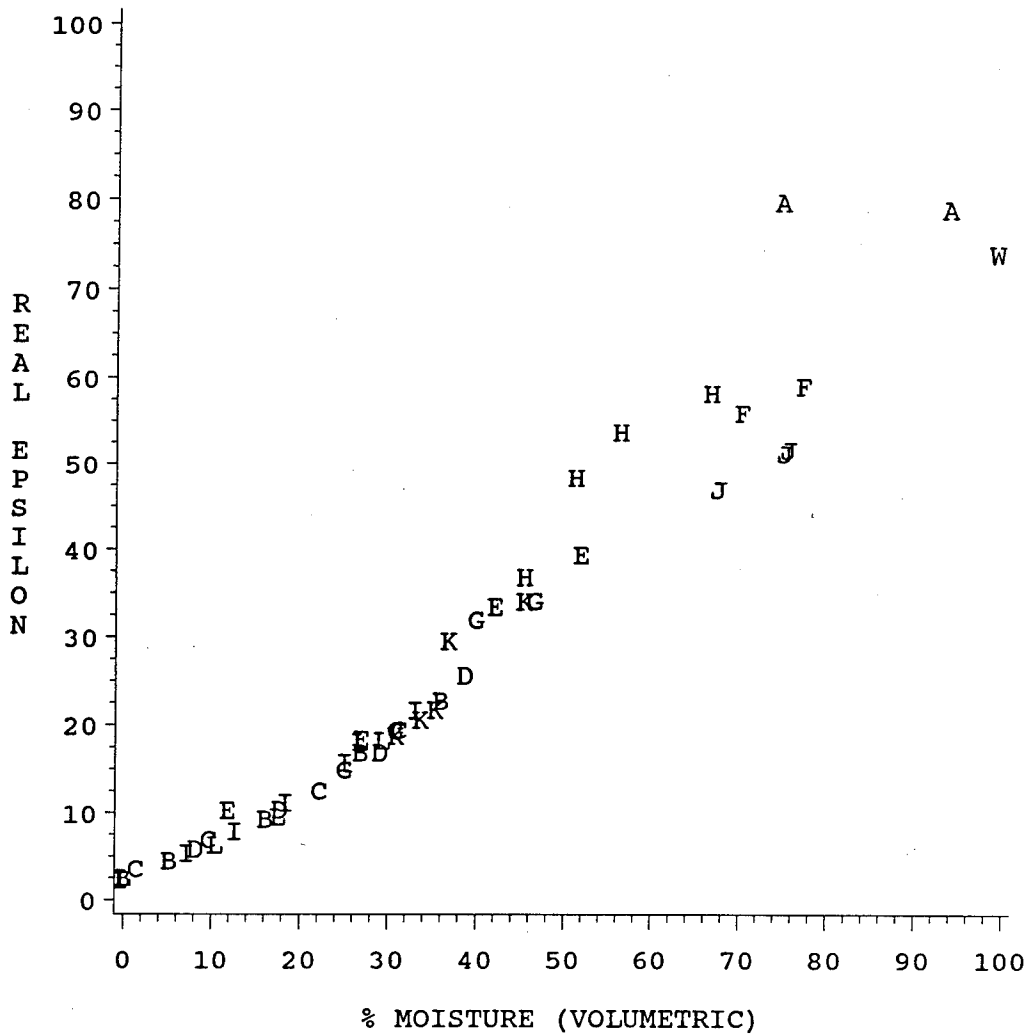

SOIL	A	A	A	A	B	B	B	B	C	C	C	C	D	D	D	D
	E	E	E	E	F	F	F	F	G	G	G	G	H	H	H	H
	I	I	I	I	J	J	J	J	K	K	K	K	L	L	L	L
	W	W	W	WATER												

60 MHz

TMP=10

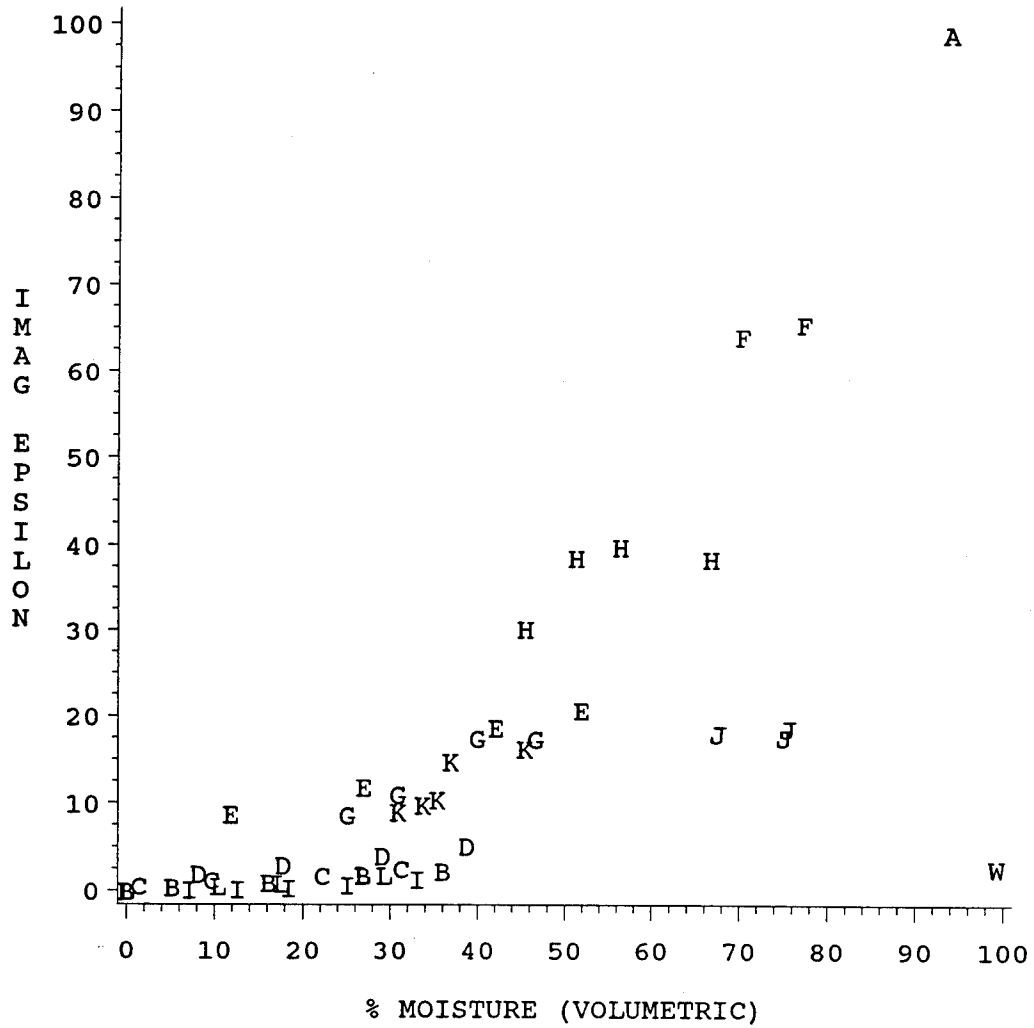

SOIL	A	A	A	A	B	B	B	B	C	C	C	C	D	D	D	D
	E	E	E	E	F	F	F	F	G	G	G	G	H	H	H	H
	I	I	I	I	J	J	J	J	K	K	K	K	L	L	L	L
	W	W	W	WATER												

60 MHz

TMP=10

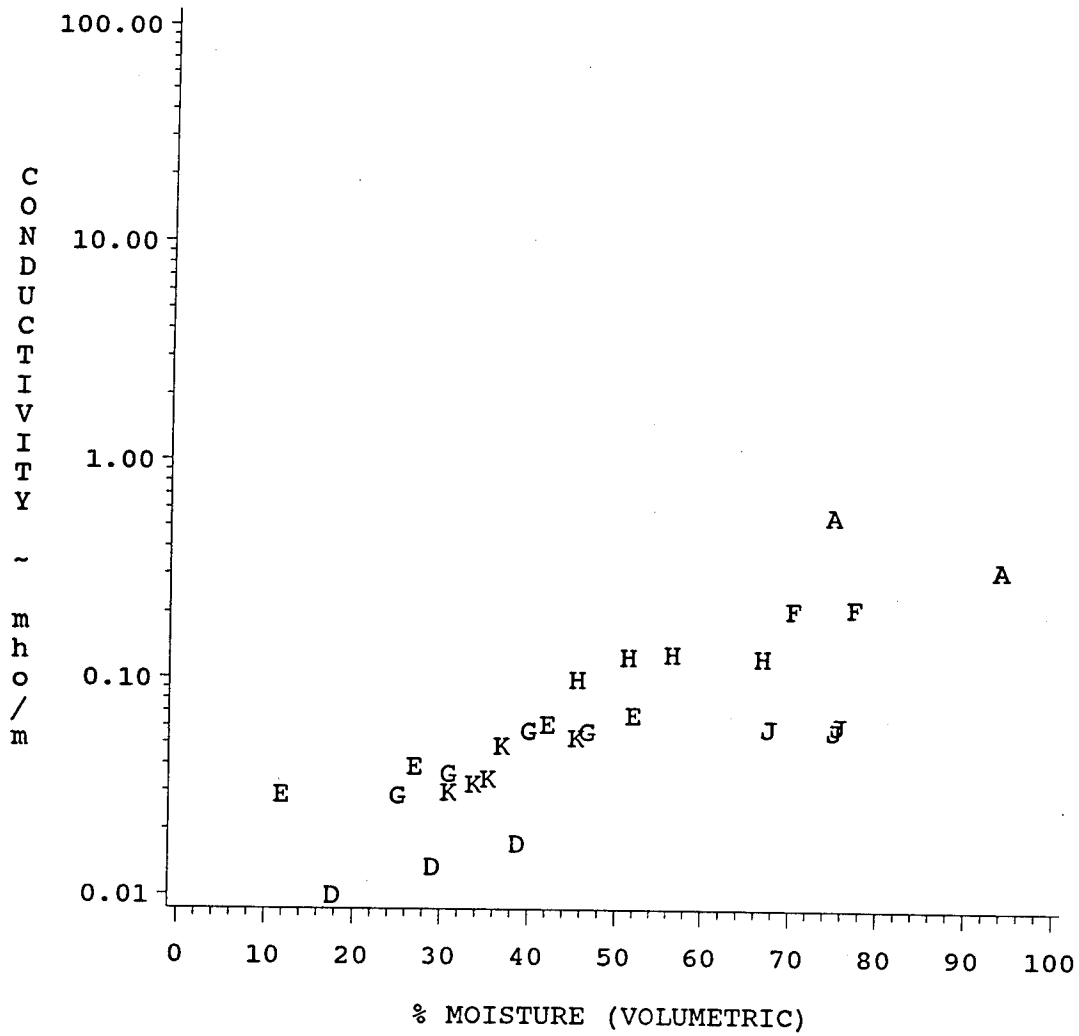

SOIL	A	A	A	A	B	B	B	B	C	C	C	C	D	D	D	D
	E	E	E	E	F	F	F	F	G	G	G	G	H	H	H	H
	I	I	I	I	J	J	J	J	K	K	K	K	L	L	L	L
	W	W	W	WATER												

60 MHz

TMP=10

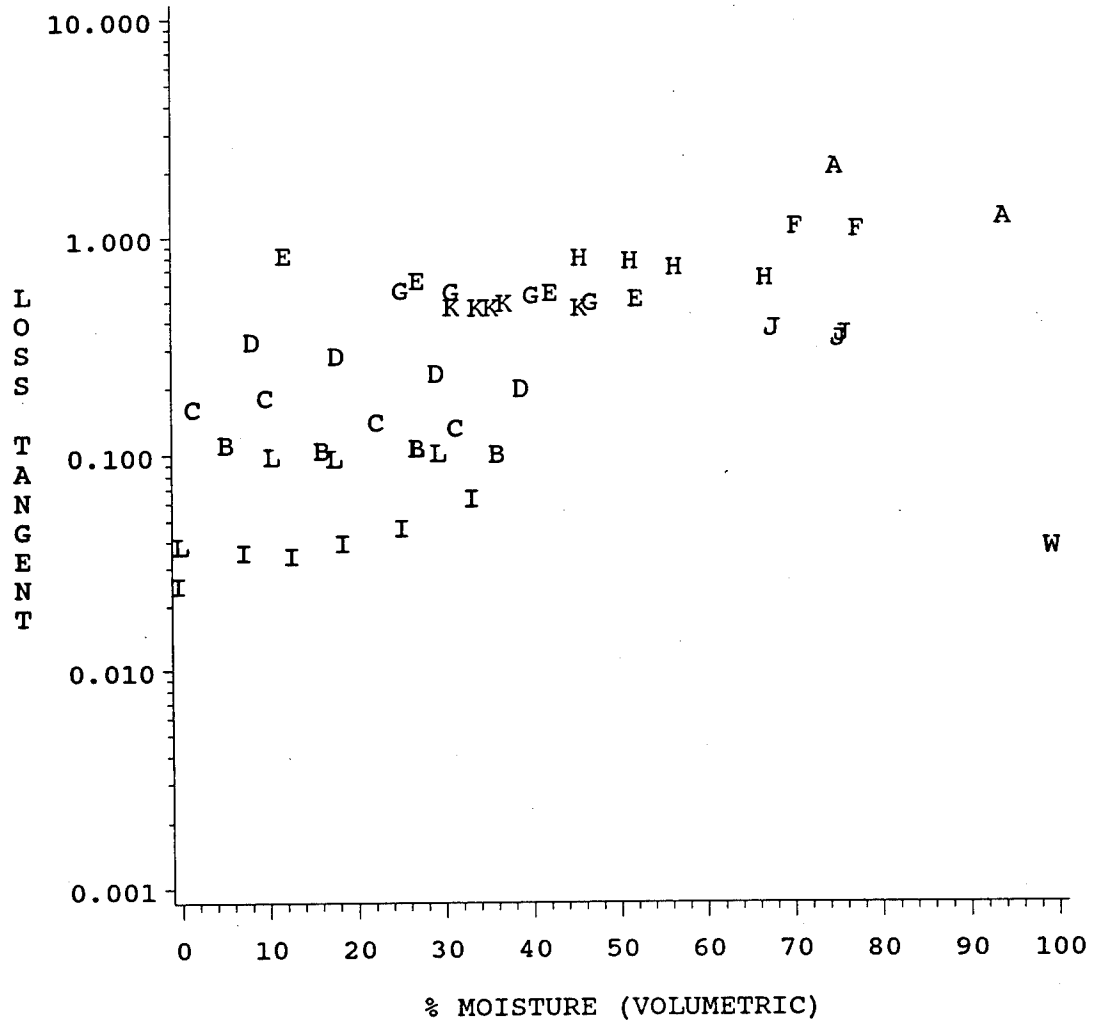

SOIL	A	A	A	A	B	B	B	B	C	C	C	C	D	D	D	D
	E	E	E	E	F	F	F	F	G	G	G	G	H	H	H	H
	I	I	I	I	J	J	J	J	K	K	K	K	L	L	L	L
	W	W	W	WATER												

60 MHz

TMP=10

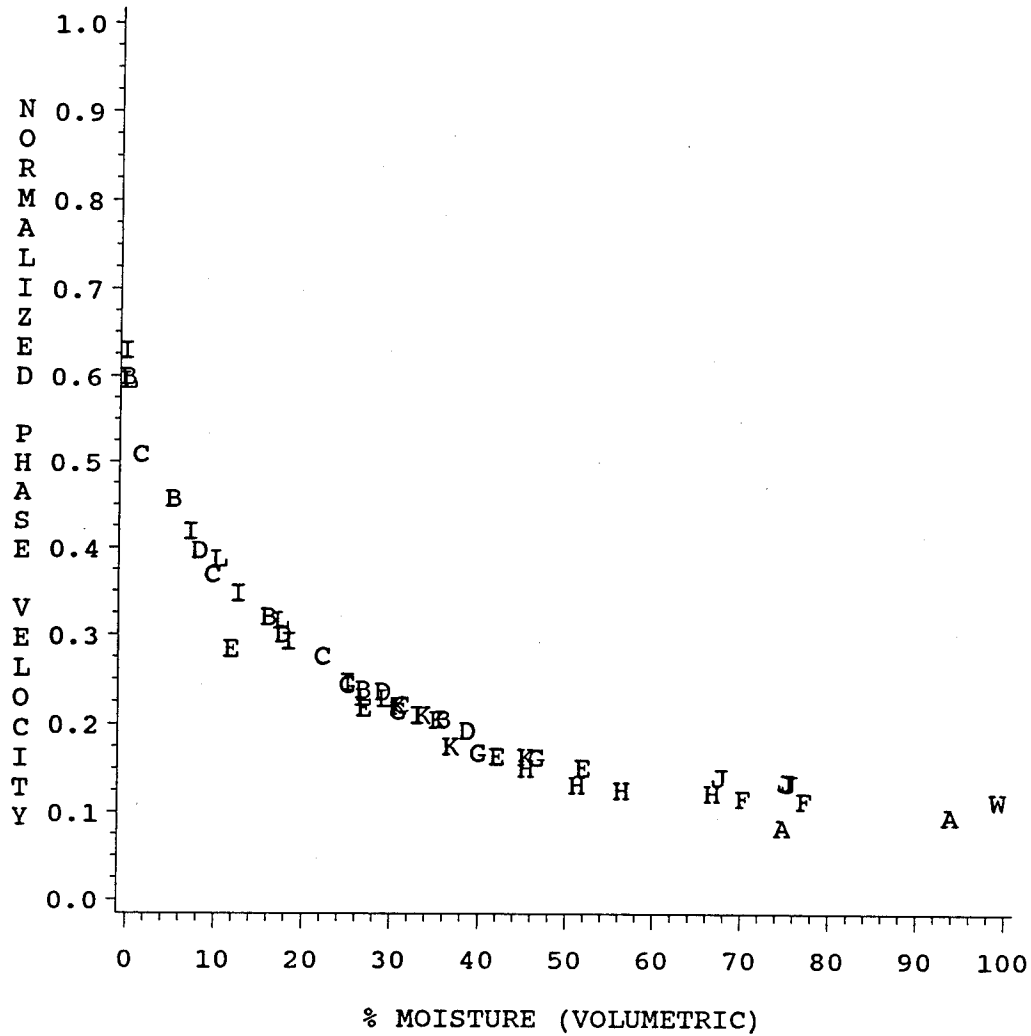

SOIL	A	A	A	A	B	B	B	B	C	C	C	C	D	D	D	D
	E	E	E	E	F	F	F	F	G	G	G	G	H	H	H	H
	I	I	I	I	J	J	J	J	K	K	K	K	L	L	L	L
	W	W	W	WATER												

60 MHz

TMP=10

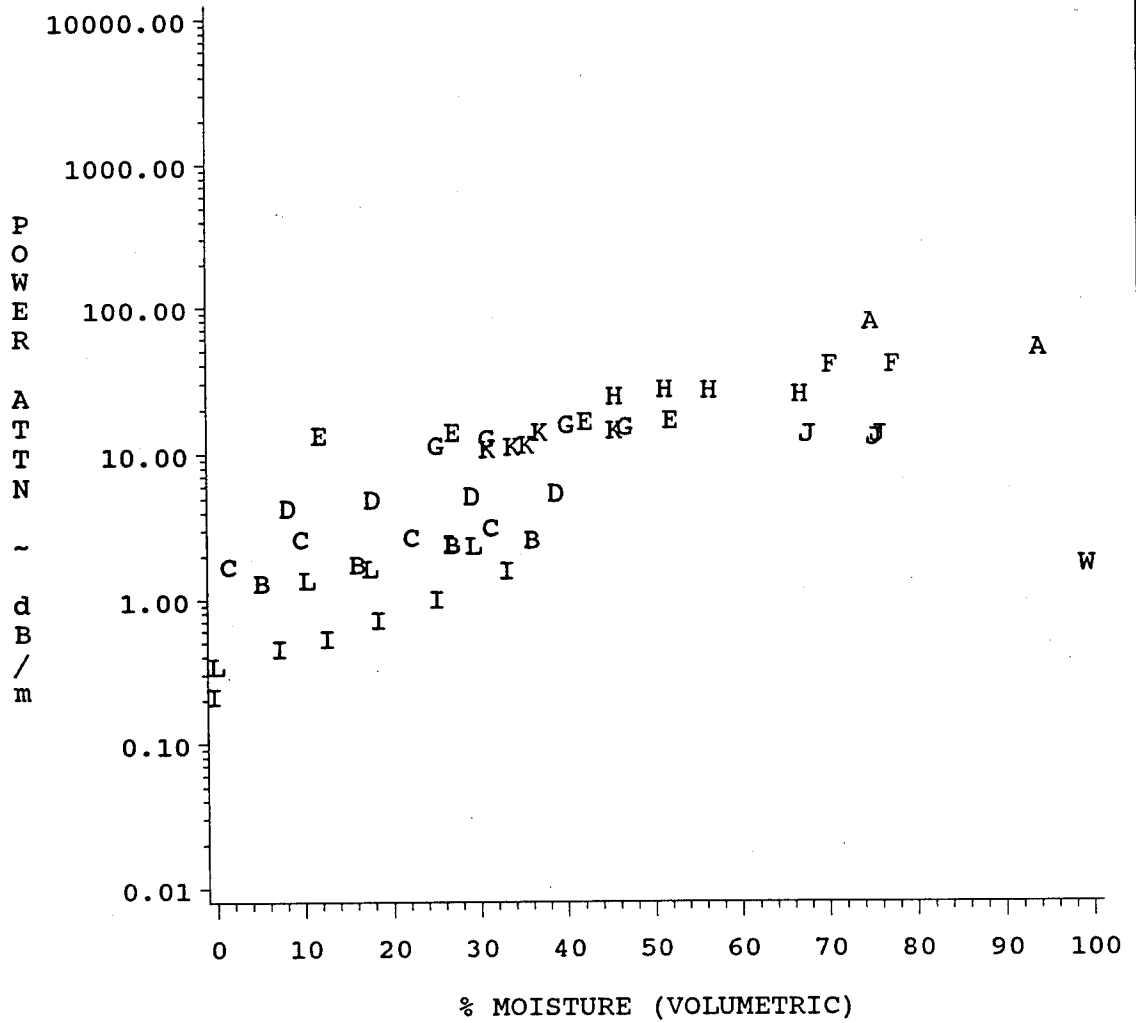

SOIL	A	A	A	A	B	B	B	B	C	C	C	C	D	D	D	D
	E	E	E	E	F	F	F	F	G	G	G	G	H	H	H	H
	I	I	I	I	J	J	J	J	K	K	K	K	L	L	L	L
	W	W	W	WATER												

60 MHz

TMP=20

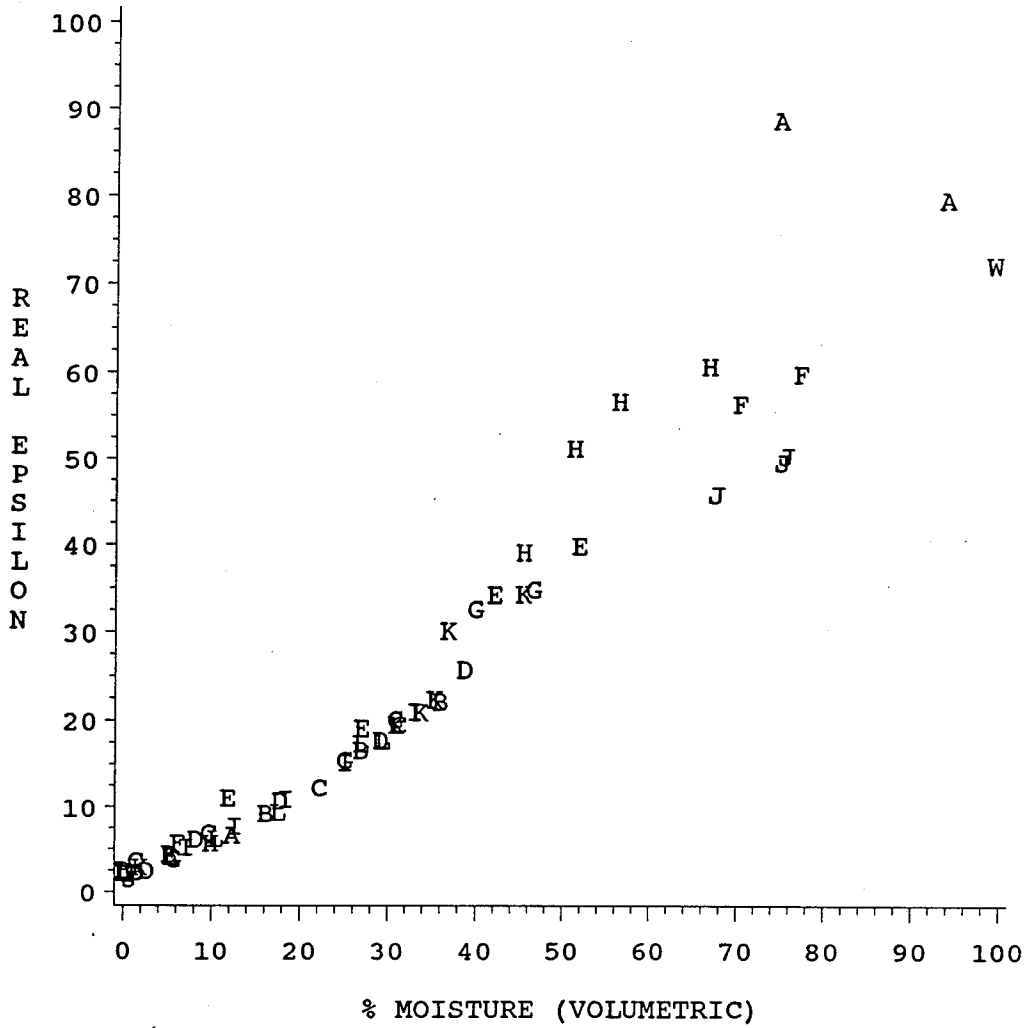

SOIL	A	A	A	A	B	B	B	B	C	C	C	C	D	D	D	D
	E	E	E	E	F	F	F	F	G	G	G	G	H	H	H	H
	I	I	I	I	J	J	J	J	K	K	K	K	L	L	L	L
	W	W	W	WATER												

60 MHz

TMP=20

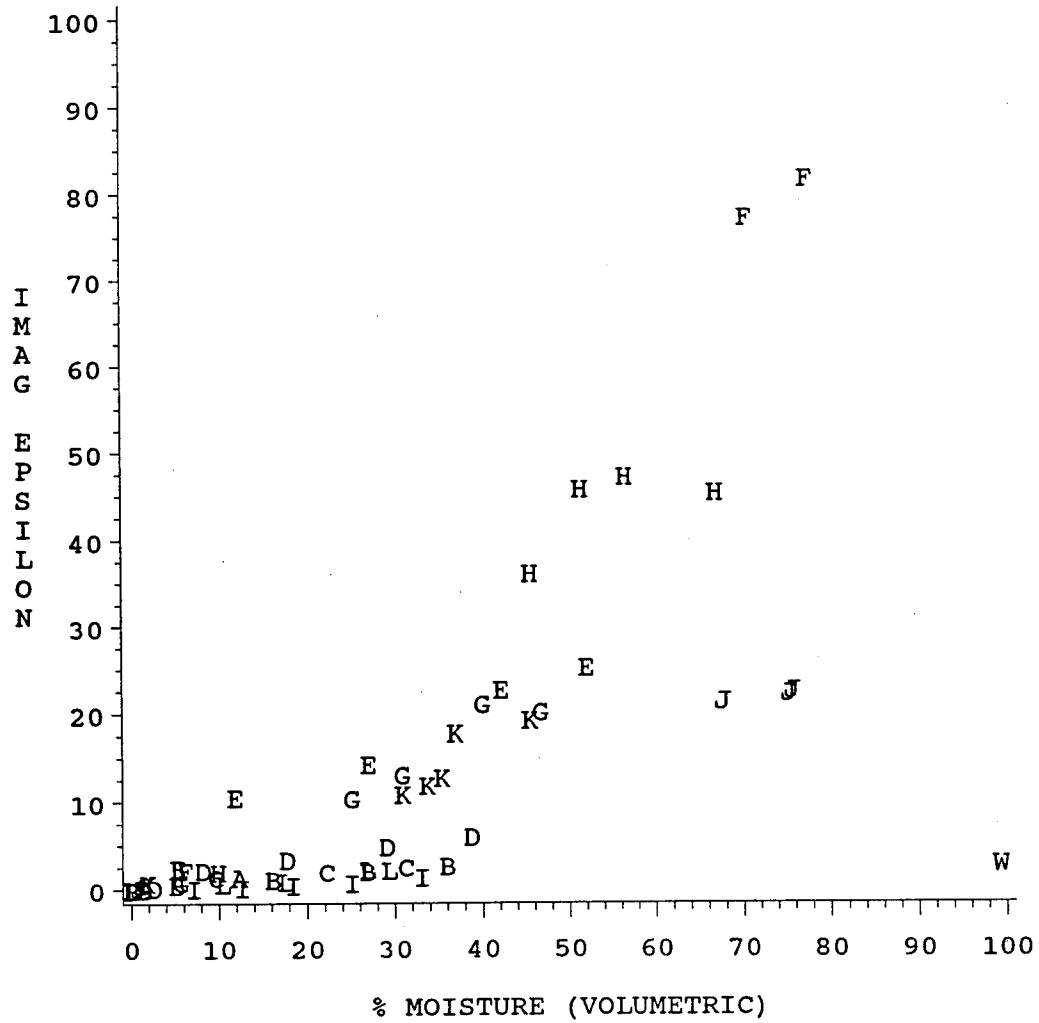

SOIL	A	A	A	A	B	B	B	B	C	C	C	C	D	D	D	D
	E	E	E	E	F	F	F	F	G	G	G	G	H	H	H	H
	I	I	I	I	J	J	J	J	K	K	K	K	L	L	L	L
	W	W	W	WATER												

60 MHz

TMP=20

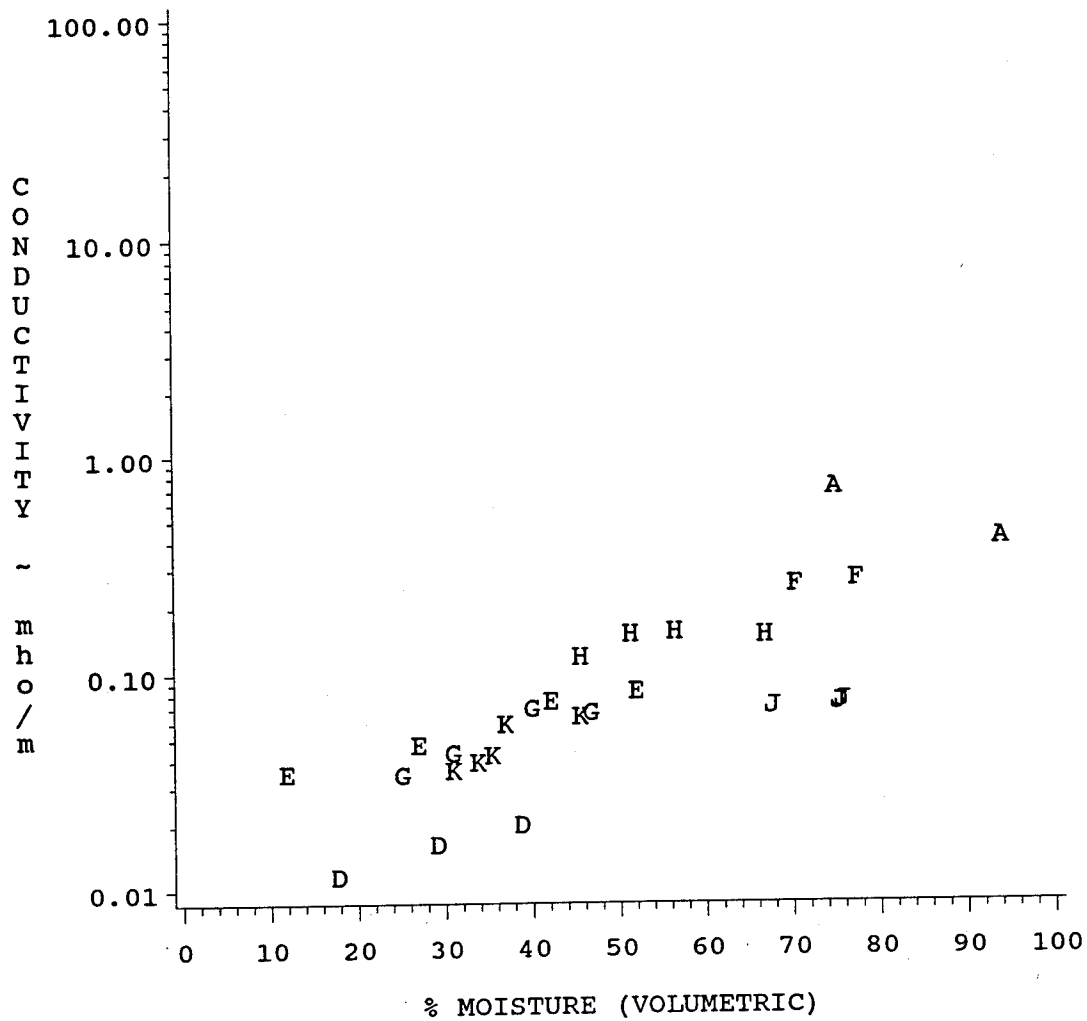

SOIL	A	A	A	A	B	B	B	B	C	C	C	C	D	D	D	D
	E	E	E	E	F	F	F	F	G	G	G	G	H	H	H	H
	I	I	I	I	J	J	J	J	K	K	K	K	L	L	L	L
	W	W	W	WATER												

60 MHz

TMP=20

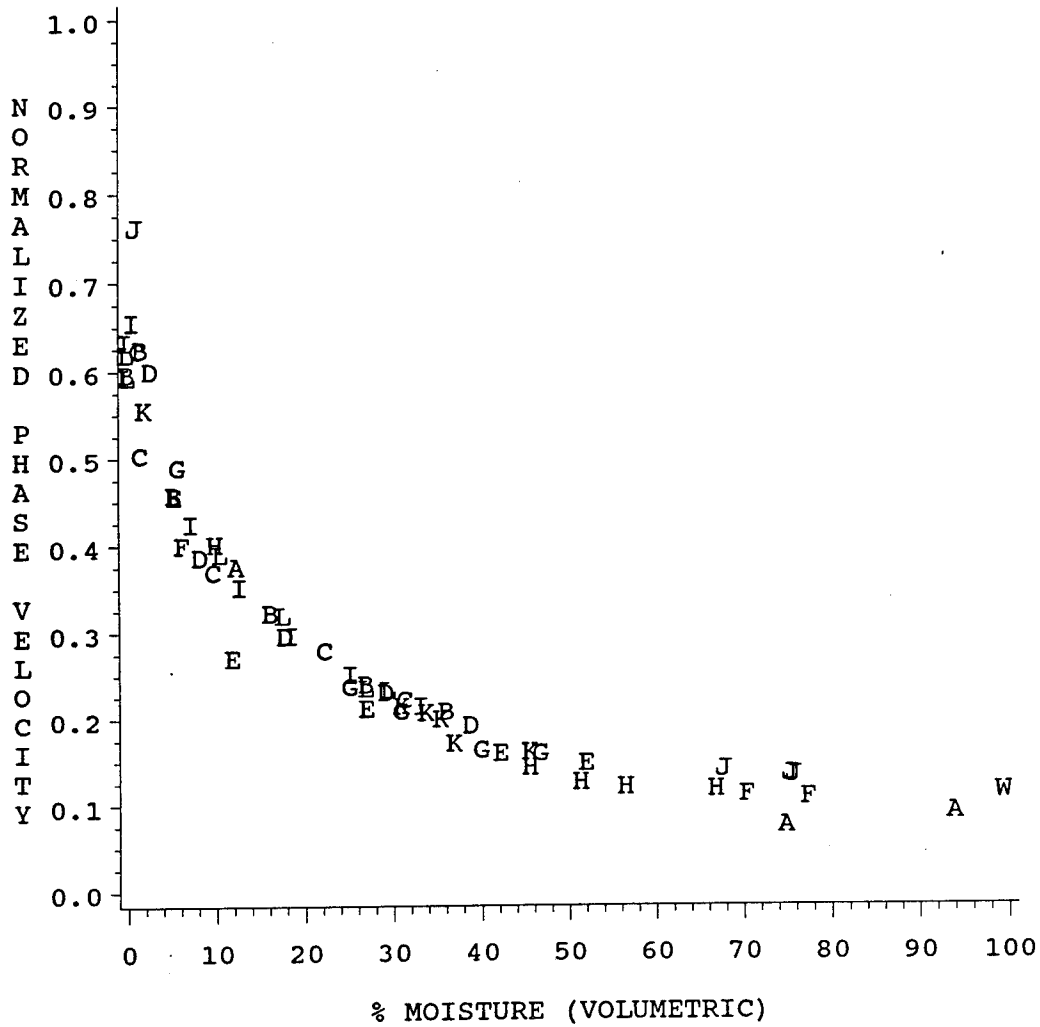

SOIL	A	A	A	A	B	B	B	B	C	C	C	C	D	D	D	D
	E	E	E	E	F	F	F	F	G	G	G	G	H	H	H	H
	I	I	I	I	J	J	J	J	K	K	K	K	L	L	L	L
	W	W	W	WATER												

60 MHz

TMP=20

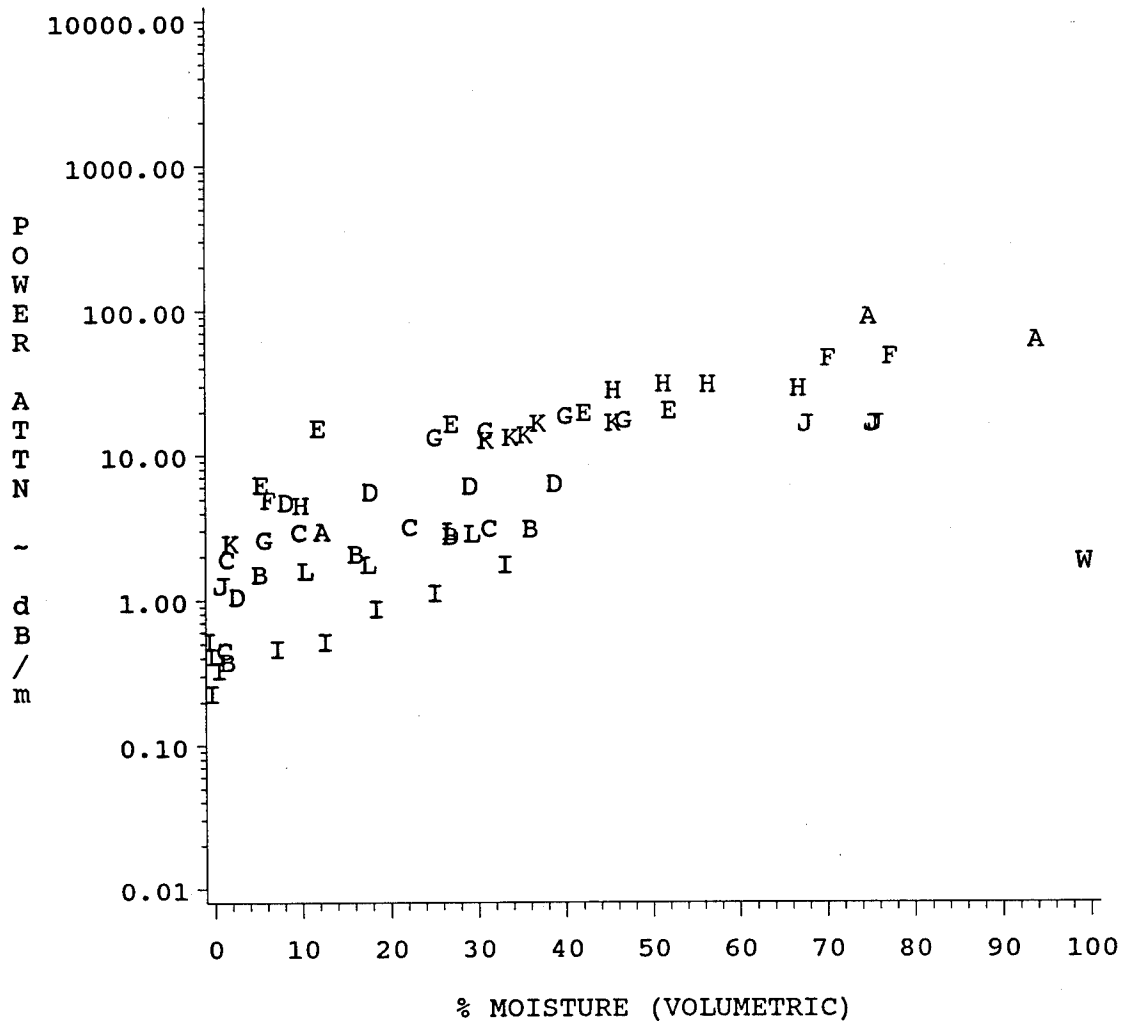

SOIL	A	A	A	A	B	B	B	B	C	C	C	C	D	D	D	D
	E	E	E	E	F	F	F	F	G	G	G	G	H	H	H	H
	I	I	I	I	J	J	J	J	K	K	K	K	L	L	L	L
	W	W	W	WATER												

60 MHz

TMP=30

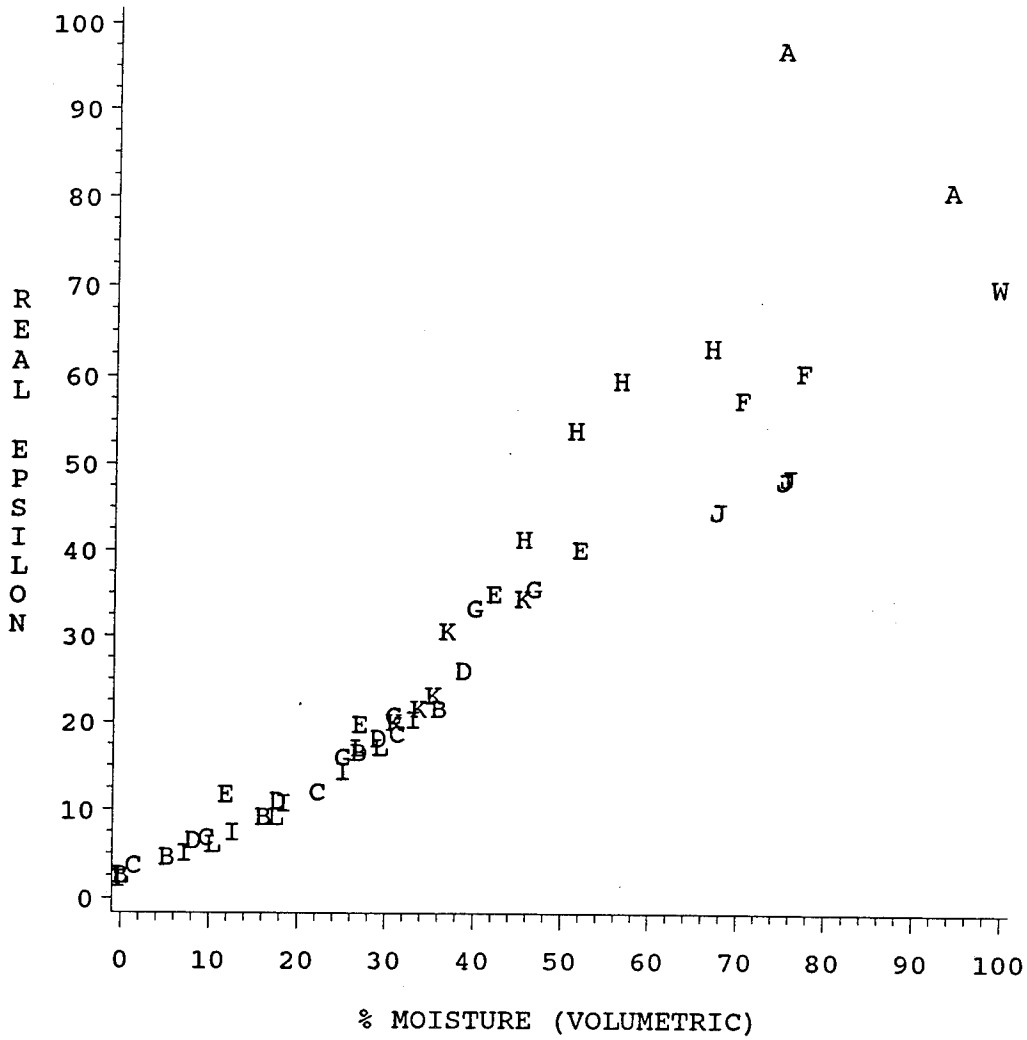

SOIL	A	A	A	A	B	B	B	B	C	C	C	C	D	D	D	D
	E	E	E	E	F	F	F	F	G	G	G	G	H	H	H	H
	I	I	I	I	J	J	J	J	K	K	K	K	L	L	L	L
	W	W	W	WATER												

60 MHz

TMP=30

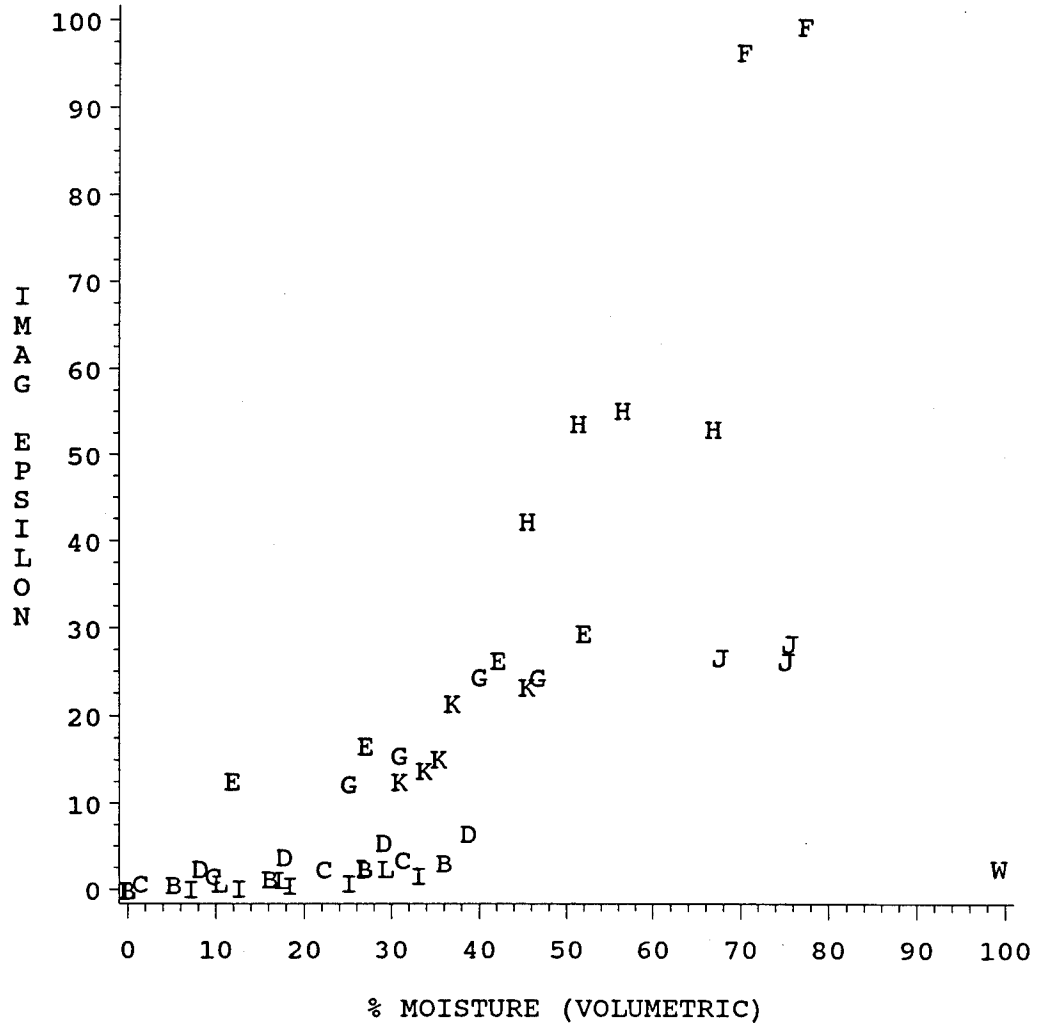

SOIL	A	A	A	A	B	B	B	B	C	C	C	C	D	D	D	D
	E	E	E	E	F	F	F	F	G	G	G	G	H	H	H	H
	I	I	I	I	J	J	J	J	K	K	K	K	L	L	L	L
	W	W	W	WATER												

60 MHz

TMP=30

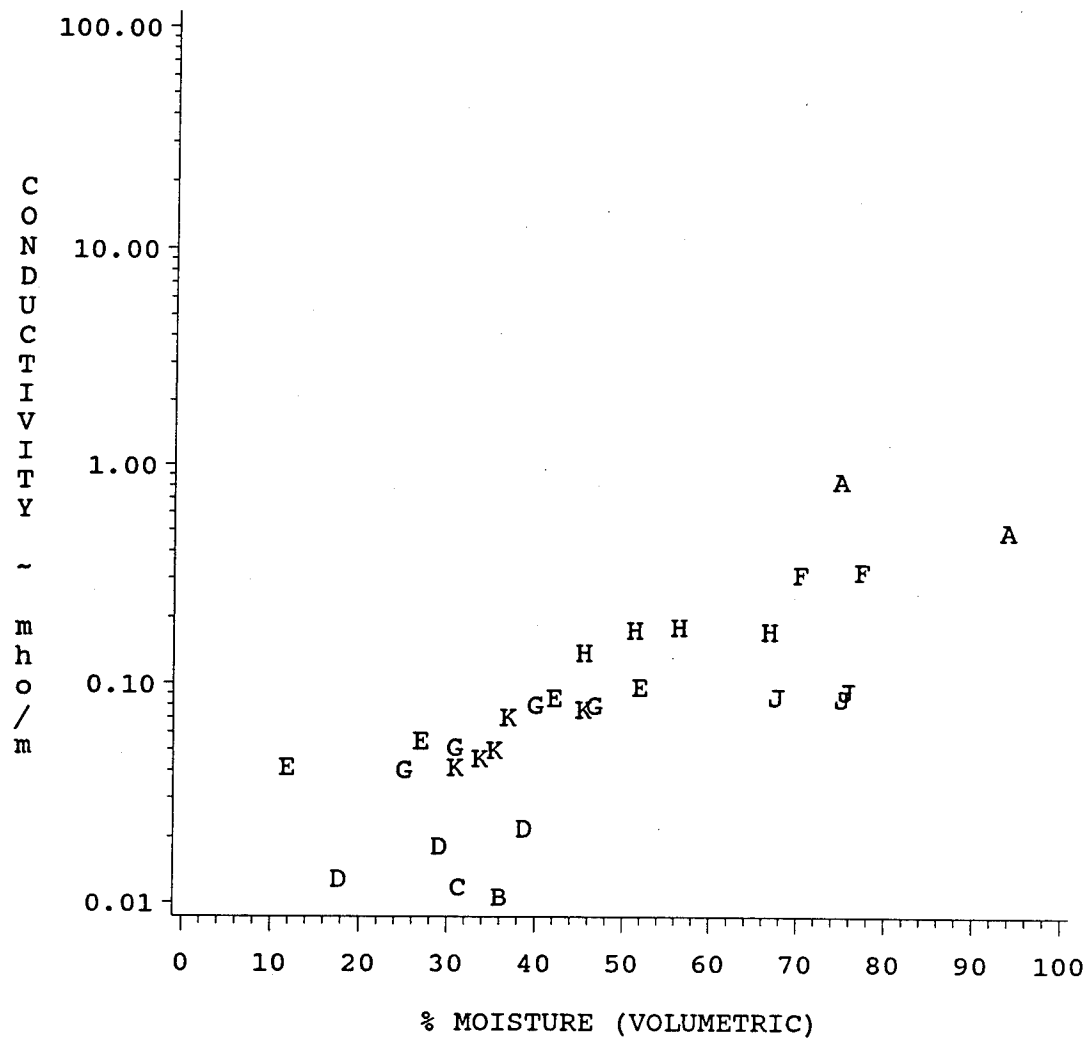

SOIL	A	A	A	A	B	B	B	B	C	C	C	C	D	D	D	D
	E	E	E	E	F	F	F	F	G	G	G	G	H	H	H	H
	I	I	I	I	J	J	J	J	K	K	K	K	L	L	L	L
	W	W	W	WATER												

60 MHz

TMP=30

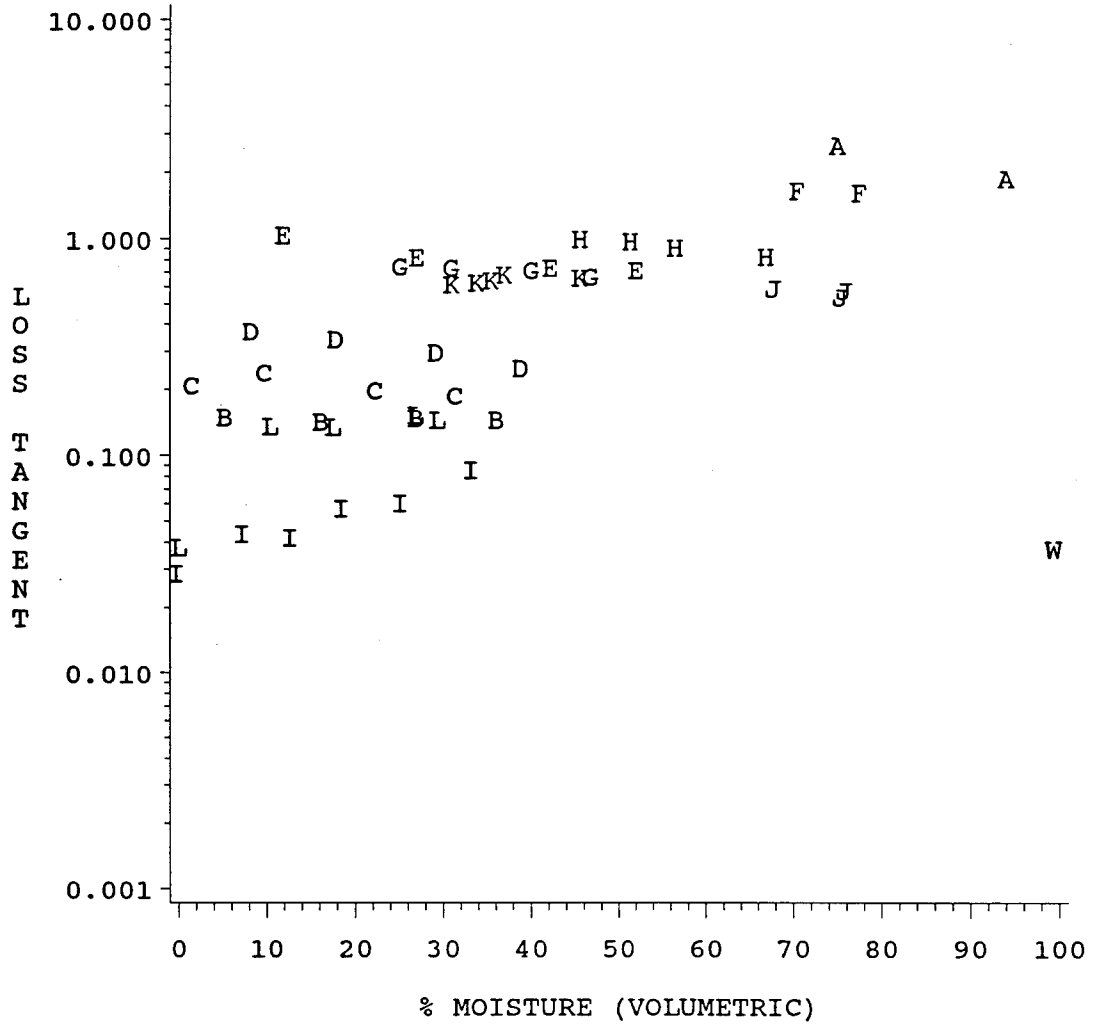

SOIL	A	A	A	A	B	B	B	B	C	C	C	C	D	D	D	D
	E	E	E	E	F	F	F	F	G	G	G	G	H	H	H	H
	I	I	I	I	J	J	J	J	K	K	K	K	L	L	L	L
	W	W	W	WATER												

60 MHz

TMP=30

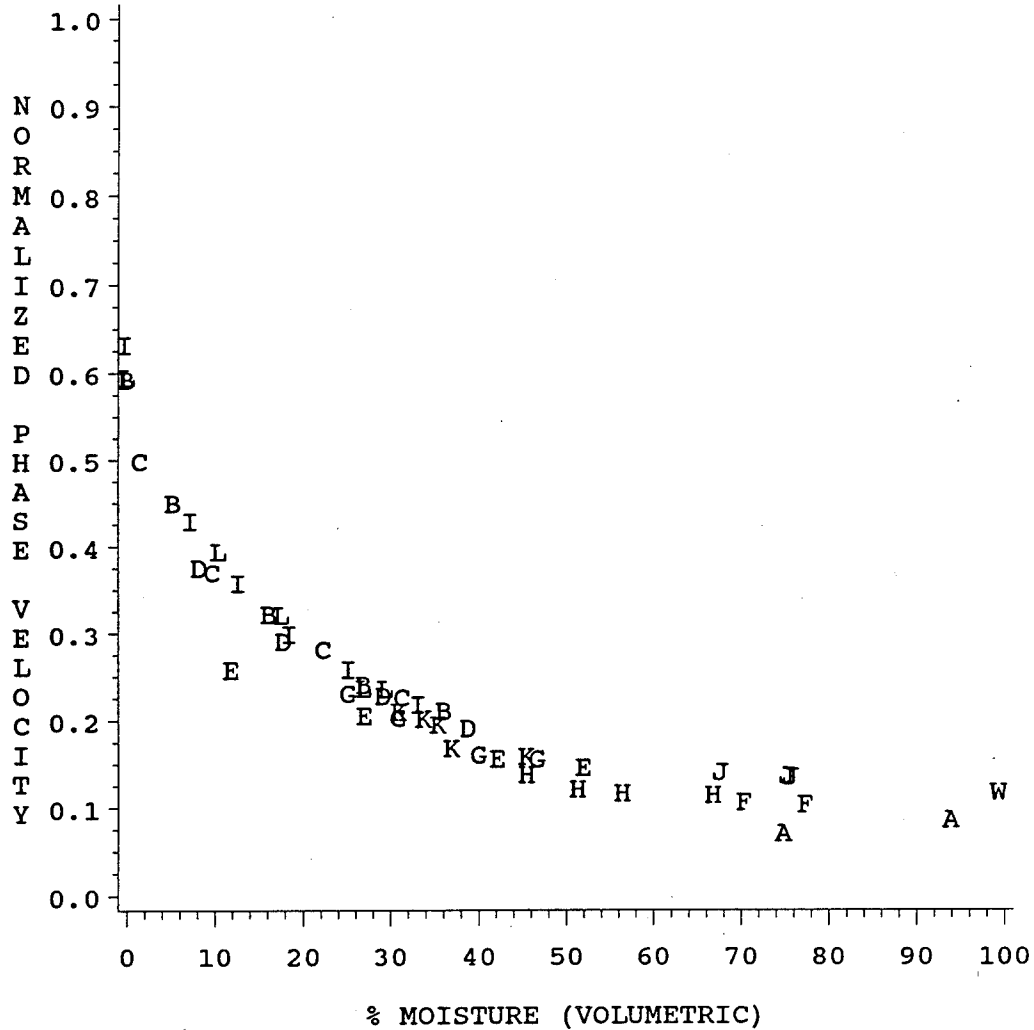

SOIL	A	A	A	A	B	B	B	B	C	C	C	C	D	D	D	D
	E	E	E	E	F	F	F	F	G	G	G	G	H	H	H	H
	I	I	I	I	J	J	J	J	K	K	K	K	L	L	L	L
	W	W	W	WATER												

60 MHz

TMP=30

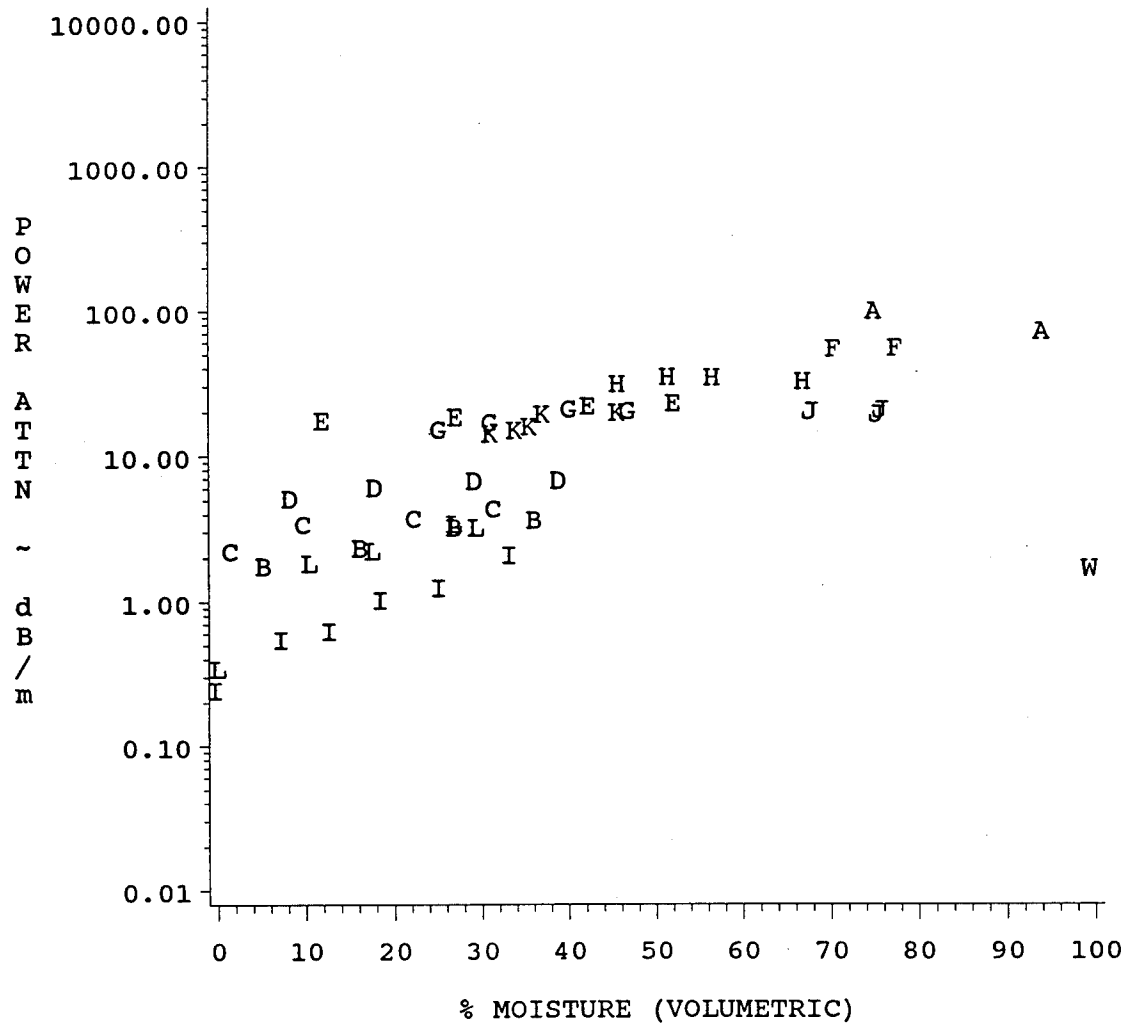

SOIL	A	A	A	A	B	B	B	B	C	C	C	C	D	D	D	D
	E	E	E	E	F	F	F	F	G	G	G	G	H	H	H	H
	I	I	I	I	J	J	J	J	K	K	K	K	L	L	L	L
	W	W	W	WATER												

60 MHz

TMP=40

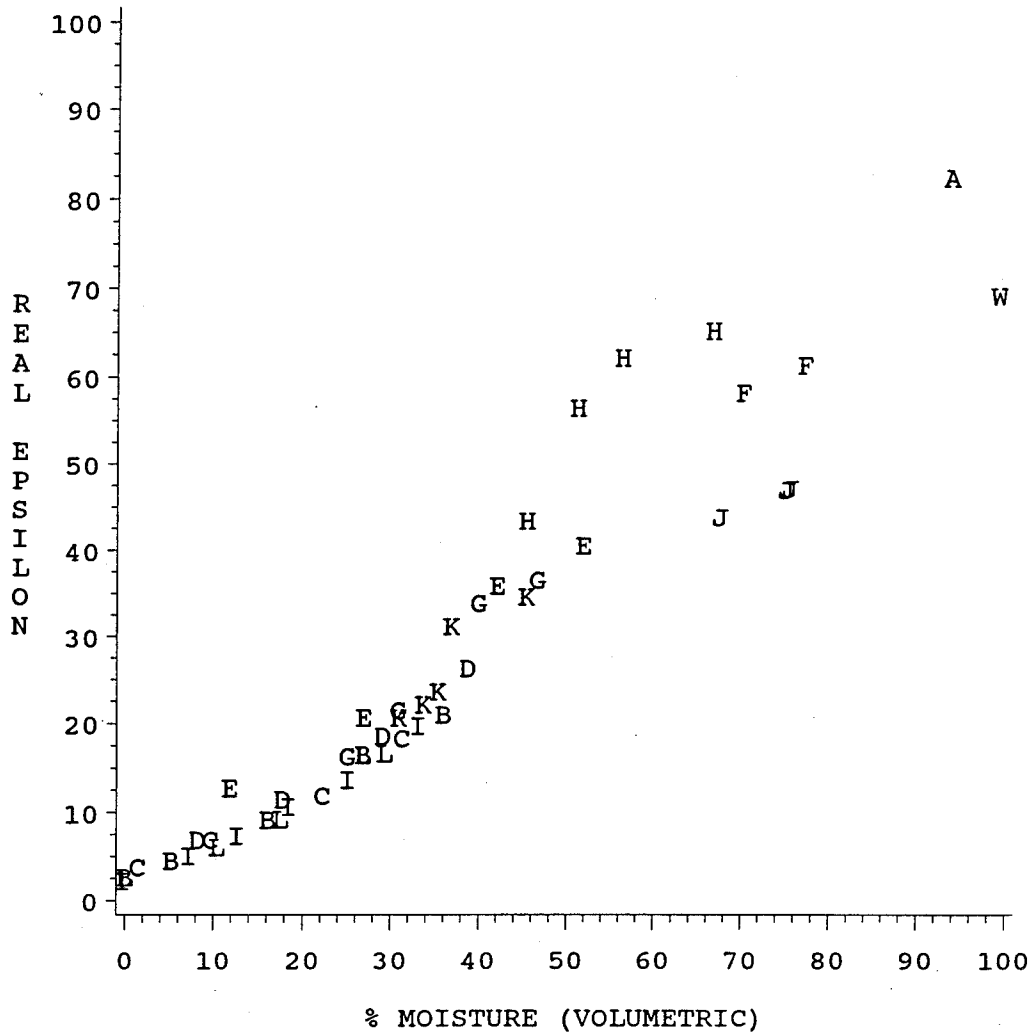

SOIL	A	A	A	A	B	B	B	B	C	C	C	C	D	D	D	D
	E	E	E	E	F	F	F	F	G	G	G	G	H	H	H	H
	I	I	I	I	J	J	J	J	K	K	K	K	L	L	L	L
	W	W	W	WATER												

60 MHz

TMP=40

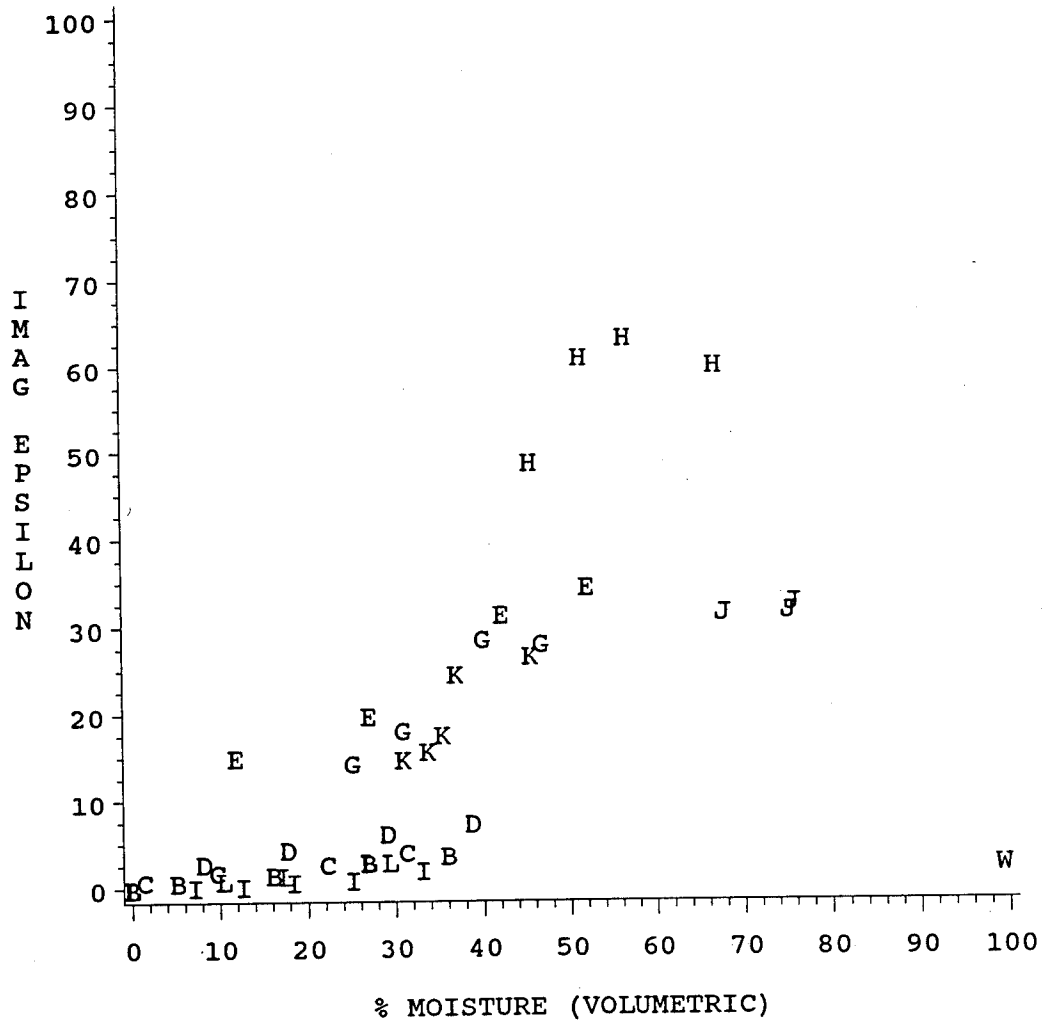

60 MHz

TMP=40

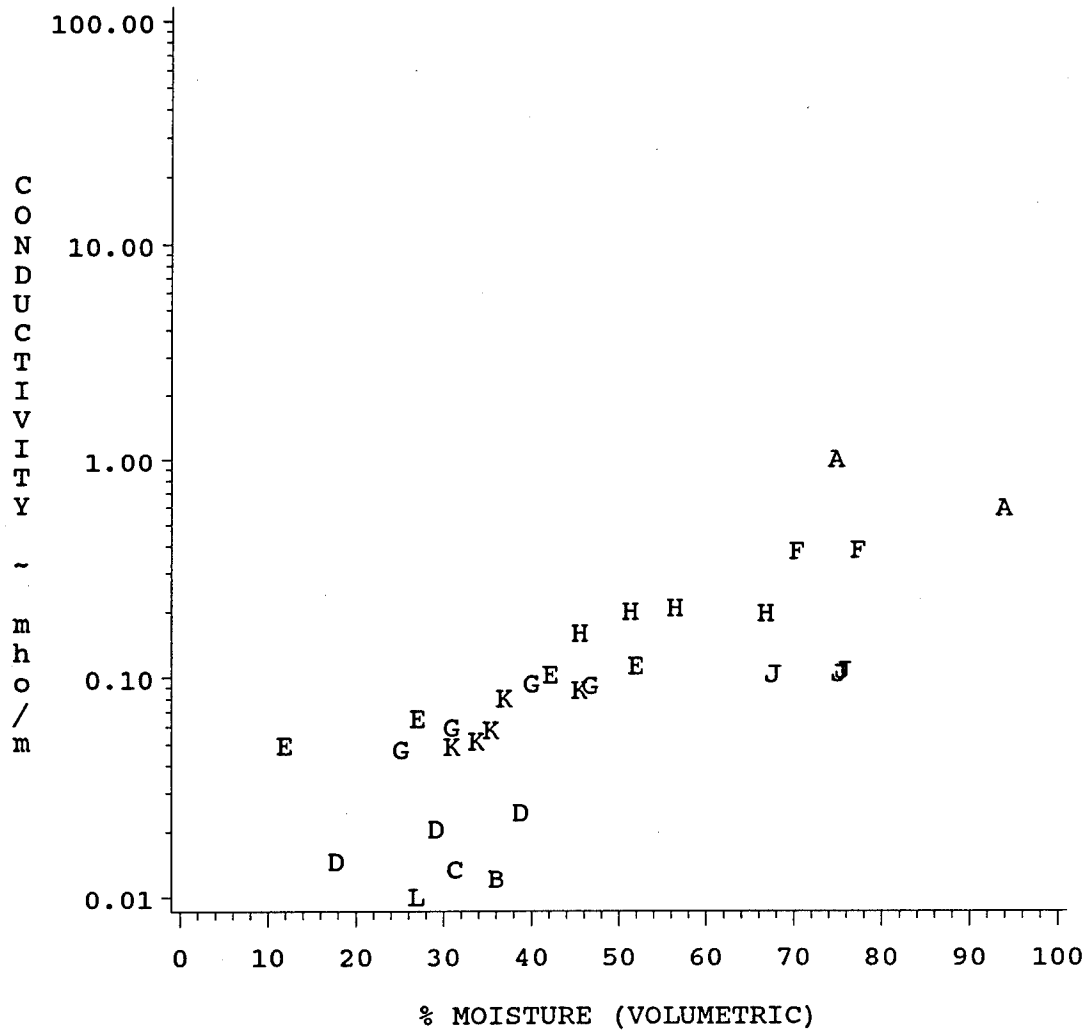

SOIL	A	A	A	A	B	B	B	B	C	C	C	C	D	D	D	D
	E	E	E	E	F	F	F	F	G	G	G	G	H	H	H	H
	I	I	I	I	J	J	J	J	K	K	K	K	L	L	L	L
	W	W	W	WATER												

60 MHz

TMP=40

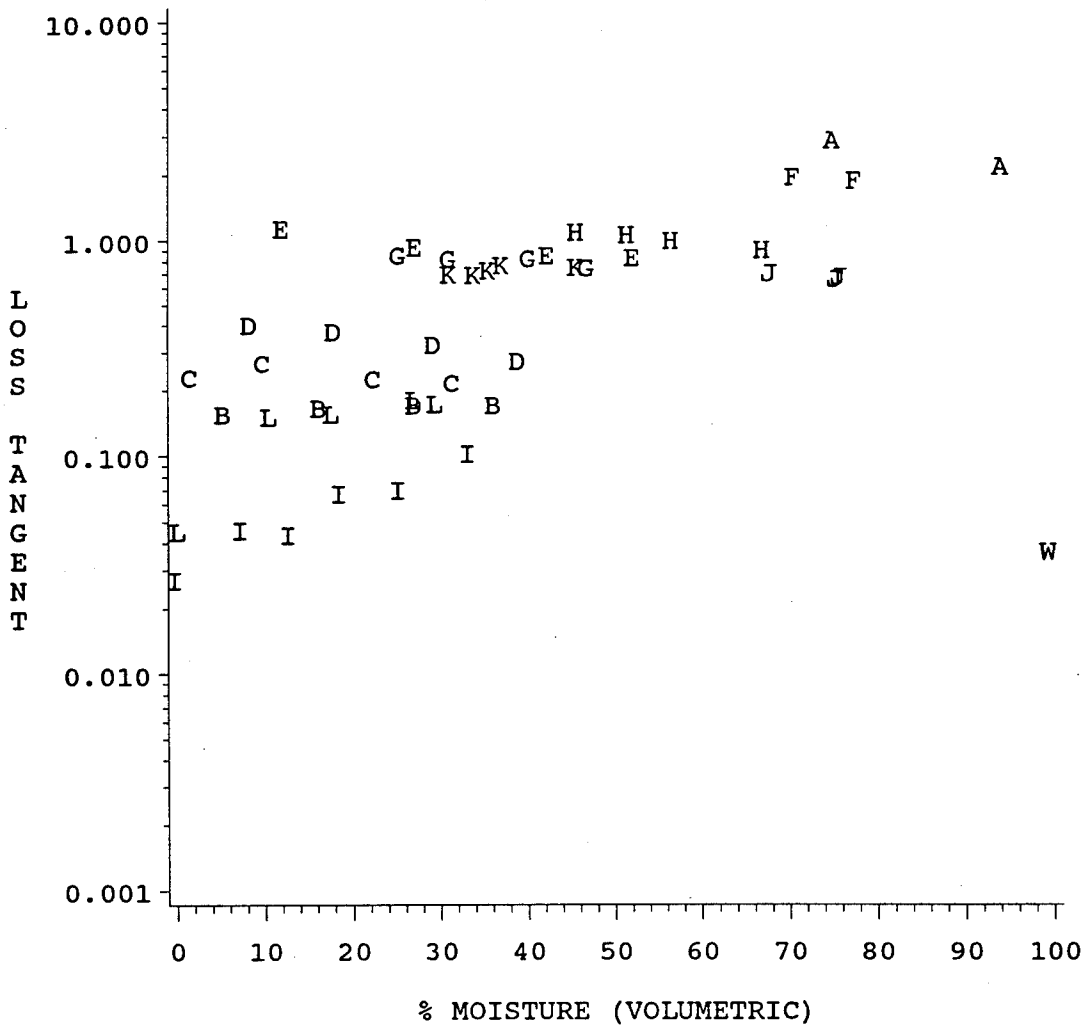

SOIL	A	A	A	A	B	B	B	B	C	C	C	C	D	D	D	D
	E	E	E	E	F	F	F	F	G	G	G	G	H	H	H	H
	I	I	I	I	J	J	J	J	K	K	K	K	L	L	L	L
	W	W	W	WATER												

60 MHz

TMP=40

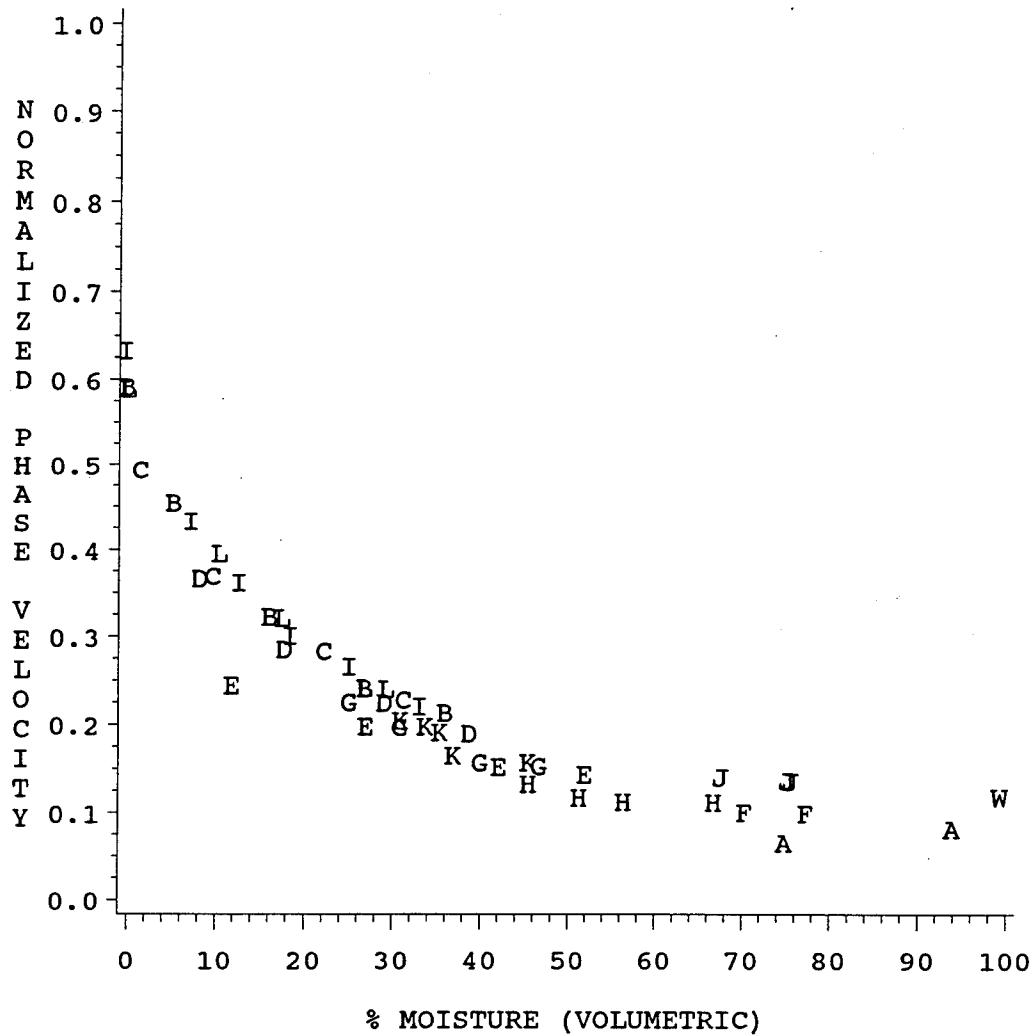

SOIL	A	A	A	A	B	B	B	B	C	C	C	C	D	D	D	D
	E	E	E	E	F	F	F	F	G	G	G	G	H	H	H	H
	I	I	I	I	J	J	J	J	K	K	K	K	L	L	L	L
	W	W	W	WATER												

60 MHz

TMP=40

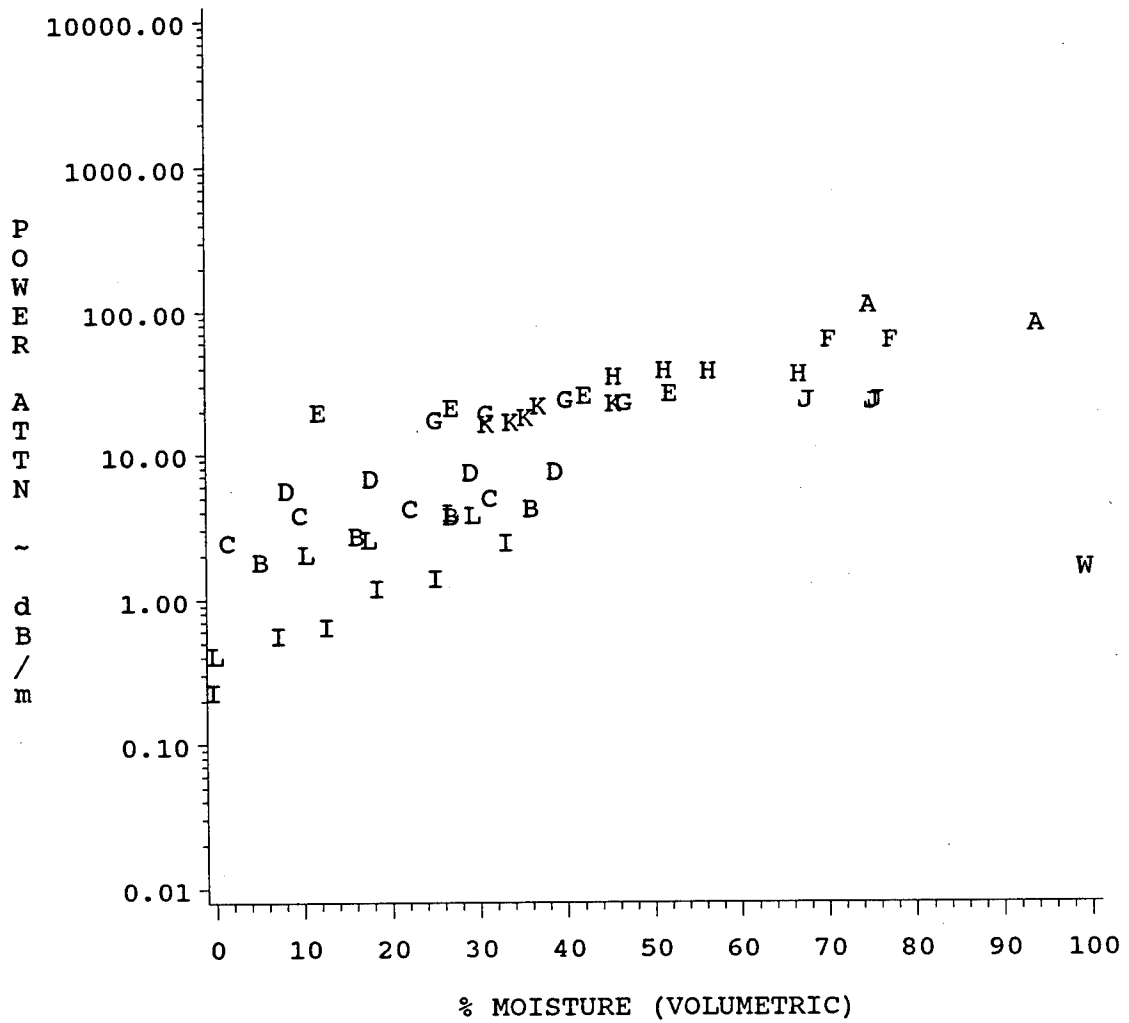

SOIL	A	A	A	A	B	B	B	B	C	C	C	C	D	D	D	D
	E	E	E	E	F	F	F	F	G	G	G	G	H	H	H	H
	I	I	I	I	J	J	J	J	K	K	K	K	L	L	L	L
	W	W	W	WATER												

REPORT DOCUMENTATION PAGE

Form Approved
OMB No. 0704-0188

Public reporting burden for this collection of information is estimated to average 1 hour per response, including the time for reviewing instructions, searching existing data sources, gathering and maintaining the data needed, and completing and reviewing the collection of information. Send comments regarding this burden estimate or any other aspect of this collection of information, including suggestions for reducing this burden, to Washington Headquarters Services, Directorate for Information Operations and Reports, 1215 Jefferson Davis Highway, Suite 1204, Arlington, VA 22202-4302, and to the Office of Management and Budget, Paperwork Reduction Project (0704-0188), Washington, DC 20503.

1. AGENCY USE ONLY (Leave blank)		2. REPORT DATE February 1996	3. REPORT TYPE AND DATES COVERED Final report	
4. TITLE AND SUBTITLE A Prototype Microwave Probe and Reflectometer for In Situ Measurement of Soil Electrical Properties			5. FUNDING NUMBERS	
6. AUTHOR(S) Joel B. Everett, John O. Curtis				
7. PERFORMING ORGANIZATION NAME(S) AND ADDRESS(ES) U.S. Army Engineer Waterways Experiment Station 3909 Halls Ferry Road Vicksburg, MS 39180-6199			8. PERFORMING ORGANIZATION REPORT NUMBER Miscellaneous Paper EL-96-1	
9. SPONSORING / MONITORING AGENCY NAME(S) AND ADDRESS(ES) U.S. Army Corps of Engineers Research and Development Directorate Washington, DC 20314-1000			10. SPONSORING / MONITORING AGENCY REPORT NUMBER	
11. SUPPLEMENTARY NOTES Available from National Technical Information Service, 5285 Port Royal Road, Springfield, VA 22161.				
12a. DISTRIBUTION / AVAILABILITY STATEMENT Approved for public release; distribution is unlimited.			12b. DISTRIBUTION CODE	
13. ABSTRACT (Maximum 200 words) <p>A number of simple experiments were performed on a microwave reflectometer, operating at 60 MHz, to test the feasibility of its use as a tool for accurately measuring the complex electrical properties of soils. Such knowledge could be used to predict electromagnetic wave attenuation, the volumetric moisture contained within soil near the probe surface, and, through the relative changes in soil properties either over surface areas or as a function of depth below the surface, the presence of harmful contaminants.</p> <p>Background information contained within this report includes a review of similar microwave sensor applications and a description of the basic relationships used to convert sensor voltage measurements into relative dielectric permittivity and conductivity. Experiments were conducted to investigate the volume of soil that would be measured by the soil and to determine the sensitivity of the instrument. While permittivity measurements appeared to be quite good, conductivity measurements in low-conductivity materials were not as reliable. A simple analytical study indicated that the conductivity measurements would be quite sensitive to the accuracy of the voltmeter being used by the reflectometer. In most soils, the frequency of operation and the sensitivity of this system will allow the field lines to extend about 1 cm away from the probe surface, making the probe ideal for surface measurements and well suited to being placed in a borehole or cone penetrometer environment to obtain vertical profiles of soil properties. Numerous improvements to the measurement system were recommended to improve its sensitivity and utility.</p>				
14. SUBJECT TERMS Dielectric properties Reflectometer Soil moisture			15. NUMBER OF PAGES 82	
			16. PRICE CODE	
17. SECURITY CLASSIFICATION OF REPORT UNCLASSIFIED	18. SECURITY CLASSIFICATION OF THIS PAGE UNCLASSIFIED	19. SECURITY CLASSIFICATION OF ABSTRACT	20. LIMITATION OF ABSTRACT	