

**NAVAL POSTGRADUATE SCHOOL
Monterey, California**



THESIS

**THEATER LEVEL OPERATIONS: MODELING GROUND UNIT
LOGISTICAL REQUIREMENTS IN THE JOINT WARFARE
ANALYSIS EXPERIMENTAL PROTOTYPE**

by

19960404 038

Thomas J. Wilk
September 1995

Thesis Advisor

Samuel H. Parry

Approved for public release; Distribution is unlimited

REPORT DOCUMENTATION PAGE

Form Approved
OMB No. 0704-0188

Public reporting burden for this collection of information is estimated to average 1 hour per response, including the time for reviewing instructions, searching existing data sources, gathering and maintaining the data needed, and completing and reviewing the collection of information. Send comments regarding this burden estimate or any other aspect of this collection of information, including suggestions for reducing this burden to Washington Headquarters Services, Directorate for Information Operations and Reports, 1215 Jefferson Davis Highway, Suite 1204, Arlington, VA 22202-4302, and to the Office of Management and Budget, Paperwork Reduction Project (0704-0188), Washington, DC 20503.

1. AGENCY USE ONLY (Leave Blank)		2. REPORT DATE September 1995	3. REPORT TYPE AND DATES COVERED Master's Thesis	
4. TITLE AND SUBTITLE THEATER LEVEL OPERATIONS: MODELING GROUND UNIT LOGISTICAL REQUIREMENTS IN THE JOINT WARFARE ANALYSIS EXPERIMENTAL PROTOTYPE (U)			5. FUNDING NUMBERS	
6. AUTHOR(S) Wilk, Thomas J.				
7. PERFORMING ORGANIZATION NAME(S) AND ADDRESS(ES) Naval Postgraduate School Monterey, CA 93943-5000			8. PERFORMING ORGANIZATION REPORT NUMBER	
9. SPONSORING / MONITORING AGENCY NAME(S) AND ADDRESS(ES)			10. SPONSORING / MONITORING AGENCY REPORT NUMBER	
11. SUPPLEMENTARY NOTES The views expressed in this thesis are those of the author and do not reflect the official policy or position of the Department of Defense or the U.S. Government.				
12a. DISTRIBUTION / AVAILABILITY STATEMENT Approved for public release, distribution is unlimited			12b. DISTRIBUTION CODE	
13. ABSTRACT (Maximum 200 words) This study proposes a methodology for modeling the logistics processes for ground units in the Joint Warfare Analysis Experimental Prototype (JWAEP) simulation. The model structure presented in this research allows for the representation of the consumption, movement, and distribution of supplies within the combat units modeled in JWAEP. Also presented is an architecture to model logistical units in JWAEP. Methodologies are presented to model both the "push" and "pull" systems of supply. The supply network modeled in this thesis allows for the emplacement of multiple support units into the existing JWAEP arc-node network, permitting the influx of supplies to theater supply points and the transferal of these supplies to intermediate and terminal supply points along the arcs of the network. This logistical model structure also acts to constrain the units represented in JWAEP by limiting their supply stocks to more realistic levels. The thesis also presents the methodology and algorithms to allow the use of the logistical structure as a planning constraint on the decision maker's courses of action. A decision maker's courses of action may be limited by the availability of supplies required to execute those courses of action. The effect of this limitation is to cause the decision maker to choose among courses of action that may be only partially supportable, and therefore involve more risk.				
14. SUBJECT TERMS Stochastic, Theater Logistics Model, Joint Warfare Experimental Prototype, JWAEP, Logistics, Theater Model, Campaign Model, Operational Model, Combat Simulation			15. NUMBER OF PAGES 107	
			16. PRICE CODE	
17. SECURITY CLASSIFICATION OF REPORT Unclassified	18. SECURITY CLASSIFICATION OF THIS PAGE Unclassified	19. SECURITY CLASSIFICATION OF ABSTRACT Unclassified	20. LIMITATION OF ABSTRACT UL	

Approved for public release; distribution is unlimited

**THEATER LEVEL OPERATIONS: MODELING GROUND UNIT
LOGISTICAL REQUIREMENTS IN THE JOINT WARFARE ANALYSIS
EXPERIMENTAL PROTOTYPE**

Thomas J. Wilk
Captain, United States Army
B.S., United States Military Academy, 1986

Submitted in partial fulfillment of the
requirements for the degree of

MASTER OF SCIENCE IN OPERATIONS RESEARCH

from the

**NAVAL POSTGRADUATE SCHOOL
September 1995**

Author: _____



Thomas J. Wilk

Approved by: _____

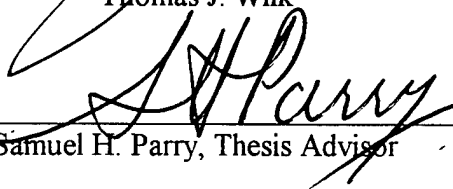

Samuel H. Parry, Thesis Advisor



Mark A. Youngren, Second Reader

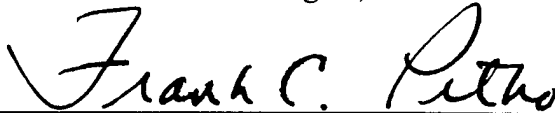

Frank C. Petho, Chairman,
Department of Operations Research

ABSTRACT

This study proposes a methodology for modeling the logistics processes for ground units in the Joint Warfare Analysis Experimental Prototype (JWAEP) simulation. The model structure presented in this research allows for the representation of the consumption, movement, and distribution of supplies within the combat units modeled in JWAEP. Also presented is an architecture to model logistical units in JWAEP. Methodologies are presented to model both the "push" and "pull" systems of supply. The supply network modeled in this thesis allows for the emplacement of multiple support units into the existing JWAEP arc-node network, permitting the influx of supplies to theater supply points and the transferal of these supplies to intermediate and terminal supply points along the arcs of the network. This logistical model structure also acts to constrain the units represented in JWAEP by limiting their supply stocks to more realistic levels.

The thesis also presents the methodology and algorithms to allow the use of the logistical structure as a planning constraint on the decision maker's courses of action. A decision maker's courses of action may be limited by the availability of supplies required to execute those courses of action. The effect of this limitation is to cause the decision maker to choose among courses of action that may be only partially supportable, and therefore involve more risk.

TABLE OF CONTENTS

I.	INTRODUCTION	1
	A. OVERVIEW	1
	B. PROBLEM	2
	C. RESEARCH OBJECTIVES	3
	D. ASSUMPTIONS	4
	E. LIMITATIONS	5
	F. SCOPE	5
	G. SUMMARY OF CONTENTS	6
II.	REVIEW OF CURRENT MODELS	7
	A. GENERAL	7
	B. JOINT WARFARE ANALYSIS EXPERIMENTAL PROTOTYPE (JWAEP)	7
	C. CONCEPTS EVALUATION MODEL (CEM)	7
	1. Background	7
	2. Representation of Logistic Structure	9
	D. TACWAR	10
	1. Background	10
	2. Representation of Logistic Structure	10
	E. VECTOR IN COMMANDER (VIC)	11
	1. Background	11
	2. Representation of Logistic Structure	11
	F. FASTORS	12
	1. Background	12
	2. Methodology	12
	G. THUNDER	13
	1. Background	13
	2. Representation of Air Attrition to Logistics	13

III.	METHODOLOGY FOR MODELING UNIT LOGISTICS	15
	A. GENERAL	15
	B. DESCRIPTION OF THE SUPPLY NETWORK	15
	C. REPRESENTATION OF UNITS	17
	1. Review of the JWAEP Architecture	17
	2. Basic Load Databases	20
	3. Terminal Supply Points (BSAs)	22
	4. Intermediate Supply Points (DSAs and CSAs)	30
	5. Theater Supply Points	32
	D. MATERIAL HANDLING EQUIPMENT (MHE)	34
	E. CONSUMPTION OF SUPPLIES	36
	F. TRANSPORTATION AND RESUPPLY	38
	1. Into Theater	38
	2. Within Theater	39
	G. EXTENSIONS OF THE BASIC STRUCTURE	41
	1. Medical and Maintenance Systems	41
	2. Rail and Ship Movement	42
IV.	METHODOLOGY FOR MODELING LOGISTICAL CONSTRAINTS ON COURSES OF ACTION	43
	A. GENERAL	43
	B. LOGISTICS STRENGTH PARAMETERS	43
	1. Mechanized Brigade Basic Load Equivalent (MBLE)	43
	2. Ammunition (LAM) and POL (LPO)	44
	3. Surface Transport (LST) and Air Transport (LAT)	46
	C. ESTABLISHING UNIT PRIORITIES	46
	1. Combat Unit Priorities	47
	2. Terminal Support Unit Priorities	49
	3. Intermediate Support Unit Priorities	50
	4. Theater Support Unit Priorities	50
	D. CALCULATING COST FROM SUPPLIER TO CUSTOMER	51

E.	RESUPPLY REQUESTS	52
1.	The Push System	53
2.	The Pull System	53
3.	Filling Supply Requests	54
F.	LOGISTICAL FEASIBILITY	59
1.	Expected Amount of Supplies On Hand at End of Resupply Time ..	62
2.	Logistical Feasibility	63
V.	TESTING THE METHODOLOGY	69
A.	GENERAL	69
B.	SCENARIOS FOR INVESTIGATION	69
C.	ASSUMPTIONS	70
D.	ANALYSIS	70
E.	RESULTS	70
1.	Priority Values	71
2.	Logistical Feasibility Matrices	71
VI.	CONCLUSIONS AND FUTURE STUDY	75
A.	CONCLUSIONS	75
B.	FUTURE STUDY	76
	APPENDIX	77
	LIST OF REFERENCES	87
	INITIAL DISTRIBUTION LIST	89

EXECUTIVE SUMMARY

The *Joint Warfare Analysis Experimental Prototype* (JWAEP) model is an interactive, two-sided, theater level combat experimental model based on an arc-node representation of ground and air combat. The model can be used in an interactive gaming mode or a closed-form stochastic mode. The current version (1.2) of the JWAEP model does not explicitly model the logistics capabilities of the combat forces. Previous versions maintained three classes of supplies as place holders for each combatant in JWAEP — POL, ammunition, and other, but these place holders held no information with respect to what supplies units have "on-hand." It is necessary to include a model of the ground support logistical structure in any modern combat simulation for the analyst to assess the effects that constrained supply capabilities may have on combat units and their ability to accomplish a given military objective.

The focus of this research is to develop the methodology and algorithms necessary to establish a logistical structure for the JWAEP model, and to give it the capability to use this logistical structure as a tool that aids the decision maker in choosing a course of action.

The first objective of this thesis is to present an approach to modeling a logistical structure which permits supplies to be delivered into theater and transported forward from support units to combat units. Inherent in this architecture are algorithms that allow units to consume, move, and restock supplies both on a routine and an emergency basis. Additionally, this structure allows the logistical network of the model to act as a physical constraint on units by degrading their capabilities when units are critically short of supplies.

The second objective of the thesis is to develop the methodology and algorithms that allow the use of the logistical structure as a planning constraint on the decision maker's available courses of action. The decision maker may have several courses of action available operationally, but may not be able to support one or more of them logistically. This potentially drives the decision maker to choose among courses of action which may be logistically supportable, or partially supportable, to best accomplish the mission. The

logistical model may also be used by the decision maker to infer the perceived logistics feasibility for possible enemy operations.

In the case of logistical units some modifications and additions to the current JWAEP architecture are necessary to define how logistical units work and what equipment they have. As with combat units, the support unit types must be defined. There are three additional unit types to be defined in the JWAEP model: theater or depot supply points, intermediate supply points, and terminal supply points. In terms of current U.S. doctrine the theater unit type coincides with depots, rail and road heads, and sea or air ports of debarkation; intermediate supply points are both Corps Support Areas (CSA) and Division Support Areas (DSA); terminal supply points are Brigade Support Areas (BSA).

The supply network to be modeled for JWAEP allows for the emplacement of multiple support units into the existing arc-node network. These support units allow for the influx of supplies into theater supply points at ground depots, sea ports or air ports of debarkation (SPOD or APOD), and for the transferal of these supplies to CSAs, DSAs, and finally BSAs by truck convoy, rail, or aircraft along the arcs of the network. Once supplies reach the BSAs they are considered to be available for immediate consumption by combat units without further delay.

Two databases must be established: one to hold the predetermined basic load for each weapon system included in the model, and a second to hold the scenario data for each unit. The scenario database contains information on the quantity of supplies currently in the unit, the quantity of supplies necessary to fill a basic load for the unit, and what percent of basic load is available to the unit currently. This database is where the consumed supplies are decremented and arriving supplies are incremented to the unit's on-hand supplies.

Similar to the *atcal.type.eq* file already present in the current JWAEP model, a *log.type.eq* file must be included that defines all the type equipment included in the logistical units. For the purposes of the initial model described in this thesis, this will only include ground conveyance type vehicles such as trucks. Future versions of the model may incorporate aircraft, rail equipment, and sea going vessels such as ships, barges, etc. An

additional requirement for supply units at all levels is the need for material handling equipment (MHE) such as forklifts, cranes, etc., and personnel to operate these pieces of equipment.

In its broadest sense, the logistics structure proposed for the JWAEP model acts as a constraint on the units within the model by placing limits on the amount of supplies that units can consume, request, carry, and receive. The proposed model, even in a rough form, is much more realistic than the current model of infinite supply. The additional proposals presented in this thesis create a more realistic logistical structure by relating decisions that concern unit resupply and course of action feasibility to the logistical model.

Four aggregated strength parameters are proposed to hold the logistic strength characteristics of the individual units. These four parameters are:

- Ammunition
- POL
- Surface Transport
- Air Transport

These logistics strength parameters are intended for use in the decision making process of the model as estimates of friendly and enemy logistical strength capabilities. These parameters are the foundation for the second part of the thesis which allows for estimates of the logistical supportability of courses of action.

All ground units are prioritized by the logistical model in order to make logistical decisions. Units are prioritized starting at the lowest level of unit representation. Priorities for the successive echelons are established based upon those priorities set at the levels below them, with the terminal support level as the lowest and theater support level as highest. In all cases, a higher priority value for a unit gives the unit priority over the other customers supported by its direct supplier.

Before a support unit is able to establish convoys and deliver supplies to its customers, it must have the following information for all of its customers:

- Priority values.
- Resupply request values.
- Supply system descriptors.

- Distance from the support unit.

Using this information, support units begin to apportion their supplies and trucks available by giving additional weight to those customers using the “pull” system. The purpose of this weight is to increase the priority values of those customers using the “pull” system, since they are considered to be critically short of supplies, either due to a change in mission assignment or heavy consumption. All the customers (“push” and “pull”) are then placed into a single priority queue, using their priority values as the discriminator.

Depending upon the supplies on hand, trucks available, and the Material Handling Equipment (MHE) available at the support unit along with the time required to execute a single convoy to each customer, the potential exists in both the “push” and “pull” systems for the support unit to run continuous convoys to all or some of its customers in order to completely fill a supply request. Due to this potential, logistics processes operate on a cycle at each echelon of support. Supply requests are re-evaluated at the beginning of each cycle, such that any portion of a customer’s supply request not filled in a single cycle will be included in the customer’s request for the next cycle, as long as the customer continues to have the same requirements and priority. Cycle lengths at each support echelon are left to the user’s discretion.

Calculating the logistical feasibility of a course of action allows the decision maker to determine whether a course of action is supportable and to quantify the amount of risk involved in a course of action, in terms of the ratio of supplies available to supplies required.

A logistical course of action for a support unit is described by the combat assignments for all of its customers. As a review, only combat units and terminal support units are given mission orders; e.g., attack, defend, delay, etc. As it pertains to a combat unit, a course of action in the JWAEP model is described by a mission order and a set of arcs and nodes upon which to conduct the mission. Logistical courses of action for a support unit differ only by the mission orders given to its customers.

When comparing logistical courses of action for feasibility, the decision maker is attempting to determine the probability that a customer’s requirements can be met to a certain degree, under given conditions. The feasibility of a course of action is quantified as the

probability that a customer can have a given proportion of its required supplies on hand by a specified time. The proportions are specified by the user and are an attempt to quantify the amount of logistical risk involved for each customer under a logistical course of action.

The focus of this study is to develop the methodologies and algorithms needed to portray the logistical processes in the JWAEP simulation. The methods developed in this thesis are intended to create a more robust representation of JWAEP as a theater combat simulation. Future studies can use the architecture developed in this thesis to investigate theater logistical requirements and to quantify the effects of logistical constraints on theater combat operations.

I. INTRODUCTION

A. OVERVIEW

In its broadest sense logistics is defined by the U.S. Department of Defense as:

The science of planning and carrying out the movement and maintenance of forces...including those aspects of military operations which deal with design and development, acquisition, storage, movement, distribution, maintenance, evacuation, and disposition of materiel; the movement, evacuation and hospitalization of personnel; the acquisition or construction, maintenance, operation, and disposition of facilities; and the acquisition or furnishing of services. [Ref. 1]

Logistics is an element of combat power at the operational level. Operational logistics involves the sustainment planned and executed to support the joint theater force. It includes manning, arming, fueling, fixing, and transporting the theater force, along with protecting the logistical system from attack. [Ref. 2]

At the tactical level, sustainment involves the activity of providing ammunition, fuel, food and water, maintenance, transportation, personnel and medical support to tactical units in support of battles and engagements. [Ref. 2]

One of the most difficult decisions to make when modeling logistical operations is determining the best level of resolution to represent. Logistical operations are rich with different potential processes that may be modeled at the theater level. These processes range from the movement of organic divisional transportation assets and coalition sea transport, to host nation rail networks and commercial civilian contracts for trucks and supplies. It is easy to understand how some models collapse of their own weight by attempting to represent too much of the logistical structure. On the other hand, a model may not be considered valid if it does not yield somewhat realistic results, produced under rules and limitations that adequately describe the logistical process in military operations.

Most theater level combat simulations currently in use by the U.S. military include a model for estimating the logistical play of units involved in the simulation. For example,

some of the most essential estimates derived from the Concepts Evaluation Model, used at the U.S. Army Concepts Analysis Agency, are the estimates for the amount of supplies consumed by the units in theater during simulation runs. From these estimates, analysts and decision makers can develop recommendations and decisions pertaining to the number and types of units to send into a theater of operations, and they receive an expectation for the logistics flow necessary to sustain combat at the simulated levels of intensity.

B. PROBLEM

The *Joint Warfare Analysis Experimental Prototype* (JWAEP) model is an interactive, two-sided, theater level combat experimental model based on an arc-node representation of ground and air combat. The model is capable of use in an interactive gaming mode or a closed-form stochastic mode. The current version (1.2) of the JWAEP model does not explicitly model the logistics capabilities of the combat forces. Previous versions maintained three classes of supplies as place holders for each combatant in JWAEP — POL, ammunition, and other, but these place holders held no information with respect to what supplies units have "on-hand." The current version of JWAEP has no logistical structure at all. It is necessary to include a model of the theater army logistical structure in any modern combat simulation for the analyst to assess the effects that constrained supply capabilities may have on combat units and their ability to accomplish a given military objective.

A logistical structure for the JWAEP model must allow for several operations to occur. These operations (which must be explicitly represented) may be described in broad terms as consumption, movement, and distribution of supplies. Some of the implicit questions that must also be addressed by a logistics model are: Who consumes, moves, and distributes supplies? What are the classes of supply that are to be modeled? How much of these supplies do consumers have? What are the constraints placed upon these logistical operations, and how might they be degraded? The algorithms recommended to answer these questions and establish the basic logistical structure of the JWAEP model are the foundation of this thesis.

C. RESEARCH OBJECTIVES

The focus of this research is to develop the methodology and algorithms necessary to establish a logistical structure for the JWAEP model, and to give the JWAEP model the capability to use this logistical structure as a planning constraint on the decision maker's courses of action.

The first objective of this thesis is to present an approach to modeling the logistical structure that permits supplies to be delivered into theater and transported forward from support units to combat units. Inherent in this architecture are algorithms that allow units to consume, move and restock supplies both on a routine and an emergency basis. Additionally, this structure allows the logistical network of the model to act as a physical constraint on units by degrading their capabilities when units are critically short of supplies.

To incorporate a logistical model into JWAEP, it was first necessary to break down the problem into subobjectives. These subobjectives specify:

- logistical units necessary to include in the model,
- types and amounts of equipment organic to the logistical units,
- capacities of logistics equipment for transport of supplies,
- types of supplies to be modeled,
- basic loads and days of supply on-hand for all maneuver and logistical units across all supply classes in the simulation,
- transportation and transshipment rates for logistics operations on the different classes of arcs and nodes of the model, and
- algorithms to model both a push system of supply and a pull (requisition) system of supply.

The model will initially set up a push system, where all supplies are automatically transported to the units according to a pre-established forecast, without being requisitioned. This is entirely realistic since much of the ground resupply doctrine in the U.S. Army is conducted using a push system. As the model matures, algorithms may be

added so that units may be resupplied with certain classes of supplies only upon requisition. The model also allows for a pull system when unit supplies fall below a critical threshold.

The second segment of the thesis develops the methodology and algorithms that allow the use of the logistical structure as a planning constraint on the decision maker's available courses of action. The decision maker may have several courses of action available operationally, but may not be able to support one or more of them logistically. This potentially drives the decision maker to choose among courses of action that may be logistically supportable to best accomplish the mission.

The subobjectives for this segment of the thesis are to:

- Develop a methodology which allows the decision maker to estimate the amount of supplies necessary to support a potential course of action, and estimates the logistical supportability of these courses of action, given the current conditions of the scenario (e.g., location of support units, available stocks of supplies on-hand, available time and equipment to transport additional supplies, etc.).
- Determine measures of performance that describe levels of logistical supportability which enhance the decision logic of the current JWAEP model by incorporating logistical operations into course of action decisions.
- Determine areas of future research and improvement of the model.

D. ASSUMPTIONS

The assumptions applicable to this research are described below.

- The algorithms developed to model a logistics network in the JWAEP model can be coded and incorporated into the simulation without slowing its execution, and can be directly incorporated into the present arc-node movement terrain network without having to add an additional arc-node structure.
- The Attrition Calibration / Combat Sample Generator (ATCAL / COSAGE) model maintained by the U.S. Army Concepts Analysis Agency will estimate the supply consumption rates and the "bean-counting" of supplies used by each element on both sides

(which can be aggregated to the unit level over all supply items introduced into theater) which will be transferred into the JWAEP model for use in the dynamic logistics calculations.

- The ATCAL / COSAGE model will deliver dynamic data that will yield number of soldiers wounded and evacuated to field hospitals, and weapon systems, by type, that may be repaired.
- Transportation truck units will use the same movement criteria as combat units already in the model.
- Supply stockpiles, which are located at supply nodes, are automatically composed of the correct proportional mix of supplies needed by the supply nodes to support its customers.

E. LIMITATIONS

The logistical model suggested for this research will only model the ground logistical architecture for a theater of operations. Airbase and air force unit resupply are not considered. The model is described in terms of U.S. military doctrine; however, using the concepts of theater, intermediate, and terminal supply points, it may be applied to any non-U.S. or enemy force. Due to the similarities involved in the algorithms for multiple classes of supply, this research will only model one supply class, ammunition. Other supply classes may be included in future development. It is not the intent of this research to develop algorithms that optimize the supply network, but to model a logistics network capable of simulating current doctrine. No effort is made to model, or to optimize the transport of supplies from point of origin (e.g., the United States) into theater. All supplies for the supply depots and ports will arrive from a "source node" after a pre-determined delay to account for transport. [Ref. 3]

F. SCOPE

The primary emphasis of the research was to develop the algorithms that may be incorporated into the JWAEP model to establish a working logistics structure that allows for the introduction of supplies into theater, and the movement of supplies from the points of introduction to the combat units that will consume them. This logistical structure

allows for supplies to be transported by truck convoy along the JWAEP road network, and allows convoy units to be destroyed or delayed by opposing forces or by unfavorable travel conditions. Additionally, the logistics structure allows for the degradation of combat units due to supply constraints and the use of the supply network to determine the logistical supportability of the decision maker's courses of action. Extensions of the basic model are dependent upon future research as indicated in Chapter VI.

G. SUMMARY OF CONTENTS

Chapter II is a review of several theater level combat simulations and the methodology used in each with respect to modeling logistics operations. The review also includes an overview of the current version of JWAEP.

Chapter III describes the methodology proposed for the logistical structure for the JWAEP model. This chapter defines the associated databases and data structures necessary to provide for the representation of theater level logistics processes. Also included are descriptions of methods to extend the basic model to include medical, maintenance, rail network, and ship movement capabilities.

Chapter IV outlines the methodology and algorithms needed to create a more realistic logistical architecture for JWAEP by tying together maneuver courses of action and the logistical feasibility of those courses of action. Logistical strength parameters are described as estimates of unit logistical capabilities. This chapter also describes methods to establish unit priorities for customers of supply units at each support echelon.

Chapter V presents an analytical spreadsheet model used to examine the reasonableness of the methodologies developed in Chapter IV. Specifically, the areas examined are the algorithms that establish unit priorities, fill resupply requests, and find the logistical feasibility of courses of action.

Chapter VI summarizes the thesis and discusses areas of future research.

II. REVIEW OF CURRENT MODELS

A. GENERAL

The simulation models included in this review present different modeling techniques used to represent the logistics operations in a theater level combat model. A review of the air attrition model for logistics is also included. A JWAEP model summary is presented as background to the reader unfamiliar with its uses and current development status.

B. JOINT WARFARE ANALYSIS EXPERIMENTAL PROTOTYPE (JWAEP)

The *Joint Warfare Analysis Experimental Prototype* (JWAEP) model is an interactive, two-sided, theater level combat experimental model based on an arc-node representation of ground and air combat. The model is capable of use in an interactive gaming mode or a closed-form stochastic mode. Unit representation may be at the battalion or brigade level for ground combat, flight groups, and major combat vessels. JWAEP is a software prototype developed by the Naval Postgraduate School for research and experimentation into stochastic decision-making and C³I approaches to theater level modeling. [Ref. 4]

Ground warfare is executed in JWAEP upon the arc-node representation of the key terrain, objectives, defensive points and maneuver corridors. Units have the ability to move anywhere in the network in accordance with appropriate movement rates and terrain restrictions respective to the size and maneuver capabilities of each unit. Attrition is deterministic and is assessed through the COSAGE/ATCAL process developed at the U.S. Army Concepts Analysis Agency.

C. CONCEPTS EVALUATION MODEL (CEM)

1. Background

The *Concepts Evaluation Model* (CEM) VII used at the U.S. Army Concept Analysis Agency (CAA) is the most current version of the model in use. The model is completely deterministic and was developed initially in 1968 at the Research Analysis Corporation as the Theater Combat Force Requirements Model (TCM). The purpose of

the TCM was to provide the Army staff with a simulation sensitive to different mixes of combat units on both sides that could mirror theater level command decisions and their impact on missions and the allocation of resources. The model eventually became known as the Conceptual Design for the Army in the Field (CONAF) Evaluation Model I (CEM I). [Ref. 5]

The original model was modified several times before being transferred to the CAA in 1974 as CEM IV. At CAA, the model took on its current name, Concepts Evaluation Model, and has since undergone three additional stages of major modifications. It has been executed over 1000 times in support of the studies conducted at CAA. These studies include the Total Army Analysis studies conducted annually to analyze the support force structure requirements for the Army, and the Army materiel requirement studies. [Ref. 5]

Similar to the JWAEP model, CEM VII uses the ATCAL attrition model to calculate combat attrition. The primary inputs for the model are the forces and resources allocated in theater by the opposing sides and information pertaining to the outcomes from brigade-level engagements.¹ The resulting outputs are the location and thus movement of the Forward Line Of Troops (FLOT) and the status of the units present in the scenario as evaluated from the levels of resources remaining in the units, accounting for consumption and resupply. [Ref. 5]

CEM simulates the battlefield by separating terrain into sectors or pistons along which engagements occur. Forces in combat become attrited and replenished resulting in the shifting of the FLOT within each sector. Echelons of command from brigade to theater have an associated time period, or cycle, during which missions are executed. Changes in mission occur at the end of these cycles when the different levels of command evaluate their status. The time periods associated with each echelon are: brigade, 6 hours; division, 12 hours; corps, 24 hours; army, 48 hours; theater, 96 hours. For a more

¹ The brigade-level engagement data is output from a high-resolution stochastic simulation called COSAGE; thus the attrition process is sometime referred to as ATCAL / COSAGE.

complete review of CEM VII the reader is referred to Volume I - Technical Description. [Ref. 5]

As a replacement to CEM, CAA developed FORCEM in the early 1980's. This model included a very high resolution representation of the logistics and maintenance processes for a theater level model. The model was developed internally to CAA, and eventually was no longer used after 1991 due in part to its overly cumbersome logistics model. [Ref. 5]

2. Representation of Logistic Structure

There are four basic logistical areas represented in CEM: supply, maintenance, personnel support and transportation. These areas may be broken down further depending upon the logistical function being modeled. The supply area considers five different categories which include POL, ammunition, other supplies, major equipment replacements and personnel replacements. Each of these classes is handled independently, and in the case of ammunition, it is further divided into artillery and maneuver battalion ammunition. Personnel replacements may also be broken down into three different nationalities for the blue side. The maintenance function models nonfunctioning tanks, light armored vehicles, and attack helicopters in a simulated maintenance loop which is controlled by three parameters. These parameters are the proportion of vehicles repaired, the repair capacity of the supporting units, and the repair time necessary for each type of system. Systems that are repaired are returned to the theater distribution pool. The personnel support area is similar to the maintenance system in that it is also modeled as a loop. Combat wounded patients are evacuated to the general hospital system and are returned to the theater personnel distribution pools after a given time, which is based upon the theater medical evacuation policy. Finally, the transportation area is modeled with parameters of capacity and movement rate for each of the five supply categories. The capacity constraint is modeled in a post-processor, but the movement rates are simulated by time delays imposed as a function of the tactical environment. [Ref. 5]

At the beginning of each theater cycle, new resources are made available and are placed in theater distribution pools. After a time delay associated with transportation and

processing, the resources are placed in the distribution pools and made available to the respective division and brigade forces during their respective time cycles, based upon the needs of the units. Units carry descriptive parameters for authorized strength, equipment and initial supplies on-hand. Each of these parameters also has an associated parameter for its current status. Resources are provided to units based upon the needs of the units to replace losses and the availability of the resources in the theater distribution pool. [Ref. 5]

D. TACWAR

1. Background

The *Tactical Warfare* combat model (TACWAR) is a deterministic model used to model air and ground combat at the theater-level. The model is capable of simulating combat using conventional and chemical weapons. TACWAR was developed by the Institute of Defense Analysis based on experiences from a collection of combat models including ATLAS, IDAGAM, IDAHEX, and others. TACWAR is used extensively at the Joint Staff, the United States Central Command, and other unified commands. [Ref. 7]

2. Representation of Logistic Structure

TACWAR uses a Logistics Submodel to simulate the various supply operations necessary to support combat units. The basic structure of the Logistics Submodel is a network of arcs and nodes, with the nodes representing the different types of supply distribution points included in the model. These supply distribution points may be sea ports, Aerial Ports of Debarkation (APOD), supply depots, Corps Support Areas (CSA), Division Support Areas (DSA), or airbases. The number and type of supply nodes included in a scenario are decided by the user along with the number and size of customers that each node will support. Each node is placed within a specified zone in the scenario and distribution is carried out from supply nodes to customers by convoys along the arcs of the network. [Ref. 8]

The types of resources that are represented in TACWAR are ground and air supplies, equipment, personnel, and trucks. Ground supplies are those resources that sustain combat units and distribution points. They are further broken down into food, fuel, ammunition, repair parts, and medical items. Air supplies include aircraft munitions

and aircraft repair parts. TACWAR additionally allows the user to designate supplies which may be used as both ground and air supplies, and models material handling equipment and personnel available at supply nodes to determine the capacity of supply operations that can be accomplished at a node. [Ref. 8] For example, suppose a fully loaded ship is at a port, and it takes 50 people to unload 1,000 tons of supplies per day. If there are only 40 people present at the port, then the port may only work at 80% capacity. At this capacity, only 800 tons of supplies can be unloaded per day.

E. VECTOR IN COMMANDER (VIC)

1. Background

The *Vector-In-Commander* (VIC) combat model is a deterministic two-sided simulation developed in 1982 to represent combined arms combat at the U.S. Army Corps level. VIC is the result of a combination of two previous models, a ground combat model called *Vector-2*, and an Air Force combat model named *Commander*. In developing VIC the Bonder-Farrel mathematical representations of ground combat from the *Vector-2* model were embedded into the event driven structure of *Commander*. [Ref. 9]

2. Representation of Logistic Structure

VIC is a modular simulation written in SIMSCRIPT II.5. Logistics functions are controlled by two modules. The LOGISTICS module handles all CSS functions in the model except for medical and maintenance operations. Medical and maintenance functions are controlled by the RETURN TO DUTY module. The specific classes of supply represented are ammunition, POL, and any other supply class which the user chooses to account for explicitly. Repair parts are treated as a type of ammunition which is supplied to the maintenance units. The basic structure is such that units begin the simulation with an initial basic load of supplies. Once a supply category within a unit has been consumed down to a pre-determined threshold, the unit generates a request for resupply from its forward supply point. The forward supply point fills the requisition and may likewise request resupply from its supply point, etc. The system replicates itself in this manner up to the main supply point. The simulation models movement of supplies by modeling vehicle convoys on the model's terrain grid. Both the supply points and convoys

are subject to attrition. The simulation also models emergency resupply using lift helicopters. [Ref. 10]

The RETURN TO DUTY module handles maintenance and medical systems by permitting wounded personnel and repairable vehicles to be recovered and returned to field hospitals and maintenance points. After a delay these items are either reissued to units or returned to distribution pools for later reissue. [Ref. 10]

F. FASTORS

1. Background

As part of its Total Army Analysis Review for Fiscal Year 1995, the U.S. Army Concepts Analysis Agency (CAA) was directed by the Chief of Staff of the Army to analyze the U.S. Army's requirements for the "below the line" forces necessary to deploy into potential theaters of Operations Other Than War. "Below the line" forces refer to support units not normally deployed for use in active combat. The missions which the CAA studied were outlined by the Illustrative Planning Scenarios included in the Defense Planning Guidance for 1995. [Ref. 11]

Subject matter experts from within CAA and from the U.S. Army Branch Schools representing the Combat, Combat Support, and Combat Service Support Arms gathered to attend a one week workshop to discuss the type units, number of personnel and type equipment, and type of tasks deployed units would perform during each of the Illustrative Planning Scenarios. The result of this workshop is the FASTORS model. The FASTORS model is a spreadsheet model created in *Microsoft EXCEL*[®] at CAA. [Ref. 11]

2. Methodology

In the FASTORS spreadsheet model, the number and types of units generated for the trooplist are calculated according to a specific set of rules that fall under one of two categories — Existence Rules and Workload Rules. An Existence Rule applies when there is a direct doctrinal or organizational rule that causes a unit to be added to the list. For example, when an Infantry Brigade deploys to a theater of operations for an extended period of time (greater than fifteen days) the Forward Support Battalion that provides direct support to that brigade also deploys. A Workload Rule applies when a unit is added

to the trooplist, based upon a set of requirements in theater. These requirements are based upon units that are already slated to deploy which require additional support, or based upon missions either explicitly or implicitly directed by the mission statement. An example of a Workload Rule in an OOTW scenario may be for a Water Purification Team. In this example, the number of teams to deploy into theater is based upon the number short tons of water consumed per day by the total force deployed. The FASTORS Spreadsheet model developed at the U.S. Army Concepts Analysis Agency has been used within that agency to generate a trooplist for U.S. Army units necessary for deployment into theater for potential OOTW missions. [Ref. 11]

G. THUNDER

1. Background

THUNDER is a two-sided combat model developed at the Air Force Studies and Analyses Agency to simulate conventional theater level warfare. The model was primarily designed to simulate air combat; however, it includes a ground combat model based upon the CEM model. *THUNDER* has been in use since 1986 and is capable of simulating theater level combat in any location, provided an adequate terrain data base exists. [Ref. 12]

2. Representation of Air Attrition to Logistics

THUNDER represents five different classes of supply for ground combat operations: equipment, ammunition, POL, dry bulk, and water. Logistics facilities, transshipment points, and supply trains make up the basic structure of the logistics model, and each of these three entities may be reduced by air attrition. [Ref. 12]

Logistics facilities include two components which affect their supply capability: issue capacity and supplies. Issue capacity reflects the maximum amount of supplies that the facility is capable of issuing daily, as constrained by the number of trucks or handling equipment on-hand. Supplies reflect the total holding capacity of a supply class for the facility, and an additional parameter for the total amount of the supply class on-hand. Destruction of a facility's supplies or issue capacity impacts the facility's capability to

supply its customer's requirements, and thus the combat potential of the combat units supplied. [Ref. 12]

Transshipment points represent those logistics facilities where supplies are transferred from one mode of transportation to another along a transshipment arc. These points may be seaports, airports or railheads. Capacities of transshipment points and arcs may be reduced by aerial destruction of the elements that move supplies along the respective arcs. [Ref. 12]

Supply trains represent elements such as trucks, trains, and ships which move supplies along the supply network of the model. Losses of supplies due to air attack are calculated as a function of the proportion of elements in the supply train that were destroyed and the amount of supplies carried in the supply train prior to the attack. A supply train always travels to its destination; however, it may be delayed or, if destroyed, it may deliver nothing. [Ref. 12]

III. METHODOLOGY FOR MODELING UNIT LOGISTICS

A. GENERAL

The central elements of information already included in the JWAEP model that may be used or modified both to establish the logistical structure and to define new logistical units are: [Ref. 4]

- Unit identification number.
- Unit name.
- Unit side.
- Unit type number.
- Maximum support range.
- Equipment identification number.
- Equipment quantity and standard deviation.
- Equipment weight in short tons.
- Weapon identification number.
- Weapon ammunition weight in lbs. / round.

In the case of logistical units some modifications and additions are necessary to define how these units work and what equipment they have. As with combat units, the support unit types must be defined. There are three new unit types to be defined in the JWAEP model: theater or depot supply points, intermediate supply points, and terminal supply points. In terms of current U.S. doctrine the theater unit type coincides with depots, rail and road heads, sea or air ports of debarkation; intermediate supply points including both Corps Support Areas (CSA), and Division Support Areas (DSA); terminal supply points which are Brigade Support Areas (BSA). These unit types must be defined by the user for each side in the simulation.

B. DESCRIPTION OF THE SUPPLY NETWORK

The supply network to be modeled for JWAEP allows for the emplacement of multiple support units into the existing arc-node network. These support units allow for the influx of supplies into theater supply points at ground depots, sea ports or air ports of

debarkation (SPOD or APOD), and for the transferal of these supplies to CSAs, DSAs, and finally BSAs by truck convoy, rail, or aircraft along the arcs of the network. Once supplies reach the BSAs they are considered to be available for immediate consumption by combat units without further delay. Figure 1 illustrates the supply network.

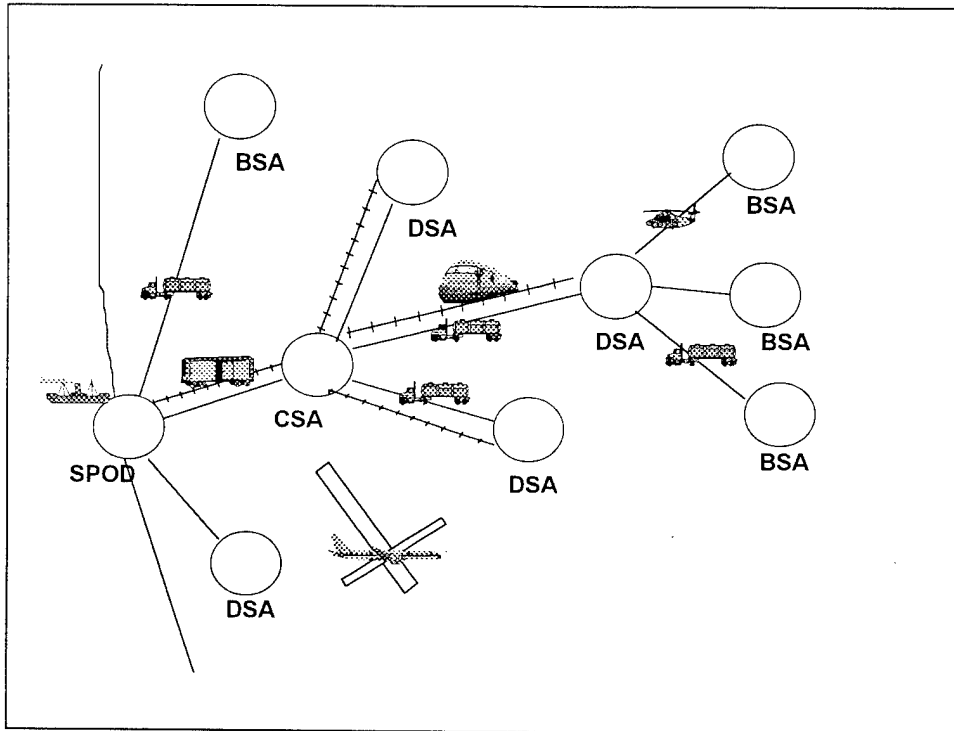

Figure 1. Supply Network.

Within the model, combat units are assigned as customers to one of the support unit types, along with lower echelon support units. A lower echelon support unit type may be assigned as a customer to a support unit type of any echelon above it. For example, BSAs may be customers of any support unit type except another BSA; DSAs may be supported by either a CSA or a depot supply point, etc. Additionally, separate units within the model such as non-divisional combat brigades or battalions may be assigned as customers to any type support unit. Table 1 is a matrix of the logistics nodes and the type units they may support in the JWAEP model.

Theater Supply Points	Intermediate Supply Points		Terminal Supply Points
<i>Depot or Port</i>	<i>Corps Support Area</i>	<i>Division Support Area</i>	<i>Brigade Support Area</i>
Corps Support Area	Division Support Area	Brigade Support Area	Divisional Brigades
Division Support Area	Brigade Support Area	Divisional Brigades	Separate Brigades
Brigade Support Area	Divisional Brigades	Separate Brigades	Separate Battalions
Divisional Brigades	Separate Brigades	Separate Battalions	
Separate Brigades	Separate Battalions		
Separate Battalions			

Table 1. Logistics Node Capability Matrix.

Throughout this study, only theater, intermediate, and terminal supply points are considered. The special cases of railhead, roadhead, and air base supply points are suggested for future research. Proposals are made concerning how to handle these aspects of the logistics structure in the section covering extensions of the basic model.

C. REPRESENTATION OF UNITS

1. Review of the JWAEP Architecture

Combat units in the JWAEP model are described by their unit class data. The unit class data define different sets of objects in the model that share common characteristics. Examples of this are multiple instances of an armor battalion. Each armor battalion of a distinct unit class type has the same initial characteristics within a pre-established degree of variance, such as number of personnel, number of tanks, etc. In military terms, this is called the unit's Table of Organization and Equipment (TO&E). In the JWAEP model the different categories of units are defined in the *class.dat* file.

The type of equipment that may be included in each unit class type is defined in the file *atcal.type.eq*. This is one of the ATCAL files taken from the CEM VII model, with the addition of some fields to support the JWAEP model. [Ref. 4] This file defines all the different equipment and weapon types that may be included in a JWAEP scenario. An example of how equipment types are defined is illustrated in Figure 2.

```

1100 "M1A1"
SIDE . .CLASS . .CATEGORY . .TGT.TYPE . .STONS . .AD.SITE.TYPE . .IMPORTANCE
1      1      1      10001      60.0      0      .80
PALLETS . .SIZECAT . .LAPE%LOSS . .DROP%LOSS . .PP.EQ.CAT
2      3      10      40      10001
WEAPONS . .ID . . .QTY
      1101  1
      1102  1
END.WEAPONS

```

Figure 2. Equipment Type Definition

There are 123 different equipment types defined in the *atcal.type.eq* file. In each case, the first four digit number is the system identification number which is followed by the system name. The other identifiers of interest are the SIDE, which is either 1 or 2, identifying the system as either blue or red equipment; STONS, which is a rough estimate of the single system weight in short tons; TGT.TYPE / PP.EQ.CAT, which identifies the system in broad terms as one of eleven target and post processor equipment types; and finally the WEAPONS ID and QTY, identifying the different major weapon systems by four digit identifier and quantity that the system carries organically.

The type of weapons available to the scenario are also defined in the *atcal.type.eq* file. In this case weapons are defined by their four digit identification number, the name of the system to which the weapon is organic, the side to which the system belongs, and the weight of a single round of ammunition that the weapon fires. Figure 3 illustrates how this portion of the *atcal.type.eq* file appears.

```

      ID . . . NAME . . . . . SIDE . .LBS/ROUND
1101  "M1A1"      1      62.63
1102  "M1A1"      1      1.22
.
.
.
2101  "T72"      2      62.63
2102  "T72"      2      1.22
.
.
.

```

Figure 3. Type Weapon Definition

The different equipment and weapon types are further embedded into units in the JWAEP model. Units are defined in the scenario data files which are specific to the user scenario. The current scenario in use for the development and testing of the JWAEP

model is a Major Regional Contingency involving the invasion of South Korea from the north. The current file *unit.data* defines eleven unit groups, six U.S. and five non-U.S. These unit groups include: Armor Brigade, Mechanized Infantry Brigade, Light Infantry Brigade, Infantry Division, and Artillery Battalion for both sides. Also, there is a Ranger Special Operations Force for the U.S. side. The unit groups are further classified to define the equipment types and number of systems organic to a unit type. Two examples of unit type definitions are included in Figure 4.

1005 "Inf Bde, Mech Div"				
SIDE	..CLASS	..FUNCTION	..MAX.SUPPORT	..RANGE...GROUP
1	1002	1	50	1002
EQUIPMENT				
IDQTYSTDDEV	
1110	104	10		(M1 Tanks)
1200	54	10		(M2 IFVs)
1210	12	2		(ITVs)
1230	18	4		(FST-Vs)
1275	7	1		(NonUS IFV-25MM)
1520	24	5		(155 mm Howitzer)
1600	20	4		(Stinger)
1620	18	2		(4.2 in. Mortar)
1800	1784	200		(Blue Troops, personnel)
END.EQUIPMENT				
1001 "Ranger Reg"				
SIDE	..CLASS	..FUNCTION	..MAX.SUPPORT	..RANGE...GROUP
1	1002	1	50	1003
EQUIPMENT				
IDQTYSTDDEV	
1610	32	5		(Dragon Anti-Tank weapon)
1630	70	5		(81 mm Mortar)
1640	32	4		(60 mm Mortar)
1800	417	50		(Blue Troops, personnel)
END.EQUIPMENT				

Figure 4. Unit Type Definitions

In the definitions for the units above, the type unit is defined by a four digit number, 1005 and 1001 for the units, respectively. This specifies that all units with the same four digit type identifier are the same. Furthermore, this definition specifies the maximum support range for this type unit, MAX.SUPPORT.RANGE. This is the maximum range that this type unit is doctrinally separated from its direct support logistical

unit.² Also included for each type unit is the quantity and type of equipment organic to the unit, along with a parameter of the standard deviation for the quantity, thus allowing for variability in the amount of equipment in each instance of the unit type. A parenthetical description of the equipment types is included here for the reader's information.

The last piece of information in the JWAEP model that ties all of the previous definitions together and is essential for a logistical model is the specification of unit instances included in the model. These definitions are also included in the *coa.data* scenario file. Each definition includes the unit's five digit identification number, unit name, side, type unit, and supply system descriptor, **SSD**. Use of the supply system descriptor is described in Chapter IV. Examples of unit instance definitions are included in Figure 5.

10501	"Inf Bde, 2 Mx Div"
SIDE ..TYPE ... SSD	
1	1005 0
10502	"Inf Bde, 2 Mx Div"
SIDE ..TYPE ... SSD	
1	1005 0
10503	"ROK Inf Bde, 1 Mech Div"
SIDE ..TYPE ... SSD	
1	1015 0

Figure 5. Unit Instance Definition.

2. Basic Load Databases

Two databases must be established, one to hold the predetermined basic load for each weapon system included in the model, and a second to hold the scenario data for each unit. The scenario database contains information for the quantity of supplies currently in the unit, the quantity of supplies necessary to fill a basic load for the unit, and what percentage of basic load is available to the unit currently. This database is where the consumed supplies are decremented and arriving supplies are incremented to the unit's on-

²It is important to note that not all of the data indicated for MAX.SUPPORT.RANGE may be correct according to current U.S. Army doctrine, but they are provided as an example.

hand supplies. The structure of the basic load database is included in Figure 6 and will be called the *basicload.data* file.

ID	NAME	SIDE . . .	LBS/ROUND	BASICLOAD	LBS/BASICLOAD
1101	"M1A1"	1	62.63	50	3131
1102	"M1A1"	1	1.22	2000	2440
.
2101	"T72"	2	62.63	50	3131
2102	"T72"	2	1.22	2000	2440
.
.

Figure 6. Basic Load by Type Weapon Definition

This database is similar to the *atcal.type.equip* file described above, with the addition of two placeholders. The first is for BASICLOAD, which holds the quantity of rounds that make up the basic load for a type weapon system. The second, LBS/BASICLOAD, is the total weight for this quantity of rounds in pounds.

The second database for the scenario data is illustrated in Figure 7.

UNIT.ID	SIDE	EQUIP.ID	WPN.ID	MAX.CAP	ON.HAND	STONS/ON.HAND
10501	1	1110	1101	104	100	156.55
		1110	1102	104	100	122.00
		1200	1201	54	52	29.02
		1200	1202	54	52	96.33
		1210	1211	12	8	4.47
		1210	1212	12	8	4.00
		1230	1231	18	15	0.01
		1230	1232	18	15	0.00
		1275	1276	7	6	3.35
		1275	1277	7	6	11.12
		1520	1521	24	22	44.33
		1520	1522	24	22	3.41
		1600	1601	20	19	4.91
		1600	1602	20	19	0.06
		1620	1621	18	18	20.62
		1620	1622	18	18	0.01
		1800	1801	1784	1526	13.74
		1800	1802	1784	1526	0.76

Figure 7. Scenario Database Definition

This database holds the identification number of the unit, the weapon type identification numbers of each weapon included in the unit, the capacitated and current on-

hand quantities of each type weapon system in the unit, and the weight of ammunition on-hand for the unit.

3. Terminal Supply Points (BSAs)

The terminal supply point is the lowest support level to be represented in JWAEP. With respect to current U.S. doctrine for ground forces, the terminal supply point represents a Brigade Support Area (BSA). There is one BSA established for every divisional or separate brigade located in theater. For divisional brigades, the BSA is normally composed of a Forward Support Battalion (FSB) from the Division Support Command (DISCOM), which is placed in direct support to the divisional brigade. Additionally, the battalion field trains from each combat battalion assigned to the brigade are located at the BSA. BSAs for separate brigades have roughly the same structure, but are considered an organic support battalion to the brigade. The structures of terminal supply points for non-U.S. and enemy forces may take roughly the same form as the U.S. BSA. The level of detail applied to defining these structures remains for future research. For the JWAEP, divisional and separate brigades will have the same composition of support units. The BSA structures for mechanized and light brigades are significantly different in their size and capabilities.

a. Identification

Two separate BSA types need to be defined for the JWAEP model; those in support of mechanized brigades and those in support of light brigades. The logistical unit type may be defined in the scenario *unit.data* file similar to combat units. The unit definitions are illustrated in Figure 8.

1101 "BSA for Mechanized or Armor BDE"						
SIDE	..CLASS	..FUNCTION	..MAX.SPT	..RANGE	..MAX.SPT.AVAIL	..GROUP
1	1101	3	50		1.66	1101
1102 "BSA for Light Infantry BDE"						
SIDE	..CLASS	..FUNCTION	..MAX.SPT	..RANGE	..MAX.SPT.AVAIL	..GROUP
1	1102	3	25		1.33	1102

Figure 8. BSA Type Definitions.

The MAX.SPT.AVAIL parameter is added to the BSA type definition to hold the logistical capacity or capability for the BSA type. Since the BSA may support a

limited number of customers in addition to its assigned combat brigade, this limiting identifier is necessary. In each case for the BSA definitions, it is assumed that the BSA has the capability to support the combat brigade consisting of a combination of three infantry or armor battalions along with its associated slice units — engineers, ADA, direct support artillery, etc. This is called the "base force." The size of the "base force" for each side of the simulation is defined by the user. In addition, the BSAs are allowed to support an additional percentage of its base force. The limiting parameter for the "BSA for Mechanized or Armor BDE" is 1.66. It is allowed to support its "base force," a pre-defined standard heavy brigade, plus 66% of its "base force," or roughly two additional combat battalions along with associated slice units. The limiting parameter for the "BSA for Light Infantry BDE" is 1.33. Therefore, it is allowed to support its "base force," a pre-defined standard light brigade, plus 33% of its "base force," or roughly one additional combat battalion along with its associated slice units.

The MAX.SUPPORT.RANGE here denotes the maximum range from which the BSA is permitted to support its customers. If one of its customers moves outside this range, support to this unit is degraded until the BSA moves to a closer position in proximity to this customer. The calculations for this degradation parameter are explained in a later section.

As with the combat units, BSA instances must also be assigned an identification number and unit name. This information should be maintained in the *unit.data* scenario file along with the combat unit data of the same type. Figure 9 illustrates the BSA instance definitions.

11501	"BSA Inf Bde, 2 Mx Div"		
SIDE	..TYPELATLONG
1	1101	23.6	10.0
11502	"BSA Inf Bde, 2 Mx Div"		
SIDE	..TYPELATLONG
1	1101	41.5	67.9
11503	"BSA ROK Inf Bde, 1 Mech Div"		
SIDE	..TYPELATLONG
1	1111	17.3	33.2

Figure 9. BSA Instance Definition.

The instance definition contains a five digit identification number, a unit name, the side which the BSA supports, the four digit type identifier for the type BSA described, and the ground truth position of the unit.

b. Equipment and Support Capacity

For the purposes of this research, the descriptions, quantities and capacities of the type equipment included in the logistical units modeled are not the same as those organic to actual logistical units. The only purpose here is to describe how the logistical structure works. The actual descriptions and quantities may be revised at a future date.

Similar to the *atcal.type.eq* file, a *log.type.eq* file must be included that defines all the type equipment included in the logistical units. For the purposes of the initial model, this will only include ground conveyance type vehicles such as trucks. Future versions of the model may incorporate aircraft, rail equipment, and sea going vessels such as ships, barges, etc. An example of the information contained in the *log.type.eq* file is included in Figure 10.

ID	NAME	SIDE	CAP.LBS	CAP.CUBIC	CAP.GAL
5101	"2.5 Ton Truck"	1	5000	1400	0
5102	"5 Ton Truck"	1	10000	1920	0
5103	"HEMMT Trailer"	1	20000	9000	0
5104	"HEMMT Fueler"	1	0	0	20000
.
6101	"2.5 Ton Truck"	2	5000	1400	0
6102	"5 Ton Truck"	2	10000	1920	0
6103	"Hvy Duty Trailer"	2	20000	9000	0
6104	"Hvy Duty Fueler"	2	0	0	20000
.
.

Figure 10. Logistics Type Equipment Definition

In the case of logistics equipment the capacities for each truck are given in pounds of dry weight, cubic feet and gallons of liquid supplies such as fuel or water. A vehicle which is not specifically designed to carry liquid supplies has zero capacity to do so, while a liquid carrying vehicle cannot carry dry cargo.

As with the definitions for combat units the BSAs also must have unit definitions that include the types and quantities of equipment. These, and all logistics unit definitions, may be inserted into the *unit.data* file with the combat unit definitions. The

listing of equipment organic to each type organization is included directly below the logistics unit type definitions described in Figure 4. Complete definitions of the unit types and their organic equipment are illustrated in Figures 11 and 12. The number of personnel organic to the unit are also included in the definitions. The quantities used for these data elements (U.S. Army units) are found in U.S. Army Field Manual 101-10-1/1. [Ref. 13]

1101 "BSA for Mechanized or Armor BDE"						
SIDE	CLASS	FUNCTION	MAX.SPT.RANGE	MAX.SPT.AVAIL	GROUP	
1	1101	1	50	1.66	1101	
EQUIPMENT						
ID	QTY	STD	DEV			
5201	30	4		(2.5 Ton Trucks)		
5202	25	4		(5 Ton Trucks)		
5203	10	2		(HEMMT Trailer)		
5204	12	2		(HEMMT Fueler)		
.		
.		
1800	900	100		(Blue Troops, personnel)		
END.EQUIPMENT						

Figure 11. Mechanized BSA Type and Equipment Definitions.

1102 "BSA for Light Infantry BDE"						
SIDE	CLASS	FUNCTION	MAX.SPT.RANGE	MAX.SPT.AVAIL	GROUP	
1	1102	1	25	1.33	1102	
EQUIPMENT						
ID	QTY	STD	DEV			
5201	20	4		(2.5 Ton Trucks)		
5202	10	2		(5 Ton Trucks)		
5203	5	1		(HEMMT Trailer)		
5204	4	1		(HEMMT Fueler)		
.		
.		
1800	600	75		(Blue Troops, personnel)		
END.EQUIPMENT						

Figure 12. Light BSA Type and Equipment Definitions.

c. Assigning Customers

The initial assignment of customers to BSAs is simple due to the fact that for every divisional and separate brigade that enters the theater of operations, a BSA, either mechanized or light, also enters the theater. The next step in assigning customers is to assign any separate battalion sized units that need support from a BSA. BSA assignments for separate battalions in the model will be done initially by the user putting

the assignment into the *logistics.customer.data* file, which must be established. An example of the information to be kept in the *logistics.customer.data* file is depicted in Figure 13.

LOG UNIT ID #	SIDE	CUSTOMER ID #s
11501	1	10501
11502	1	10502
11503	1	10503 10508

Figure 13. BSA Instance Definitions.

The *logistics.customer.data* file contains the logistics unit identification numbers of all the logistics units in the scenario, along with the side that they support and the unit identification numbers of the combat units assigned to each logistics unit as customers.

d. Determining Stockage Levels

Stockage levels for each BSA in the model are a function of the units assigned to them as customers and the number of basic loads of ammunition, or other supply classes, that the BSAs are required to keep on-hand. Before these levels may be calculated an identifier must first be added to the *atcal.type.eq* file to keep the parameter for the basic load for each type weapon used in the model. The basic load is the initial amount of each type ammunition or rounds that each weapon type should have. It is also the doctrinal amount of ammunition that units should try to maintain with each weapon.

Stockage levels are managed by the weight of ammunition stockpiled in the BSA. One of the assumptions of this methodology is that the stockpile is composed of the correct mix of ammunition for the unit supported. Once the basic loads for each weapon type are established in the model, the stockage levels for each BSA may be determined by first computing w_u , the weight of the total basic load ammunition in short tons, needed in each unit according to equation 1.

$$\frac{\sum_a w_{as} (bl_{as}) S}{2000} = w_u \tag{1}$$

where

w_{as} = the weight, in pounds, of each round of ammunition by type weapon system s

bl_{as} = the basic load of ammunition type a per system type s

S = the total number of type s systems present in the unit.

This is a dynamic equation that varies according to the number of personnel and weapon systems currently active in the unit. The summation is over all ammunition types a in the unit. The sum of the w_u 's, over all units supported by the BSA, is calculated to find the total weight of one basic load of all ammunition types stocked by the BSA. Similar calculations may be made to determine a basic load for POL stocks within a unit by type fuel and gallonage.

For the purpose of this research, the goal of the BSA is to maintain a minimum of two complete basic loads of ammunition and POL stocks. The first basic load is attributed to the combat units supported by the BSA, representing the ammunition located with each weapon system. The second basic load represents the total amount of ammunition that can be physically stockpiled at the BSA. Mission requirements may compel support units to acquire more than two basic loads on-hand until a mission order is changed.

The BSA cannot transport all of the ammunition in its stockpiles when its stockpiles are above the threshold that it can transport using all of its available trucks, e.g.,

$$stockpiles_c > \sum_{k=1}^n \sum_{l=1}^m truckcapacity_{kl} \quad (2)$$

where,

k = the types of different trucks in the unit,

l = the number of trucks k in the unit,

c = the supply type (ammunition, fuel, other).

In a case such as this, the supply unit must destroy or transport the additional stocks to its customers before it begins to relocate. The algorithm for this process for the ammunition supply class follows:

Calculate amount of supplies to transport
 $NextResupply = \text{Sum of the amounts of supplies scheduled for delivery to all customer units}$
 $SuppliesToTransport = \Sigma (OnHand - NextResupply), \forall \text{ customers}$
 Calculate amount of transport capacity available
 $TransportCapacity = (\text{Truck Capacity} * \# \text{ of trucks available}), \forall \text{ truck types}$
 Are $SuppliesToTransport > TransportCapacity$?
 YES;
 Are there customers that can be resupplied within 24 hours?
 YES;
 Determine amount of supplies that each customer can accept
 $AcceptAmount = \Sigma (\text{MaxCapacity} - \text{OnHand} - \text{Nextresupply}), \forall \text{ customers capable of resupply within 24 hours}$
 $Overage = SuppliesToTransport - TransportCapacity - AcceptAmount$
 NO;
 $Overage = SuppliesToTransport - TransportCapacity$
 NO;
 There is no problem transporting all stockpiles
 Destroy Overage
 Return.

e. Determining Relocation Methodology

When customer units relocate, either due to new orders or maneuver, the BSAs may also need to relocate. In this manner the BSAs are tied to the combat units that they are supporting. However, due to the cumbersome task of packing and unpacking equipment and the delay associated with these tasks, the BSAs should be restricted to only one move in a twenty-four hour period.

Since it is not possible to guarantee that a logistics unit may always be located at a physical node of the network, logistics units are considered to always be located at some point along an arc (transit node) of the network. The arc position of a support unit may be determined by comparing its (LAT, LONG) position to the JWAEP scenario arc-node database. When the BSA has moved to a new position it has a velocity of zero at that position on the arc. The methodology to determine when a BSA will move is based upon its distance from its customer units. The BSA will move twenty-four hours after it determines either that the distance to half, or more, of its customers is greater than or equal to three quarters of its MAX.SPT.RANGE, or that the distance to one of its customers exceeds its MAX.SPT.RANGE, or that the distance to one or more of its customer units has become less than one quarter of its MAX.SPT.RANGE. The twenty-

four hour period is allowed for sending out an advance party and boosting customer supply levels prior to the move, since supply trains are not available to customers during the movement of the BSA. Additionally, the distances from each BSA to each of its customer units are calculated at least once every twenty-four hours.

The next position for the BSA is calculated by determining a point on an arc equal to one quarter of the BSA's MAX.SPT.RANGE from the customer combat unit, with some variance. In the case where there is more than one customer unit, a point is found which is equidistant from all customer units, within a pre-determined tolerance. For the purpose of this research, if there is more than one available arc on which to position, the arc chosen for the BSA location will be the position closest to the BSA's direct support unit. An example algorithm for the relocation of the BSA is given below.

Calculate distance(s) between BSA and customer(s)
*Is distance $\geq .75 * MAX.SPT.RANGE$ for more than $1/2 * \#$ of customers?*
or
Is distance to one customer $> MAX.SPT.RANGE$?
or
*Is distance $\leq .25 * MAX.SPT.RANGE$ for one or more customers?*
YES;
StartMoveTime = Simtime + 24.00 hours
Find the list of available arcs (routes) leading to the
customer units, label each arc 1 to j
Calculate a potential new position on each available arc =
*.25 * MAX.SPT.RANGE*
Label each new position P_{ij} , for each position i on arc j
Calculate distances from each position P_{ij} to each customer using
a shortest path algorithm, such as Dijkstra's algorithm,
modified to account for units positioned on transit nodes
not necessarily physical nodes
Calculate the mean and the variance for the distances to all
customers, from each position P_{ij}
Calculate distances from DSA (parent unit) to each position P_{ij}
Choose the position P_{ij} that minimizes the distance to the DSA
and minimizes the mean and variance of the distance to its
*customers, but is still $> .25 * MAX.SPT.RANGE$*
If no position meets the criteria
Choose the position that minimizes the mean and variance
of the distances to its customers
If there is a tie
Choose position which has least restrictive terrain
else
Choose the position with the smallest arc label.

Calculate Travel time to next position P_{ij} .
NO;
RETURN.

During movement all elements in the BSA move together and movement speed is restricted to the speed of its slowest moving independent element along the route of march. For targeting purposes the unit is considered to be in convoy with an associated separation distance between vehicles based upon speed, threat, terrain, and visibility.

4. Intermediate Supply Points (DSAs and CSAs)

As with the terminal supply points, the definitions for intermediate supply points must also be described. For the purposes of the JWAEP model intermediate supply points identify those logistics nodes which are not established for the sole purpose of providing direct support to combat units, nor are they established to accept theater level amounts of supplies for redistribution. Both of these objectives are the primary domain of the terminal and depot supply points, respectively. However, to support the dynamics of the logistics process, intermediate supply nodes should be capable of accomplishing both of the previously described tasks.

The primary purpose of intermediate supply nodes in the JWAEP model is to act as distributor nodes to allow for the movement of supplies from depot nodes to the combat units without direct interaction between these two unit types. Both Division Support Areas (DSAs) and Corps Support Areas (CSAs) fall into this category of supply nodes.

a. Identification

As with the BSA definitions, two separate DSA types must be defined, one for mechanized divisions and one for light divisions. Only one type definition is necessary for the CSA; however, the user will input the number and type of assets in each CSA depending upon the scenario. The logistical unit type will be defined in the scenario *unit.data* file similar to BSA units. The unit definitions are illustrated in Figure 14.

1201 "DSA for Mechanized or Armor Division"					
SIDE	CLASS	FUNCTION	MAX.SPT.RANGE	MAX.SPT.AVAIL	GROUP
1	1201	4	125	5.00	1201
1202 "DSA for Light Infantry Division"					
SIDE	CLASS	FUNCTION	MAX.SPT.RANGE	MAX.SPT.AVAIL	GROUP
1	1202	4	75	5.00	1202
1300 "CSA for Corps"					
SIDE	CLASS	FUNCTION	MAX.SPT.RANGE	MAX.SPT.AVAIL	GROUP
1	1300	5	175	15.00	1300

Figure 14. DSA and CSA Type Definitions.

The FUNCTION parameter distinguishes the DSA from the CSA supply units. In each DSA instance, FUNCTION is four (4) and for CSAs it is five (5). MAX.SPT.RANGE and MAX.SPT.AVAIL are greater in both cases than for the BSA unit to allow for the enhanced capabilities of the intermediate supply units. Also, the CSA nodes have greater capabilities than the DSA nodes. In each case, MAX.SPT.AVAIL is given in terms of the maximum amount of brigade sized "base force" units that the supply node type can support. The CSA type uses the mechanized "base force" for its calculations.

b. Equipment and Support Capacity

The descriptions of equipment and support capacity parameters for intermediate nodes are similar to those of the terminal supply nodes. The only real differences among these units are the amount and types of equipment included in them. The general descriptive parameters function the same as for the terminal supply nodes.

c. Assigning Customers

Customer assignment to intermediate supply nodes is similar to assignment for terminal nodes. For the purposes of this research, dynamic assignment of customers to supply nodes during simulation play will not be done. Assignment of customers to the DSAs and CSAs is done by the user. Assignments of customers are stored in the *logistics.customer.data* file.

d. Determining Stockage Levels

The stockage levels for DSAs and CSAs are computed using the same methodology as for the BSA nodes. The intermediate supply nodes must keep stockage levels capable of supplying all of the units for which they are in direct support. In most

cases these units will include other supply nodes, so the magnitude of the stockage levels for DSAs and CSAs will be from three to twelve times larger than that of a BSA. Each CSA and DSA will also try to maintain two complete basic loads for all ammunition types, and have the same restrictions on movement of overstocked supplies. The rules for supply units supporting more than one customer are described in a later section.

e. Relocation Methodology

The intermediate supply nodes use the same relocation algorithm outlined for the BSA. The primary difference for the intermediate supply nodes is that movement time from one location to the next will be between forty-eight and seventy-two hours, rather than twenty-four hours.

5. Theater Supply Points

Depot supply points and ports are those supply nodes that act as theater supply points. They are the primary points of entry for all supplies moving into theater. In the JWAEP model supplies will be delivered to the theater supply points from a source node. There is no limit to the amount of supplies that may be stockpiled at the depot supply points; however, this type of supply node may not be moved. Theater supply points are normally placed at sea ports or air ports. After the simulation begins, new theater supply points may be established only at sea and air ports if they were scripted into the simulation before it began.

a. Identification

Theater supply nodes use the same identification structure as the other types of supply nodes. To provide for future enhancement of the model, three types of depot and port supply nodes are provided. The definitions for these types are illustrated in Figure 15.

1400 "Theater Supply Node - Sea Port"					
SIDE	..CLASS	..FUNCTION	..MAX.SPT.RANGE	...MAX.SPT.AVAIL	...GROUP
1	1400	4	300	30.00	1400
1401 " Theater Supply Node - Air Port "					
SIDE	..CLASS	..FUNCTION	..MAX.SPT.RANGE	...MAX.SPT.AVAIL	...GROUP
1	1401	4	1000	21.00	1401
1402 " Theater Supply Node - Ground "					
SIDE	..CLASS	..FUNCTION	..MAX.SPT.RANGE	...MAX.SPT.AVAIL	...GROUP
1	1402	4	500	30.00	1402

Figure 15. Theater Supply Node Definitions

These definitions provide for theater level supply nodes at sea ports, air ports, and ground bases, such as railheads or roadheads. Here again, the parameter MAX.SPT.AVAIL defines the maximum number of "base force" mechanized brigade sized units that each type supply node can support.

b. Equipment and Support Capacity

Much like CSA nodes, theater supply nodes do not have a standard configuration. The equipment located at these supply nodes is determined by the user and established in the initialization of the simulation. An increase or decrease in the amount of equipment located at a depot or port supply node, other than a decrease due to attrition from enemy fire, must be scripted into the simulation.

The descriptions of equipment and support capacity parameters for theater supply nodes have the same structure as that of the terminal and intermediate supply nodes. Again, the only real differences among these units are the amount and types of equipment included in them. The general descriptive parameters function the same as for the other types of supply nodes.

A special restriction on a sea port theater supply point is the number and size restriction of ships capable of being docked at the port. Docks of a port are to be defined as special equipment types in the *log.type.eq* file. The essential information included for docks in this file is the size ship capacity of the dock described in tons of water displaced, DISP. Figure 16 illustrates an equipment definition for docks.

ID	NAME	SIDE	DISP
5401	"Dock, 10K tons"	1	10
5402	"Dock, 25K tons "	1	25
5403	"Dock, 40K tons "	1	40
5404	"Dock, 100K tons "	1	100
.	.	.	.
.	.	.	.
6401	"Dock, 10K tons"	2	10
6402	"Dock, 25K tons "	2	25
6403	"Dock, 40K tons "	2	40
6404	"Dock, 100K tons "	2	100
.	.	.	.
.	.	.	.

Figure 16. Equipment Definition for Docks.

c. Determining Stockage Levels

Stockage levels for theater supply nodes are computed using the same methodology as for the terminal and intermediate nodes. Theater supply nodes must keep stockage levels capable of supplying all of the units for which they are in direct support. In most cases these units will include intermediate supply nodes, so the magnitude of the stockage levels for depots and ports will be from three to six times larger than that of a DSA or CSA. The goal of each theater supply node is to maintain three complete basic loads for all ammunition types, for all the units that they support. Unlike the other supply node types, theater nodes do not move and there are no restrictions placed on the amount of supplies overstocked in theater supply nodes.

d. Assigning Customers

Customer assignment to theater supply nodes is the same as assignment for intermediate nodes. Again, dynamic assignment of customers to theater supply nodes during simulation play is not represented here. Assignment of customers to the depots and ports is done by the user. Assignments of customers are stored in the *logistics.customer.data* file.

D. MATERIAL HANDLING EQUIPMENT (MHE)

An additional requirement for supply units at all levels is the need for material handling equipment (MHE) such as forklifts, cranes, etc., and personnel to operate these

pieces of equipment. The equipment types are defined along with all other logistics equipment in the *log.type.eq* file.

The terminal, intermediate, and theater supply points use the MHE information to determine the lengths of time necessary to load and unload large amounts of supplies. This information determines the amount of supplies available for transfer at a given time. If supplies are being unloaded from a truck, ship, or aircraft, they are not available for transfer to a customer. Additionally, if MHE personnel or systems are destroyed, or otherwise unavailable, the rate of transfer of supplies into the supply point's stockpiles is reduced. This places an additional constraint on the logistics units to maintain appropriate levels of MHE personnel and equipment.

An equation may be developed for each MHE system type to describe the rate at which personnel, using that equipment type, could be expected to unload, or load, supplies from a specific type conveyance vehicle, given adequate personnel are present. To determine the number of personnel available to operate the material handling equipment, the user must define the proportion of personnel, present in the unit, that the support unit commander will designate as MHE personnel. This proportion determines the number of MHE personnel available at any time during the simulation. When support troops are operating MHE they are unavailable to provide other functions in the model, such as driving trucks. For example, there are 100 troops present at the unit and the user has designated that 10% will be used for MHE, thus providing 10 personnel. There are seven forklifts at the unit along with the 10 personnel to operate them. A forklift takes two personnel to operate it, so only five forklifts can be used at the unit, and two remain idle. A single forklift with two operators can unload 20 STONS per hour, and there are 1000 STONS of supplies to unload. The unload time for this example is given in equation (3).

$$\text{UnloadTime} = 1000 \text{ stons} / (5 \text{ forklifts} \cdot 20 \text{ stons / hour / forklift}) = 10 \text{ hours} \quad (3)$$

However, if the unit was operating all seven forklifts it could do the same job in 7.14 hours. The units effectiveness is reduced by its inability to operate all of its equipment.

Similar equations may be developed for other MHE types; however, it is recommended that these be kept to a minimum.

E. CONSUMPTION OF SUPPLIES

Supply requirements are generated by consumption or losses in both the combat and logistics units. For the purposes of this research, consumption is defined at two levels: baseline consumption and emergency consumption. Losses may occur due to attrition of supplies and equipment, or from other incidents such as accidents, spoilage, fuel spills, etc.

Baseline consumption is the routine consumption rate at which units exhaust supplies on an average daily basis. This consumption rate accounts for supplies consumed through training and levels of combat that are not so intense as to deplete the maneuver units' immediate stocks. A baseline average daily consumption rate is input by the user in the logistics model. The baseline consumption rate also takes into account normal supply losses not due to attrition.

Emergency consumption occurs on a non-routine basis when units are involved in intense combat and need immediate and / or continuous resupply. Emergency consumption is conditioned primarily on the ability of the ATCAL / COSAGE model to provide data that can dynamically drive the consumption rates of the units in combat.

Supply losses due to attrition are a subset of emergency consumption. These losses are calculated. The calculations used for truck losses at a supply point due to aerial attack are based upon the Binomial probability that a single aircraft kills k trucks at the supply point ($P[\text{one aircraft kills } TL_m \text{ trucks}] \sim \text{Binomial} \{ NumTrucks_m, p_k \}$), where,

TL_m = Trucks lost of type i at supply point n ;

p_k = probability of a truck being destroyed by an aircraft;

$NumTrucks_m$ = total number of trucks of type i at supply point n ;

$NumAC_n$ = total number of aircraft in the attack on supply point n .

The probability that a single truck h survives an attack by $NumAC_n$ aircraft is found using equation (4), where the resulting probability is p_h .

$$p_h = (1 - p_k)^{NumAC_n} \quad (4)$$

The probability that a truck h is destroyed by the attack of $NumAC_n$ aircraft is therefore $(1 - p_h) = q_h$. The total number of trucks j destroyed by the aerial attack is therefore distributed as Binomial $\{ NumTrucks_{in}, q_h \}$, where $j = 0, 1, 2, \dots, NumTrucks_{in}$. These calculations must be done for both the organic asset trucks and for the non-organic trucks at the supply point during the attack.

Similar calculations are done to find the number of trucks destroyed on a transit arc due to aerial attack, where,

TL_{ia} = Trucks lost of type i on transit arc a ;

p_k = probability of a truck being destroyed by an aircraft;

$NumTrucks_{ia}$ = total number of trucks of type i on transit arc a ;

$NumAC_a$ = total number of aircraft in the attack on transit arc a .

The probability that a single truck h survives an attack by $NumAC_a$ aircraft is found using equation (5), where the resulting probability is p_h .

$$p_h = (1 - p_k)^{NumAC_a} \quad (5)$$

The probability that a truck h is destroyed by the attack of $NumAC_a$ aircraft is therefore $(1 - p_h) = q_h$. The total number of trucks TL_{ia} destroyed by the aerial attack is again distributed as Binomial $\{ NumTrucks_{ia}, q_h \}$, where $TL_{ia} = 0, 1, 2, \dots, NumTrucks_{ia}$.

The amount of supplies destroyed at a supply point is found using a normal approximation. In this situation, the calculations yield the number of short tons of supplies destroyed by aerial attack, where,

SL_{bn} = Short tons of supplies lost of type b at supply point n ;

SL_b = Short tons of supplies lost of type b from a single aircraft;

$STSpy_n$ = total short tons of supplies lost at the supply point n ;

$NumAC_n$ = total number of aircraft in the attack on supply point n .

The amount of short tons of supplies, SL_{bn} , that $NumAC_n$ aircraft destroy is distributed as Normal $\{ (NumAC_n)(SL_b), (NumAC_n)(\sigma_a^2) \}$, where σ_a^2 is the variance on the distribution of supplies lost currently in the JWAEF model. The resulting estimate for the total supplies lost in the attack over all supply types b is found using equation (6).

$$STSpyn = \sum_b SL_{bn} \quad (6)$$

For the supplies being transported by trucks along targeted arcs, the supply losses are calculated as the product of the trucks lost on the arc and the capacity of truck type i , as in equation (7).

$$SL_{ja} = TL_{ia} * TCap_i \quad \forall \text{ supply types } j \text{ and truck types } i \text{ along arc } a, \quad (7)$$

where,

SL_{ja} = Supplies lost of type j at transit arc a ,

TL_{ia} = the number of trucks of type i destroyed on transit arc a ,

$TCap_i$ = the capacity of truck type i .

Additional considerations may be made to include short tons of supplies destroyed while transported on trucks that are not destroyed; however, this is not represented here.

F. TRANSPORTATION AND RESUPPLY

1. Into Theater

Supplies coming into theater are automatically generated by a source node to fill the needs of the theater supply points. This structure allows for potential enhancement by placing constraints upon the source node. Turnaround time, the time between when supplies are requested and when they are delivered to the theater supply nodes, is dependent upon the type of theater supply point making the request. The times for sea and air theater supply points are determined by the user. These times should reflect reasonable transport times for supplies coming from the nearest friendly sea or air port capable of providing the supplies to the theater. For example, the time to transport equipment by sea from San Francisco to South Korea could be seven days. However, if the supplies are transported by air, a reasonable time is twenty-four hours. Transportation times of supplies going to a ground based theater supply node are calculated using the equations for road travel already included in the JWAEP model.

2. Within Theater

Convoy and truck movement is not explicitly represented in the logistics model for JWAEP. However, there is certain information that must be maintained in order to lend the model more realism. This information is important in allowing the model to deal with movement of supplies from and to supply points and along arcs, all of which may be interdicted by aerial attacks. Information must be kept concerning the number of trucks and amount of supplies located at a supply point, or along an arc, when the supply point, or the respective arc, is hit by an aerial attack.

a. Route Designation

Every time a supply node relocates itself to a new position, or one of its customers relocates to a new position, the supply node must re-designate the routes that will be used by its convoys to transport supplies to its customers. Once a new position is determined for a supply node, the shortest route to each of its customers is found and labeled, using a modification of Dijkstra's shortest path algorithm currently used in the JWAEP model. [Ref. 4] For simplification, only one route from the supply node to each of its customers will be used.

b. Target Information

A linked list of all the arcs that constitute each route is maintained for each supply node. Trucks may be in three locations of the network. These locations are at their organic supply node, on a transit arc, or at a customer supply node. The following information must be maintained in order to keep track of the number of trucks that are at these locations:

- The number and type of trucks on a designated route
- The amount of supplies being transported along a route
- The simulation start time, predicted total transport time, and off-load time for each convoy
- A binary list of the number and type of organic trucks either located at the node or in convoy
- A list of the number of non-organic trucks at a supply node.

This information is needed to determine the number and types of trucks and supplies attrited during attacks on either the supply nodes or the transit nodes (arcs).

Additionally, five truck types are defined for the JWAEP model, listed in Table 2.

Truck Type	Truck Description	Truck Capacity
Small Truck Type	2.5 Ton Cargo Truck	5,000 lbs.
Medium Truck Type	5.0 Ton Cargo Truck	10,000 lbs.
Large Truck Type	22.5 Ton Tractor Truck	45,000 lbs.
HET Truck Type	40.0 Ton Heavy Equipment Transport Truck	80,000 lbs
Fuel Truck Type	5,000 Gallon Fuel Truck	5,000 gallons

Table 2. Truck Type Descriptions.

Convoys are notionally on their designated routes for a predetermined amount of time, calculated according to distance, trafficability, and speed of travel. When convoys begin transport along their route, an amount of supplies equivalent to the amount that they are carrying is deducted from the point of origin supply node. If convoys were reduced due to enemy fire, accidents, etc., the supplies they were carrying are deducted from the convoy. When the convoys arrive at their destination, they remain an amount of time determined by MHE availability, simulating off-loading, and then make the return trip. At the end of the destination off-load time the supplies designated as being transported by the convoy are added to the customer supply node stocks. If the customer supply node is targeted while the trucks are delivering resupply, then a separate Monte Carlo draw of the trucks in question is conducted and damage assessed to these trucks. If an arc is targeted and hit while trucks are on it, again a Monte Carlo draw is conducted to assess the number of trucks hit and amount of damage. At no time will convoys be physically represented traveling on arcs, due to the impracticable computational requirements of this approach.

c. Supply Requests

Supply requests are generated daily at every level of the logistical network, under the push system. Each supply node requests supplies for each supply class from its direct support unit in order to bring its stocks back to their requisite levels. Additional

supply requests may be generated if the stocks at a supply node drop below a user defined threshold, or the unit is given new orders and does not have enough supplies on-hand to begin its new mission. This initiates a pull system for the customer. The ability of a support unit to fill a customer's request depends on the availability of the support unit's supply assets, which are the supplies on-hand, trucks available, and MHE being operated at the support unit. Descriptions of the pull and push systems for the model, and the extent to which all supply requests are filled, is provided in Chapter IV.

G. EXTENSIONS OF THE BASIC STRUCTURE

1. Medical and Maintenance Systems

These two systems operate under similar structures that allow for the requisition and delivery of replacement personnel and equipment, respectively. Using the assumption that the ATCAL / COSAGE model delivers dynamic data that will yield the number of soldiers wounded and evacuated to field hospitals, and weapon systems, by type, that may be repaired, the units can request replacement personnel and equipment to bring the unit back to its authorized strength.

a. Medical

For ease of computation, a single personnel source is established that handles personnel from two categories: new and returned to duty. New personnel are generated on an as needed basis in the model, much like the source node generates supplies for theater supply points. Return to duty personnel represent those personnel wounded in combat that are evacuated to a field hospital, are allowed to heal, and are then returned to a unit.

For the purposes of this model, personnel categorized as return to duty are held at the personnel source. A percentage of the personnel categorized as return to duty are released each day, in the simulation, to fill personnel shortages in units. The percentage of personnel released may be at a constant rate determined by the user, or computed based upon the number of personnel being held and the average amount of time for a person held at the personnel source.

b. Maintenance

The maintenance system operates similar to the medical system except that it uses an equipment source that categorizes equipment as new or repaired. The major difference in the maintenance system is that it has the potential to manage equipment by type, since all the equipment types are defined in the model. New equipment is generated as needed. Repaired equipment is considered to be evacuated from the battlefield and, after a period of time, restored to original condition so that it may be reissued to a unit.

The user should be able to adjust the rate at which equipment is repaired and returned and the rate at which new equipment is generated in the model. These rates may be constant or computed based upon the average repair time for a given type of equipment.

2. Rail and Ship Movement

Additional considerations are the representation of railroads and supply ship movement within a naval force. Both of these processes can be modeled in a similar manner. In either case a separate network is defined, either representing a rail network or one allowing travel between ports. Only vehicle types defined as trains and ships may use these networks, respectively. In both networks the transport vehicles (trains and supply tender ships) load supplies at a point within the network (potentially from the source node for the tenders) and deliver their cargo directly to other nodes along their respective networks. In the case of a railroad, these might be rail stations or any supply unit site set up along or near the railroad. For the supply tenders, the other nodes are the operating arcs for the ships that the tenders service.

Targeting and attrition algorithms for each network differ, due particularly to the fact that the rail network can be physically destroyed, while the sea network cannot.

IV. METHODOLOGY FOR MODELING LOGISTICAL CONSTRAINTS ON COURSES OF ACTION

A. GENERAL

In its broadest sense, the logistics structure proposed for the JWAEP model acts as a constraint on the units within the model by placing limits on the amount of supplies that units can consume, request, carry, and receive. The proposed model, even in a rough form, is much more realistic than the current model of infinite supply.

The additional proposals presented in this chapter create a more realistic logistical structure by relating decisions that concern unit resupply and course of action feasibility to the logistical model.

B. LOGISTICS STRENGTH PARAMETERS

Four aggregated strength parameters are proposed to hold the logistic strength characteristics of the individual units. [Ref. 15] These four parameters are:

- Ammunition
- POL
- Surface Transport
- Air Transport

These Logistics Strength Parameters are intended for use in the decision making process of the model as estimates of friendly and enemy logistical strength capabilities. These parameters are the foundation for the second part of this research which allows for estimates of the logistical supportability of courses of action.

1. Mechanized Brigade Basic Load Equivalent (MBLE)

A Mechanized Brigade Basic Load Equivalent (MBLE) is defined as the weight of dry cargo, in short tons, or volume of liquid cargo, in gallons, of a complete basic load for a fully equipped and manned mechanized infantry brigade. This term may be applied to all supply classes where a basic load is already defined, such as ammunition. For other classes of supply, such as POL, a basic load may be defined as the amount of that supply class expected to be consumed by a mechanized infantry brigade over a period of seven

days calculated using the standard usage profile for a mechanized infantry brigade from [Ref. 14]. The standard usage profile is neither mission nor location specific. A separate MBL is defined for each supply class defined in the model. Unless further specified, the term MBL is applied with reference to the ammunition supply class throughout the remainder of this study.

The MBL parameter may be force dependent such that each side or country may be assigned a different MBL size, or force independent such that all units on both sides use the same standard MBL. In either case the MBL is a point of reference from which to base the amount of supplies a unit requires or has available.

2. Ammunition (LAM) and POL (LPO)

The LAM and LPO logistics strength parameters are vector parameters of two elements,

$$(\mathbf{MBLE}_{OH}, \mathbf{MBLE}_{REQ})$$

where,

\mathbf{MBLE}_{OH} = the ground truth value for the number of mechanized brigade basic load equivalents, for ammunition or POL, that are physically on-hand at the unit.

\mathbf{MBLE}_{REQ} = the ground truth value for the number of mechanized brigade basic load equivalents, for ammunition or POL, required to be on-hand to conduct its assigned mission.

The amounts for \mathbf{MBLE}_{REQ} are dependent upon the mission assigned to the unit and may be adjusted by the user. An example of the number of \mathbf{MBLE}_{REQ} for a single BSA supporting a mechanized infantry brigade is included in Table 3.

Mission Order	Ammunition Required	POL Required
1. Attack	3.00 MBLE	2.75 MBLE
2. Defend	3.00 MBLE	2.50 MBLE
3. Movement to Contact	2.75 MBLE	2.50 MBLE
4. Delay	2.50 MBLE	2.50 MBLE
5. Tactical March	2.25 MBLE	2.25 MBLE
6. Administrative March	2.00 MBLE	2.25 MBLE
7. Tactical Assembly Area	2.00 MBLE	2.00 MBLE

Table 3. BSA Mission MBLE Requirements.

In the case of $MBLE_{REQ}$ for a single combat unit, requirements are dynamically based upon the number of personnel and weapon systems currently active and assigned to the unit, (e.g., if a unit only has 75% of its authorized personnel and equipment and is normally required to have 3.00 MBLE for an attack mission, then its requirement is modified to $3.00(0.75) = 2.25 MBLE_{REQ}$).

The calculations for $MBLE_{REQ}$ at each level of support depend upon the required amount of ammunition and POL that the support unit is required to have on-hand to support its customers' assigned missions. The user decides the amount of supplies to be required at the support units based upon the amount required for its customers. For example, if a DSA is supporting three BSAs and each BSA has $MBLE_{REQ} = 2.0$, the user may decide that the DSA should have 0.75 $MBLE_{REQ}$ for each MBLE that its customers are required to maintain. Therefore, the $MBLE_{REQ}$ for the DSA is $0.75(2.0)3 = 4.5$ MBLE.

Some of the advantages of these parameters are:

- They can yield a ratio of supplies on-hand / supplies required which may be used, along with other information, by a decision maker to determine a unit's logistical strength and potential to conduct or continue a mission.
- They carry enough information to compare logistical units at different echelons for targeting decisions.

- Along with information such as a unit's average daily consumption, they can yield estimates for a unit's supplies on-hand in terms of days of supply.

3. Surface Transport (LST) and Air Transport (LSA)

The LST and LSA logistics strength parameters are three parameter vectors,

$$(\mathbf{MBLE}_{\text{AMM}}, \mathbf{MBLE}_{\text{POL}}, \mathbf{TIME})$$

where,

$\mathbf{MBLE}_{\text{AMM}}$ = the ground truth value for the number of mechanized brigade basic load equivalents for ammunition that the unit can transport in a single convoy using all available supply trucks.

$\mathbf{MBLE}_{\text{POL}}$ = the ground truth value for the number of mechanized brigade basic load equivalents for POL that the unit can transport in a single convoy using all available fuel trucks.

\mathbf{TIME} = the amount of time necessary to load and unload the $\mathbf{MBLE}_{\text{AMM}}$ and $\mathbf{MBLE}_{\text{POL}}$ using the unit's available material handling equipment and personnel and to transport these supplies a distance of 100 kilometers, over flat terrain, under administrative march orders. This term applies to the total convoy and is dependent upon whichever of the two, $\mathbf{MBLE}_{\text{AMM}}$ or $\mathbf{MBLE}_{\text{POL}}$, takes the most time.

These parameters can yield the following information for a decision maker under the assumptions of constant loading and unloading times for different classes of supplies:

- The maximum amount of supplies a unit can transport in a single convoy.
- The time needed for a unit to transport a given amount of supplies.
- The effects on transportation time as impacted by constraints due to MHE and personnel.

C. ESTABLISHING UNIT PRIORITIES

All ground units are prioritized by the logistical model in order to make logistical decisions. Units are prioritized starting at the lowest level of unit representation. Priorities for the successive echelons are established based upon those priorities set at the levels below them, with the terminal support level as the lowest and theater support level

as the highest. In all cases, a higher priority value for a unit gives the unit priority over the other customers supported by its direct supplier.

Figure 17 depicts an example of a Direct Support Tree which illustrates the relationships among support units and their customers. A line from a higher to lower support level indicates that the higher echelon support unit is in direct support to the lower level unit (i.e., the lower level unit is a customer of the higher level unit). Within support levels, as in the intermediate and terminal support levels, units on the left end of the support line are in direct support to those on the right (i.e., a unit to the right is a customer of the unit on the left).

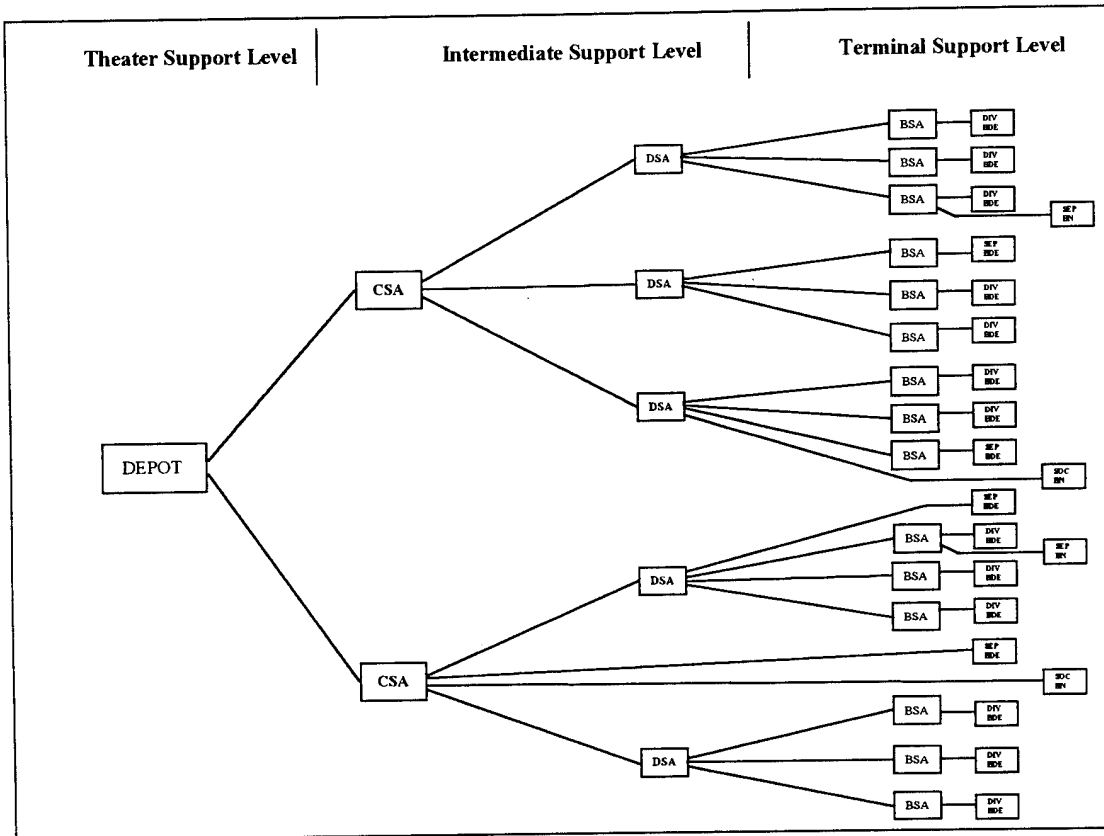

Figure 17. Direct Support Tree.

1. Combat Unit Priorities

A combat unit is assigned a value for its logistical priority based upon its currently assigned mission, its need for supplies, and the potential cost to its supporting unit to deliver the supplies. The priority for a combat unit is calculated according to equation (8).

$$Pr_{su} = \beta_1 MSN_u + \beta_2 \bar{R}_u + \beta_3 Cost_{su} \quad (8)$$

where,

Pr_{su} = the priority of unit u , supported by unit s ;

MSN_u = the current mission assigned to unit u ;

\bar{R}_u = the computed ratio function of supplies on-hand to supplies required for unit u ;

$Cost_{su}$ = the computed cost function for delivering supplies from support unit s to unit u ;

β_i = the weights, determined by the user, assigned to each variable of the priority function, $i = 1, 2, 3$.

The mission assignment value, MSN_u , can take one of seven values defined by the user. Default values for these parameters are illustrated in Table 4. All the MSN_u values are normalized so that an attack mission has the highest priority value of 1.0 and tactical assembly area the lowest value of 0.14.

Mission	Normalized Fraction	MSN_u Value
Attack	7 / 7	1.00
Defend	6 / 7	0.86
Movement to Contact	5 / 7	0.71
Delay	4 / 7	0.57
Tactical March	3 / 7	0.43
Administrative March	2 / 7	0.29
Tactical Assembly Area	1 / 7	0.14

Table 4. Mission Assignment Values, MSN_u .

The value for \bar{R}_u is computed using equation (9). It is the weighted complement of the ratio of supplies on-hand to supplies required for a unit to begin its assigned mission. This parameter yields a higher value for a unit that is critically short of supplies.

$$\bar{R}_u = \omega_p \left(1 - \left(\frac{MBLE_{OHu}}{MBLE_{REQu}} \right) \right) \quad (9)$$

where,

$MBLE_{OHu}$ = the amount of supplies, in MBLE, on-hand at unit u ;

$MBLE_{REQu}$ = the amount of supplies, in MBLE, required at unit u to conduct its mission;

ω_p = the weight assigned to all units of size and type p .

The value for \bar{R}_u is weighted in equation (9) to distinguish among different types of combat units. The user is permitted to choose the weights such that the requirements of a separate mechanized brigade may be weighted more heavily than those of a separate mechanized battalion, or to weight the requirements of a special operations battalion heavier than those of a divisional mechanized brigade. Using these weights allows the combat units to be compared to each other as customers regardless of the size of the units and the magnitude of their requirements.

The value for $Cost_{su}$ is calculated using the methodology included in section D of this chapter. This parameter yields a higher value if there is a lower perceived threat along a route from the supplier to the customer. Therefore, a lower expected loss of supplies and equipment to the supplier gives the customer a higher value for its priority function.

2. Terminal Support Unit Priorities

Once priorities are established for the combat units, support unit priorities are calculated beginning with the terminal support units, such as a BSA. The priority value for a single BSA is a sum of all the priority values for the customer units that it directly supports, according to equation (10).

$$Pr_u = \sum_{k=1}^n Pr_k \quad (10)$$

where,

Pr_u = the priority value for terminal support unit u ;

Pr_k = the priority value for combat unit customer k , $k = 1, \dots, n$.

There is no need to weight the customer unit priority values for BSA customers, because they are already weighted according to equation (9).

3. Intermediate Support Unit Priorities

The priority value for a single intermediate support unit is a sum of all the priority values for the customer units that it directly supports, according to equation (11).

$$Pr_c = \sum_{k=1}^n Pr_k + \sum_{b=1}^m Pr_b + \sum_{d=1}^l Pr_d \quad (11)$$

where,

Pr_c = the priority value for intermediate support unit c ;

Pr_k = the priority value for combat unit customer k , $k = 1, \dots, n$;

Pr_b = the priority value for terminal support unit customer b , $b = 1, \dots, m$;

Pr_d = the priority value for intermediate support unit customer d , $d = 1, \dots, l$.

Since intermediate support units include both CSAs and DSAs, there is the possibility for one intermediate support unit, such as a DSA, to be the customer of another, a CSA. Therefore, it is necessary to include the third summation over intermediate support unit customers. The priorities for all support units are based upon the number of customers they support and the priority values of those customers. Only the requirements of combat units are assigned weights within the model.

4. Theater Support Node Priorities

The priority value for a single theater support node is a sum of all the priority values for the customer units that it directly supports, according to equation (12).

$$Pr_t = \sum_{k=1}^n Pr_k + \sum_{b=1}^m Pr_b + \sum_{c=1}^l Pr_c \quad (12)$$

where,

Pr_t = the priority value for theater support node t ;

Pr_k = the priority value for combat unit customer k , $k = 1, \dots, n$;

Pr_b = the priority value for terminal support unit customer b , $b = 1, \dots, m$;

Pr_c = the priority value for intermediate support unit customer c , $c = 1, \dots, l$.

Equation (12) takes the same form as equation (11), however, because theater support nodes are the only support type that can support a CSA, their priority values are expected to be greater than or equal to all or most CSA support nodes in the model.

D. CALCULATING COST FROM SUPPLIER TO CUSTOMER

The cost of moving a single convoy of trucks from a support unit to a customer may be defined as the amount of supply assets, in supplies and trucks, lost enroute to the customer. This amount is a function of the amount of supply assets initially sent, the transport time to the customer, and the amount of attrition experienced by the convoy along the route. Attrition to the convoy may be caused by ground combat, aerial attack, loss due to obstacles, and non-combat losses such as traffic accidents, fuel spills, etc.

The cost parameter, $Cost_{su}$, from equation (8) is computed as a proportion of supplies lost over the entire convoy route. The equation for the supplies lost over time may be calculated using Lanchester attrition laws as in equation (13). [Ref. 16] The loss rate is assumed to be constant in this equation.

$$\frac{ds}{dt} = -\alpha(s)(E_g) - \beta(s)(E_a) - \tau(s)(E_o) - \eta(s) \quad (13)$$

where,

E_x = the sizes of the respective enemy present along the route to the customer,

(x = ground forces, g , air forces, a , or obstacles, o);

s = the size of the convoy in terms of supply assets sent: stons of supplies, gallons of fuel, or, if the user desires, the size may be defined in terms of trucks;

$\alpha, \beta, \tau, \eta$ = the attrition coefficients for ground, air, obstacle and non-combat losses.

The enemy force sizes, E_x , and attrition coefficients, $\alpha, \beta, \tau, \eta$, are computed using the perception algorithms for enemy air, ground, and obstacle activity either present in JWAEP, or proposed for inclusion under current research.

Since the parameter $Cost_{su}$ is used to find the priority of a customer, the quantities of supply assets sent are not known. A standard convoy size, cs , must be defined as a constant by the user for use in this equation. An example is illustrated in Table 5.

Truck Type	Number of Trucks	Supplies Carried
Small Truck Type	1	2.5 stons
Medium Truck Type	2	5.0 stons
Large Truck Type	1	22.5 stons
HET Truck Type	6	40.0 stons
Fuel Truck Type	2	10,000 gallons

Table 5. Sample Standard Convoy.

The time, t , necessary to send a convoy along its designated route from the support unit to the customer is computed using the model currently included in JWAEP. The parameter $Cost_{su}$ is calculated according to equation (14).

$$Cost_{su} = \text{Max} \left\{ 0, 1 + \left(\frac{ds}{dt} \cdot \frac{t}{cs} \right) \right\} \quad (14)$$

Since ds/dt is a calculation of loss rate per unit time along the route, yielding a negative value, equation (14) computes the parameter $Cost_{su}$ in terms of proportion of the standard convoy, from 0.0 to 1.0, expected to be successfully delivered to the customer, u , along the route from the supplier, s . The parameter $Cost_{su}$ must be a positive value greater than 0.0 since the convoy cannot lose more assets than it is transporting.

E. RESUPPLY REQUESTS

There are two broad systems of supply that are used in the logistics model for JWAEP. For the purposes of this research, these systems are defined as:

The *Push* System: In this system, customer requests are filled by the supporting units using a forecast of the maximum amount of supplies the customer will need based upon the customer's recent consumption activity. This is the "status quo" supply system used for day-to-day operations.

The *Pull* System: In this system, the customer's needs override the "status quo" procedures. The pull system is initiated by the customer, either due to a change of mission which requires the customer to have more supplies on-hand, or because the customer's supply levels have dropped below a pre-defined threshold (defined by the user), causing a need for immediate resupply. A customer uses the pull system until its requirements are met, at which time it reverts back to the push system.

Every unit that is a customer of another has a binary supply system descriptor, distinguishing whether it is currently using the push or pull system. This descriptor is included in the instance definition for the unit as **SSD**. A “0” signifies the push system and a “1” the pull system.

1. The Push System

The push system of supply for the JWAEP model uses recent supply activity to forecast and send forward quantities of supplies predicted to fill the customer’s immediate and near term needs. The forecast model proposed for resupply requests is a point estimate, computed using an exponentially weighted moving average of recent consumption. Equation (15) is used to compute the push system forecast, R_{uD} .

$$R_{uD} = \varpi_{(d-1)}C_{u(d-1)} + \varpi_{(d-2)}C_{u(d-2)} + \varpi_{(d-3)}C_{u(d-3)} \quad (15)$$

where,

R_{uD} = the forecasted resupply request for unit u on day D ;

$C_{u(d-i)}$ = the ground truth consumption of supplies for unit u , (either ammunition or POL), on the preceding i days, $i = 1, 2, 3$;

$\varpi_{(d-i)}$ = the exponential weight assigned to days $(d-i)$, $i = 1, 2, 3$.

The value for the assigned weights placed on the consumption for the three days prior to d is computed according to equation (16). ($\varpi_{(d-i)} \equiv 0$ for $d < i$).

$$\varpi_{(d-i)} = \lambda e^{\lambda(d-i)} \quad (16)$$

where,

$\varpi_{(d-i)}$ = the exponential weight assigned to day $(d-i)$, $i = 1, 2, 3$;

λ = the scale parameter, chosen by the user, to determine the size of the weights assigned to consumption for previous days.

The forecasted request value for a single day is an upper limit on the amount of supplies that can be sent to the customer unit, if its supplier has the supply assets available.

2. The Pull System

In the pull system the support unit no longer uses the resupply forecast, equation (15), to fill the customer’s requirements. The customer’s requirements increase due to

shortage or mission priority, causing its logistical priority to increase. The customer initiates a new request for the difference between its $MBLE_{REQ}$ and $MBLE_{OH}$. The support unit re-calculates its customers' logistical priorities and begins to fill customers' requirements as described below. Since a customer may initiate the pull system at any time during a logistics cycle, any supply assets that are already dedicated (i.e., have either departed in convoys or are being loaded into trucks) are considered to be unavailable. Supply assets undesignated or designated for use by other customers, but waiting to be loaded, are used to re-compute and fill the new supply requests.

All logistical units are able to use both the push and pull supply systems; however, only terminal support units have a designated mission, such as attack, defend, delay, etc. Terminal support units supporting a separate or divisional brigade have the same mission as their customer brigades. Intermediate and theater support units do not have a designated mission, thus they only use the pull system when their $MBLE_{OH}$ drops below the designated threshold of their $MBLE_{REQ}$.

3. Filling Supply Requests

Before a support unit is able to establish convoys and deliver supplies to its customers, it must have the following information for all of its customers:

- Priority values.
- Resupply request values.
- Supply system descriptors.
- Distance from the support unit.

Using this information, support units begin to apportion their supplies and trucks available by giving additional weight to those customers using the pull system, $SSD = "1"$. The additional weight assigned to these customers is determined by the user; a planning factor weight between 1.5 and 2.0 is suggested. The purpose of this weight is to increase the priority values of those customers using the pull system, since they are considered to be critically short of supplies. The customers are then placed into a priority queue, using their adjusted priority values as the discriminator.

Depending upon the supplies on-hand, trucks available, and MHE available at the support unit, along with the time required to execute a single convoy to each customer, the potential exists in both the push and pull systems for the support unit to run continuous convoys to all or some of its customers in order to completely fill a supply request. Due to this potential, logistics processes operate on a cycle at each echelon of support. Supply requests are re-evaluated at the beginning of each cycle, such that any portion of a customer's supply request not filled in a single cycle will be included in the customer's request for the next cycle, as long as the customer continues to have the same requirements and priority. Cycle lengths at each support echelon are left to the user's discretion.

a. Unconstrained Assets

The least interesting case for the support unit is when it has an amount of supplies, trucks, and MHE available sufficient to fill all of its customers' requests using a single convoy for each customer, as in equations (17),(18) and (19). In such a circumstance, the unit fills all of the requests beginning with the highest priority unit.

$$(Supplies\ on\ hand)_{st} \geq \sum_{c=1}^k (Supply\ Requests)_{ct} \quad \forall \text{ supply types } t \quad (17)$$

where,

$(Supplies\ on\ hand)_{st}$ = the supplies of type t on-hand at support unit s ;

$(Supply\ Requests)_{ct}$ = the supply request for customer c of supply type t ,

$c = 1, \dots, k$, where k is the number of customers for support unit s .

$$(Trucks\ on\ hand)_{sv} \geq \sum_{c=1}^k (Trucks\ Required)_{cv} \quad \forall \text{ truck types } v \quad (18)$$

where

$(Trucks\ on\ hand)_{sv}$ = the number of trucks of type v available at support unit s ;

$(Trucks\ Required)_{cv}$ = the number of trucks of type v required to fill the request of customer c , $c = 1, \dots, k$.

$$\theta(MHE_s * Cycle Length)_s \geq \sum_{c=1}^k (MHE_{REQc}) \quad (19)$$

where

- MHE_s = the number of MHE systems in operation at the support unit s ;
 θ = the proportion of MHE time at the support unit dedicated to fill customer convoys. $(1 - \theta)$ is the proportion of time dedicated to off-loading incoming supplies at the support unit;
 MHE_{REQc} = the MHE time required to fill the convoy for customer c .

$(Trucks Required)_{cv}$ is a vector parameter whose elements, for a single customer c , are calculated according to the algorithm below.

For $(Supply Requests)_{ct}$, where $t =$ supply type (Ammunition) {
 For all truck types $v = 1$ to 4 {
 (Truck types are defined as 1 = HET, 2 = Large, 3 = Medium, 4 = Small)
 If $v = 4$ {
 $(Trucks Required)_{cv} = \text{Max} (0, \text{round}(((Supply Request)_{ct} / (Truck Capacity)_v) + 0.5)$
 $(Trucks on-hand)_{sv} = (Trucks on-hand)_{sv} - (Trucks Required)_{cv}$
 $(Supply Request)_{ct} = (Supply Request)_{ct} - ((Trucks Required)_{cv} * (Truck Capacity)_v) }$
 else {
 $(Trucks Required)_{cv} = \text{Max} (0, \text{trunc}(((Supply Request)_{ct} / (Truck Capacity)_v))$
 $(Trucks on-hand)_{sv} = (Trucks on-hand)_{sv} - (Trucks Required)_{cv}$
 $(Supply Request)_{ct} = (Supply Request)_{ct} - ((Trucks Required)_{cv} * (Truck Capacity)_v) }$
 For $(Supply Requests)_{ct}$, where $t =$ supply type (Fuel) {
 For truck type $v = 5$ {
 (Truck type 5 = Fuel)
 $(Trucks Required)_{cv} = \text{Max} (0, \text{round}(((Supply Request)_{ct} / (Truck Capacity)_v) + 0.5)$
 $(Trucks on-hand)_{sv} = (Trucks on-hand)_{sv} - (Trucks Required)_{cv}$
 $(Supply Request)_{ct} = (Supply Request)_{ct} - ((Trucks Required)_{cv} * (Truck Capacity)_v) }$ }

The support unit fills the request using as few trucks as possible, filling each truck to capacity. Exceptions to this rule occur when there is a remaining amount that will not fill the smallest truck available. In such a case, one truck will be included in the convoy that is not filled to capacity. This exception will almost always occur for fuel

trucks, since there is only one fuel truck type presently defined in the model. Each element in the vector $(Trucks\ Required)_{cv}$ contains the number of trucks of type, v , being sent to customer c .

b. Constrained Assets

When the supply assets, supplies on-hand, trucks available, or MHE availability are limited, the support unit must decide how to apportion its assets to its customers. Several solutions are available. The most viable option is to supply as many units as possible beginning with the highest priority unit, until the support unit's assets are depleted. An alternative is to apportion the assets such that supplies are sent to each customer proportional to its priority value normalized over all customers. Future research may be done to include both of these solutions and others; however, this study proposes a methodology that uses the latter solution for apportionment.

The methodology for all three supply assets is similar: it begins by normalizing the priority values for all customers according to equation (20). This equation gives the maximum proportion of supply assets that may be allocated to customer c .

$$NPr_c = \frac{Pr_c}{\sum_{c=1}^k Pr_c} \quad (20)$$

where,

- NPr_c = the normalized priority proportion for customer c ;
- Pr_c = the priority value for customer c , from equations (8), (10), (11), or (12),
 $c = 1, \dots, k$, where k is the number of customers for the support unit.

Beginning with its highest priority customer, the support unit allocates an amount of supplies as the minimum of the customer's request and the proportion of supplies on-hand that the customer may receive according to its normalized priority proportion. If the customer's request is less than its allowable proportion, the difference between the two is made available to units with lower priority values. The support unit allocates supplies to each of its customers in this manner in order of priority.

The support unit next allocates MHE time available to each customer. Total MHE time available is computed according to equation (21).

$$TimeMHE = \theta \sum_{m=1}^n MHE_m * CycleTime \quad (21)$$

where,

- $TimeMHE$ = the total hours of MHE usage available in the cycle;
- MHE_m = the number of MHE systems of type m that the support unit can operate, $m = 1, \dots, n$, where n is the number of MHE system types;
- θ = the proportion of MHE time at the support unit dedicated to fill customer convoys. $(1 - \theta)$ is the proportion of time dedicated to off-loading incoming supplies at the support unit;
- $CycleTime$ = the number of hours in a support cycle.

The total MHE time available is allocated to customers as if it were another supply type. However, the MHE time allocated to a customer is determined to be the minimum of the time needed to load the supplies it has been allocated or its prioritized proportion of total MHE time available. When the customer's MHE time allocation is determined by its prioritized proportion, a comparison is done between the previous supply allocation and the amount of supplies that can be loaded using the customer's MHE time. This amount becomes the customer's new supply allocation.

The last consideration is to determine the numbers, by type, of trucks to be allocated to the customers' convoy(s). Similar to the methodology use in TACWAR, the first step in this process is to determine the number of round trips that a single convoy can make during one logistics cycle. [Ref. 7] The number of round trips is determined as a function of the following information:

- The distance between the support unit and the customer.
- The movement rate of a convoy along the route.
- The time needed to load and unload supplies at both supplier and customer.

- The time available to resupply the unit during the cycle.³

The customer's supply request is then factored by the number of round trips, and this value is used to determine the number of trucks needed for a single convoy to the customer using the same algorithm outlined for unconstrained assets to find the vector (*Trucks Required*)_{cv}. The support unit compares this vector to a second (*Trucks Required*)_{cv} vector, calculated using the priority proportions to apportion the support units trucks available, and rounding down to yield integer elements for this second vector. Each element of the two (*Trucks Required*)_{cv} vectors is compared to determine the minimum number of trucks to be dedicated to a customer during the cycle. These minimum values are the actual elements used for the (*Trucks Required*)_{cv} vector. The final comparison to be made is to find the minimum value for customer supply allocation using the previous supply allocation and the total amount of supplies that can be transported in the number of round trips made to the customer during the cycle.

F. LOGISTICAL FEASIBILITY

Calculating the logistical feasibility of a course of action allows the decision maker to determine whether a course of action is supportable and to quantify the amount of risk involved in a course of action, in terms of the ratio of supplies available to supplies required.

A logistical course of action for a support unit is described by the combat assignments for all of its customers. As a review, only combat units and terminal support units are given mission orders (e.g., attack, defend, delay, etc.). As it pertains to a combat unit, a course of action in the JWAEP model is described by a mission order and a path of arcs and nodes upon which to conduct the mission. For ease of explanation, logistical courses of action for a support unit at any support echelon are described by the mission orders assigned to all of the support unit's terminal support unit and combat unit customers. For example, a DSA supporting three BSAs and a separate infantry brigade could have a logistical course of action defined as follows: (BSA1 = Attack, BSA2 =

³ This information is important in later sections to determine the logistical feasibility of a course of action. Otherwise, the total cycle length is used.

Attack, BSA3 = Delay, BDE = Defend). Logistical courses of action for a support unit differ only by the mission orders given to its customers.

When comparing logistical courses of action for feasibility, the decision maker is attempting to determine the probability that a customer's requirements can be met to a certain degree, under given conditions. The given conditions are primarily the logistical courses of action for the support unit and the logistical priorities of its customers, including customers not assigned a mission order. For example, a CSA supporting two DSAs, three BSAs, and a separate infantry brigade has a logistical course of action defined by the mission orders of the BSAs and the separate brigade. However, it must take into consideration the support required by the two DSAs when estimating the feasibility of a logistical course of action.

The feasibility of a course of action is quantified as the probability that a customer can have a given proportion of its required supplies on-hand by a specified time. The proportions are specified by the user and are an attempt to quantify the amount of logistical risk involved for each customer under a logistical course of action. An example of the proportions that may be chosen to describe this risk is given in Table 6.

RISK	Category, Q	Proportion of Requirement On-hand, U
None	1	$u > 0.90$
Slight	2	$0.90 \geq u > 0.75$
Moderate	3	$0.75 \geq u > 0.60$
High	4	$0.60 \geq u > 0.00$

Table 6. Sample Risk Categories.

The feasibility of a support unit's logistical course of action is dependent upon the following:

- Amount of supplies on-hand at the support unit and its customers.
- Amount of time available to resupply customers.
- Priority values of its customers under a given logistical course of action.
- Supply allocations for all customers under a given logistical course of

action.

- Amount of supplies arriving at the support unit.
- Customers' supply consumption.
- The probability and effectiveness of ground attack at the support unit, its customers, and the convoy routes between them.
- The probability and effectiveness of aerial attack at the support unit, its customers, and the convoy routes between them.
- The probability and effectiveness of obstacles along the convoy routes between the support unit and its customers.

Mission assignments in the JWAEP model are given a time of execution and a specific duration for the mission. In the interactive mode the default time of execution is the time at which the order is given. Under interactive conditions, some reasonable assumptions must be made concerning the average time available to resupply units, depending upon the missions that they are assigned. Table 7 defines the recommended amounts of time available to resupply units under the seven types of mission orders. The times included in Table 7 are used as reference for the remainder of this section; however, the user is permitted to define them in the actual model.

Mission	Time Available
Attack	1 day (24 hours)
Defend	1 days (24 hours)
Movement to Contact	1.5 days (36 hours)
Delay	1.5 days (36 hours)
Tactical March	2 days (48 hours)
Administrative March	2 days (48 hours)
Tactical Assembly Area	2.5 days (60 hours)

Table 7. Recommended Mission Resupply Times.

In the non-interactive mode, the default calculation used to find a unit's resupply time available is the difference between the time of execution for the order and the time the order was received by the unit.

1. Expected Amount of Supplies On-hand at End of Resupply Time

The first step to determine the logistical feasibility of a course of action is to calculate the expected amount of supplies on-hand at the end of the customer resupply times. Using the methods outlined in previous sections it is possible to calculate the supply allocations for each customer of the support unit, given a logistical course of action, the priority values of the customers, and the supply assets available at the support unit.

Additionally, using equations similar to equation (13) and substituting the known supply allocation for s , it is possible to calculate the expected daily supply losses along the supply route to the customer, Lr_d , losses at the customer due to combat, Lc_d , and the daily consumption of the customer, Cc_d . Since the losses are aggregated random variables generated in the ATCAL / COSAGE simulation, the parameters for combat loss and consumption are assumed to be distributed normally as justified by the central limit theorem. Using the methodology outlined to fill supply requests and estimating the daily amount of supplies arriving at the support unit using the forecast for the push system found in equation (15), the daily supply allocation for a customer, $MBLE_d$, can be computed. A general equation for the expected amount of supplies on-hand for a single customer at the end of its resupply time, $MBLE_{OH,t+\delta}$, is given in equation (22).

$$E[MBLE_{OH,t+\delta}] = MBLE_{OH,t} + \sum_{d=1}^{\delta-\rho} MBLE_d - E[Lr_d] - E[Lc_d] - E[Cc_d] \\ \rho [MBLE_{(\delta-\rho+1)} - E[Lr_{(\delta-\rho+1)}] - E[Lc_{(\delta-\rho+1)}] - E[Cc_{(\delta-\rho+1)}]] \quad (22)$$

where

$MBLE_{OH,t}$ = the beginning amount of supplies on-hand at the customer at time t ;

$\delta - \rho$ = the integer days allowed for resupply, where ρ is a portion of the last day;

$\delta - \rho + 1$ = the last day of the resupply time.

It is important to note that the expected supplies on-hand at the end of their respective resupply times must be calculated for all customers defined in the logistical course of action of the support unit. The daily supply allocations for all customers are dependent upon their priority values and the customers' placement in the support unit's priority list. Therefore, the $MBLE_{OH,t+\delta}$ for an attacking unit with a one day resupply time will be computed before that of a unit assigned a tactical march mission, which has a two day resupply time. However, the former unit's supply consumption and allocation must still be accounted for in the $MBLE_{OH,t+\delta}$ calculations for the latter.

2. Logistical Feasibility

The logistical feasibility for a course of action can now be computed. Equation (21) calculates the expected value of the supplies on-hand at the customer at the end of its resupply time, $MBLE_{OH,t+\delta}$. However, because of the stochastic nature of the JWAEP model, there is some probability that this value is more, or less, than its expected value. This value has a definite upper bound determined by the sum of its beginning supplies on-hand, $MBLE_{OH,t}$, and the total supplies that it may receive from its supplier from t to $(t+\delta)$, $\sum_{d=1}^{\delta} MBLE_d$. This sum is defined as $M_{(t+\delta)}$ in equation (23). It is the maximum amount of supplies available to the customer when there are no losses due to combat and consumption, from time t to $(t+\delta)$.

$$M_{(t+\delta)} = MBLE_{OH,t} + \sum_{d=1}^{\delta} MBLE_d. \quad (23)$$

The stochastic nature of $MBLE_{OH,t+\delta}$ lies in the variability of the total losses and consumption at the customer during the time t to $(t+\delta)$. The expected value of the total loss of supplies at the customer c may be calculated, as in equation (24), as the sum of the expected losses over the time t to $(t+\delta)$, given $M_{(t+\delta)}$.

$$E[TL_{c,t+\delta} | M_{(t+\delta)}] = \sum_{d=1}^{\delta-\rho} \left[E[Lr_d | M_{(t+\delta)}] + E[Lc_d | M_{(t+\delta)}] + E[Cc_d | M_{(t+\delta)}] \right] + \rho \left[-E[Lr_{(\delta-\rho+1)} | M_{(t+\delta)}] - E[Lc_{(\delta-\rho+1)} | M_{(t+\delta)}] - E[Cc_{(\delta-\rho+1)} | M_{(t+\delta)}] \right] \quad (24)$$

Since each of the random variables for losses is assumed to be normally distributed, the probability distribution for the total losses of supplies can be described by a Normal distribution with mean = μ and variance = σ^2 . The mean of the distribution, μ , is equal to the maximum available supplies less the expected value of the total losses at time $(t + \delta)$, $M_{(t + \delta)} - E[TL(t + \delta)]$. The standard deviation (SD) is calculated in the ATCAL / COSAGE model, and used to define the distribution for total losses.

The logistical feasibility for a customer in a logistical course of action is found by computing the probability that the proportion, U , is identified by one of the risk categories, Q , described by Table 7, where

$$U = (MBLE_{OH,t + \delta} / MBLE_{REQ}) \quad (25)$$

and

$$U_{MAX} = (M_{(t + \delta)} / MBLE_{REQ}). \quad (26)$$

Therefore, the logistical feasibility for a customer in a single category, q , may be described by equation (27).

$$P\{Q = q\} = P\{l < u \leq h \mid U_{MAX} = u_{max}\} \quad (27)$$

where,

l = the lower bound of the risk category, q ;

h = the upper bound of the risk category, q .

Figure 18 is a visual example of how the probabilities for logistical feasibility are computed for a unit. In the example, the unit's requirements are for 3.0 MBLE. The computed maximum supplies available at $(t + \delta)$, $M_{(t + \delta)}$, are 2.56 MBLE. The expected total losses, $E[TL_{c,(t + \delta)}]$, were calculated to equal 0.42 MBLE. Therefore, the distribution for the probability mass function is centered at 2.14 MBLE = 2.56 - 0.42 MBLE, with a standard deviation chosen to be 0.14. According to equation (26), U_{MAX} , the maximum proportion of its required supplies that this unit is able to have on-hand by time $(t + \delta)$, equals 2.56 / 3.00, or 0.853. Immediately, the probability that $Q = 1$, $0.90 < u \leq 1.00$, is found to be 0.00, because it is known that $U_{MAX} = 0.853$.

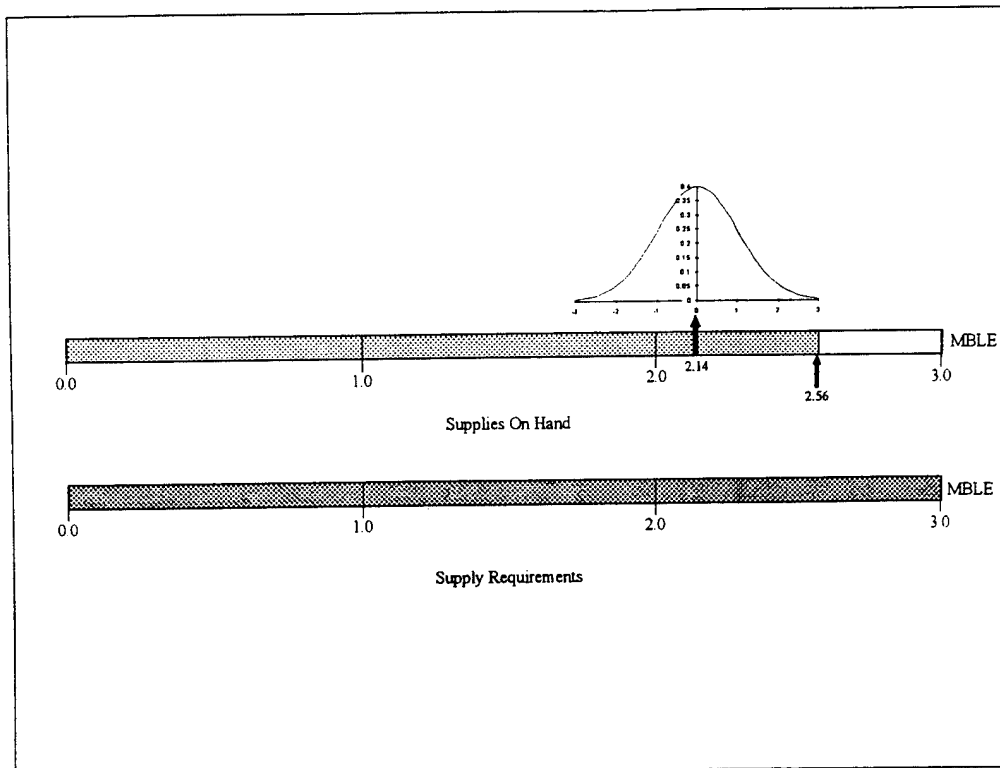

Figure 18. Logistical Feasibility Example.

The probabilities for the other three categories of Q are computed by summing across the probability mass function over the interval that characterizes those categories. The probabilities for each category of logistical feasibility for this example are found in Table 8.

RISK	Category, Q	Proportion On-hand, U	Probability
None	1	$u > 0.90$	0.00
Slight	2	$0.90 \geq u > 0.75$	0.22
Moderate	3	$0.75 \geq u > 0.60$	0.77
High	4	$0.60 \geq u > 0.00$	0.01

Table 8. Logistical Feasibility Example.

The combined probabilities for each unit in a logistical course of action result in a $k \times 4$ matrix, where k equals the number of customers included in the logistical course of action.

$$\begin{bmatrix} q_{11} & q_{12} & q_{13} & q_{14} \\ q_{21} & q_{22} & q_{23} & q_{24} \\ \dots & \dots & \dots & \dots \\ q_{k1} & q_{k2} & q_{k3} & q_{k4} \end{bmatrix}$$

A matrix for each logistical course of action must be computed for comparison by the decision maker in order to determine the most supportable course of action. Deciding which course of action is best is still left to the decision maker. The probability matrices for the logistical courses of action are another tool for the decision maker to use.

For a single decision, the decision maker may have several options from which to choose a course of action. For example, a decision maker deciding the missions of three combat brigades may want one unit to attack while one defends and the third conducts a delay. If all three units are capable of doing any of the missions, the decision maker may look at the logistical feasibility matrices to find the unit assignment combination that is most supportable. Table 9 illustrates the possible mission assignment combinations available to the decision maker.

Unit	CoA 1	CoA 2	CoA 3	CoA 4	CoA 5	CoA 6
BDE 1	<i>Attack</i>	<i>Attack</i>	<i>Defend</i>	<i>Defend</i>	<i>Delay</i>	<i>Delay</i>
BDE 2	<i>Defend</i>	<i>Delay</i>	<i>Delay</i>	<i>Attack</i>	<i>Attack</i>	<i>Defend</i>
BDE 3	<i>Delay</i>	<i>Defend</i>	<i>Attack</i>	<i>Delay</i>	<i>Defend</i>	<i>Attack</i>

Table 9. Example Course of Action (CoA) assignments.

Where the logistical feasibility matrices are:

$$\begin{array}{ccc} \text{CoA 1} & \text{CoA 2} & \text{CoA 3} \\ \begin{bmatrix} 0.00 & 0.12 & 0.72 & 0.16 \\ 0.01 & 0.18 & 0.66 & 0.15 \\ 0.03 & 0.26 & 0.45 & 0.26 \end{bmatrix} & \begin{bmatrix} 0.19 & 0.42 & 0.45 & 0.16 \\ 0.16 & 0.58 & 0.20 & 0.06 \\ 0.25 & 0.46 & 0.21 & 0.08 \end{bmatrix} & \begin{bmatrix} 0.00 & 0.07 & 0.43 & 0.50 \\ 0.00 & 0.08 & 0.56 & 0.34 \\ 0.00 & 0.10 & 0.33 & 0.57 \end{bmatrix} \end{array}$$

CoA 4	CoA 5	CoA 6
$\begin{bmatrix} 0.01 & 0.12 & 0.22 & 0.65 \\ 0.00 & 0.03 & 0.15 & 0.82 \\ 0.00 & 0.09 & 0.25 & 0.66 \end{bmatrix}$	$\begin{bmatrix} 0.12 & 0.36 & 0.33 & 0.29 \\ 0.09 & 0.25 & 0.44 & 0.22 \\ 0.21 & 0.26 & 0.35 & 0.19 \end{bmatrix}$	$\begin{bmatrix} 0.03 & 0.19 & 0.25 & 0.53 \\ 0.07 & 0.25 & 0.36 & 0.32 \\ 0.05 & 0.21 & 0.41 & 0.33 \end{bmatrix}$

A comparison of the six logistical feasibility matrices reveals that CoA 2 is most logistically feasible, because it contains the highest probability of achieving greater than 70% of the support requirements needed at each unit, under the assigned missions of that CoA. Of course, this is only one example and the decision maker may use any decision criteria he or she chooses.

V. TESTING THE METHODOLOGY

A. GENERAL

The purpose of this chapter is to investigate the reasonableness of the methodology introduced in Chapter IV to model the logistical constraints on the courses of action. The primary focus of this discussion concerns the methodologies for establishing unit priorities and for computing the logistical feasibilities of different courses of action. An analytical spreadsheet model is used as the primary tool to conduct the logistical constraint analysis.

B. SCENARIOS FOR INVESTIGATION

Three scenarios were investigated involving an intermediate support unit (DSA) supporting three terminal support unit (BSA) customers. Customer units were assigned a mission and a supply need, characterized as "high" or "low", to describe the supply needs of the unit at the start of the scenario. A "high" supply need means the unit's needs are high. In the scenarios, the units need 50% of their required supplies when their supply need is "high". A "low" supply need indicates the unit's needs are low, only 16% to 20% of its required supplies are needed to be fully supplied. Each scenario was investigated using three different combinations of supply need for the customers, such that the effects of the supply need on priority values could be demonstrated. Table 10 illustrates the three different scenarios and their respective supply need combinations.

	Scenario 1			Scenario 2			Scenario 3		
Unit	BSA 1	BSA 2	BSA 3	BSA 1	BSA 2	BSA 3	BSA 1	BSA 2	BSA 3
Mission	Attack	Attack	Defend	Defend	Attack	Defend	Delay	Attack	Delay
Need 1	High	High	High	High	High	High	High	High	High
Need 2	Low	Low	High	High	Low	High	High	Low	High
Need 3	Low	High	High	High	Low	Low	Low	Low	High

Table 10. Investigated Scenarios.

The "high" and "low" supply need characterizations for each customer were determined as a function of the mission type that was assigned to the customer. For both "attack" and "defend" missions, the customer was required to have 3.00 MBLE. Recall

1. Priority Values

In the first set of scenarios the three BSAs were assigned missions of “attack”, “attack”, and “defend”, respectively. The priority values were calculated according to equation (8), in Chapter IV, section C. Based solely on mission assignment and the priority values assigned to those missions, it would be expected that the two attacking units would get primary but equal priority, and the defending unit would get last priority. The results of this set of scenarios are provided in Table 11.

Unit	Mission	Need	Priority Value	Need	Priority Value	Need	Priority Value
BSA 1	Attack	High	5.0468	Low	3.7968	Low	3.7968
BSA 2	Attack	High	5.0468	Low	3.7968	High	5.0468
BSA 3	Defend	High	4.7668	High	4.7668	High	4.7668

Table 11. Scenario Set 1, Priority Value Results.

As expected, when the supply need for each of these customers is the same, as in the “high”, “high”, “high” scenario, the model yielded reasonable results. Even though the customers have equal supply needs, the defending BSA gets a slightly lower priority value due to the lower mission assignment value for “defend”. However, in the “low”, “low”, “high” scenario, using the same mission assignments, the model makes the adjustment for the attacking BSAs having less need than the defending BSA and rank BSA 3 as the top priority, followed by BSA 2 and BSA 1 with equal priority values. The third supply need combination for this scenario was “low”, “high”, “high”. As expected, BSA 2 took on the highest priority value followed by BSA 3, and then BSA 1.

The remaining scenario sets yielded similar results to scenario set 1. Therefore, priority values and proportions generated by the model passed the author’s test for reasonableness.

2. Logistical Feasibility Matrices

One example from each of the three scenario sets is provided for this review of results. In each case, the supply needs of two units are set to low and one is set to high. The results for these examples of logistical feasibility are displayed in Table 12.

Unit	Mission	Need	Q = 1	Q = 2	Q = 3	Q = 4
			$u > 0.90$	$0.90 \geq u > 0.75$	$0.75 \geq u > 0.60$	$0.60 \geq u > 0.00$
BSA 1	Attack	Low	0.0578	0.6564	0.2824	0.0034
BSA 2	Attack	Low	0.0578	0.6564	0.2824	0.0034
BSA 3	Defend	High	0.0000	0.0156	0.6020	0.3824
BSA 1	Defend	High	0.0000	0.0414	0.7037	0.2548
BSA 2	Attack	Low	0.0524	0.6197	0.3219	0.0060
BSA 3	Defend	Low	0.0524	0.6197	0.3219	0.0060
BSA 1	Delay	Low	0.0350	0.4536	0.4717	0.0397
BSA 2	Attack	Low	0.0578	0.6564	0.2824	0.0034
BSA 3	Delay	High	0.0002	0.0703	0.6458	0.2837

Table 12. Logistical Feasibility Results.

Recall from Chapter IV, that the feasibility category, Q, is defined by the inequalities on u, where u is the proportion of supplies on-hand to supplies required expected at the unit at the end of its available resupply time. As expected, the probability of achieving higher proportions of supplies on-hand at the end of the resupply cycle were primarily dependent upon the level of need at which the customer began. Recall that the cost and expected loss functions were not varied in the scenarios. However, the results also show that the probability of achieving higher proportions of supplies on-hand is dependent not only upon the mission assigned to the unit in question, but upon the missions and needs of the sister units that are being supported by the same supplier. Figures 19 through 21 plot the probabilities of the feasibility categories, Q, for the three scenarios from Table 12.

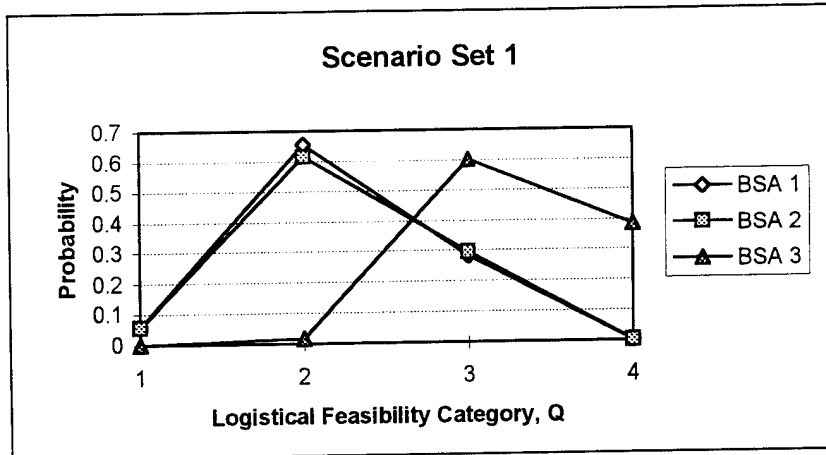

Figure 19. Scenario Set 1 Probability Plot.

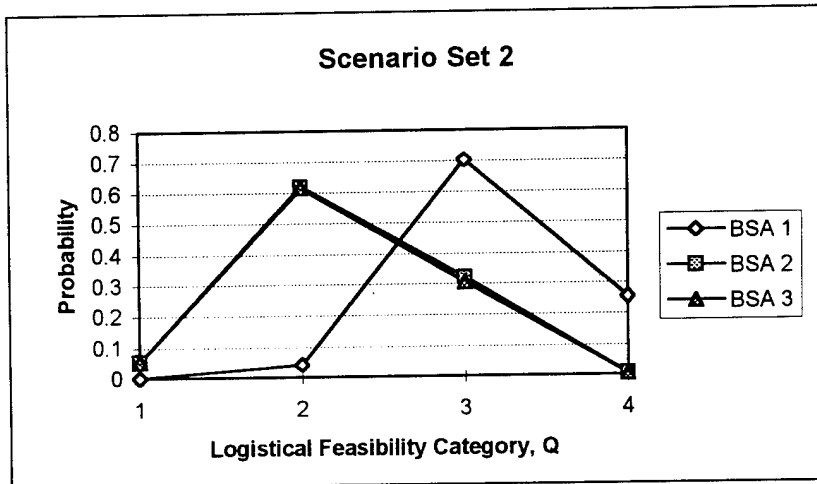

Figure 20. Scenario Set 2 Probability Plot.

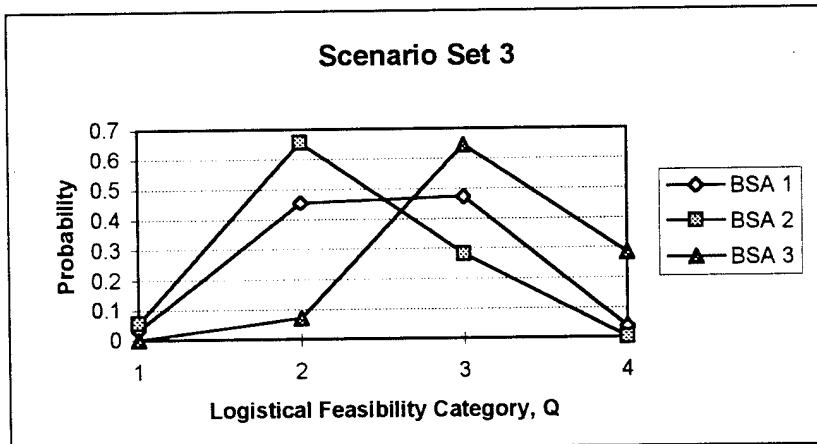

Figure 21. Scenario Set 3 Probability Plot.

BSA 2 is assigned the same mission and supply need in all three examples. In the first and third scenario sets the probabilities are the same for BSA 2 across all categories, Q . In the second scenario it has a slightly decreased probability of getting more than 75% of its required supplies, $Q = 1$ or $Q = 2$. This example is highlighted to point out the dynamics of the algorithm.

The robustness of the model is demonstrated in a comparison of the units from each scenario that have a “high” need for supplies. The probability that these units get greater than 90% of their required supplies by the end of their resupply cycle is very small. In scenario set 1, BSA 3 has a probability vector of (0.0000, 0.0156, 0.6020, 0.3824) for feasibility categories $q = 1, \dots, 4$. In the other scenario sets, 2 and 3, the “high” need units have vectors of (0.0000, 0.0414, 0.7037, 0.2548) and (0.0002, 0.0703, 0.6458, 0.2837), respectively. Summing across the first three categories of q yields the probability of having more than 60% of the unit’s required supplies by the end of the resupply time. For scenario set 1 this probability is 0.6176, likewise for scenario sets 2 and 3 the probabilities are 0.7451 and 0.7163, respectively. In the first two scenarios, the only parameter being varied, with respect to the “high” need unit, is the mission of one of the “low” need units. Yet, the “high” need unit in scenario 2 has an increased probability of 13% that it will obtain greater than 60% of its supplies in the same amount of time. In the third scenario the probability of the “high” need unit obtaining greater than 60% of the required supplies is reduced slightly, primarily due to the decreased priority value assigned to a delaying unit as opposed to the defending unit used in scenarios 1 and 2.

VI. CONCLUSIONS AND FUTURE STUDY

A. CONCLUSIONS

The objectives of this thesis are to provide a methodology and structure to provide a logistical model that may be integrated into the Joint Warfare Analysis Experimental Prototype, or other theater level combat models and, using this structure, to describe the methods and algorithms to give the combat model the capability to use this logistical structure as a planning constraint to aid the decision maker.

As with any theater level model, an implicit objective of this thesis is to provide enough realism in the model to allow it to provide useful results, while at the same time limiting its scope so that it does not burden either the hardware on which it is run or the analyst who is asked to use it. The goal is to make the combat and logistics models of a single simulation work hand-in-hand, rather than analyzing combat on one simulation and analyzing the results on a separate post-processor to derive the expected logistical outcomes.

The proposed model for the logistical structure of JWAEP will work using the same arc-node structure already present in the combat model, and only modify the data structures of JWAEP necessary to convert combat units into logistical units. The methodologies and algorithms proposed that use the logistical structure as a planning constraint appear to yield the intended results in an analytical spreadsheet model. Naturally, since this is the first effort proposed to add a logistical model to JWAEP, further study should be done to verify and validate the results of the model.

In reference to the spreadsheet model, it is interesting to note that in every case where the supply need of a unit was "high" there was an exceptionally low probability that the unit would achieve greater than 90% of its required supplies in the amount of time provided. This is reasonable according to the model, but is perhaps not entirely realistic in terms of military capabilities. The ability of a support unit to surge its capabilities and draw assets from direct and general support units for short periods of time is not modeled. Additionally, the use of helicopter and airdrop resupply is not modeled. However, these

results should not detract from the value of the model to the decision maker. In fact, quite the opposite is true, because in knowing that the unit has a small probability of meeting its requirements, the decision maker is given information which allows him or her to make the decision to call for more assets in order to meet the requirements of the customer.

B. FUTURE STUDY

The first area recommended for future study is the implementation of code for the developmental version of the logistical model that may be integrated into JWAEP for evaluation and testing. The lack of a logistical model in the current version of JWAEP is a gap in the simulation which must be filled in order for research done with JWAEP to be complete.

Once a logistical model is integrated in the simulation, a sensitivity analysis of the algorithms presented in this thesis is recommended to investigate realistic bounds for the parameters of the model.

Additional research is proposed to optimize the resupply allocation algorithms. The algorithms proposed in this thesis are heuristic and are based primarily on the apportionment of supply assets according to priority value assignment. These algorithms may be expanded in future research to use linear or non-linear programming to obtain optimal solutions to the asset apportionment problem. Additional consideration may be made to allow the decision maker to choose the apportionment methodology from among several options.

Future study is recommended to investigate the ability of the ATCAL / COSAGE model to generate dynamic databases that may be incorporated into the JWAEP logistical model. The details of how these databases will be incorporated into the JWAEP model are yet to be developed.

Future research into the algorithms necessary for inclusion of tactical and theater aerial resupply models is also recommended. Such models would include the capability for the model to represent theater airbases for air force and ground resupply. Additional capabilities to be modeled are logistical airdrops and helicopter resupply operations. Modeling the naval resupply system is also recommended as the logistics model matures.

APPENDIX

This appendix includes the compiled results for the priority values, priority proportions, and logistical feasibility matrices from the nine different scenarios analyzed in the spreadsheet model. Additionally, the spreadsheet data from a single run of the model are included as an example. The actual *EXCEL* spreadsheets analyzed for this thesis are available from Dr. Sam Parry, OR Department, Naval Postgraduate School, Monterey, California 93943-5000.

The tables presented in this appendix are extracted from the spreadsheet model. Additional information is used to illustrate the methodologies of Chapter IV and how they are implemented in the spreadsheet. Equations defined in the thesis are presented here for ease of understanding; additionally, the parameter labels used in the thesis are presented in bold print in the tables for further clarification.

Table 13 presents the weight constants used in equations (8) and (9), from Chapter IV, to determine priority values.

β_1	Beta1	2.0000
β_2	Beta2	3.0000
β_3	Beta3	1.5000
ω_p	wbsa	1.2500

Table 13. Weight constants.

$$Pr_{su} = \beta_1 MSN_u + \beta_2 \bar{R}_u + \beta_3 Cost_{su} \quad (8)$$

$$\bar{R}_u = \omega_p \left(1 - \left(\frac{MBLE_{OHu}}{MBLE_{REQu}} \right) \right) \quad (9)$$

MSN_u = the current mission assigned to unit u ;

\bar{R}_u = the computed ratio function of supplies on-hand to supplies required for unit u ;

$Cost_{su}$ = the computed cost function for delivering supplies from support unit s to unit u .

Tables 14 and 15 illustrate the descriptive information for a single DSA with three BSA customers. The on-hand and required supply amounts, trucks available at the DSA, the customer missions, etc. are presented in these tables. The priority values are computed using equation (8).

MBLE_{OH}	OHDS	6.0000	MBLE
MBLE_{REQ}	RQDS	6.7500	MBLE
	CYCLE	1.0000	
(Trucks on-hand)_{small}	SmTrks	0.0000	
(Trucks on-hand)_{midsize}	MidTrks	27.0000	
(Trucks on-hand)_{large}	LrgTrks	24.0000	
(Trucks on-hand)_{het}	HetTrks	18.0000	
Small truck capacity	SmCap	0.0046	MBLE
Midsize truck capacity	MidCap	0.0092	MBLE
Large truck capacity	LrgCap	0.0414	MBLE
Het truck capacity	HetCap	0.0735	MBLE
TimeMHE	MHEtime	100.8000	
	MBLE(wt)	544.0000	STONS

Table 14. DSA descriptive information.

	BSA, unit 1	ATK
MSN_u	MBS1	1.0000
$MBLE_{OH}$	OHBS1	1.5000
$MBLE_{REQ}$	RQBS1	3.0000
	RteBS1	1.0000
R_u	Ru1	0.6250
PR_{su}	PriBS1	5.0468
	MsnREQ1	1.5000
	BSA, unit 2	ATK
MSN_u	MBS2	1.0000
$MBLE_{OH}$	OHBS2	1.5000
$MBLE_{REQ}$	RQBS2	3.0000
	RteBS2	2.0000
R_u	Ru2	0.6250
PR_{su}	PriBS2	5.0468
	MsnREQ2	1.5000
	BSA, unit 3	DEF
MSN_u	MBS3	0.8600
$MBLE_{OH}$	OHBS3	1.5000
$MBLE_{REQ}$	RQBS3	3.0000
	RteBS3	3.0000
R_u	Ru3	0.6250
PR_{su}	PriBS3	4.7668
	MsnREQ3	1.5000

Table 15. Customer unit information.

Table 16 presents the cost information used to compute $Cost_{su}$ from equations (13) and (14), from Chapter IV. The same cost information was used for each customer in the spreadsheet model.

E_g	Grnd1	100.0000
E_a	Air1	50.0000
E_o	Obst1	100.0000
β	AlphAir1	0.0025
α	AlphGrd1	0.0036
τ	AlphObs1	0.0003
η	AlphNC1	0.0001
	dsdt1	-0.4376
	Time1	0.2500
s	StdReq	0.5000
$Cost_{su}$	Cost1	0.7812

Table 16. Cost information for a standard convoy along a route.

$$\frac{ds}{dt} = -\alpha(s)(E_g) - \beta(s)(E_a) - \tau(s)(E_o) - \eta(s) \quad (13)$$

$$Cost_{su} = 1 + \left(\frac{ds}{dt} \cdot \frac{t}{cs} \right) \quad (14)$$

The final priority values and proportions for this run of the spreadsheet are presented in Table 17.

Values		
Pr_{s1}	PriBS2	5.0468
Pr_{s2}	PriBS1	5.0468
Pr_{s3}	PriBS3	4.7668
	Sum	14.8605
Proportions		
	ProBS1	0.3396
	ProBS2	0.3396
	ProBS3	0.3208
	Sum	1.0000

Table 17. Priority Values and Priority Proportions.

The logistical feasibility was computed for each run of the spreadsheet model by first calculating the supply allocations according to the methodology presented in Chapter IV using the algorithms under constrained assets to fill requests. The supply assets were apportioned according to the priority proportion of the customer, and filled from the top priority to the bottom. If the customer needed fewer assets than its proportion allotted,

the extra assets remained for the use of lower priority units. The allocations for supplies, MHE time, and trucks are presented in Table 18, along with the final allocation of supplies calculated to be sent to the unit. Note that the allocation of trucks normally provided the minimum constraint for the amount of supplies sent to a unit.

Allocation (Supplies)					
Allocation					
AlocS1	1.5000				
AlocS2	1.5000				
AlocS3	1.5000				
	4.5000				
Allocation (MHEtime)					
Allocation in MBLE		Load Time			
AlocM1	1.2598	34.2331			
AlocM2	1.2598	34.2331			
AlocM3	1.1899	32.3338			
	3.7094	100.8000			
	100.8000				
Round Trips			Allocation in MBLE (Min, Sply, MHE)		
RTrp1	1.0000		SA1	1.2598	
RTrp2	1.0000		SA2	1.2598	
RTrp3	1.0000		SA3	1.1899	
Allocation (Trucks)					
	Small	Mid	Large	Het	Aloc (Trucks)
AlocT1	0.0000	9.0000	8.0000	6.0000	0.8548
AlocT2	0.0000	9.0000	8.0000	6.0000	0.8548
AlocT3	0.0000	9.0000	8.0000	6.0000	0.8548
Allocation in MBLE (Supply, MHE, Trucks)					
	Sply1	0.8548			
	Sply2	0.8548			
	Sply3	0.8548			

Table 18. Allocation of Supply Assets.

The expected loss estimates were calculated using the new parameter for the amount of supplies transported along the route in place of the standard supply request, s. Table 19 provides an example of the expected loss information for one customer unit.

E_g	Grnd1	100.0000
E_a	Air1	50.0000
E_o	Obst1	100.0000
β	AlphAir1	0.0025
α	AlphGrd1	0.0036
τ	AlphObs1	0.0003
η	AlphNC1	0.0001
	dsdt1	-0.4926
	Time1	0.2500
	ExpLoss1	-0.1441

Table 19. Expected loss information for a convoy along a route.

The expected losses and consumption at the customer units were calculated using equation (24), from Chapter IV, and information such as that contained in Table 20.

$$E[TL_{c,t+\delta} | M_{(t+\delta)}] = \sum_{d=1}^{\delta} E[Lr_d | M_{(t+\delta)}] + E[Lc_d | M_{(t+\delta)}] + E[Cc_d | M_{(t+\delta)}]. \quad (24)$$

	GrdU1	100.0000
	AirU1	50.0000
	AlphGrdU	0.0016
	AlphAirU	0.0009
-E[Cc_d]	ConsU1	-0.2297
-E[Lr_d] - E[Lc_d]	dsdtU1	-0.1985
- E[Lr_d] - E[Lc_d] - E[Cc_d]	ExpLU1	-0.4282

Table 20. Expected losses at customer unit information.

Table 21 presents the maximum amount of supplies attainable at the customers, the total expected losses for each customer, the maximum supplies available when the expected losses are subtracted and finally the standard deviations of the Normal distributions used to calculate the logistical feasibility probabilities. The standard deviations were chosen by the author to be 33% of the mean.

Max On-Hand		Total E[Losses]		
MaxU1	2.3548	EL1	-0.5723	
MaxU2	2.3548	EL2	-0.5723	
MaxU3	2.3548	EL3	-0.5723	
Max - E[L] = Mean		Standard Deviation		
Mean1	1.7825	SDev1	0.1908	
Mean2	1.7825	SDev2	0.1908	
Mean3	1.7825	SDev3	0.1908	

Table 21. Expected Loss / On-Hand information.

Table 22 presents the tabular form of the logistical feasibility matrix for this spreadsheet run.

Log Feas Matrix				
	BSA1	ATK	HIGH	
	BSA2	ATK	HIGH	
	BSA3	DEF	HIGH	
	Q=1	Q=2	Q=3	Q=4
Unit 1	0.0000	0.0071	0.4564	0.5365
Unit 2	0.0000	0.0071	0.4564	0.5365
Unit 3	0.0000	0.0071	0.4564	0.5365

Table 22. Logistical Feasibility Matrix.

Tables 23 and 24 provide the final results for the priority values and logistical feasibility matrices for the nine runs of the spreadsheet model, respectively.

Scenario Set 1							
UNIT	MISSION	NEED			NEED		NEED
BSA 1	ATK	HIGH			LOW		LOW
BSA 2	ATK	HIGH			LOW		HIGH
BSA 3	DEF	HIGH			HIGH		HIGH
Priority List			Priority List			Priority List	
	BSA1	5.0468		BSA3	4.7668	BSA2	5.0468
	BSA2	5.0468		BSA2	3.7968	BSA3	4.7668
	BSA3	4.7668		BSA1	3.7968	BSA1	3.7968
	SUM	14.8604		SUM	12.3604	SUM	13.6104
Priority Proportions			Priority Proportion			Priority Proportions	
	BSA1	0.3396		BSA3	0.3857	BSA2	0.3708
	BSA2	0.3396		BSA2	0.3072	BSA3	0.3502
	BSA3	0.3208		BSA1	0.3072	BSA1	0.2790
	SUM	1.0000		SUM	1.0000	SUM	1.0000
Scenario Set 2							
UNIT	MISSION	NEED			NEED		NEED
BSA 1	DEF	HIGH			HIGH		HIGH
BSA 2	ATK	HIGH			LOW		LOW
BSA 3	DEF	HIGH			HIGH		LOW
Priority List			Priority List			Priority List	
	BSA2	5.0468		BSA1	4.7668	BSA1	4.7668
	BSA1	4.7668		BSA3	4.7668	BSA2	3.7968
	BSA3	4.7668		BSA2	3.7968	BSA3	3.5168
	SUM	14.5804		SUM	13.3304	SUM	12.0804
Priority Proportions			Priority Proportion			Priority Proportions	
	BSA2	0.3461		BSA1	0.3576	BSA1	0.3946
	BSA1	0.3269		BSA3	0.3576	BSA2	0.3143
	BSA3	0.3269		BSA2	0.2848	BSA3	0.2911
	SUM	1.0000		SUM	1.0000	SUM	1.0000
Scenario Set 3							
UNIT	MISSION	NEED			NEED		NEED
BSA 1	ATK	HIGH			HIGH		LOW
BSA 2	ATK	HIGH			LOW		LOW
BSA 3	DEF	HIGH			HIGH		HIGH
Priority List			Priority List			Priority List	
	BSA2	5.0468		BSA1	4.1868	BSA3	4.1868
	BSA1	4.1868		BSA3	4.1868	BSA2	3.7968
	BSA3	4.1868		BSA2	3.7968	BSA1	3.0618
	SUM	13.4204		SUM	12.1704	SUM	11.0454
Priority Proportions			Priority Proportion			Priority Proportions	
	BSA2	0.3761		BSA1	0.3440	BSA3	0.3791
	BSA1	0.3120		BSA3	0.3440	BSA2	0.3437
	BSA3	0.3120		BSA2	0.3120	BSA1	0.2772
	SUM	1.0000		SUM	1.0000	SUM	1.0000

Table 23. Priority Value and Proportion Results.

Scenario Set 1					Scenario Set 2				
UNIT	MISSION	NEED			UNIT	MISSION	NEED		
BSA1	ATK	HIGH			BSA1	DEF	HIGH		
BSA2	ATK	HIGH			BSA2	ATK	HIGH		
BSA3	DEF	HIGH			BSA3	DEF	HIGH		
	Q=1	Q=2	Q=3	Q=4		Q=1	Q=2	Q=3	Q=4
Unit 1	0.0000	0.0071	0.4564	0.5365	Unit 1	0.0000	0.0071	0.4564	0.5365
Unit 2	0.0000	0.0071	0.4564	0.5365	Unit 2	0.0000	0.0071	0.4564	0.5365
Unit 3	0.0000	0.0071	0.4564	0.5365	Unit 3	0.0000	0.0071	0.4564	0.5365
UNIT	MISSION	NEED			UNIT	MISSION	NEED		
BSA1	ATK	LOW			BSA1	DEF	HIGH		
BSA2	ATK	LOW			BSA2	ATK	LOW		
BSA3	DEF	HIGH			BSA3	DEF	HIGH		
	Q=1	Q=2	Q=3	Q=4		Q=1	Q=2	Q=3	Q=4
Unit 1	0.0578	0.6564	0.2824	0.0034	Unit 1	0.0000	0.0082	0.4760	0.5159
Unit 2	0.0578	0.6564	0.2824	0.0034	Unit 2	0.0537	0.6291	0.3120	0.0052
Unit 3	0.0000	0.0156	0.6020	0.3824	Unit 3	0.0000	0.0071	0.4555	0.5374
UNIT	MISSION	NEED			UNIT	MISSION	NEED		
BSA1	ATK	LOW			BSA1	DEF	HIGH		
BSA2	ATK	HIGH			BSA2	ATK	LOW		
BSA3	DEF	HIGH			BSA3	DEF	LOW		
	Q=1	Q=2	Q=3	Q=4		Q=1	Q=2	Q=3	Q=4
Unit 1	0.0578	0.6564	0.2824	0.0034	Unit 1	0.0000	0.0414	0.7037	0.2548
Unit 2	0.0000	0.0086	0.5104	0.4811	Unit 2	0.0524	0.6197	0.3219	0.0060
Unit 3	0.0000	0.0074	0.4893	0.5033	Unit 3	0.0524	0.6197	0.3219	0.0060
Scenario Set 3									
UNIT	MISSION	NEED			UNIT	MISSION	NEED		
BSA1	DELAY	HIGH			BSA1	DELAY	HIGH		
BSA2	ATK	HIGH			BSA2	ATK	LOW		
BSA3	DELAY	HIGH			BSA3	DELAY	HIGH		
	Q=1	Q=2	Q=3	Q=4		Q=1	Q=2	Q=3	Q=4
Unit 1	0.0000	0.0217	0.4526	0.5256	Unit 1	0.0001	0.0362	0.5314	0.4323
Unit 2	0.0000	0.0148	0.5710	0.4142	Unit 2	0.0538	0.6298	0.3113	0.0052
Unit 3	0.0001	0.0327	0.5175	0.4498	Unit 3	0.0001	0.0362	0.5314	0.4323
UNIT	MISSION	NEED			UNIT	MISSION	NEED		
BSA1	DELAY	LOW							
BSA2	ATK	LOW							
BSA3	DELAY	HIGH							
	Q=1	Q=2	Q=3	Q=4					
Unit 1	0.0350	0.4536	0.4717	0.0397					
Unit 2	0.0578	0.6564	0.2824	0.0034					
Unit 3	0.0002	0.0703	0.6458	0.2837					

Table 24. Logistical Feasibility Matrices.

LIST OF REFERENCES

1. Department of Defense, Dictionary of Military and Associated Terms, Joint Publication 1-02, Operational Plans and Interoperability Directorate, Washington, DC, 29 March 1994.
2. Combined Arms and Services Staff School, "Fundamentals of Tactical Sustainment," Fort Leavenworth, Kansas, March 1989.
3. Brouillette, G., "Modeling Joint Theater Level operations in the Early Entry Theater Level Model", Master's Thesis, Naval Postgraduate School, Monterey, California, September 1994.
4. Youngren, M. A., "The Joint Warfare Analysis Experimental Prototype (JWAEP), version 1.0: User Documentation, Draft," Naval Postgraduate School, Monterey, California, 21 November 1994.
5. Army Concepts Analysis Agency, *Concepts Evaluation Model VI (CEM VI): Volume I - Technical Description*, Bethesda, Maryland, 1987.
6. Army Concepts Analysis Agency, *Concepts Evaluation Model VI (CEM VII): Volume II - User's Handbook*, Bethesda, Maryland, 1991.
7. Parry, S. H., "Report 2: TACWAR Evaluation," Naval Postgraduate School, Monterey, California, 30 SEP 91.
8. Combat Analysis Group, United States Central Command, *TACWAR Logistics Analyst Guide*, MacDill Air Force Base, Florida, 1991.
9. Calkins, R., "Vector-In-Commander (VIC), Executive Summary", TRADOC Analysis Center, Fort Leavenworth, Kansas, (Date Unknown).
10. TRADOC Analysis Center, "VIC User's Guide", Fort Leavenworth, Kansas, (Date Unknown).
11. Interview with LTC Joseph Manzo, USA, U.S. Army Concepts Analysis Agency, and author, November 1994.
12. Air Force Studies and Analyses Agency, *THUNDER Analyst's Manual, Version 6.1*, CACI Products Company, Arlington, Virginia, MAY 1994.

13. Department of the Army, Field Manual 101-10-1/1 "Staff Officer's Field Manual Organizational, Technical, Logistical Data (Volume 1)", Headquarters, Department of the Army, Washington, D.C., October 1987.
14. Department of the Army, Field Manual 101-10-1/2 "Staff Officer's Field Manual Organizational, Technical, Logistical Data Planning Factors (Volume 2)", Headquarters, Department of the Army, Washington, D.C., October 1987.
15. Youngren, M. A., "Aggregated Strength Variables for the JWAEP Model," Naval Postgraduate School, Monterey, California, January 1993.
16. Hartman, J. K., Parry, S. H., Caldwell, W. J., "Airland Combat Models II, Aggregated Combat Modeling," Naval Postgraduate School, Monterey, California, 7 DEC 92.
17. Hartman, J. K., Parry, S. H., Caldwell, W. J., "Airland Combat Models I, High Resolution Combat Modeling," Naval Postgraduate School, Monterey, California, 8 DEC 92.
18. Law, A. M., Kelton, W. D., *Simulation Modeling and Analysis*, McGraw-Hill, New York, New York, 1991.
19. Mendenhall, W., Wackerly, D., Scheaffer, R., *Mathematical Statistics with Applications*, 4th Edition, Duxbury Press, Belmont, California, 1990.
20. Winston, W., *Operations Research: Applications and Algorithms*, 2nd Edition, Duxbury Press, Belmont, California, 1991.
21. Youngren, M. A., "Future Theater Level Model (FTLM) Summary of Model Concept, Consolidated Rough Draft," CFAD, J-8, The Joint Staff, AUG 93.

INITIAL DISTRIBUTION LIST

- | | | |
|----|---|----|
| 1. | Defense Technical Information Center
Cameron Station
Alexandria, Virginia 22304-6145 | 2 |
| 2. | Library, Code 013
Naval Postgraduate School
Monterey, California 93943-5101 | 2 |
| 3. | Professor Samuel Parry
Code OR/PY
Naval Postgraduate School
Monterey, California 93943-5002 | 10 |
| 4. | LTC Mark Youngren
Code OR/YM
Naval Postgraduate School
Monterey, California 93943-5002 | 10 |
| 5. | Director, US Army TRADOC Analysis Center
ATTN: ATRC-FA
Ft. Leavenworth, Kansas 66027 | 1 |
| 6. | Defense Logistic Studies Information Exchange
U.S. Army Logistics Management College
Ft. Lee, Virginia 23801-6043 | 1 |
| 7. | CPT Thomas J. Wilk, USA
42 Church Rd.
Bedford, NH 03310 | 2 |
| 8. | Deputy Director for Technical Operations, J-8
8000 The Joint Staff
Washington, DC 20318-8000 | 1 |
| 9. | Chief, Warfighting Analysis Division, J-8
8000 The Joint Staff
Washington, DC 20318-8000 | 1 |

10. Director, US Army TRADOC Analysis Center
ATTN: ATRC (Mr. Bauman)
Ft. Leavenworth, KS 66027-5200 1
11. Director, US Army TRADOC Analysis Center - Monterey
ATTN: ATRC-RDM (LTC Wood)
Monterey, CA 93943 1
12. Air Force Institute of Technology
AFIT/ENS
2950 P St.
Wright-Patterson, AFB OH 45433 1
13. US Army Concepts Analysis Agency
8000 The Joint StafATTN: Mr. Chandlerf
8120 Woodmont Ave.
Bethesda, MD 20814-2797 1
14. US Army War College
Center for Strategic Leadership
ATTN: COL Wilkes
Bldg 650
Carlisle, PA 17013-5050 1
15. The Joint Staff-J6AC
ATTN: John Garstka
6000 The Joint Staff
Washington, DC 20318-6000 1
16. Center for Naval Warfare Studies
Naval War College
Newport, RI 02841 1
17. US Army Missile Command
ATTN: AMSMI-RD-AC (Dr. Fowler)
Redstone Arsenal, AL 35898-5242 1
18. US Army Materiel Systems Analysis Activity
ATTN: Mr. Bill Clay
Aberdeen Proving Ground, MD 21005-5001 1