

REPORT DOCUMENTATION PAGE

Form Approved
OMB No. 0704-0188

Public reporting burden for this collection of information is estimated to average 1 hour per response, including the time for reviewing instructions, searching existing data sources, gathering and maintaining the data needed, and completing and reviewing the collection of information. Send comments regarding this burden estimate or any other aspect of this collection of information, including suggestions for reducing this burden, to Washington Headquarters Services, Directorate for Information Operations and Reports, 1215 Jefferson Davis Highway, Suite 1204, Arlington, VA 22202-4302, and to the Office of Management and Budget, Paperwork Reduction Project (0704-0188), Washington, DC 20503.

1. AGENCY USE ONLY (Leave blank)	2. REPORT DATE <p style="text-align: center;">March 1996</p>	3. REPORT TYPE AND DATES COVERED <p style="text-align: center;">Professional Paper</p>
4. TITLE AND SUBTITLE <p style="text-align: center;">LASER-BASED 3-D VOLUMETRIC DISPLAY SYSTEM (THE IMPROVED SECOND GENERATION)</p>		5. FUNDING NUMBERS <p style="text-align: center;">PR: CDB0 PE: 0602122N WU: DN303196</p>
6. AUTHOR(S) <p style="text-align: center;">P. Soltan, J. Trias, W. Dahlke, M. Lasher, and M. McDonald</p>		8. PERFORMING ORGANIZATION REPORT NUMBER
7. PERFORMING ORGANIZATION NAME(S) AND ADDRESS(ES) <p style="text-align: center;">Naval Command, Control and Ocean Surveillance Center (NCCOSC) RDT&E Division San Diego, CA 92152-5001</p>		
9. SPONSORING/MONITORING AGENCY NAME(S) AND ADDRESS(ES) <p style="text-align: center;">Office of Naval Research 800 North Quincy Street Arlington, VA 22217-5000</p>		10. SPONSORING/MONITORING AGENCY REPORT NUMBER
11. SUPPLEMENTARY NOTES		
12a. DISTRIBUTION/AVAILABILITY STATEMENT <p style="text-align: center;">Approved for public release; distribution is unlimited.</p>		12b. DISTRIBUTION CODE

13. ABSTRACT (*Maximum 200 words*)

NRaD, the RDT&E Division of the Naval Command, Control and Ocean Surveillance Center (NCCOSC), has developed and improved its second-generation device for displaying data, information, and scenes in a three-dimensional volume of image space. The device incorporates a 36-inch diameter double helix that spins at approximately 10 revolutions per second, providing a means to address a cylindrical volume. Under computer control, a laser beam is directed to illuminate certain discrete volume points (voxels) on the helix needed to create a scene. The laser light scatters from the surface of the helix, so, to the observer, each voxel appears to emanate from specific points in space. Each point has x-y coordinates determined by the position of the laser beam and a z coordinate determined by the height of the point on the helical surface. Any point within the cylindrical image volume can be computer-addressed to appropriately synchronize the laser beam, the Acousto-Optic (AO) Scanner, and the phase of the helix.

Using a novel Acousto-Optic (AO) Random-Access Scanner, up to 40,000 laser-generated voxels refreshed at 20 Hz per color are projected onto the reflective surface of the rotating helix. (This is about 10 times more than the current state of the art.) The higher resolution allows improved color images, updated in real-time, for group viewing with the naked eye.

19960404 088

Published in *American Society of Naval Engineering*, April 1995.

14. SUBJECT TERMS <p style="text-align: center;">Mission Area: 3-D Technology 3-D Acoustic-Optic (AO) Random-Access Scanner 3-D Volumetric Display Laser Double Helix</p>			15. NUMBER OF PAGES
17. SECURITY CLASSIFICATION OF REPORT <p style="text-align: center;">UNCLASSIFIED</p>			16. PRICE CODE
18. SECURITY CLASSIFICATION OF THIS PAGE <p style="text-align: center;">UNCLASSIFIED</p>	19. SECURITY CLASSIFICATION OF ABSTRACT <p style="text-align: center;">UNCLASSIFIED</p>	20. LIMITATION OF ABSTRACT <p style="text-align: center;">SAME AS REPORT</p>	

UNCLASSIFIED

21a. NAME OF RESPONSIBLE INDIVIDUAL P. Soltan	21b. TELEPHONE (include Area Code) (619) 553-3584	21c. OFFICE SYMBOL Code 44215



**LASER-BASED 3-D VOLUMETRIC DISPLAY SYSTEM
(THE IMPROVED SECOND GENERATION)**

Parviz Soltan, John Trias, Weldon Dahlke,
Mark Lasher, Malvyn McDonald

Simulation and Human Systems Technology Division

Point of Contact:

Parviz Soltan
NRaD, Code 44215
Phone 619-553-3584

January 5, 1995

Approved for public release; distribution is unlimited.

ABSTRACT

NRaD, the RDT&E Division of the Naval Command, Control and Ocean Surveillance Center (NCCOSC), has developed and improved its second-generation device for displaying data, information, and scenes in a three-dimensional volume of image space. The device incorporates a 36-inch diameter double helix that spins at approximately 10 revolutions per second, providing a means to address a cylindrical volume. Under computer control, a laser beam is directed to illuminate certain discrete volume points (voxels) on the helix needed to create a scene. The laser light scatters from the surface of the helix, so, to the observer, each voxel appears to emanate from specific points in space. Each point has x-y coordinates determined by the position of the laser beam and a z coordinate determined by the height of the point on the helical surface. Any point within the cylindrical image volume can be computer-addressed to appropriately synchronize the laser beam, the Acousto-Optic (AO) Scanner, and the phase of the helix. See figures 1 and 8.

Using a novel Acousto-Optic (AO) Random-Access Scanner, up to 40 thousand laser-generated voxels refreshed at 20 Hz per color are projected onto the reflective surface of the rotating helix. (This is about 10 times more than the current state of the art.) The higher resolution allows improved color images, updated in real-time, for group viewing with the naked eye (see the optical head in figure 8).

PATENT STATEMENT

This technology is covered by one or more U.S. government-owned patents, patent applications and/or invention disclosures. Parties interested in licensing this technology may direct inquiries to:

Harvey Fendelman, Legal Counsel for Patents, Code 0012
NCCOSC
53560 Hull Street
San Diego, CA 92152-5765
(619) 553-3001

ACKNOWLEDGMENTS

The authors wish to express their appreciation to Mr. W.J. King of the Office of Naval Research (ONR), to Dr. Tice F. Deyoung of the Advanced Research Project Agency (ARPA), to Mr. Richard T. Shearer, Executive Director, and to Dr. Robert C. Kolb, Head, Command and Control C² Department, Code 40, for their support of the program. Credit goes to Messrs. Robert Belfatto and Frank Sanzone of NEOS Technologies, Melbourne, Florida, who, under Navy contract, developed the novel "AO" device.

INTRODUCTION

BACKGROUND

An ideal 3-D volumetric display enables several observers to view a volume of image space from any position with the naked eye. It provides, in real-time, an actual physical volume of images having height, depth, and width.

The concept of laser-generated 3-D volumetric displays was suggested by Rudiger Hartwig of the University of Stuttgart in the early 1980s. This concept involved using a laser beam to illuminate the surface of a rotating helix. The feasibility of such a system, however, was demonstrated by Don Williams of Texas Instruments (TI) at the 1988 Society for Information Display (SID) International Symposium in Anaheim, California. Williams showed a laser beam generating simple 3-D geometric figures in a volume defined by a rotating disk.

During the 1980s, another volumetric (multiplanar) technology, called the "Space-Graph 3-D Display System," was developed by Lawrence Sher of Bolt, Beranek & Newman (BBN). This CRT-based technology uses a vibrating flexible mirror to provide the third dimension for images reflected off a CRT. The maximum volume generated by the Space-Graph 3-D Display System was 25cm by 25cm by 25cm, with a resolution of 24k points in each stroke, at a 30Hz refresh rate.

In early 1990, an NCCOSC RDT&E Division team in San Diego, California, recognized the dual (military/civilian) application of this real-time laser-generated 3-D display. With support from the Navy and ARPA, further research and development enabled the construction of the first-generation 3-D volumetric display, comprising a 13-inch diameter double-helix containing a 125 cubic inch display volume with a maximum of 4,000 displayable voxels per color refreshed at 20 Hz (see figure 1).

Why 3-D Volumetric Imaging?

What motivates this intense interest in developing a true three-dimensional display? The human visual system applies both psychological and physiological depth cues to create three-dimensional scenes. To form three-dimensional (3-D) images on two-dimensional (2-D) displays such as a cathode ray tube (CRT), manufacturers must use electronic, optic and software tricks to create the 3-D illusion. For example, CRT-based computer graphics rely on "rendering" 3-D scenes in 2-D, using primarily psychological depth cues such as the following:

- Linear Perspective (distant objects appear smaller)
- Shading and Shadowing (near vs distant objects)
- Texture Gradient (distant objects have less detail)
- Color (distant objects are darker)
- Aerial Perspective (distant objects appear cloudy)
- Occlusion (near objects hide distant objects).

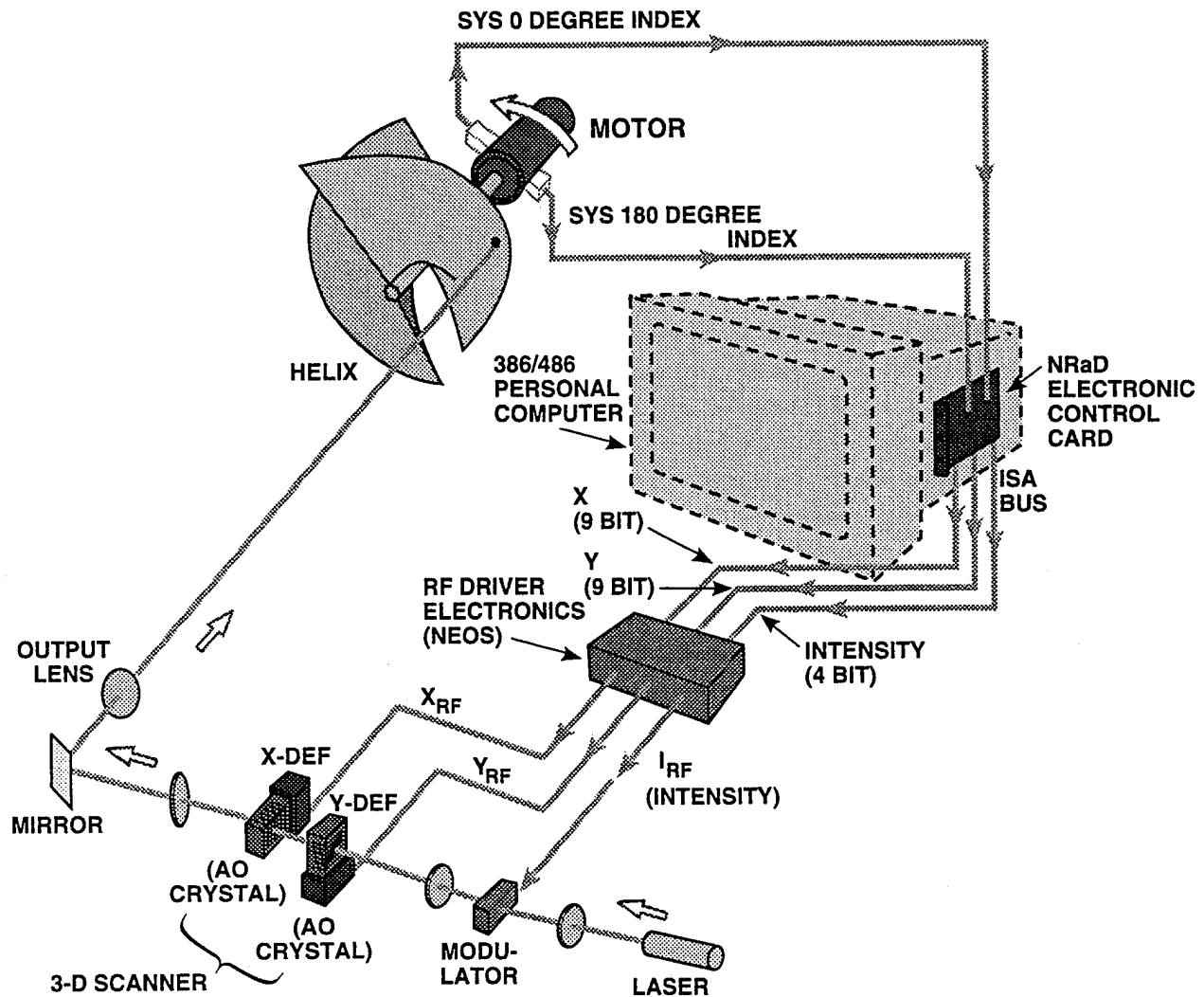

Figure 1. Simplified, laser-based, 3-D 4k voxels per color Volumetric Display (First generation).

Computer calculation of these psychological depth cues creates illusory 3-D images and scenes on 2-D display devices. They lack important physiological depth cues, especially motion parallax (limited directional viewing). Thus, some important missing physiological depth cues in computer generated 3-D images are:

- Motion Parallax (image changes due to the motion of the observer in x, y, and z planes)
- Accommodation (change in focal length of the eye lens)
- Convergence (inward rotation of the eyes)
- Binocular Disparity (difference between left- and right-eye images).

3-D volumetric displays use both psychological and physiological depth cues. Image points are physically formed in all three spatial dimensions for fast presentation of 3-D volumes (as well as surfaces). Thus, these 3-D images can be viewed from any arbitrary direction (good motion paral-

lax). Actually, they approach the goal of providing depth rather than depth cues. Here, because image points are physically formed in all three spatial dimensions, a 2-D point pixel becomes a volume point (voxel) with x, y, and z coordinates consequently providing real-time 3-D volume images for group viewing with the naked eye and with no restrictions on head movement.

How the 3-D Volumetric Images are Formed

A simplified data flow diagram of a helix-based 3-D volumetric display is presented in figures 1 and 8. The key to the system's volumetric imaging capabilities is in the synchronization of the helix rotation with the data output from the computer, while, at the same time, recognizing the fundamental limitations of the 2-D optical scanner being used. Images are formed by first translating raw xyz-coordinates into a form which maps the z-axis from the spatial domain to a temporal domain in computer memory. In other words, the height of a point on the z-axis is determined by its location in memory. When the computer receives a synchronization pulse from one of the sensors on the hub of the helix, x-y coordinate pairs are sent to the optical scanner in the appropriate sequence to create voxels with the desired z coordinates. Any point in the display volume may be addressed in this way.

The points of light reflected from the helix surface constitute a true volumetric image composed of voxels in real space. The major limitations of this first generation 3-D volumetric system were the small size of the image volume (125 cu. in.); the relatively small number of displayable voxels (4k per color); and the inherent system and viewability restrictions of front projection to a reflective, opaque helical surface. The feasibility of this 3-D technology and the technical results of the first generation were reported in 1992. (See reference 4.)

Objective for Second-Generation Prototype

Work on the second-generation system started in mid-1992 with the following technical objectives:

- a. Develop an advanced Acousto-Optic (AO) Random Scanner that can display up to 40k voxels per color with 256 by 256 x and y resolution and 4095 by 4095 addressability per voxel, at a refresh rate of 20 frame/sec.
- b. Develop an electronic control card, the Volumetric #2 Electronic card, for a PC 386/486 Computer to make the 3-D display refresh operation independent of the computer speed. The Volumetric #2 Electronic card can store up to 65k voxels per color. Once the initial image is loaded into the card's memory from the computer, the image can be read out at the display's refresh rate.
- c. Develop a 36-inch diameter by 18-inch-high double helix for the display surface. This would correct the mechanical imbalance and vibration of the single helix, proposed earlier by Hartwig, and also lower the noise at the required rotational speed.
- d. Use multiple laser sources and scanners to provide full-color 3-D images; up to 120k voxels for 3 colors.

- e. Develop or procure appropriate computer software to direct the laser beam(s) to generate mono/color 3-D images in real-time for group viewing with the naked eye.
- f. Show practical 3-D applications for military, medical, and commercial use.

PROGRESS

Since mid-1992, with continuing development of the second-generation 3-D technology, the NRaD team has made technical progress in the important areas described below.

A Noise-Free 36-Inch Diameter by 18-Inch-High Helix (Second Generation)

This new helix features a 36-inch diameter, 18-inch high double helix that displaces a potential cylindrical imaging volume of 10 cubic feet. An addressable image volume 10" x 10" x 15" is presently constrained by the current scanner optics and the occlusions produced by the reflective double helix. Other optical designs can use more of the 10 cubic feet of imaging volume, but require other system tradeoffs. Laser signals are projected onto the moving display surface from overhead allowing "walk around" viewing. A system of ceiling-mounted mirrors folds the laser signal and places it in a vertical attitude. The double helix operates at a design speed of 600 rpm, with minimal noise and vibration. Its design minimizes weight and aerodynamic drag, maximizes structural stiffness, and places particular emphasis on dynamically balancing its rotating components. The helical display (figure 2) is shown expanded into its major components which are: the double helix, rotor housing, bearing and support structure, mechanical drive system, and the angular position sensor.

The double helix fabricated from injection-molded polystyrene plastic, is inherently free of low-frequency vibration by virtue of its unique shape and light weight. The axisymmetry of its double-helix contour sustains an equilibrium of centrifugally-induced forces, and its continuous curvature adds bending stiffness to the structure. The new helical-reflector blade is assembled from eighteen 1-inch-high segments, vertically stacked and bonded together. The blade has a uniform thickness of 2mm, except for a 1/2-inch diameter cylinder (concentric with its vertical axis) that houses a center pin, used to align the plastic segments during assembly and to provide for centering the helix in its housing. The upper surface of the helix is treated with an opaque white finish to enhance reflectivity and light diffusion. The pin and the helix weigh 5 pounds.

The helix is fully enclosed in a transparent cylindrical housing that rotates with it. This housing supports the helix around its entire perimeter and shelters it from contact with nonrotating objects. The housing, mounted on a circular turntable at the top of a 2-inch steel shaft, rotates the volume of entrained air, preventing any drag load on the helix. A shaft-mounted drive pulley and encode disk complete the rotor assembly which is designed for a high first-critical speed (a natural frequency greater than 33Hz) and is dynamically balanced to assure smooth performance. Its total weight is 125 pounds.

The rotor shaft is supported by a pair of self-aligning cartridge bearings. Close-tolerance fits at the bearing interface and a rigid support structure isolates the rotor from drive-component vibrations and assures quiet operation. The shaft is driven via a timing belt by a 1/2-horsepower dc motor. The angular position of the helix is determined by a pair of optical sensors that monitor a trigger disk on the base of the shaft.

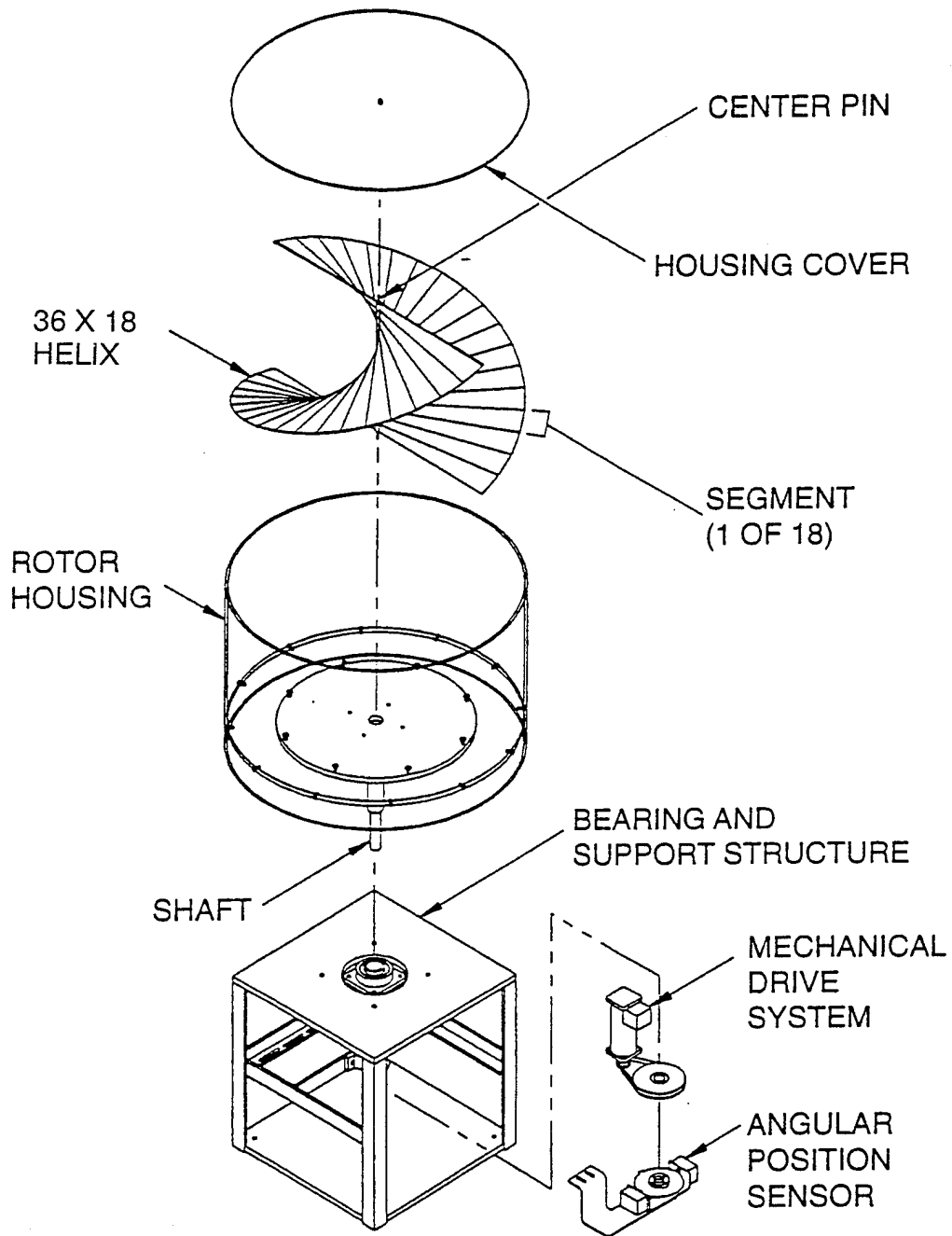

Figure 2. Major components of Helical Display.

Second Generation Acousto-Optic (AO) Laser Scanner

Random access scanning is the most practical approach to efficiently address the display volume. However, it is the major bottleneck to increasing the number of displayable voxels, even with the speed of acousto-optic scanning. The problem stems from the finite time it takes for the acoustic wave to travel across the laser beam and achieve 100% deflection. This is known as the "access time", or "fill time." The random access scanning mode requires that during this time the laser beam must be blanked out with a modulator to avoid smearing in the image due to multiple frequencies being present in the beam deflection path. One must wait for several microseconds for each deflector (x and y) to be loaded with the desired frequencies and then turn on the modulator for the specified "on-time." Because of the fixed image refresh rate (20 Hz) the voxel on-time decreases nonuniformly as the number of voxels is increased. As a result, the overall light level from an image also decreases as the number of voxels increases. The easiest way to increase the number of voxels and to avoid image intensity problems is to couple several scanners together in parallel. A four-channel 4k voxel system was built by NEOS Technologies, Inc., of Melbourne, Florida. It comprises four single-channel scanners, packed into a single box, as shown in figure 3. A lower voxel-access time, from 10 μ sec to 5 μ sec, was achieved by reducing the optical-beam diameter in the AO deflectors from 6mm to 3mm. This doubled the number of displayable voxels in each of the four channels. Each channel can display up to 10k voxels per frame for a total of 40k voxels for four channels at a 20Hz refresh rate.

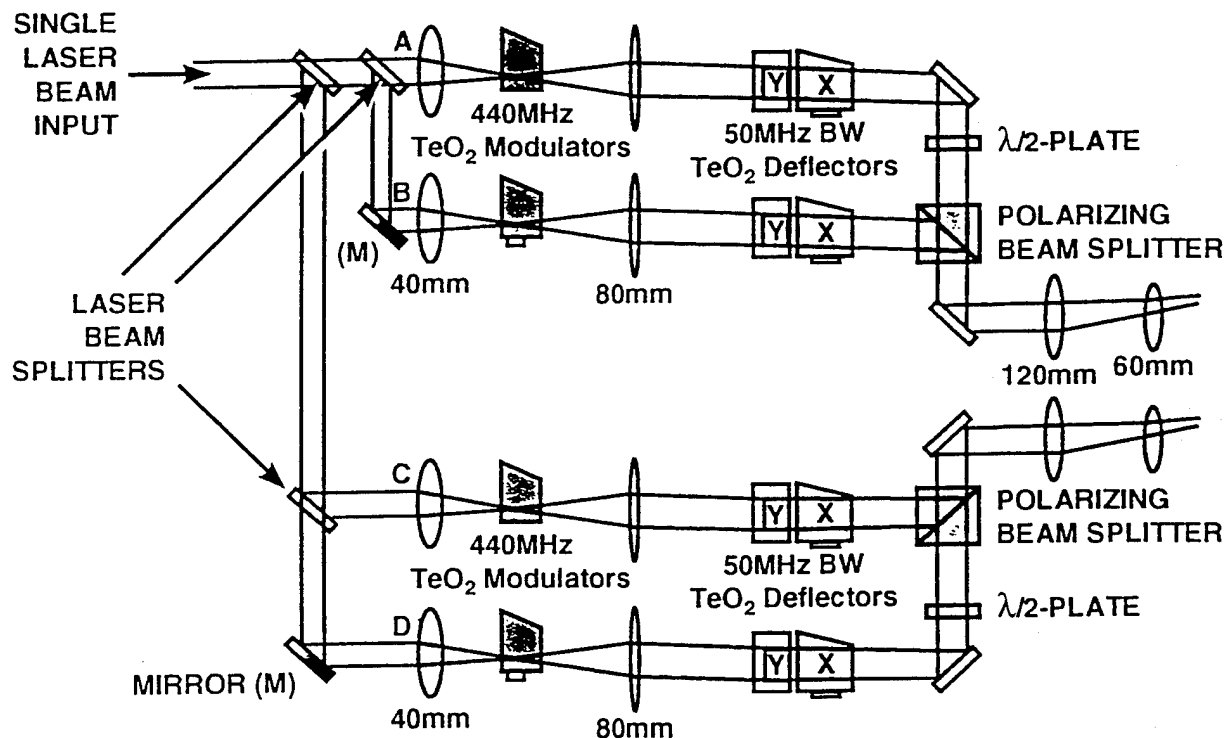

Figure 3. Four-channel parallel processing technique producing 40,000 voxels per color at 20 Hz refresh rate

In figure 3, the single-laser input to the scanner (green, for example) is split four ways by beam splitters (channels A, B, C, and D). Each beam is then focused into a 440MHz Tellurium Dioxide (TeO_2) AO modulator. From there, the beams are recollimated to a diameter of 3mm and sent to the x and y (TeO_2) AO deflectors. The deflectors are swept from 75 to 125 MHz in 5 μ sec to achieve a resolution or time-bandwidth product of 250. To optimize the polarization properties of the scanner, the polarization of the light entering each deflector must be parallel to the direction of the acoustic wave. Vertical polarization is maintained at the input beam to the scanner, thus avoiding use of any wave plates to correct the incoming polarization.

The deflector outputs from two channels (A and B) are combined using a half-wave plate and a polarizing beam splitter. Channels C and D are handled the same way. This assures that all four channels may be overlapped anywhere in the helix. The two outputs are then projected downward onto the helix, using the final output projection lens pair. These lenses also increase the angular magnification of the scanner by a factor of about 2.5. This helps to reduce the required throw distance between the scanner and helix, while maintaining a reasonable spot size. Figure 4 shows, schematically, the four-channel acousto-optic random-access scanner integrated with its electronics package and 36-inch diameter helix. An argon ion gas laser is used as the light source for the system. An input laser, up to 1W, powers the scanner, without damaging the optics. The optics were designed to accept a single-mode laser beam with a diameter of 1.6mm (applied at the input to the scanner) to achieve the desired spot size throughout the rest of the system.

The Second-Generation Electronic Card

Control of the laser beam position, intensity, and timing at the helix surface is provided by a custom computer interface card (Volumetric #2) that enables sending high speed data to the scanner electronics independent of the speed of the host computer (see figure 8). This card is a 10-layered printed circuit control board designed to fit into a standard PC computer-expansion slot (IBM AT or Industry Standard Architecture [ISA]). The board has a total of 448 surface-mount and discrete components. Some of the card's major functions are as follows:

- a. A dual-port RAM memory that holds up to 65,536 32-bit wide words. Each word defines a point that has 12 bits for x, 12 bits for y, and 8 bits for intensity. Image data are loaded into port A of the dual-port RAM at the computer's rate and are read out of port B at the display's refresh rate. The 12 bits of x and y are read from port B of the dual-port RAM and are then sent to the scanner interface board. The NEOS board drives separate x and y RF synthesizers for the laser-deflection circuitry. The 12 bits of x and 12 bits of y allow an addressability of 4096 by 4096, while the AO scanner was designed with a resolution of 250 by 250. To correct misalignment and color registration, extra addressability is available in x and y. This allows the computer to fine-adjust the deflection position of the laser beams for each of the four channels (A, B, C, and D).
- b. A computer-controlled voltage (E-motor, 0 to +10 V) controls the speed of the helix motor.
- c. Special circuitry accurately determines the helix shaft's actual speed to within 6.4 μ sec by counting 156.25-kHz clock pulses for a full revolution of the shaft.

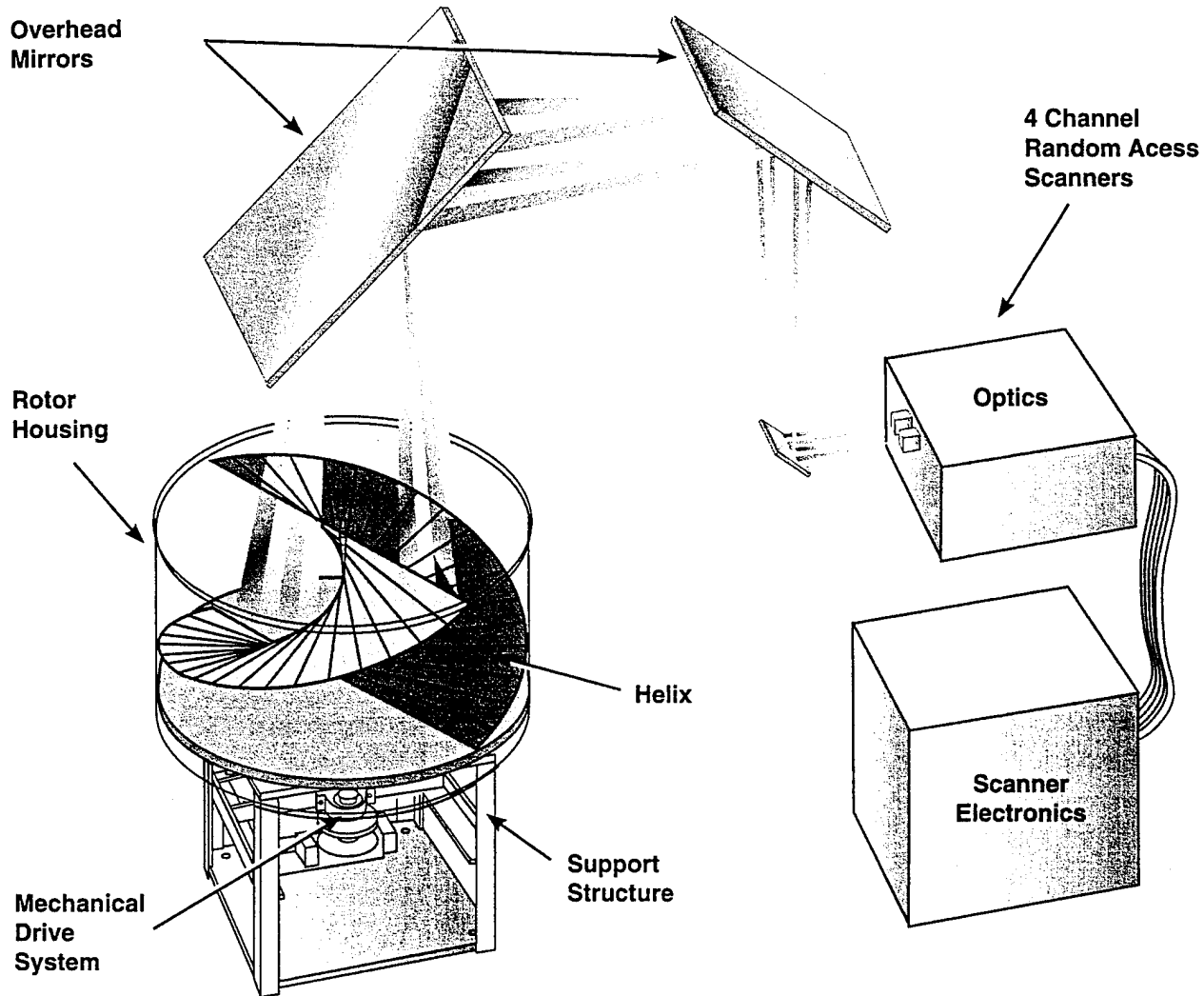

Figure 4. Four-channel AO scanner integrated with the electronics package and 36-inch diameter helix.

- d. Multiboard synchronized circuitry synchronizes additional volumetric cards for color in a single computer or multiple computers to within the master board's clock period of $1/(20 \text{ MHz})$ or 50 nsec.
- e. The video-intensity signal is sent as an 8-bit TTL digital signal to the electronics, where it is converted to a suitable amplitude-modulated RF signal (440MHz), for the AO modulator (see figure 8, Optical Head).

Advantages of Dual-Port Memory

The dual-port memory allows the port-B readout timing of each addressed point to be *independent* of the computer-software execution instruction flow; such as adding or deleting instructions, processing an interrupt, accessing the disk, etc.

Once the dual-port RAM has been loaded through port A with image points, the common-memory image is continuously read out through port B. This is done at the designated refresh rate without using the computer or any ISA bus bandwidth.

System Timing and Clock Functions

In figure 5, the upper three lines show the Clock, Index A, and Data Sequence from the Volumetric #2 Electronic card. Index A is active when channel A data are valid from the computer, and channels B, C, and D data follow in sequence, separated by clock periods.

Channel A data are latched into the A register in the NEOS electronics and held for four-clocks before they are updated. Channel B data are latched one-clock later into the B register in the NEOS electronics and held for four-clocks before being updated. Channels C and D operate similarly, with each latched one-clock later. As described earlier, the finite fill time of the AO deflectors requires that the laser beam intensity must be blanked whenever a voxel's position is changed. This can be seen in the timing diagram in figure 5.

To limit light-beam smearing between two image points, the video is normally blanked during the fill time.

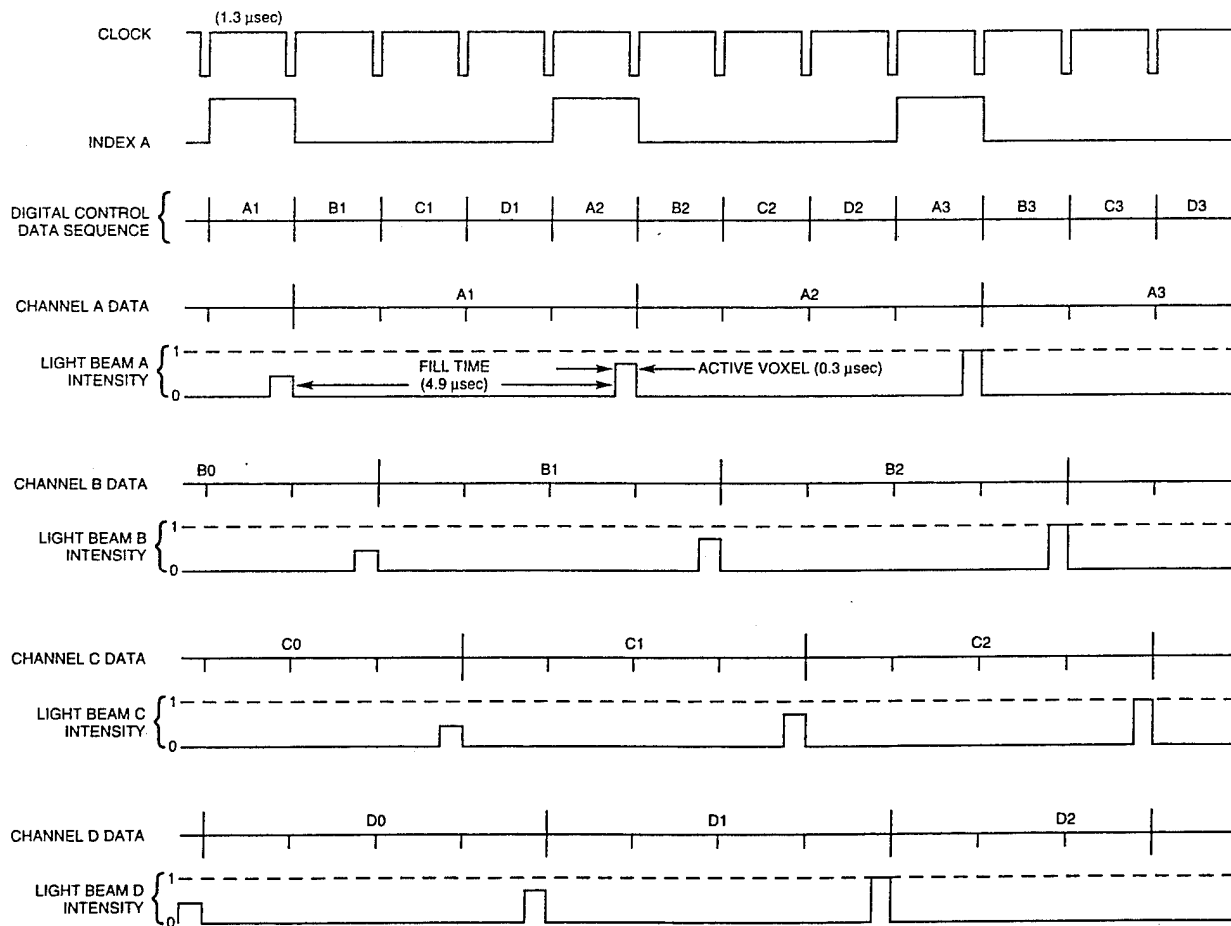

Figure 5. System timing and clock functions.

The TeO₂ slow-shear deflection crystals currently being used have a fill time of 4.9 μsec. The active video intensity of any channel is 4-clock periods, minus the fill time. All four channels are independent and project beams in parallel.

NEW FEATURES AND SYSTEM IMPROVEMENTS

Translucent Helix

To make the system transportable, the development of a translucent helix was proposed. In this concept, the laser signal is projected onto a translucent plastic helix from below. The light is diffused as it passes through the plastic medium making the image voxels visible from above and below the helix. This rear-projection approach eliminates the unwieldy overhead mirrors from the design and allows the lasers, scanners, optics, and the helix to be packaged together as a single mobile unit. Ideally, the laser light reflected from the bottom surface of the helix material and transmitted through its top surface have equal intensity. This is due to the light-diffusing characteristics of the helix material. Balancing the intensity minimizes the discontinuity in image brightness that is otherwise apparent where the viewing angle crosses the plane of the helical blades.

To test the feasibility of this concept and the performance of selected translucent materials, a 12-inch diameter, 6-inch-high helix was fabricated. Tests conducted on a number of the materials being considered showed their light-diffusing characteristics to be influenced primarily by changes in material filler concentration and material thickness. Image blooming, that is, internal reflections that adversely effect image resolution, was found to increase with material thickness. The material selected for initial testing was 0.020-inch-thick high-impact polystyrene. The plastic was vacuum formed to make two identical blades, each representing half of the 12-inch helix. The two blades were bonded together along the central axis of the helix and mounted in a closed cylindrical housing. The transparent acrylic housing is supported by a 1-inch diameter, 2.5-inch-long vertical shaft extension and directly driven by a 1/10-hp dc motor. Two mirrors, positioned on opposite sides of the shaft, fold the projected laser signal upward into the display volume. The feasibility of a translucent helix was demonstrated in the laboratory with a 12-inch model. Improvements to its design and performance are currently being developed. In addition, plans have been made to incorporate this technology into a full-size transportable system.

Green Scanner Improvements

In addition to retrofitting with improved mounts for the acoustic-optics and beamsplitters, new lenses were installed in the green scanner to achieve a more circular output beam. The optimum focused spot diameter for the 440MHz modulators is around 35 microns. Producing this diameter at the modulator required reducing the scanner input beam diameter to 0.8mm. The increased spot size at the modulator required a longer focal length lens (160mm) to produce the 3.2mm diameter beam necessary for the desired deflector operation.

New Red Scanner

Another 4-channel, 40k voxel scanner, specifically designed for producing red images, was installed. It is being used with the green scanner to conduct experiments in producing color images

on the helix. A krypton argon ion laser, operating at the 647nm wavelength, is used as its source. Dichroic mirrors are used to combine the images from the two scanners, see figure 6.

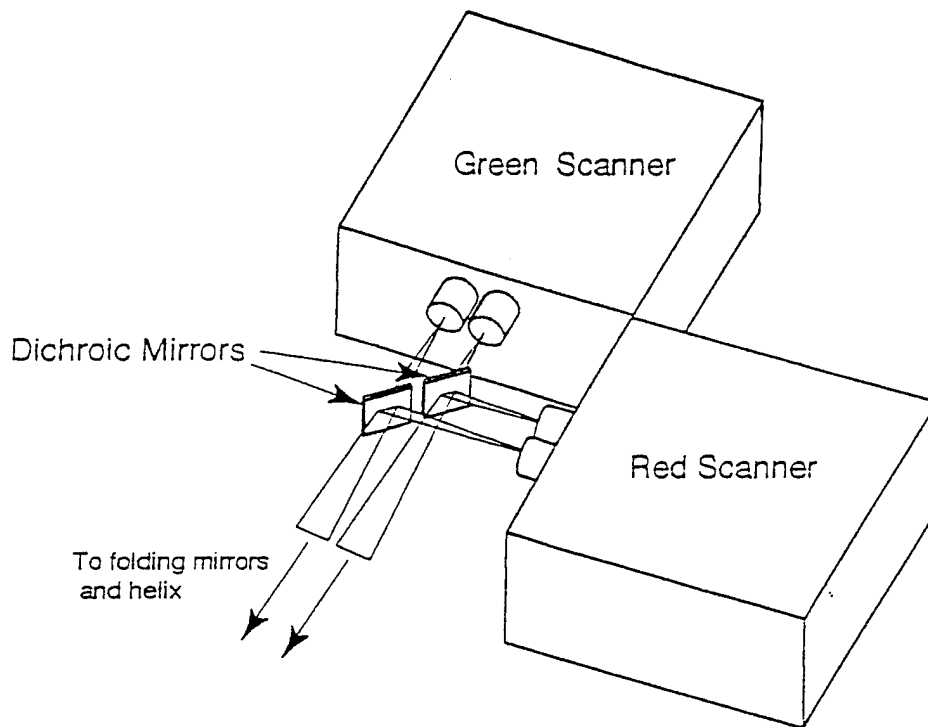

Figure 6. Color combining of red and green scanners using Dichroic filters.

The angular deflection of the AO crystals increases with increasing optical wavelength. To compensate for this effect, the acoustic center frequency of the red scanner was reduced from 100MHz to

75MHz, while keeping the same 50MHz bandwidth. Computer control of the frequency synthesizers allows the tuning of the final image size.

Different acousto-optic (AO) modulators were used to increase efficiency, as well as to lower costs. Their lower frequency means that the deflection angle is reduced. The combination of low deflection angle and the requirement of a circular output beam implies the use of longer focal length optics, leading to an overall increase in the scanner length of 10 inches. Another improvement in beam quality was obtained by using larger TeO_2 crystals for the deflectors. The larger acoustic field associated with these crystals resulted in a more uniform gaussian spot at the image plane.

Zoom Lenses and Color Combining

Since the scan angles of the green and red scanners are only approximately the same, compensation must be made to achieve complete convergence within the entire image volume. Standard 35mm camera zoom lenses were installed to provide independent control of the image size. Dichroic filters (red reflecting/green transmitting) were used to combine the red and green images.

System Performance

The addressable volume inside the 36-inch diameter helix is currently set by the optics of the system at 10" x 10" x 15". The spot size of a single voxel is 1.7mm.

The overall optical efficiency, as measured from the input of the scanner to the helix surface, is 10% for the green scanner and 15% for the red scanner. With an input power of 200mW, total image intensity of all four channels is around 20-30mW. It should be emphasized that these measurements were made with the scanner displaying one point continuously. No blanking signal was used. In reality, because of the random access nature of the scanning, the overall time-averaged efficiency of actual images is reduced. The more voxels that are displayed, the less efficient the scanner becomes. As an example, if the total voxel count is doubled from 19,000 to 38,000 then the total average power per voxel drops by a factor of about 80 due to the ever-decreasing duty cycle of the scanner. The average voxel intensity is usually below 1 microwatt, well within eye safety limits. Depending on the number of voxels used in the image, the brightness varies from several footlamberts to 0.1 foot-lambert. An example of an image formed by the scanning system is shown in figure 7.

Improvements in Electronics

Voltage Controlled Oscillators (VCOs) were replaced with Direct Digital Frequency Synthesizers for greater control over the X and Y deflection frequencies. Additional interface electronics for the deflection, intensity, and blanking for each of the four channels were also added, and the new Volumetric #2 board was used to supply the image signals to the 40k scanner channel Interface board. These changes allowed the green scanner to increase the number of displayed voxels from 4,000 to 38,461 at the 20Hz refresh rate (see figure 8).

The interface channel control circuitry had very critical timing adjustments. NRaD redesigned the electronics in this area to make the timing adjustments easier. Also, this unit did not have buffer circuits on the input X and Y data, clock, and Index A signals. These improvements were, subsequently, incorporated into the red 40k scanner.

POTENTIAL APPLICATIONS FOR 3-D VOLUMETRIC DISPLAY

Dual-sector applications to both the government and private sector best describes the potential use of this technology.

Submarine Attack Center

The Laser-Based 3-D Volumetric Display System offers a port to Navy's Submarine Attack Center for presenting a 3-D spatial awareness to viewers; like viewing the real underwater world in 3-D (see figure 9). This 3-D display approach allows a total spherical underwater world to be generated so that acoustic information is conveyed live in the Submarine's Attack Center, in spatially-relevant directions, to the submarine commander as well as to his staff.

NCCOSC RDT&E Division's developed Laser-Based 3-D Volumetric Display System can provide the following applications in real-time. At this writing SPAWAR's Submarine Communications Systems (PMW-153) and the C⁴I group have reviewed the Laser-Based 3-D Volumetric

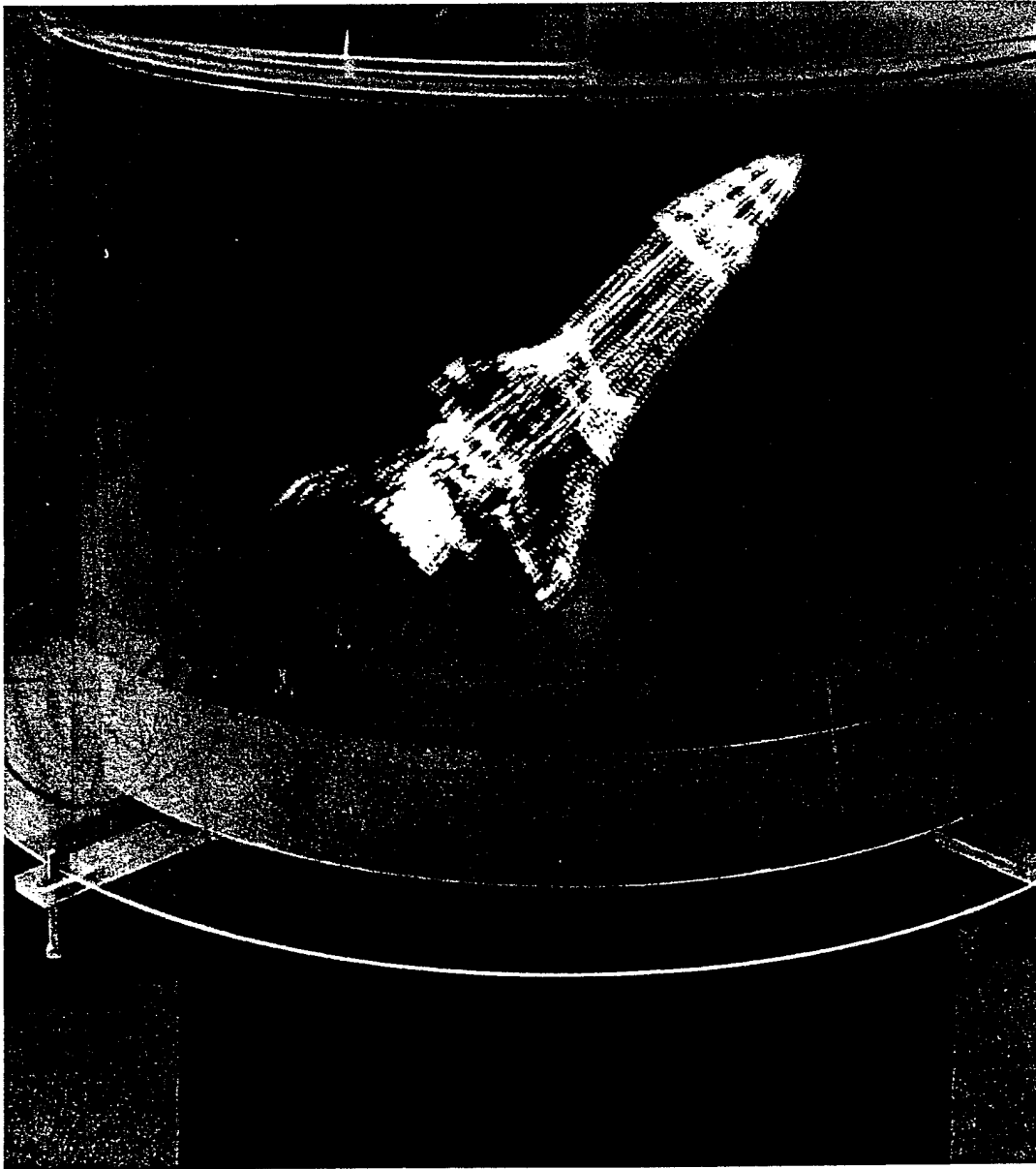

Figure 7. 2-Dimensional photo presentation of the 3-dimensional Volumetric Display.

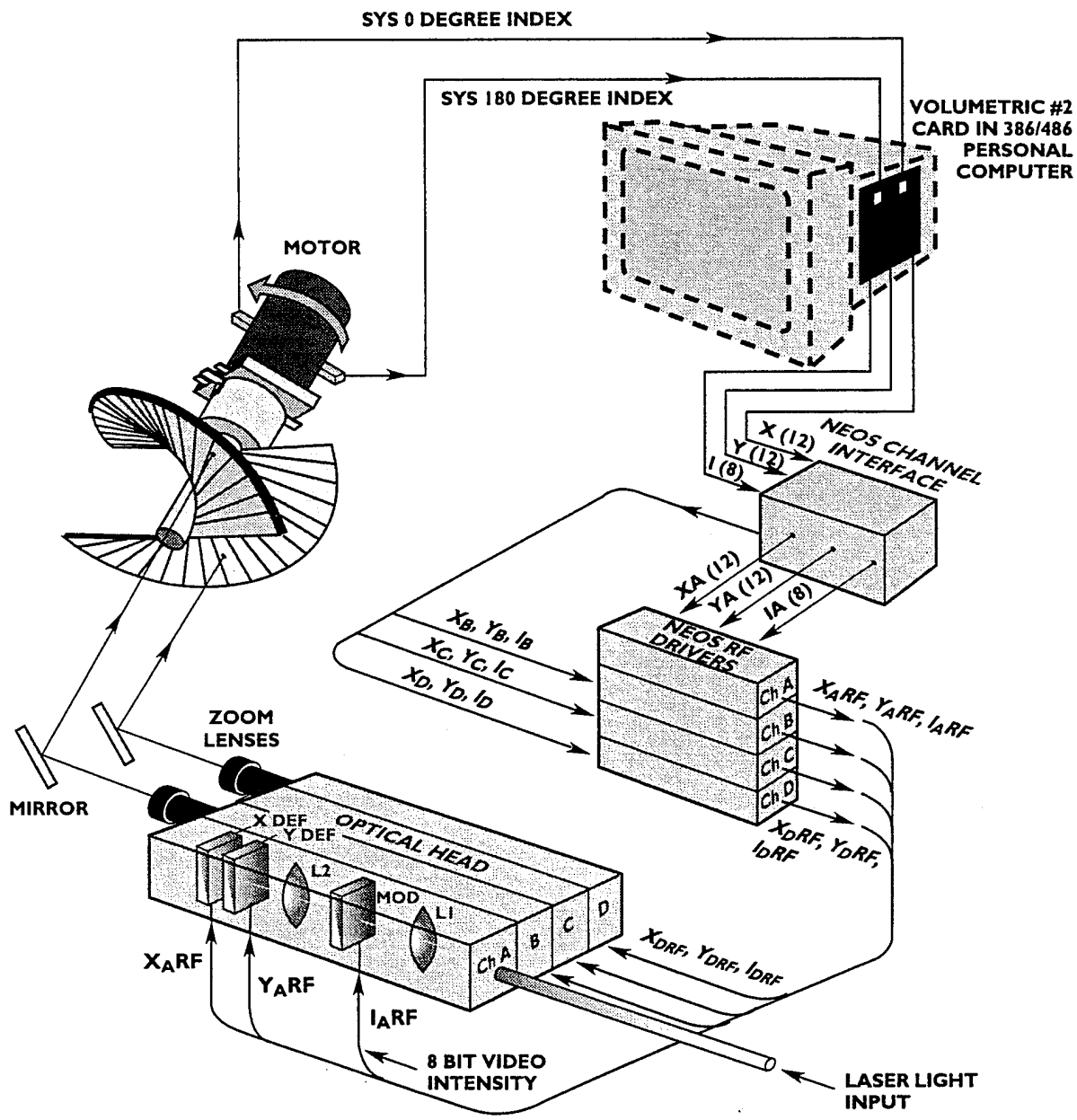

Figure 8. Flow diagram presenting computer-controlled, laser-projected 3-D images on a rotating double helix.

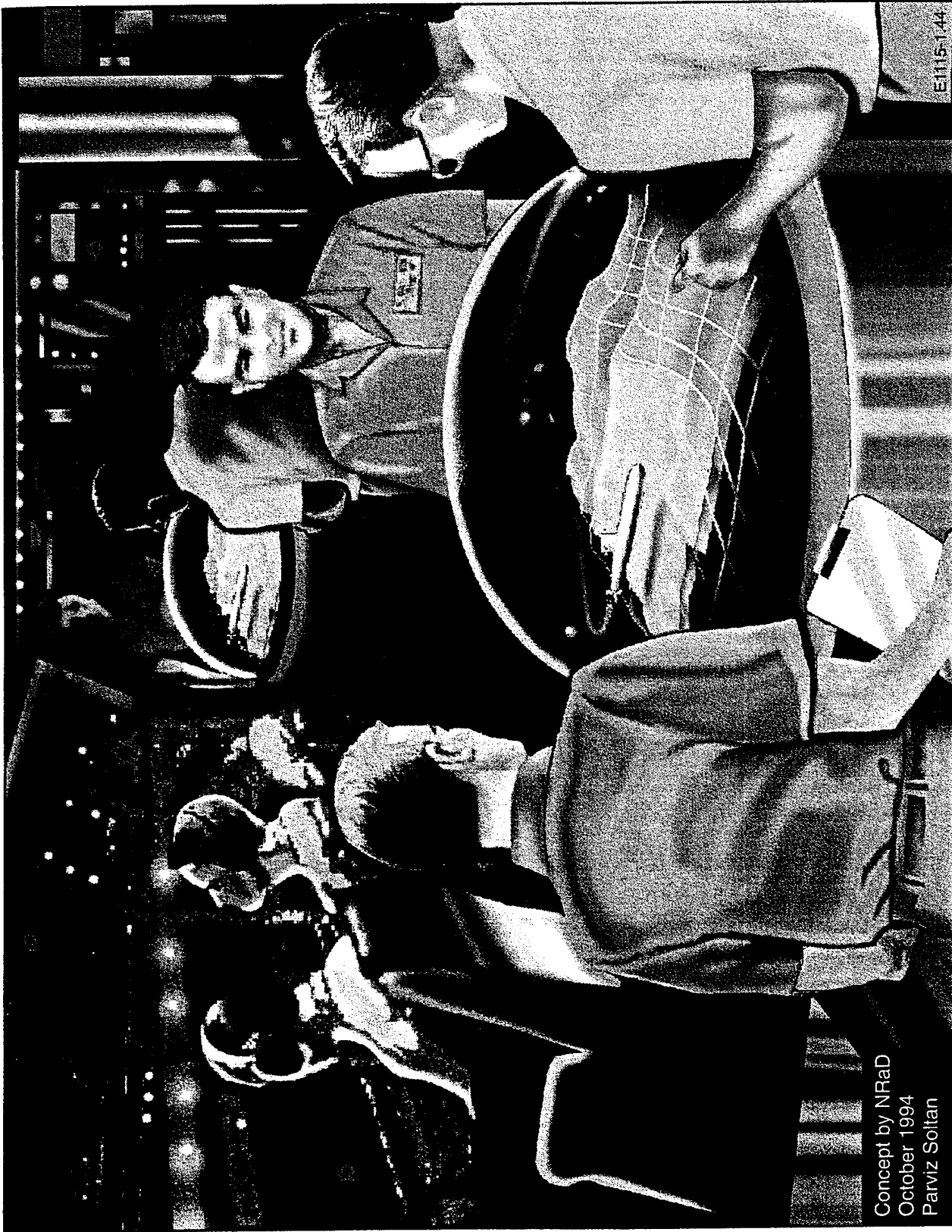

Figure 9. Navigating submarines in shallow waters, using 3-D Volumetric Display.

Display System and they are considering its implementation. There are several applications. Two of them are the Shallow Water Guidance of Submarines (figure 9) and Monitoring of Multiple Torpedoes in Three Dimensions—and all in real-time.

Command Centers/Global Communications

The Department of Defense Science and Technology Initiative identifies seven thrust areas. One of these is Global Surveillance and Communications, a capability that can focus on a trouble spot and be responsive to the needs of the commander. A three-dimensional display of the battle area—such as the Laser-Based 3-D Volumetric Display System—will greatly facilitate this capability. Tactical data collected for command review can be translated and displayed as 3-D images (see figure 10). The perspective gained will contribute to quicker and more accurate decision-making regarding deployment and management of battle resources. It actually helps to integrate force assets effectively, since it more realistically shows force deployments.

Air Traffic Control

The 3-D Volumetric Display is a logical application for control and management of air traffic in a volume of aerospace for the FAA, Air Force, or Navy (see figure 11). For the first time anywhere, 3-D air traffic control in real-time has been developed and demonstrated in the NRaD Laser Display Laboratory, in San Diego, California. Using authentic data obtained from the Identification Friend or

Foe (IFF) radar system located at NRaD, the standard 2-D plan position indicator (PPI) was automatically converted to a 3-D space plan position indicator (SPPI). The positions of over 80 airplanes in the San Diego aerospace were displayed graphically in green. The vital flight information for any airplane selected by a 3-D camera was displayed alphanumerically in red. This information included the Selective Identification Feature (SIF), range, azimuth, and altitude.

Three-Dimensional Medical Imaging (in Real-Time With Color)

Today, converting the 2-D data of conventional medical images into useful clinical information requires mentally integrating these data into a 3-D perspective. Yet, frequently, this is difficult even for experienced radiologists. Even with Magnetic Resonance Imaging (MRI), the end-product image is only a 2-D presentation of 3-D. The same can be said for the ultrasound imaging devices employed throughout hospitals and in clinical laboratories; they give the illusion of 3-D, using appropriately computed 2-D (flat) images. Employing the fully developed high-resolution images of the 3-D Volumetric Medical Display (see figure 12), all the soft tissues of the body can be monitored in 3-D color and in real-time. These tissues include such major organs as the heart, lungs, and liver. Even the unborn baby can be observed in 3-D, while in the birth canal. These medical applications are under development. (Also, the Laser-Based 3-D Volumetric Display System is a logical host for 3-D virtual reality software.)

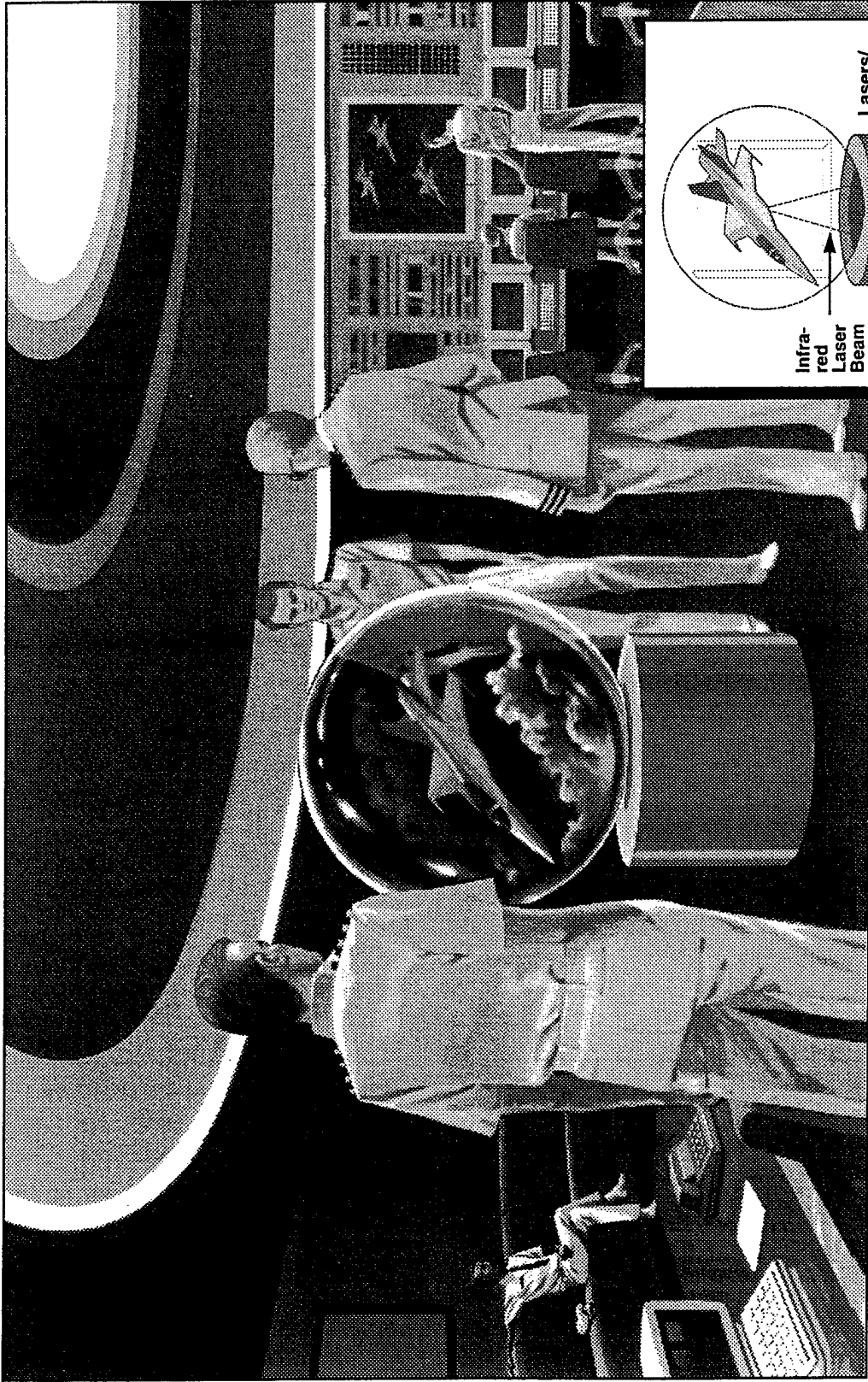

Laser Based 3-D Volumetric Display

Concept by NRaD
 November 1992
 P. Soltan

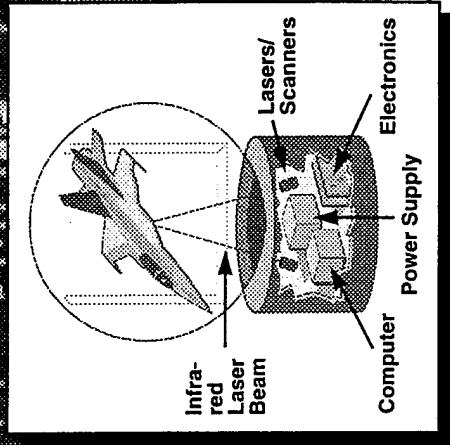

Figure 10. Laser-based 3-D Volumetric Display for C² applications.

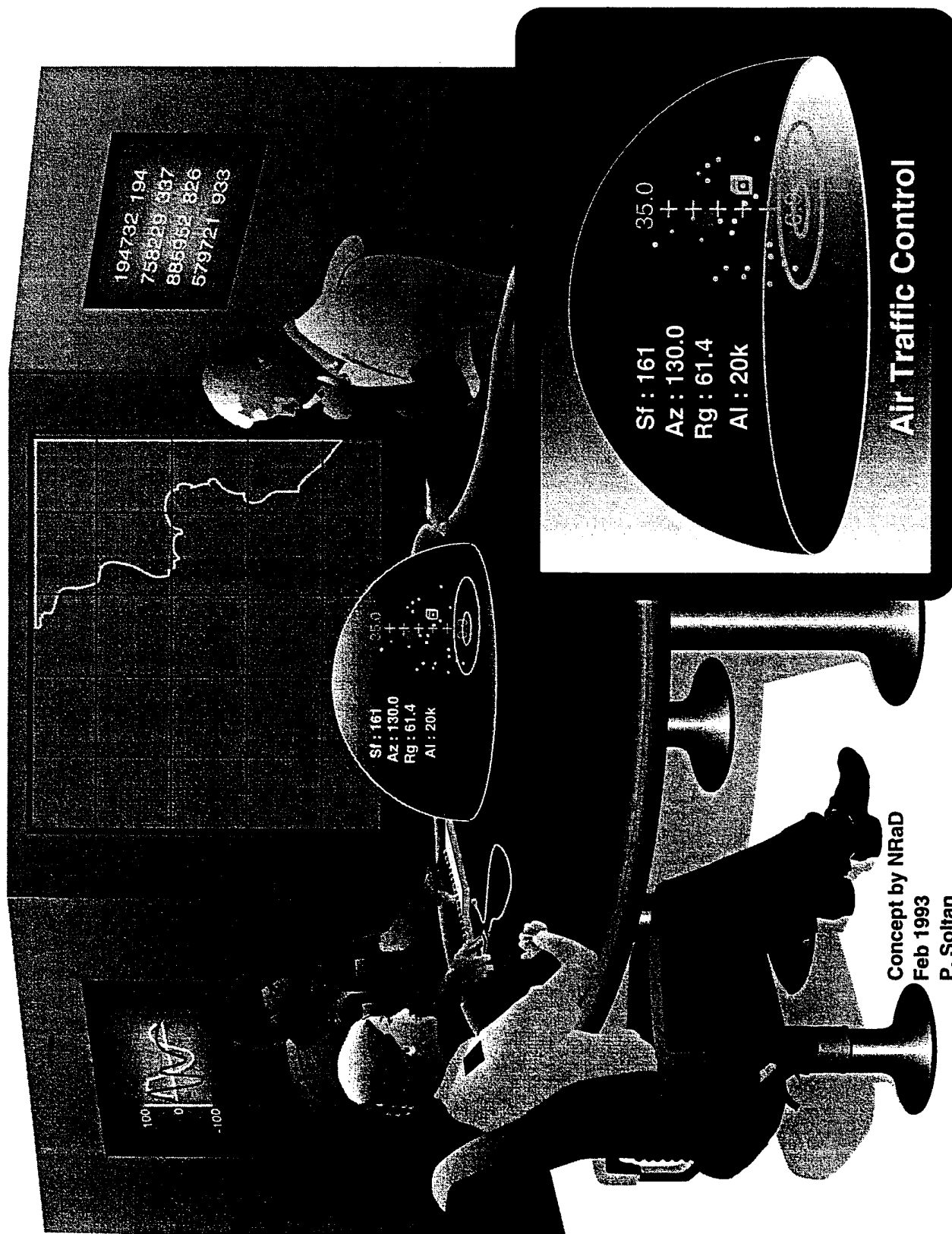

Figure 11. Laser-based 3-D Volumetric Display for air traffic control applications.

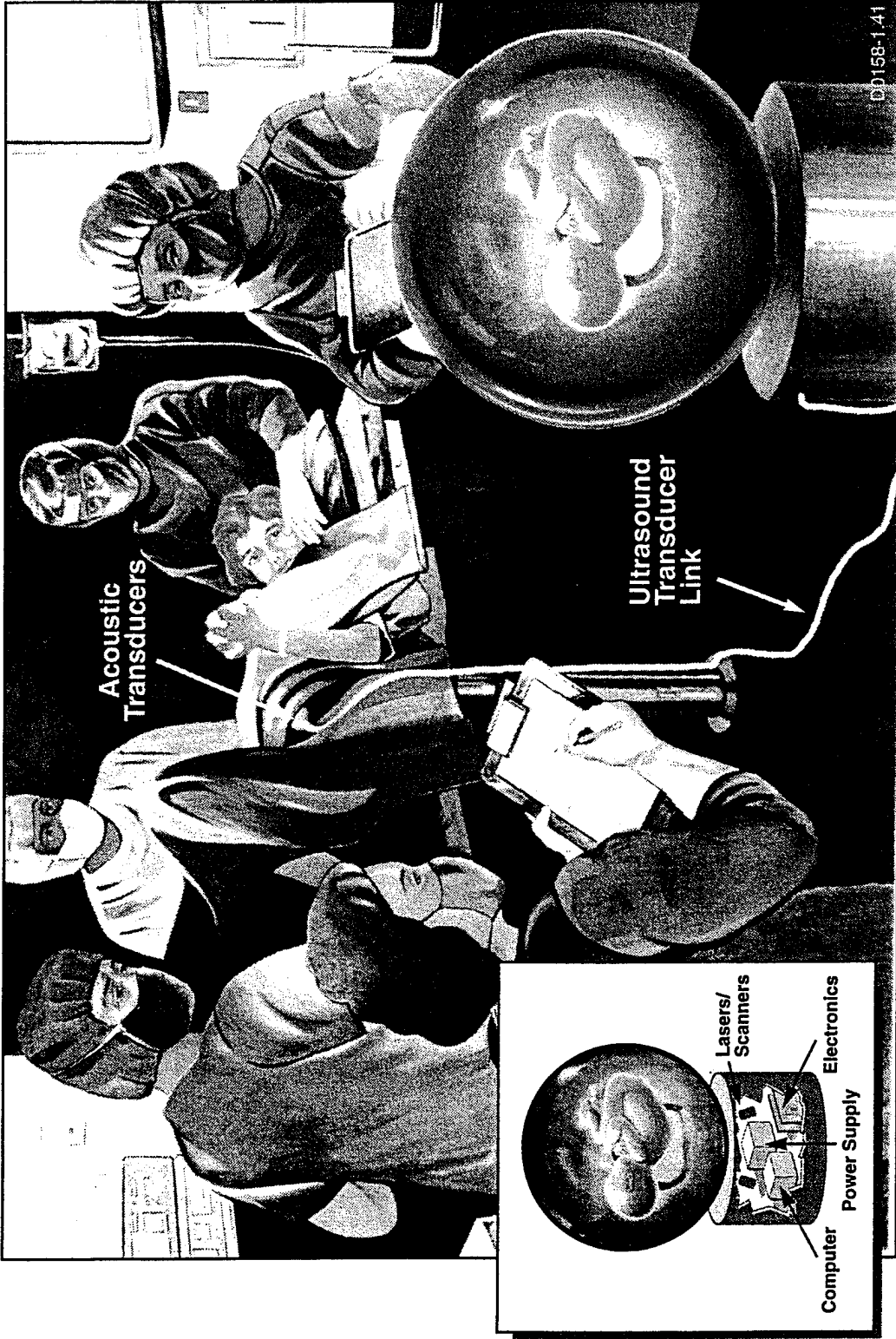

Figure 12. Laser-based 3-D Volumetric Medical display.

Concept by NRaD
 January 1994
 P. Soltan

REFERENCES

1. Brinkman, V. 1983. "A Laser-Based Three-Dimensional Display," *Laser and Applications*, vol. 2, no. 3.
2. Clifton, T. L., and F. L. Wefer. 1993. "Direct Volume Display Devices," *Computer Graphics and Applications*, vol. 13, no. 4, pp. 57-65, Jul 1993.
3. Furness III, T. A., "Harnessing Virtual Space," Armstrong Aerospace Medical Research Laboratory, *SID 1988 Digest*.
4. Soltan, P., J. Trias, W. Robinson, and W. Dahlke. 1992. "Laser Based 3-D Volumetric Display System (First Generation)," *SPIE - The International Society for Optical Engineering*, San Jose Convention Center, San Jose, CA, 9-14 Feb 1992.
5. Williams, R. D., and F. Garcia, Jr., "A Real Time Autostereoscopic Multiplanar 3D Display System," Texas Instruments, Inc., Dallas, TX, *SID 1988 Digest*.
6. Williams, R. D., and D. D. Loo. 1991. "Image Quality of Volumetric Displays, Emerging Technology and Needed Research," *SID 91 Digest*, Texas Instruments, Inc., Dallas, TX.
7. Williams, R. D., F. L. Wefer, and T. E. Clifton. 1992. "Direct Volumetric Visualization," *Proceedings of Visualization '92*, pp. 99-106, Boston, MA, 19-23 Oct 1992.

AUTHOR'S BIOGRAPHIES

Parviz Soltan Naval Command, Control and Ocean Surveillance Center, RDT&E Division, Code 44215, San Diego, CA 92152-5107. FAX 553-6763; email soltan@nosc.mil.

Parviz Soltan received his BS in Electrical Engineering from Lafayette College, MS in Physics from Syracuse University, IE Engineering from Columbia University. Graduate studies and participant in the PhD Program in Applied Physics at University of California San Diego (UCSD). Mr. Soltan presently conducts R&D on Flat Panel Display Technologies, Fiber Optics Technology, and 3-D Volumetric Laser Display. He worked previously at IBM's Poughkeepsie and Kingston Laboratories on computer design and plasma display technology development. He has several patents and has published several technical papers. He is the former President of the Optical Society of San Diego.

John A. Trias Naval Command, Control and Ocean Surveillance Center, RDT&E Division, Code 44215, San Diego, CA 92152-5107. FAX 553-6763; email trias@nosc.mil.

Mr. Trias received a bachelor's degree in physical science from the University of California at Berkeley in 1956. In the 1960s he worked on the synthesis of ruby and sapphire crystals for lasers. He has been with the Naval Ocean Systems Center (NOSC--now NRaD) since 1964. He worked with the development of new rare-earth chelates for dye lasers which were used in prototype optical communication projects at NOSC. In 1981, he developed and demonstrated the first laser-addressed liquid crystal light valve large-screen projection display system operating at video scan rates. His work as project leader for the Command Control Technology Task at NRaD has been to advance laser light valve display technology. His current interests are in the development of direct-view high-resolution laser displays using acousto-optic devices, and in 3-D volumetric displays using high-speed acousto-optic scanning and a nonmoving volume screen. Mr. Trias has 15 patents and has written 35 technical publications.

Weldon Dahlke Naval Command, Control and Ocean Surveillance Center, RDT&E Division, Code 44215, San Diego, CA 92152-5107. FAX 553-6763; email dahlke@nosc.mil.

Mr. Dahlke received a Bachelor of Science degree in Electrical Engineering from the University of Colorado at Boulder, Colorado in 1961. Before coming to NEL, he worked for Autonetics in Anaheim, CA as a Computer Field Engineer for the GAM 77 missile system at various Air Force and Navy installations. Since 1964 he has been with NCCOSC RDT&E DIV, and its predecessors NOSC and NEL working with experimental display techniques, technologies and systems in the command and control arena. His specialty is designing, building, and testing of digital and analog electronics for high resolution video display systems. His latest design is a ten-layer electronic control board containing 526 components that fits into a standard PC and precisely controls the laser beam's position on the 3-D Double Helix Display.

Mark Lasher Naval Command, Control and Ocean Surveillance Center, RDT&E
Division, Code 843, San Diego, CA 92152-5732. FAX 553-2521;
email lasher@nosc.mil.

Mr. Lasher received his bachelor's degree in Physics from the University of California at San Diego in 1980. He received a Master's degree in Physics from San Diego State University in 1983, and a Master's degree in Electrical Engineering from University of California at San Diego in 1989. He has been with the NCCOSC RDT&E Division since 1983, working in acousto-optic laser scanning and integrated optic devices for microwave systems. His work also includes research in photorefractive materials, bistability, optical switching, A/D conversion, signal processing systems and algorithm development. His most recent work is in the areas of laser scanners for display systems, laser colorimetry, and electro-optic devices for microwave communications applications.

Malvyn C. McDonald Naval Command, Control and Ocean Surveillance Center, RDT&E
Division, Code 813, San Diego, CA 92152-5780. FAX 553-6043;
email malvyn@nosc.mil.

Mr. McDonald received both his Bachelors of Science and Masters of Science degrees in Mechanical Engineering in 1971 and 1976, respectively, from San Diego State University. He has 23 years engineering experience with professional emphasis on design and development of shipboard, submarine, and shore-based communication systems, electronics and optics packaging systems, and structural and dynamic mechanical systems. He is experienced in development of systems from the conceptual stage to pre-production prototypes, including shock and vibration analyses, fabrication, testing and evaluation, and engineering documentation.

Approved for public release; distribution is unlimited.