

DAMPING CHARACTERISTICS OF FIBER COMPOSITES

by

ZVI HASHIN

DTIC QUALITY INSPECTED 4

MED Report No. 36

July 1972



המחלקה להנדסת חומרים
הטכניון - מכון טכנולוגי לישראל

DEPARTMENT OF MATERIALS ENGINEERING
TECHNION - ISRAEL INSTITUTE OF TECHNOLOGY
HAIFA, ISRAEL

19960328 079

Scientific Report No. 1
EOAR, USAF
Contract F 44620-71-C-0100

PLATES 19407

Qualified requestors may obtain additional copies from the Defense Documentation Center; all others should apply to the Clearinghouse for Federal Scientific and Technical Information.

CONTRACT F 44620-71-C-0100

JULY 1972

SCIENTIFIC REPORT NO. 1

DAMPING CHARACTERISTICS OF FIBER COMPOSITES

By

Zvi Hashin

MED Report No. 36

Department of Materials Engineering

Technion - Israel Institute of Technology

Haifa, Israel

The research reported in this document has been supported by the AIR FORCE OFFICE OF SCIENTIFIC RESEARCH under Contract F 44620-71-C-0100, through the European Office of Aerospace Research, (EOAR), United States Air Force.

This document has been approved for public release and sale; its distribution is unlimited.

Damping Characteristics of Fiber Composites^(*)

by

Zvi Hashin^(**)

Abstract

Analytical results for complex moduli of uniaxially fiber reinforced materials made of viscoelastic matrix and elastic fibers are reviewed. A general method is established to predict complex moduli and loss tangents of viscoelastic laminates made of uniaxially reinforced laminae. Application of results is demonstrated by two examples of analysis of damping of structural vibrations: Attenuation of vibrations in uniaxially reinforced Timoshenko beam and torsional vibrations of laminated cylinder.

(*) Presented at 8th International Council of the Aeronautical Sciences (ICAS) Congress, Amsterdam, August 28 - September 2, 1972.

(**) Professor, Department of Materials Engineering,
Technion - Israel Institute of Technology.

1. Introduction

The ever increasing use of fiber composites for aero/space structures requires the development of rational methods for prediction of their relevant properties within engineering accuracy.

In most current fiber composites the matrix is a polymer such as epoxy. It is well known that such polymers exhibit the effect of vibration damping. Therefore such damping effects will also occur in composites in which the matrix is polymeric. Since aero/space structures are subjected to severe vibrational environment and since vibration damping is beneficial, the quantitative prediction of such damping is of considerable engineering importance.

It is of interest to emphasize the unique combination of desirable properties which are exhibited by fiber composites: Superior strength and stiffness, low weight and vibration damping. No other materials seem to possess this many advantages.

In order to handle the problem analytically, it is assumed that the matrix is linearly viscoelastic. Its dynamic viscoelastic properties can then be characterized in terms of the usual complex moduli of viscoelasticity which are assumed to be known on the basis of experiments. The fibers are represented as linear elastic. The composite with such constituents behaves macroscopically as a linear viscoelastic body which is characterized by effective complex moduli. There arise three classes of important investigation:

(a) Prediction of effective complex moduli of a uniaxially reinforced material on the basis of matrix complex moduli; fiber elastic moduli and internal geometrical parameters such as constituent volume fractions, fiber shapes, etc.

(b) Prediction of the effective complex moduli of a laminate, whose laminae are composed of uniaxially reinforced material, on the basis of the uniaxial material effective complex moduli found in (a) and the laminate internal geometry.

(c) Viscoelastic vibration analysis of structures made of fiber composites.

These different kinds of problems will be discussed consecutively.

2. Complex Moduli of Uniaxially Fiber Reinforced Materials

A general theory of prediction of effective complex moduli of composites with linear viscoelastic constituents has been given previously [1], [2], [3]. It will here suffice to discuss without proof some results which are pertinent for the present investigation.

Let the local average strains and stresses in a composite be of oscillatory nature. Thus:

$$\begin{aligned}\bar{\epsilon}_{ij} &= \tilde{\epsilon}_{ij} e^{i\omega t} \\ \bar{\sigma}_{ij} &= \tilde{\sigma}_{ij} e^{i\omega t}\end{aligned}\tag{2.1}$$

where overbars denote average, $i = \sqrt{-1}$, ω is frequency, t is time and latin subscripts range over 1, 2, 3. The effective complex moduli \tilde{C}_{ijkl}^* of a generally anisotropic composite are defined by the relation:

$$\tilde{\sigma}_{ij} = \tilde{C}_{ijkl}^*(i\omega) \tilde{\epsilon}_{kl}\tag{a}$$

(2.2)

$$\tilde{C}_{ijkl}^*(i\omega) = C_{ijkl}^{*R}(\omega) + i C_{ijkl}^{*I}(\omega)\tag{b}$$

where superscripts R and I denote real and imaginary parts respectively.

The assumption is made that the fiber reinforced material under consideration is macroscopically transversely isotropic with respect to fiber direction. Then (2.2a) assumes the form:

$$\begin{aligned}\tilde{\sigma}_{11} &= \tilde{C}_{11} \tilde{\epsilon}_{11} + \tilde{C}_{12} \tilde{\epsilon}_{22} + \tilde{C}_{12} \tilde{\epsilon}_{33} \\ \tilde{\sigma}_{22} &= \tilde{C}_{12} \tilde{\epsilon}_{11} + \tilde{C}_{22} \tilde{\epsilon}_{22} + \tilde{C}_{22} \tilde{\epsilon}_{33} \\ \tilde{\sigma}_{33} &= \tilde{C}_{12} \tilde{\epsilon}_{11} + \tilde{C}_{23} \tilde{\epsilon}_{22} + \tilde{C}_{22} \tilde{\epsilon}_{33} \\ \tilde{\sigma}_{12} &= 2\tilde{C}_{44} \tilde{\epsilon}_{12} \\ \tilde{\sigma}_{23} &= (\tilde{C}_{22} - \tilde{C}_{23})\tilde{\epsilon}_{23} \\ \tilde{\sigma}_{31} &= 2\tilde{C}_{44} \tilde{\epsilon}_{31}\end{aligned}\tag{2.3}$$

where x_1 is in fiber direction and x_2, x_3 are in the transverse plane, Fig. 1.

In another notation, the complex moduli in (2.3) are written:

$$\begin{aligned}\tilde{C}_{11} &= \tilde{n} \\ \tilde{C}_{12} &= \tilde{\ell} \\ \tilde{C}_{22} &= \tilde{k} + \tilde{G}_T \\ \tilde{C}_{23} &= \tilde{k} - \tilde{G}_T \\ \tilde{C}_{44} &= \tilde{G}_A\end{aligned}\tag{2.4}$$

Here \tilde{k} is a transverse complex bulk modulus, \tilde{G}_T - transverse complex shear modulus in x_2, x_3 plane and \tilde{G}_A - axial complex shear modulus in planes containing fiber direction x_1 . The physical interpretation of \tilde{n} and $\tilde{\ell}$ is here of little interest.

Inversion of (2.3) is written in the form:

$$\begin{aligned}\tilde{\epsilon}_{11} &= \frac{1}{\tilde{E}_A} \tilde{\sigma}_{11} - \frac{\tilde{\nu}_A}{\tilde{E}_A} \tilde{\sigma}_{22} - \frac{\tilde{\nu}_A}{\tilde{E}_A} \tilde{\sigma}_{33} \\ \tilde{\epsilon}_{22} &= -\frac{\tilde{\nu}_A}{\tilde{E}_A} \tilde{\sigma}_{11} + \frac{1}{\tilde{E}_T} \tilde{\sigma}_{22} - \frac{\tilde{\nu}_T}{\tilde{E}_T} \tilde{\sigma}_{33} \\ \tilde{\epsilon}_{33} &= -\frac{\tilde{\nu}_A}{\tilde{E}_A} \tilde{\sigma}_{11} - \frac{\tilde{\nu}_T}{\tilde{E}_T} \tilde{\sigma}_{22} + \frac{1}{\tilde{E}_T} \tilde{\sigma}_{33} \\ \tilde{\epsilon}_{12} &= \frac{\tilde{\sigma}_{12}}{2\tilde{G}_A} \\ \tilde{\epsilon}_{23} &= \frac{\tilde{\sigma}_{23}}{2\tilde{G}_T} \\ \tilde{\epsilon}_{31} &= \frac{\tilde{\sigma}_{31}}{2\tilde{G}_A}\end{aligned}\tag{2.5}$$

where \tilde{E}_A and \tilde{E}_T are complex Youngs' moduli in axial (fiber) direction and transverse (to fiber) direction, respectively, and $\tilde{\nu}_A$ and $\tilde{\nu}_T$ are associated complex Poisson's ratios.

Establishment of analytical expressions for the various effective complex moduli listed above in terms of matrix complex moduli, fiber elastic moduli and phase geometry is based on a correspondence principle [1], [2] which states: The effective complex moduli of a viscoelastic composite are obtained by replacement of phase elastic moduli by phase complex moduli of a composite with identical phase geometry.

In the usual fiber reinforced materials the following conditions are

usually fulfilled with sufficient accuracy

- (a) Fibers are by an order of magnitude stiffer than matrix
- (b) The matrix is isotropic and is viscoelastic in shear only
- (c) The matrix shear loss tangent is not larger than 0.1. Thus:

$$\tan \delta_G^m = \frac{G_m^I}{G_m^R} \leq 0.1 \quad (2.6)$$

Under these conditions the following results have been shown [3] to be valid.

(d) The imaginary parts of the effective complex moduli, \tilde{n} , \tilde{l} , \tilde{k} , \tilde{E}_A are much smaller than the imaginary parts of the effective shear moduli \tilde{G}_A , \tilde{G}_T , and of \tilde{E}_T .

(e) To obtain real parts of all effective complex moduli it is merely necessary to take corresponding expressions for effective elastic moduli and to replace in them matrix elastic moduli by real parts of matrix complex moduli.

Some simple general results which are valid under the conditions listed above will now be given:

$$\begin{aligned} \tilde{E}_A(\omega) &= \tilde{E}_m(\omega) v_m + E_f v_f \\ E_A^R(\omega) &= E_m^R(\omega) v_m + E_f v_f \\ E_A^I(\omega) &= E_m^I(\omega) v_m \end{aligned} \quad (2.7)$$

$$\tan \delta_E = \frac{E_A^I}{E_A^R} = \frac{\tan \delta_E^m}{1 + E_f v_f / E_m^R v_m} \ll \tan \delta_E^m$$

Here m and f denote matrix and fibers, respectively, and v stands for volume fraction, $\tan \delta_E$ is the loss tangent for uniaxial stressing in fiber direction while $\tan \delta_E^m$ is the corresponding loss tangent for the isotropic matrix.

For axial shear

$$\begin{aligned}\tilde{G}_A(\omega) &= \tilde{G}_m(\omega) \frac{1 + v_f}{1 - v_f} \\ G_A^R(\omega) &= G_m^R \frac{1 + v_f}{1 - v_f} \\ G_A^I(\omega) &= G_m^I \frac{1 + v_f}{1 - v_f}\end{aligned}\tag{2.8}$$

$$\tan \delta_{G_A} = \tan \delta_G^m$$

For transverse shear

$$\begin{aligned}G_T^I &\approx G_T^R \tan \delta_G^m \\ \tan \delta_{G_T} &= \tan \delta_G^m\end{aligned}\tag{2.9}$$

An expression for G_T^R has been given in [2], [3]. Results for other complex moduli may also be found in these references.

3. Complex Moduli of Laminates

The laminates to be considered are composed of plane laminae of uniaxially fiber reinforced materials, the direction of reinforcement being different in each lamina. The laminate is referred to a fixed coordinate system x_1, x_2, x_3 where x_1, x_2 are in the plane of the laminae and x_3 is normal to it, Fig. 2. The n th lamina in the laminate is referred to a material system of axes $x_1^{(n)}, x_2^{(n)}, x_3$ where $x_1^{(n)}$ is normal to the fibers and x_3 coincides with the laminate x_3 . The position of the $x_1^{(n)}, x_2^{(n)}$ system is defined with respect to the x_1, x_2 system by the reinforcement angle

$$\theta_n = \angle (x_1^{(n)}, x_1) \quad (3.1)$$

Fundamental assumptions of fiber composite laminate theory are: (a) Any lamina can be replaced by a homogenous material whose properties are the effective properties of the uniaxial FRM of which the lamina is made.

(b) The laminae are in states of plane stress.

First an elastic laminate will be considered. The plane stress-strain relations of a lamina referred to its material system of axes $x_1^{(n)}, x_2^{(n)}$ are then:

$$\begin{aligned} \epsilon_{11}^{(n)} &= \frac{1}{E_A} \sigma_{11}^{(n)} - \frac{\nu_A}{E_A} \sigma_{22}^{(n)} \\ \epsilon_{22}^{(n)} &= -\frac{\nu_A}{E_A} \sigma_{11}^{(n)} + \frac{1}{E_T} \sigma_{22}^{(n)} \\ \epsilon_{12}^{(n)} &= \frac{\sigma_{12}^{(n)}}{2G_A} \end{aligned} \quad (3.2)$$

where:

E_A - axial Young's modulus (in fiber direction)

ν_A - associated axial Poisson's ratio

E_T - transverse Young's modulus (normal to fibers)

G_A - axial shear modulus (in $x_1^{(n)}, x_2^{(n)}$ plane)

The inverse of (3.2) is:

$$\begin{aligned}\sigma_{11}^{(n)} &= C_{111} \varepsilon_{11}^{(n)} + C_{12} \varepsilon_{22}^{(n)} \\ \sigma_{22}^{(n)} &= C_{12} \varepsilon_{11}^{(n)} + C_{22} \varepsilon_{22}^{(n)} \\ \sigma_{12}^{(n)} &= 2C_{44} \varepsilon_{12}\end{aligned}\tag{3.3}$$

where

$$\begin{aligned}C_{11} = C_{1111} &= \frac{E_A}{1 - \frac{E_A}{E_T} \nu_A^2} \\ C_{12} = C_{1122} &= \frac{\nu_A E_T}{1 - \frac{E_A}{E_T} \nu_A^2} \\ C_{22} = C_{2222} &= \frac{E_T}{1 - \frac{E_A}{E_T} \nu_A^2} \\ C_{44} = C_{1212} &= G_A\end{aligned}\tag{3.4}$$

In terms of the four index moduli in (3.4), (3.3) can be written compactly as:

$$\sigma_{\alpha\beta}^{(n)} = C_{\alpha\beta\gamma\delta}^{(n)} \epsilon_{\gamma\delta}^{(n)} \quad (3.5)$$

where here and from now on Greek indices range over 1, 2.

For the sake of simplicity there will be considered the special group of laminates in which the application of membrane force $N_{\alpha\beta}$ in the plane of the laminate does not induce bending or torsion in the laminae. The most important kind of laminate which fulfills this requirement is a symmetric laminate. Such a laminate has the property that its middle plane is a plane of symmetry for the geometry and elastic moduli of the laminate. The laminate is thus composed of laminae pairs in each of which the laminae are of same thickness, are symmetrically located with respect to the middle plane and have the same elastic properties with respect to the x_1, x_2 system.

The last condition is most commonly fulfilled by laminae made of identical material and same reinforcement angle θ_n (3.1), in each pair. The elastic stress-strain relation of such a laminate is given by

$$\bar{\sigma}_{\alpha\beta} = \frac{N_{\alpha\beta}}{h} = C_{\alpha\beta\gamma\delta}^* \bar{\epsilon}_{\gamma\delta} \quad (a)$$

$$C_{\alpha\beta\gamma\delta}^* = \sum_{n=1}^N {}^{(n)}C_{\alpha\beta\gamma\delta} t_n/h \quad (b)$$

(3.6)

where

$\bar{\sigma}_{\alpha\beta}$ - applied average plane stress

$\bar{\epsilon}_{\alpha\beta}$ - average strain

h - laminate thickness

$C_{\alpha\beta\gamma\delta}^*$ - effective elastic moduli of laminate

t_n - thickness of n^{th} lamina

N - number of laminae

$^{(n)}C_{\alpha\beta\gamma\delta}$ - the laminae elastic moduli (3.4) transformed to the x_1, x_2 system of axes.

For establishment of the result (3.6) see e.g. [4]. Proof that (3.6) is based on an elasticity solution which is exact in the Saint Venant sense for a laminate whose thickness is small compared to its plane dimensions has been given by B.W. Rosen (unpublished).

Let it be now assumed that the laminate is viscoelastic but remains symmetric as described above. The laminate is subjected to oscillatory membrane loads

$$N_{\alpha\beta} = \tilde{N}_{\alpha\beta} e^{i\omega t} \quad (3.7)$$

The average stresses associated with (3.7) are then:

$$\bar{\sigma}_{\alpha\beta} = \frac{N_{\alpha\beta}}{h} = \frac{\tilde{N}_{\alpha\beta}}{h} e^{i\omega t} = \bar{\sigma}_{\alpha\beta} e^{i\omega t} \quad (3.8)$$

The strain response of the laminate is

$$\bar{\epsilon}_{\alpha\beta} = \tilde{\epsilon}_{\alpha\beta} e^{i\omega t} \quad (3.9)$$

The relation between $\tilde{\sigma}_{\alpha\beta}$ and $\tilde{\epsilon}_{\alpha\beta}$ is written:

$$\tilde{\sigma}_{\alpha\beta} = \tilde{C}_{\alpha\beta\gamma\delta}^* (i\omega) \tilde{\epsilon}_{\gamma\delta} \quad (3.10)$$

where $\tilde{C}_{\alpha\beta\gamma\delta}^*$ are the effective complex moduli of the laminate.

It follows by the general correspondence principle of [1] which was quoted above that $\tilde{C}_{\alpha\beta\gamma\delta}^*$ can be expressed in form (3.6b). Thus:

$$C_{\alpha\beta\gamma\delta}^* (i\omega) = \sum_{n=1}^N {}^{(n)}\tilde{C}_{\alpha\beta\gamma\delta} (i\omega) t_n/h \quad (3.11)$$

The single laminae complex moduli ${}^{(n)}\tilde{C}_{\alpha\beta\gamma\delta}$ in (3.11) are interpreted as follows: In the material axes $x_1^{(n)}$, $x_2^{(n)}$ of the nth lamina the stresses and strains are:

$$\sigma_{\alpha\beta}^{(n)} = \tilde{\sigma}_{\alpha\beta}^{(n)} e^{i\omega t} \quad (3.12)$$

$$\epsilon_{\alpha\beta}^{(n)} = \tilde{\epsilon}_{\alpha\beta}^{(n)} e^{i\omega t}$$

The relation between $\tilde{\sigma}_{\alpha\beta}^{(n)}$ and $\tilde{\epsilon}_{\alpha\beta}^{(n)}$ in (3.12) is of type (3.3-3.4).

Thus:

$$\tilde{\sigma}_{\alpha\beta}^{(n)} = \tilde{C}_{\alpha\beta\gamma\delta}^{(n)} \tilde{\epsilon}_{\gamma\delta}^{(n)} \quad (3.13)$$

$$\tilde{C}_{1111} = \tilde{C}_{11} = \frac{\tilde{E}_A}{1 - \frac{\tilde{E}_T}{\tilde{E}_A} \tilde{\nu}_A^2}$$

$$\tilde{C}_{1122} = \tilde{C}_{12} = \frac{\tilde{\nu}_A \tilde{E}_T}{1 - \frac{\tilde{E}_T}{\tilde{E}_A} \tilde{\nu}_A^2} \quad (3.14)$$

$$\tilde{C}_{2222} = \tilde{C}_{22} = \frac{\tilde{E}_T}{1 - \frac{\tilde{E}_T}{\tilde{E}_A} \tilde{\nu}_A^2}$$

$$\tilde{C}_{1212} = \tilde{C}_{44} = \tilde{G}_A$$

where \tilde{E}_A , \tilde{E}_T , $\tilde{\nu}_A$ and \tilde{G}_A are the effective complex moduli of the uniaxial material which were discussed in par. 2.

If the complex stress strain relation (3.13) is transformed to the laminate axes x_1, x_2 it assumes the form:

$${}^{(n)}\tilde{\sigma}_{\alpha\beta} = {}^{(n)}\tilde{C}_{\alpha\beta\gamma\delta} {}^{(n)}\tilde{\epsilon}_{\gamma\delta} \quad (3.15)$$

This defines the ${}^{(n)}\tilde{C}_{\alpha\beta\gamma\delta}$ in (3.11).

By tensor transformation:

$$\begin{aligned} {}^{(n)}\tilde{C}_{1111} = {}^{(n)}\tilde{C}_{11} &= \tilde{C}_{11}\cos^4\theta_n + \tilde{C}_{22}\sin^4\theta_n + \\ &+ 2\tilde{C}_{12}\cos^2\theta_n\sin^2\theta_n + 4\tilde{C}_{44}\cos^2\theta_n\sin^2\theta_n \end{aligned}$$

$$\begin{aligned} {}^{(n)}\tilde{C}_{1122} = {}^{(n)}\tilde{C}_{12} &= (\tilde{C}_{11} + \tilde{C}_{22})\cos^2\theta_n\sin^2\theta_n + \\ &+ \tilde{C}_{12}(\cos^4\theta_n + \sin^4\theta_n) - 4\tilde{C}_{44}\cos^2\theta_n\sin^2\theta_n \end{aligned}$$

$$\begin{aligned} {}^{(n)}\tilde{C}_{2222} = {}^{(n)}\tilde{C}_{22} &= \tilde{C}_{11}\sin^4\theta_n + \tilde{C}_{22}\cos^4\theta_n + \\ &+ 2\tilde{C}_{12}\cos^2\theta_n\sin^2\theta_n + 4\tilde{C}_{44}\cos^2\theta_n\sin^2\theta_n \end{aligned}$$

(3.16)

$$\begin{aligned} {}^{(n)}\tilde{C}_{1112} = {}^{(n)}\tilde{C}_{14} &= -\tilde{C}_{11}\cos^3\theta_n\sin\theta_n + \\ &+ \tilde{C}_{22}\cos\theta_n\sin^3\theta_n + \tilde{C}_{12}(\cos^3\theta_n\sin\theta_n - \cos\theta_n\sin^3\theta_n) + \\ &+ 2\tilde{C}_{44}(\cos^3\theta_n\sin\theta_n - \cos\theta_n\sin^3\theta_n) \end{aligned}$$

$$\begin{aligned} {}^{(n)}\tilde{C}_{2212} = {}^{(n)}\tilde{C}_{24} &= -\tilde{C}_{11}\cos\theta_n\sin^3\theta_n + \\ &+ \tilde{C}_{22}\cos^3\theta_n\sin\theta_n + \tilde{C}_{12}(\cos\theta_n\sin^3\theta_n - \cos^3\theta_n\sin\theta_n) + \\ &+ 2\tilde{C}_{44}(\cos\theta_n\sin^3\theta_n - \cos^3\theta_n\sin\theta_n) \end{aligned}$$

$$\begin{aligned} {}^{(n)}\tilde{C}_{1212} = {}^{(n)}\tilde{C}_{44} &= (\tilde{C}_{11} + \tilde{C}_{22})\cos^2\theta_n \sin^2\theta_n - \\ &- 2\tilde{C}_{12}\cos^2\theta_n \sin^2\theta_n + \tilde{C}_{44}(\cos^2\theta_n - \sin^2\theta_n)^2 \end{aligned} \quad \begin{array}{l} (3.16 \\ \text{cont'd}) \end{array}$$

The preceding developments together with the results for complex moduli of uniaxially fiber reinforced materials define the computation methods of the effective complex moduli of symmetric laminates as expressed by (3.11).

For practical purposes it is frequently necessary to compute the effective complex compliances which are defined as the inverse of (3.11). In matrix notation:

$$\underline{\tilde{C}}^* \cdot \underline{\tilde{S}}^* = \underline{J} \quad (3.17)$$

where $\underline{\tilde{S}}^*$ denotes the effective complex compliance matrix and \underline{J} is the unit matrix. Separation of (3.17) into real and imaginary parts yields

$$\begin{aligned} \underline{C}^{*R} \cdot \underline{S}^{*R} - \underline{C}^{*I} \cdot \underline{S}^{*I} &= \underline{J} \quad (a) \\ \underline{C}^{*R} \cdot \underline{S}^{*I} + \underline{C}^{*I} \cdot \underline{S}^{*R} &= 0 \end{aligned} \quad (3.18)$$

Great facilitation is achieved if it is noted that in view of (2.6) the second term in the left side of (3.18a) can be neglected with respect to the first. It then follows:

$$\begin{aligned} \underline{C}^{*R} \cdot \underline{S}^{*R} &= \underline{J} \quad (a) \\ \underline{S}^{*I} &= -\underline{S}^{*R} \cdot \underline{C}^{*I} \cdot \underline{S}^{*R} \quad (b) \end{aligned} \quad (3.19)$$

Thus, once \underline{C}^{*R} and \underline{C}^{*I} have been computed from (3.11), (3.19) define the effective complex compliance matrix by simple real matrix operations.

Another important simplification is obtained if in the laminate to each pair with reinforcement angle θ_n and thickness t_n corresponds another pair with reinforcement $-\theta_n$ and same thickness t_n . It is then easily realized by the form of (3.16) that all contributions to (3.11) of terms with odd powers of $\cos\theta_n$ and $\sin\theta_n$ cancel mutually. Thus in this event the effective complex moduli matrix (3.11) has the form

$$\underline{\tilde{C}}^* = \begin{bmatrix} \tilde{C}_{1111}^* & \tilde{C}_{1122}^* & 0 \\ \tilde{C}_{1122}^* & \tilde{C}_{2222}^* & 0 \\ 0 & 0 & \tilde{C}_{1212}^* \end{bmatrix} = \begin{bmatrix} \tilde{C}_{11}^* & \tilde{C}_{12}^* & 0 \\ \tilde{C}_{12}^* & \tilde{C}_{22}^* & 0 \\ 0 & 0 & \tilde{C}_{44}^* \end{bmatrix} \quad (3.20)$$

and so the laminate is macroscopically orthotropic. The situation just described is of frequent practical occurrence. For example a symmetric laminate with laminae reinforcement in $\theta_n = 0, 90^\circ, \pm 45^\circ$ directions.

4. Structural Applications

4.1 Free flexural vibrations of a fiber reinforced beam

As a first example there is considered the case of free flexural vibrations of a simply supported beam which is uniaxially reinforced in beam axis direction. The purpose of the investigation is to compare vibration damping due to matrix viscoelasticity on the basis of the usual theory which neglects the effect of shear and on the basis of the more refined Timoshenko theory which takes into account shear as well as rotatory inertia. For isotropic materials, in which the complex Young's modulus loss tangent and the complex shear modulus loss tangent are of same order, the added effect of shear and rotatory inertia is small for vibration modes of low order and for long beams. In the present case, however, where the axial Young's modulus loss tangent is by an order of magnitude smaller than that of the axial shear modulus (section 2) the situation is quite different as will be shown below:

Considering only the effect of flexure the differential equation of the freely vibrating beam is:

$$c^2 \frac{\partial^2 w}{\partial x^4} + \frac{\partial^2 w}{\partial t^2} = 0 \quad (a)$$

$$c^2 = \frac{\tilde{E}_A I}{\rho A} \quad (b)$$

(4.1)

where:

\tilde{E}_A - complex axial Young's modulus

I - moment of inertia

A - area of cross section

ρ - density

Boundary conditions of free support are:

$$w, \frac{\partial^2 w}{\partial x^2} = 0 \quad x = 0, \ell \quad (4.2)$$

Conventional viscoelastic vibrations analysis shows that the modes of vibration are given by

$$w_n(x, t) = A_n \sin \frac{n\pi x}{\ell} \exp\left(-\frac{1}{2} \omega_n^R \tan \delta_E t\right) \exp(i\omega_n^R t) \quad (4.3)$$

where A_n is an arbitrary constant and

$$\omega_n^R = \frac{n^2 \pi^2}{\ell^2} \sqrt{\frac{E^R I}{\rho A}} \quad (a)$$

(4.4)

$$\tan \delta_E = \frac{\tan \delta_E^m}{1 + \frac{E_f^R v_f}{E_m^R v_m}} \quad (b)$$

Equ. (4.4b) is a repetition of (2.7d). The results are valid for small enough loss tangents, of order (2.6). The attenuation η_n is defined by

$$\eta_n = \frac{\omega_n^R}{2} \tan \delta_E \quad (4.5)$$

Next the same beam is considered in Timoshenko fashion, with shear and rotatory inertia. By the correspondence principle for viscoelastic vibrations [5], the elastic Timoshenko beam equation [6] transforms into

$$c^2 \frac{\partial^4 w}{\partial x^4} + \frac{\partial^2 w}{\partial t^2} - r^2 \left(1 + \frac{k\tilde{E}_A}{\tilde{G}_A} \right) \frac{\partial^4 w}{\partial x^2 \partial t^2} + \frac{kr^2 \rho}{\tilde{G}_A} \frac{\partial^4 w}{\partial t^4} = 0 \quad (4.6)$$

where c^2 is given by (4.1b), \tilde{G}_A is the axial complex shear modulus (2.8a), k is the strength of materials shear shape factor of the section and $r^2 = I/A$.

Equ. (4.6) with boundary conditions of simple support admits a solution of the form, [6]:

$$w_n(x,t) = A_n \sin \frac{n\pi x}{l} e^{i\hat{\omega}_n t} \quad (4.7)$$

where $\hat{\omega}_n$ is a solution of the complex frequency equation:

$$c^2 \alpha_n^4 - [1 + \alpha_n^2 r^2 (1 + \frac{k\tilde{E}_A}{\tilde{G}_A})] \hat{\omega}_n^2 + \frac{kr^2 \rho}{\tilde{G}_A} \hat{\omega}_n^4 = 0 \quad (a)$$

(4.8)

$$\alpha_n = \frac{n\pi}{l} \quad (b)$$

The solution of (4.8) is the complex "frequency"

$$\hat{\omega}_n = \hat{\omega}_n^R + i\hat{\omega}_n^I \quad (4.9)$$

In the case of small loss tangents of order (2.6) it can be shown by straightforward calculations that:

$$c^{R^2} \alpha_n^4 - [1 + \alpha_n^2 r^2 (1 + \frac{kE_A^R}{G_A^R})] \hat{\omega}_n^{R^2} + \frac{kr^2 \rho}{G_A^R} \hat{\omega}_n^{R^4} = 0 \quad (a) \quad (4.10)$$

$$c^{R^2} = \frac{E_A^R I}{\rho A} \quad (b)$$

$$\hat{\omega}_n^I = \frac{\hat{\omega}_n^R (\hat{\omega}_n^R kr^2 \rho / G_A^R - \alpha_n^2 r^2 kE_A^R / G_A^R) \tan \delta_G - (c^{R^2} \alpha_n^4 / \hat{\omega}_n^{R^2} - \alpha_n^2 kr^2 E_A^R / G_A^R) \tan \delta_E}{2 \hat{\omega}_n^{R^2} kr^2 \rho / G_A^R - [1 + \alpha_n^2 \gamma^2 (1 + kE_A^R / G_A^R)]} \quad (4.11)$$

It is seen that (4.10) is the frequency equation of an elastic Timoshenko beam in terms of real parts of complex moduli. Its validity is based on the usual additional assumption that real parts of complex moduli vary sufficiently slowly with frequency. Once $\hat{\omega}_n^R$ has been computed from (4.10), $\hat{\omega}_n^I$ can be computed from (4.11).

A mostly sufficient accurate approximation for $\hat{\omega}_n^R$ is:

$$\hat{\omega}_n^R \cong c^R \alpha_n^2 [1 - \frac{1}{2} \alpha_n^2 r^2 (1 + \frac{kE_A^R}{G_A^R})] \quad (4.12)$$

For slender beams and low modes the first term in each of numerator and denominator of (4.11) is insignificant relative to the others. Thus:

$$\hat{\omega}_n^I \approx$$

$$\frac{(\alpha_n^2 r^2 k E_A^R / G_A^R) \tan \delta_G + (c^{R^2} \alpha_n^4 / \hat{\omega}_n^{R^2}) \tan \delta_E}{1 + \alpha_n^2 r^2 (1 + k E_A^R / G_A^R)} \quad (4.13)$$

Substitution of (4.9) into (4.7) results in:

$$w_n(x, t) = A_n \sin \frac{n\pi x}{c} e^{-\hat{\omega}_n^I t} e^{i \hat{\omega}_n^R t} \quad (4.14)$$

where the attenuation is now:

$$\hat{\eta}_n = \hat{\omega}_n^I \quad (4.15)$$

To obtain an idea of the relative importance of damping due to shear and rotatory inertia, the attenuations (4.5) and (4.15) have been compared for the following case: Beam of rectangular section

$$l = 40.0'' \quad h = 2.0''$$

Material: Boron fibers, Epoxy matrix

$$v_f = v_m = .5$$

$$E_f = 60 \times 10^6 \text{ psi}, \quad E_m^R = .5 \times 10^6 \text{ psi}, \quad G_m^R = .185 \times 10^6 \text{ psi}$$

$$\tan \delta_E^m = \tan \delta_G^m = \tan \delta_m = .05$$

$$E_A^R = 30.25 \times 10^6 \text{ psi} \quad G_A^R = .544 \times 10^6 \text{ psi}$$

$$\tan\delta_E = \frac{\tan\delta_m}{120}$$

$$\tan\delta_G = \tan\delta_m$$

$$\rho = 1.78 \times 10^{-4} \text{ lb(mass)/in}^3$$

It has been assumed for simplicity that real parts of complex moduli and loss tangents are frequency independent.

For the first mode:

$$\omega_1^R = 1480 \text{ 1/sec}$$

}

Bending only

$$\eta_1 = .308 \text{ 1/sec}$$

$$\hat{\omega}_1^R = 1380 \text{ 1/sec}$$

}

Timoshenko beam

$$\hat{\eta}_1 = 4.44 \text{ 1/sec}$$

It is seen that shear and rotatory inertia have a very small effect on the frequency but increase the attenuation by a factor of 14.4. This example shows that for damping of viscoelastic fiber reinforced beams shear and rotatory inertia are of major importance.

4.2 Forced torsional vibrations of laminated cylinder.

A thin walled cylinder which is laminated through its thickness is built in at one edge and is subjected to a sinusoidal forcing torque at its other edge. Each lamina is uniaxially reinforced and has the same material properties with respect to its material axes. The laminate is symmetric with following lamination scheme:

reinforcement in generator direction (axial) - volume fraction v_0

reinforcement in + θ direction - volume fraction v_{θ}

reinforcement in - θ direction - volume fraction $v_{-\theta}$

$$v_{\theta} = v_{-\theta} \quad (4.16)$$

For the purpose of analysis of torsional vibrations, the only effective laminate property needed is the effective complex shear modulus \tilde{G}_{12}^* . It follows from (3.11) that:

$$\begin{aligned} \tilde{G}_{12}^* = \tilde{C}_{1212}^* = & \text{}^{(0)}\tilde{C}_{1212}t_0/h + \text{}^{(+\theta)}\tilde{C}_{1212}t_{+\theta}/h + \\ & + \text{}^{(-\theta)}\tilde{C}_{1212}t_{-\theta}/h \end{aligned} \quad (4.17)$$

where t_0 is the sum of the thickness of the $\theta=0$ laminae, $t_{+\theta}$ and $t_{-\theta}$ - the sums of the thicknesses of the $+\theta$ and $-\theta$ laminae, respectively.

Now:

$$t_0/h = v_0 \quad (4.18)$$

$$t_{+\theta}/h = t_{-\theta}/h = v_{\theta}$$

and from the last of (3.16)

$$\text{}^{(+\theta)}\tilde{C}_{1212} = \text{}^{(-\theta)}\tilde{C}_{1212} = \text{}^{(\theta)}\tilde{C}_{1212} = \text{}^{(\theta)}\tilde{C}_{44} \quad (4.19)$$

Introduction of (4.18-19) into (4.17) yields

$$\tilde{G}_{12}^* = \text{}^{(0)}\tilde{C}_{44}v_0 + 2\text{}^{(\theta)}\tilde{C}_{44}v_{\theta} \quad (4.20)$$

By the last of (3.16) and from (2.4), (4.20) assumes the form:

$$\tilde{G}_{12}^* = \tilde{G}_A v_0 + \left[\frac{1}{2}(\tilde{n} + \tilde{k} - 2\tilde{l} + \tilde{G}_T) \sin^2 2\theta + 2\tilde{G}_A \cos^2 2\theta \right] v_{\theta} \quad (4.21)$$

It has been mentioned before (Section 2) that the imaginary parts of \tilde{n} , $\tilde{\ell}$ and \tilde{k} can be neglected with respect to the imaginary parts of \tilde{G}_T and \tilde{G}_A for the usual fiber reinforced material. Consequently, the separation of (4.21) into real and imaginary parts assumes the form:

$$G_{12}^{*R} = G_A^R v_0 + \left[\frac{1}{2}(n^R + k^R - 2\ell^R + G_T^R) \sin^2 2\theta + 2G_A^R \cos^2 2\theta \right] v_\theta \quad (a)$$

(4.22)

$$G_{12}^{*I} = G_A^I v_0 + \left(\frac{1}{2} G_T^I \sin^2 2\theta + 2G_A^I \cos^2 2\theta \right) v_\theta \quad (b)$$

In the usual fiber reinforced materials generally

$$\frac{1}{2}(n^R + k^R - 2\ell^R + G_T^R) > 2G_A^R$$

$$\frac{1}{2} G_T^I < 2G_A^I$$

It follows that the shear loss tangent of the laminate

$$\tan \delta^* = \frac{G_{12}^{*I}}{G_{12}^{*R}} \quad (4.23)$$

has a maximum for $\theta=0$ and decreases monotonically to a minimum for $\theta=45^\circ$.

On the other hand shear strength is smallest for $\theta=0$ and increases monotonically to a maximum for $\theta=45^\circ$. Therefore, in design for maximum damping it is necessary to choose the smallest angle θ which complies with allowable shear stress.

Let the forcing torque at the edge $x_1=\ell$ be represented as

$$M = M_0 \sin \omega t$$

and let the amplitude of angle of twist ϕ at $x_1=l$ be written $\text{Amp}(\phi)$.
By standard theory of viscoelastic vibrations with small loss tangents
[2,3]

$$\text{Amp}(\phi) = \frac{cM_o}{JG_{12}^*R\omega} \frac{\sqrt{\sin^2(2\alpha) + \sinh^2(2\beta)}}{\cos(2\alpha) + \cosh(2\beta)} \quad (4.24)$$

where

$$c^2 = \frac{G_{12}^*R C}{\rho J}$$

$$\alpha = \frac{\omega l}{c}$$

$$\beta = \frac{\omega l \delta^*}{2c}$$

ρ - density

C - Torsional constant of section

J - Polar moment of inertia of section

G_{12}^*R - equ. (4.22a)

δ^* - equ. (4.23)

Numerical analysis has been carried out for a laminate composed of boron/
epoxy laminae with both constituent volume fractions equal to .5. Laminae
fractional volumes in laminate are

$$v_o = .6 \quad v_{\pm\theta} = .2 \quad \text{with} \quad \theta = 22.50^\circ$$

Analysis has been performed in following stages:

- (a) Experimental results for epoxy matrix complex shear modulus and loss tangent as a function of frequency have been described by an empirical formula.
- (b) This formula together with elastic properties of fibers have been used to compute effective complex moduli of the uniaxially reinforced laminae,

as a function of frequency. For this purpose results (2.7-9) and other formulae given in [2,3] have been used.

- (c) With the aid of single laminae properties the real and imaginary parts (4.22) of the effective complex shear modulus \tilde{G}_{12}^* have been computed as function of frequency. It should be noted that in the present application 1 indicates generator direction of cylinder, and 2 the direction normal to generator and tangent to section contour.
- (d) The results for G_{12}^{*R} and G_{12}^{*I} have been used to compute (4.24) as a function of frequency ω .

A plot of such results is shown in Fig. 3 for a cylinder of length $l=100$ in. and thin walled circular section. It is seen that the first resonance peak is very significant and may be regarded as an elastic resonance. However, the damping of the viscoelastic matrix becomes more effective with higher order resonances, the fourth one being considerably reduced.

5. Conclusion

It has been shown that complex moduli of uniaxially fiber reinforced materials and of laminates of such materials, consisting of viscoelastic matrix and elastic fibers can be computed in straight forward fashion. The results can be used for analysis of structural vibrations on the basis of available theory.

Two structural examples have been given to assess the significance of vibration damping.

Many more other interesting applications can be analyzed by the theory which has been presented.

References

- (1) Z. Hashin - "Complex moduli of viscoelastic composites - I. General theory and application to particulate composites" Int. J. Solids Structures 6, 539-552, (1970).
- (2) Z. Hashin - "Complex moduli of viscoelastic composites - II. Fiber reinforced materials" Int. J. Solids Structures 6, 797-807, (1970).
- (3) Z. Hashin - "Theory of fiber reinforced materials" Pt. 4, Final Report. Contract NAS 1-8818 NASA, Langley Research Center, Nov. (1970) NASA CR-1974 (1972).
- (4) Y. Stavsky - "Bending and stretching of laminated anisotropic plates" Trans. ASCE, EM Div. 127, Pt. I, 1194-1219, (1962).
- (5) R.M. Christensen - Theory of Viscoelasticity - Academic Press, (1971).
- (6) W. Nowacki - Dynamics of Elastic Systems - Chapman & Hall, (1963).

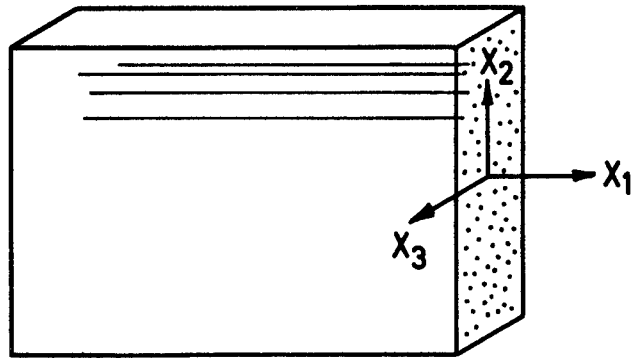

FIG. 1 UNIAXIALLY FIBER REINFORCED MATERIAL

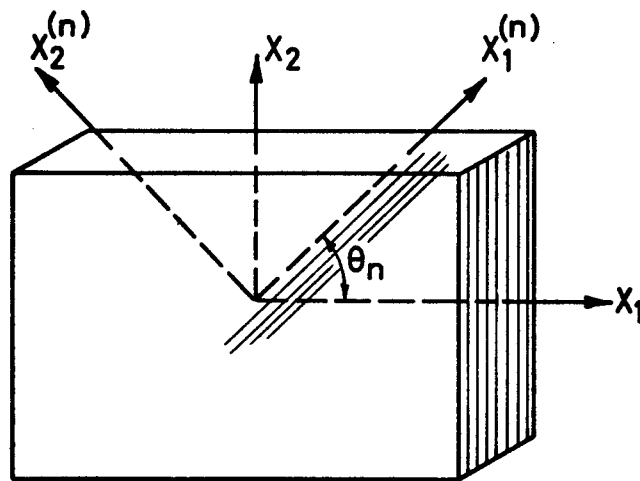

FIG. 2 LAMINATE

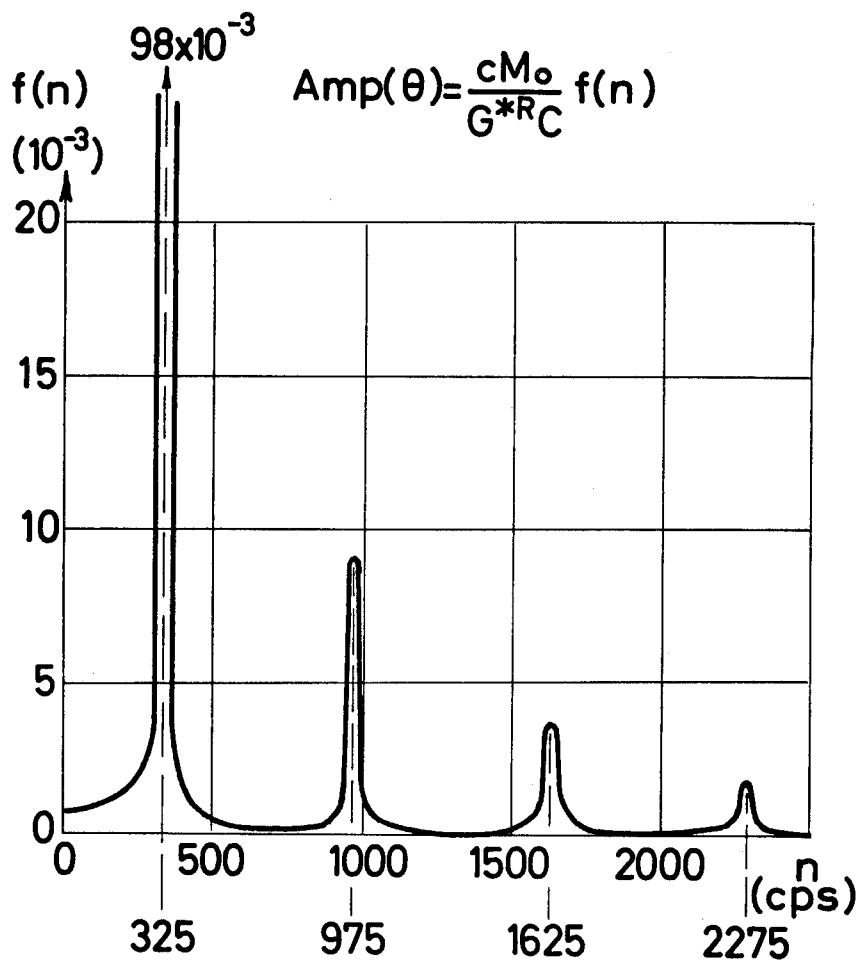

FIG. 3 AMPLITUDE OF ANGLE OF
 TWIST

UNCLASSIFIED

Security Classification

DOCUMENT CONTROL DATA - R&D

(Security classification of title, body of abstract and indexing annotation must be entered when the overall report is classified)

1. ORIGINATING ACTIVITY (Corporate author) Technion Research and Development Foundation Haifa, Israel		2a. REPORT SECURITY CLASSIFICATION Unclassified	
		2b. GROUP	
3. REPORT TITLE DAMPING CHARACTERISTICS OF FIBER COMPOSITES			
4. DESCRIPTIVE NOTES (Type of report and inclusive dates) Scientific Interim			
5. AUTHOR(S) (Last name, first name, initial) HASHIN, ZVI			
6. REPORT DATE July 1972		7a. TOTAL NO. OF PAGES 31	7b. NO. OF REFS 6
8a. CONTRACT OR GRANT NO. F 44620-71-C-0100 b. PROJECT NO.		9a. ORIGINATOR'S REPORT NUMBER(S) MED Report No. 36	
c. d.		9b. OTHER REPORT NO(S) (Any other numbers that may be assigned this report)	
10. AVAILABILITY/LIMITATION NOTICES This document has been approved for public release and sale; its distribution is unlimited.			
11. SUPPLEMENTARY NOTES		12. SPONSORING MILITARY ACTIVITY Air Force Office of Scientific Research 1400 Wilson Blvd. Arlington, Virginia 22209	
13. ABSTRACT <p>Analytical results for complex moduli of uniaxially fiber reinforced materials made of viscoelastic matrix and elastic fibers are reviewed. A general method is established to predict complex moduli and loss tangents of viscoelastic laminates made of uniaxially reinforced laminae. Results are used to analyze some simple cases of vibrations of structures made of such viscoelastic composites.</p>			

14. KEY WORDS	LINK A		LINK B		LINK C	
	ROLE	WT	ROLE	WT	ROLE	WT
Fiber Composites						
Timoshenko Beam						
Laminates						
Torsional Vibrations						
Viscoelasticity						
Complex Moduli						
Loss Tangent						
Damping						
Attenuation						
Flexural Vibrations						

INSTRUCTIONS

1. **ORIGINATING ACTIVITY:** Enter the name and address of the contractor, subcontractor, grantee, Department of Defense activity or other organization (*corporate author*) issuing the report.

2a. **REPORT SECURITY CLASSIFICATION:** Enter the overall security classification of the report. Indicate whether "Restricted Data" is included. Marking is to be in accordance with appropriate security regulations.

2b. **GROUP:** Automatic downgrading is specified in DoD Directive 5200.10 and Armed Forces Industrial Manual. Enter the group number. Also, when applicable, show that optional markings have been used for Group 3 and Group 4 as authorized.

3. **REPORT TITLE:** Enter the complete report title in all capital letters. Titles in all cases should be unclassified. If a meaningful title cannot be selected without classification, show title classification in all capitals in parenthesis immediately following the title.

4. **DESCRIPTIVE NOTES:** If appropriate, enter the type of report, e.g., interim, progress, summary, annual, or final. Give the inclusive dates when a specific reporting period is covered.

5. **AUTHOR(S):** Enter the name(s) of author(s) as shown on or in the report. Enter last name, first name, middle initial. If military, show rank and branch of service. The name of the principal author is an absolute minimum requirement.

6. **REPORT DATE:** Enter the date of the report as day, month, year; or month, year. If more than one date appears on the report, use date of publication.

7a. **TOTAL NUMBER OF PAGES:** The total page count should follow normal pagination procedures, i.e., enter the number of pages containing information.

7b. **NUMBER OF REFERENCES:** Enter the total number of references cited in the report.

8a. **CONTRACT OR GRANT NUMBER:** If appropriate, enter the applicable number of the contract or grant under which the report was written.

8b, 8c, & 8d. **PROJECT NUMBER:** Enter the appropriate military department identification, such as project number, subproject number, system numbers, task number, etc.

9a. **ORIGINATOR'S REPORT NUMBER(S):** Enter the official report number by which the document will be identified and controlled by the originating activity. This number must be unique to this report.

9b. **OTHER REPORT NUMBER(S):** If the report has been assigned any other report numbers (*either by the originator or by the sponsor*), also enter this number(s).

10. **AVAILABILITY/LIMITATION NOTICES:** Enter any limitations on further dissemination of the report, other than those

imposed by security classification, using standard statements such as:

- (1) "Qualified requesters may obtain copies of this report from DDC."
- (2) "Foreign announcement and dissemination of this report by DDC is not authorized."
- (3) "U. S. Government agencies may obtain copies of this report directly from DDC. Other qualified DDC users shall request through _____."
- (4) "U. S. military agencies may obtain copies of this report directly from DDC. Other qualified users shall request through _____."
- (5) "All distribution of this report is controlled. Qualified DDC users shall request through _____."

If the report has been furnished to the Office of Technical Services, Department of Commerce, for sale to the public, indicate this fact and enter the price, if known.

11. **SUPPLEMENTARY NOTES:** Use for additional explanatory notes.

12. **SPONSORING MILITARY ACTIVITY:** Enter the name of the departmental project office or laboratory sponsoring (*paying for*) the research and development. Include address.

13. **ABSTRACT:** Enter an abstract giving a brief and factual summary of the document indicative of the report, even though it may also appear elsewhere in the body of the technical report. If additional space is required, a continuation sheet shall be attached.

It is highly desirable that the abstract of classified reports be unclassified. Each paragraph of the abstract shall end with an indication of the military security classification of the information in the paragraph, represented as (TS), (S), (C), or (U).

There is no limitation on the length of the abstract. However, the suggested length is from 150 to 225 words.

14. **KEY WORDS:** Key words are technically meaningful terms or short phrases that characterize a report and may be used as index entries for cataloging the report. Key words must be selected so that no security classification is required. Identifiers, such as equipment model designation, trade name, military project code name, geographic location, may be used as key words but will be followed by an indication of technical context. The assignment of links, rules, and weights is optional.