



**US Army Corps
of Engineers**

Construction Engineering
Research Laboratories

**USACERL Technical Report 96/16
December 1995**

Evaluation of the Central Heating Plant Operation at Malmstrom Air Force Base, MT

by

Martin J. Savoie
Jill Davidson
Jeri Northrup
Thomas Ask
Charles Schmidt
John Salley
J.W. Chappell

In 1985, a new coal-fired central heating plant was built for Malmstrom Air Force Base (MAFB), MT, to replace the existing poorly operating system and provide for increased heating requirements. Although the generators had been fired intermittently with coal, an unofficial test in March 1986 failed due to plugging in the convective section. To determine the cause of the plugging, the Corps of Engineers' Seattle District asked the U.S. Army Construction Engineering Research Laboratory (USACERL) to observe and document the operation of the heating plant during testing to investigate combustion and design problems.

Operating conditions were corrected and the plant was successfully tested. However, the study found that the design parameters were appropriate for high quality Eastern bituminous coal rather than the subbituminous Western coal available to the plant. It was recommended that the furnace temperature be maintained below the ash fusion temperature of the coal to minimize fouling. The coal supply should be monitored for the presence of hot spots and covered or sealed to prevent drying. Placing an opacity monitor before the baghouse should help operators fine-tune the system using visual readings without taking the generators off line.

19960408 100

DISCLAIMER NOTICE

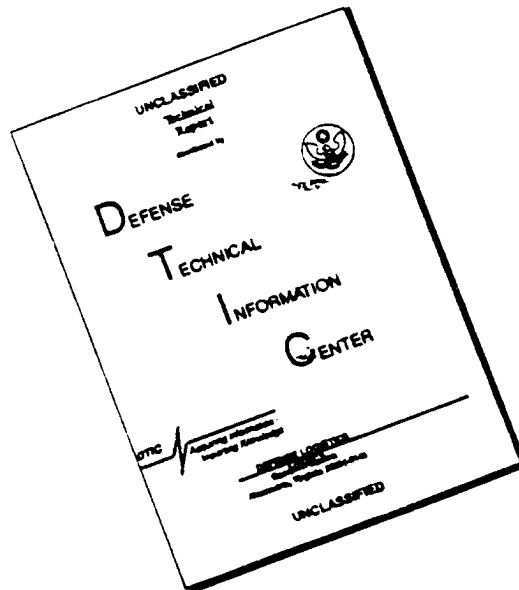

THIS DOCUMENT IS BEST QUALITY AVAILABLE. THE COPY FURNISHED TO DTIC CONTAINED A SIGNIFICANT NUMBER OF PAGES WHICH DO NOT REPRODUCE LEGIBLY.

The contents of this report are not to be used for advertising, publication, or promotional purposes. Citation of trade names does not constitute an official endorsement or approval of the use of such commercial products. The findings of this report are not to be construed as an official Department of the Army position, unless so designated by other authorized documents.

DESTROY THIS REPORT WHEN IT IS NO LONGER NEEDED

DO NOT RETURN IT TO THE ORIGINATOR

USER EVALUATION OF REPORT

REFERENCE: USACERL Technical Report 96/16, *Evaluation of the Central Heating Plant Operation at Malmstrom Air Force Base, MT*

Please take a few minutes to answer the questions below, tear out this sheet, and return it to USACERL. As user of this report, your customer comments will provide USACERL with information essential for improving future reports.

1. Does this report satisfy a need? (Comment on purpose, related project, or other area of interest for which report will be used.)

2. How, specifically, is the report being used? (Information source, design data or procedure, management procedure, source of ideas, etc.)

3. Has the information in this report led to any quantitative savings as far as manhours/contract dollars saved, operating costs avoided, efficiencies achieved, etc.? If so, please elaborate.

4. What is your evaluation of this report in the following areas?

a. Presentation: _____

b. Completeness: _____

c. Easy to Understand: _____

d. Easy to Implement: _____

e. Adequate Reference Material: _____

f. Relates to Area of Interest: _____

g. Did the report meet your expectations? _____

h. Does the report raise unanswered questions? _____

i. General Comments. (Indicate what you think should be changed to make this report and future reports of this type more responsive to your needs, more usable, improve readability, etc.)

5. If you would like to be contacted by the personnel who prepared this report to raise specific questions or discuss the topic, please fill in the following information.

Name: _____

Telephone Number: _____

Organization Address: _____

6. Please mail the completed form to:

Department of the Army
CONSTRUCTION ENGINEERING RESEARCH LABORATORIES
ATTN: CECER-TR-I
P.O. Box 9005
Champaign, IL 61826-9005

REPORT DOCUMENTATION PAGE

Form Approved
OMB No. 0704-0188

Public reporting burden for this collection of information is estimated to average 1 hour per response, including the time for reviewing instructions, searching existing data sources, gathering and maintaining the data needed, and completing and reviewing the collection of information. Send comments regarding this burden estimate or any other aspect of this collection of information, including suggestions for reducing this burden, to Washington Headquarters Services, Directorate for Information Operations and Reports, 1215 Jefferson Davis Highway, Suite 1204, Arlington, VA 22202-4302, and to the Office of Management and Budget, Paperwork Reduction Project (0704-0188), Washington, DC 20503.

| | | | |
|--|---|---|--------------------------------------|
| 1. AGENCY USE ONLY (Leave Blank) | 2. REPORT DATE December 1995 | 3. REPORT TYPE AND DATES COVERED Final | |
| 4. TITLE AND SUBTITLE Evaluation of the Central Heating Plant Operation at Malmstrom Air Force Base, MT | | 5. FUNDING NUMBERS Reimbursable Order No. E87-86-3272 | |
| 6. AUTHOR(S) Martin J. Savoie, Jill Davidson, Jeri Northrup, Thomas Ask, Charles Schmidt, John Salley, and JW Chappell | | | |
| 7. PERFORMING ORGANIZATION NAME(S) AND ADDRESS(ES) U.S. Army Construction Engineering Research Laboratories (USACERL) P.O. Box 9005 Champaign, IL 61826-9005 | | 8. PERFORMING ORGANIZATION REPORT NUMBER TR 96/16 | |
| 9. SPONSORING / MONITORING AGENCY NAME(S) AND ADDRESS(ES) U.S. Army Corps of Engineers, Seattle District ATTN: CENPS-EN-NP/AF PO Box C-3755 Seattle, WA 98124-2255 | | 10. SPONSORING / MONITORING AGENCY REPORT NUMBER | |
| 11. SUPPLEMENTARY NOTES Copies are available from the National Technical Information Service, 5285 Port Royal Road, Springfield, VA 22161. | | | |
| 12a. DISTRIBUTION / AVAILABILITY STATEMENT Approved for public release; distribution is unlimited. | | 12b. DISTRIBUTION CODE | |
| 13. ABSTRACT (Maximum 200 words) <p>In 1985, a new coal-fired central heating plant was built for Malmstrom Air Force Base (MAFB), MT, to replace the existing poorly operating system and provide for increased heating requirements. Although the generators had been fired intermittently with coal, an unofficial test in March 1986 failed due to plugging in the convective section. To determine the cause of the plugging, the Corps of Engineers' Seattle District asked the U.S. Army Construction Engineering Research Laboratory (USACERL) to observe and document the operation of the heating plant during testing to investigate combustion and design problems.</p> <p>Operating conditions were corrected and the plant was successfully tested. However, the study found that the design parameters were appropriate for high quality Eastern bituminous coal rather than the subbituminous Western coal available to the plant. It was recommended that the furnace temperature be maintained below the ash fusion temperature of the coal to minimize fouling. The coal supply should be monitored for the presence of hot spots and covered or sealed to prevent drying. Placing an opacity monitor before the baghouse should help operators fine-tune the system using visual readings without taking the generators off line.</p> | | | |
| 14. SUBJECT TERMS central heating plants Malmstrom AFB, MT | | 15. NUMBER OF PAGES 58 | 16. PRICE CODE |
| 17. SECURITY CLASSIFICATION OF REPORT Unclassified | 18. SECURITY CLASSIFICATION OF THIS PAGE Unclassified | 19. SECURITY CLASSIFICATION OF ABSTRACT Unclassified | 20. LIMITATION OF ABSTRACT SAR |

Foreword

This study was conducted for U.S. Army Corps of Engineers, Seattle District under Reimbursable Order No. E87-86-3272, "Evaluation of Coal and Combustion Problems," dated June 1986. The technical monitor at the start of the project was Richard Woodard, CENPS-EN-NP/AF, and, at the project's completion, John Dornbos, CENPS-EN-NP/AF, and Craig Higgins, CENPS-CO-CS.

The work was performed by the Utilities Division (UL-U) of the Utilities and Industrial Operations Laboratory (UL), U.S. Army Construction Engineering Research Laboratories (USACERL). The USACERL principal investigator was Martin J. Savoie (Chief, CECER-UL-U). John T. Bandy is Operations Chief, CECER-UL and Gary W. Schanche is Chief, CECER-UL. The USACERL technical editor was Gloria Wienke, Technical Resources Center.

COL James T. Scott is Commander and Acting Director, and Dr. Michael J. O'Connor is Technical Director of USACERL.

Contents

| | |
|--|----|
| SF 298 | 1 |
| Foreword | 2 |
| List of Figures and Tables | 5 |
| 1 Introduction | 9 |
| Background | 9 |
| Objectives | 9 |
| Approach | 10 |
| Mode of Technology Transfer | 10 |
| Metric Conversion Factors | 11 |
| 2 Plant Description | 12 |
| Overview | 12 |
| Combustion System Design | 13 |
| Air Pollution Control System Design | 14 |
| Design Fuel | 17 |
| Coal Handling System Design | 19 |
| 3 Capacity and Efficiency Tests | 21 |
| Test Procedures | 21 |
| Official Tests—Gas | 21 |
| Official Tests—Coal | 22 |
| Official Test Summary | 23 |
| Big Horn Coal Tests | 24 |
| Big Horn Test Summary | 25 |
| 4 Slagging and Fouling Considerations | 26 |
| Ash Deposition | 26 |
| Slagging and Fouling Indexes | 27 |
| Slagging and Fouling Research | 31 |
| Grand Forks Energy Data Analysis | 33 |
| Ash Deposition Factors | 46 |
| 5 Conclusions and Recommendations | 49 |
| General Operation | 49 |
| Coal Quality | 49 |
| Stoker/Furnace Design | 50 |

| | |
|--------------------------------|-----------|
| Flyash Reinjection | 50 |
| Overfire Air System | 51 |
| Undergrate Thermocouples | 52 |
| Opacity Monitors | 52 |
| Breeching Duct | 52 |
| Baghouse Design | 52 |
| References | 54 |
| Distribution | |

List of Figures and Tables

Figures

| | | |
|----|---|----|
| 1 | Schematic of high temperature hot water generator | 12 |
| 2 | Plant exterior layout | 13 |
| 3 | Location of burner for natural gas combustion | 15 |
| 4 | Spray dry atomizer | 16 |
| 5 | Schematic of baghouse | 17 |
| 6 | A typical traveling grate spreader stoker | 19 |
| 7 | Coal handling system | 20 |
| 8 | Change in initial deformation temperature under oxidizing and reducing conditions | 30 |
| 9 | Ash deposition model | 32 |
| 10 | Layout of pilot plant test furnace and auxiliary equipment | 34 |
| 11 | Correlation between fouling and volatile organics | 37 |
| 12 | Correlation between fouling and carbon content | 37 |
| 13 | Correlation between fouling and ash content | 38 |
| 14 | Correlation between fouling and sulphur content | 38 |
| 15 | Correlation between fouling and Btu content | 39 |
| 16 | Correlation between fouling and initial temperature | 39 |
| 17 | Correlation between fouling and softening temperature | 40 |
| 18 | Correlation between fouling and flue temperature | 40 |

| | | |
|----|--|----|
| 19 | Correlation between fouling and SiO_2 | 41 |
| 20 | Correlation between fouling and Al_2O_3 | 41 |
| 21 | Correlation between fouling and Fe_2O_3 | 42 |
| 22 | Correlation between fouling and TiO_2 content in ash | 42 |
| 23 | Correlation between fouling and P_2O_5 content in ash | 43 |
| 24 | Correlation between fouling and CaO content in ash | 43 |
| 25 | Correlation between fouling and MgO content in ash | 44 |
| 26 | Correlation between fouling and Na_2O content in ash | 44 |
| 27 | Correlation between fouling and K_2O content in ash | 45 |
| 28 | Correlation between fouling and SO_3 content in ash | 45 |
| 29 | Correlation between the B/A ratio and probe weight | 46 |
| 30 | Correlation between percent NaO_2 in the ash and probe weight | 47 |
| 31 | Correlation between the $\text{Fe}_2\text{O}_3/(\text{CaO} + \text{MgO})$ and probe weight | 47 |

Tables

| | | |
|---|---|----|
| 1 | Design parameters | 14 |
| 2 | SDA design data | 16 |
| 3 | Baghouse design data | 17 |
| 4 | Subbituminous design coal analysis | 18 |
| 5 | Capacity and efficiency test schedule | 21 |
| 6 | Coal ash chemical components | 27 |
| 7 | Slagging and fouling indexes | 28 |
| 8 | Slagging factors and slagging potential | 29 |
| 9 | Effect of iron and calcium on softening temperature | 29 |

| | | |
|----|--|----|
| 10 | Summary of lignites tested at GFETC | 35 |
| 11 | Data on subbituminous and bituminous coals | 36 |

1 Introduction

Background

In 1985, a new coal-fired central heating plant (CHP) was built for Malmstrom Air Force Base (MAFB), MT, to replace the existing poorly operating system and to provide for increased heating requirements. During initial startup procedures, the construction contractor experienced problems operating the system while firing coal. The three traveling grate, spreader stoker, high temperature hot water generators (HTWGs) were to have been designed for Western subbituminous coal. Although the units had been fired intermittently with coal between August 1985 and March 1986, an attempt to achieve 100 percent Maximum Continuous Rating (MCR) during unofficial testing in March 1986 failed. Within 24 hours the convective section was plugged by ash particles, causing an extremely high pressure drop downstream of the HTWG. The unit had to be shut down and the ash buildup in the convective section removed by high pressure hot water lances.

The construction contractor, stoker manufacturer, and the HTWG manufacturer all believed the problem was caused by high percentages of sodium in the coal. Numerous technical journal articles on problems of fouling and slagging caused by high levels of sodium in coal support this idea. The coal burned during this period was from the Big Horn, MT, mine and contained between 2.5 and 4 percent sodium. However, because of the lack of data during this unofficial test, the actual cause of the extreme fouling problem was uncertain. The Corps of Engineers' Seattle District asked the U.S. Army Construction Engineering Research Laboratory (USACERL) to examine the heating plant testing and operation.

Objectives

The objectives of this research were to (1) document the operation of the CHP during official acceptance testing and additional testing to investigate problems stemming from burning Big Horn coal, (2) review the CHP design to identify possible design deficiencies, and (3) make recommendations on operating procedures and fuel supply.

Approach

USACERL representatives kept a daily log or chronology of significant activities and observations from 22 April to 20 June 1986 (Appendix A). During this time, the system was put through pretesting, official acceptance testing, and an unofficial test attempting to reproduce the earlier failure.

During pretest startup, the fireside operation was monitored on all three HTWGs. Monitored parameters included overfire air pressure, generator outlet gas temperature, and generator outlet gas oxygen content. Qualitative parameters of fuel bed thickness, bottom ash burnout, clinkering, and flyash burnout were also monitored. During official capacity and efficiency tests, efficiency calculations were made using American Society of Mechanical Engineers (ASME) Performance Test Code (PTC) 4.1 efficiency test procedures. The results were cross-checked with contractor's calculations.

Because initial firing problems of the HTWGs were blamed on poor quality coal, the official performance, capacity, and operational tests were conducted using a higher quality coal than originally specified. However, to determine the performance, capacity, and reliability of the HTWGs firing a lower quality coal (closer to the design specifications), one HTWG was tested while being fired with high sodium content coal. The coal was from the same mine (Big Horn) as the coal burned during the forced shutdown in March 1986.

In addition to the combustion system operating evaluations, an onsite evaluation of the heating plant facilities was made and heating plant drawings were reviewed to identify possible design flaws that could cause poor equipment performance and operational problems.

Mode of Technology Transfer

It is recommended that the results of this report be used as background information for updating criteria documents on planning, designing, and testing of coal-fired heating systems. Documents that could be affected by the results of this project include Air Force Manual (AFM) 85-12, *Operation and Maintenance of Central Heating Plants*; Technical Manual (TM) 5-810-2 and Air Force Regulation (AFR) 88-28, *High Temperature Water Heating Systems*; TM 5-651, *Central Boiler Plant Inspection and Preventive Maintenance Systems*; TM 650, *Repairs and Utilities Preventive Maintenance for Heating Plant Systems*, and TM 5-810-15, *Design of Coal-Fired Boiler Plants*.

Metric Conversion Factors

U.S. standard units of measure are used throughout this report. A table of metric conversion factors is presented below.

| | | |
|-----------|---|---------------------------|
| 1 in. | = | 25.4 mm |
| 1 ft | = | 0.305 m |
| 1 sq ft | = | 0.093 m ² |
| 1 lb | = | 0.453 kg |
| BTU | = | 1054.8 J |
| BTU/sq ft | = | 11,348.9 J/m ² |
| °F | = | (°C × 1.8) + 32 |

2 Plant Description

Overview

The Seattle District was the contracting agency for the MAFB central heating plant. They monitored the design, construction, and acceptance of the new plant. Stanley Consultants developed the design package and Brinderson Corporation was the prime construction contractor. Appendix B lists the equipment specifications. The CHP consists of three traveling grate, spreader stoker, HTWGs. Figure 1 shows a schematic of the flue gas side of an individual generator.

The HTWGs were designed by International Boiler Works (IBW) and the stokers by Detroit Stoker. Units 1 and 2 are equipped to burn both coal and natural gas using Coen Company burners. Each unit is also equipped with a Ljungstrom type air heater made by C-E Air Preheater. Each unit has a multicyclone mechanical collector made

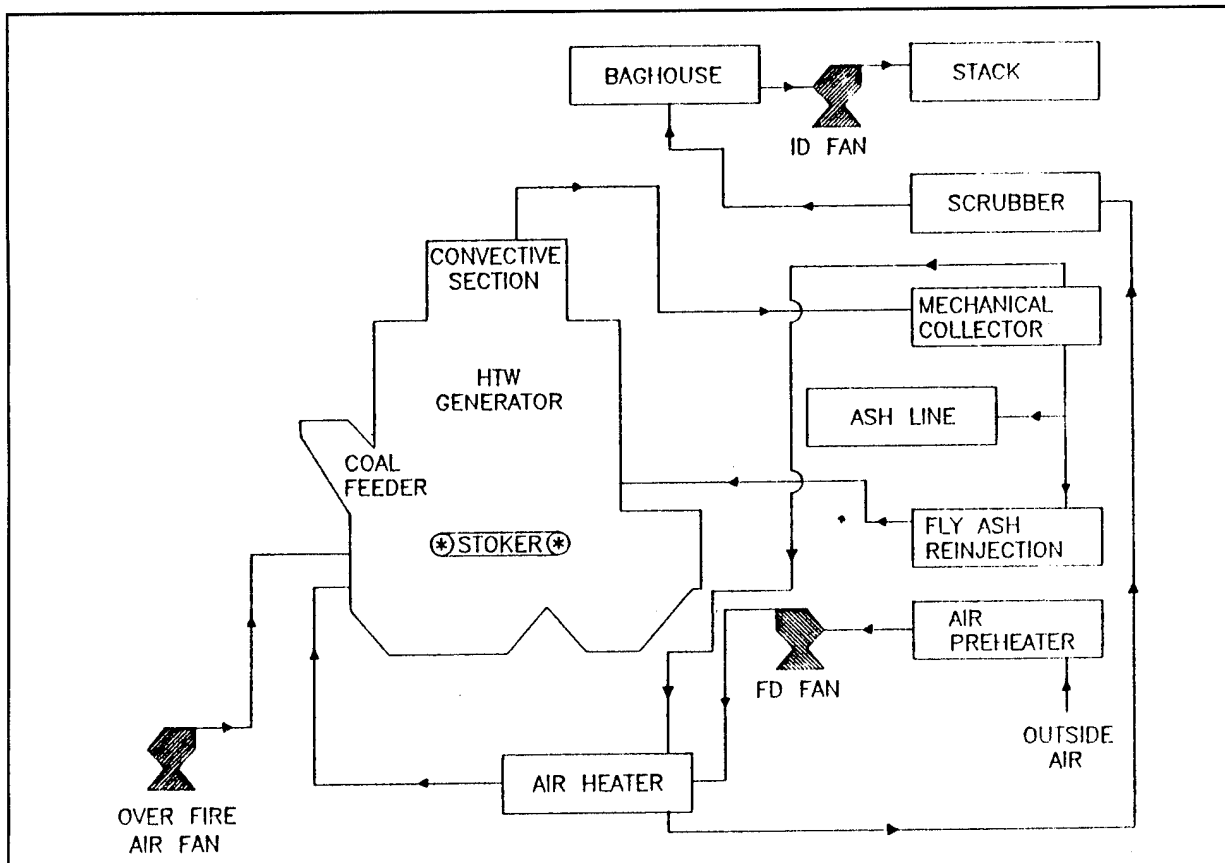

Figure 1. Schematic of high temperature hot water generator.

by Enviro Systems & Research, Inc. for flyash control. The CHP has a state-of-the-art sulfur oxide (SO_x) removal system, called a spray dry absorber (SDA), manufactured by the Niro Corporation. The SDA is followed by a conventional reverse-air baghouse made by Joy Manufacturing for particulate collection. Figure 2 shows the exterior plant layout.

Combustion System Design

The primary fuel for these units is coal; natural gas is a secondary fuel for summer operation of Units 1 and 2. Table 1 gives basic design and operating data. When natural gas is fired, an auxiliary induced draft fan is used and the primary air pollution control devices are bypassed. The burner at the center of the furnace back wall is removed during coal combustion. Figure 3 shows where the burner would be located during natural gas combustion.

Current operation uses coal for winter operation only. Coal is fed from the stoker hoppers to three feeders that rotate and throw the coal over the grate. The fine coal is burned in suspension while the larger lumps fall onto the grate, form a thin fuel bed, and burn. Between 30 and 40 percent of the coal is burned in suspension. Because of this, spreader stokers can respond to rapidly changing loads.

Primary combustion air is drawn from outside the plant through an air preheater by a forced draft fan. The air is heated by passing it through a loop from the hot water distribution system. The combustion air is further heated by flue gas passing through

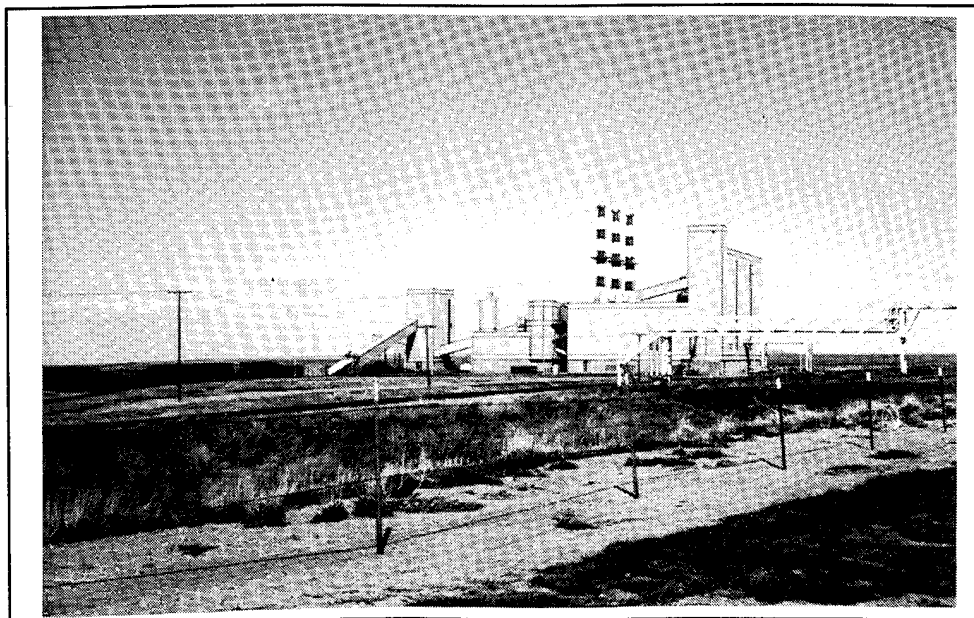

Figure 2. Plant exterior layout.

Table 1. Design parameters.

| Parameter | Units | Design |
|---|-----------------------|------------|
| Generator continuous output capacity (coal-fired) | Btu/h | 85,000,000 |
| Generator continuous output capacity, gas firing (units 1 and 2 only) | Btu/h | 30,000,000 |
| Design pressure (water side) | psig | 500 |
| Outlet temperature (water side) | °F | 414 |
| Return temperature (100% load, water side) | °F | 305 |
| Efficiency (100% load) | % (minimum) | 80 |
| Furnace exit gas temperature | °F (maximum) | 1850 |
| Furnace volume* | cu ft (minimum) | 3600 |
| Furnace input release rate | Btu/h/cu ft (maximum) | 30,000 |
| Grate input release rate | Btu/h/sq ft (maximum) | 700,000 |
| Turndown ratio | — | 3:1 |

* Furnace volume is defined as the volume in the primary furnace bounded by the stoker grate, the water walls, and the first row of screen tubes.

a Ljungstrom Air Heater. It is then introduced under the combustion grates, which are designed to promote air distribution. Operating with a thick ash bed improves air distribution. Overfire air is provided by a separate fan and is introduced at both the back and front walls of the furnace. Each wall has an upper and lower row of overfire air ports. Overfire air creates turbulence in the furnace chamber to improve combustion of coal particles.

The hot flue gas leaves the furnace chamber and passes through a tube bank or convective section to transfer heat from the flue gas to the water in the tubes. Once past the convective section, the cooler gas flows through a multiple cyclone flyash collector to remove large ash particles. About 50 percent of this ash is reinjected into the furnace for further combustion (Figure 1). The balance enters the ash handling system. The flue gas then passes through the Ljungstrom Air Heater that heats the primary combustion air. This increases the combustion efficiency and controls the temperature entering the SDA.

Air Pollution Control System Design

After the flue gas exits the air heater, it enters the SO_x control device, or SDA (Figure 4). Each HTWG unit has its own SDA that consists of a rotary atomizer for introducing a wet SO_x-absorbing material and a reaction vessel for mixing and drying the flue gas. The rotary atomizer spins the absorbing material at 3600 revolutions per

minute (RPM) to create a fine mist to react with the entering flue gas. Important design parameters for this system are the gas flow rates at the spray dryer inlet and outlet, and temperatures at the inlet and outlet. Table 2 shows a partial list of the SDA design data provided by the contractor. The inlet flow rate and temperature are important in the chemical reaction that removes SO_x. The outlet temperature and flow rate are important to operation of the baghouse that follows the SDA.

Each HTWG unit has its own five-compartment, reverse-air baghouse (Figure 5). Flue gas enters vertically hung cylindrical bags (120 per compartment) that are 8 in. in diameter and about 22 ft long. A filter cake of ash and scrubber material collect on the inside of the bags. When the pressure drop exceeds a specified value, the cleaning cycle is initiated.

Cleaning is done by isolating a compartment from the induced draft fan and reversing the airflow through the bags with a smaller fan. The bags collapse slightly to dislodge the filter cake that falls into a hopper below the bags. The cleaned compartment is brought back online and another is taken offline until the cycle is complete.

Table 3 shows a partial list of the baghouse design data provided by the contractor. The baghouse is designed to operate at continuous gas temperatures up to 500 °F. High temperature excursions that could damage the bags are unlikely in this system. However, low temperatures could cause the flue gas to drop below its dewpoint causing condensation to form on the bags. This would "blind" the bags, causing a high pressure drop and requiring increased cleaning cycles. Severe blinding could require total bag replacement.

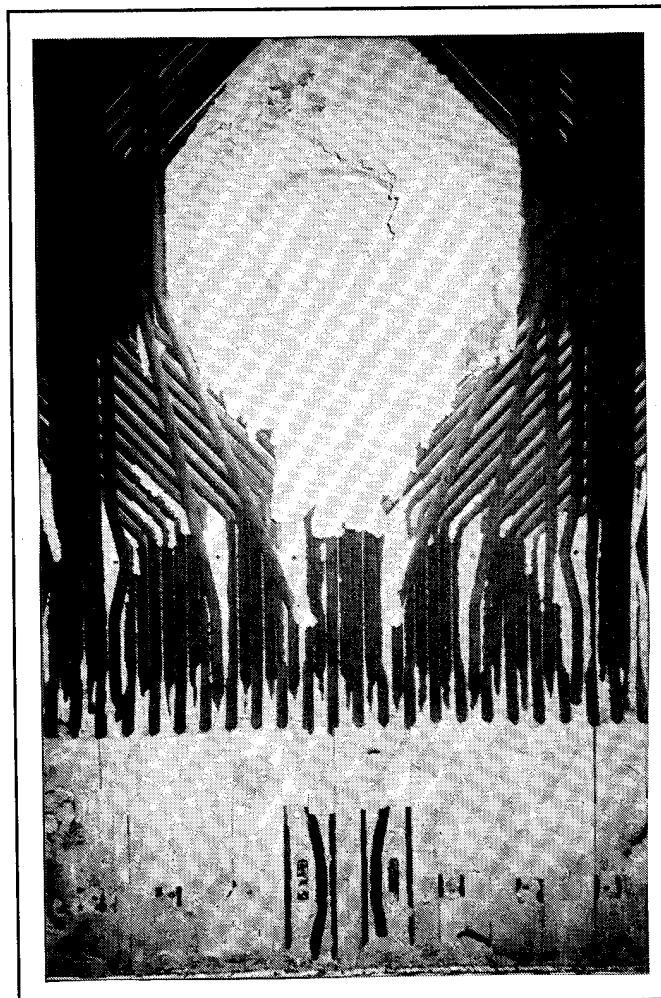

Figure 3. Location of burner for natural gas combustion.

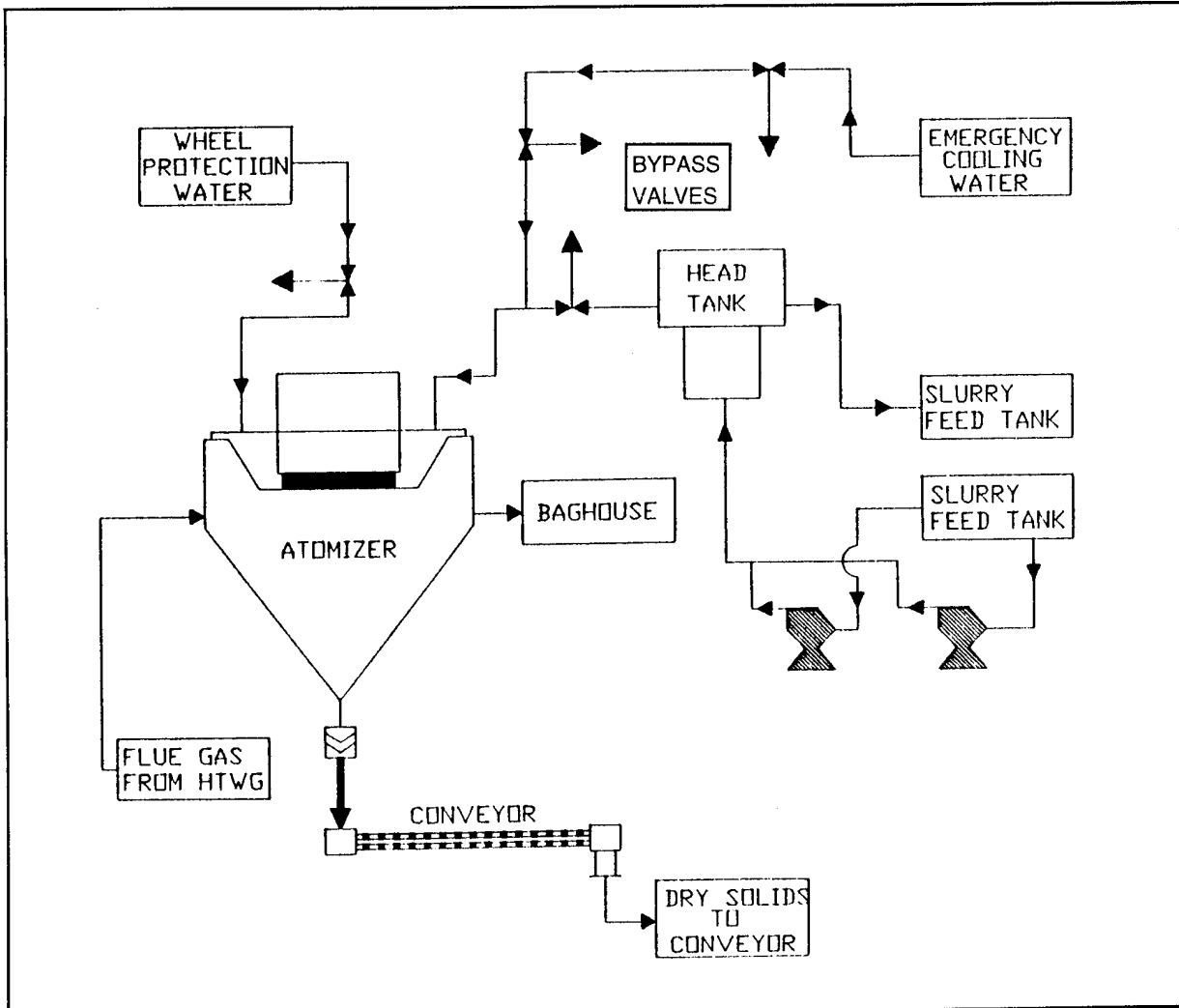

Figure 4. Spray dry atomizer.

Table 2. SDA design data.

| Parameter | Value |
|--|--------------|
| Inlet flue gas flow rate (max) | 119,100 lb/h |
| Outlet flue gas flow rate | 125,700 lb/h |
| Inlet temperature | 324 °F |
| Outlet temperature | 161 °F |
| Inlet SO ₂ | 2.00 lb/MBtu |
| Outlet SO ₂ (from baghouse) | 0.28 lb/MBtu |

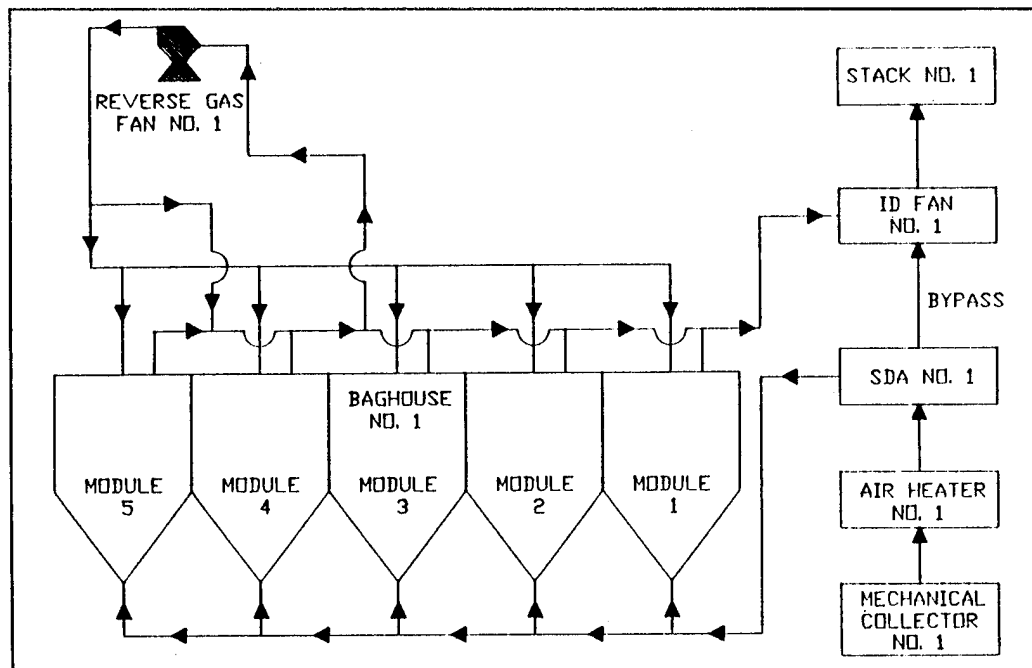

Figure 5. Schematic of baghouse.

Table 3. Baghouse design data.

| Parameter | Value |
|---------------------------------------|--------------|
| Inlet flue gas flow rate | 125,700 lb/h |
| Inlet temperature | 161 °F |
| Outlet temperature | 151 °F |
| Bag temperature (continuous) | 500 °F |
| Bag temperature (short duration, max) | 500 °F |

Design Fuel

The design fuel is as important as any equipment specification for stoker-fired systems. Although there is little variation in the quality of natural gas, coal quality can vary greatly. Traveling grate spreader stokers are particularly sensitive to the coal's size distribution, ash content, and volatile matter. Table 4 shows the coal quality requirements specified in the design criteria for the MAFB central heating plant. Size distribution is very important in spreader stokers because the coal particles must be spread evenly on the grate. The fuel must contain a certain

Table 4. Subbituminous design coal analysis.

| Parameter* | Minimum | Range |
|---|---------|-----------|
| Proximate Analysis (as received) | | |
| Btu High Heating Value (HHV) | 9400 | 8500-9900 |
| Water | 25 | 20-28 |
| Ash | 10 | 7-11 |
| Volatile matter | 30 | 25-35 |
| Fixed carbon | 35 | 30-40 |
| Total | 100 | |
| Ultimate Analysis | | |
| Carbon | 53.0 | |
| Hydrogen | 3.5 | |
| Nitrogen | 1.0 | |
| Oxygen | 6.5 | |
| Sulfur | 1.0 | |
| Ash | 10.0 | |
| Water | 25.0 | |
| Total | 100.0 | |
| Ash Fusion | | |
| Softening Temperature, °F | 2100 | 2100-2400 |
| Size: - 1 1/4" Maximum Top Screen Size - 3/4" Minimum Top Screen Size with Maximum 40 percent through 1/4" screen | | |
| * All parameters except Btu HHV are percentages. | | |

percentage of coal in several size ranges. If the coal sizing is incorrect, the bed will not be even. Clinkering will occur at the thick spots and combustion air will flow through the thin spots without participating in the combustion process. Either case can also increase ash loading on downstream equipment. Figure 6 shows the coal feeding method for a typical traveling grate spreader stoker.

The ash in coal helps provide an even distribution of air under the fuel bed. Without a sufficiently high ash content, the combustion air can blow holes through the fuel bed. A thick ash bed also protects the grate from overheating by acting as an insulator.

Volatile matter in coal consists of hydrogen, carbon monoxide, methane, and sulfur compounds given off as gases during decomposition of coal when heated. These gases are highly combustible and make it easier for coal to ignite. This is important because 30 to 40 percent of the coal in spreader stokers is burned in suspension.

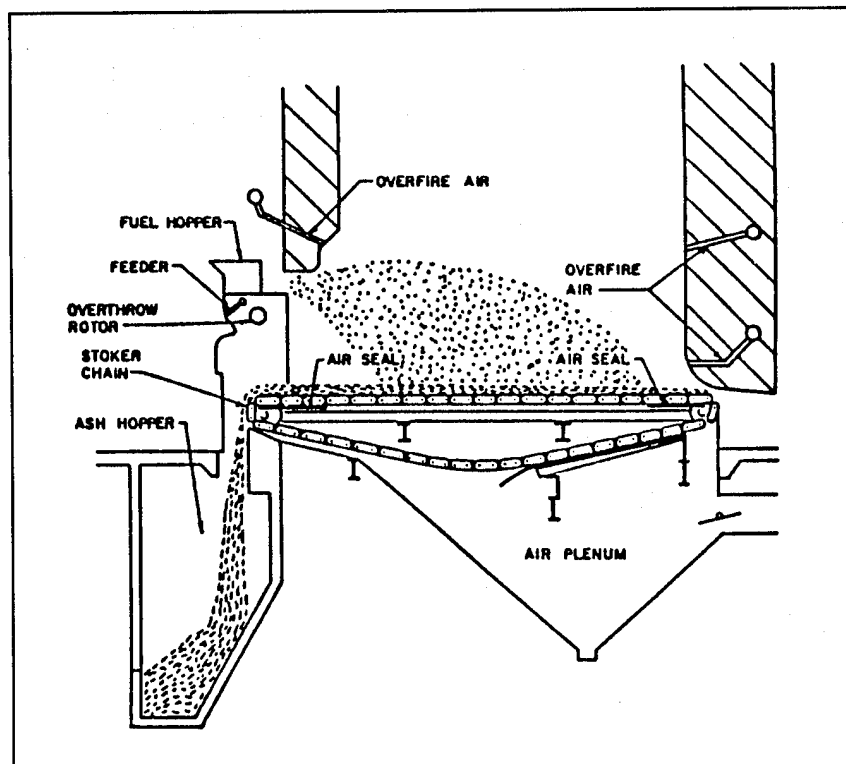

Figure 6. A typical traveling grate spreader stoker.

Coal Handling System Design

Figure 7 shows a flow diagram of the MAFB coal handling system. It is a typical system where coal is delivered to the CHP by truck or rail car and moved to either in-plant storage for firing or to an outside storage pile. A carhoe, which is similar to a backhoe and is operated manually from a seat above the rail car, is used to encourage flow from the rail cars. Coal is unloaded from the rail cars into an undertrack receiving hopper and is then fed to a nearby transfer house by belt conveyor. Coal delivered by truck is received at a second underground hopper which also serves as a reclaim hopper for the outside storage pile. Coal is also fed from this hopper to the transfer house by belt conveyor.

At the transfer house, coal can continue to the CHP for firing or be loaded in trucks or onto the ground to be moved by a rubber-tired loader to the outside storage pile. Coal is moved to the CHP by belt conveyor and is transferred onto an overbunker flight conveyor. This conveyor drops coal through gates at different locations in a long bunker. The bunker is rectangular and contains three hoppers shaped like inverted pyramids. Each hopper feeds a boiler via an electronic scale. An underbunker flight conveyor can be used to transfer coal from any hopper to any boiler. After being weighed, the coal is gravity fed to the boiler through an inclined chute and distributed

to the three spreaders by a conical bottom, nonsegregating distribution chute. The entire coal handling system, including the overbunker gates, is controlled from the main operating floor with the plant's Bailey Network 90 direct digital control system.

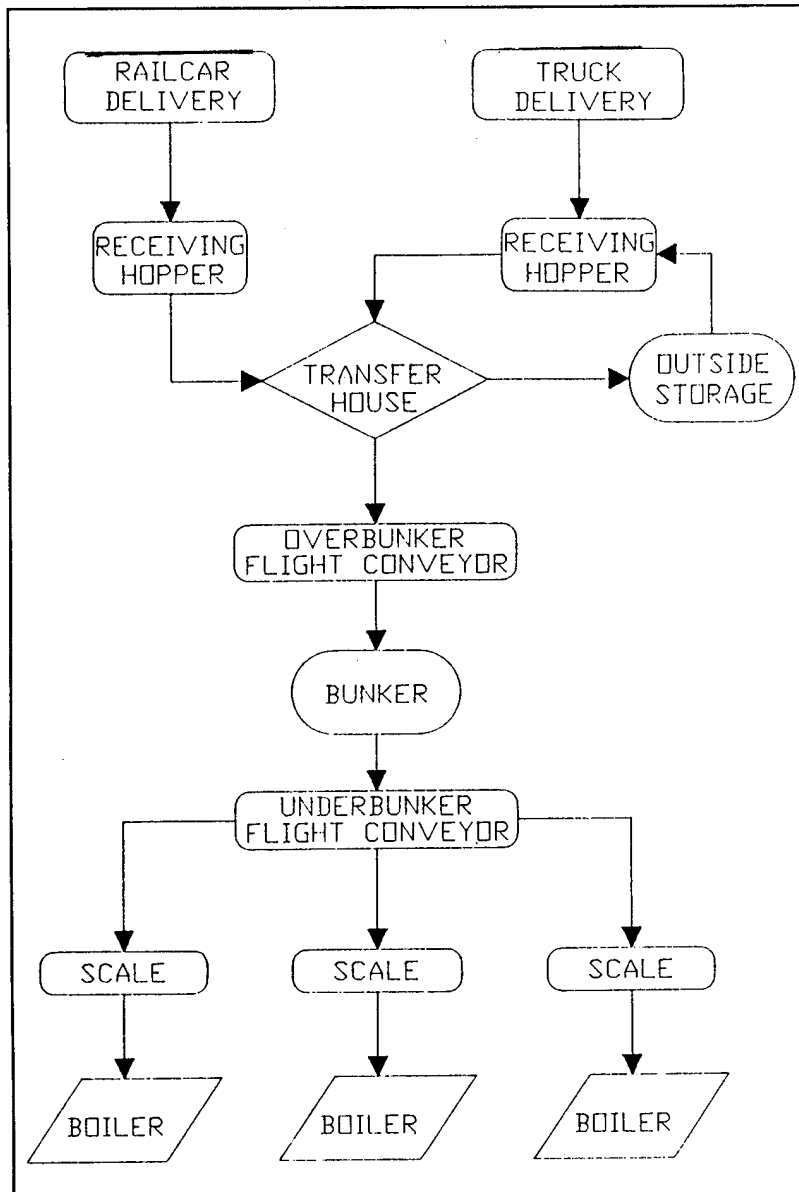

Figure 7. Coal handling system.

3 Capacity and Efficiency Tests

Test Procedures

Two sets of capacity and efficiency tests were performed during this project. The first set was the official tests performed by IBW to determine if the HTWGs met the operational requirements of the Seattle District Corps of Engineers. The second set of tests was performed by USACERL to document HTWG performance during initial startup with a high sodium content coal from the Big Horn mine.

Testing was conducted in accordance with the ASME Performance Test Code, Section 4.1 Abbreviated Efficiency Test for high temperature water generators. The HTWG efficiencies were determined by the heat loss method described in the Performance Test Code. Official capacity and efficiency test data and calculations from both IBW and USACERL are contained in Appendix C. Big Horn coal capacity and efficiency test data and calculations from USACERL are contained in Appendix D.

Before each test run was started, the HTWG was brought to test load and operated for at least 1 hour to stabilize temperatures, pressures, and air flows. Each coal-fired test lasted 10 hours; each gas-fired test lasted 4 hours. Table 5 shows the unit tested, date, and fuel used. Note that HTWG # 3 is designed to burn coal only.

Official Tests—Gas

The test results of the HTWGs while burning gas were a secondary concern for this project, but are reported here for completeness. HTWGs #1 and #2 are required by Corps of Engineers' specifications to meet an 80 percent thermal efficiency at 30 MBtu output while burning natural gas.

Table 5. Capacity and efficiency test schedule.

| Unit Tested | Date | Fuel |
|---------------------------|--------------|-------------|
| <i>Official Tests</i> | | |
| Generator No. 1 | 21 May 1986 | Coal |
| Generator No. 1 | 3 June 1986 | Natural gas |
| Generator No. 2 | 12 May 1986 | Coal |
| Generator No. 2 | 2 June 1986 | Natural gas |
| Generator No. 3 | 27 May 1986 | Coal |
| <i>Big Horn Coal Test</i> | | |
| Generator No. 2 | 19 June 1986 | Coal |

The capacity test on HTWG #1 burning natural gas was performed at 31.4 MBtu heat output. IBW calculations showed an 80.70 percent thermal efficiency assuming no unmeasured loss. USACERL calculations showed a 81.94 percent thermal efficiency assuming no unmeasured loss. This discrepancy occurred because IBW used a fuel analysis from July 1986 and USACERL used a September 1986 analysis. It is also standard practice to assume an unmeasured loss and subtract it from the thermal efficiency. According to the American Boiler Manufacturers Association (ABMA), this loss is a maximum of 1 percent for natural gas. Subtracting this from the 81.94 percent thermal efficiency determined by USACERL gives a 80.94 percent thermal efficiency, exceeding the contractor's guarantee of 80 percent.

The capacity test on HTWG #2 burning natural gas was performed with the generator operating at 29.0 MBtu heat output. IBW calculations show an 80.93 percent thermal efficiency with no unmeasured loss. USACERL calculations showed a 82.75 percent thermal efficiency assuming no unmeasured loss. Correcting for the 1 percent unmeasured loss gives a 81.75 percent thermal efficiency, again exceeding the contractor's guarantee of 80 percent.

Official Tests—Coal

The capacity test conducted by IBW on HTWG #1 burning coal was performed with the generator operating at 84.9 MBtu heat output. IBW calculations show an 85.45 percent thermal efficiency using a 3.07 percent carbon loss and 0.50 percent unmeasured loss. The most accurate method to calculate carbon loss is to perform a material balance, which consists of weighing all material entering and leaving the boiler and conducting an ultimate analysis of that material. This was not required by the Seattle District, so the standard ABMA carbon loss curves were used. The problem with using these curves is that the evaluator needs an estimate of how much flyash is reinjected from the mechanical collectors back into the furnace. The ash from this system is split, part going to the furnace and part going to the ash handling system. Contractor representatives did not know how much ash was designed to go back to the furnace. To be conservative, USACERL calculated what the carbon loss would be if reinjection did not occur. Using the ABMA carbon loss curve at zero percent recovery, the carbon loss would be 5.70 percent.

In addition, the unmeasured loss of 0.50 percent used by IBW should be 1.50 percent as stated in *Combustion Engineering, A Reference Book on Fuel Burning and Steam Generation* (Riverside Press, 1949). Applying these two corrections to the test data results in a minimum efficiency of 81.82 percent, which still surpasses the guarantee

of 80 percent thermal efficiency. There were no other discrepancies between USACERL and IBW calculations.

USACERL monitored the convective section inlet (furnace outlet) temperature on HTWG #1 to ensure compliance with the Corps of Engineers' specification of a maximum temperature of 1850 °F. The temperature during this test ranged from 1664 to 1880 °F with only 1 reading out of 19 over 1850 °F.

The capacity test on HTWG #2 burning coal was performed with the generator operating at 84.76 MBtu heat output. IBW calculations show an 84.76 percent thermal efficiency using a 5.64 percent carbon loss and 0.50 percent unmeasured loss. USACERL calculations show a 4.75 percent carbon loss, assuming no ash reinjection from the mechanical collector. As stated above, the unmeasured loss should be 1.50 percent. Correcting the carbon loss and the unmeasured loss results in a minimum efficiency of 84.65 percent, well above the 80.00 percent guarantee. The convective section inlet (furnace outlet) temperature on HTWG #2 was not monitored during this test.

The capacity test on HTWG #3 burning coal was performed with the generator operating at 89.4 MBtu heat output, or 105 percent of rated capacity. IBW calculations show an 84.13 percent thermal efficiency using a 4.44 percent carbon loss and 0.50 percent unmeasured loss. USACERL calculations show a 5.89 percent carbon loss, assuming no ash reinjection from the mechanical collector. Again, the unmeasured loss should be 1.50 percent. Correcting the carbon loss and the unmeasured loss results in a minimum efficiency of 81.78 percent, still above the 80.00 percent guarantee.

The convective section inlet (furnace outlet) temperatures ranged from 1735 to 1830 °F, with 2 readings out of 17 over 1800 °F.

Official Test Summary

Overall, the official capacity and efficiency tests were quite successful. In addition to meeting thermal efficiency requirements, all HTWGs met the specifications for grate and furnace heat release rates. The grate heat release rates for all coal tests were calculated to be from 630,397 to 693,950 Btu/sq ft/h, all below the specified 700,000 Btu/sq ft/h. The furnace heat release rate was guaranteed to not exceed 30,000 Btu/cu ft/h of furnace volume. Test calculations show the heat release rates to be from 27,597 to 30,380 Btu/cu ft/h, the highest being with Generator #3 operating at 89.44 MBtu/h output or 105 percent of rated capacity. Combustion data gathered by USACERL

personnel and contractors uncovered sensor problems that had contributed to the earlier operational problems.

Big Horn Coal Tests

The purpose of this test was to substantiate or disclaim the problems encountered by Brinderson operators during initial startup in March 1986, using coal from the Big Horn mine. In an unofficial test to achieve 100 percent MCR, the convective section was plugged by ash particles causing an extremely high pressure drop downstream of the HTWG. The HTWG had to be shut down and the ash buildup removed by high pressure hot water lances.

The contractor's explanation for this plugging or fouling problem focused on the sodium content of the coal. The presence of high levels of certain minerals, especially sodium, can increase the chances of fouling. (A detailed explanation of this phenomenon is given in Chapter 4.) The Big Horn coal was reputed to have as high as 6 percent sodium content, although the only reports available showed the sodium content to be between 2.5 and 4.0 percent.

USACERL personnel and contractors recorded all data necessary for the ASME Performance Test Code calculations. Additional data were recorded to determine furnace outlet temperatures and mechanical collector outlet flue gas velocities. Temperature is an important parameter in fouling. The flue gas velocities are important to the operation of the SDA.

JW Chappell, a representative of Schmidt and Associates, Inc., instructed operators on stoker settings and adjustments throughout the test. The fuel bed thickness was difficult to control because of the low ash content of the coal (3.5 to 3.8 percent). A thick ash bed is necessary to control excess air, flyash carryover, and to protect grates from overheating. Chappell was able to help the operators achieve a bed depth of 4 to 5 in. for the test.

Because of the suspected quality of the Big Horn coal, Brinderson Corporation sent samples to Commercial Testing and Engineering Company and the Seattle District Corps of Engineers sent samples to Northern Engineering & Testing, Inc., for analyses. Results of the analyses are almost identical and are contained in Appendix D. The sodium content was 1.70 to 1.75 percent. Before the test, the Big Horn coal was sized using portable sizing equipment to ensure a maximum of 40 percent fines at the stoker feeders. This was necessary because the coal was very friable and had broken down from exposure to weather over the previous 3 months.

Big Horn Test Summary

The results of the test show a thermal efficiency of 79.94 percent with zero percent flyash reinjection, based on Northern Engineering's coal analysis. The thermal efficiency based on Commercial Testing's coal analysis was 80.13 percent with zero percent recovery. Furnace heat release rates were calculated from 29,229 to 29,298 Btu/cu ft/h while grate heat release rates range from 667,664 to 669,251 Btu/sq ft/h. Furnace exit gas temperatures were measured from 1650 to 1730 °F, the average being 1689 °F. Oxygen content at the mechanical collector outlet/air heater inlet test ports averaged 4.1 percent. The flue gas between the mechanical collector outlet and air heater inlet averaged 467 °F and 111,590 lb/h. The temperature of the flue gas leaving the air heater averaged 328 °F with the flue gas flow averaging 129,288 lb/h. The convection section pressure drop and furnace exit flue gas temperature remained constant during the test, with no signs of fouling visible through the observation ports. The test data confirmed acceptable operation of the HTWG using Big Horn coal, with the exception of the flue gas flow rate.

The flue gas flow rate at the convective section outlet was predicted to be 105,130 lb/h at 100 percent MCR. The flow rate measured at the mechanical collector, which is just downstream of the convective section, showed a flow rate of 111,590 lb/h. More important is the flue gas flow rate exiting the air heater, because it exceeds the design limits of the SDA. The maximum design flow rate through the SDA is 119,100 lb/h, but it was 129,288 lb/h during the test. The jump from 111,590 to 129,288 lb/h would appear to indicate that there is a major leak in the air heater. This problem was not apparent during the official tests. If the SDA cannot operate effectively with the higher flow rates, the unit would have to operate at a lower capacity.

After the test, the generator was immediately taken off line and allowed to cool for inspection the following day. Inspection of the generator outlet duct showed a fine dust buildup similar to that found after previous tests. A small amount of slag had formed around the gas burner cover plate, but there was no visible indication of fouling in the convection section.

With experienced stoker operators, a high sodium content coal can be burned without affecting the performance of the generator. Inexperienced operators would have a difficult time firing the Big Horn coal, although the difficulty would be because of the ash content not the sodium content. The problems in March 1986 most likely occurred because of high primary airflow and because the insufficient fuel bed depth had caused particle carryover and high furnace exit temperature conditions, resulting in slag formation and convection section plugging.

4 Slagging and Fouling Considerations

The use of coal to produce steam in industrial sized boilers has fallen out of favor in the past 25 years because of environmental restrictions that have been placed on coal burning facilities. The Department of Defense has been directed by Congress to return to coal as the fuel of choice whenever possible. This means that the art of firing coal must be learned by new operators. Some of the operating problems associated with industrial sized coal burning facilities can be solved by careful attention of the operator to the combustion process and by understanding how coal properties affect combustion. This chapter discusses what slagging and fouling are and why they occur.

Ash Deposition

Ash is the incombustible residue left when coal is burned. One common operating problem when burning coal is the formation of ash deposits on tube surfaces inside the furnace box and convective sections. Deposits on tubes reduce heat transfer to the boiler tubes, reducing boiler efficiency. Ash deposits can also cause corrosion, restrict secondary air flow, and increase ash handling. Sodium, potassium, and iron have been linked to deposit formation in the furnace and boiler tube banks.

Mineral matter has a profound effect on the performance of the combustion system. It affects the coal's ash fusibility, which is the gradual softening and melting of the ash. The temperatures at which ash reaches certain defined stages of fusion and flow are collectively defined as the ash fusion temperature. Both the ash fusion temperature and the coal's mineral content affect slagging and fouling.

Deposits in the furnace area are called slagging and deposits in the convective section are called fouling. Slagging is a buildup of molten ash on refractory walls and tubes that can be removed easily and often falls off during operation. Fouling is a bonding of volatilized minerals to tube surfaces. It is very difficult to remove and sometimes requires acid cleaning.

Slagging and Fouling Indexes

A more technical differentiation between slagging and fouling, called the Slagging Index and Fouling Index, is determined by the chemical makeup of the coal ash. To assess the amounts of the major elements present in coal, an analysis is made to determine the percentages of the oxides of these elements present in the coal ash. The mineral constituents of coal are very widespread. Table 6 lists the most prominent coal ash chemical constituents and their percentage range. As can be seen by the ranges in the oxides of the components, there is no "typical" coal ash analysis. However, general principals can be deduced from the relative quantities of various chemical constituents. Among these are the following parameters:

- base/acid ratio
- iron/calcium ratio
- silica/alumina ratio
- iron/dolomite ratio
- ferric percentage
- silica percentage
- total alkalies.

To use the information obtained from a complete chemical analysis of the ash, the type of ash present needs to be determined. There are two general categories of ash—bituminous and lignitic—that are not necessarily related to the rank of the coal. The following definitions apply to lignitic and bituminous ashes:

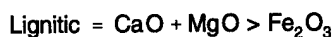

The slagging and fouling potential of a coal can be estimated by considering the base/acid ratios (for bituminous coals) and the ash fusion temperatures (for lignitic coals). The constituent parameters are defined below. The discussions include the numerical values that define the slagging and fouling potential for each parameter.

Table 6. Coal ash chemical components.

| Component | Range (in percent) |
|--------------------------------|--------------------|
| SiO ₂ | 10 - 70 |
| Al ₂ O ₃ | 8 - 38 |
| Fe ₂ O ₃ | 2 - 64 |
| CaO | 0.3 - 24 |
| MgO | 0.1 - 8 |
| Na ₂ O | 0.1 - 8 |
| K ₂ O | 0.1 - 3 |
| TiO ₂ | 0.4 - 3.5 |
| SO ₃ | 0.1 - 30 |

Base/Acid (B/A) Ratio

The Base/Acid (B/A) ratio is defined as:

$$\frac{B}{A} = \frac{\text{Fe}_2\text{O}_3 + \text{CaO} + \text{MgO} + \text{Na}_2\text{O} + \text{K}_2\text{O}}{\text{SiO}_2 + \text{Al}_2\text{O}_3 + \text{TiO}_2}$$

The B/A ratio indicates how much metal-containing ash will combine with low melting salts during the combustion process. Thus, the higher the B/A ratio, the more likely the bituminous coal is to slag. The ranges in Table 7 give a rough indication of the propensity of the coal to slag in pulverized coal-fired operations. This information has been transferred to all types of boiler arrangements as long as the lignitic or bituminous ashes are defined. Note: The following definitions apply for bituminous ashes:

Table 7. Slagging and fouling indexes.

| Slagging Type | Slagging Index (Rs) |
|---------------|---------------------|
| low | < 0.6 |
| medium | 0.6 - 2.0 |
| high | 2.0 - 2.6 |
| severe | > 2.6 |
| Fouling Type | Fouling Index (Rf) |
| low | < 0.2 |
| medium | 0.2 - 0.5 |
| high | 0.5 - 1.0 |
| severe | > 1.0 |

$$\text{Slagging Index (Rs)} = \text{B/A} \times \text{sulfur (dry)}$$

where sulfur is the weight percentage from analysis of the coal).

$$\text{Fouling Index (Rf)} = \text{B/A} \times \text{Na}_2\text{O}$$

where Na₂O is weight percentage from analysis of the coal ash.

Table 7 simplifies the Slagging and Fouling Indexes by defining categories of low, medium, high, and severe. The slagging correlation for lignitic ash is based on the ash fusion temperatures defining the slagging index as:

$$\text{Rs*} = \frac{(\text{Max HT}) + 4(\text{Min IT})}{5}$$

where:

Max HT = higher of the reducing or oxidizing hemispherical temperatures (°F)

Min IT = lower of the reducing or oxidizing initial deformation temperatures (°F).

Table 8 shows the relationship of R_s^* to slagging potential.

Table 8. Slagging factors and slagging potential.

| Factor | Potential |
|-----------------------|-----------|
| over 2450 | low |
| between 2450 and 2250 | medium |
| between 2250 and 2100 | high |
| under 2100 | severe |

Iron/Calcium Ratio

Laboratory studies show that as the iron/calcium ratio (Fe_2O_3/CaO) decreases, the softening temperature decreases. Table 9 shows values from ash analyses that illustrate this point.

Silica/Alumina Ratio

The silica/alumina ratio (SiO_2/Al_2O_3) can give additional information about the propensity of coal to slag. The ratios are not as well defined as the B/A ratio, but based on studies of ash fouling, coals with ash contents with high S/A ratios generally tend to have relatively low ash softening temperatures (Honea, July 1981).

Table 9. Effect of iron and calcium on softening temperature.

| Coal | Fe_2O_3 | CaO | Fe_2O_3/CaO | Softening Temp (°F) |
|------|-----------|-----|---------------|---------------------|
| 1 | 31.8 | 0.3 | 106.0 | 2360 |
| 2 | 24.8 | 2.0 | 12.4 | 2270 |
| 3 | 21.3 | 4.8 | 4.4 | 2130 |

Iron/Dolomite Ratio

The Iron/Dolomite Ratio is defined as: $Fe_2O_3/(CaO + MgO)$. Generally, as the iron/dolomite ratio increases, so does the softening temperature.

Ferric Percentage (FP)

$$\text{The Ferric Percentage (FP)} = [Fe_2O_3 / \text{Equiv } Fe_2O_3] \times 100$$

where:

$$\text{Equiv } Fe_2O_3 = Fe_2O_3 + 1.11 FeO + 1.43 Fe$$

The FP is important when the ash softening temperature is lower under reducing conditions than oxidizing conditions. Under strongly oxidizing conditions, the iron is mainly in the ferric state, Fe_2O_3 . Under more reducing conditions, the iron is mainly in the metallic state Fe. The completely oxidized state of iron, Fe_2O_3 , tends to raise the ash fusion temperatures. The lesser oxidized state of FeO tends to lower the ash fusion temperature. FP applies to the state of oxidation of the iron in coal-ash slag, and cannot be applied to laboratory prepared ash samples (*Coal Fouling and Slagging Parameters* 1974). Figure 8 shows this tendency under both oxidizing and reducing conditions for the initial deformation temperature.

Silica Percentage (SP)

$$\text{Silica Percentage (SP)} = [\text{SiO}_2 / (\text{SiO}_2 + \text{Equiv. Fe}_2\text{O}_3 + \text{CaO} + \text{MgO})] \times 100$$

Generally, as the SP increases, the slag viscosity also increases. The slag viscosity can be related to the ash hemispherical temperature. This relationship can be simplified to say that as the slag viscosity increases, the ash fusion temperature increases.

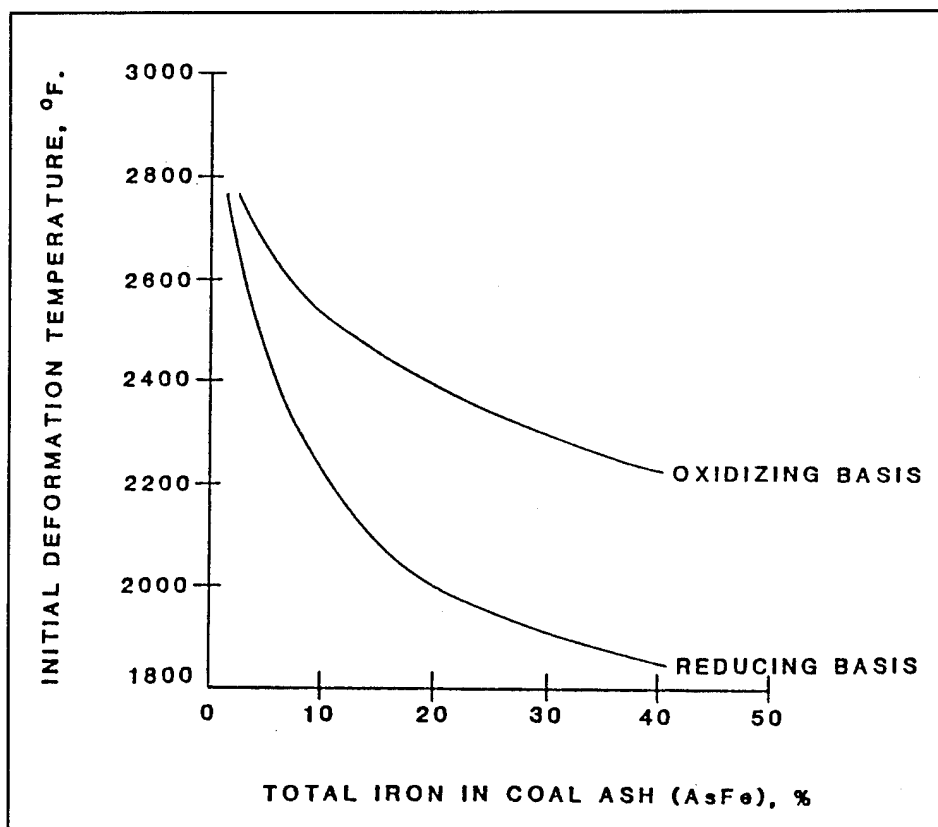

Figure 8. Change in initial deformation temperature under oxidizing and reducing conditions.

Total Alkalies ($\text{Na}_2\text{O} + \text{K}_2\text{O}$)

Total alkalies ($\text{Na}_2\text{O} + \text{K}_2\text{O}$) greatly increase the rate of deposits on screen tubes and reduce the ability to manage these deposits easily. The effect of the total alkalies is proportional to the quantity of alkali present in the coal. Coals with high sodium content (greater than 4 percent) tend to produce fouling and slagging problems.

For lignitic ash, the fouling potential is related to the Na_2O content as follows:

$\text{Na}_2\text{O} < 3$ = low to medium

$3 < \text{Na}_2\text{O} < 6$ = high

$6 < \text{Na}_2\text{O}$ = severe.

Slagging and Fouling Research

These indexes tend to put much of the blame for fouling and slagging on Na_2O . However, some research on the subject (discussed below) has cast doubt on the accuracy of these indexes. Complex reactions taking place inside the burning particle of coal can produce chemical reactions not accounted for in the previously mentioned indexes. Ash mineral composition is usually some combination of SiO_2 , Al_2O_3 , MgO , TiO , CaO , Na_2O , SO_3 , K_2O , P_2O_5 , and Fe_2O_3 . In lignitic ashes, the major components are silica, alumina, lime, and iron oxide or magnesia. The SiO_2 , Al_2O_3 , CaO , and MgO are refractory and have low vapor pressures at flame temperatures of less than 3632 °F. This means they will not normally volatilize and contribute to deposition. However, minerals inside the burning coal particle can experience reducing conditions even if the exterior of the particle is burning in an oxidizing atmosphere (Quann and Sarofim 1982). The reducing conditions inside the coal particle allow more volatile species such as SiO or Mg to be created. Most of the past research has been for pulverized coal burners where the material is micronized and burned in suspension. This information is not necessarily true for boilers using grates.

Other factors include the eutectics that take effect when the right combinations of elements or minerals come in contact (Manring and Bauer 1964). Once the coal has started to burn, the residence time of the ash in the boiler will determine the amount of ash vaporization (Honea, July 1981). A material that is vitreous will melt easier and at lower temperatures. When deposits of vitreous material are started, for whatever reason, they give a more active base for other material to deposit. In one instance, when repeated cleaning was required for one unit, it was removed from service and deposits on the convection surfaces and waterwalls were thoroughly

cleaned. No more problems were observed in the test period (about 1 year). Higher exit temperatures of the stack gas are correlated with higher deposits because most elements become active at elevated temperatures (Honea, July 1981).

Researchers have found that deposits (Figure 9) are made up of layers that can be manipulated by changing operating factors (Honea, July 1981). For example, reduced inner deposits can be achieved with higher probe temperatures (the probe simulates a boiler tube). But this also causes higher overall probe deposits.

The mineral that the ash oxide comes from will make a difference in the ash volatilization (Quann and Sarofim 1982). The high quantity of organically bound magnesium in subbituminous coal means that magnesium will be released at comparatively low temperatures.

Air saturated with water vapor carries more alkaline minerals than dry air. A high moisture coal with low Na_2O could produce the same effect as a coal that was dry but higher in sodium. Scanning electron micrographs show more dendrite growth in a

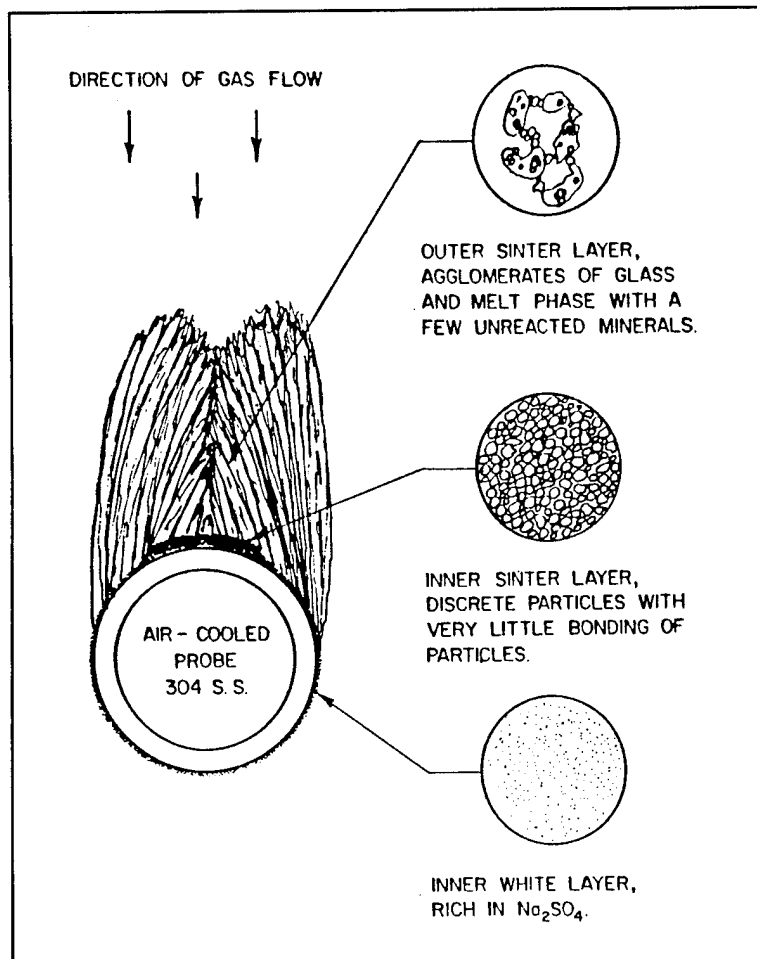

Figure 9. Ash deposition model.

high temperature moist atmosphere. Dendrite provides more surface area on which small particles can stick (Honea, Montgomery, and Jones, June 1981). Dendrites are pine-tree shaped crystals formed at the active outer surface of the probe. Another important factor in the devitrification of a phase from a homogeneous melt is the composition of the remaining liquid. The liquid phase will change depending on the amount of crystallization. This in turn will affect the viscosity and hence the rate of deposit growth (Honea, July 1981).

In tests run for the USEPA, researchers found that operating without the ash reinjection system reduced uncontrolled particulate loading by 70 to 80 percent. This implies that much of the material associated with fouling is not vapor phase transport material, but is fly ash in various stages of the sintering process. For any given unit, the heat release rate (Btu/h-SF) and particle loading are proportional. This does not mean that large boilers have high fouling, but that when the throughput of material and air is increased to nearly 100 percent of capacity, the fouling will also increase with any given coal.

The type of ash from unwashed coal appears to increase the particle loading (Langsjoen, Burlingame, and Gabrielson 1981). This is probably because the material consists of low density fine particulates and is easily carried out with stack gases. The likelihood of particles being entrained is a function of their size and density.

Grand Forks Energy Data Analysis

Because of the considerable volume of information from a single source (Grand Forks Energy Technology Center, U.S. Department of Energy [GFETC]) using a similar test furnace and procedure, USACERL researchers decided to evaluate this data to develop correlations between chemical components and slagging/fouling (Honea, July 1981). The GFETC Particulate Test Combustor (PTC) is designed for ash characterization. The test furnace layout is shown in Figure 10. Probes, internally cooled by compressed air, were placed in the 10-in. square duct to simulate superheater surfaces in a commercial boiler. The amount of material removed from the probes after a run is an indication of fouling potential of each coal.

Tables 10 and 11 list data on lignite and subbituminous coal, respectively. This information was entered in a spread sheet and sorted on the basis of probe deposit weight. Besides a zero data point at the top of the sort, zero was substituted for three "not available" data points, which explains why the probe information starts with zero and returns to zero for the last three points. All the information is still paired with the original line but is arranged by ascending probe weight. Each factor was graphed with

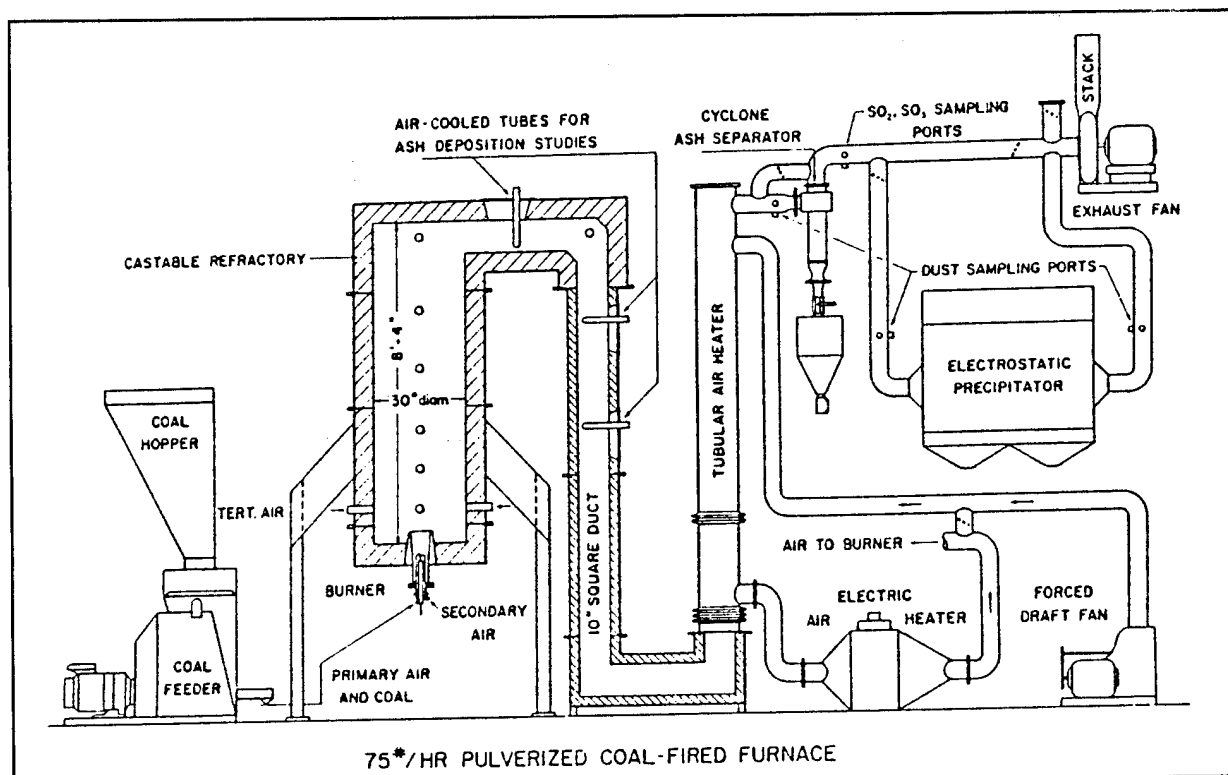

Figure 10. Layout of pilot plant test furnace and auxiliary equipment.

the probe data using two different scales, but maintaining the original relationship of the run which is labeled "category." This gives the probe a nearly straight curve and allows easy comparison of other factors.

Volatile organics had no apparent correlation with fouling (Figure 11); neither did any of the next 14 items investigated (Figures 12 through 25). The percent Na_2O in the ash does show a correlation (Figure 26), but only for very low deposits on the probe. Low probe deposit correlates with low sodium, but low sodium does not mean that low deposits will form. Na_2O shows in the first 9 entries of Table 11, a correlation when the probe weight is less than 53 grams. The next lowest fouling deposit of 73 grams had 8.4 percent Na_2O in the ash. As the deposit weights went up, the Na_2O percent did not necessarily go up. In fact, the highest probe deposit (1060 grams) was from coal that had 0.3 percent Na_2O in the ash and 22 percent ash in the coal. The probe deposit weight of 150 grams was the cutoff point for low fouling, 150 to 300 grams was medium, and over 300 grams was considered high fouling.

Graphs for K_2O and SO_3 (Figures 27 and 28, respectively) are added for completeness. Again, no correlation was apparent. Figure 29 illustrates no correlation between the B/A ratio, which is used to calculate slagging in bituminous coal, and the probe weight (Honea, Montgomery, and Jones, June 1981).

Table 10. Summary of lignites tested at GFETC.

| Sample | No. of tests | Coal analysis, dry basis | | | | Ash fusibility | | | | | | | | | | Coal ash analysis, percent | | | | | Ash deposit | | Relative fouling potential |
|--|--------------|---------------------------------------|--------------------|-----------------------|---------|-----------------------|--------|-------|-------|------------------|--------------------------------|--------------------------------|-----------------|-------------------------------|-----|----------------------------|-------------------|------------------|-----------------|------|-------------|--------|----------------------------|
| | | Moisture content of as-fired, percent | Volatiles, percent | Fixed carbon, percent | Percent | Heating value, Btu/lb | IT | ST | FT | SiO ₂ | Al ₂ O ₃ | Fe ₂ O ₃ | TI ₂ | P ₂ O ₅ | CaO | MgO | Na ₂ O | K ₂ O | SO ₂ | gms | bank = 1 | | |
| (NOONAN) BAUKOL-NOONAN MINE, BURKE COUNTY, NORTH DAKOTA | | | | | | | | | | | | | | | | | | | | | | | |
| BN-1 | 2 | 21 | 41.41 | 48.37 | 10.22 | 0.51 | 10,840 | 2,045 | 2,085 | 2,130 | 27.2 | 14.7 | 5.7 | 0.4 | 0.3 | 17.3 | 4.3 | 17.6 | 0.4 | 12.2 | 254 ± 176 | Medium | |
| BN-3 | 3 | 27 | 41.40 | 48.83 | 9.77 | .54 | 11,120 | 2,110 | 2,160 | 2,205 | 32.0 | 16.4 | 6.2 | .4 | .3 | 19.3 | 5.3 | 7.9 | .3 | 11.9 | 280 ± 113 | Medium | |
| BN-4 | 2 | 28 | 41.95 | 49.09 | 8.97 | .53 | 10,990 | 2,120 | 2,165 | 2,210 | 29.3 | 14.7 | 7.0 | .4 | .3 | 20.3 | 5.1 | 8.5 | .5 | 14.1 | 349 ± 50 | High | |
| (CENTER) BAUKOL-NOONAN MINE, OLIVER COUNTY, NORTH DAKOTA | | | | | | | | | | | | | | | | | | | | | | | |
| C-1 | 2 | 30 | 45.68 | 46.52 | 7.81 | 0.85 | 10,950 | 2,415 | 2,445 | 2,495 | 18.3 | 11.3 | 11.1 | 0.3 | 0.3 | 27.9 | 8.9 | 1.9 | 0.3 | 19.8 | 125 ± 15 | Low | |
| BEULAH MINE, MERCER COUNTY, NORTH DAKOTA | | | | | | | | | | | | | | | | | | | | | | | |
| B-1 | 4 | 25 | 43.24 | 44.71 | 12.05 | 1.82 | 10,360 | 2,235 | 2,285 | 2,340 | 17.9 | 12.8 | 15.8 | 0.4 | 0.1 | 20.9 | 5.3 | 1.1 | 0.2 | 25.5 | 123 ± 31 | Low | |
| B-2 | 4 | 28 | 39.63 | 48.57 | 11.80 | 1.31 | 10,490 | 2,085 | 2,130 | 2,180 | 19.9 | 9.8 | 9.3 | .4 | .3 | 19.0 | 6.8 | 9.4 | .4 | 24.8 | 377 ± 48 | High | |
| B-HL | 4 | 30 | 41.81 | 47.75 | 10.44 | 1.35 | 10,760 | 2,250 | 2,310 | 2,360 | 17.8 | 11.5 | 9.6 | .4 | .4 | 22.4 | 7.0 | 5.1 | .4 | 25.5 | 288 ± 25 | Medium | |
| B-STD | 8 | 30 | 41.55 | 47.71 | 10.73 | 1.03 | 10,550 | 2,220 | 2,270 | 2,315 | 20.2 | 11.3 | 9.8 | .4 | .5 | 21.8 | 8.0 | 6.3 | .3 | 21.4 | 313 ± 77 | High | |
| B-STD-II | 8 | 27.5 | | | | | 10,670 | 2,110 | 2,150 | 2,270 | 17.0 | 10.5 | 11.2 | .5 | .5 | 21.8 | 6.4 | 5.3 | .3 | 22.3 | 576 ± 160 | High | |
| PEERLESS MINE, BOWMAN COUNTY, NORTH DAKOTA | | | | | | | | | | | | | | | | | | | | | | | |
| G-1 | 3 | 32 | 42.70 | 44.92 | 12.38 | 1.47 | 10,570 | 2,240 | 2,280 | 2,325 | 24.6 | 13.4 | 7.0 | 0.4 | 0.3 | 21.7 | 8.4 | 3.2 | 0.3 | 20.7 | | Medium | |
| GLENHAROLD MINE, MERCER COUNTY, NORTH DAKOTA | | | | | | | | | | | | | | | | | | | | | | | |
| GH-1 | 2 | 31 | 44.23 | 47.34 | 8.34 | 0.94 | 11,000 | 2,220 | 2,260 | 2,295 | 16.1 | 8.8 | 12.2 | 0.4 | 0.1 | 22.3 | 5.5 | 9.6 | 0.5 | 24.5 | 289 ± 1 | Medium | |
| GH-2 | 2 | 33 | 44.31 | 46.84 | 8.85 | .68 | 10,820 | 2,210 | 2,240 | 2,270 | 21.6 | 9.7 | 8.0 | .3 | .1 | 25.3 | 6.1 | 9.9 | .5 | 18.2 | 318 ± 12 | High | |
| GH-3 | 2 | 30 | 43.69 | 44.99 | 11.33 | .86 | 10,530 | 2,115 | 2,145 | 2,175 | 35.1 | 12.1 | 7.2 | .5 | .1 | 17.0 | 4.5 | 6.9 | 1.0 | 15.6 | 402 ± 47 | High | |
| GH-4 | 1 | 32 | 43.51 | 47.66 | 8.83 | .90 | 11,090 | 2,140 | 2,190 | 2,280 | 17.2 | 8.0 | 11.0 | .3 | .2 | 24.0 | 6.0 | 11.5 | .5 | 21.3 | 403 | High | |
| GH-5 | 2 | 27 | 44.28 | 46.57 | 8.64 | .74 | 10,830 | 2,055 | 2,110 | 2,160 | 27.1 | 11.6 | 5.1 | .4 | .2 | 21.6 | 6.2 | 9.3 | .8 | 17.8 | 463 ± 31 | High | |
| INDIAN HEAD MINE, MERCER COUNTY, NORTH DAKOTA | | | | | | | | | | | | | | | | | | | | | | | |
| Z-2 | 2 | 27 | 41.10 | 47.19 | 11.71 | 1.37 | 10,970 | 2,095 | 2,140 | 2,185 | 19.8 | 11.6 | 9.0 | 0.3 | 0.3 | 22.6 | 6.2 | 7.3 | 0.3 | 21.9 | 539 ± 92 | High | |
| VELVA MINE, WARD COUNTY, NORTH DAKOTA | | | | | | | | | | | | | | | | | | | | | | | |
| V-1 | 4 | 32 | 41.72 | 51.27 | 7.01 | 0.30 | 10,780 | 2,540 | 2,580 | 2,615 | 13.4 | 7.9 | 6.7 | 0.2 | 0.2 | 39.2 | 10.4 | 7.8 | 0.4 | 13.8 | 113 ± 51 | Low | |
| V-2 | 3 | 29 | 38.37 | 50.22 | 11.41 | .29 | 10,100 | 2,340 | 2,385 | 2,425 | 33.1 | 14.3 | 4.0 | .5 | .1 | 32.2 | 6.2 | 2.8 | .2 | 6.5 | 259 ± 83 | Medium | |
| V-3 | 2 | 31 | 40.96 | 50.18 | 8.85 | .53 | 10,580 | 2,455 | 2,490 | 2,525 | 22.3 | 10.1 | 6.6 | .4 | .4 | 39.2 | 9.5 | 1.4 | .3 | 9.8 | 140 ± 30 | Low | |
| V-4 | 2 | 34 | 42.18 | 49.51 | 8.32 | .36 | 10,670 | 2,425 | 2,470 | 2,515 | 24.4 | 11.1 | 6.3 | .4 | .2 | 32.9 | 8.0 | 4.0 | .5 | 12.2 | 153 ± 2 | Low | |
| SAVAGE MINE, RICHLAND COUNTY, MONTANA | | | | | | | | | | | | | | | | | | | | | | | |
| S-1 | 3 | 34 | 40.98 | 47.26 | 11.77 | 1.04 | 10,230 | 2,250 | 2,300 | 2,350 | 21.3 | 13.0 | 10.0 | 0.3 | 0.3 | 22.7 | 9.3 | 0.4 | 0.3 | 21.9 | 45 ± 9 | Low | |
| S-2 | 3 | 30 | 42.18 | 44.03 | 13.78 | .80 | 10,230 | 2,050 | 2,100 | 2,150 | 35.7 | 20.3 | 5.3 | .6 | .6 | 16.4 | 7.0 | .4 | .9 | 12.8 | 105 ± 38 | Low | |

Table 11. Data on subbituminous and bituminous coals.

| State | Mine or Designation | Sample Identification | No. of Tests | Moisture-Free Coal | | Moisture-Free Analysis, Pct | | Heat value, Btu/lb | Ash Fusion Temperature, °F | | Ash Analysis, Percent | | | | | | | Probe Bank #1 Deposit wt., gr. | Relative Fouling Potential | | | | | | |
|------------------------------|---------------------|-----------------------|--------------|--------------------|----------|-----------------------------|----------|--------------------|----------------------------|-------|-----------------------|-----------|---------------------|-----------|-------|------------------|--------------------------------|--------------------------------|----------------------------|--------------------------------|-----------------|-------------------------------|------|------|-------------------|
| | | | | Rate, lbs/hr | As-fired | Moisture, percent | Volatile | | Fixed Carbon | Ash | Sulfur | Dry Basis | Initial Deformation | Softening | Final | SiO ₂ | Al ₂ O ₃ | | | Fe ₂ O ₃ | TI ₂ | P ₂ O ₅ | CaO | MgO | Na ₂ O |
| WESTERN SUBBITUMINOUS COALS: | | | | | | | | | | | | | | | | | | | | | | | | | |
| Alaska | Placer Amxex | Alas-1 | 1 | 73.8 | 17 | 42.3 | 35.6 | 22.1 | 0.25 | 91.50 | 2320 | 2370 | 2420 | 55.0 | 27.3 | 4.8 | 0.5 | 0.8 | 4.9 | 3.4 | 0.3 | 1.9 | 1.1 | 1060 | High |
| Montana | Ayshire Anderson | Ayr A | 2 | 46.2 | 26 | 40.0 | 54.0 | 6.0 | 0.38 | 11690 | 2090 | 2130 | 2170 | 24.8 | 16.4 | 4.5 | 0.8 | 0.4 | 20.3 | 5.4 | 13.5 | 0.3 | 13.6 | 163 | Medium |
| | Ayshire Knoblock | Ayr K | 1 | 47.3 | 22 | 40.3 | 52.7 | 7.0 | 0.84 | 12060 | 2060 | 2110 | 2170 | 32.3 | 19.6 | 4.1 | 0.5 | 0.9 | 15.0 | 3.8 | 10.6 | 0.4 | 12.8 | 181 | Medium |
| | Colstrip Rosebud | CS-1 | 2 | 44.4 | 21 | 39.9 | 50.4 | 9.7 | 0.84 | 11620 | 2190 | 2220 | 2250 | 35.4 | 19.0 | 5.6 | 0.8 | 0.3 | 17.8 | 4.4 | 0.3 | 0.1 | 16.3 | 44 | Low |
| | Colstrip | CS-2 | 2 | 52.0 | 17 | 39.6 | 50.5 | 10.0 | 0.82 | 11840 | 2130 | 2170 | 2210 | 45.8 | 19.3 | 5.8 | 0.6 | 0.2 | 12.7 | 3.9 | 0.4 | 0.2 | 11.1 | 141 | Low |
| | Colstrip | CS-3 | 1 | - | 17 | 39.0 | 50.0 | 10.7 | 0.90 | 11440 | 2040 | 2080 | 2120 | 36.6 | 14.4 | 22.8 | 0.6 | 0.2 | 8.2 | 2.5 | 0.6 | 1.2 | 10.9 | 10 | Low |
| | Colstrip McKay | CS-MK | 2 | 43.3 | 24 | 37.5 | 50.3 | 12.1 | 1.55 | 10980 | 2150 | 2200 | 2250 | 38.9 | 17.5 | 5.9 | 0.9 | 0.3 | 17.0 | 5.2 | 0.5 | 0.2 | 12.8 | 52 | Low |
| | Decker 1 | D-1 | 1 | 43.9 | 16 | 41.5 | 54.0 | 4.5 | 0.26 | 12000 | 2000 | 2040 | 2080 | 25.4 | 15.6 | 6.1 | 0.8 | 0.3 | 19.4 | 4.3 | 8.4 | 0.4 | 19.3 | 73 | Low |
| | Decker 2 | D-2 | 1 | 45.0 | 16 | 40.7 | 51.9 | 7.4 | 1.67 | 11930 | 2010 | 2050 | 2090 | 26.3 | 19.0 | 18.9 | 1.0 | 1.3 | 11.9 | 2.2 | 5.8 | 0.5 | 13.1 | 118 | Low |
| | Decker 3 | D-3 | 1 | 42.6 | 18 | 41.3 | 53.3 | 5.5 | 0.84 | 12400 | 2050 | 2100 | 2150 | 18.0 | 17.7 | 9.4 | 0.6 | 2.2 | 16.0 | 2.8 | 8.2 | 0.3 | 24.8 | 134 | Low |
| | Decker Standard | D-STD | 6 | 46.8 | 16 | 41.5 | 53.2 | 5.4 | 0.43 | 12200 | 2080 | 2130 | 2240 | 30.8 | 14.3 | 7.9 | 0.5 | 0.3 | 15.5 | 3.4 | 6.1 | 0.4 | 20.8 | 139 | Low |
| | Starry Creek | SC-2 | 1 | 64.0 | 21 | 38.9 | 50.9 | 10.2 | 0.91 | 11650 | 2090 | 2130 | 2170 | 31.2 | 17.6 | 5.2 | 0.8 | 0.5 | 21.0 | 2.4 | 4.3 | 0.5 | 14.7 | 205 | Medium |
| | Shell (Cores) | Shell | 1 | 46.0 | 19 | 42.7 | 51.5 | 5.8 | 0.36 | 12070 | 2080 | 2120 | 2160 | 31.3 | 15.6 | 5.7 | 0.2 | 0.4 | 19.0 | 4.7 | 7.2 | 0.7 | 15.2 | 165 | Medium |
| New Mexico | Navajo #1 | N-1 | 1 | 57.2 | 10 | 33.9 | 40.4 | 25.7 | 0.74 | 9950 | 2570 | 2620 | 2680 | 58.5 | 26.6 | 4.2 | 0.6 | 0.2 | 3.6 | 1.1 | 1.4 | 0.5 | 3.3 | 111 | * |
| | Navajo #2 | N-2 | 1 | 52.7 | 8 | 35.2 | 46.1 | 18.7 | 1.30 | 11070 | 2500 | 2550 | 2600 | 53.7 | 26.3 | 8.1 | 0.6 | 0.8 | 4.3 | 0.6 | 1.7 | 0.8 | 3.1 | 111 | * |
| Utah | Kapiowitz | KALP | 1 | 48.4 | 7 | 42.8 | 47.6 | 9.7 | 0.63 | 12280 | 2190 | 2260 | 2560 | 58.1 | 17.2 | 4.9 | 0.8 | 0.0 | 7.9 | 1.7 | 0.5 | 0.5 | 8.4 | 33 | Low |
| | Centralia #1 | Can 1 | 3 | 54.6 | 17 | 41.7 | 45.75 | 12.6 | 0.57 | 11240 | 2250 | 2300 | 2350 | 46.2 | 25.7 | 6.1 | 3.7 | 1.3 | 9.6 | 1.5 | 0.5 | 0.2 | 5.2 | NA | ** |
| Washington | Centralia #2 | Can 2 | 1 | 60.3 | 18 | 40.8 | 44.7 | 14.5 | 0.61 | 10880 | 2580 | 2630 | 2730 | 46.2 | 24.3 | 5.3 | 2.7 | 1.6 | 9.8 | 2.2 | 0.9 | 0.3 | 6.7 | NA | ** |
| Wyoming | Belle Ayr | BA | 1 | 54.2 | 23 | 45.5 | 47.7 | 6.8 | 0.65 | 11510 | 2080 | 2120 | 2160 | 26.2 | 15.4 | 6.4 | 1.3 | 1.1 | 25.4 | 4.1 | 1.7 | 0.2 | 15.5 | 74 | Low |
| | Big Horn #1 | BH-1 | 1 | 46.9 | 17 | 41.9 | 52.1 | 6.0 | 0.63 | 12040 | 2070 | 2110 | 2150 | 26.3 | 19.0 | 7.7 | 0.5 | 1.4 | 16.7 | 5.8 | 4.8 | 0.5 | 17.3 | 114 | Low |
| | Big Horn #2 | BH-2 | 1 | 46.5 | 17 | 40.9 | 53.3 | 5.8 | 0.51 | 12110 | 2140 | 2190 | 2240 | 27.7 | 16.1 | 10.3 | 0.5 | 0.4 | 16.7 | 5.7 | 4.8 | 0.5 | 17.3 | 118 | Low |
| | Big Horn #3 | BH-3 | 1 | 44.5 | 19 | 41.5 | 54.0 | 4.4 | 0.53 | 12370 | 2150 | 2200 | 2250 | 23.1 | 13.5 | 8.5 | 0.8 | 0.9 | 20.2 | 6.1 | 4.8 | 0.4 | 21.7 | 81 | Low |
| | Glenrock | GR-1 | 2 | 49.2 | 22 | 45.4 | 44.6 | 10.0 | 0.82 | 11110 | 2120 | 2155 | 2190 | 30.5 | 15.7 | 6.6 | 0.6 | 0.4 | 25.5 | 3.7 | 0.3 | 0.5 | 16.4 | 21 | Low |
| | Jim Bridger | JB | 1 | 65.5 | 14 | 36.7 | 49.5 | 13.8 | 0.70 | 11320 | 2250 | 2300 | 2350 | 38.3 | 17.0 | 4.5 | 1.1 | 0.2 | 6.6 | 2.0 | 0.8 | 0.6 | 6.2 | 154 | Medium |
| | Kemmerer #1 | K-1 | 1 | 53.1 | 19 | 42.1 | 50.9 | 7.0 | 1.02 | 11520 | 2070 | 2120 | 2250 | 53.3 | 14.6 | 16.0 | 0.3 | 0.4 | 5.5 | 1.2 | 0.4 | 0.4 | 7.9 | 11 | Low |
| | Kemmerer #2 | K-2 | 1 | 49.4 | 18 | 42.6 | 53.0 | 4.4 | 0.96 | 12547 | 2090 | 2140 | 2260 | 47.0 | 8.4 | 7.7 | 0.1 | 0.1 | 11.1 | 5.8 | 0.2 | 0.5 | 19.3 | 13 | Low |
| | Reynolds Mining | RM | 1 | 61.5 | 21 | 38.0 | 42.9 | 19.1 | 0.74 | 9870 | 2080 | 2130 | 2180 | 49.0 | 22.7 | 8.4 | 0.8 | 0.3 | 6.2 | 3.0 | 0.9 | 1.8 | 6.9 | 107 | Low |
| | Rosebud | RWY | 1 | 49.7 | 10 | 42.3 | 53.9 | 3.8 | 0.91 | 12810 | 1980 | 2030 | 2080 | 21.2 | 14.3 | 21.7 | 0.8 | 0.3 | 14.1 | 6.0 | 0.4 | 0.3 | 18.0 | 5 | Low |
| | Seminole #1A | Sam A | 1 | 56.1 | 12 | 36.4 | 48.0 | 15.6 | 0.50 | 10570 | 2140 | 2190 | 2250 | 53.2 | 16.6 | 4.3 | 0.4 | 0.4 | 13.9 | 3.2 | 0.4 | 1.4 | 6.1 | 131 | Low |
| | Seminole #1B | Sam B | 1 | 55.0 | 8 | 44.5 | 39.8 | 0.74 | 0.74 | 11220 | 2100 | 2140 | 2180 | 47.6 | 21.0 | 6.8 | 1.0 | 0.4 | 10.1 | 2.7 | 0.4 | 1.3 | 6.0 | 11 | Low |
| BITUMINOUS COALS: | | | | | | | | | | | | | | | | | | | | | | | | | |
| Illinois | Mine #10 | Ill-1 | 2 | 46.3 | 12 | 39.7 | 43.7 | 16.5 | 4.99 | 11536 | 1905 | 1945 | 1985 | 43.7 | 17.0 | 21.3 | 0.5 | 0.3 | 7.0 | 1.0 | 1.5 | 1.4 | 6.1 | 152 | Medium |
| | Riverking | Ill-2 | 2 | 51.2 | 8 | 37.1 | 42.6 | 20.4 | 5.32 | 11125 | 1965 | 2030 | 2100 | 47.6 | 17.6 | 19.2 | 0.9 | 0.4 | 6.1 | 2.2 | 0.5 | 1.6 | 3.8 | NA | Low |
| | Hillsboro | Ill-3 | 1 | 52.5 | 10 | 40.3 | 47.4 | 12.2 | 4.69 | 12180 | 1960 | 2010 | 2060 | 37.7 | 16.7 | 28.0 | 0.5 | 0.1 | 8.4 | 0.6 | 1.6 | 1.0 | 5.4 | 395 | High |
| Utah | Sunnyside | SS-1 | 2 | 41.4 | 4 | 39.9 | 54.1 | 6.1 | 0.74 | 13862 | 2445 | 2500 | 2555 | 59.2 | 24.6 | 4.5 | 1.1 | 1.7 | 4.6 | 0.4 | 1.1 | 0.3 | 2.5 | 53 | Low |
| | NA | U-1 | 2 | 41.4 | 3 | 41.1 | 50.7 | 8.3 | 0.99 | 13180 | 2030 | 2080 | 2180 | 42.4 | 16.2 | 9.3 | 0.8 | 0.3 | 12.5 | 3.4 | 1.4 | 0.0 | 13.8 | 120 | Low |
| West Virginia | Atkwright | ARK-1 | 1 | 37.0 | 1 | 38.2 | 38.2 | 6.9 | 2.10 | 14020 | 2140 | 2190 | 2270 | 44.8 | 29.4 | 15.4 | 0.5 | 0.3 | 4.2 | 1.0 | 0.8 | 0.5 | 3.7 | NA | Low |

NA - Not available. * In the Navajo tests, ash did not adhere strongly to the tubes, but the duct had to be cleaned of loose ash to permit test continuation in usual manner. **During Centralia tests, ash built on refractory duct walls and eventually bridged across tubes. Ash did not appear to bond much to the metal tubes.

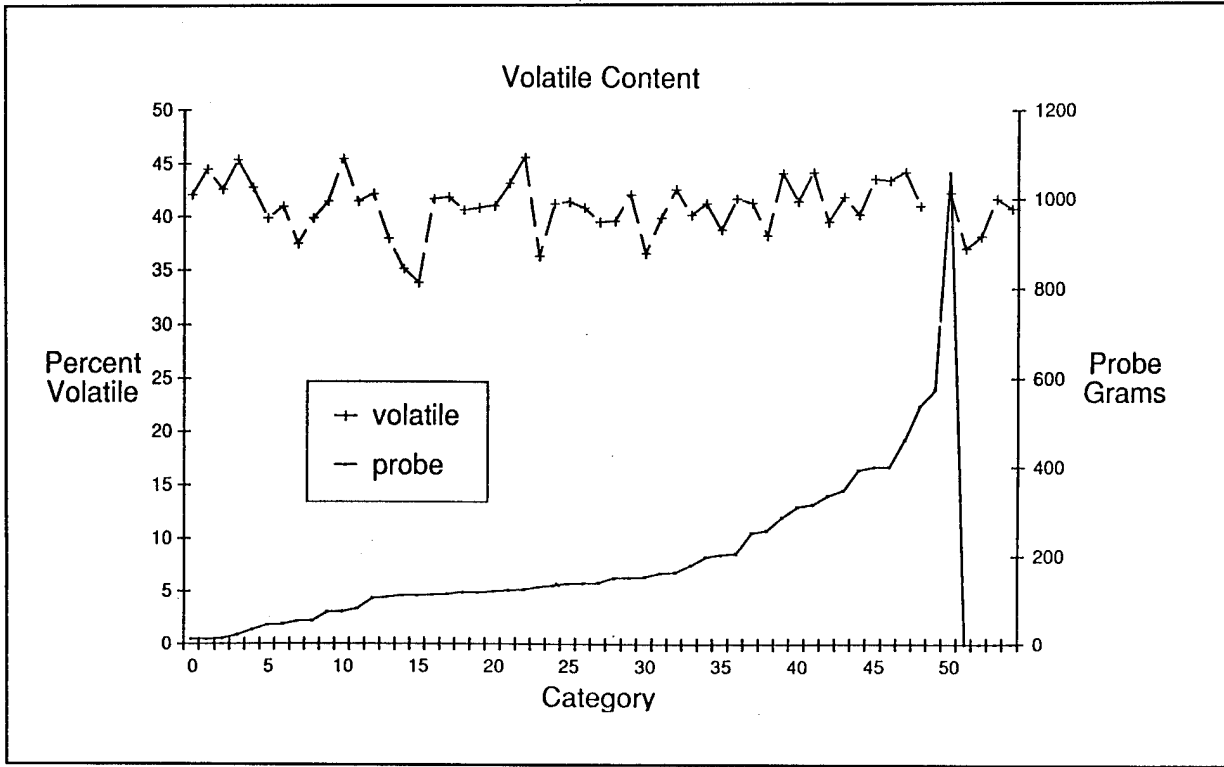

Figure 11. Correlation between fouling and volatile organics.

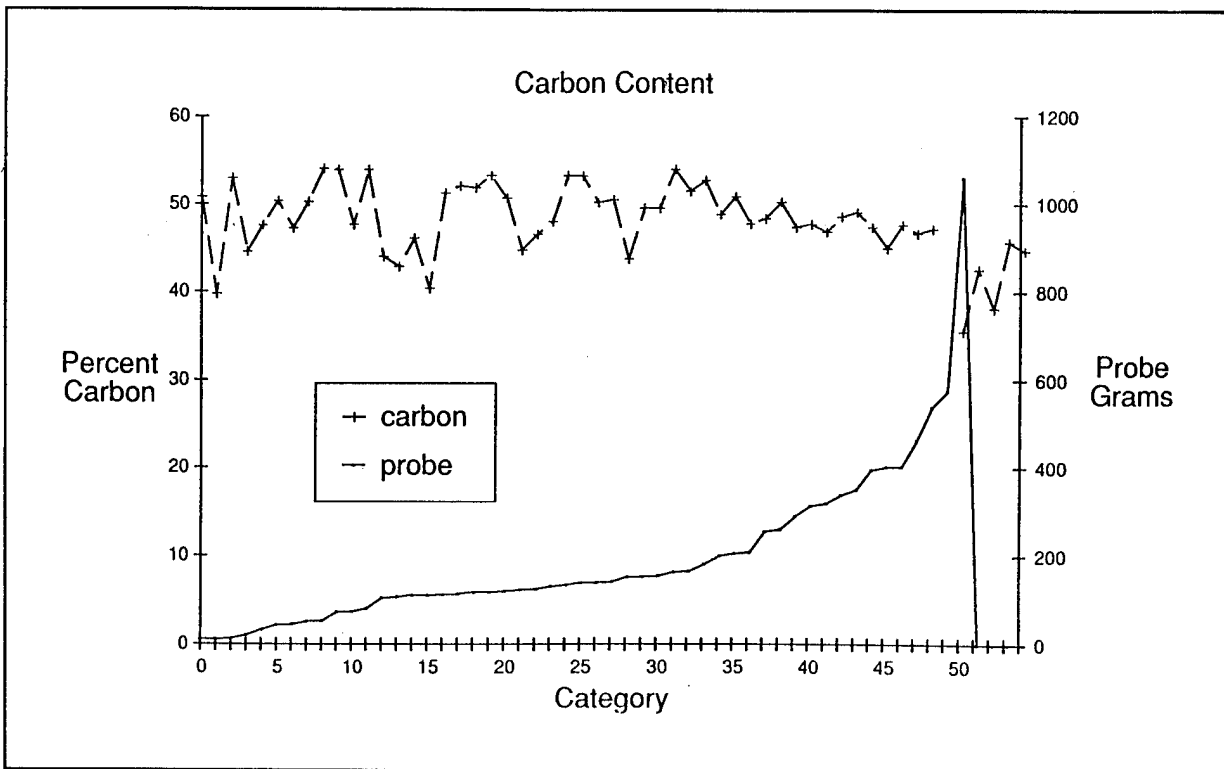

Figure 12. Correlation between fouling and carbon content.

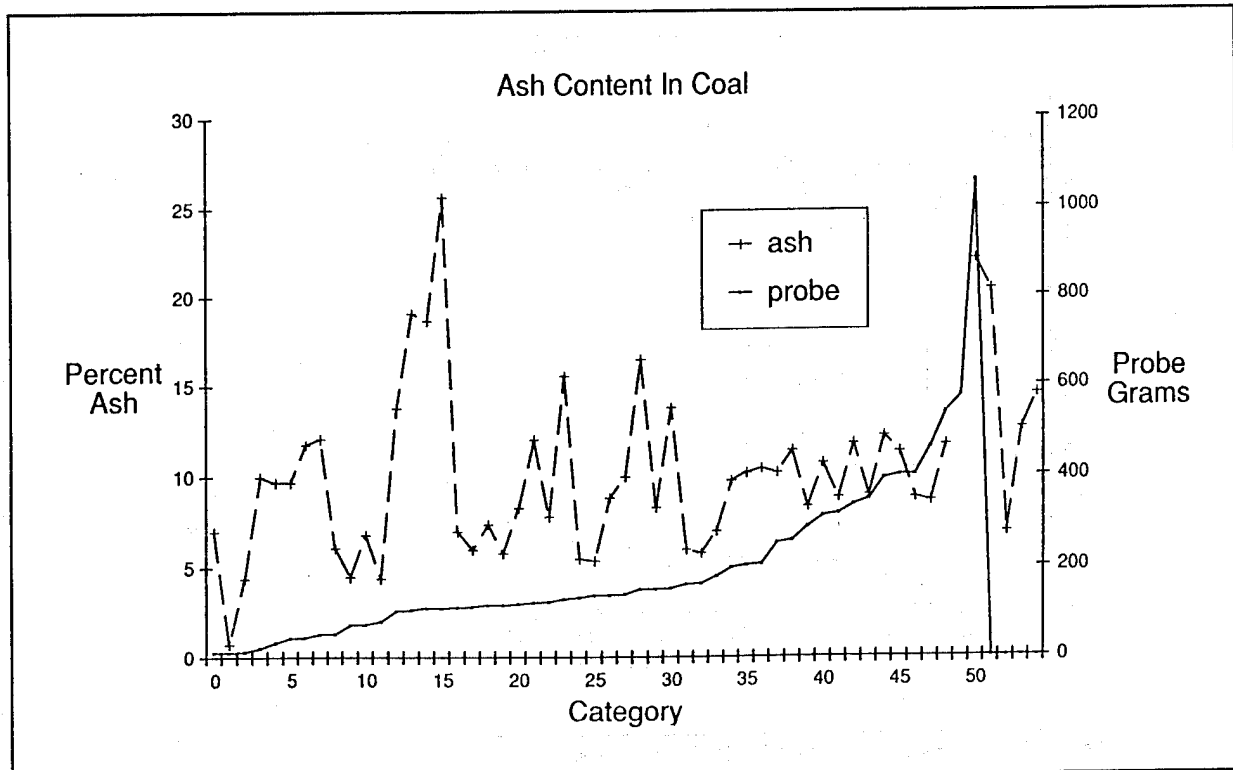

Figure 13. Correlation between fouling and ash content.

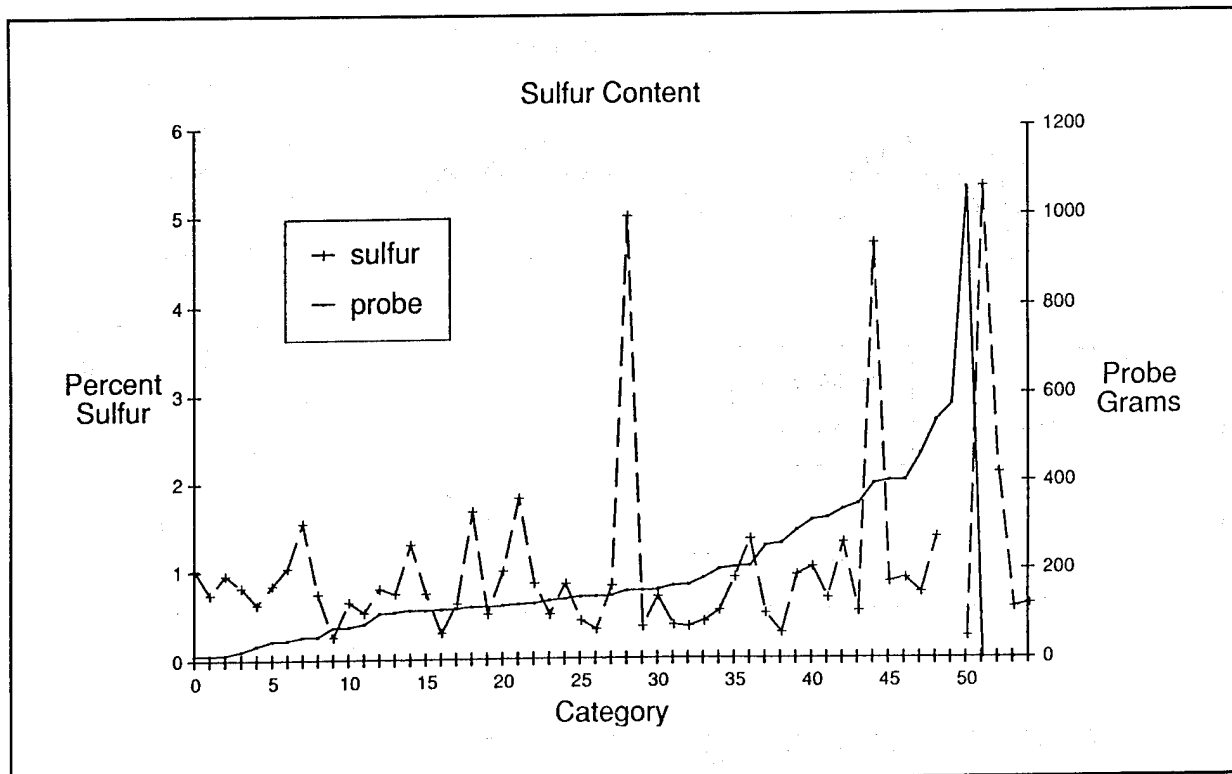

Figure 14. Correlation between fouling and sulphur content.

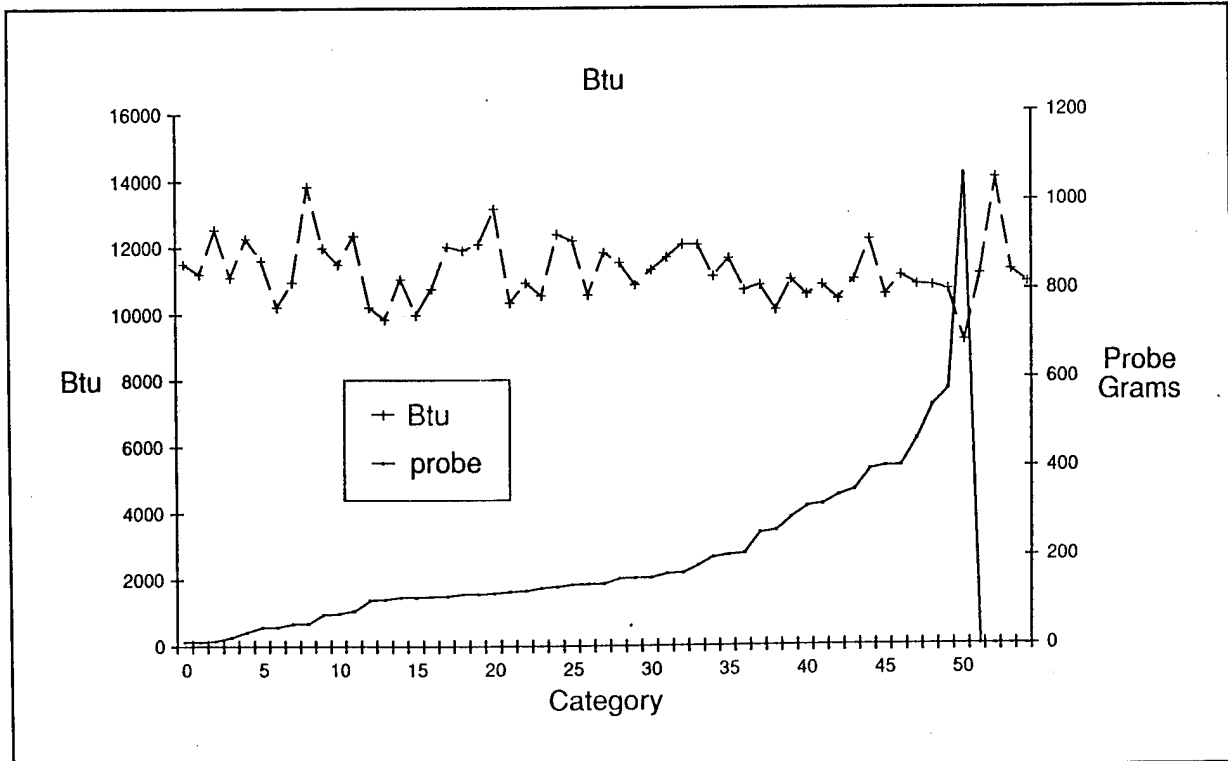

Figure 15. Correlation between fouling and Btu content.

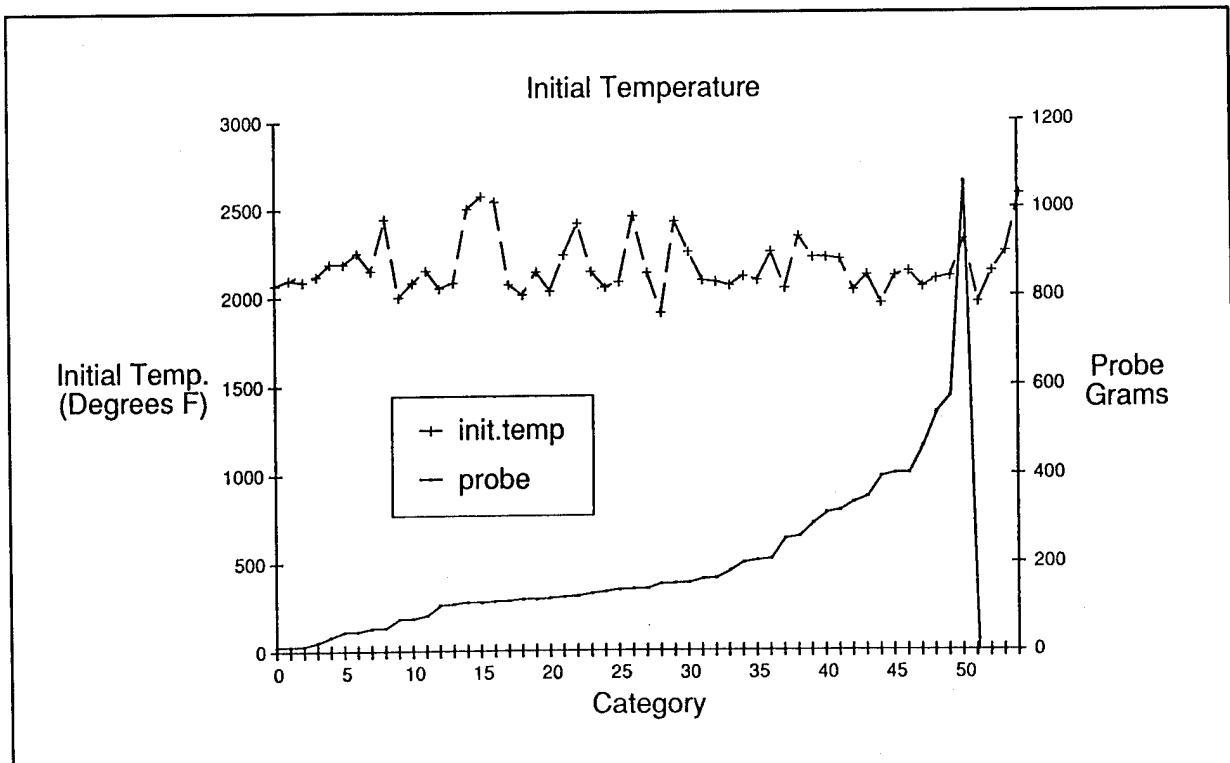

Figure 16. Correlation between fouling and initial temperature.

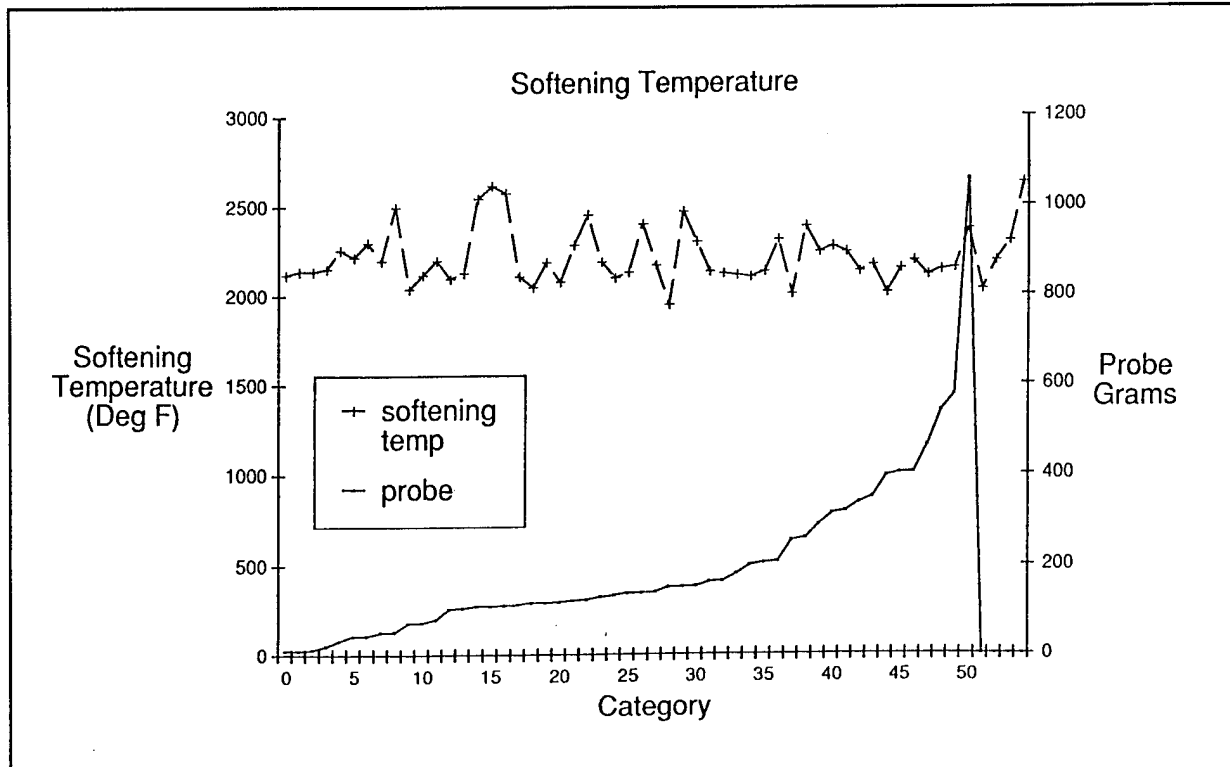

Figure 17. Correlation between fouling and softening temperature.

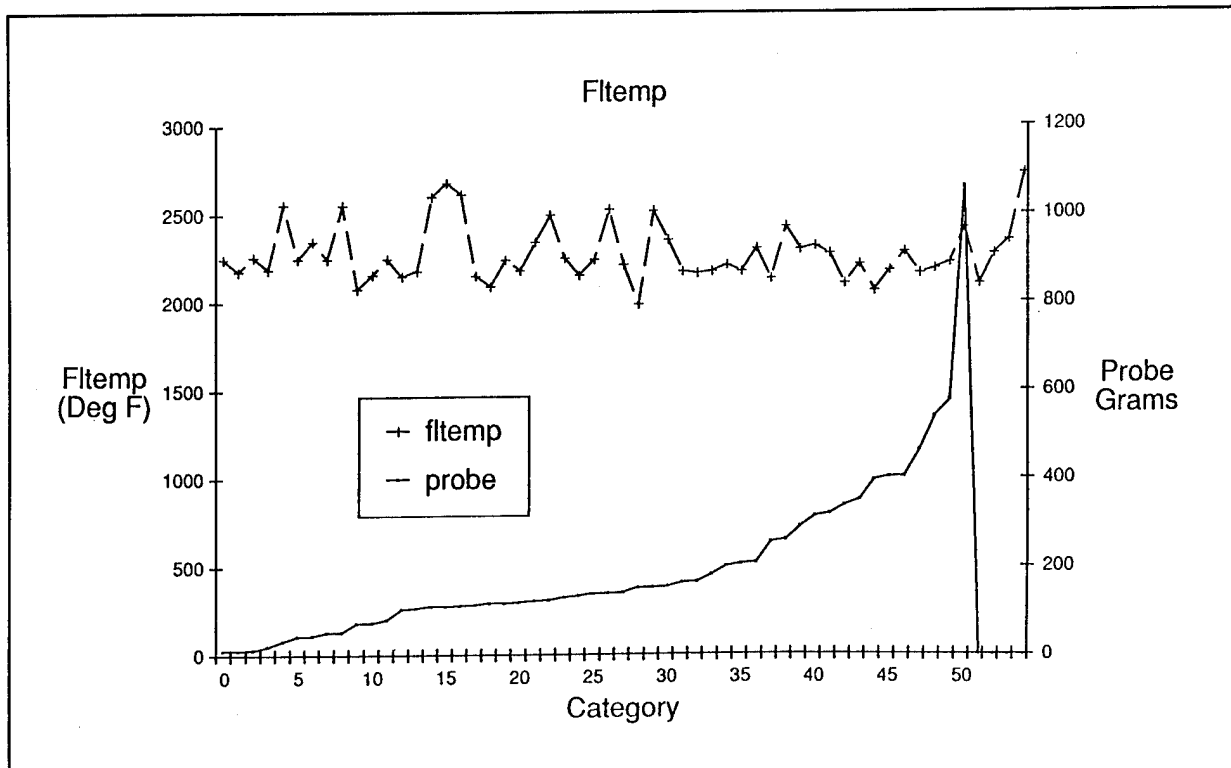

Figure 18. Correlation between fouling and flue temperature.

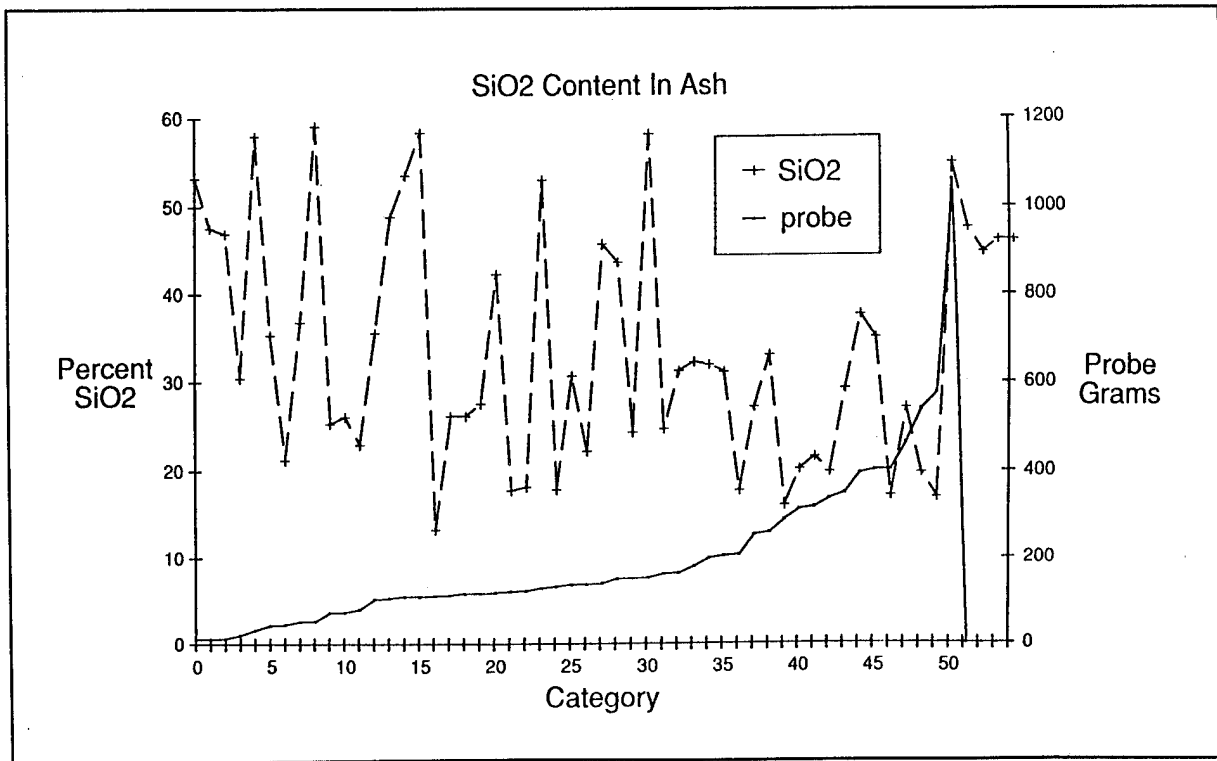

Figure 19. Correlation between fouling and SiO₂.

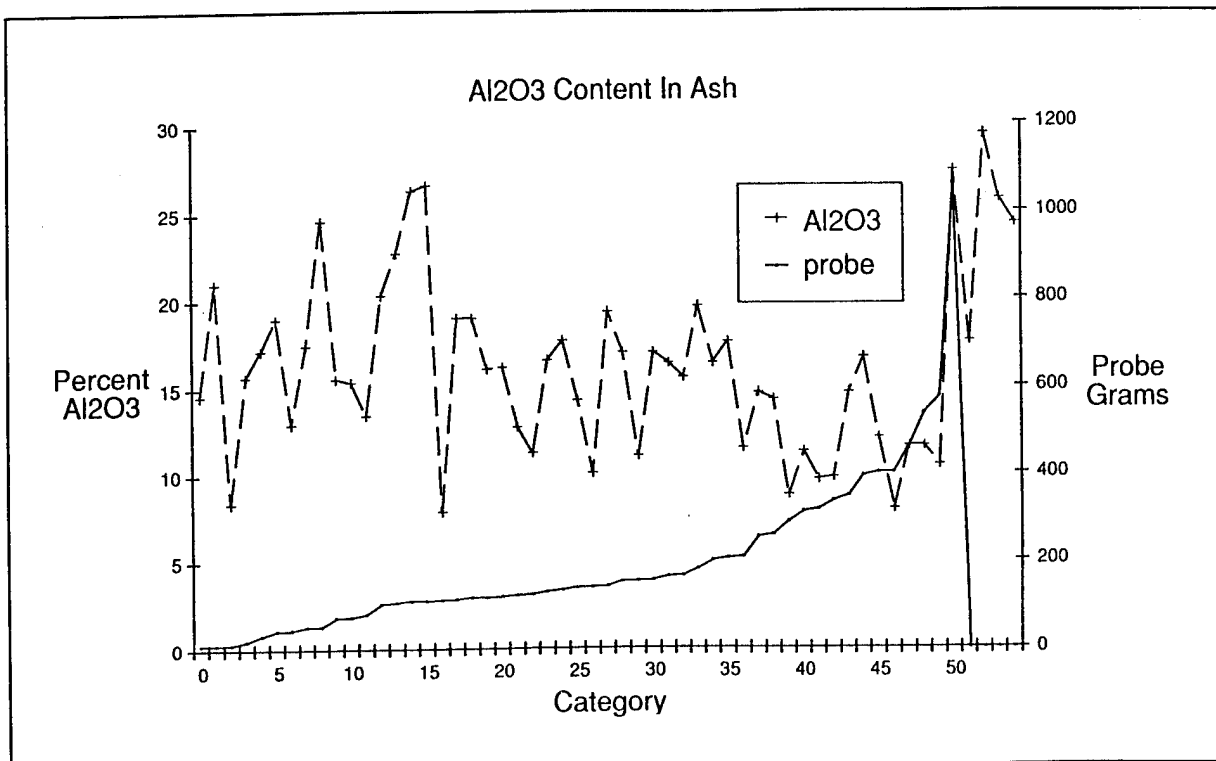

Figure 20. Correlation between fouling and Al₂O₃.

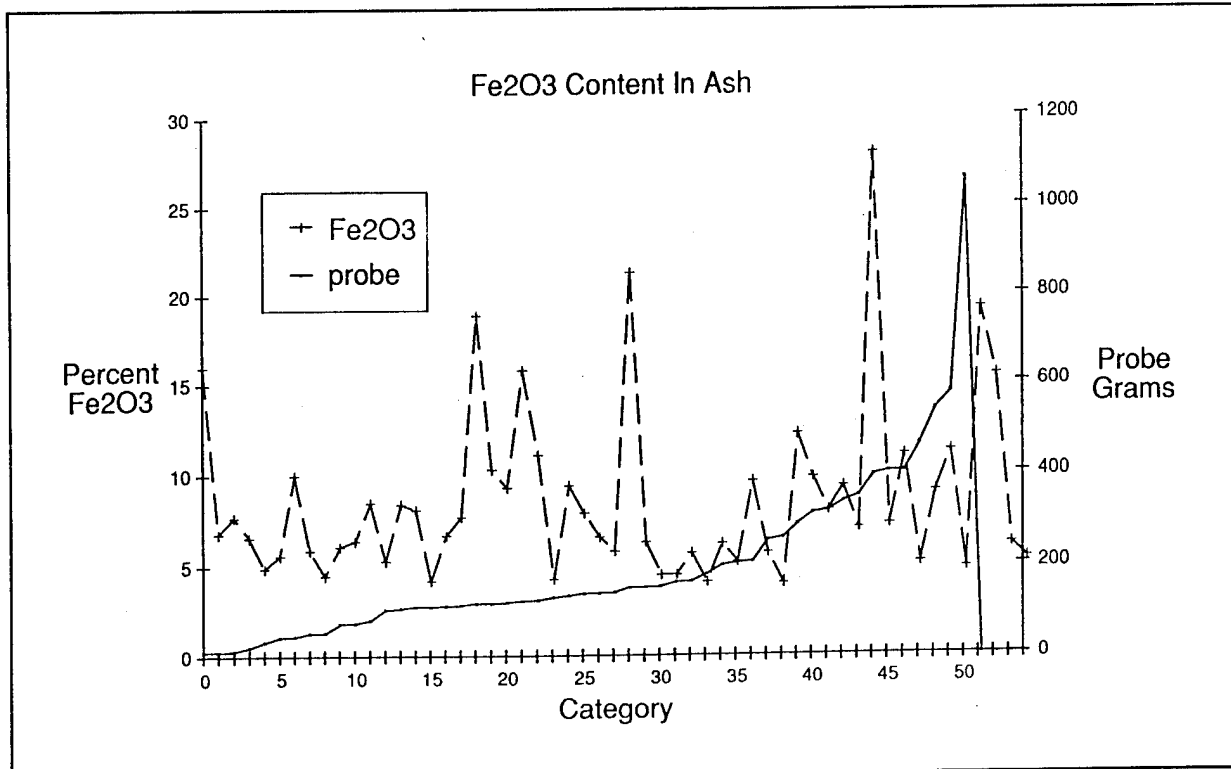

Figure 21. Correlation between fouling and Fe₂O₃.

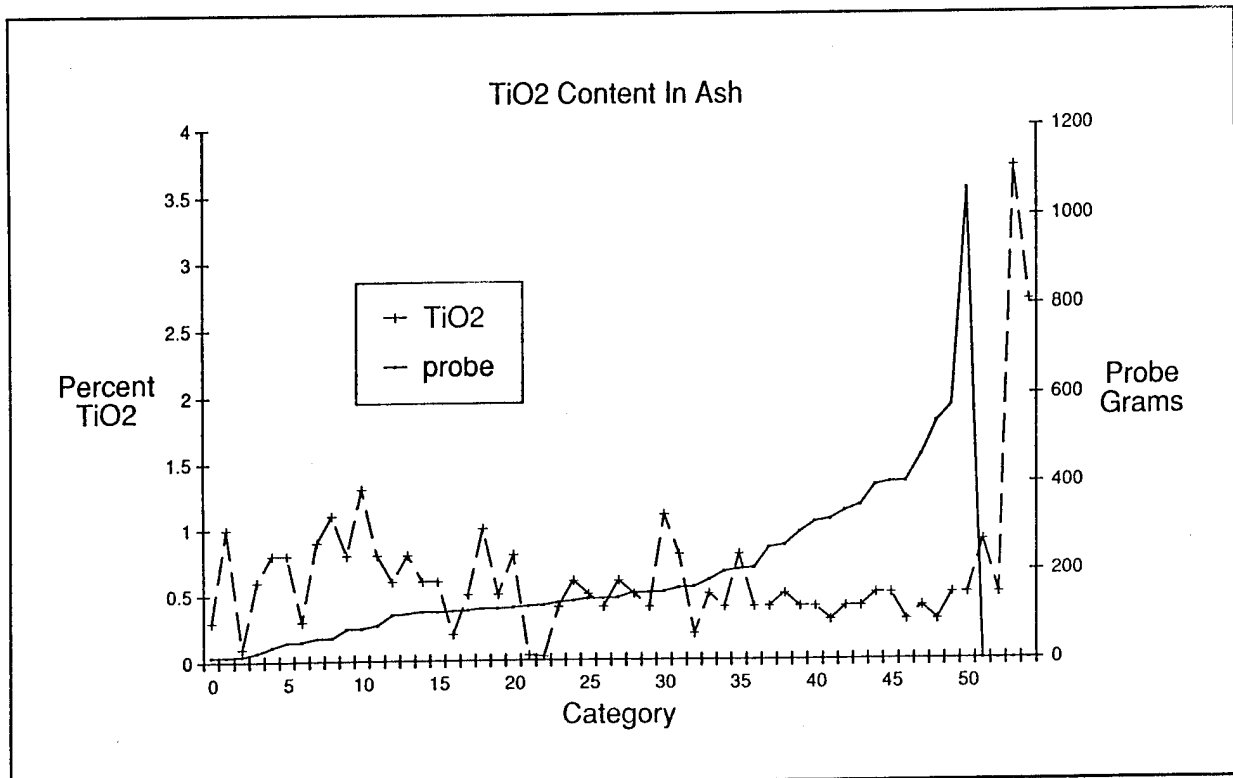

Figure 22. Correlation between fouling and TiO₂ content in ash.

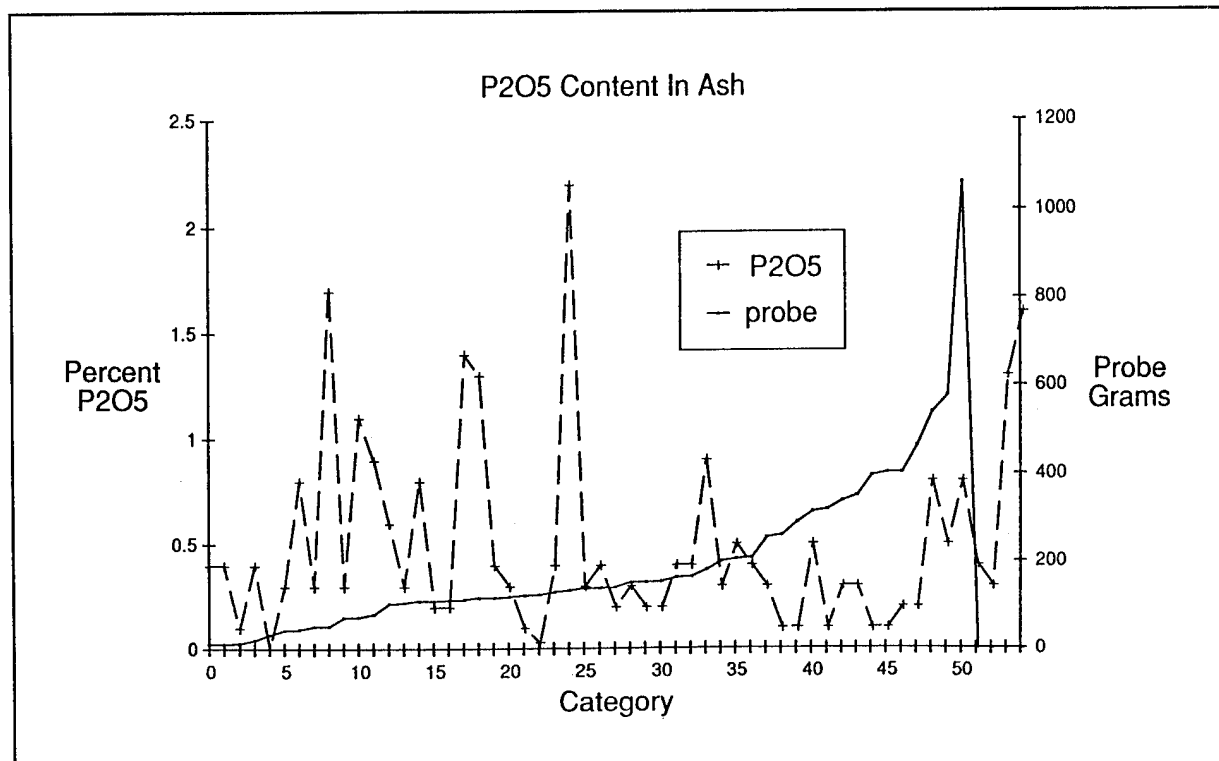

Figure 23. Correlation between fouling and P₂O₅ content in ash.

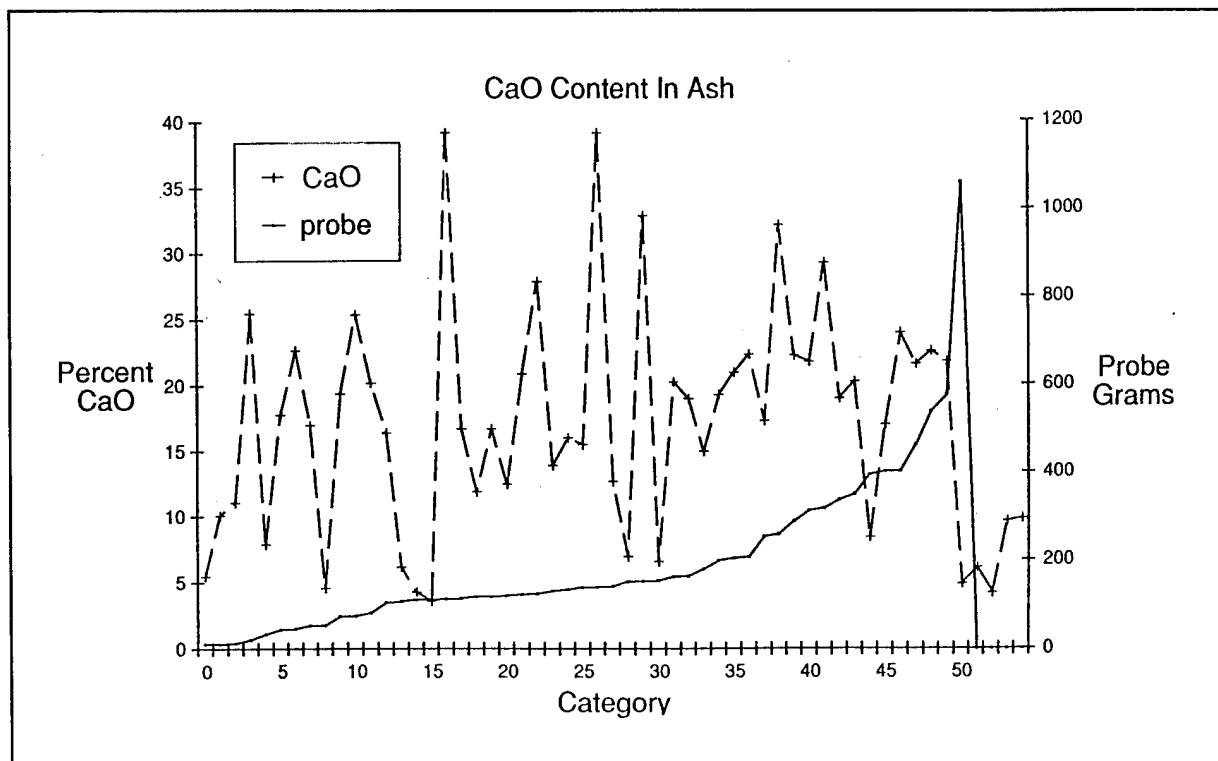

Figure 24. Correlation between fouling and CaO content in ash.

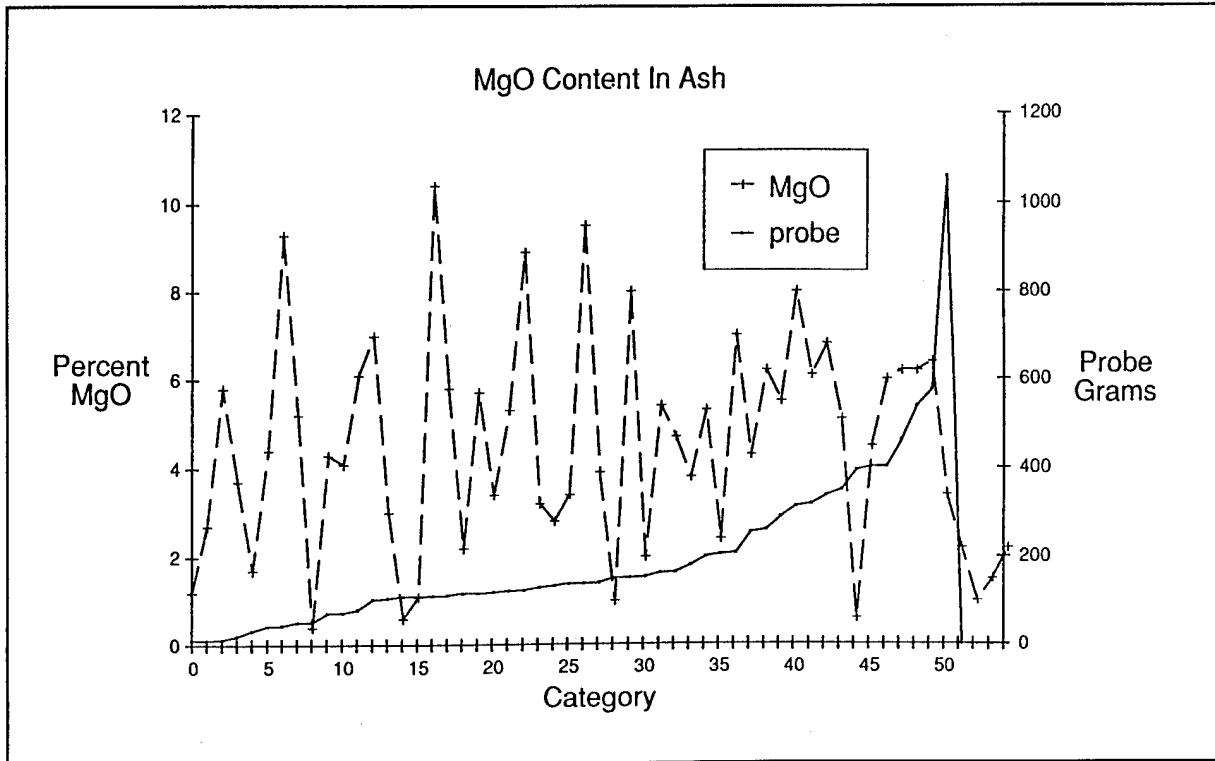

Figure 25. Correlation between fouling and MgO content in ash.

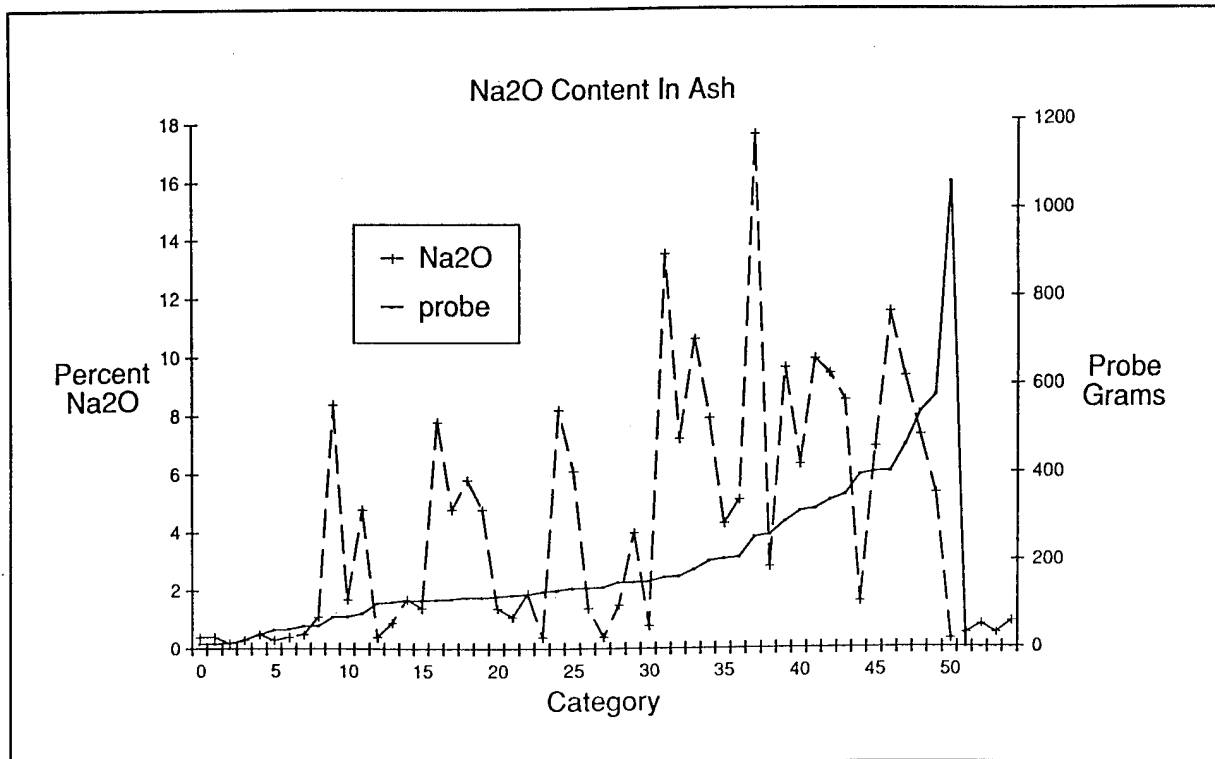

Figure 26. Correlation between fouling and Na₂O content in ash.

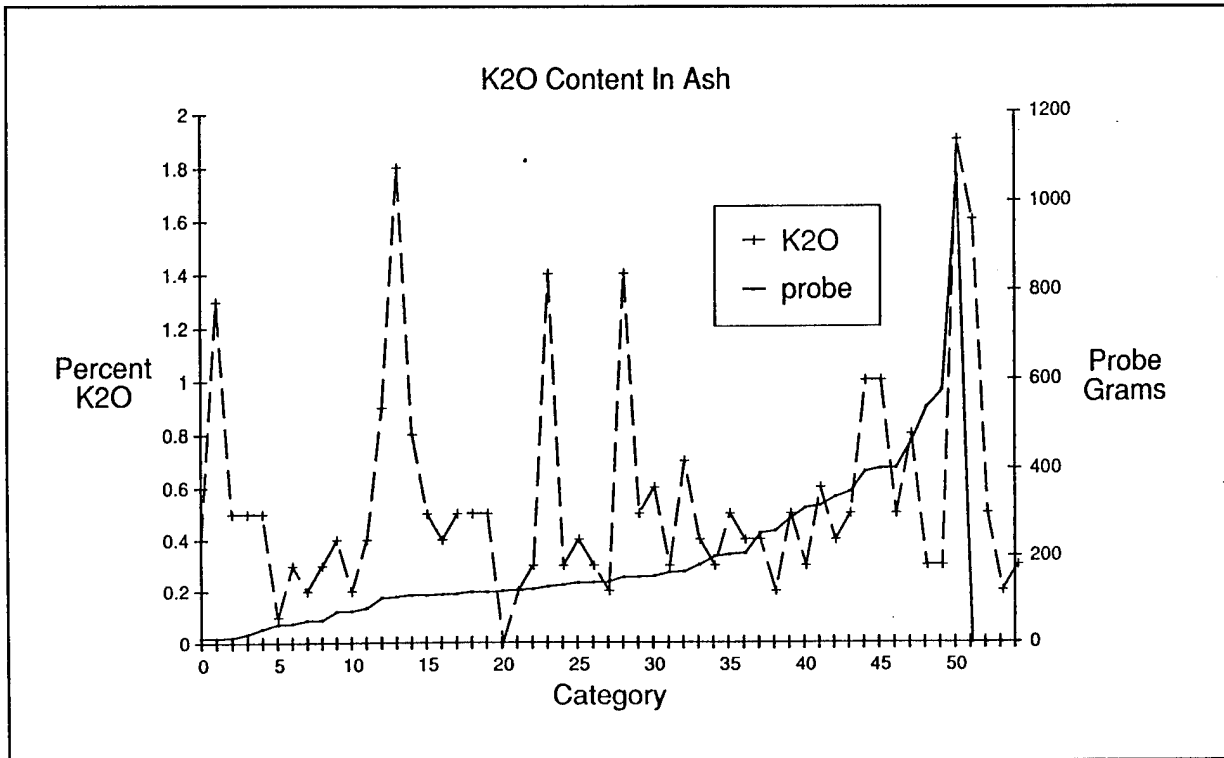

Figure 27. Correlation between fouling and K₂O content in ash.

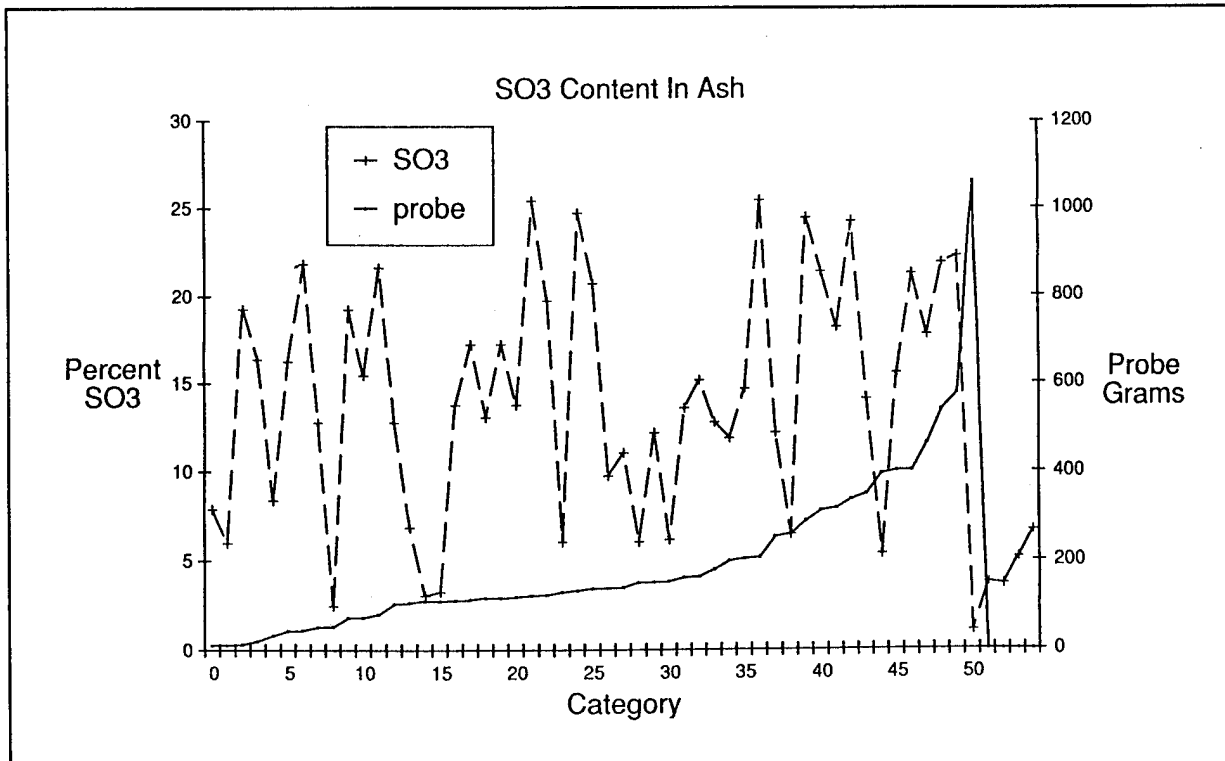

Figure 28. Correlation between fouling and SO₃ content in ash.

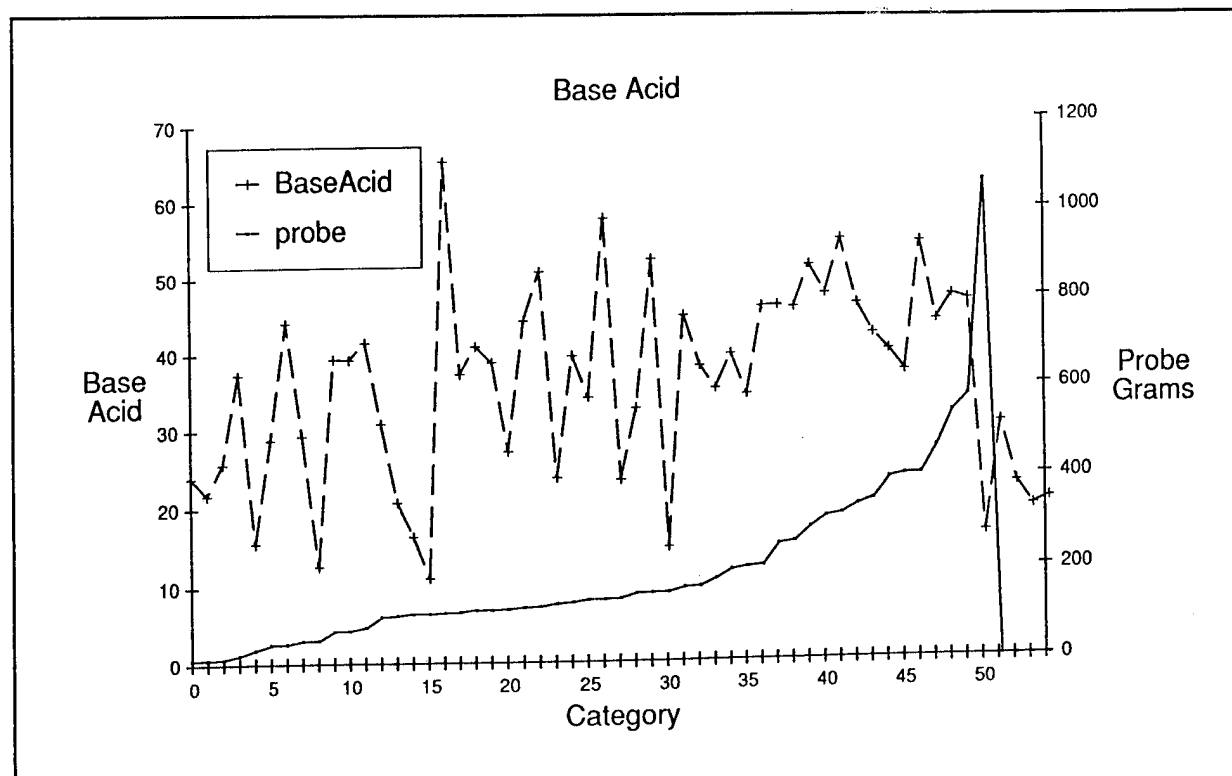

Figure 29. Correlation between the B/A ratio and probe weight.

In Figure 30, the ash percent is multiplied by the percent Na_2O in the ash and is graphed with probe weight. This value gives a closer fit than Na_2O alone. But it is still not good enough to use as an indicator for all coal's performance. Figure 31 shows no correlation between $\text{Fe}_2\text{O}_3/(\text{CaO} + \text{MgO})$ and probe weight.

Ash Deposition Factors

Borio and Levasseur (1984) listed the following fundamental considerations in ash deposition:

1. Coal organic properties
2. Coal mineral matter properties
3. Combustion kinetics
4. Mineral transformation and decomposition
5. Fluid dynamics
6. Ash transport phenomena
7. Vaporization and condensation of ash species
8. Deposit chemistry—species migration and reaction
9. Heat transfer to and from the deposit.

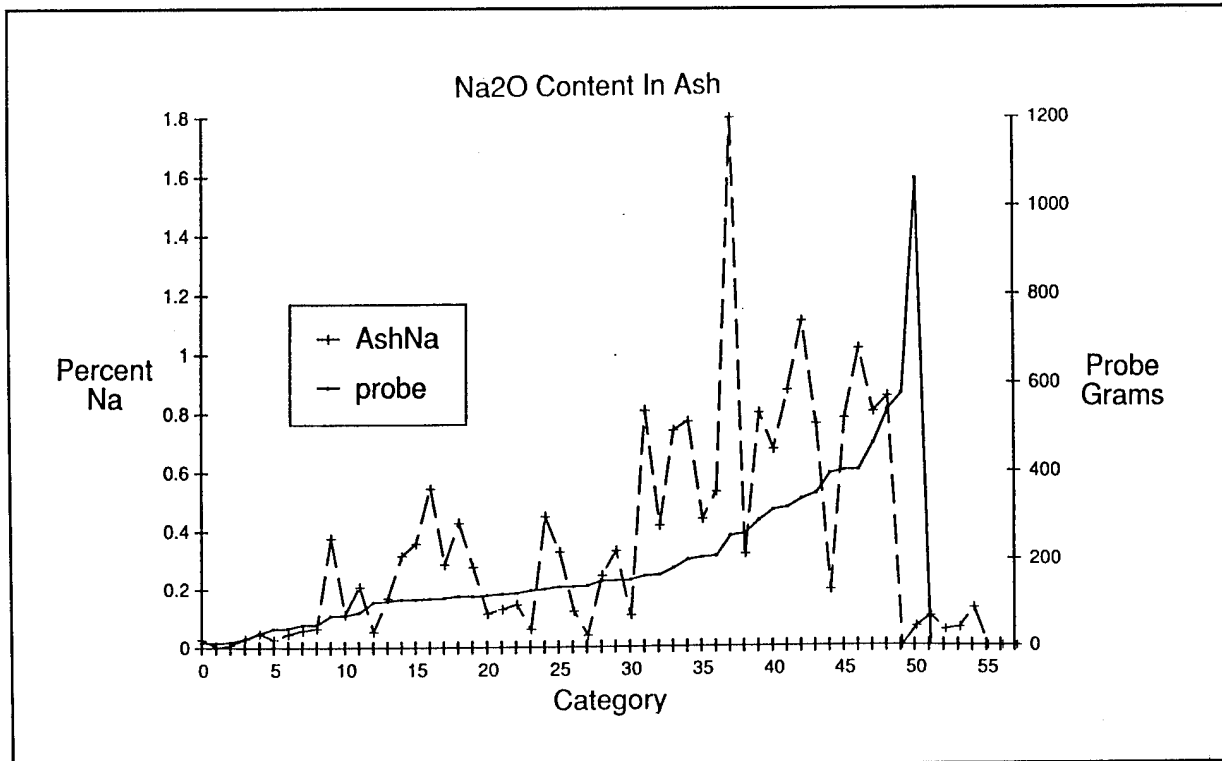

Figure 30. Correlation between percent Na₂O in the ash and probe weight.

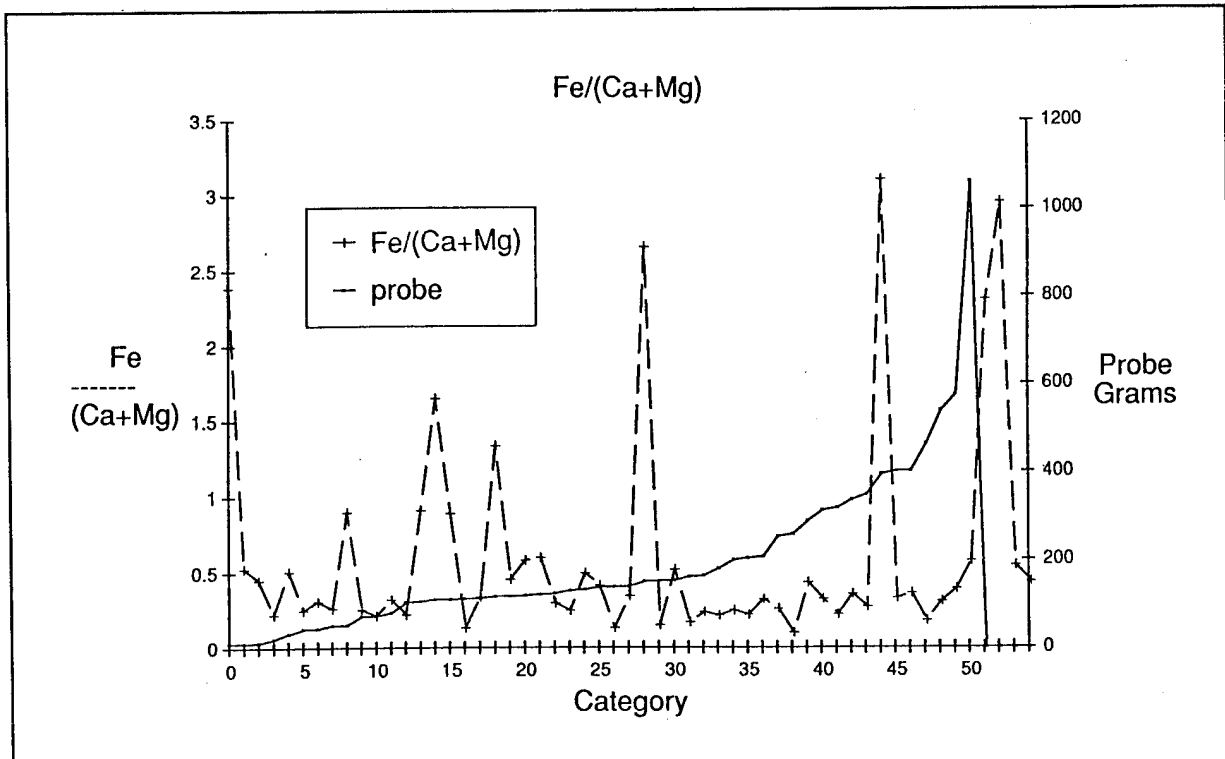

Figure 31. Correlation between the Fe₂O₃/(CaO + MgO) and probe weight.

No value can be set for a percent Na_2O in the ash that is low enough to assure low fouling potentials. Factors other than Na_2O must also be considered when fouling problems occur. As discussed earlier, many of these factors are not related to coal quality, but rather concern methods of coal handling, storage, and firing.

It should be noted that GFETC has classed the Decker mine to be low fouling at less than 8.5 percent Na_2O (Table 11). Test coal used at Malmstrom is much higher in Al_2O_3 than the average or the median for 55 samples used in this analysis. This alone will make the ash very refractory and low fouling, but it is unrealistic to insist on this particular combination of ash minerals when many others are satisfactory.

The importance of a complete ash analysis cannot be overemphasized. If there are problems with coal combustion in any type of furnace, a complete ash analysis, including evaluation of the above constituents, is recommended. While the absolute cause and effect relationships between minerals in the ash and combustion performance are not defined, general trends have been found that can help improve performance.

The importance of matching the proper coal to the combustion technology also cannot be overemphasized. Once a coal that works well in the furnace has been found, this specification should be adhered to as much as possible. It is further recommended that this coal be completely analyzed, including ash analysis, to establish a "fingerprint" of that coal. Such a practice will decrease operation and maintenance costs, increase efficiency, decrease the cost per pound of steam, and decrease emissions.

5 Conclusions and Recommendations

General Operation

Because there was not enough information available to determine the exact operating conditions during the convective section plugging that occurred in March 1986, conclusions are based on observations after the fact. The observations include: improper control of overfire air; inaccurate primary combustion air flow measurements; high opacities while firing on higher quality coal; flames in the convective section; inability to operate the unit at design outlet oxygen content; and subsequent successful testing of the unit with coal from the same coal pile used during the plugging problem.

Coal Quality

Subbituminous Western coal weathers poorly due to the nature of the coal and the local climate. As the coal dries in storage, the coal size is degraded, creating more fines. This was the major coal quality problem during the study. After the problem was identified, fresh coal was brought directly into overhead bunkers. This resulted in acceptable coal sizing at feeders. It is recommended that the required 90-day supply of reserve coal remain in outside storage but it should be protected from drying out by putting tarps over it or by putting some sealant material on it. The coal pile will have to be monitored with thermocouples, to look for the conversion of the small amount of sulfur in this Western coal and water into sulfuric acid, which can give a heat reaction sufficient to start a coal pile fire. The best way to control these hot spots is with CO_2 gas to displace the oxygen and cool down the hot spot in the pile. These hot spots could also be worked in with the coal that is hauled to the bunker and directly fired to the boiler.

The prime contractor, stoker manufacturer, and generator manufacturer thought the convective section plugging that occurred in March 1986 during unofficial testing was caused by the occurrence of high percentages of sodium in the coal. A review of technical literature showed some correlation between metals such as sodium and potassium and boiler fouling. This fouling is highly dependent on the ash fusion temperature of the coal. Both these metals tend to reduce the ash fusion temperature.

If the furnace temperature is maintained below the ash fusion temperature, fouling is less likely. To provide more information on the convection section plugging, a test of the Big Horn coal was conducted according to ASME Performance Test Code 4.1 on 19 June 1986. The test met capacity specifications and there were no signs of plugging. Inspection of the convective section after the test showed no slag formation.

A minor problem encountered in firing the Big Horn coal was caused by the low ash content of the coal. This required a gradual startup so a good ash bed could be developed to maintain an even airflow distribution through the coal, keep the grate cool, and control excess air. There should be at least 5 to 6 percent ash in coal to provide a good ash bed. The ash bed should be maintained at a minimum 4 to 5 in. thick.

Stoker/Furnace Design

Based on the official capacity tests, the stoker was designed for 656,000 Btu/sq ft of grate area. According to Schmidt and Associates, Inc., 650,000 Btu/sq ft is the recommended maximum design limit for Eastern bituminous coal, which is a very high quality coal. As coal quality is reduced, the Btu/sq ft must also be reduced. For subbituminous coal, the design should have been a maximum of 625,000 Btu/sq ft of grate area, or more conservatively, 600,000 Btu/sq ft. With the current design, this would reduce the boiler capacity from 85 to 80 MBtu/h heat output.

The HTWG was designed for 29,000 Btu/hr-cu ft, and specifications limited the furnace volume to a maximum of 30,000 Btu/hr-cu ft. According to Schmidt and Associates, Inc., good design practice would have limited it to 25,000. The ratio (of the recommended furnace volume) 25,000 Btu/cu ft and the 29,000 Btu/cu ft that the boiler is designed at indicates that the boiler is a 73.3 MBtu/h unit. During precompliance test operation of the plant, the generators ran well up to about 75 to 80 MBtu/h output. However, once the load exceeded 75 to 80 MBtu/h, it was necessary for expert operators to hand-fire the generator to meet performance requirements. The fuel distribution on the grate had to be perfect; on a daily basis, this sort of attention is not typical. Design parameters listed in specifications are best for use with a high quality Eastern bituminous coal.

Flyash Reinjection

Current design and operating practice reinjects about 50 percent of the flyash from the mechanical dust collector back into the furnace. Every few hours the mechanical dust

collector ash is pulled and sent to an ash handling system. There is no accurate method of metering or monitoring how much ash is reinjected. Flyash reinjection causes 30 percent more flyash in the flue gas with 30 to 40 percent of the particles less than 10 microns. Reinjection lines do not have great velocity, so they do not assist the overfire air system. Reinjection from the first pass hopper on a baffled furnace is acceptable because of the large particle size. However, reinjection from the mechanical collector is not a good design practice; most designs stopped using this technique 20 years ago. Stopping reinjection only costs about 1.5 percent efficiency. This is not a major concern because MAFB generators performed at 3.5 percent above the required efficiency.

Reinjected fly ash increases the opportunity for slagging problems because it increases the amount of flyash passing through the convective section. Since the reinjected flyash particles are at a higher temperature, those particles would tend to slag first. More important is the damage caused by the passing of the fly ash the second time over the tubes in the generator section.

Continuous reinjection of the fly ash will eventually result in an extremely small particle size that will bypass the mechanical collector into the spray dryer. Flyash reinjection will aggravate problems with ash carry-over into the SDA. During the initial official capacity tests, a control valve for the SDA ash recycling system clogged during operation at 100 percent MCR. Niro claimed that there was too much ash carry-over from the mechanical collector. The clogging was alleviated by closing the ash recirculation valve to increase the pressure and manually cleaning the valve via the access port. The clogging did not occur when mechanical collector ash hoppers were pulled hourly. The 1-in. ash recirculation valve was later replaced with a 1-1/2 in. valve and no clogging problems were reported. Increased pipe and nozzle damage will occur if flyash reinjection is continued; even carbon steel pipe can be destroyed by flyash.

Overfire Air System

High static pressures, around 45 in., are recommended to control nitric oxides and get good flyash burnout. Overfire air constitutes only about 17 percent of the total combustion air that comes into the boiler and is meant to provide turbulence to mix fuel and air. The oxygen in the overfire air is not needed to achieve complete combustion. A better design would use an overfire air fan that uses 50 percent hot flue gas (over 500 °F) and 50 percent ambient air. This would reduce excess air and allow more air flow through the fuel bed.

Undergrate Thermocouples

The generator was designed with three undergrate thermocouples, with only one at the back of the grate. A better placement of thermocouples would be on the two center rails about 2 ft in from the rear furnace wall and at intervals of one-third the length between the front and rear walls.

Opacity Monitors

One of the most important methods used in this project to fine tune the stokers was visual readings of the flue gas plume while the generator was on bypass. Tertiary APC equipment such as baghouses and electrostatic precipitators (ESPs) take this valuable tool away from the operators. But the generators cannot be taken off line each time the stokers need adjustment. The way to get around this is to place an opacity monitor before the baghouse. Minimizing opacity will decrease particulates in the flue gas, increase combustion efficiency, reduce carry over problems to the scrubber, and reduce loading on the baghouse.

Breeching Duct

The convective section outlet duct was over designed for the mechanical collector inlet. This causes flyash to settle out onto the duct and turning vanes. Reducing the duct diameter would increase the flue gas velocity and prevent this deposition problem.

Baghouse Design

During the pretests, the APC vendor was concerned about high air flow readings at the stack and was resistant to putting the baghouse on line because the airflows exceeded the manufacturer's maximum design flow rate. Design is 119,000 lb air/h at the scrubber inlet. To more thoroughly document the airflow problems, IBW contracted Clean Air Engineering to perform additional flow measurements at the boiler outlet, preheater outlet, and scrubber inlet. The flue gas flow rate (at 100 percent MCR) at the air heater outlet was 113,000 lb/h. This is within the design HTWG flue gas exit flow rate. Velocity traverses, after the baghouse and scrubber warmed up, showed a flow rate of 120,000 lb air/h going into the scrubber.

According to Schmidt and Associates, Inc., these low flow rates originate from the generator design that, in order to meet nitric oxide specifications, has to operate at

3.79 percent oxygen. During the official compliance tests, the oxygen levels in the flue gas ranged from 2.7 percent to 4.11 percent. This equates to 13.8 percent to 23.43 percent excess air. The oxygen predicted by the original design was 3.79 percent. These excess airs are more fitting to No. 6 oil burners. Typically, stokers operate at 30 to 40 percent excess air. Operating above or below this range will cause a higher carbon content in the flyash, more carbon to enter the spray dryer and the mechanical collector, and more material to reinject. The result will be increased carbon content in the flue gas that will increase erosion of tubes and baffles and spray dryer plugging problems.

During the Big Horn test, the air flow exiting the HTWG was within the design air flow. The air flow at the air preheater outlet was about 130,000 lb/h, which is 10,000 lb/h higher than the design maximum for the baghouse. The air preheater appears to have developed some early leaks. A review of Stanley Consultants' original drawings showed a design flow of 141,340 lb/h at the air heater outlet. This is substantially different from the as-built design rate of 119,000 lb/h.

The system was designed to run at 22 percent excess air, which is optimistic for this design. The baghouse was not designed with a large enough margin of error. At the lowest oxygen level during the official capacity tests, the baghouse airflow requirements were just met. A better design for the baghouse would have been a pulse-jet system instead of reverse air. Pulse-jet systems are better able to clean the sticky carbon particles from the filter bags. Current operating practices for baghouse cleaning cycles only require cleaning when the baghouse differential pressure reaches 9 in. of water. This will cause increased wear on the bags. The cleaning cycle should be changed to automatic cleaning at 5 in. of water.

References

Cited

- Borio, R.W., and A.A. Levasseur, "Overview of Coal Ash Deposition in Boilers," Proceedings of symposium on *Mineral Matter and Ash in Coal*, ACS Symposium Series 301 (American Chemical Society, 1986).
- Coal Fouling and Slagging Parameters*, ASME Research Committee on Corrosion and Deposits From Combustion Gases (American Society of Military Engineers [ASME], 1974).
- Combustion Engineering* (Combustion Engineering-Superheater, Inc., New York, NY, 1949).
- Honea, F.I., "Studies of Ash Fouling Potential and Deposit Strength in the GFETC Pilot Plant Test Furnace," paper presented at the Engineering Foundation Conference (12-17 July 1981).
- Honea, F.I., G.G. Montgomery, and M.L. Jones, "Recent Research on Ash Fouling in Combustion of Low Rank Coals," paper presented at the Eleventh Biennial Lignite Symposium (15-17 June 1981).
- Langsjoen, P.L., J.O. Burlingame, and J.E. Gabrielson, *Emissions and Efficiency Performance of Industrial Coal-Stoker-Fired Boilers*, EPA 600/7-81-111-12 (U.S. Environmental Protection Agency [USEPA], 1981).
- Levin, E.M., C.R. Robbins, and McMurdie, *Phase Diagrams for Ceramists* (American Ceramic Society, Inc., 1964).
- Manring, W.H., and W.C. Bauer, "Influence of Batch Preparation Process on the Melting and Firing of Glass," *Glass Industry* (July 1964), pp 354-358.
- Parmelee, Cullen W., *Ceramic Glazes*, 3d ed. (Harman Cahners Books Division, Cahners Publishing Co., 1973).
- Performance Test Code (PTC) 4.1, *Steam Generating Units (with 1968 and 1969 Addenda)* (ASME, 1964 [rev. 1985]).
- Potter, Phillip J., *Steam Power Plants* (The Ronald Press Company, 1949).
- Quann, R.J. and A.F. Sarofim, "Vaporization of Refractory Oxides During Pulverized Coal Combustion," *Proceedings of Symposium on Internal Combustion*, vol 19 (1982), pp 1492-1440.
- Wibberley and T.F. Wall, "Alkali-Ash Reactions and Deposit Formation in Pulverized-Coal-Fired Boilers: Experimental Aspects of Sodium Silicate Formation and the Formation of Deposits," *Fuel*, vol 61, No. 1 (1982), pp 93-99.

Uncited

Combustion, Fossil Power Systems (Combustion Engineering, Inc., 1981).

"Fuel and Ash Characteristics and its Effects on the Design of Industrial Boilers," Babcock & Wilcox Technical Paper presented to the American Power Conference, Chicago, IL (24-26 April 1978).

Honea, F.I., Selle, and E.A. Sondreal, *Factors Affecting Boiler Tube Fouling From Western and Gulf Coast Lignites and Subbituminous Coals* (National Association of Corrosion Engineers [NACE], 1986).

Karner, F.R., S.A. Benson, Harold H. Schobert, and R.G. Roaldson, "Geochemical Variation of Inorganic Constituents in a North Dakota Lignite," *American Chemical Society*, vol 28, No. 4 (28 Aug-2 Sept 1983).

1986 Annual Book of ASTM Standards, Section 5, "Petroleum Products, Lubricants and Fossil Fuels," Volume 05.05 *Gaseous Fuels; Coal and Coke* (ASTM, 1916 Race Street, Philadelphia, PA 19103).

Pelley, C.R., "Coal Buying Today—The Sellers Response," paper presented at the *Twenty-Seventh Annual Kentucky Industrial Coal Conference* (University of Kentucky, Lexington, KY, 13-14 April 1988).

"Power From Coal," *Power* (February, March, and April 1974).

USACERL DISTRIBUTION

Chief of Engineers
ATTN: CEHEC-IM-LH (2)
ATTN: CEHEC-IM-LP (2)
ATTN: CECC-R
ATTN: CERD-L

Seattle District
ATTN: CENPS-CO-CS
ATTN: CENPF-EN-NP/AF

Defense Tech Info Center 22304
ATTN: DTIC-FAB (2)

10
12/95