

NATIONAL AIR INTELLIGENCE CENTER



OPTIMAL DESIGN FOR A TYPE OF STRAP DOWN
TERMINAL GUIDANCE SYSTEM

by

(Illegible) Zhihong, Liu Linke

DTIC QUALITY INSPECTED 2



Approved for public release:
distribution unlimited

19960408 146

HUMAN TRANSLATION

NAIC-ID(RS)T-0624-95 8 February 1996

MICROFICHE NR: 96000073

OPTIMAL DESIGN FOR A TYPE OF STRAP DOWN TERMINAL GUIDANCE SYSTEM

By: (Illegible) Zhihong, Liu Linke

English pager: 25

Source: "Yi Zhong Jie Lian Mo Zhi Dao Xi Tong De You Hua She
Ji"; pp. 5-1 to 5-10

Country of origin: China

Translated by: SCITRAN
F33657-84-D-0165

Requester: NAIC/TASC/Richard A. Peden, Jr.
Approved for public release; distribution unlimited.

THIS TRANSLATION IS A RENDITION OF THE ORIGINAL FOREIGN TEXT WITHOUT ANY ANALYTICAL OR EDITORIAL COMMENT STATEMENTS OR THEORIES ADVOCATED OR IMPLIED ARE THOSE OF THE SOURCE AND DO NOT NECESSARILY REFLECT THE POSITION OR OPINION OF THE NATIONAL AIR INTELLIGENCE CENTER.	PREPARED BY: TRANSLATION SERVICES NATIONAL AIR INTELLIGENCE CENTER WPAFB, OHIO
--	---

GRAPHICS DISCLAIMER

All figures, graphics, tables, equations, etc. merged into this translation were extracted from the best quality copy available.

ABSTRACT This article studies a type of new model strap down terminal guidance system. It contains a strap down type guidance head, a set of strap down type inertial sensors, and in the three speed gyroscope and three line accelerometer are partially shared measurement components associated with navigation, guidance, and piloting instruments. The article presents a strap down terminal guidance design associated with the estimation of target status relative to missile movements in inertial coordinate systems, deriving the structures and mathematical models associated with the types of systems in question. It puts forward design algorithms for generalized Karman (phonetic) filters as well as optimal guidance patterns. Finally, use is made of digital simulations to empirically verify the feasibility of the systems in question to handle close range, highly maneuverable targets.

KEY WORDS Strap down terminal guidance system, Strap down type guidance head, Generalized Karman (phonetic) filter, Optimized guidance.

SYSTEM STRUCTURE AND OPERATIONAL PRINCIPLES

In order to be appropriate to the requirements associated with countering close range (under 5 kilometers) highly maneuverable (normal overload reaching 9g) aerial targets, on the one hand, use is made of guidance head technology progress achieved in the area of expanded instantaneous fields of vision. It is possible to make guidance heads get rid of universal frames and fix them directly to missile bodies. This kind of strap down type guidance head not only makes tracking angular velocities almost unlimited. It also increases system reliability. On the other hand, guidance system design bends every effort to present new structural arrangements, collecting, and, in conjunction with that, organizing and extracting as much information as possible, using microcomputers to introduce control systems, and constructing new models of guidance patterns in order to realize optimal guidance. The strap down terminal guidance system which this article studies opts for the use of a strap down type guidance head as well as a set of strap down type inertial sensors (including three velocity gyroscopes and three linear accelerometers) to act as measurement components. It is a new type of design facing precisely toward future combat.

The system structural diagram can be seen in Fig.1. The three gyroscopic velocity measurements associated with angular velocities p , q , and r along the x , y , and z axes of missile body coordinate systems go through directional cosine matrix integration. It is possible to obtain coordinate transform matrices between missile body coordinate systems and inertial coordinate systems. Accelerometers measure the three linear missile accelerations A_{mXb} , A_{myb} , and A_{mzb} along the three axes of the missile coordinate system. Strap down type guidance heads measure the angles of sight λ_{pb} and the azimuth angles λ_{yb} of targets in missile coordinate systems. In all cases, they go through coordinate transforms to create the linear accelerations A_{mxi} , A_{myi} , and A_{mzi} as well as the corresponding angles λ_{pi} and λ_{yi} in inertial coordinate systems. Use is made of A_{mxi} , A_{myi} , and A_{mzi} to act as input signals. λ_{pi} and λ_{yi} act as measurement signals. Going through generalized Karman (phonetic) filters, it is possible to do estimates--in inertial coordinate systems--of various parameter vectors such as missile-target relative positions SR , relative velocity VR , as well as target acceleration AT , and so on. These parameters are needed in the formation of optimum guidance commands. It is still necessary to take these parameters and transform them into missile coordinate systems. Use is made of the x axis components as well as measured missile acceleration values along missile axes in order to construct a type of relatively accurate flight time remaining t_{go} algorithm. The t_{go} in question is an important parameter in the formation of optimum guidance commands. Using the missile guidance commands obtained in inertial coordinate systems, A_{mxi} , A_{myi} , and A_{mzi} --through coordinate transformations--formation

is done of guidance commands A_{mcyb} and A_{mczb} (missile axis

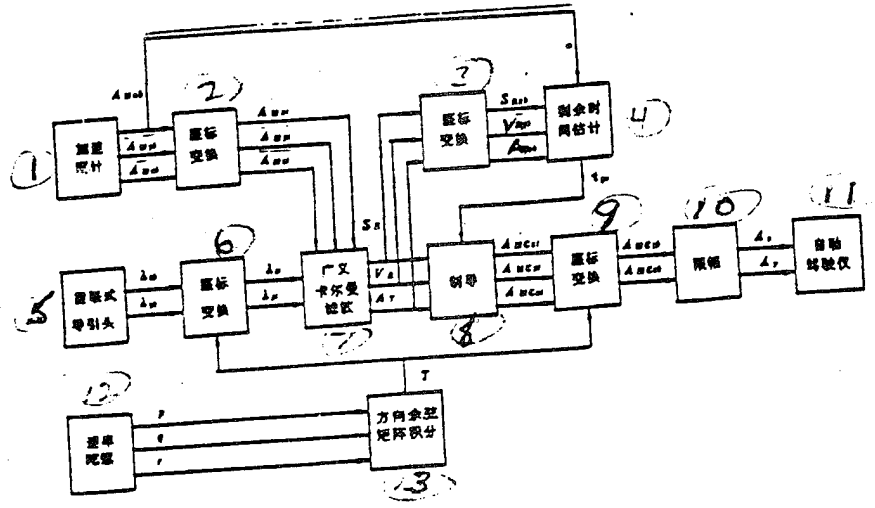

Fig.1 Guidance System Composition Schematic

- Key: (1) Accelerometer (2) Coordinate (illegible) Transform (3) Coordinate (illegible) Transform (4) Estimate of Time Remaining (5) Strap Down Type Guidance Head (6) Coordinate (illegible) Transform (7) Generalized Karman (phonetic) Filter (8) Guidance Transform (9) Coordinate (illegible) Transform (10) Amplitude Limitation (11) Automatic Pilot (12) Velocity Gyroscope (13) Directional Cosine Matrix Integration

directions not controlled) in missile coordinate systems. Then, amplitude limitation is applied to facilitate the output of the pitch channel and yaw channel commands A_p and A_y to the automatic pilot in order to control missile flight toward the target.

MATHEMATICAL SYSTEM MODELS

I. Coordinate Systems Used and Their Transform Relationships

As far as missile fuselage coordinate systems are concerned, they are firmly connected to the missile body. The origin point lies on the center of mass of the missile. x is the longitudinal axis along the missile. The z axis lies perpendicular to x in a plane of symmetry longitudinal along the missile. See Fig.2.

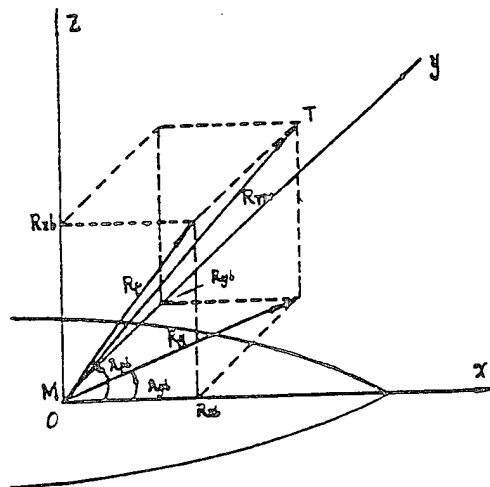

Fig.2 Missile Body Coordinate System as well as Angles of Sight and Azimuth Angles

As far as inertial coordinate systems are concerned, they are fixed immovable relative to the ground. They are a reference system associated with the movements of missiles and targets. Here, option is made for the missile body coordinate system at the instant of launch to act as inertial coordinate system.

Setting the coordinate transform matrix T_3^1 from inertial coordinate system to missile body coordinate system at the instant t to be

$$T_3^1 = \begin{pmatrix} l_1 & l_2 & l_3 \\ m_1 & m_2 & m_3 \\ n_1 & n_2 & n_3 \end{pmatrix} \quad (1)$$

the three lines of 1 stand respectively for the directional cosines associated with the three inertial coordinate system axes in the missile body coordinate system. Therefore, they have the designation of direction cosine matrix. Giving consideration to microrotational movements associated with the missile body, it is possible to deduce the microequations which should be satisfied by direction cosine matrices

$$\dot{T}_b^i = \begin{pmatrix} 0 & r & -q \\ -r & 0 & p \\ q & -p & 0 \end{pmatrix} T_b^i, \quad T_b^i|_{t=0} = I, \quad (2)$$

/5-3

In the equations, p , q , and r are measured by velocity gyroscopes. Making use of fourth order Longge-Kuta (phonetic) methods to make solutions, it is possible to obtain T_b^i for any instant.

II. Strap Down Type Guidance Heads

As far as measuring angles of sight and position angles of targets in missile body coordinate systems is concerned, see Fig.2. λ_{pb} is the included angle between the projection of target-missile relative position vector RTM in the plane xoz and the missile body longitudinal axis x . λ_{yb} is the included angle between the projection of RTM in the plane xoy and x . By geometrical relationships, one has

$$\lambda_{pb} = \tan^{-1} \frac{-R_{zb}}{R_{xb}} + V_{pb} \quad (3)$$

$$\lambda_{yb} = \tan^{-1} \frac{R_{yb}}{R_{xb}} + V_{yb}$$

In equations, R_{xb} , R_{yb} , and R_{zb} are the various axial projections of RTM in missile body coordinate systems. V_{pb} and V_{yb} are measured noise.

III. Conversion of Guidance Head and Linear Accelerometer Information

Completely, or making use of Karman (phonetic) filters to calculate estimates for missile-target relative motion states in

inertial coordinate systems, it is necessary to take information measured by guidance heads and linear accelerometers in inertial coordinate systems and convert it into information in inertial coordinate systems. Due to the orthogonal nature of direction cosine matrices, the coordinate transfer matrix T_i^b from missile body coordinate systems to inertial coordinate systems is nothing else than

$$T_i^b = (T_b^i)^T = \begin{pmatrix} l_1 & m_1 & n_1 \\ l_2 & m_2 & n_2 \\ l_3 & m_3 & n_3 \end{pmatrix} \quad (4)$$

Therefore, the vectors A_{mb} and R_{TMB} in missile body coordinate systems--in inertial coordinate systems--are

$$\left. \begin{aligned} A_{mi} &= T_i^b \cdot A_{mb} \\ R_{Tmi} &= T_i^b \cdot R_{Tmb} \end{aligned} \right\} \quad (5)$$

The three component vectors associated with R_{Tmi} and R_{Tmb} are

$$\left. \begin{aligned} R_{Tmi} &= [R_{xi} \quad R_{yi} \quad R_{zi}]^T \\ R_{Tmb} &= [R_{xb} \quad R_{yb} \quad R_{zb}]^T \end{aligned} \right\} \quad (6)$$

Therefore, one has

$$\left. \begin{aligned} R_{xi} &= l_1 R_{xb} + m_1 R_{yb} + n_1 R_{zb} \\ R_{yi} &= l_2 R_{xb} + m_2 R_{yb} + n_2 R_{zb} \\ R_{zi} &= l_3 R_{xb} + m_3 R_{yb} + n_3 R_{zb} \end{aligned} \right\} \quad (7)$$

Because of this, angles of sight and position angles measured by guidance heads in inertial coordinate systems are

$$\lambda_{pi} = t_g^{-1} \frac{-R_{zi}}{R_{xi}} + V_{pi}$$

$$= t_g^{-1} \frac{-\ell_1 - m_1 \cdot t_g \lambda_{yb+n_1} \cdot t_g \lambda_{pb} + V_{pi}}{\ell_1 + m_1 \cdot t_g \lambda_{yb-n_1} \cdot t_g \lambda_{pb}}$$

$$\lambda_{yi} = t_g^{-1} \frac{-y_i}{R_{xi}} + V_{yi} \quad (8)$$

$$= t_g^{-1} \frac{\ell_2 + m_2 \cdot t_g \lambda_{yb-n_2} \cdot t_g \lambda_{pb}}{\ell_2 + m_2 \cdot t_g \lambda_{yb-n_2} \cdot t_g \lambda_{pb}} + V_{yi} \quad /5-4$$

By the same reasoning, the three components of AMi and AMb are, respectively

$$A_{mi} = [A_{mxi} \quad A_{myi} \quad A_{mzi}]^T \quad (9)$$

$$A_{mb} = [A_{mxb} \quad A_{myb} \quad A_{mzb}]^T$$

By contrast, the various components associated with linear accelerometers in inertial coordinate systems are

$$A_{mxi} = \ell_1 A_{mxb} + m_1 A_{myb} + n_1 A_{mzb}$$

$$A_{myi} = \ell_2 A_{mxb} + m_2 A_{myb} + n_2 A_{mzb}$$

$$A_{mzi} = \ell_3 A_{mxb} + m_3 A_{myb} + n_3 A_{mzb}$$
(10)

IV. Designs Associated with Generalized Karman (phonetic) Filters

In order to satisfy the creation of optimum guidance, there

is a need for information associated with all the various vectors for missile-target relative positions SR ($SR = RTM$), relative velocities VR , as well as target accelerations AT . Moreover, these status variables are not able to be measured by systems on missiles. There is a need for additional calculations. Use is made of strap down guidance head linearization as well as information measured by linear accelerometers in inertial coordinate systems. Moreover, giving consideration to the existence of noise, there is a need to design generalized Karman (phonetic) filters in order to calculate these states in inertial coordinate systems.

The micro equations which the three vectors SR , VR , and AT which await solution, satisfy are determined by missile-target relative motion equations. That is, equations of state associated with generalized Karman (phonetic) filter problems are

$$\begin{aligned}\dot{S}_R &= V_R \\ \dot{V}_R &= A_T - A_M + \ddot{w}_M \\ \dot{A}_T &= -\lambda A_T + \ddot{w}_T\end{aligned}\tag{11}$$

In the equations, WM and WT are, respectively, acceleration process noises associated with missiles and targets. Here, described target mechanical characteristics are shown using first order Markoff (phonetic) processes. Written as matrices, one forms

$$\dot{X} = FX + GA_M + \Gamma \ddot{w}\tag{12}$$

In equations,

$$\begin{aligned}X &= \begin{pmatrix} S_R \\ V_R \\ A_T \\ 0 \end{pmatrix} & F &= \begin{pmatrix} 0 & I_3 & 0 \\ 0 & 0 & I_3 \\ 0 & 0 & -\lambda I_3 \\ 0 & 0 & 0 \end{pmatrix} \\ G &= \begin{pmatrix} 0 \\ -I_3 \\ 0 \end{pmatrix} & \Gamma &= \begin{pmatrix} I_3 & 0 \\ 0 & I_3 \end{pmatrix} & W &= \begin{pmatrix} W_M \\ W_T \end{pmatrix}\end{aligned}$$

In order to facilitate digital control, the particularized state

equation is

$$\begin{aligned} x(k+1) = & \phi(k+1, k)x(k) + G(k+1, k)A_m(k) \\ & + \Gamma(k+1, k)W(k) \end{aligned} \quad (13)$$

In equations,

$$\phi(k+1, k) = \begin{pmatrix} I & I \cdot \Delta t & I \cdot (e^{-\lambda \cdot \Delta t} + \lambda \cdot \Delta t - 1) / \lambda^2 \\ 0 & I & I \cdot (1 - e^{-\lambda \cdot \Delta t}) / \lambda \\ 0 & 0 & I \cdot e^{-\lambda \cdot \Delta t} \end{pmatrix}$$

$$G(k+1, k) = [-I \cdot \Delta t^2 / 2 \quad -I \cdot \Delta t \quad 0]^T$$

$$\Gamma(k+1, k) = \begin{pmatrix} I \cdot \Delta t^2 / 6 & I \cdot (1 - \lambda \cdot \Delta t + \lambda^2 \cdot \Delta t^2 - e^{-\lambda \cdot \Delta t}) / \lambda^3 & 0 \\ I \cdot \Delta t & I \cdot (-1 + \lambda \cdot \Delta t + e^{-\lambda \cdot \Delta t}) / \lambda^2 & 0 \\ 0 & I \cdot (1 - e^{-\lambda \cdot \Delta t}) / \lambda & 0 \end{pmatrix}$$

$$\Delta t = t_{k+1} - t_k = T \quad \begin{array}{l} \text{Sampling} \\ \text{(采样周期),} \\ \text{Cycle etc} \end{array}$$

From the point of view of convenience, take the state vector x and expand it. In conjunction with that, record it simply as

$$x = [S_R^T \ V_R^T \ A_T^T]^T = [S_{Rx_i} \ S_{Ry_i} \ S_{Rz_i} \ V_{Rx_i} \ V_{Ry_i} \\ V_{Rz_i} \ A_{Tx} \ A_{Ty} \ A_{Tz}]^T \\ \Delta = [x_1 \ x_2 \ x_3 \ \dots \ x_n]^T$$

(14)

Moreover,

$$[S_{Rx_i} \ S_{Ry_i} \ S_{Rz_i}] = [R_{xi} \ R_{yi} \ R_{zi}] \quad (15)$$

Because of this, strap down type guidance head equations can be written into the matrix form

(16)

$$Z = h(x) + V$$

In equations,

$$Z = \begin{pmatrix} \lambda_{pi} \\ \lambda_{yi} \end{pmatrix}, \quad h(x) = \begin{pmatrix} h_1(x) \\ h_2(x) \end{pmatrix} = \begin{pmatrix} t_g^{-1} \frac{-x_2}{x_1} \\ t_g^{-1} \frac{x_2}{x_1} \end{pmatrix}$$

$$V = \begin{pmatrix} v_{pi} \\ v_{yi} \end{pmatrix}$$

For the sake of its linearization and particularization, around predicted state $\hat{x}(k+1/k)$ expand a Taylor series, and, in conjunction with that, omit the various second and higher order terms. It is possible to obtain the observational equation

$$Z(k+1) = H(k+1)x(k+1) + Y(k+1) + V(k+1) \quad (17)$$

/5-6

In equations, the observational matrix $H(k+1)$ is

$$H(k+1) = \left. \frac{\partial h(x)}{\partial x^T} \right|_{\hat{x}(k+1/k)} = \begin{pmatrix} \frac{\partial h_1}{\partial x_1} & 0 & \frac{\partial h_1}{\partial x_2} & 0 & \dots & 0 \\ \frac{\partial h_2}{\partial x_1} & \frac{\partial h_2}{\partial x_2} & 0 & 0 & \dots & 0 \end{pmatrix}_{2 \times 6}$$

$$\frac{\partial h_1}{\partial x_1} = \frac{x_2}{x_1^2 + x_2^2}, \quad \frac{\partial h_1}{\partial x_2} = -\frac{x_1}{x_1^2 + x_2^2}$$

$$\frac{\partial h_2}{\partial x_1} = -\frac{x_2}{x_1^2 + x_2^2}, \quad \frac{\partial h_2}{\partial x_2} = \frac{x_1}{x_1^2 + x_2^2}$$

$$Y(k+1) = h[\hat{x}(k+1/k)] - H(k+1)\hat{x}(k+1/k)$$

After obtaining linearized and particularized equations of state and observational equations, on the basis of the theory of optimization calculations, it is possible to obtain the generalized Karman (phonetic) filter equations possessing input signals (AM (k)) as the equation set presented below

$$\begin{aligned}
 \hat{x}(k+1/k) &= \phi(k+1, k) \hat{x}(k/k) \\
 &\quad + G(k+1, k) A_k(k) \\
 P(k+1/k) &= \phi(k+1, k) P(k/k) \phi^T(k+1/k) \\
 &\quad + \Gamma(k+1, k) Q_k \Gamma^T(k+1, k) \\
 K(k+1) &= P(k+1/k) H^T(k+1) \\
 &\quad \cdot [H(k+1) P(k+1, k) H^T(k+1) + R_{k+1}]^{-1} \\
 \hat{x}(k+1/k+1) &= \hat{x}(k+1/k) \\
 &\quad + K(k+1) [Z(k+1) - \hat{h}(k+1/k)] \\
 P(k+1/k+1) &= [I - K(k+1) H(k+1)] \cdot P(k+1/k)
 \end{aligned} \tag{18}$$

In equations

$$Q_k = E\{W_k \cdot W_k^T\} \quad , \quad R_k = E\{V_k \cdot V_k^T\}$$

V. Derivation of Optimum Guidance Patterns

In order to facilitate initial research--when deriving optimum guidance patterns--automatic pilots and missile body inertias are temporarily ignored. Because of this, equations of state associated with controlled objects are then nothing else than target-missile relative motion equations. Taking the vector microequations in question and expanding them, it is possible to obtain 9 scalar equations. They are capable--in accordance with the three axes of inertial coordinate systems--of being divided into three microequation sets associated with solution pairs. In all cases, each set of equations has the general form /5-7

$$\begin{pmatrix} \dot{S}_r \\ \dot{V}_r \\ \dot{a}_r \end{pmatrix} = \begin{pmatrix} 0 & 1 & 0 \\ 0 & 0 & 1 \\ 0 & 0 & -\lambda \end{pmatrix} \begin{pmatrix} S_r \\ V_r \\ a_r \end{pmatrix} + \begin{pmatrix} 0 \\ -1 \\ 0 \end{pmatrix} a_m \triangleq Fx + Gu \quad (19)$$

Selection is made of the second order form of performance index function set out below

$$J = \frac{1}{2} x^T(t_f) P(t_f) x(t_f) + \frac{1}{2} \int_0^{t_f} u^T R u dt \quad (20)$$

In equations,

$$P(t_f) = \begin{pmatrix} k & & \\ & 0 & \\ & & 0 \end{pmatrix}, \quad R = 1$$

It is possible to solve for optimum control as

$$u = \frac{3ktg_0}{3+k \cdot tg_0} \cdot \left[S_r + tg_0 \cdot V_r + \frac{e^{-\lambda \cdot tg_0} + \lambda \cdot tg_0 - 1}{\lambda^2} \cdot a_r \right] \quad (21)$$

(THIS PAGE INTENTIONALLY LEFT BLANK)

That is nothing else than to say that optimum guidance commands along the three inertial coordinate system axes are

$$A_{xji} = \frac{3k \cdot t_{g0}}{3+k \cdot t_{g0}^2} \cdot [S_{xji} + t_{g0} \cdot V_{xji} + \frac{e^{-\lambda \cdot t_{g0}} + \lambda \cdot t_{g0} - 1}{\lambda^2} \cdot A_{rji}]$$

$j = x, y, z$

(22)

In order to make target miss quantities as small as possible, selection should be made of $k \rightarrow \infty$. Therefore, option is made for the use of optimum guidance patterns which are

$$A_{xji} = 3 \left[\frac{S_{xji}}{t_{g0}^2} + \frac{V_{xji}}{t_{g0}} + \frac{e^{-\lambda \cdot t_{g0}} + \lambda \cdot t_{g0} - 1}{\lambda^2 \cdot t_{g0}^2} \cdot A_{rji} \right]$$

$j = x, y, z$

(24)

In equations, $t_{g0} = t_f - t$, designated flight time remaining.

When consideration is given to missile body and automatic pilot inertias, as far as optimum guidance patterns are concerned, there still exist functional relationships with variables of state related to missile bodies and automatic pilots. Expressions associated with A_{xji} will be much more complicated.

VI. Estimates of Time Remaining

From the derivations discussed above, it is obvious that there is a close relationship between guidance commands and time remaining t_{g0} . During the derivation of guidance commands, if one takes target-missile relative motion equations and--in accordance with the three axes of missile body coordinate systems--divides them into three microequation sets associated with solution pairs, it can lead to the formation of completely

similar guidance patterns in missile body coordinate systems,
 which are /5-8

$$A_{Mjb} = j \left[\frac{S_{Rjb}}{t_{g0}^2} + \frac{V_{Rjb}}{t_{g0}} + \frac{e^{-\lambda \cdot t_{g0} + \lambda \cdot t_{g0} - 1}}{\lambda^2 \cdot t_{g0}^2} \cdot A_{Rjb} \right] \quad (24)$$

$j = x, y, z$

Setting out the equation along missile axis x, it is a one dimensional quadratic equation in t_{g0} . It is possible to solve for the calculation formula for t_{g0} as

$$t_{g0} = \frac{2S_{Rxb}}{-V_{Rxb} + \sqrt{V_{Rxb}^2 + \frac{4}{3} \cdot S_{Rxb} \cdot (A_{Mxb} - 3K'_x \cdot A_{Rxb})}} \quad (25)$$

In equations,

$$K'_x = \frac{e^{-\lambda \cdot t_{g0} + \lambda \cdot t_{g0} - 1}}{\lambda^2 \cdot t_{g0}^2} \quad | \quad t_{g0} = t_f - t + \Delta t$$

that is, in K'_x , the t_{g0} uses the t_{g0} calculated for the instant before it to replace it. Therefore, after generalized Karman (phonetic) filters calculate SR, VR, and AT in inertial coordinate systems, it is necessary to go through coordinate

transformations into corresponding components in missile axis directions. Again making use of acceleration values measured in missile axis directions, it is then possible to calculate t_{go} .

VII. Formation of Control Commands

Control commands obtained in inertial coordinate systems need to go through coordinate transfer matrix T_B^i to be control commands in missile body coordinate systems. In conjunction with this, consider the missile's largest normal acceleration to be A . Then, amplitude limited control commands outputted to automatic pilots are

$$\left. \begin{aligned} A_p &= A \cdot \frac{A_{Mz} b}{\sqrt{A_{My}^2 b + A_{Mz}^2 b}} && \left. \begin{array}{l} \text{pitch} \\ \text{(俯仰通道)} \\ \text{channel} \end{array} \right\} \\ A_y &= A \cdot \frac{A_{My} b}{\sqrt{A_{My}^2 b + A_{Mz}^2 b}} && \left. \begin{array}{l} \text{yaw} \\ \text{(偏航通道)} \\ \text{channel} \end{array} \right\} \end{aligned} \right\} \quad (26)$$

NUMERICAL SIMULATION RESULTS

In order to study the performance of the strap down terminal guidance design in question, ballistic numerical simulation calculations were carried out on a few typical target motion situations. In simulations, it is assumed that automatic pilot and missile body inertias are not calculated. Velocity gyroscope outputs are regarded as a white noise process. During simulations, following along with alterations in missile-target relative distances r , guidance system sampling cycles Δt are

$$\Delta t = \begin{cases} 0.02 \text{ s} & r > 100 \text{ m} \\ 0.005 \text{ s} & 10 < r < 100 \text{ m} \\ 0.0005 \text{ s} & r < 10 \text{ m} \end{cases}$$

On the basis of reference [1], the power spectrum density matrices $R(t)$ and $Q(t)$ associated with observation noise and process noise in generalized Karmen (phonetic) filters are selected to be /5-9

$$R(t) = \text{diag} \left\{ \frac{0.25}{r} + 56.25 \times 10^{-3}, \frac{0.25}{r} + 56.25 \times 10^{-3} \right\}$$

$$R(k) = \frac{R(t)}{\Delta t}$$

$$Q(t) = \text{diag} \{ 1 \ 1 \ 1 \ 2500 \ 2500 \ 2500 \}$$

$$Q(k) = \frac{Q(t)}{\Delta t}$$

Initial values for relative missile-target positions as well as relative velocities are replaced with actual values. Target velocity initial values are 0 (illegible), $\lambda = 1$. The initial value $P(\%)$ of calculation error variance matrices is

$$P(\%) = \text{diag} \{ 0 \ 0 \ 0 \ 1 \ 1 \ 1 \ 2 \ 5 \ 0 \ 0 \ 2 \ 5 \ 0 \ 0 \ 2 \ 5 \ 0 \ 0 \}$$

Two typical target movement situations are presented here. Situation I. Target is in linear flight at uniform speed in inertial coordinate system. Velocities along x, y, and z axes are, respectively, 300, 50, and 50 m/s. The launch distance is 2500m. Situation II. Target is in high maneuver flight within inertial coordinate system. Accelerations along y and z axes

are both 50m/s^2 . Initial velocity is 300 m/s . In the two types of situations, missiles are aimed and launched along the x axis. Missile speed is 800 m/s .

Target miss quantity calculation results in inertial coordinate system are

情况 ①	总量 ②	分 ③ 量		
I	0.72m	$x = 0.06\text{m}$	$y = 0.56\text{m}$	$z = 0.45\text{m}$
II	2.00m	$x = 0.41\text{m}$	$y = 1.51\text{m}$	$z = 1.25\text{m}$

(1) Situation (2) Overall Amount (3) Components

Fig.3 presents estimated value curves associated with Situation I generalized Karmen (phonetic) filters. In order to facilitate comparison, actual values are drawn on the same graph. Situations of change associated with missile control commands are also given. Fig.4 is calculation results corresponding to Situation II.

Conclusions. The strap down terminal guidance design in question is appropriate for countering close range, highly maneuverable targets. The digital models are reasonable. Generalized Karmen (phonetic) filters are capable of relatively accurately estimating missile-target relative movement states as well as target movement states. Methods for estimating time remaining are comparatively good. Optimum guidance patterns are workable. With regard to optimum guidance problems associated with the consideration of automatic pilot and missile body inertias, it is planned to carry out research in another article.

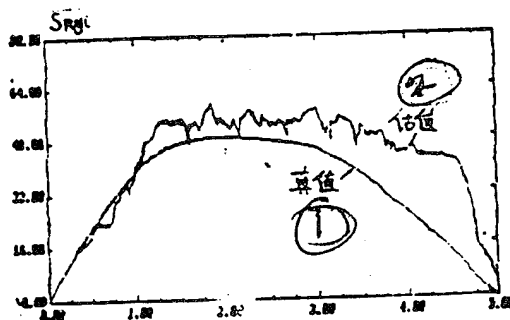

Fig.3 (a) Key: (1) Actual Value (2) Estimated Value

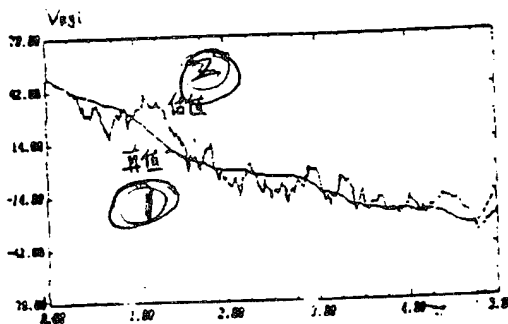
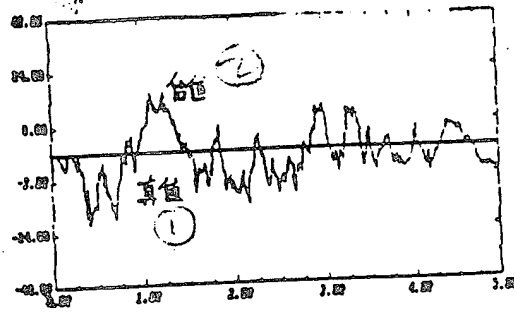

Fig.3 (b) Key: (1) Actual Value (2) Estimated Value



/5-10

Fig.3(c) Key: (1) Actual Value (2) Estimated Value

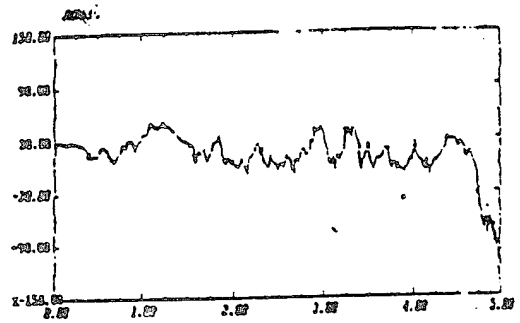

Fig.3(d)

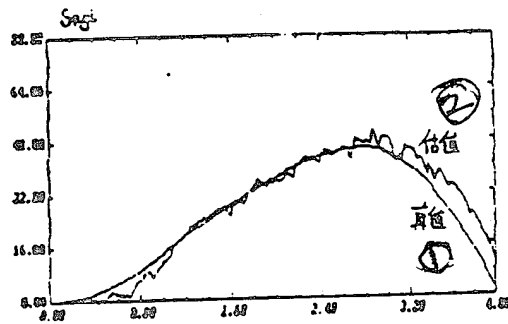

Fig.4(a) Key: (1) Actual Value (2) Estimated Value

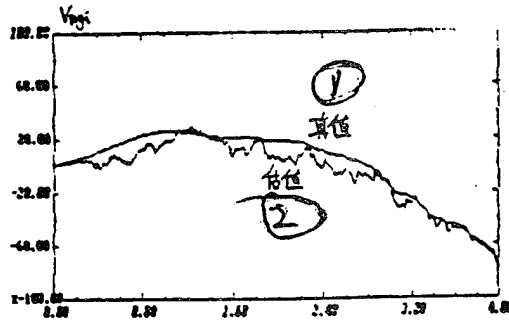

Fig.4(b) (1) Actual Value (2) Estimated Value

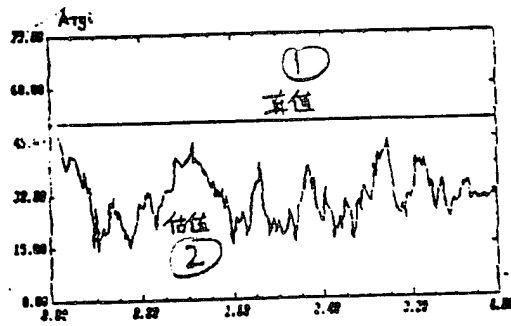
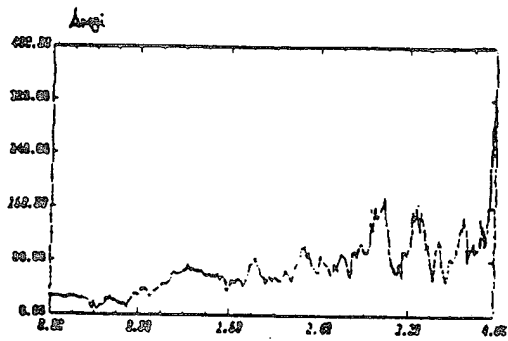

Fig.4(c) (1) Actual Value (2) Estimated Value

Fig.4(d)



REFERENCES

- [1] P.L.Vergez and J.R.McClendon, (Optimal Control and Estimation for Strapdown Seeker Guidance of Tactical Missiles), N82-17254, Feb 1982.
- [2] Douglas E.Williams, Jack Richman and Bernard Friedland, (Design of an Integrated Strapdown Guidance and Control System for a Tactical Missile), AIAA 83-2196, 1983.

DISTRIBUTION LIST

DISTRIBUTION DIRECT TO RECIPIENT

ORGANIZATION	MICROFICHE
B085 DIA/RTS-2FI	1
C509 BALLOC509 BALLISTIC RES LAB	1
C510 R&T LABS/AVEADCOM	1
C513 ARRADCOM	1
C535 AVRADCOM/TSARCOM	1
C539 TRASANA	1
Q592 FSTC	4
Q619 MSIC REDSTONE	1
Q008 NTIC	1
Q043 AFMIC-IS	1
E404 AEDC/DOF	1
E410 AFDIC/IN	1
E429 SD/IND	1
P005 DOE/ISA/DDI	1
1051 AFIT/LDE	1
PO90 NSA/CDB	1

Microfiche Nbr: FTD96C000073
NAIC-ID(RS)T-0624-95