

AFML-TR-73-145
Volume I

INTERACTIVE PROGRAM IN ADVANCED COMPOSITES TECHNOLOGY: PROGRAM REVIEW

T. A. CRUSE

DTIC QUALITY INSPECTED 4

TECHNICAL REPORT AFML-TR-73-145 Volume I

SEPTEMBER 1973

Approved for public release: distribution unlimited

AIR FORCE MATERIALS LABORATORY
AIR FORCE SYSTEMS COMMAND
WRIGHT PATTERSON AIR FORCE BASE, OHIO

19960329 001

PLASTIC 19658

DISCLAIMER NOTICE

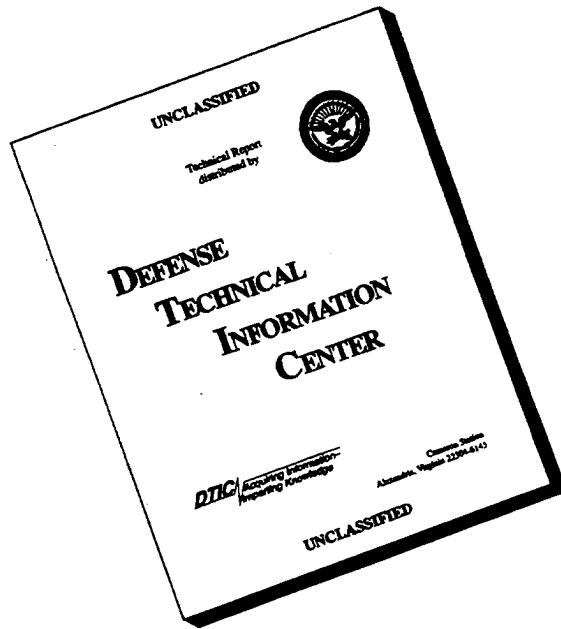

THIS DOCUMENT IS BEST QUALITY AVAILABLE. THE COPY FURNISHED TO DTIC CONTAINED A SIGNIFICANT NUMBER OF PAGES WHICH DO NOT REPRODUCE LEGIBLY.

NOTICE

When Government drawings, specifications, or other data are used for any purpose other than in connection with a definitely related Government procurement operation, the United States Government thereby incurs no responsibility nor any obligation whatsoever; and the fact that the government may have formulated, furnished, or in any way supplied the said drawings, specifications, or other data, is not to be regarded by implication or otherwise as in any manner licensing the holder or any other person or corporation, or conveying any rights or permission to manufacture, use, or sell any patented invention that may in any way be related thereto.

Copies of this report should not be returned unless return is required by security considerations, contractual obligations, or notice on a specific document.

AFML-TR-73-145
Volume I

INTERACTIVE PROGRAM IN ADVANCED COMPOSITES TECHNOLOGY: PROGRAM REVIEW

T. A. CRUSE

TECHNICAL REPORT AFML-TR-73-145 Volume I

SEPTEMBER 1973

Approved for public release: distribution unlimited

AIR FORCE MATERIALS LABORATORY
AIR FORCE SYSTEMS COMMAND
WRIGHT PATTERSON AIR FORCE BASE, OHIO

FOREWARD

This report describes work performed in the Department of Mechanical Engineering, Carnegie-Mellon University, Pittsburgh, Pennsylvania, 15213, under Air Force Contract F33615-72-C-1214, Project 6169 CW; Subject: "Development of Design and Analytical Techniques for Advanced Composite Aircraft Structures." This work was accomplished between 1 November 1971 and 31 August 1973. The Project Engineers for the Air Force Materials Laboratory were Mr. George E. Husman and Mr. Robert M. Neff, AFML/LC. The research projects in this report were undertaken by several graduate students under the direction of Dr. T. A. Cruse, the Principal Investigator. Chapters II-IV in Volume I were prepared by Messers. David Gamret, Mark Emerson, and Warren Bamford, respectively. Volume II is the Ph.D. Dissertation of Dr. J. P. Waszczak; Volume III is the Ph.D. Dissertation of Dr. H. J. Konish, Jr.

The authors wish to acknowledge the active support of various engineers in industry; particularly the support of Messers. M. E. Waddoups, C. W. Rogers, J. E. Eisenman, B. E. Kaminski, and Dr. D. J. Wilkins of General Dynamics, Fort Worth, Texas. We also wish to acknowledge the assistance of the Project Engineers and Dr. J. C. Halpin of the Air Force Materials Laboratory.

This report was submitted on 31 May (Volumes II, III) and 31 August (Volume I), 1973.

This technical report has been reviewed and is approved.



Robert C. Tomashot
Technical Area Manager
Advanced Composites Division

ABSTRACT

The Carnegie-Mellon University team has completed the second two year program in advanced composites technology. The program has had significant impact in several areas as the CMU team, working closely with the engineers at General Dynamics, Convair Aerospace Division, Fort Worth, has continued work on several projects. The work reported herein included: continuing development of university-industry interaction; development of educational material including reports on manufacturing methods, Weibull statistics, and stresses due to an elliptical hole in an anisotropic plate; and, advanced research into synthesis procedures for mechanically fastened joints and elastic fracture mechanics for laminated composite plates. The research projects demonstrate useful design capabilities, new analytic and numerical results, and experimental data.

INTERACTIVE PROGRAM IN ADVANCED COMPOSITES TECHNOLOGY:

PROGRAM REVIEW

TABLE OF CONTENTS

I. SUMMARY OF THE PROGRAM	
1.1 Introduction	1
1.2 Research Results of the Program	3
1.3 Conclusions	4
II. FABRICATION PRACTICES AND PROBLEMS FOR BORON AND GRAPHITE EPOXY	
2.1 Introduction	6
2.2 Tooling	7
2.3 Lay-Up	10
2.4 Curing Process	24
2.5 Machining Problems	28
2.6 Conclusions	31
III. A COMPUTER PROGRAM FOR WEIBULL STATISTICS	
3.1 Review of Weibull Statistics	32
3.2 Detailed Program Description	36
3.3 Program Description	51
3.4 Sequence of Program Operations	52
3.5 Program Variables	55
3.6 Sample Output	57
IV. TENSION OF AN ANISOTROPIC PLATE WITH ELLIPTIC CUTOUT	
4.1 Introduction	65
4.2 Problem Solution: First Problem	65
4.3 Program Listing	72

LIST OF ILLUSTRATIONS

<u>Figure</u>	<u>Title</u>	<u>Page</u>
1	Advanced Tape-Laying Head	12
2	Wing Rib	14
3	Flintston Machine	17
4	Titanium Multi-Step Splice Cross-sections	19
5	F-14 Boron Stabilizer	20
6	Typical Autoclave Setup	24
7	Combination Drilling-Countersinking Tools	30
8	First Failure Distributions	34
9	Cumulative Frequency	45
10	Frequency Groups	45
11	Local Coordinates	68

LIST OF SYMBOLS

<u>Symbol</u>	<u>Description</u>
α	Thermal coefficient of expansion; Shape parameter
a, b	Ellipse semi-major, minor axes
A, k	Constants
β	Scale parameter; Material compliance
CV	Coefficient of Variation
f	Distribution function
Γ	Gamma function
μ	Material characteristics
Φ	Stress function
ϕ	Angle
p	Pressure; material constant
q	Material constant
R	Reliability function
σ	Square root of the variance; Stress
S	Arc length
τ	Shear stress
T_x, T_y	Tractions
θ	Angle
u	x-displacement
v	y-displacement
x	Distribution variable; coordinate
\bar{x}	Mean value
y	Coordinate
z_k	Material Coordinates
ξ_k	Elliptical Coordinate

CHAPTER I
REVIEW OF THE INTERACTIVE PROGRAM

1.1 Introduction

This final report is divided into three parts: Volume I reviews some aspects of the Interactive Program during the contract period; Volumes II and III are Ph.D. theses written during the course of the current and preceding contract period [1].* The following chapters in this volume consist of *selected* student reports from various project activities.

The Interactive Program has been a successful program of coupling faculty and students at Carnegie-Mellon University (CMU), The Air Force Materials Laboratory, and industry, most notably General Dynamics Corporation, Convair Aerospace Division, Fort Worth. The program has focused on the application of mechanics capabilities at CMU to the stress and strength analysis of advanced composite structures. The broad objectives of the program have been the following:

1. Creation of effective means of communication between CMU and industry;
 2. Involvement of the CMU team of students and faculty in the definition and solution of fundamental problems arising from the application of advanced composites in aerospace structures;
- and

*References are denoted by brackets and are located at the end of each volume.

3. Development by the CMU team of new analysis capabilities and results, strength criteria, design methods, and educational material for advanced composites technology.

Two elements were keys to the success of the CMU program. The first was the development of an educational basis for the student project activities. Due to the relatively new nature of composites technology, this was accomplished as an early part of the preceding contract. The basic outline of the educational material and the description of the program organization and timing are reviewed in [1].

The second element for success was the development of a record of success and expertise, coupled with a level of external visibility sufficient to give credibility to the CMU team. The major contribution for this success has been the use of a major portion (20-25%) of the program budget for travel. These trips generally involved the students and/or the principal investigator travelling *to industry*. By making frequent visits to industry and program review meetings it was possible to develop contacts, credibility and visibility necessary to the program's success. Further aspects of the program visibility are described below.

The CMU-developed philosophy also contributed materially to the success of the program. It was initially decided to concentrate on problems which had a clear engineering significance as opposed to more "academic" pursuits. Thus, initially at least post graduate students were not wedded to a particular research program. Further, it was decided to maintain, to the extent possible, a framework of project

activities closely attuned to current CMU faculty capabilities. These included fracture mechanics and elastic stress analysis. Ample project problems were found that were based in these areas but which had immediate pay-off potential for industry.

The two most significant derivatives of this philosophy are attached as separate volumes of this report, both of which are Ph.D. theses written as a result of projects started four years ago. The first develops an efficient synthesis procedure for mechanical joints in composites; the second concerns a macromechanics basis for an engineering fracture mechanics of advanced composites.

1.2 Research Results of the Program

As noted above, the CMU team undertook a number of projects in the general area of strength analysis of advanced composites. The approach used was to retain the simple basis of two dimensional elasticity and elastic fracture mechanics. Several papers [2-6] were published during the contract to provide visibility for the CMU efforts. While much of this work retains a speculative flavor, particularly on the question of fracture criterion, it has received some positive response from industry. As an example, General Dynamics engineers have made use of fracture mechanics methodology to define a fail-safe composite panel.

The research results have been described in several technical formats. During the current report period papers [2,6,7] were presented at AIAA/ASME Structures, Structural Dynamics, and Materials

conferences in 1971, 1972, and 1973. One paper [3] was presented at the 1972 ASTM meeting on Analysis of Test Methods for Advanced Fibers and Their Composites. These research results were also discussed at numerous Air Force review meetings and technical committee meetings.

In October 1972 Drs. Cruse, Swedlow, and Halpin organized the first Colloquium on Structural Reliability [9], under partial support of the Air Force Office of Scientific Research. This meeting brought together experts in composites, fracture mechanics, statistics, and structural reliability for three days of valuable technical interaction. This meeting was held at Carnegie-Mellon University. Currently about 120 copies of the *Proceedings* [9] are in circulation.

1.3 Conclusions

It is not entirely possible to define the success of the Interactive Program in Quantitative terms. However it was clearly shown that it is possible to create valuable interaction between the university and industry environments, around a well defined project area.

Further, the program has contributed to the technical knowledge in the area of strength of advanced composite materials. This has been accomplished through the technical literature as well as through various technical meetings. The fact that certain people pick us out to disagree with is indicative of some degree of success.

Finally, the program has seen to members of the CMU team placed in the technical community concerned with composites. Dr. H. J. Konish, Jr. is a post-doctoral fellow at the Air Force Materials Laboratory. Dr. J. P. Waszczak has taken a position with General Dynamics in San Diego, California. The fact that both individuals received several offers attests to the success of the engineering emphasis of the Interactive Program.

CHAPTER II

FABRICATION PRACTICES AND PROBLEMS FOR BORON AND GRAPHITE EPOXY

2.1 Introduction

Advanced composite materials, particularly boron and graphite epoxy have reached the stage in their development where the possibilities and problems associated with fabrication of components from these materials are being fully investigated. Now that the materials have reached a satisfactory level of design reliability, the time has come to determine whether structures can be manufactured from boron or graphite fiber composites for reasonable costs. The key to the widespread acceptance of these new materials is going to be whether the additional performance gained by using them is worth the additional and sometimes unique problems of their fabrication. This report examines the major areas of advanced composite fabrication pointing out some of the current techniques employed by those in the "industry". The major problems in each area are outlined as well as advances by individual companies in some particular aspect of that area.

2.2 Tooling

The most important parameter in the choice of a tooling material is the coefficient of thermal expansion (α). The value of α for the tool should be as close as possible to the coefficient of thermal expansion for the material that is to be cured on the tool for a number of reasons. First of all, an improper match of these coefficients could cause the curing material to separate from the tool surface and therefore not cure with the proper contour. Secondly, the curing process involves the bleeding of resin from the part and the tool often includes dams along the perimeter of the piece to prevent excessive resin flow. If the tool has a higher value of α than the part, the dams may separate from the perimeter and allow too much resin to flow from the matrix. If the value of α is too low in the tool, the part will try to expand more than the dams will permit, causing the part to buckle. Finally, a high coefficient of thermal expansion may cause the tool to fail due to fatigue caused by thermal stresses in high-volume production.

The use of conventional tooling methods and materials has thus far proven to be adequate in the manufacture of advanced composite structures. Mild steel designated M-2, is one of the more popular materials since it is relatively inexpensive and has

a value of α reasonably close to that of boron epoxy. However, most of the fabrication of composites thus far has been done with relatively smooth, flat surfaces. It is possible that the manufacture of components with a high degree of curvature or a number of complex contours may require tools with an almost perfect thermal match.

At least two companies have undertaken programs toward this end. Boeing/Seattle (B/S) is currently evaluating the use of a ceramic castable compound which they have named Comptite II. The exact composition of Comptite II is Boeing proprietary information but it is basically composed of a betaeucryptite and a fused silica binder. By varying the percentages of betaeucryptite, it is possible to vary the coefficient of thermal expansion of the material. In this way, α for Comptite II can be best matched to α for boron or graphite epoxy. B/S reports that an exact correlation of α 's may cause distortion and that the tool works best when its coefficient of thermal expansion is slightly higher than that of the boron or graphite epoxy which is being cured. Comptite II is easy to form and demonstrates high fatigue life.

Another major exception to steel tooling was performed by General Dynamics Convair Division in Fort Worth (GD). In the prototype manufacture of a graphite epoxy F-5 fuselage component, GD used a female graphite epoxy tool to exactly match coefficients

of thermal expansion. Although tool costs were estimated at two-thirds the cost of a comparable steel tool, metal would be used in a high-volume production run because it is believed that steel could withstand more cycles in the autoclave.

2.3 Lay-Up

The crux of any fabrication technique is the method by which the raw material is transformed into a final shape. In the area of composite structures, this stage of operation is termed lay-up since a component is formed by the successive buildup of layers of raw material.

2.3.1 Description of Material

Boron and graphite epoxy come in two basic modes: 3-inch tape on spools, by far the more common of the two, or "wide goods" which vary in size and shape. The boron or graphite fibers are all oriented in a single direction in the resin matrix and it is the varying angles of orientation of the layers which gives the material its desirable strength characteristics after curing.

Boron and graphite epoxy have shelf-life limitations which are highly dependent on temperature. Most manufacturers specify a 3-month shelf-life for tape stored at 0°F or lower. Once the boron or graphite reaches room temperature, about 70°F, it should be used within the next 10 days. These rather specific time-temperature requirements necessitate the careful management of inventories and lay-up procedures to ensure that the tape retains its mechanical properties. Some alternative methods for laying-up composite structures from 3-inch tape are described below.

2.3.2 General Dynamics Method

2.3.2.1 Automated Machine Lay-Up

GD has practical experience in manufacturing pieces with an automated tape-laying machine. The F-111 horizontal tail was done on a computer programmed basis using Narmco 5505 boron epoxy. The machine is preset to lay the tape to the specified tolerances one layer at a time. The head is rotated for the correct orientation of each layer and the machine proceeds to lay tape on tape until the component is built up to the correct number of layers. A typical tape-laying machine head is shown in Figure 1. Incorporated in some models is a light-sensitive inspection device which detects broken and crossed fibers or excessive gaps between the fibers in the 3" tape. This section of tape is automatically rejected and the machine does not lay any tape until the section passing through the detector again meets the standards. This type of machine is highly sophisticated and most of the work done by it has been purely experimental rather than actual production. GD believes that the tape laying machine can have a valuable application if it is used to manufacture many parts in a single operation. For example, GD has plans to manufacture the wing rib shown in Figure 2 in the following manner:

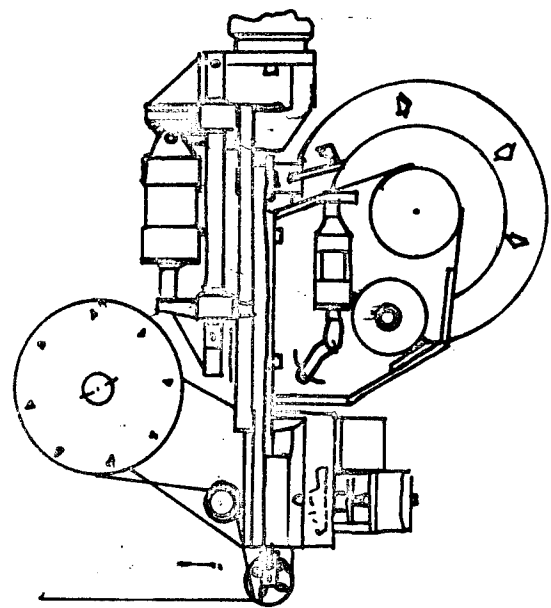

SIDE VIEW

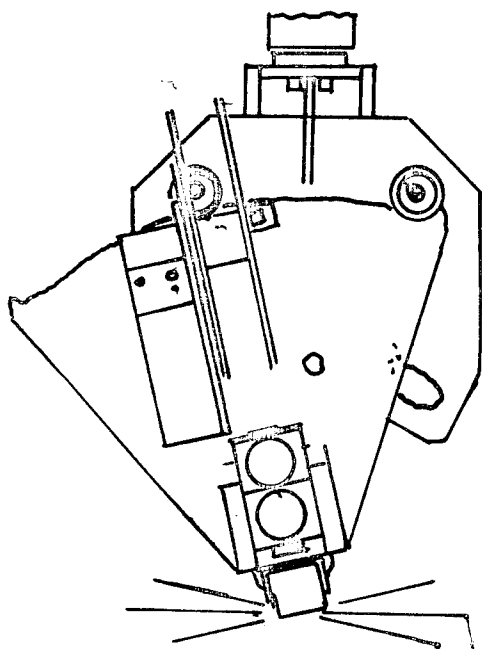
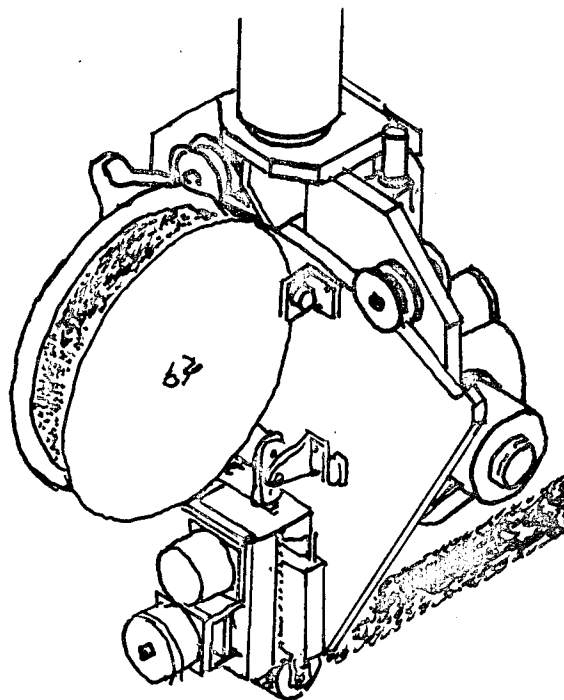

FRONT VIEW

Figure 1. ADVANCED TAPE-LAYING HEAD

Skin

1. Lay-up a solid laminate 30' x 10' and cure using the vacuum bag process.
2. Cut the large laminate into multiple panels of the correct size.

(Note): The 30' x 10' laminate may be cut before or after curing depending on the availability of composite machining equipment.

Hat Stiffeners

1. Fabricate graphite flat sheet stock and trim to the required length and width.
2. Roll form each strip to a hat shape.
3. Locate the uncured hat sections over a rubber mandrel.
4. Locate the rubber mandrels on the pre-cured solid laminate pieces and cure in place.
5. Remove the rubber mandrels.

The concept of deriving many parts from a single master does not end with this rather simple application. GD looks forward to manufacturing wing skins in almost the same manner. The tape-laying machine can be programmed to have the head discharge tape only at specified intervals, and at the proper orientation. In this way,

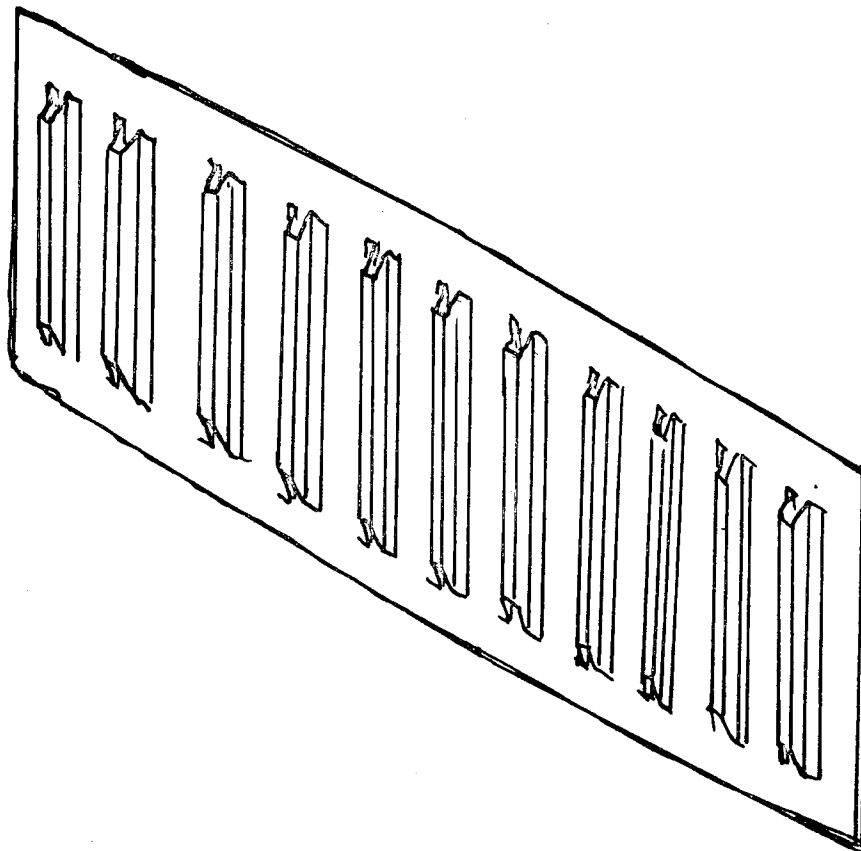
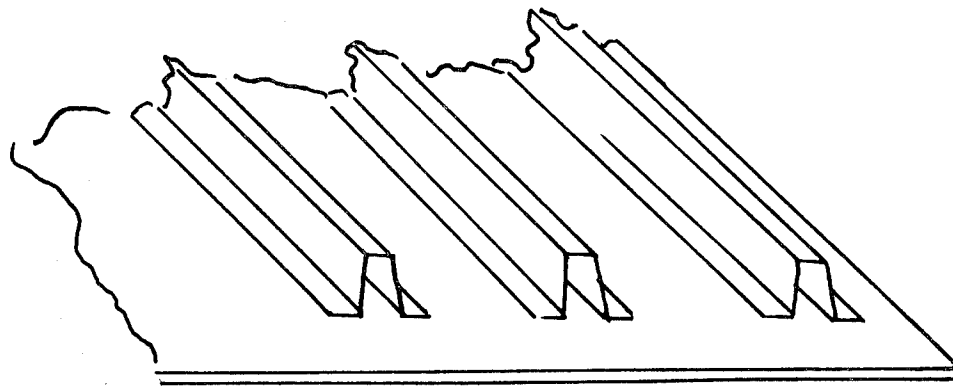

Figure 2. WING RIB

complex reinforcing areas can be built up on a flat skin and then covered with the outer layers. A cutting device similar to a cookie cutter would then stamp out a number of fabricated skins from the master lay-up. As stated previously, this concept has not been used in production as yet since it is predicated on the availability of effective composite cutting tools.

The automated tape laying machine itself is far from perfected, however, and its real value as a production instrument will only be realized after some critical problems are solved. The light-sensitive defect detecting apparatus is highly sophisticated and doubts have been raised as to its effectiveness in spotting a defect and rejecting the tape when the machine is operating rapidly. The variations from supplier to supplier in the tape itself make it difficult to design a head capable of accepting every brand of tape available. The amount of computer programming necessary to insure that the head lays the correct length of tape at the proper orientation within specified tolerances is a factor that will have to be reckoned with. Finally, despite the fact that advanced tape laying heads can now move on five axes, there is still some question as to their ability to lay up pieces with a high degree of curvature or complex contours.

2.3.2.2 *Hand Lay-Up*

Because of the above problems, GD does the vast majority of its tape laying by hand. The material, in the form of 3" tape, is inspected for broken and crossed fibers and gaps between the fibers before it is used. The tape is laid up on a metal tool with each layer at the proper orientation. Each strip of tape in the same layer must be within 0.03" of the adjoining strips and overlapping is not permitted. This is a more tedious process than using a machine but quality control is better and complex curves can be laid up. Most of GD's work has been experimental, such as the F-5 fuselage and some fuselage bulkheads, but F-111 doublers have been made in some quantity using this process.

2.3.2 *Grumman Aerospace Method*

The only actual "on-line" production of composite aircraft components is being done by Grumman Aerospace of Bethpage, N. Y. (GA). Under contract from the Navy, they are producing skins for the F14-A horizontal stabilizer from boron epoxy tape. GA terms the operation semi-automated because, although the work is done by hand, the tape lay-up is performed on a device which they developed and call the "flintstone machine" (Figure 3). Unlike the technique used at GD where a bottom layer is placed on a tool or form and subsequent

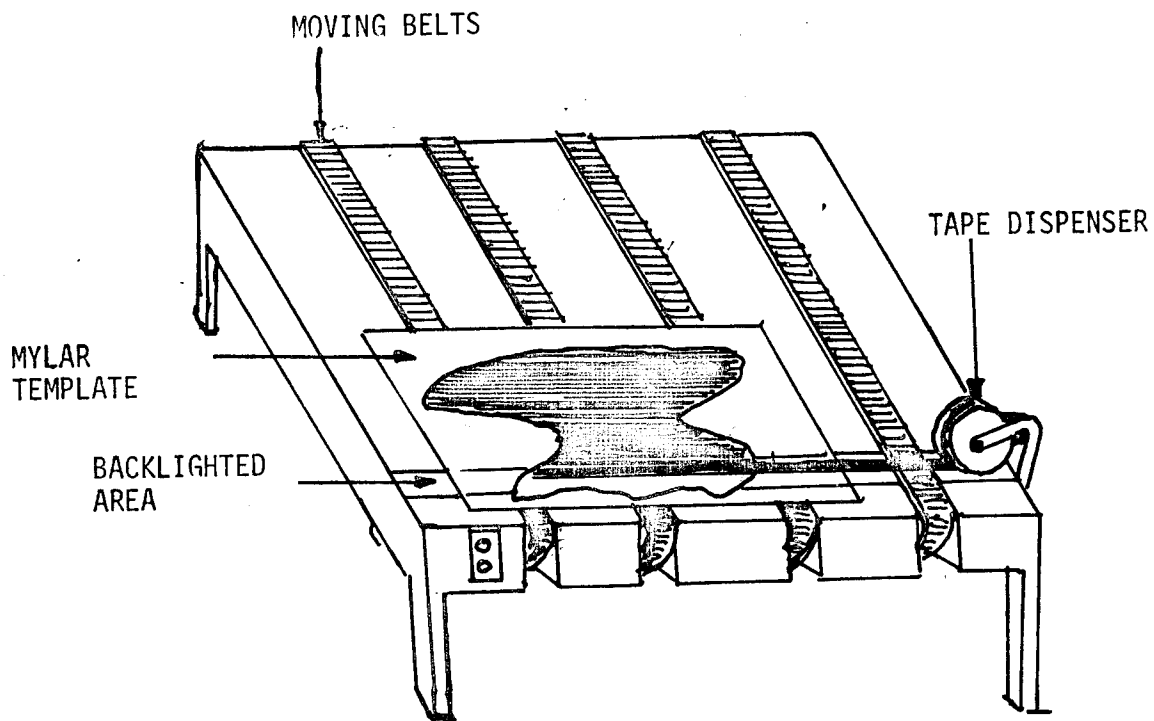

Figure 3. FLINTSTONE MACHINE

layers are built-up one atop the other, Grumman uses the flintstone machine to lay-up each individual layer separately. The outline of each layer and its orientation is determined by a computer analysis of the loads in the stabilizer. This outline is permanently traced on a mylar template and oriented to match the proper orientation of the tape for that layer. For example, if a layer of 45° was specified the outline of that layer would be rotated 45° on the mylar template.

The template is fastened to the flintstone machine and the operator moves the belts so that the mylar is in a position to receive the first strip of tape. The composite tape is unwound from a reel by hand and placed on the template over a portion of the table that is backlighted. Here, the operator can easily inspect the tape for broken and crossed fibers and gaps between the fibers. If the section of tape is defective, it is discarded and another section unwound into place. If the tape is good, it is pressed onto the mylar template and trimmed at the edges to exactly fit the outline. The operator then presses a button and the machine moves the template exactly three inches so that the next section of tape can be laid up within 0.03" of the previous one. This operation continues until the entire outline on the template is laid up with tape. The mylar template is removed, the layer of tape covered with plastic to protect it, and the next template placed on the flintstone machine. When all the layers of a respective skin have been laid up, the skin itself is then built up on a metal tool. The mylar template has a series of holes which fit over pegs on the tool to insure that each layer has the correct orientation. When complete, the tape is pressed into the layer below it and the mylar peeled back. The entire skin is bagged and sent to the autoclave to cure.

The end product is indistinguishable from one that is laid up a strip at a time, but Grumman claims two significant advantages using

their method. First, the flintstone machine lends itself more readily to rapid production since it is semi-automated and a number of them can be used at once to lay up different layers of the same skin. Second, the backlighting on the area where the tape is to be laid gives visual inspection of every piece of tape in the skin thus providing a high degree of quality control. Presently, Grumman is manufacturing eight skins per month and they hope to double that figure by the end of 1972.

The boron skins cover an aluminum honeycomb which decreases in density moving out toward the edges. Boron is mounted on the structure by titanium fingers shown in Figure 4. In this way, all drilling can be done through the titanium rather than encountering the difficulties of cutting boron. The entire stabilizer structure is outlined in Figure 5.

Fig. 4: Titanium multi-step splice cross-sections

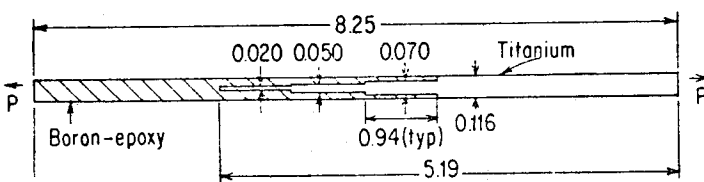

Fig. 4A: Edge splice (dimensions in inches).

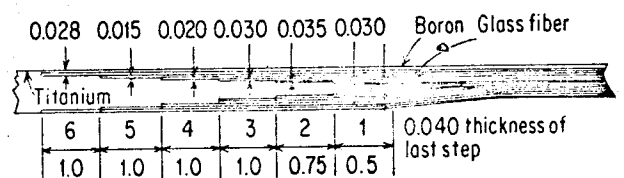

Fig. 4B: Main splice. Adhesive is Metlbond 329.

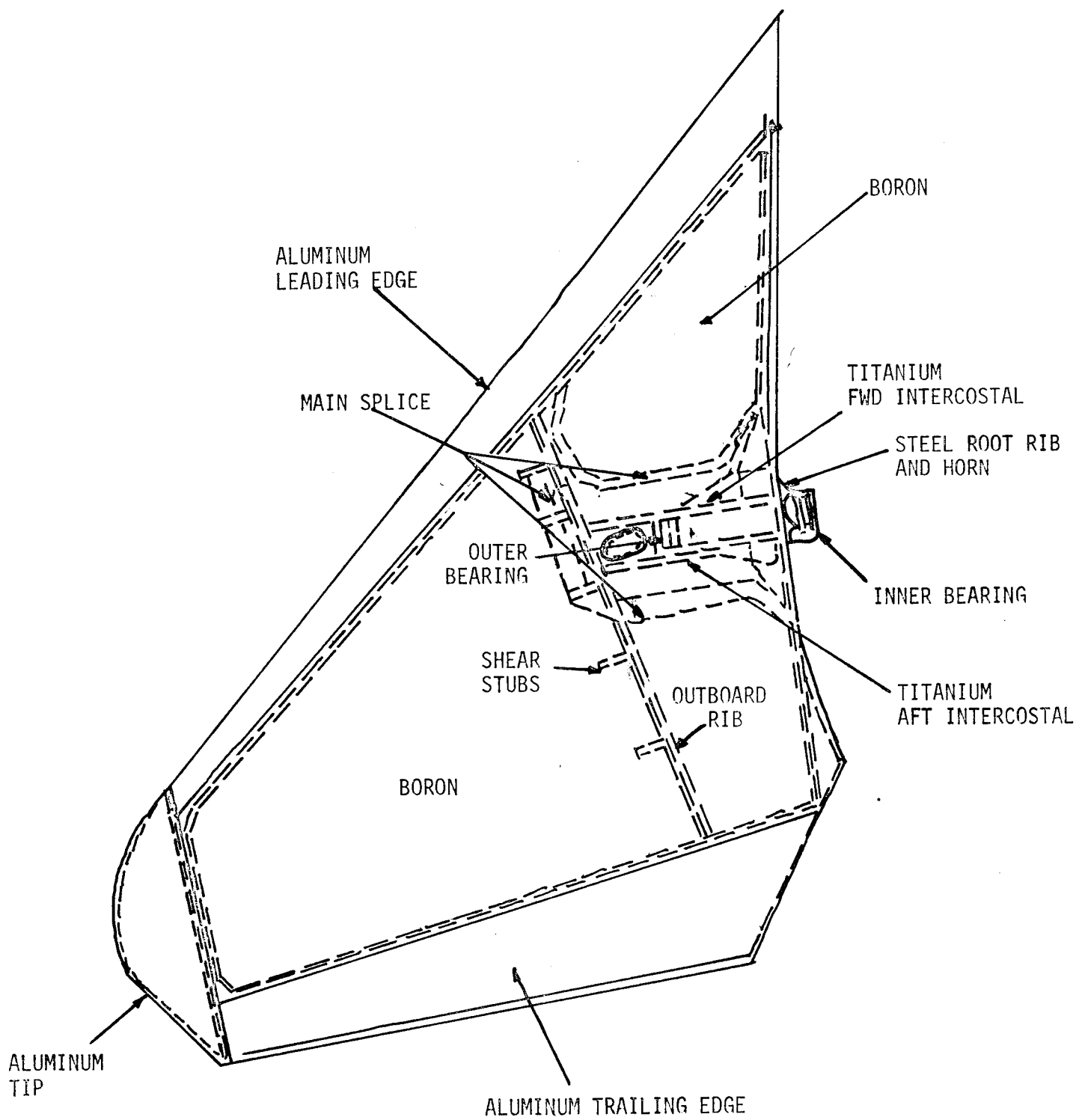

Figure 5. F-14 BORON STABILIZER

2.3.4 *Problems of Mass Production*

Despite Grumman's apparent success in fabricating the F-14 stabilizer skins, there are some problems which must be overcome before composites can be used on a mass production scale. Probably the greatest single impediment to successful fabrication with composite materials is the present lack of design/manufacturing coordination. The people working on advanced ideas which incorporate graphite or boron epoxy must communicate with those involved in manufacturing to a greater degree. The most efficient and promising design is worth nothing if the structure cannot be made in the shop or carries a prohibitive price tag. An understanding of the special problems involved in the fabrication of composite parts will help designers direct their efforts toward a component that is easily producible. The design/fabrication interface must be fully developed before the mass production of composite structures is economically feasible.

It is possible that many of the composite parts manufactured presently are "overdesigned". The use of a computer to determine the optimum size and orientation of each layer in a piece is often expensive and results in a complex pattern that is difficult to assemble and insure by quality control. The use of less complicated orientations of layers may result in a part that suffers only a

small performance penalty and is much more cost effective.

One of the largest hardware problems faced by manufacturers is the inconsistency in the amount of tack on the tape surfaces, even in batches from the same supplier. Insufficient tack on the surface may cause the layers to separate and produce gaps in the component. Quality assurance is lowered and sophisticated testing devices are necessary to determine the location and extent of these gaps. On the other hand, excessive tack makes the tape difficult to handle while laying up by hand and the quality of the component may be impaired by the presence of overlaps and broken sections of tape.

2.3.5 Alternate Manufacturing Approaches

The entire concept of lay-up is predicated in the industry selection of 3" tape and wide goods as the form of the raw material. This arrangement may be necessary to fully utilize the performance benefits that accrue from a structure of many unidirectional layers, each very strong in its respective direction. But for components in which the strength/weight ratio is not so critical, the use of a resin matrix impregnated with randomly oriented, short graphite or boron fibers should be investigated. It is quite possible that some of the current manufacturing techniques employed by the fiberglass

industry could be successfully applied to composite technology. The most promising appears to be the sheet molding compound process (SMC) which is used to manufacture automobile parts and panels such as the Corvette body. The raw material is made by chopping long strands of glass fiber as they are pulled over the resin matrix so that they drop onto the resin in a random manner. The compound is rolled onto drums and ready to be used. Although there are no time-temperature requirements such as those mentioned on page 5 with fiberglass in this form, it is not clear whether boron or graphite would also be relieved of this problem. Parts are fabricated from SMC simply by unrolling the desired length, placing it on a mold, and curing it by compression. Rapid production of parts on a large scale using this method is economically practical as evidenced by the number of fiberglass firms using it. Even if a structure made from boron or graphite in this form could not meet performance criteria, SMC could still prove to be a feasible method for utilizing scrap to fabricate pieces which are not critical in carrying loads. From a fabrication point-of-view, an investigation is necessary to study the economic implications of continuing to manufacture boron or graphite parts from 3" tape.

2.4 Curing Process

Once the part is laid up it is sent to the autoclave to cure. Curing permits the resin to redistribute around the boron or graphite fibers so that the part is an integrated whole rather than a number of layers stuck together. A typical autoclave setup is shown in Figure 6.

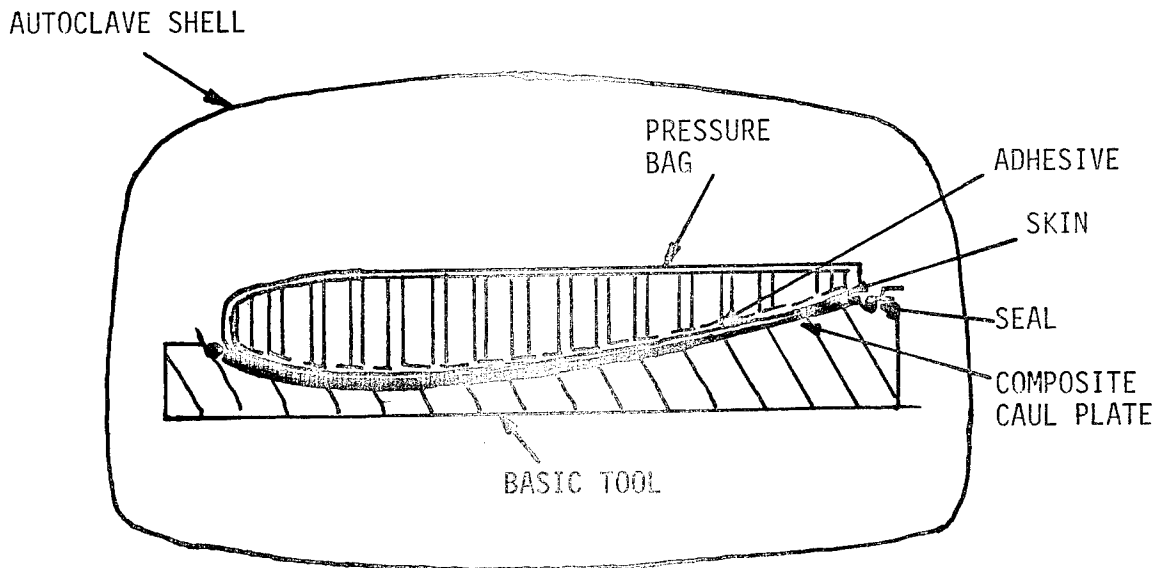

Figure 6. TYPICAL AUTOCLAVE SETUP

The part is not placed directly on a metal tool but rather on a layered bleeder system which separates the two. The bleeder system completely encloses the composite part to be cured and is necessary to remove the excess resin which flows from the piece at elevated temperatures. A typical bleeder system consists of the following materials starting at the part surface:

1. A layer of TX1040 separator to prevent the bleeder cloth from sticking to the part.
2. Layers (depending on the part thickness) of paper bleeder or 120 dry glass to absorb the excess resin.
3. A layer of mylar film with perforations at specified intervals.
4. A layer of ply paper vent cloth to measure the amount of resin coming through the mylar film. This is a check to determine if the part is being bled correctly.
5. A plastic pressure bag to cover the entire composite part.

One of a number of different cure cycles is followed depending on the type of material used. For example, the basic cure cycle for Narmco 5505 specifies 2 hours in the autoclave at 85 psi and 350°F. However, minor changes are frequently made to compensate for part thickness, resin flow, and few other small details.

There are a number of problems involved in the curing process which are presently being examined. The most significant hardware problem is the volume content and type of resin used in the matrix. An incorrect estimate of the resin volume or chemical composition can cause serious problems in bleeding during cure. The resin may flow too quickly, too slowly, unevenly, or possibly not at all, all of which can cause the part to be defective.

One problem in the cure cycle that would probably not be readily foreseeable is the tedious task involved in placing and removing the plastic vacuum bag over the part. Placing the tape around the edges is time-consuming in itself, but removal of the tape and bag after curing has taken place is even more difficult. Toward eliminating this problem, Grumman is doing development work on improved advanced composites bag molding processes. They have developed a silicone blanket with a vacuum actuated O-ring to hold the blanket to the part. Work is not complete on the project but the major advantages that appear feasible using the silicone blankets are reduced lay-up and removal time, re-usable bagging, and applicability to complex shapes. Successful development of such a process would be a significant step toward the fabrication of composite parts on a mass-production scale.

The greatest expense involved in the curing process is the time required for the cure cycles while the part is in the autoclave. Grumman is currently conducting a test program using microwaves at the frequency of FM broadcasting (~100 MHz); this could cut cure time and autoclave expense tremendously. Tests have been performed on fiberglass reinforced resins with satisfactory cure being achieved in less than half an hour. When this cure time is compared to those involved with heat-treating processes the time saved can be measured in *hours*. Grumman is presently seeking additional funding from the Air Force Materials Lab to run a full scale testing program on boron and graphite impregnated resins. It is quite obvious that if boron or graphite epoxy can be cured using microwave techniques, the cost of the finished component could be significantly reduced.

2.5 Machining Problems

A serious drawback associated with the use of advanced composites is the difficulty involved in machining the finished product. Parts are usually laid up to perfectly specified dimensions so that trimming of the composite material itself is not necessary.

However, there are locations where bolt holes and other mounting points must be drilled. Because of the hardness of the fibers in advanced boron composites, conventional drilling and machining methods deliver only minimal results. Diamond-tipped drills have shown some degree of success but these tend to wear out relatively quickly.

Some manufacturers have taken steps in the fabrication process to eliminate the necessity of drilling a composite skin. Grumman uses the stepped titanium fingers shown in Figure 4 to attach the boron skin to the stabilizer substructure because mounting points can be drilled more easily in the titanium. There has been discussion about the prospect of laying up the composite around plugs which will be removed after cure to provide the proper holes. The possibility also exists that the plugs will be metal which can be drilled out after cure to provide mounting points similar to the titanium finger concept utilized by Grumman.

The real breakthrough in advanced composite machining, however, appears to be in the area of ultrasonic drilling. Funded by the Air Force, Grumman is currently experimenting with ultrasonic techniques on boron/epoxy. Thus far, the results have shown excellent potential for the use of ultrasonic equipment to significantly reduce the time and difficulty involved in drilling advanced composites. A special diamond-studded drilling bit has demonstrated good endurance when used with ultrasonic assistance. Since most of the structures being fabricated are composite skin and honeycomb metal core it is of particular importance that drill bits which work well on metal are poor for advanced composites and vice versa. When drilling a simple hole through such a structure, the metal-favoring bit is used and the penalty incurred on the thin skins is accepted. However, if a countersunk hole is necessary, using only one type of drill bit is unacceptable. To alleviate this problem, Grumman has developed the two-stage drill bit shown in Figure 7. The neck is a metal-favoring composition which is hindered as it drills initially through the composite skin but becomes very effective in the metal core. The tapered base is a composite-favoring composition which allows the countersink to be drilled in the skin in one operation. This combination drill bit coupled with ultrasonic assistance promises to significantly reduce some of the machining time involved in the fabrication process.

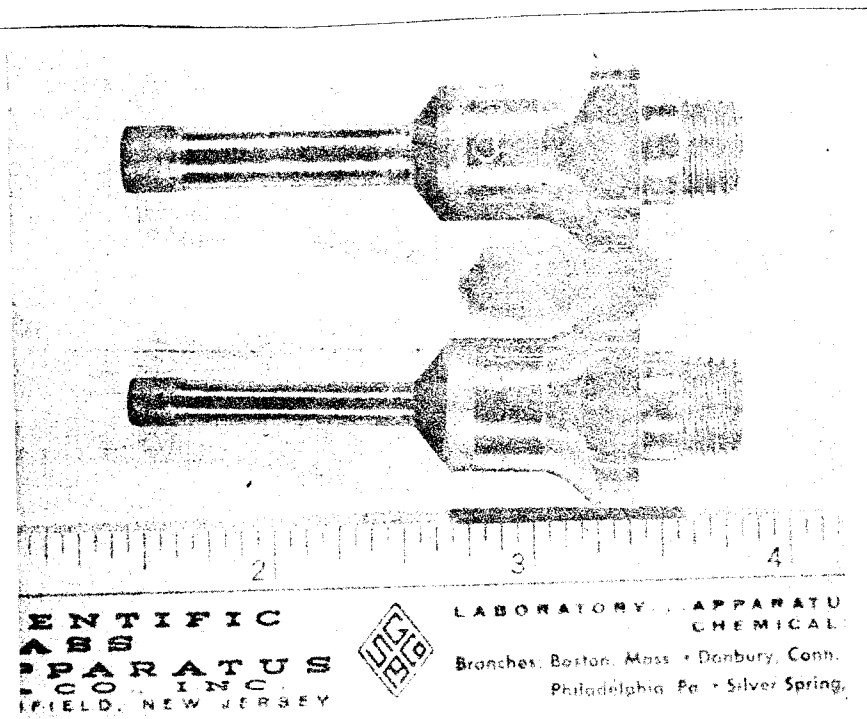

Figure 7. COMBINATION DRILLING - COUNTERSINKING TOOLS

2.6 Conclusions

The Air Force and all the various advanced composite manufacturers have invested a tremendous amount of time and money in amassing the current store of knowledge on composite materials. The fact that they are now becoming concerned with the direct problems of fabrication demonstrates that the materials are no longer considered just an experimental venture. Prior work and investigation have developed a confidence in composite materials as an effective substitute for conventional metals in aircraft construction. The focus has now been placed on the practicality of advanced composites on a cost basis rather than a performance or reliability one. There are many problems, some of them mentioned in the report, which remain unsolved in the realm of composite fabrication. But the fact that companies are addressing their efforts toward new tooling materials, automated fabrication techniques, and sophisticated yet cost effective practices in curing and machining, clearly demonstrates that advanced composite materials have a tremendous potential in the immediate future.

CHAPTER III

A COMPUTER PROGRAM FOR WEIBULL STATISTICS

3.1 Review of Weibull Statistics

The following report outlines the basic equations of Weibull statistics and presents a computer program developed in order to fit empirical data to the extreme value (Weibull) distribution. The computer program takes unsorted numerical data and performs all of the standard sorting and cataloging routines necessary for statistical analysis. The data is then fit in a least square sense to a Weibull distribution function and a chi-square confidence test is employed.

The basis for a fatigue life prediction includes statistical inference from an empirical data base, and theoretical or engineering reasoning to choose a probability model. It is now recognized that the extreme value (Weibull) distribution is the best physical/theoretical model for the fatigue process. Generally speaking, the shape parameter (scatter) may be established by component testing and the scale parameter (roughly, the mean) may be established by a few (1-3) full scale tests.

The analytical reliability (or 1-cumulative distribution) cumulative function for the Weibull distribution is given by

$$R(x) = \exp - [(x/\beta)^\alpha] \quad (1)$$

where α is the shape parameter and β is the scale parameter. The

mean value for any distribution density function $f(x)$ is given by

$$\bar{x} = \int_{-\infty}^{\infty} xf(x)dx \quad (2)$$

and the variance, by

$$\begin{aligned} \sigma^2 &= \int_{-\infty}^{\infty} (x-\bar{x})^2 f(x)dx \\ &= \int_{-\infty}^{\infty} x^2 f(x)dx - \bar{x} \end{aligned} \quad (3)$$

For the Weibull distribution (1), the mean is given by

$$\bar{x} = \beta[\Gamma(1 + 1/\alpha)] \quad (4)$$

and the variance is given by

$$\sigma^2 = \beta^2[\Gamma(1 + 2/\alpha) - \Gamma^2(1 + 1/\alpha)] \quad (5)$$

In general, the coefficient of variation is σ/\bar{x} such that for (1)

$$cv = \sigma/\bar{x} = \sqrt{[\Gamma(1 + 2/\alpha) - \Gamma^2(1 + 1/\alpha)]} / \Gamma(1 + 1/\alpha) \quad (6)$$

In treating experimental results one chooses plotting position reliability (e.g. see Freudenthal [10] Gumbel [11]). For the m^{th} ordered data point in a sample of size- n , the empirical reliability is given

$$R(m) = 1 - m / (n + 1) \quad (7)$$

The median for (7) is found by plotting $R(m)$ vs. x_m and taking the

intercept at $R = 0.5$. The variance from the empirical data is computed from the mean (average)

$$\sigma^2 = \frac{1}{n+1} \left[\sum_{i=1}^n x_i^2 - \frac{1}{n} \left(\sum_{i=1}^n x_i \right)^2 \right] \quad (8)$$

The median time to first failure is denoted \bar{x} , in (1), and in a finite sample by $m = 1$ in (7) such that

$$\exp - [(\bar{x}_1/\beta)^\alpha] = 1 - 1 / (n + 1) \quad (9)$$

which can be solved for \bar{x}_1

$$\bar{x}_1 = \beta [-\ln(1 - \frac{1}{n+1})]^{1/\alpha} \quad (10)$$

It has been found from extreme value statistics that the distribution of first failures in samples of equal size- n is the same as the parent population; i.e. the same functional form and the same α . This is illustrated for the normal distribution in Figure 8.

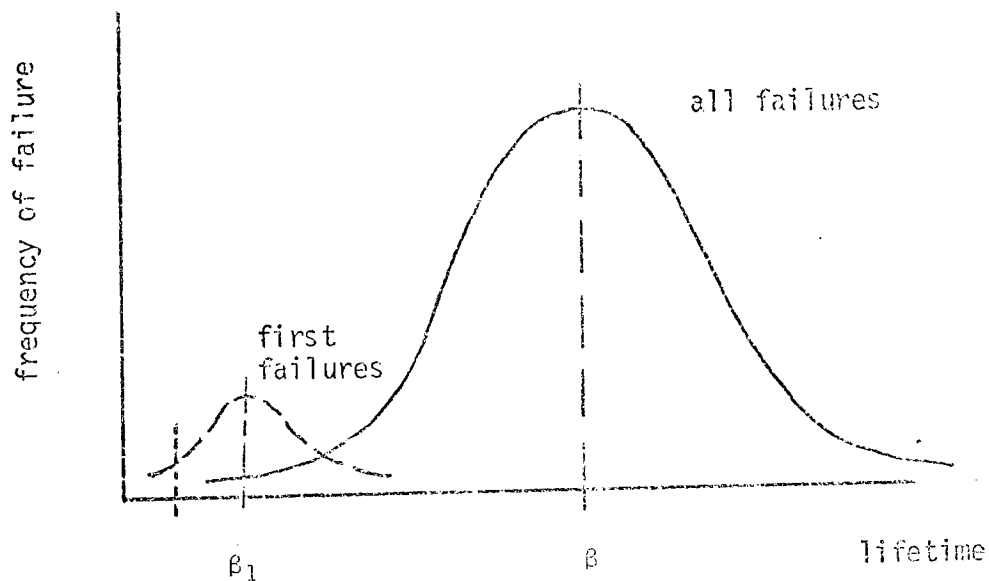

Figure 8: First Failure Distributions

The scale and shape parameters for the first failure distribution are given by

$$\beta_1 = \beta n^{-1/\alpha} ; \alpha_1 = \alpha \quad (11)$$

The frequency density function for first failures in samples of size-n is given by

$$f_1(x) = n f(x) \exp \left[- \left(\frac{n-1}{n} \right) \left(\frac{x_1}{\beta_1} \right)^\alpha \right] \quad (12)$$

Eq. (12) can be derived on the following basis. Let $R(x)$ be the probability of survival, i.e. $1-F(x)$, of a single item. The probability of survival of n-items is $[R(x)]^n$, which is the probability of no failures in n-items. The probability of failure of one out of n-items is then

$$F_1(x) = 1 - [1 - F(x)]^n \quad (13)$$

from which the probability density function is obtained

$$f_1(x) = n(1 - F(x))^{n-1} f(x) \quad (14)$$

Eq. (14) for the Weibull density gives (12).

The following sections outline the operation of the computer program as well as the numerical and mathematical foundations for each section. The computer program listing in a sample problem output are included.

3.2 Detailed Program Description

3.2.1 *Array Dimensions*

All arrays are given a dimension of 100. This is arbitrary, and can be changed by altering cards (1)*, (2), and (3). In general, the following rules must hold pertaining to array dimensions. The following arrays must have dimension greater than or equal to the number of data points: X, Z, F, F1, F11, and P. The arrays B1, B2, VM, T, and T1 must have dimension greater than or equal to the number of groups designated.

3.2.2 *Data Points, Group Numbers* (1) [12]

The number of data points is input. This includes the total number of data values, even though two or more values may be the same. The data values may be input in any convenient order. The number of groups is selected for the purpose of setting up a histogram. That is, any convenient number of groups may be chosen. In general, to make a histogram meaningful a large number of data points is necessary. The number of groups would increase with the number of data points with a maximum of perhaps ten. The correlation between number of groups and number of data points is quite arbitrary.

*Parentheses refer to program operation sequence numbers as listed in Section 3.4.

The input formats for N (number of data points) and N2 (number of groups) are identical. They consist of printing three digits on the first 3 positions on two cards. Both must be right justified and are integers. No decimal point is necessary.

Data values are input as real numbers. They are also right justified with decimal points. Each value is allotted ten positions for digits and decimal point. A maximum of five values is allowed on each card.

The selected critical chi-square value (generally used for comparison with the calculated value and designated by CHCRIT) and its associated confidence level (SIGLEV) are input identically. They are on two separate cards, real numbers, and are right justified with decimal points. The first ten spaces on these two cards are allotted for these values. The CHCRIT value and its associated SIGLEV are chosen with reference to the number of data points. For N equal to the number of data points, N-1 is equal to the number of degrees of freedom of the test group. Generally tables of values of N-1 vs. SIGLEV result in values of CHCRIT. These tables are found in many mathematical reference books.

In summary, input values follow the following form:

CARD	INPUT	FORM
Card 1	No. of data values (N)	(I3)
Card 2	No. of groups (N2)	(I3)
Cards 3+	data values (X(I))	5F10.0
Card 4+	selected crit χ^2 (CHCRIT)	F10.0
Card 5+	selected conf lev (SIGLEV)	F10.0

In the case of N and N2, the maximum value inputted is 999. To increase this, the format must be changed.

For all input parameters with formats of F10.0, the maximum input value is 999,999,999. To increase this, the format must be changed. Data values are represented in the array X.

3.2.3 *Sorting of Data Values*

The data values are ranked in ascending order, i.e. $X(1)$ = smallest value, $X(N)$ = largest value. This is done to simplify operations carried out later which require differentiation of the relative magnitude of the values. Cumulative frequency evaluation, for example, requires that its value ($F(1)$) grows as the data value grows.

The method of sorting is known as a 'bubble sort' where the following procedure is used. The first two data values are compared and the largest chosen. It is then compared to the next value and the largest of those two is chosen. It is then compared to the third, etc. Finally the largest value remains. The procedure is repeated for $I = 1$ through $N-1$ values this time. The remaining value will now be the second largest. The procedure is repeated until all values are ranked.

3.2.4 Calculation of Cumulative Frequency (4) [13]

The cumulative frequency value for each data point is calculated. For the present study the Weibull distribution will be used to describe both the frequency density and cumulative frequency functions, as given by

cumulative frequency

$$F(x) = 1 - e^{-\left(\frac{x}{\beta}\right)^\alpha} \quad (15)$$

frequency density

$$f(x) = \frac{dF(x)}{dx} = \frac{\alpha}{\beta^\alpha} x^{\alpha-1} e^{-\left(\frac{x}{\beta}\right)^\alpha}$$

where α and β are the shape and scale parameters respectively. It should be noted that these functions are valid for $x \geq 0$, a characteristic which determines lower bounds on groups chosen for a histogram study.

The cumulative frequency for each data point is given by the following expression

$$F(X_i) = i/1+N \quad (16)$$

where F is the cumulative frequency associated with X_i , the i th data point in ascending order. N is the total number of data points.

This particular choice of $F(X)$ forces the function to pass through the median which forces an equal number of data points to fall above and below the median value on a graph of $F(X)$ vs. X . Cumulative frequency values are represented in the array F .

3.2.5 Calculation of Statistical Parameters (6-8, 10, 11) [12,14]

Several values which are of interest when studying a particular distribution are the range, mean, median, standard deviation, and coefficient of variation. The range is calculated by taking the difference of the largest and smallest data values. That is, $R = X(N) - X(1)$ for ascending values. The mean or average is the sum of the data values divided by the number of data points. It is represented by Q .

The median of a ranked group of numbers is defined as the middle value or the mean of the two middle values. It is in a position such that the number of data values, which are greater than its value is equal to the number of data values which are less than its value. For N odd, the median would be given by $X(N+1/2)$. For N even, the median is given by the average of $X(N/2)$ and $X(N/2+1)$. It is represented by DMED in the program.

The standard deviation (STDDEV) is given by:

$$\sigma = \sqrt{\frac{\sum_{i=1}^N (X_i - X_m)^2}{N}}$$

where X_i is the i th data value and X_m is the mean.

3.2.6 *Group Width Calculation*

The group width designates the width of each section used on a histogram plot. Its size is arbitrary and the following discussion outlines the reasons for its particular selection in this program.

ΔX , the width, designated by STEP in the program is simply given by $X(N)/N2$, the largest data value divided by the desired number of groups. Another method of selection might be defining ΔX as the range divided by the desired number of groups. A histogram is a very arbitrary plot in any case, and the width chosen here seems to be as appropriate as any other.

3.2.7 *Group Boundaries Calculated; Number of Data Points in Each Group Determined (14, 15) Mid-Values of Groups Calculated (18)*

Selection of group boundaries for a histogram plot is, like the group width, a somewhat arbitrary choice. That is, as far as selecting the lower boundary limit of the first group is concerned. After that selection is made all other boundaries are defined by the group width.

The lower limit of the first group is taken to be 0.0. This means that all data values must be greater than 0.0 which is a characteristic of the Weibull distribution. Other statistical functions might have data values lying on both sides of the dependent variable axis. The value of STEP is added to 0.0 to get the first upper boundary, and each succeeding limit is determined by adding the value of STEP again.

Each data point is then checked to see which group it lies in and the total number of data points in each group is recorded. In some instances computer round-off errors cause less data points to be included in the last group than actually exists. To check for this the total data points in the groups is determined by summing the number of points in each group. If this sum is less than N, the total number of data points, enough points are added to the last group sub-total to correct the error.

When checking to see whether or not a data value falls between two boundaries the upper limit is inclusive whereas the lower limit is not (except for 0.0, which is inclusive). The mid-value of each group is found by averaging the boundaries of the group. The number of data points in each group is represented by the array T, whereas mid-values are represented by VM.

3.2.8 Shape and Scale Parameters Calculated (16,17)

In order to solve for α and β , the shape and scale parameters, the following relationship is used:

$$\ln \{ \ln \{ 1/(1 - F(X)) \} \} = \alpha \ln x - \alpha \ln \beta \quad (18)$$

which is easily derivable from the defining equation for F(x). In this expression X represents an individual data value and F(X) is its associated empirical cumulative frequency value. That is, for $X=X_i$, $F(X) = i/N+1$. This relationship indicates that $\ln \{ \ln \{ 1/(1-F(X)) \} \}$ is a

linear function of $\ln X$. Therefore if the two functions are plotted on an appropriately scaled graph a straight line will result. In order to determine α and β a least-squares curve fit will be used.

The first step is to transform $F(X)$ and X into their respective functions of the natural logarithm. Inspecting the relationship again, it can be shown that the slope of the line is given by α and the intercept is $-\alpha \ln \beta$. Let

$$F_{1i} = \ln \{ \ln \{ 1/(1-F(X_i)) \} \} \quad (19)$$

$$F_{2i} = \ln(X_i) \quad (20)$$

Then for $y = mx + b$, $y = F_{2i}$, $X = F_{1i}$, $m = \alpha$, and $b = -\alpha \ln \beta$. The following relationships are true for the linear curve fit procedure:

$$\alpha = [N \sum_{i=1}^N F_{1i} F_{2i} - \sum_{i=1}^N F_{2i} \sum_{i=1}^N F_{1i}] / [N \sum_{i=1}^N (F_{2i})^2 - (\sum_{i=1}^N F_{2i})^2] \quad (2.8)$$

$$-\alpha \ln \beta = [\sum_{i=1}^N (F_{2i})^2 \sum_{i=1}^N F_{1i} - \sum_{i=1}^N F_{2i} \sum_{i=1}^N F_{2i} F_{1i}] / [N \sum_{i=1}^N (F_{2i})^2 - (\sum_{i=1}^N F_{2i})^2] \quad (2.9)$$

If the righthandside of the above expression is given as Q , then

$$\beta = 1/\text{EXP}(Q/\alpha) \quad (21)$$

3.2.9 Theoretical Frequency of Individual Data Points (19)

The individual frequencies for each data point are derived from the theoretical distribution. What this value represents for each point is the number of times it would appear in a group of N specimens as predicted by the Weibull distribution defined by the α and β previously

calculated. These frequency values are known as the expected frequency values and will be used in a goodness-of-fit calculation later in the program.

Consider the frequency density function, $f(x)$. It has been defined in one way as

$$f(x) = dF(x)/dx \quad (22)$$

The upper limit of this function is ∞ and the lower limit 0. The following is therefore true:

$$\int_0^{\infty} f(x) dx = F(\infty) - F(0) = 1.0 \quad (23)$$

That is, the total cumulative frequency is 100% or 1.0. This total is made up, theoretically, of a summation of an infinite number of $f(x)$ values multiplied by an infinitesimal width dx . Actually, we have a finite number of $f(x)$ values (that is, a finite number of X values). Because of this, it follows that dx becomes ΔX , a finite width. Therefore there actually exists a series of $f(X_i) \Delta X_i$ which, when summed, total 1.0, the cumulative frequency over the entire range of X_i values.

Theoretically

$$\int_a^b f(x) dx = F(b) - F(a) \quad (24)$$

This is illustrated by the graph given below:

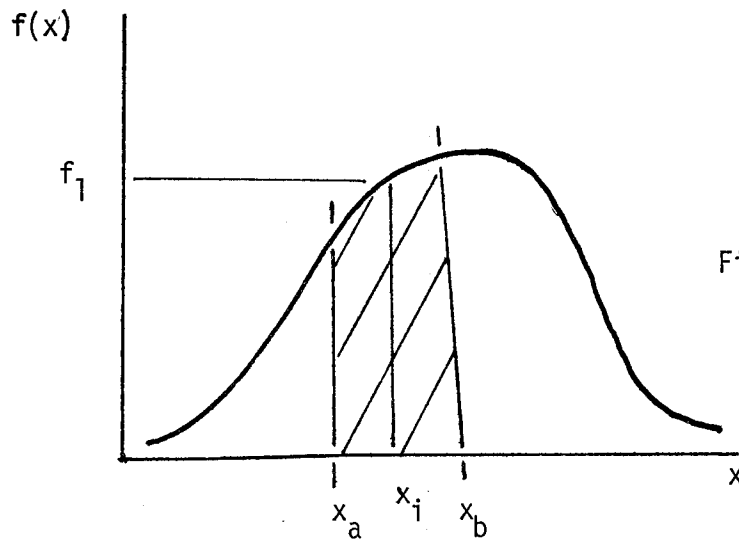

Figure 9: Cumulative Frequency

The area under $f(x)$ from a to b represents the total percent of data values which falls between x_b and x_a . That is, given an infinite population the percentage of values which fall between x_b and x_a is equal to $F(b)-F(a)$. For a finite population, this area will be used to represent the percentage for a single data value. For the above graph this value would be X_i . The question is: "For an X_i in a population of N values, how are x_a and x_b determined so as to give a good representation of $F(b)-F(a)$?" The choice is quite arbitrary, and the following has been chosen for use in this program. Consider the graph below:

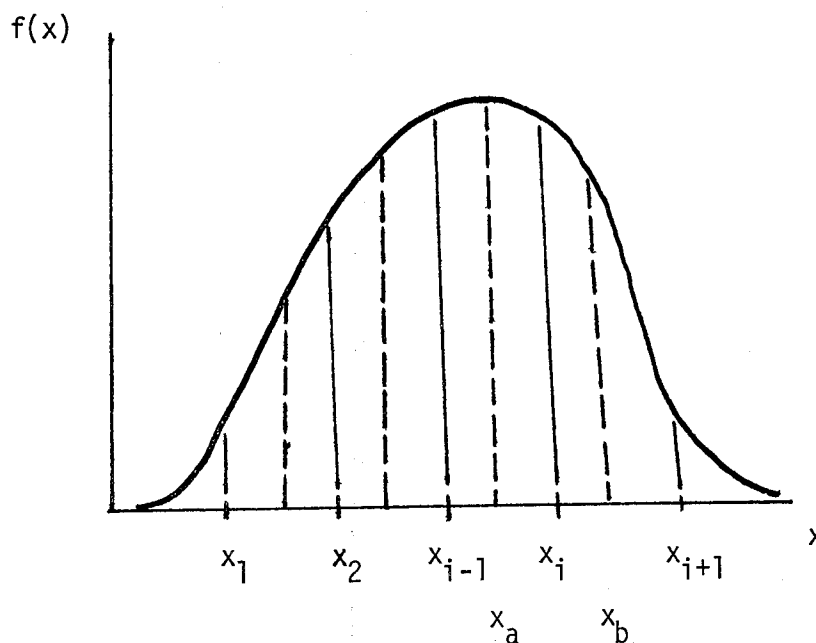

Figure 10: Frequency Groups

For any x_i , a given data value, x_a and x_b , the limits which determine $F(a)$ and $F(b)$, are given as the mid-points between x_i and x_{i-1} , and x_{i+1} and x_i respectively. This would imply that

$$F(b)-F(a) = F\left(\frac{x_{i+1} + x_i}{2}\right) - F\left(\frac{x_i + x_{i-1}}{2}\right) \quad (25)$$

= expected frequency of x_i

For $F(x) = 1 - e^{-\frac{x}{\beta}^\alpha}$

$$F(b)-F(a) = e^{-\left(\frac{x_a}{\beta}\right)^\alpha} - e^{-\left(\frac{x_b}{\beta}\right)^\alpha} \quad (26)$$

This is the calculation method used by the program to give expected frequency values for individual data points. The individual frequencies are represented by the array P and are listed under 'CALC FREQ'.

3.2.10 Calculated Frequency of Each Group (20)

These values represent the total percentiles for the groups defined previously. All they represent are the summation of the individual frequencies calculated over the total data points in any particular group.

The program checks each group to see if it contains data points. The first group to contain data points may have m values, $m \leq n$. Then the first m individual frequencies are summed. The next group to have a non-zero number of data values, say ℓ values, then has the next ℓ individual frequencies summed.

These values are represented by F11(I), and are printed out in 'Calc Freq in Group.'

3.2.11 Observed Frequency Calculation for Each Group (21)

For each data point, the observed frequency is given by $1/N+1$. This is consistent with the choice of $F(X_i) = i/N+1$ for cumulative frequency value. For a group, the total number of data values in that group is determined and multiplied by $1/N+1$. These values are represented by T1(I) and are listed under 'OBS Freq in Group'.

3.2.12 Chi-Square Calculation (23) [14]

The goodness-of-fit test which will be used in this program is the Chi-Square (χ^2) test. Although for a smaller number of data points the Komarov-Smirnoff test may be better, the Chi-Square test has been chosen due to its wide applicability and the relative ease by which the value of Chi-square and its associated confidence level can be calculated.

The value of χ^2 for a given function is defined as:

$$\chi^2 = \sum_{i=1}^N \frac{(O_i - e_i)^2}{e_i} \quad (27)$$

where O_i = observed frequency for data point i ($=1/N+1$)

e_i = expected frequency for data point i

This value is represented by CHISQ and is printed out under the title 'Calc Chi-Square'.

3.2.13 Confidence Level of Calculated Chi-Square (24)

In order to determine the confidence level for which the calculated chi-square is a critical value the area beneath a chi-square curve is determined. If the total area under the curve is normalized then the area under any portion from 0 to some value of χ^2 represents the confidence level of any value of χ^2 and an associated number of data points is given by the following expressions:

For N even:

$$Q(\chi^2|N) = 2Q(\chi) + sZ(\chi) \sum_{r=1}^{\frac{N-2}{2}} \frac{\chi^{2r-1}}{1 \cdot 3 \cdot 5 \dots (2r-1)} \quad (28)$$

$$\chi = \sqrt{\chi^2}$$

For N odd:

$$Q(\chi^2|N) = \sqrt{2\pi} Z(\chi) \left[1 + \sum_{r=1}^{\frac{N-3}{2}} \frac{\chi^{2r}}{2 \cdot 4 \dots (2r)} \right] \quad (29)$$

where: $Q(\chi^2|N)$ represents the confidence level

$$Z(\chi) = \frac{1}{\sqrt{2\pi}} e^{-\chi^2/2} \quad (30)$$

$$Q(\chi) = \frac{1}{\sqrt{2\pi}} \int_{\chi}^{\infty} e^{-t^2/2} dt = \int_{\chi}^{\infty} Z(t) dt \quad (31)$$

Because the form of $Q(\chi)$ given above is in terms of a non-integrable function, the following approximation is made:

$$Q(x) = Z(x) \frac{1}{x+1} \frac{1}{x+2} \frac{2}{x+3} \frac{3}{x+4} \frac{4}{x+5} \dots, \quad (32)$$

a continued fraction expansion. This is expressed as the following

$$\frac{1}{x+1} \frac{1}{\frac{x+2}{x+1}} \frac{2}{\frac{x+3}{\frac{x+2}{x+1}}} \dots \quad (33)$$

This infinite summation is used to calculate $Q(\)$ in the program. At this time the error limit is given as .0001. If this is found to be too large it can easily be altered (card 232).

In summary then, the following is used to calculate the confidence levels:

N even:

$$Q(x^2/N) = \frac{2}{\sqrt{2\pi}} e^{-x^2/2} \left\{ \frac{1}{x+1} \frac{1}{x+2} \frac{2}{x+3} \frac{3}{x+4} \frac{4}{x+5} \dots \right\} + \frac{2}{\sqrt{2\pi}} e^{-x^2/2} \sum_{r=1}^{N-2} \frac{x^{2r-1}}{1 \cdot 3 \cdot 5 \dots (2r-1)} \quad (34)$$

N odd:

$$Q(x^2/N) = e^{-x^2/2} \left\{ 1 + \sum_{r=1}^{N-3} \frac{x^{2r}}{2 \cdot 4 \dots (2r)} \right\} \quad (35)$$

$Q(x^2/N)$ is represented by Q2 in the program.

3.2.14 Comparison of Calculated and Selected Chi-Square Values (26)

The calculated value of chi-square is compared to the selected critical value of chi-square. This can also be done by the operator as both values are printed out along with the calculated confidence level.

After comparing the two numbers, a comment is printed out regarding the comparison. Basically the comments read as follows:

- 1) if the calculated chi-square is the larger of the two then at the selected confidence level for the $N-1$ degrees of freedom the distribution found by the program is not good enough. This probably means that
 - a) too few data points exist for a good fit or
 - b) the scatter is such that the Weibull distribution is not an appropriate descriptive function
- 2) if the calculated chi-square is the smaller of the two than at the selected confidence level for the $N-1$ degrees of freedom the distribution found by the program is a good description. (One might note, however, that a calculated chi-square which is too small, and consequently a confidence level about 1.0, may also indicate something is wrong with either the distribution or the data selection.)

3.3 Program Description

In order to give the reader a quick but clear description of the attached computer program, the following will be used as a presentation guideline:

- 1) The program operations, either I/O or internal functions, will be listed in the order in which they are performed.
- 2) These operations will be accompanied by card numbers corresponding to the program listing.
- 3) A complete program description will be given. The major operations on the sequence list will be described as to how the operation is done and why it is done that way. In the case of input the format used will be described in detail.
- 4) Immediately following the description titles will be given the item number(s) of the appropriate sequence listing.
- 5) Following item number(s) will be a list of possible references for further discussion. (Each description will not necessarily have a reference listed.) The references are given by numbers and listed together at the end.

In general, each major operation or group of similar operations (internal) will be followed immediately by its associated print statements in the program listing. This will provide additional continuity to the listing. In some cases, the print-out will follow later in the program. This provides output continuity.

3.4 Sequence of Program Operations

- 1) Reads number of values, number of groups, data values, selected critical chi-square value, and associated confidence limit.
9-13
- 2) Writes out number of values, number of groups, and data values as input.
19-24
- 3) Data values are sorted in ascending order.
35-46
- 4) Cumulative frequency values are calculated for each data point.
47-48
- 5) Ranked data values paired with cumulative frequency values are printed.
49-50
- 6) The mean is calculated.
57-60
- 7) The range is calculated.
61
- 8) The median is calculated.
62-69
- 9) Items 6 to 8 are printed out.
70-71
- 10) Standard deviation is calculated.
72-75
- 11) Coefficient of variation is calculated.
76

- 12) Items 10 and 11 are printed out.
77-78
- 13) A histogram group width is calculated.
88
- 14) The number of data points in each group is calculated.
89-109
- 15) The group boundaries are calculated, and along with the group number and the number of data points in each group, is listed.
110-117
- 16) Transformation of data values and cumulative frequency values to functions of natural logarithm.
127-131
- 17) Determination of α and β through a linear curve fit.
136-154
- 18) The mid-value of each group is calculated.
155-157
- 19) The individual theoretical frequency of each data point is calculated.
161-168
- 20) The theoretical frequency of each group is calculated.
169-184
- 21) The observed frequency in each group is calculated. Group numbers, observed and theoretical frequencies for each group are printed out.
185-190

- 22) Distribution characteristics are printed out. These include α , β , data point numbers, data values, and individual theoretical frequencies.
191-199
- 23) The value of chi-square is calculated.
213-215
- 24) The confidence level for the calculated chi-square value is determined.
220-255
- 25) The selected chi-square, its associated confidence level and the calculated chi-square with its associated confidence level are printed out.
256-261
- 26) The calculated chi-square value is compared to the selected critical value.
272
- 27) A statement concerning the relative sizes of the selected and calculated chi-square values is printed out.
273-281

3.5 Program Variables

The following is a summary of the pertinent variables in the program, their program symbols, and their output readings.

<i>Variable</i>	<i>Program Designation</i>	<i>Output Heading</i>
no. of data pts.	N	No. of data pts.
no. of groups	N2	No. of groups
data values	array X	Data- as input & in ascending values
cumulative frequency i/N+1	array F	Paired with ascending data values
Mean	Q	mean
Range	R	range
Median	DMED	median
Standard diviation	STDDEV	Std. Dev.
Coefficient of variation	CVAR	CVAR
Lower group limit	array B1	Low Lim (Not Inc)
Upper group limit	array B2	UP Lim (Inc)
Data pts. in group	array T	data pts. in group
Group mid-value	array VM	mid-value
Observed frequency in group	array T1	OBS Freq in group
calculated frequency in group	array F11	CALC req in group
Alpha	Alpha	Alpha
Beta	Beta	Beta
Individual calculated frequency	array P	CALC freq
Selected critical χ^2	CHCRIT	Selected Chi-Square
Selected confidence level	SIGLEV	Selected Conf Level
Calculated Chi-Square	CHISQ	CALC Chi-Square
Calculated confidence level	Q2	CALC conf level

In addition, the following variables appear in the program but are not output

array Z = $\ln(X(I))$

array F1 = $\ln(\ln(1/(1-F(X(I))))$

$S_1 = \sum Z F$

$S_2 = \sum Z$

see part 8 of program description

$S_3 = \sum F$

$S_4 = \sum Z^2$

P1, Q1, and Q3 represent the continued fraction expansion (see part 13).

PROD represents the denominator in the $Q(\chi^2/N)$ summation.

SUM represents the $Q(\chi^2/N)$ summation.

P2 represents a calculated significance level $(1-Q2)$ which can be printed out of desired.

3.6 Sample Output

```

1*      DIMENSION X(100),T(100),Z(100),F(100),F1(100),P(100),VM(100)
2*      DIMENSION B1(100),B2(100)
3*      DIMENSION I1(100),F11(100)
4*      C
5*      C DATA POINTS AND THE DESIRED NUMBER OF GROUPS FOR HISTOGRAM INFORMATION
6*      C ARE INPUT. CHI-SQUARE CONFIDENCE LEVEL AND CORRESPONDING CRITICAL
7*      C VALUE ARE INPUT.
8*      C
9*      READ(5,2) N
10*     READ(5,3) N2
11*     READ(5,1) (X(I),I=1,N)
12*     READ(5,4) CHCRIT
13*     READ(5,5) SIGLEV
14*     1   FORMAT(5F10.0)
15*     2   FORMAT(I3)
16*     3   FORMAT(I3)
17*     4   FORMAT(F10.0)
18*     5   FORMAT(F10.0)
19*     WRITE(6,10)
20*     WRITE(6,11) N
21*     WRITE(6,12)
22*     WRITE(6,15) N2
23*     WRITE(6,20)
24*     WRITE(6,13) (X(I),I=1,N)
25*     10  FORMAT(' NO. OF DATA PIS. ')
26*     11  FORMAT(7X,I3)
27*     12  FORMAT('// ' NO. OF GROUPS ')
28*     15  FORMAT(5X,I3)
29*     20  FORMAT('// ' DATA - AS INPUT ')
30*     13  FORMAT(5X,5E15.5)
31*     C
32*     C A BUBBLE SORT IS PERFORMED TO RANK THE DATA ACCORDING TO ASCENDING
33*     C VALUES. THE CUMULATIVE FREQUENCY FOR EACH DATA POINT IS CALCULATED.
34*     C
35*     K=N
36*     30  I=1
37*     60  IF(X(I) .GT. X(I+1)) GO TO 40
38*     50  I=I+1
39*     IF(I .LT. K) GO TO 60
40*     K=K-1
41*     IF(K .GT. 1) GO TO 30
42*     GO TO 100
43*     40  RT=X(I+1)
44*     X(I+1)=X(I)
45*     X(I)=RT
46*     GO TO 50
47*     100 DO 800 K=1,N
48*     800 F(K)=K/(1.+N)
49*     WRITE(6,110)

```

```

50*      WRITE(6,120) (X(I),F(I),I=1,N)
51*      110      FORMAT(// '          DATA-ASCENDING VALUES PAIRED WITH CUM. FREQ. ')
52*      120      FORMAT(5X,2E15.5,F10.5,E15.5,F10.5,E15.5,F10.5)
53*      C
54*      C THE RANGE, MEAN, MEDIAN, STANDARD DEVIATION, AND COEFFICIENT OF
55*      C VARIATION ARE CALCULATED.
56*      C
57*          Q=0.
58*      DO 250 I=1,N
59*      250      Q=Q+X(I)
60*          Q=Q/N
61*          R=X(N)-X(1)
62*          V=(-1.)*N
63*          IF (V .LT. 0.) GO TO 200
64*          L1=N/2.
65*          L2=N/2.+1.
66*          D1ED=(X(L1)+X(L2))/2.
67*          GO TO 210
68*      200      L3=(N+1.)/2.
69*          D1ED=X(L3)
70*      210      WRITE(6,220)
71*          WRITE(6,230) Q,R,D1ED
72*          STUDEV=0.
73*          DO 235 I=1,N
74*      235      STUDEV=STUDEV+(X(I)-Q)**2
75*          STUDEV=SQRT(STUDEV/N)
76*          CVAR=STUDEV/Q
77*          WRITE(6,240)
78*          WRITE(6,245) STUDEV,CVAR
79*      240      FORMAT(// '          SID. DEV.          CVAR ')
80*      245      FORMAT(5X,2E15.5)
81*      220      FORMAT(// '          MEAN          RANGE          MEDIAN ')
82*      230      FORMAT(5X,2E15.5)
83*      C
84*      C INFORMATION CONCERNING A HISTOGRAM FOR THE DATA IS PRODUCED. THIS
85*      C INCLUDES DIVIDING DATA INTO GROUPS, SELECTING THE MID-VALUE OF THE
86*      C GROUP, AND COUNTING THE NUMBER OF DATA POINTS IN EACH GROUP.
87*      C
88*          STEP=X(N)/N2
89*          DO 400 K=1,N2
90*      400      T(K)=0.
91*          J=1
92*          K=1
93*          L=0
94*      305      DO 310 I=J,N
95*          IF (X(I) .GE. STEP) GO TO 320
96*          T(K)=T(K)+1.
97*          L=L+1
98*      310      CONTINUE
99*      320      J=L+1
100*          STEP=STEP+X(N)/N2
101*          IF (STEP .GT. X(N)) GO TO 330
102*          K=K+1
103*          GO TO 305
104*      330      TOTFRE=0.
105*          DO 332 I=1,N2
106*      332      TOTFRE=TOTFRE+T(I)
107*          IF (TOTFRE .LT. N) GO TO 334

```

```

108*      GO TO 336
109*      334      T(N2)=T(N2)+(N-TOTFRF)
110*      WRITE(6,500)
111*      WRITE(6,502)
112*      WRITE(6,504)
113*      DO 520 I=1,N2
114*      B1(I)=(I-1)*X(N)/N2
115*      B2(I)=I*X(N)/N2
116*      WRITE(6,510) I,B1(I),B2(I),T(I)
117*      520      CONTINUE
118*      500      FORMAT(/'          HISTOGRAM PROPERTIES')
119*      502      FORMAT(/'      GROUP      LOW LIM      UP LIM      DATA PTS')
120*      504      FORMAT('      NO.      (NOT INC)      (INC)      IN GROUP')
121*      510      FORMAT(0X,15,2E15.5,F12.5)
122*      C
123*      C THE DATA VALUES AND CUMULATIVE FREQUENCY VALUES ARE TRANSFORMED
124*      C TO BE USED IN A LINEAR EQUATION OF THE TYPE  $LN(1/(1-F(X)))$  IS A
125*      C LINEAR FUNCTION OF  $LN(X)$ .
126*      C
127*      STEP=X(N)/N2
128*      DO 555 I=1,N
129*      555      Z(I)=ALOG(X(I))
130*      DO 810 K=1,N
131*      810      F1(K)=ALOG(ALOG(1./(1.-F(K))))
132*      C
133*      C THE VALUES OF ALPHA AND BETA, FOR  $F(X)=1-1/EXP((X/BETA)**ALPHA)$ 
134*      C ARE CALCULATED USING A LEAST SQUARES FIT.
135*      C
136*      S1=0.
137*      S2=0.
138*      S3=0.
139*      S4=0.
140*      DO 600 I=1,N
141*      600      S1=Z(I)*F1(I)+S1
142*      DO 610 I=1,N
143*      610      S2=Z(I)+S2
144*      DO 620 I=1,N
145*      620      S3=F1(I)+S3
146*      DO 630 I=1,N
147*      630      S4=Z(I)**2+S4
148*      ALPHA=(N*S1-S2*S3)/(N*S4-S2**2)
149*      BETA=(S4*S3-S2*S1)/(N*S4-S2**2)
150*      Q7=BETA/ALPHA
151*      IF(Q7 .LT. 0.) GO TO 700
152*      BETA=1./EXP(Q7)
153*      GO TO 637
154*      700      BETA=EXP(-Q7)
155*      336      STEP=X(N)/N2
156*      DO 550 I=1,N2
157*      550      VM(I)=STEP*(I-.5)
158*      C
159*      C INDIVIDUAL DATA POINT FREQUENCIES ARE CALCULATED.
160*      C
161*      K1=1
162*      A=ALPHA
163*      B5=2.*BETA
164*      MEN=1
165*      DO 650 I=2,M

```

```

166* 660 P(I)=1./EXP(((X(I)+X(I-1))/BS)**A)-1./EXP(((X(I+1)+X(I))/BS)**A)
167* P(I)=1.-1./EXP(((X(2)+X(1))/BS)**A)
168* P(N)=1./EXP(((X(N)+X(N-1))/BS)**A)
169* N4=0.
170* DO 710 I=1,N
171* 710 F11(I)=0.
172* I=1
173* 712 IF(T(I) .GT. 0.) GO TO 714
174* I=I+1
175* IF(I .GT. N) GO TO 718
176* GO TO 712
177* 714 N3=T(I)
178* DO 716 J=1,N3
179* 716 F11(I)=F11(I)+P(J+N4)
180* N4=N4+N3
181* I=I+1
182* IF(I .GT. N) GO TO 718
183* GO TO 712
184* 718 CONTINUE
185* WRITE(6,760)
186* WRITE(6,762)
187* DO 790 I=1,N
188* T1(I)=I(I)/N
189* WRITE(6,760) I,VM(1),T1(I),F11(I)
190* 790 CONTINUE
191* WRITE(6,708)
192* 637 WRITE(6,600)
193* WRITE(6,602)
194* WRITE(6,650) ALPHA,BETA
195* WRITE(6,632)
196* WRITE(6,634)
197* DO 780 I=1,N
198* WRITE(6,782) I,X(I),P(I)
199* 780 CONTINUE
200* 760 FORMAT(/' GROUP MID ORS FREQ CALC FREQ')
201* 762 FORMAT(' NO. VALUE IN GROUP IN GROUP')
202* 766 FORMAT(0x,15,3E15.5)
203* 768 FORMAT(/' DISTRIBUTION CHARACTERISTICS')
204* 640 FORMAT(/' F(X)=1-1/EXP((X/BETA)**ALPHA)')
205* 642 FORMAT(' ALPHA BETA')
206* 650 FORMAT(5x,2E15.5)
207* 832 FORMAT(/' DATA DATA CALC')
208* 834 FORMAT(' PT NO VALUE FREQ')
209* 782 FORMAT(0x,15,2E15.5)
210* C
211* C THE CHI-SQUARE VALUE FOR GOODNESS-OF-FIT TEST IS CALCULATED.
212* C
213* CHISQ=0.
214* DO 661 I=1,N
215* 661 CHISQ=CHISQ+(1./(N+1.))-P(I)**2/P(I)
216* C
217* C THE CONFIDENCE LEVEL ASSOCIATED WITH THE CALCULATED CHI-SQUARE
218* C VALUE IS DETERMINED.
219* C
220* Y2=CHISQ
221* Y=SQRT(Y2)
222* IP=SQRT(2.+3.14159)
223* D1=(-1.)**N

```

```

224*      IF (D1 .LT. 0.) GO TO 150
225*      Q1=1./(Y+1./Y)
226*      N1=2
227*  151    M=N1-1
228*      P1=N1/Y
229*      DO 152 I=1,M
230*  152    Q1=(N1-I)/(Y+P1)
231*      Q3=1./(Y+P1)
232*      IF (ABS(Q3-Q1) .LT. .0001) GO TO 153
233*      Q1=Q3
234*      N1=N1+1
235*      GO TO 151
236*  153    Q-1=N1
237*      SUM=0.
238*      M=(N-2.)/2.
239*      DO 154 L=1,M
240*      PROD=1.
241*      DO 155 K=1,L
242*  155    PROD=PROD*(2.*K-1.)
243*  154    SUM=SUM+Y**((2.*L-1.)/PROD)
244*      Q2=2.*Q1/(1P*EXP(Y2/2.))+2./(1P*-XP(Y2/2.))*SUM
245*      GO TO 156
246*  156    W=(N-3.)/2.
247*      SUM=0.
248*      DO 157 L=1,M
249*      PROD=1.
250*      DO 158 K=1,L
251*  158    PROD=PROD*2.*K
252*  157    SUM=SUM+Y2**L/PROD
253*      Q2=(1.+SUM)/EXP(Y2/2.)
254*      Q-1=Q.
255*  156    P2=1.-Q2
256*      WRITE(6,752)
257*      WRITE(6,754)
258*      WRITE(6,756) CHCRIT,SIGLEV
259*      WRITE(6,784)
260*      WRITE(6,786)
261*      WRITE(6,788) CHISO,Q2
262*  752    FORMAT(/'          SELECTED          SELECTED')
263*  754    FORMAT('          CHI-SQUARE          CONF LEVEL')
264*  756    FORMAT(0X,'15.5',F12.5)
265*  784    FORMAT(/'          CALC          CALC')
266*  786    FORMAT('          CHI-SQUARE          CONF LEVEL')
267*  788    FORMAT(0X,'15.5',F12.5)
268*      C
269*      C THE CALCULATED CHI-SQUARE VALUE IS COMPARED TO THE SELECTED VALUE.
270*      C A STATEMENT REGARDING THE COMPARISON IS PRINTED.
271*      C
272*      IF (CHISO .GT. CHCRIT) GO TO 730
273*      WRITE(6,740)
274*      WRITE(6,742)
275*      WRITE(6,744)
276*      WRITE(6,746)
277*      GO TO 750
278*  730    WRITE(6,732)
279*      WRITE(6,734)
280*      WRITE(6,736)
281*  750    CONTINUE

```

~~282* 740 FORMAT(// ' THE CALCULATED VALUE OF CHI-SQUARE IS LESS THAN OR')~~
~~283* 742 FORMAT(' EQUAL TO THE CRITICAL VALUE. THE HYPOTHESIS THAT THE')~~
~~284* 744 FORMAT(' DERIVED DISTRIBUTION FUNCTION IS GOOD CANNOT BE')~~
~~285* 746 FORMAT(' REJECTED.')~~
~~286* 752 FORMAT(// ' THE CALCULATED VALUE OF CHI-SQUARE IS GREATER THAN')~~
~~287* 754 FORMAT(' THE CRITICAL VALUE. THE HYPOTHESIS THAT THE DERIVED')~~
~~288* 756 FORMAT(' DISTRIBUTION FUNCTION IS GOOD MUST BE REJECTED.')~~
289* END

NO. OF DATA PTS.
14

NO. OF GROUPS
14

DATA AS INPUT

.37000+05	.37000+05	.39000+05	.40000+05	.42000+05
.43000+05	.45000+05	.46000+05	.46000+05	.48000+05
.50000+05	.51000+05	.54000+05	.55000+05	

DATA ASCENDING VALUES PAIRED WITH CUM. FREQ.

.37000+05	.06667	.37000+05	.13333	.39000+05	.20000
.40000+05	.26667	.42000+05	.33333	.43000+05	.40000
.45000+05	.46667	.46000+05	.53333	.46000+05	.60000
.48000+05	.66667	.50000+05	.73333	.51000+05	.80000
.54000+05	.86667	.55000+05	.93333		

MEAN .45214+05 RANGE .18000+05 MEDIAN .45000+05

STD. DEV. .56968+04 CV .12600+00

HISTOGRAM PROPERTIES

GROUP NO.	LOW LIM (NOT INC)	UP LIM (INC)	DATA PTS IN GROUP
1	.00000	.39286+04	.00000
2	.39286+04	.78571+04	.00000
3	.78571+04	.11786+05	.00000
4	.11786+05	.15714+05	.00000
5	.15714+05	.19643+05	.00000
6	.19643+05	.23571+05	.00000
7	.23571+05	.27500+05	.00000
8	.27500+05	.31429+05	.00000
9	.31429+05	.35357+05	.00000
10	.35357+05	.39286+05	3.00000
11	.39286+05	.43214+05	3.00000
12	.43214+05	.47143+05	3.00000
13	.47143+05	.51071+05	3.00000
14	.51071+05	.55000+05	2.00000

GROUP NO.	MID VALUE	OBS FREQ IN GROUP	CALC FREQ IN GROUP
1	.19643+04	.00000	.00000
2	.58929+04	.00000	.00000
3	.98214+04	.00000	.00000
4	.13750+05	.00000	.00000
5	.17679+05	.00000	.00000
6	.21607+05	.00000	.00000
7	.25536+05	.00000	.00000

8	.29464+05	.00000	.00000
9	.33393+05	.00000	.00000
10	.37321+05	.21429+00	.19954+00
11	.41250+05	.21429+00	.20385+00
12	.45179+05	.21429+00	.17515+00
13	.49107+05	.21429+00	.29250+00
14	.53036+05	.14286+00	.12885+00

DISTRIBUTION CHARACTERISTICS

$$F(x) = 1 - 1/\text{EXP}((x/\text{BETA}) ** \text{ALPHA})$$

ALPHA	BETA
.78006+01	.47887+05

DATA PT NO	DATA VALUE	CALC FREQ
1	.37000+05	.12517+00
2	.37000+05	.26636+01
3	.39000+05	.47835+01
4	.40000+05	.57935+01
5	.42000+05	.68197+01
6	.43000+05	.77721+01
7	.45000+05	.85351+01
8	.45000+05	.29639+01
9	.46000+05	.60170+01
10	.48000+05	.11904+00
11	.50000+05	.62186+01
12	.51000+05	.91287+01
13	.54000+05	.64473+01
14	.55000+05	.64376+01

SELECTED	SELECTED
CHI-SQUARE	CONF LEVEL
.23600+02	.99500

CALC	CALC
CHI-SQUARE	CONF LEVEL
.18167+00	1.00004

THE CALCULATED VALUE OF CHI-SQUARE IS LESS THAN OR EQUAL TO THE CRITICAL VALUE. THE HYPOTHESIS THAT THE DERIVED DISTRIBUTION FUNCTION IS GOOD CANNOT BE REJECTED.

CHAPTER IV

TENSION OF AN ANISOTROPIC PLATE WITH ELLIPTIC CUTOUT

4.1 Introduction

Consider an infinite two-dimensional plate with an elliptic cutout, subjected to uniform tension at an angle ϕ . The dimensions of the cutout and manner of loading are shown in Figure 8. The solution may be obtained by superposition of the solution to two problems. The first problem is an infinite plate with no cutout and tension at an angle ϕ ; the second problem is a plate with an elliptical cutout with no loading at infinity, but tractions applied along the cutout surface corresponding to a uniform stress at infinity. These two solutions combine to give a stress-free elliptical boundary (see Figure 9).

4.2 Problem Solution: First Problem

The solution to the first problem is a uniform stress given by equations (36) below.

$$\begin{aligned}\sigma_x &= p \cos^2 \phi \\ \sigma_y &= p \sin^2 \phi \\ \tau_{xy} &= p \sin \phi \cos \phi\end{aligned}\tag{36}$$

Problem Solution: Second Problem

The second problem will be solved using the stress function method of Lekhnitskii [15]. Stresses and displacements are obtained in terms of the stress function $\phi_k(Z_k)$ and its derivatives with respect to Z_k .

$$\begin{aligned}\sigma_x &= 2\text{Re}[\mu_1^2\phi_1' + \mu_2^2\phi_2'] \\ \sigma_y &= 2\text{Re}[\phi_1' + \phi_2']\end{aligned}\quad (37)$$

$$\begin{aligned}\tau_{xy} &= -2\text{Re}[\mu_1\phi_1' + \mu_2\phi_2'] \\ u &= 2\text{Re}[\rho_1\phi_1 + \rho_2\phi_2] \\ v &= 2\text{Re}[q_1\phi_1 + q_2\phi_2]\end{aligned}\quad (38)$$

The parameters p and q of equations (38) are functions only of the material compliances β_{ij} and the roots μ_k of the characteristic equation for the material.

$$\beta_{11}\mu^4 - 2\beta_{16}\mu^3 + (2\beta_{12} + \beta_{66})\mu^2 - 2\beta_{26}\mu + \beta_{22} = 0 \quad (39)$$

$$\begin{aligned}p_1 &= \beta_{11}\mu_1^2 + \beta_{12} - \beta_{16}\mu_1 \\ p_2 &= \beta_{11}\mu_2^2 + \beta_{12} - \beta_{16}\mu_2 \\ q_1 &= \beta_{12}\mu_1 + \beta_{22}/\mu_1 - \beta_{26} \\ q_2 &= \beta_{12}\mu_2 + \beta_{22}/\mu_2 - \beta_{26}\end{aligned}\quad (40)$$

The constitutive relations employed assume only that the material is midplane symmetric; otherwise the material may be generally anisotropic. The roots of the characteristic equation are in general obtained numerically, as, for example in reference [16].

The Z_k coordinate frame results from a linear transformation from x - y space, where μ_1 and μ_2 are solutions to the characteristic equation.

$$\begin{aligned}Z_1 &= x + \mu_1 y \\ Z_2 &= x + \mu_2 y\end{aligned}\quad (41)$$

The stress function may be represented as an infinite series in the variable ξ_k , as:

$$\phi_k = A_k \log \xi_k + \sum_{n=1}^{\infty} A_{kn} \xi_k^{-n} \quad (42)$$

The variable ξ_k is the result of a conformal mapping of Z_k , such that the elliptic boundary maps onto the unit circle. The mapping is given by:

$$\xi_k = (Z_k \pm \sqrt{Z_k^2 - a^2 - \mu_k^2 b^2}) / (a - i\mu_k b) \quad (43)$$

The problem is now reduced to the determination of the stress function ϕ_k . Since the net load on the interior boundary is zero the coefficients A_k reduce to zero. The remaining coefficients A_{kn} are determined from the boundary tractions on the cutout, which may be represented by a Laurent series.

The boundary stresses are related to the surface tractions by

$$T_x = \sigma_x^* n_x + \tau_{xy}^* n_y \quad (44)$$

$$T_y = \tau_{xy}^* n_x + \sigma_y^* n_y$$

The components of the unit normal to the cutout surface must now be determined. The equation of the ellipse may be given in parametric form as:

$$x = a \cos \theta$$

$$y = b \sin \theta \quad (45)$$

Consider an incremental arc length dS along the elliptic surface (see Figure 11).

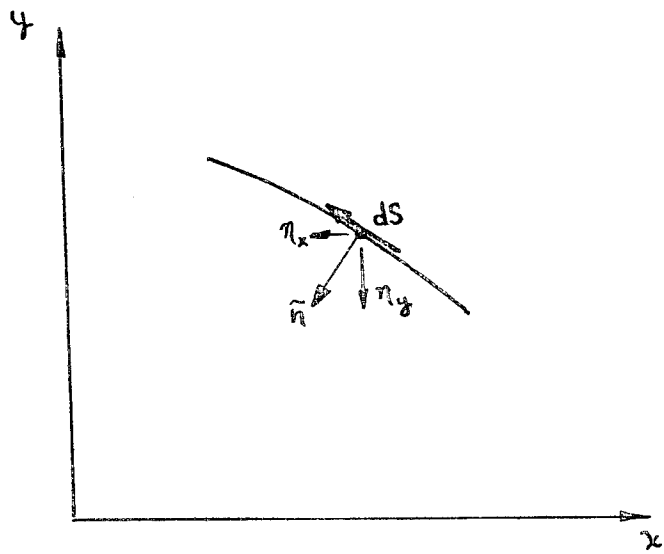

Figure 11: Local Coordinates

$$dx = -a \sin\theta \, d\theta \quad (46)$$

$$dy = b \cos\theta \, d\theta$$

$$n_x = dy/dS \quad (47)$$

$$n_y = -dx/dS$$

The stresses σ_x^* , σ_y^* and τ_{xy}^* at the boundary of the cutout are known, since they must correspond to a uniform stress applied at infinity, so from equation (36):

$$\begin{aligned} \sigma_x^* &= -p \cos\phi \\ \sigma_y^* &= -p \sin\phi \\ \tau_{xy}^* &= -p \sin\phi \cos\phi \end{aligned} \quad (48)$$

The boundary tractions are now fully determined:

$$T_x = \sigma_x^* \frac{dy}{dS} - \tau_{xy}^* \frac{dx}{dS} \quad (49)$$

$$T_y = \tau_{xy}^* \frac{dy}{dS} - \sigma_y^* \frac{dx}{dS}$$

The boundary tractions can be shown to have the following relationship with the coefficients of the stress functions.

$$\begin{aligned} \int (T_x + iT_y) \, dS &= -(P_x + iP_y) \frac{\theta}{2\pi} \\ &+ \sum_{m=1}^{\infty} [(\mu_1 - i) A_{1m} + (\mu_2 - i) A_{2m}] e^{-im\theta} \\ &+ \sum_{n=1}^{\infty} [(\bar{\mu}_1 - i) \bar{A}_{1n} + (\bar{\mu}_2 - i) \bar{A}_{2n}] e^{-in\theta} \end{aligned} \quad (50)$$

Representing the integral above in terms of a Laurent series, it is possible to solve explicitly for the coefficients needed for the stress function.

$$\int (T_x + iT_y) dS = B_0 \theta + \sum_{n=1}^{\infty} B_n e^{in\theta} + \sum_{m=1}^{\infty} D_m e^{-im\theta} \quad (51)$$

$$A_{1m} = \frac{1+i\mu_2}{2(\mu_1-\mu_2)} \bar{B}_m + \frac{(1-i\mu_2)}{2(\mu_1-\mu_2)} D_m \quad (52)$$

$$A_{2m} = \frac{1+i\mu_1}{2(\mu_2-\mu_1)} \bar{B}_m + \frac{(1-i\mu_1)}{2(\mu_2-\mu_1)} D_m$$

Returning to the expressions for the boundary tractions (49) the value of the integral in (51) is computed.

$$\begin{aligned} \int (T_x + iT_y) dS &= \left(\sigma_x^* \frac{dy}{dS} - \tau_{xy}^* \frac{dx}{dS} + i\tau_{xy}^* \frac{dy}{dS} - i\sigma_y^* \frac{dx}{dS} \right) dS \\ &= \int -(\tau_{xy}^* + i\sigma_y^*) dx + (\sigma_x^* + i\tau_{xy}^*) dy \\ &= \int +(\tau_{xy}^* + i\sigma_y^*) a \sin\theta d\theta + (\sigma_x^* + i\tau_{xy}^*) b \cos\theta d\theta \\ &= -(\tau_{xy}^* + i\sigma_y^*) a \cos\theta + (\sigma_x^* + i\tau_{xy}^*) b \sin\theta + k \end{aligned}$$

$$\begin{aligned} \int (T_x + iT_y) dS &= \left[\frac{\tau_{xy}^*(b-a)}{2} - i \frac{(a\sigma_y^* + b\sigma_x^*)}{2} \right] e^{i\theta} \\ &- \left[\frac{\tau_{xy}^*(a+b)}{2} + i \frac{(a\sigma_y^* - b\sigma_x^*)}{2} \right] e^{-i\theta} \end{aligned} \quad (53)$$

The coefficients of the Laurent series of (51) are now easily calculated, and lead directly to the coefficients of the stress function.

$$B_1 = \frac{\tau_{xy}^*(b-a)}{2} - \frac{i(a\sigma_y^* + b\sigma_x^*)}{2} \quad (54)$$

$$D_1 = \frac{-\tau_{xy}^*(a+b)}{2} - \frac{i(a\sigma_y^* - b\sigma_x^*)}{2}$$

$$B_n = 0 \text{ for } n \geq 2$$

$$D_n = 0 \text{ for } n \geq 2$$

$$A_{11} = \frac{1 + i\mu_2}{2(\mu_1 - \mu_2)} \bar{B}_1 + \frac{1 - i\mu_2}{2(\mu_1 - \mu_2)} D_1 \quad (55)$$

$$A_{21} = \frac{1 + i\mu_1}{2(\mu_2 - \mu_1)} \bar{B}_1 + \frac{1 - i\mu_1}{2(\mu_2 - \mu_1)} D_1$$

$$A_{1n} = A_{2n} = 0 \text{ for } n \geq 2$$

The stress function is now fully determined, and may be differentiated to obtain the required stresses.

$$\phi_1(\xi_1) = A_{11}\xi_1^{-1} \quad \phi_2(\xi_2) = A_{21}\xi_2^{-1} \quad (56)$$

$$\phi_k' = d\phi_k/dZ_k = (\partial\phi_k/\partial\xi_k) (\partial\xi_k/\partial Z_k)$$

$$\phi_1' = (-A_{11}\xi_1^{-1}) / \sqrt{Z_1^2 - a^2 - \mu_1^2 b^2} \quad (57)$$

$$\phi_2' = (-A_{21}\xi_2^{-1}) / \sqrt{Z_2^2 - a^2 - \mu_2^2 b^2}$$

The equations (37) and (38) may now be used to obtain stresses and displacements at any point in the plate, due to a given load p .

A computer program has been written to implement this solution, and a listing appears in the next section.

4.3 Program Listing

```

C STRESS FUNCTION SOLUTION * ELLIPTIC CUTOUT IN INFINITE PLATE * JAN 72 ELP10000
C AA = SEMI-MAJOR AXIS ( X-AXIS ) ELP10005
C BB = SEMI-MINOR AXIS ( Y-AXIS ) ELP10010
C THETA D = INCLINATION ANGLE( DEG ) WITH X-AXIS OF TENSION AT INFINITY ELP10015
C PP = VALUE OF TENSION AT INFINITY ELP10020
C BETA = FLEXIBILITY MATRIX FOR MATERIAL ELP10025
C MU = SOLUTIONS TO CHARACTERISTIC EQUATION FOR MATERIAL ELP10030
COMMON / HAD / P(2), Q(2), BETA(6), MU(2) ELP10035
COMMON / GEOM / AA, BB, XCOR(55), YCOR(55) ELP10040
DIMENSION TITLE(20), X(200), Y(200), QQ(55) ELP10045
COMPLEX MU, ZETA(2), Z(2), CSIGX, CSIGY, CTAU, CU, CV, RADCL, TI, DPHI(2), ELP10050
I, PHI(2), A(2,2), B, D, P, Q ELP10055
READ (5,301) NC ELP10060
14 NC = NC - 1 ELP10065
IF( NC.LT.0) STOP ELP10070
WRITE(6,302) NC ELP10075
READ(5,101) TITLE ELP10080
WRITE(6,101) TITLE ELP10085
READ(5,102) (BETA(I) , I=1,6) ELP10090
WRITE(6,201) (BETA(I) , I=1,6) ELP10095
READ(5,103) (MU(I) , I=1,2) ELP10100
WRITE(6,202) (MU(I) , I=1,2) ELP10105
READ(5,103) AA, BB, PP, THETA D ELP10110
WRITE(6,202) AA, BB, PP, THETA D ELP10115
THETA = 3.141592653489 * THETA D / 180.0 ELP10120
TI = (0.0,1.0) ELP10125
C CALCULATE UNIFORM STRESS FIELD ELP10130
SIG1 = PP * COS(THETA) * COS(THETA) ELP10135
SIG2 = PP * SIN(THETA) * SIN(THETA) ELP10140
SIG12 = - PP * SIN(THETA) * COS(THETA) ELP10145
WRITE(6,299) SIG1, SIG2, SIG12 ELP10150
299 FORMAT( 10X,3E20.10 ) ELP10155
C CALCULATE A(K,N) ELP10160
B = .5 * SIG12 * (BB-AA) * TI + .5 * (AA*SIG2 + BB*SIG1) ELP10165
D = -.5 * SIG12 * (BB+AA) * TI + .5 * (AA*SIG2 - BB*SIG1) ELP10170
A(1,1) = (1. + TI * MU(2) ) / (2. * (MU(1) - MU(2))) * B ELP10175
1 + (1. - TI * MU(2) ) / (2. * (MU(1) - MU(2))) * D ELP10180
A(2,1) = (1. + TI * MU(1) ) / (2. * (MU(2) - MU(1))) * B ELP10185
1 + (1. - TI * MU(1) ) / (2. * (MU(2) - MU(1))) * D ELP10190
C CALCULATE P(I) AND Q(I) ELP10195
CALL CONST ELP10200
C GENERATE DESIRED INTERIOR SOLUTION POINTS ELP10205
CALL GEN(QQ) ELP10210
DO 34 J = 1,55 ELP10215
Y(J) = 0.0 ELP10220
C 34 X(J) = AA + QQ(J) ELP10225
34 X(J) = QQ(J) + 0.227 ELP10230
DO 35 JJ = 1,55 ELP10235
J = JJ + 55 ELP10240
X(J) = 0.0 ELP10245
35 Y(J) = QQ(JJ) + 1.025 ELP10250
C 35 Y(J) = BB + QQ(JJ) ELP10255
WRITE(6,204) ELP10260
DO 39 J = 1,110 ELP10265
DO 40 K = 1,2 ELP10270
KEY = 0 ELP10275
SIGN = 1.0 ELP10280

```

	Z(K) = X(J) * MU(K) * Y(J)	ELP10285
	RADCL = Z(K) * Z(K) - AA * AA - MU(K) * MU(K) * BB * BB	ELP10290
44	ZETA(K) = (Z(K) * SIGN * CSQRT(RADCL)) / (AA * TI * MU(K) * BB)	ELP10295
	IF (KEY .EQ. 1) GO TO 50	ELP10300
	RZETA = REAL(ZETA(K))	ELP10305
	YIZETA = AIMAG(ZETA(K))	ELP10310
	TM = RZETA * RZETA + YIZETA * YIZETA	ELP10315
	ZEE = SQRT(TM)	ELP10320
	ZM = 1. * ZEE	ELP10325
	IF (ZM .LT. 1.E-3) GO TO 50	ELP10330
	SIGN = - SIGN	ELP10335
	KEY = 1	ELP10340
	GO TO 44	ELP10345
50	CONTINUE	ELP10350
	PHI(K) = A(K,1) * ZETA(K)	ELP10355
40	DPHI(K) = - A(K,1) / (SIGN * CSQRT(RADCL) * ZETA(K))	ELP10360
C	CALCULATE STRESSES AND DISPLACEMENTS	ELP10365
	CSIGX = MU(1) * MU(1) * DPHI(1) + MU(2) * MU(2) * DPHI(2)	ELP10370
	CSIGY = DPHI(1) * DPHI(2)	ELP10375
	CTAU = MU(1) * DPHI(1) + MU(2) * DPHI(2)	ELP10380
	CU = P(1) * PHI(1) + PHI(2) * P(2)	ELP10385
	CV = Q(1) * PHI(1) + Q(2) * PHI(2)	ELP10390
	SIGX = 2. * REAL(CSIGX) / PP = SIG1	ELP10395
	SIGY = 2. * REAL(CSIGY) / PP = SIG2	ELP10400
	TAU = 2. * REAL(CTAU) / PP = SIG12	ELP10405
	U = 2. * REAL(CU)	ELP10410
	V = 2. * REAL(CV)	ELP10415
	WRITE(6,205) X(J),Y(J),SIGX,SIGY,TAU,U,V	ELP10420
39	CONTINUE	ELP10425
	GO TO 14	ELP10430
101	FORMAT(20A4)	ELP10435
102	FORMAT(6E13.7)	ELP10440
103	FORMAT(4E20.10)	ELP10445
201	FORMAT(1X,6E17.7)	ELP10450
202	FORMAT(1X,4E20.10)	ELP10455
204	FORMAT(//////// 6X,'X',9X,'Y',10X,'SIGX',9X,'SIGY',9X,'TAU',11X,	ELP10460
	1,'U',12X,'V',//)	ELP10465
205	FORMAT(2F10.4,3F13.7,2F14.8)	ELP10470
301	FORMAT(I3)	ELP10475
302	FORMAT(JH1, I3)	ELP10480
	END	ELP10485

```

SUBROUTINE GEN(Q)
GEYS COORDINATES FOR ELLIPTIC CUTOUT SOLUTION POINTS
COMMON / GEOM / AA, BB, XCOR(55), YCOR(55)
DIMENSION Q(55)
CHNG = .001
Q(1) = 0.0
DO 50 J = 2,55
IF(J.GT.11) CHNG = .01
IF(J.GT.20) CHNG = .10
IF(J.GT.29) CHNG = .50
IF(J.GT.45) CHNG = 1.0
IF(J.GT.50) CHNG = 5.0
N = J - 1
50 Q(J) = Q(N) + CHNG
RETURN
END

```

```

ELP15000
ELP15005
ELP15010
ELP15015
ELP15020
ELP15025
ELP15030
ELP15035
ELP15040
ELP15045
ELP15050
ELP15055
ELP15060
ELP15065
ELP15070
ELP15075

```

```

SUBROUTINE CONST
COMMON / HAD / P(2), Q(2), BETA(4), MU(2)
COMPLEX P, Q, MU
DO 6 K = 1,2
P(K) = BETA(1) * MU(K) * MU(K) + BETA(2) - BETA(3) * MU(K)
6 Q(K) = BETA(2) * MU(K) + BETA(4) / MU(K) - BETA(5)
RETURN
END

```

```

ELP20000
ELP20005
ELP20010
ELP20015
ELP20020
ELP20025
ELP20030
ELP20035

```

REFERENCES

- [1] T. A. Cruse and J. L. Swedlow, Interactive Program for Analysis and Design Problems in Advanced Composites Technology, Air Force Materials Laboratory Technical Report, AFML-TR-71-268 (December 1971).
- [2] H. J. Konish, Jr., J. L. Swedlow, and T. A. Cruse, On Fracture in Advanced Fiber Composites, *AIAA Journal*, 11, 40-43 (January 1973).
- [3] H. J. Konish, Jr., T. A. Cruse, and J. L. Swedlow, A Method for Estimating Fracture Strength of Specially Orthotropic Composite Laminates, in *ASTM STP 521*, American Society for Testing and Materials (1973).
- [4] T. A. Cruse, Tensile Strength of Notched Composites, *Journal of Composite Materials*, 7, 218-229 (April 1973).
- [5] T. A. Cruse and M. G. Stout, Fractographic Study of Graphite-Epoxy Laminated Fracture Specimens, *Journal of Composite Materials*, 7, 272-276 (April 1973).
- [6] J. P. Waszczak and T. A. Cruse, Failure Mode and Strength Predictions of Anisotropic Bolt Bearing Specimens, *Journal of Composite Materials*, 5 (July 1971).
- [7] J. P. Waszczak and T. A. Cruse, A Synthesis Procedure for Mechanically Fastened Joints in Advanced Composite Materials, submitted for publication.

- [8] T. A. Cruse, H. J. Konish, Jr., and J. P. Waszczak, Strength Analysis for Design with Composite Materials, *Proceedings of the Colloquium on Structural Reliability*, Carnegie-Mellon University, 222-236 (October 1972).
- [9] J. L. Swedlow, T. A. Cruse, and J. C. Halpin (editors), *Proceedings of the Colloquium on Structural Reliability*, Carnegie-Mellon University (October 1972).
- [10] Freudenthal, A. M., "Reliability Analysis Based on Time to First Failure", AFML-TR-67-149, (May 1967).
- [11] Gumbel, E. J., "The Statistical Theory of Extreme Values and Some Practical Applications", Applied Mathematics Series, National Bureau of Standard, Washington, D.C., 1954.
- [12] Spiegel, Murray R., "Statistics", *Schaum's Outline Series*, McGraw-Hill Book Co., 1961.
- [13] Freudenthal, Alfred M., "Statistical Approach to Brittle Fracture," in *Fracture*, Volume 2, ed. by H. Liebowitz, Academic Press, New York (1968) pp. 591-619.
- [14] Langley, Russell, *Practical Statistics*, Dover Publications, Inc., 1970.
- [15] S. G. Lekhnitskii, *Theory of Elasticity of an Anisotropic Elastic Body*, San Francisco, Holden-Day, Inc. (1963).
- [16] H. J. Konish, Jr., *Numerical Calculation of the Characteristic Parameters for a General Anisotropic Plate*, Report SM-65, Department of Mechanical Engineering, Carnegie-Mellon University, Pittsburgh, Pennsylvania (June 1971).

UNCLASSIFIED

Security Classification

DOCUMENT CONTROL DATA - R & D

(Security classification of title, body of abstract and indexing annotation must be entered when the overall report is classified)

1. ORIGINATING ACTIVITY (Corporate author) Carnegie-Mellon University Mechanical Engineering Department Pittsburgh, Pennsylvania 15213		2a. REPORT SECURITY CLASSIFICATION UNCLASSIFIED	
		2b. GROUP N/A	
3. REPORT TITLE INTERACTIVE PROGRAM IN ADVANCED COMPOSITES TECHNOLOGY: "PROGRAM REVIEW"			
4. DESCRIPTIVE NOTES (Type of report and inclusive dates) Final Report (November 1971 - August 1973)			
5. AUTHOR(S) (First name, middle initial, last name) T. A. Cruse			
6. REPORT DATE September 1973		7a. TOTAL NO. OF PAGES 86	7b. NO. OF REFS 16
8a. CONTRACT OR GRANT NO F33615-72-C-1214		9a. ORIGINATOR'S REPORT NUMBER(S) SM-73-12	
b. PROJECT NO. 6169 CW		9b. OTHER REPORT NO(S) (Any other numbers that may be assigned this report) AFML-TR-73-145; Volume I	
c.			
d.			
10. DISTRIBUTION STATEMENT Approved for Public Release: Distribution Unlimited			
11. SUPPLEMENTARY NOTES		12. SPONSORING MILITARY ACTIVITY Advanced Composites Division (AFML/LC) Air Force Materials Laboratory Wright-Patterson Air Force Base, Ohio	
13. ABSTRACT The Carnegie-Mellon University team has completed the second two year program in advanced composites technology. The program has had significant impact in several areas as the CMU team, working closely with the engineers at General Dynamics, Convair Aerospace Division, Fort Worth, has continued work on several projects. The work reported herein included: continuing development of university-industry interaction; development of educational material including reports on manufacturing methods, Weibull statistics, and stresses due to an elliptical hole in an anisotropic plate; and, advanced research into synthesis procedures for mechanically fastened joints and elastic fracture mechanics for laminated composite plates. The research projects demonstrate useful design capabilities, new analytical and numerical results, and experimental data.			

14. KEY WORDS	LINK A		LINK B		LINK C	
	ROLE	WT	ROLE	WT	ROLE	WT
Composite Materials						
Education						
Manufacturing						
Statistics						
Stress Analysis						
Fracture Mechanics						
Optimization						
Synthesis						
Criteria						