

# NATIONAL AIR INTELLIGENCE CENTER



AN INTRODUCTION TO THE NATIONAL  
SATELLITE METEOROLOGICAL CENTER  
(Brochure)

SECRET



Approved for public release:  
distribution unlimited

19960408 153

**HUMAN TRANSLATION**

NAIC-ID(RS)T-0659-95      7 February 1996

MICROFICHE NR: 96C000060

AN INTRODUCTION TO THE NATIONAL  
SATELLITE METEOROLOGICAL CENTER  
(Brochure)

English pages: 39

Source: English Title (An Introduction to the National  
Satellite Meteorological Center);pp. I-IV; 1-32

Country of origin: China  
Translated by: Edward A. Suter  
Requester: NAIC/TASC/Lt Lori Thorson  
Approved for public release: distribution unlimited.

THIS TRANSLATION IS A RENDITION OF THE ORIGINAL FOREIGN TEXT WITHOUT ANY ANALYTICAL OR EDITORIAL COMMENT STATEMENTS OR THEORIES ADVOCATED OR IMPLIED ARE THOSE OF THE SOURCE AND DO NOT NECESSARILY REFLECT THE POSITION OR OPINION OF THE NATIONAL AIR INTELLIGENCE CENTER.	PREPARED BY: TRANSLATION SERVICES NATIONAL AIR INTELLIGENCE CENTER WPAFB, OHIO
--	---

**GRAPHICS DISCLAIMER**

All figures, graphics, tables, equations, etc. merged into this translation were extracted from the best quality copy available.

# DISCLAIMER NOTICE



**THIS DOCUMENT IS BEST QUALITY AVAILABLE. THE COPY FURNISHED TO DTIC CONTAINED A SIGNIFICANT NUMBER OF PAGES WHICH DO NOT REPRODUCE LEGIBLY.**

# AN INTRODUCTION TO THE NATIONAL SATELLITE METEOROLOGICAL CENTER

(Romanized title: *Guojia Weixing Qixiang Zhongxin*)

(Translation of photo captions, tables, and diagrams)

Page 4

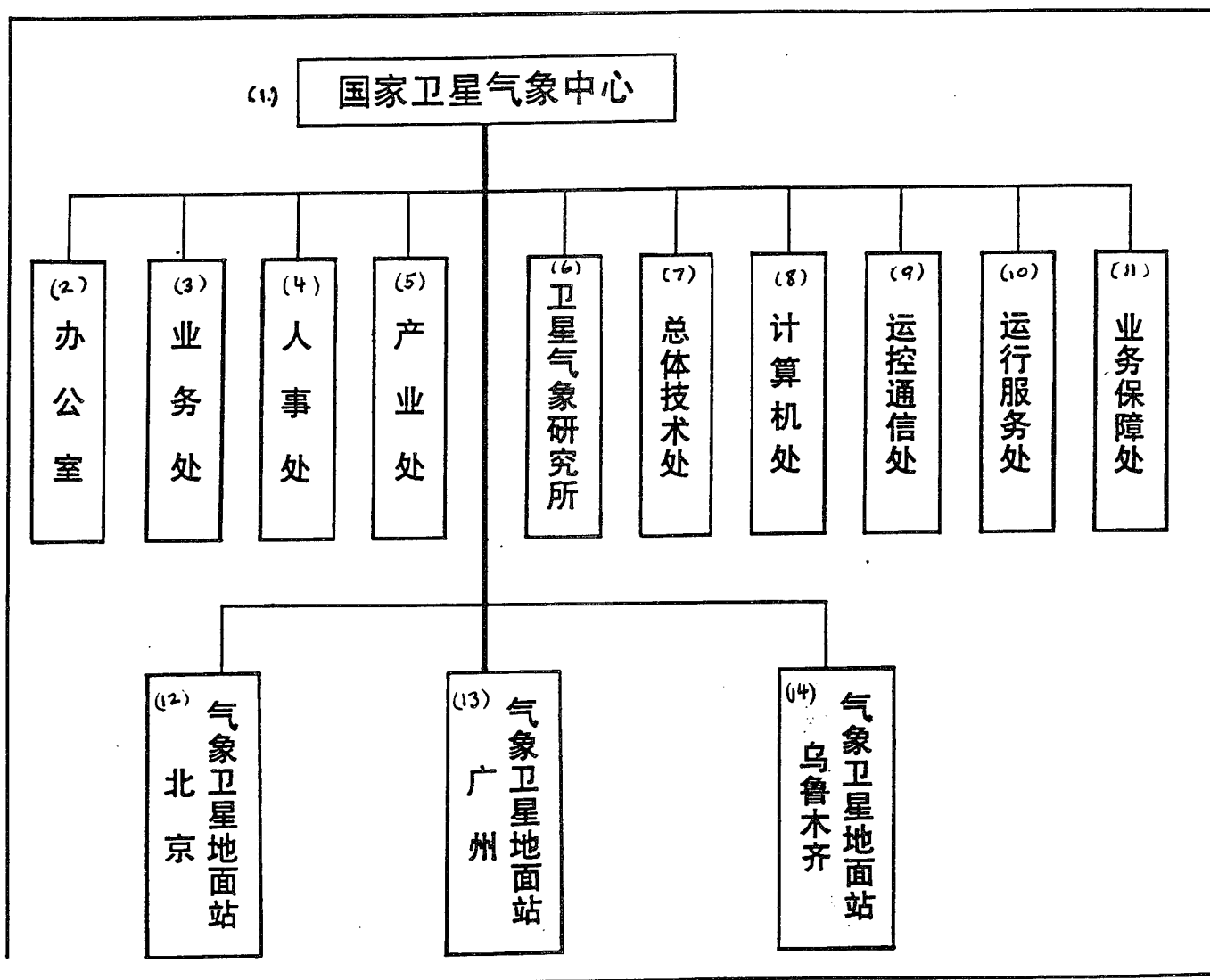

Key: (1). National Satellite Meteorological Center. (2). Office. (3). Service Department. (4). Personnel Department. (5). Production Department. (6). Satellite Meteorological Research Institute. (7). General Technological Department. (8). Computer Systems Department. (9). Operations Control and Communications Department. (10). Operations Service Department. (11). Service Support Department. (12). Beijing Meteorological Satellite Ground Station. (13). Guangzhou Meteorological Satellite Ground Station. (14). Urumqi Meteorological Satellite Ground Station.

Page 5

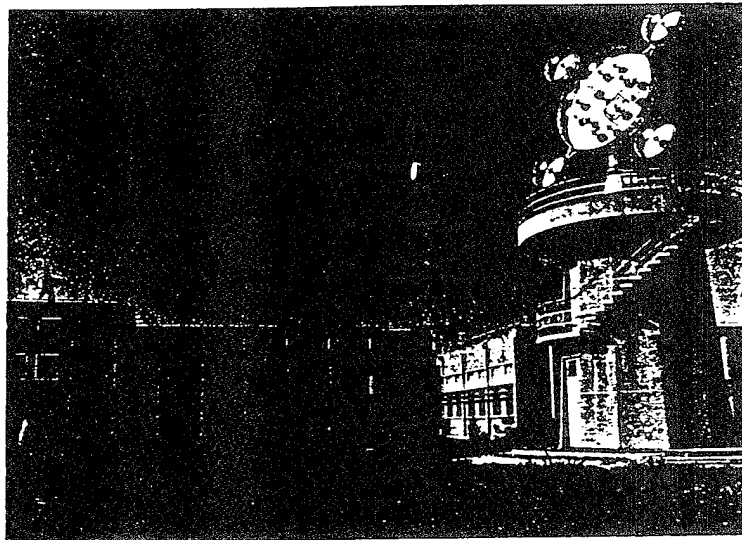

(1) 北京气象卫星地面站

Key: (1). Beijing Meteorological Satellite Ground Station

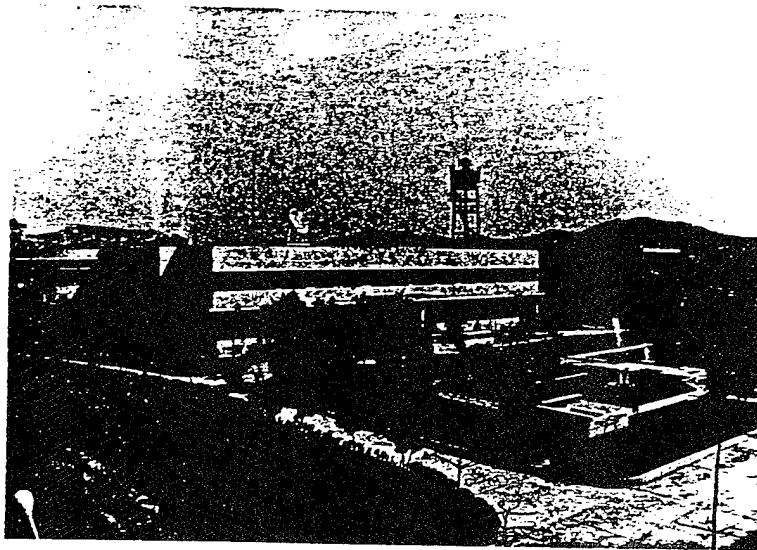

广州气象卫星地面站 (2)

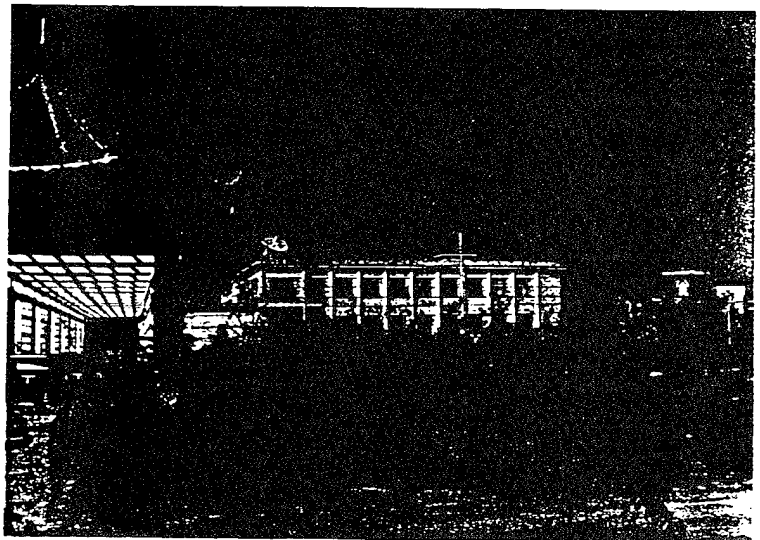

(3) 乌鲁木齐气象卫星地面站

**Key:** (2). Guangzhou Meteorological Satellite Ground Station. (3). Urumqi Meteorological Satellite Ground Station.

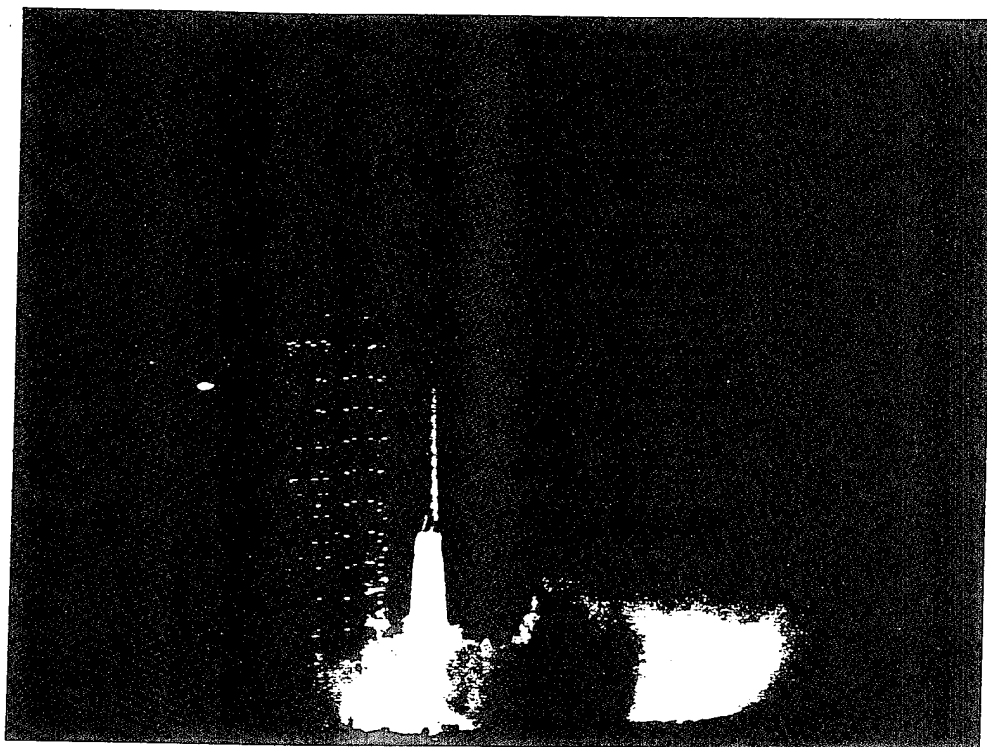

(1) “风云一号” (A) 气象卫星发射 (1988 年 9 月 7 日)

Key: (1) *Fengyun-1* [FY-1] (A) Meteorological Satellite Launching (September 7, 1988).

(i) “风云二号”气象卫星

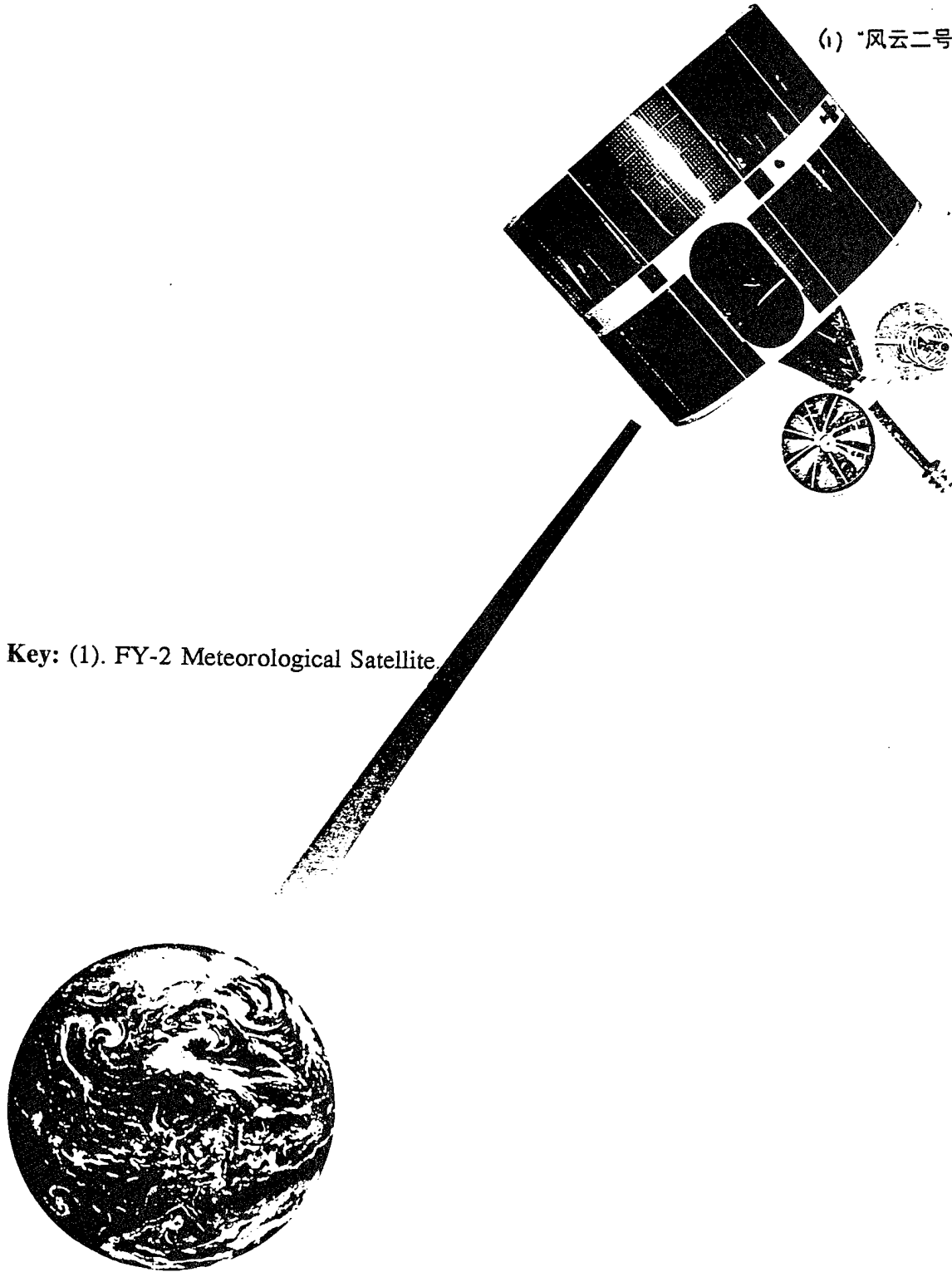

Key: (1). FY-2 Meteorological Satellite.

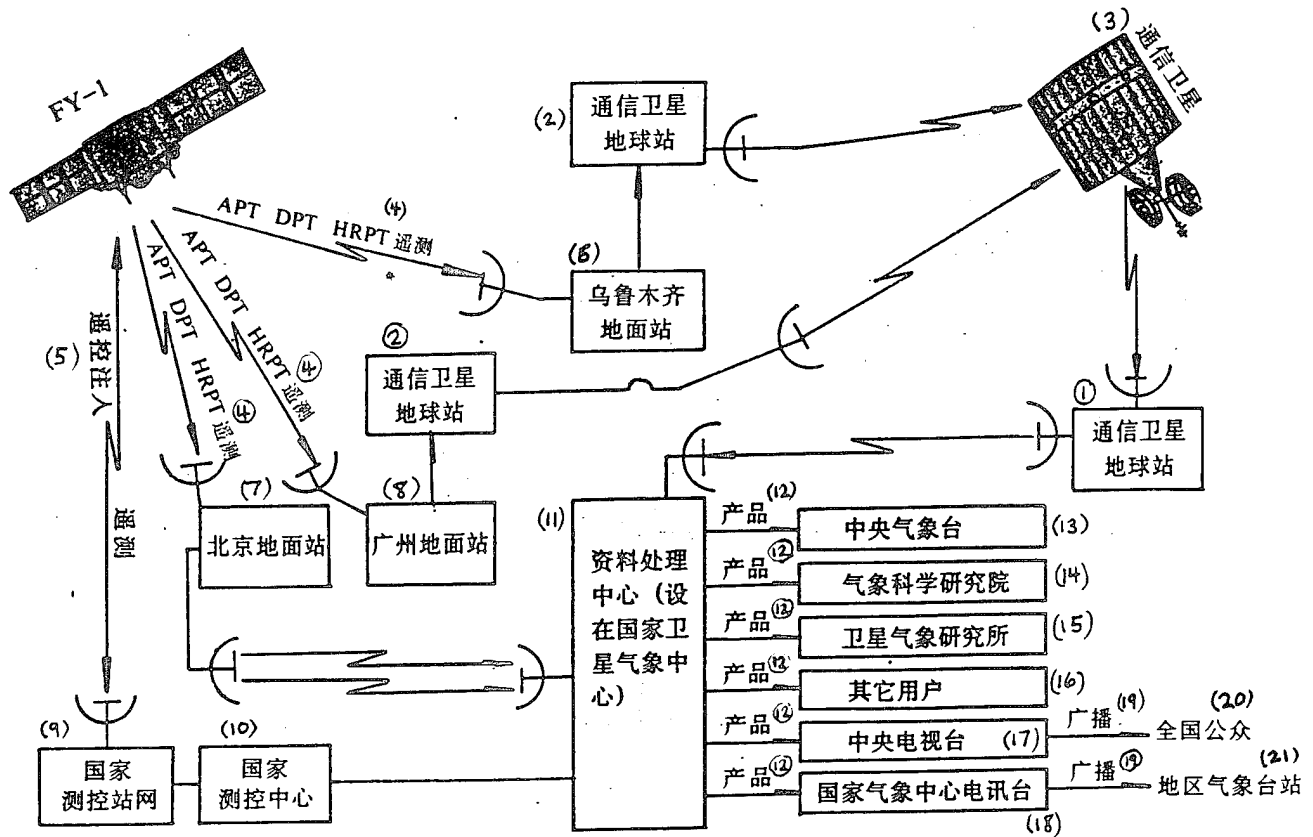

(i) FY-1 系统布局及功能概况

Key: (1). FY-1 Systems Layout and Function Survey. (2). Communications Satellite Earth Station. (3). Communications Satellite. (4). [...] Telemetry. (5). Remote Control Injection. (6). Urumqi Ground Station. (7). Beijing Ground Station. (8). Guangzhou Ground Station. (9). National Telemetry and Remote Control Station Network. (10). National Telemetry and Remote Control Center. (11). Data Processing Center (in the National Satellite Meteorological Center). (12). Product. (13). Central Meteorological Station. (14). Meteorological Science Research Institute. (15). Satellite Meteorological Research Institute. (16). Other Users. (17). Central Television Station. (18). National Meteorological Center Telecommunications Station. (19). Broadcast. (20). National Audience. (21). Regional Meteorological Stations.

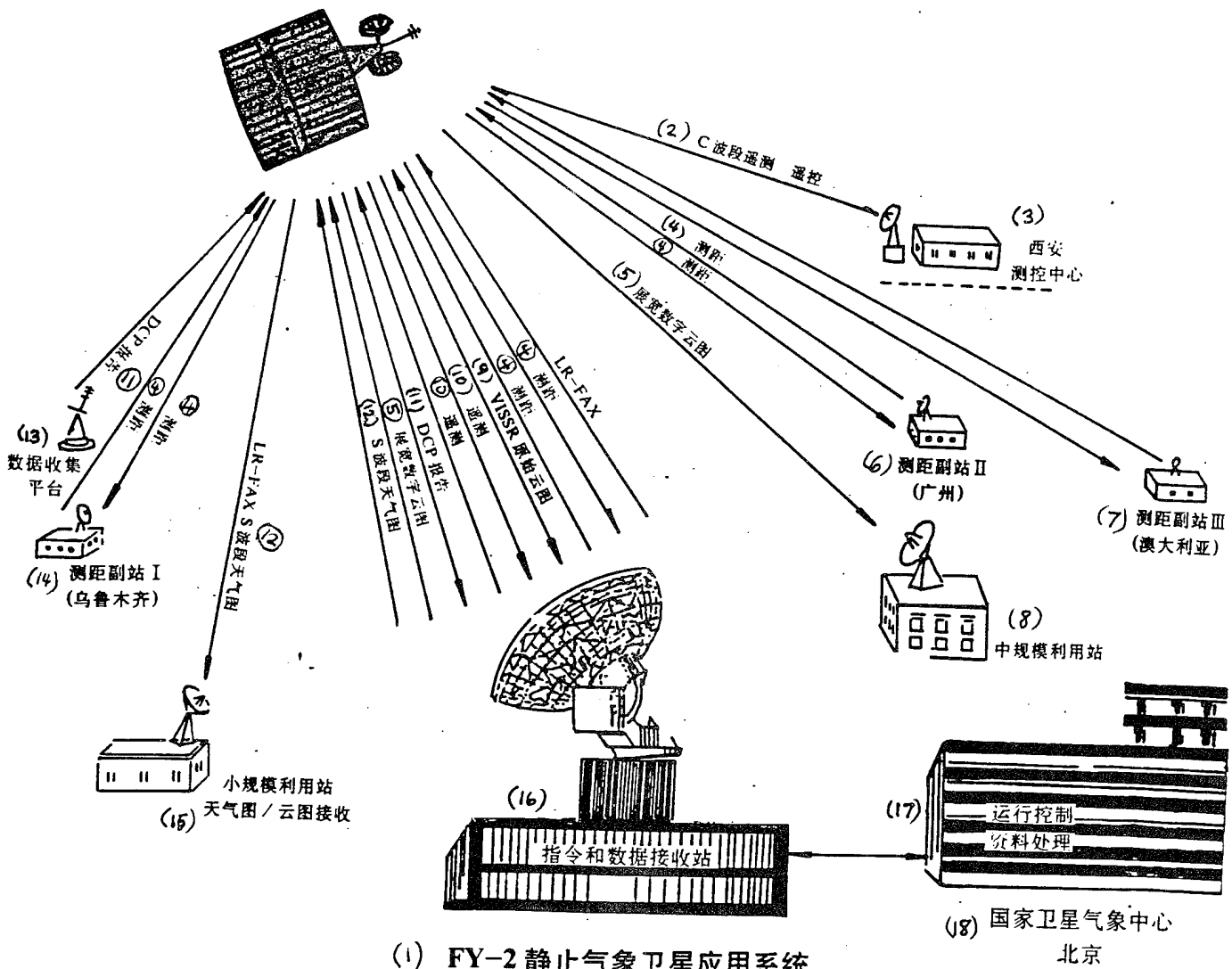

Key: (1). Applied Systems of the FY-2 Geostationary Meteorological Satellite. (2). C-Band Telemetry and Remote Control. (3). Xi'an Telemetry and Remote Control Center. (4). Range Finding. (5). Extended Digital Cloud Chart. (6). Turn Around Ranging Station II (Guangzhou). (7). Turn Around Ranging Station III (Australia). (8). Medium-Scale Data Utilization Station. (9). VISSR Initial Cloud Chart. (10). Telemetry. (11). DCP Report. (12). S-band Weather Chart. (13). Data Collection Platform. (14). Turn Around Ranging Station I (Urumqi). (15).

Small-Scale Data Utilization Station. Weather Map/Cloud Chart Reception. (16). Command and Data Acquisition Station. (17). Operations Control. Data Processing. (18). National Satellite Meteorological Center, Beijing.

Page 10

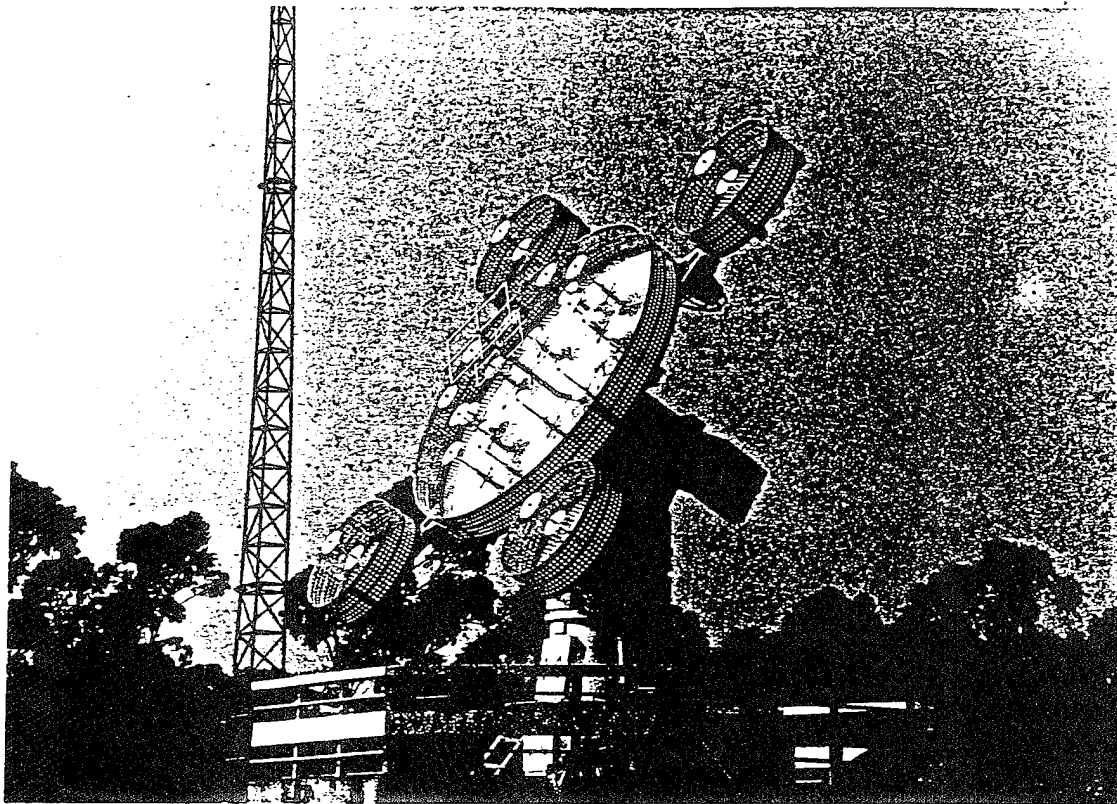

(1) 地面站接收天线

Key: (1). Ground Station Receiving Antenna.

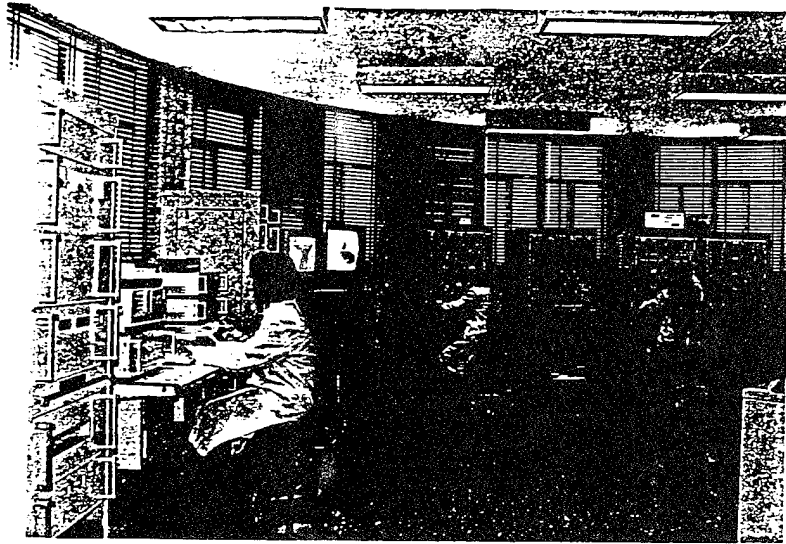

(2)地面站接收机房

**Key:** (2). Ground Station Receiving Room.

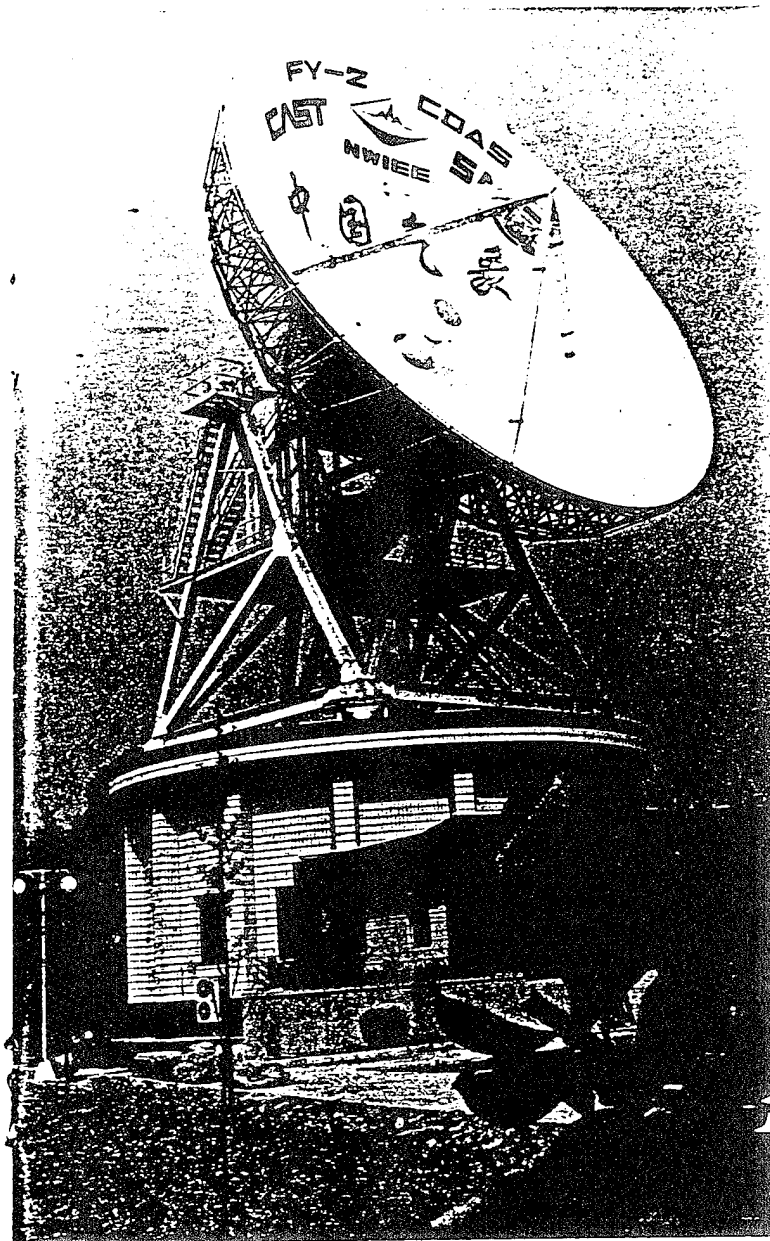

(1) 指令和数据接收站

Key: (1) Command and Data Acquisition Station.

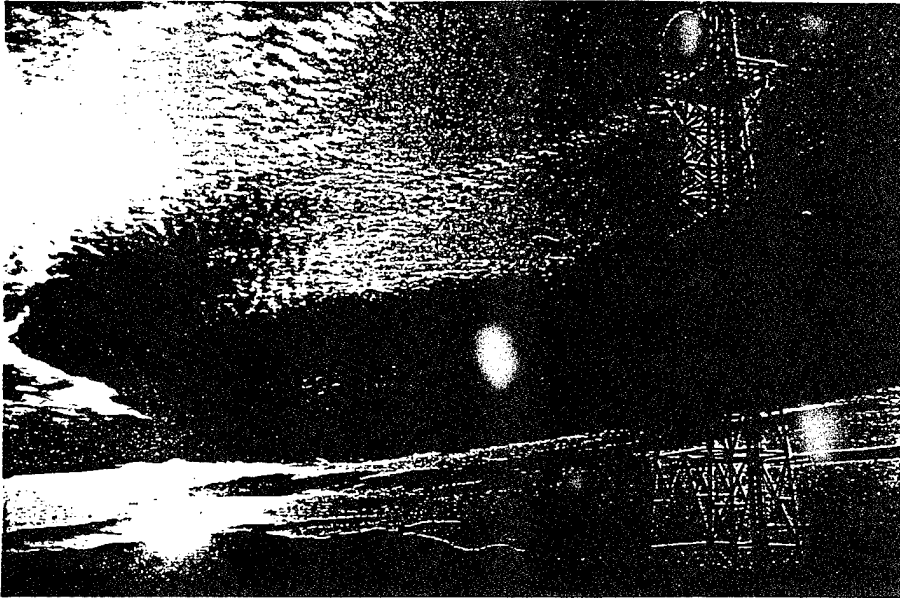

(1) 地面站微波天线

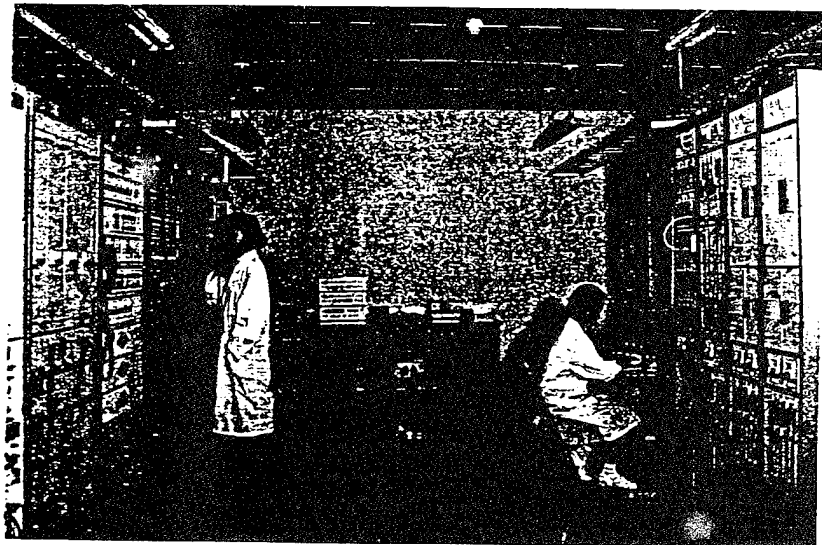

(2) 中心通信机房

Key: (1). Ground Station Microwave Antenna. (2). Central Communications Room.

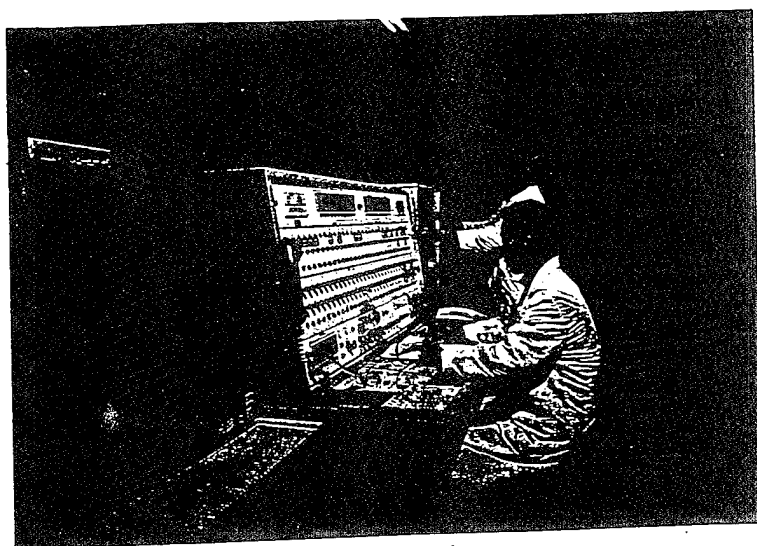

(1) 指挥调度机房

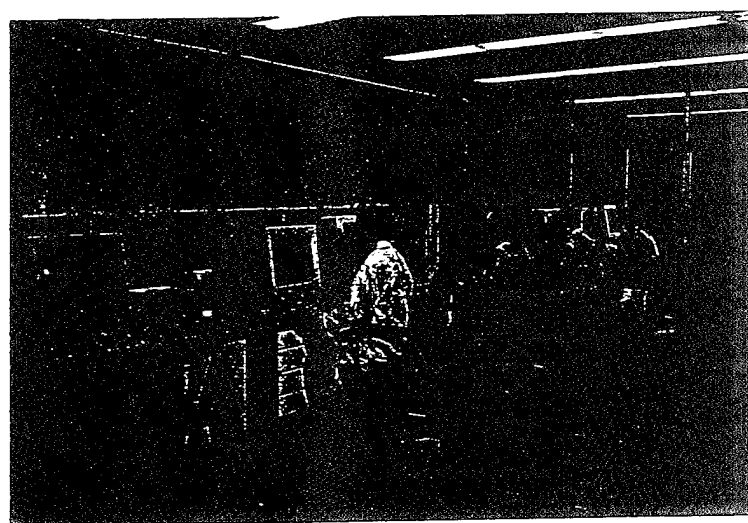

(2) 运行控制机房

Key: (1). Commanding and Scheduling Office. (2). Operational Control Office.

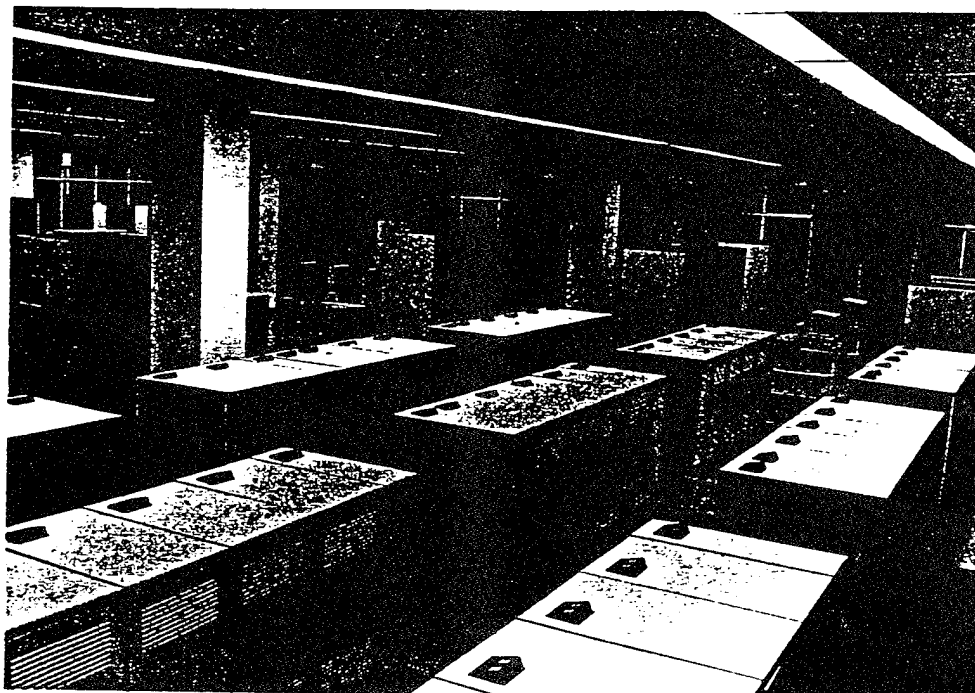

(1) 资料处理中心计算机主机房

Key: (1). Main Computer Room of the Data Processing Center.

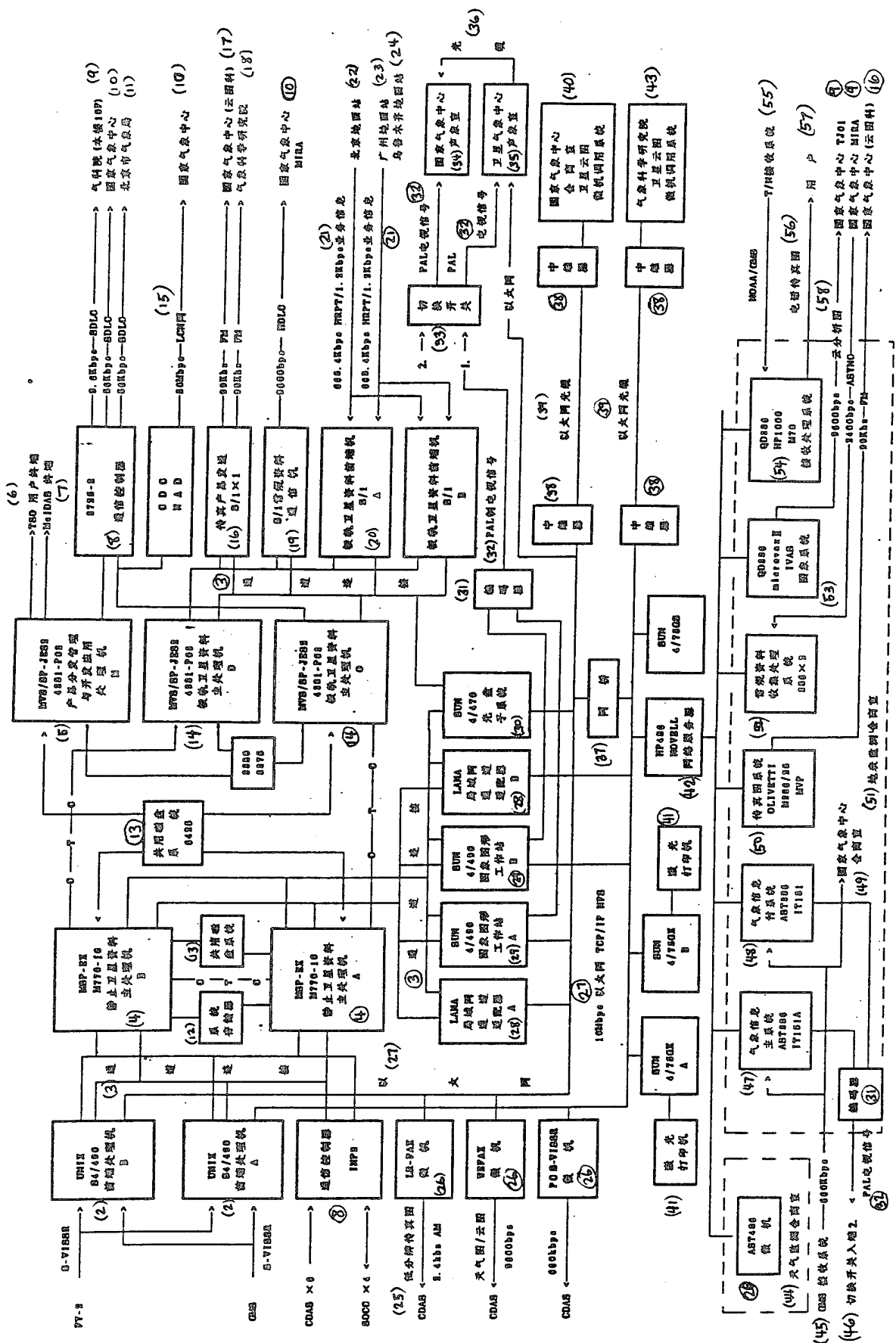

(1) 资料处理中心 (DPC) 计算机系统总体与网络结构示意图

**Key:** (1). Schematic Drawing of the Overall and Network Structures of the Data Processing Center (DPC) Computer System. (2). [...] Front-End Processor [...]. (3). Channel Linking. (4). [...] Main Geostationary Satellite Data Processor [...]. (5). [...] Product Distribution Management and Development Application Processor [...]. (6). TSO User Terminal. (7). MeIDAS Terminal. (8). [...] Communication Controller [...]. (9). Academy of Meteorological Science (Tenth Floor of this Building). (10). National Meteorological Center. (11). Beijing Municipal Meteorological Office. (12). System Memory. (13). Public Magnetic Disk System. (14). [...] Main Polar Orbit Satellite Information Processor [...]. (15). LCN Network. (16). Fax Product Transmission [...]. (17). National Meteorological Center (Cloud Chart Department). (18). Academy of Meteorological Science. (19). S/1 Conventional Data Communication Processor. (20). Polar Orbit Satellite Data Front-End Processor [...]. (21). 665.4 Kbps HRPT/1.2 Kbps Service Information. (22). Beijing Ground Station. (23). Guangzhou Ground Station. (24). Urumqi Ground Station. (25). Low-Resolution Fax. (26). [...] Microcomputer<sup>1</sup>. (27). Ethernet. (28). LANA Local Area Network Channel Adapter [...]. (29). SUN 4/490 Image Work Station [...]. (30). SUN 4/470 Laser Disk System. (31). Encoder. (32). PAL Video Signal. (33). Switchover Switch. (34). National Meteorological Center Acoustic Image Chamber. (35). Satellite Meteorological Center Acoustic Image Chamber. (36). Optical Cable. (37). Network Bridge. (38). Relay. (39). Ethernet Optical Cable. (40). National Meteorological Center Conference Room Cloud Image Microcomputer Transfer System. (41). Laser Printer. (42). [...] Network Server. (43). Academy of Meteorological Science Satellite Cloud Image Microcomputer Transfer System. (44). Weather Monitoring Conference Room. (45). GMS Receiving System. (46). Switchover Switch Entry 2. (47). Main Meteorological Information System [...]. (48). Meteorological Information Subsystem [...]. (49). National Meteorological Center Conference Room. (50). Fax Image System [...]. (51). Earth Surface Monitoring Conference Room. (52). Conventional Data Collection and Processing System [...]. (53). [...] Imaging System. (54). [...] Receiving and Processing System. (55). T/N Receiving System. (56). Telephone Fax Image. (57). User. (58). Cloud Analysis Chart.

---

<sup>1</sup> Best guess for *weiji*, "micro machine."

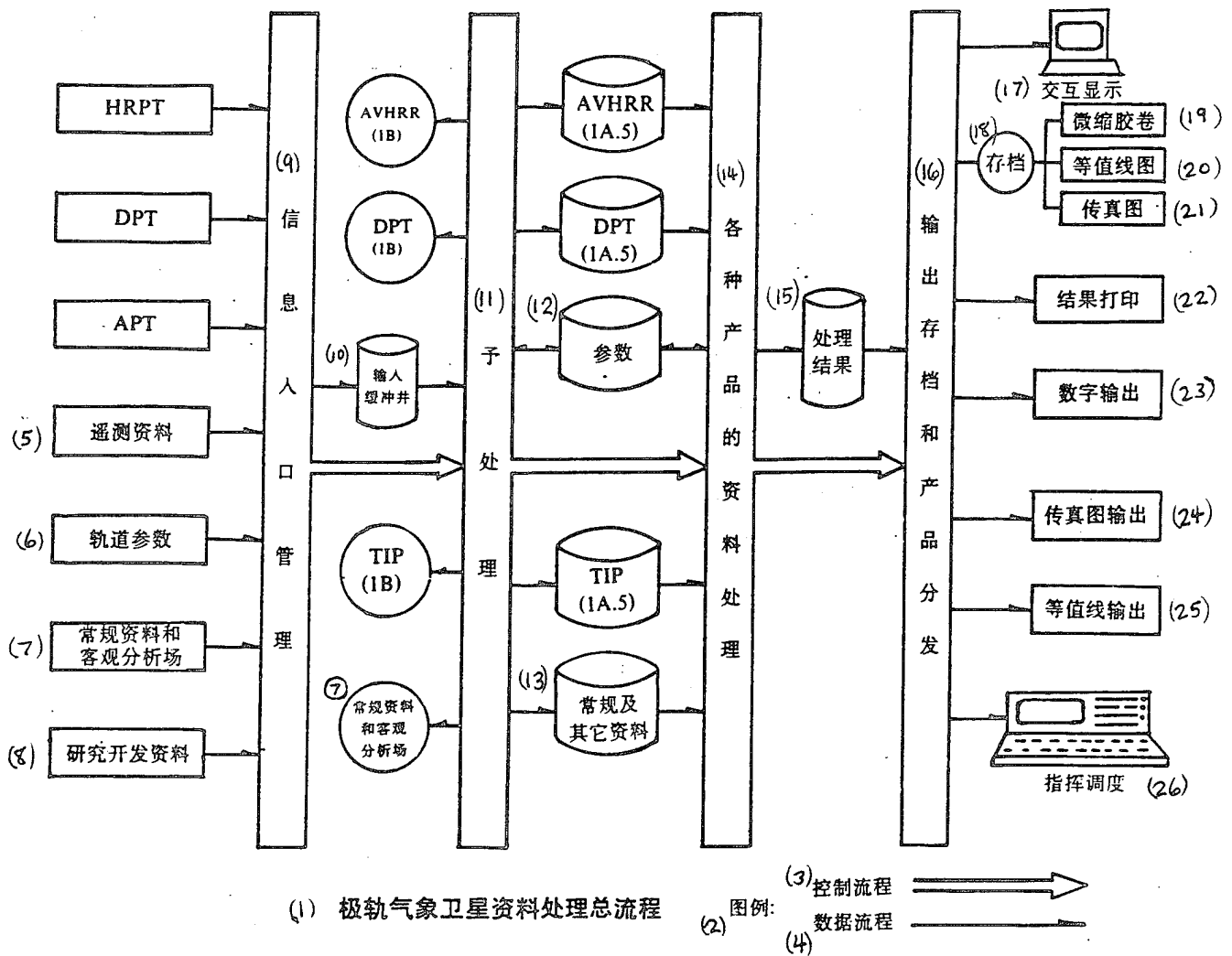

Key: (1). Polar Meteorological Satellite Data Processing Flow Chart. (2). Key. (3). Control Flow. (4). Data Flow. (5). Telemetry Data. (6). Orbit Parameters. (7). Conventional Data and Subjective Analysis Field. (8). Research and Development Data. (9). Information Entry Management. (10). Input Buffer Well. (11). For Processing. (12). Parameters. (13). Conventional and Other Data. (14). Data Processing of Products. (15). Results of Processing. (16). Output Files and Product Distribution. (17). Interactive Display. (18). Files. (19). Microfilm. (20). Contour Line Image. (21). Fax Image. (22). Printing of Results. (23). Digital Output. (24). Fax Image Output. (25). Contour Line Output. (26). Command Scheduling.

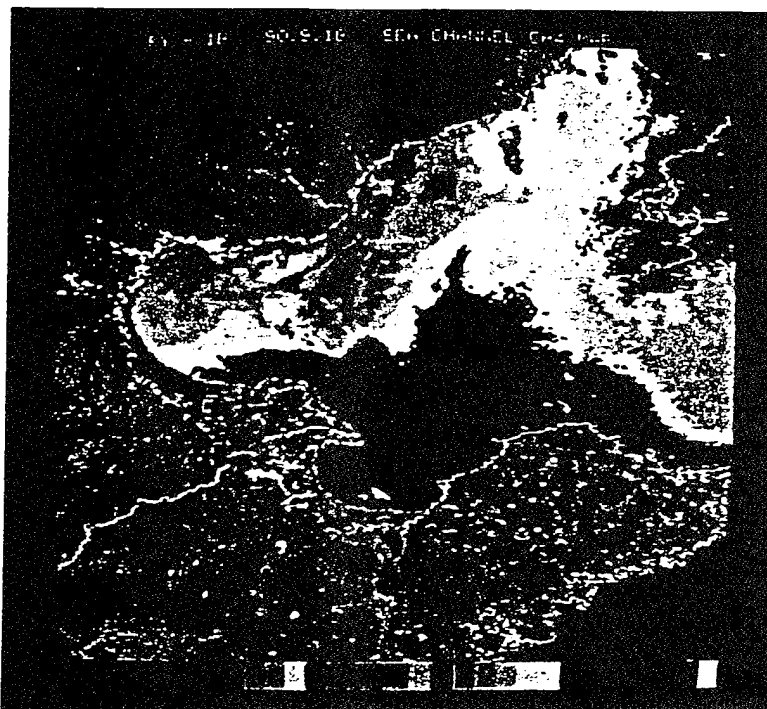

(1) 海色图

**Key:** (1). Sea Color Map.

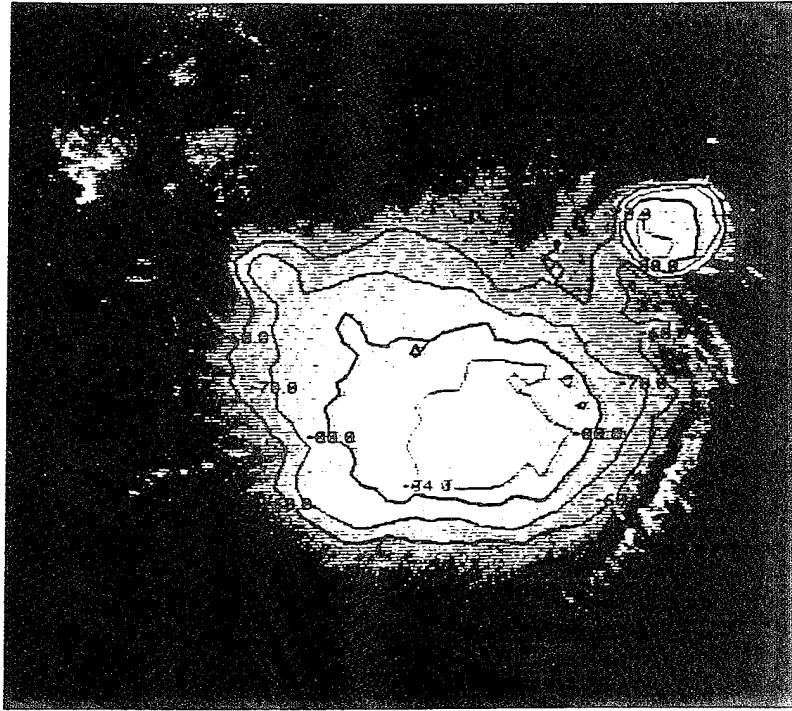

(2) 中尺度对流复合体

Key: (2). Medium-scale Convection Complex.

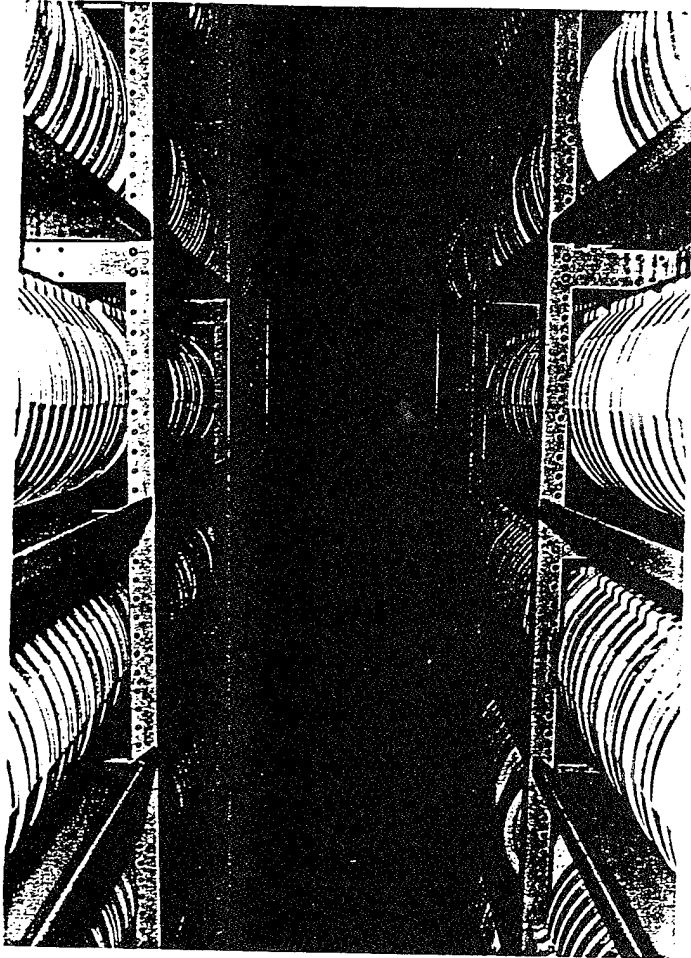

(1) 磁带库一角

Key: (1) One Corner of the Tape Archives.

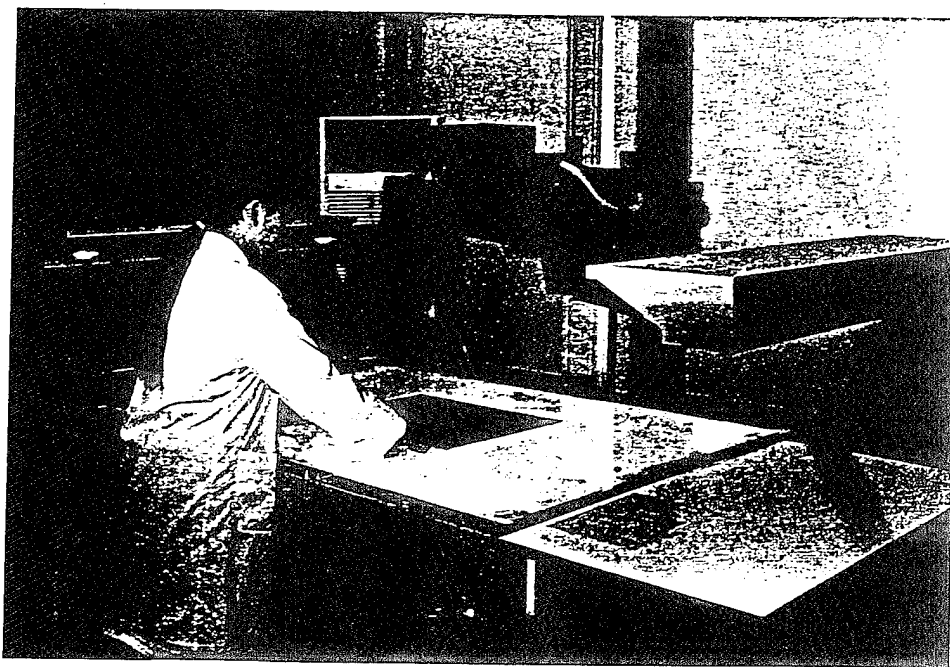

(2)  
图片缩微

Key: (2). Image Reduction.

(1) “风云一号”气象卫星资料接收处理系统产品表

	(2) 产品种类	(3) 空间分辨率	(4) 覆盖范围	(5) 输出时间(分) (所在轨道卫星出境后)	(6) 输出时次(次/日)
(7)	HRPT 1A · 5(1B)数据集	1Km	(25) 中国及周边地区	20	21
(7)	DPT 1A · 5(1B)数据集	4Km	(26) 全球任意地区	20	6
(8)	单轨展宽云图	1Km	(27) 单轨探测区	45	21
(9)	DPT 单轨图	4Km	(27) 单轨探测区	45	6
(10)	极射赤道投影拼图	3.7~7.4Km	(25) 中国及周边地区	60	4
(11)	麦卡托投影拼图	5.7Km	40° N~40° S, 20° E~180° E	60	1
(12)	局地增强图	1.1~4Km	(28) 根据需要	40	(28) 根据需要
(13)	局地多光谱迭加云图	1.1~4Km	(28) 根据需要	40	(28) 根据需要
(14)	云参数	50Km	(25) 中国及周边地区	60	(32) 4次/日, 旬, 月
(15)	海面温度分布	50Km	(29) 中国沿海区域	60	(32) 1次/日, 旬, 月
		<10Km	(30) 局地	60	1
(16)	射出长波辐射	50Km	(25) 中国及周边地区	60	(32) 4次/日, 旬, 月
(17)	大气温度分层分布	70~80Km	(25) 中国及周边地区	60	(32) 4次/日, 旬, 月
(18)	大气湿度分层分布	70~80Km	(29) 中国及周边地区	60	(32) 4次/日, 旬, 月
(19)	大气臭氧总含量	70~80Km	(25) 中国及周边地区	60	(32) 4次/日, 旬, 月
(20)	云分析图		(25) 中国及周边地区		1~2
(21)	植被指数	1Km	(31) 中国地区	120	1
(22)	积雪范围	4Km	(31) 中国地区	120	(33) 1次/日, 旬
(23)	海冰范围	4Km	(29) 中国沿海区域	120	(33) 1次/日, 旬
(24)	其它专业产品		(28) 根据需要		

Key: (1). Product Chart of the FY-1 Meteorological Satellite Data Receiving and Processing System. (2). Type of Product. (3). Space Resolution. (4). Range of Coverage. (5). Output Time (Minutes) (After the Orbiting Satellite Leaves the Area [of Coverage]) (6). Frequency of Output (Times per Day). (7). [...] Data Collection. (8). Single Orbit Extended Cloud Chart. (9). [...] Single Orbit Chart. (10). Polar-Equatorial Projection Composite Map. (11). Mercator Projection Composite Map. (12). Local Enhancement Map. (13). Local Multiple-Spectrum Superimposed Cloud Map. (14). Cloud Parameters. (15). Sea Surface Temperature Distribution. (16). Emitted Long Wave Radiation. (17). Atmospheric Temperature Layer Distribution. (18). Atmospheric Humidity Layer Distribution. (19). Atmospheric Ozone Content. (20). Cloud Analysis Map. (21). Vegetation Cover Index. (22). Range of Snow Accumulation. (23). Seawater Range. (24). Other Specialized Products. (25). China and Peripheral Regions. (26). Anywhere in the World. (27). Single-Orbit Detection Area. (28). As Needed. (29). China's Coastal Regions. (30). Local. (31). China. (32). [...] Time(s) per Day, Ten Days, or Month. (33). Once per Day or Ten Days.

(1) “风云二号”气象卫星资料接收处理系统产品表

(2) 表 1 图像产品

(3)	产品名称	(4) 空间分辨率	(5) 覆盖范围	(6) 时延 (分钟)	(7) 输出时次 (次/日)
(8)	展宽数字图像	(16) 可见光 1.25 公里 红外 5 公里	(19) 圆盘	(25) 准实时	24
(9)	水汽图像	(17) 5.0 公里	(20) 部分		24
(10)	局部放大图	(17) 5.0 公里	1/4 圆盘和 (21) 中国地区	10	8
(11)	兰勃托投影图	(17) 10 公里	(22) 亚洲、 太平洋地区	30	24
(12)	麦卡托投影图	(17) 10 公里	45° N-45° S 45° E-165° E	60	4
(13)	低分辨率 传真图像	(17) 10 公里	(23) 1/4 圆盘	5	8
(14)	云分析图	(17) 10 公里	(22) 亚洲、 太平洋地区	60	4
(15)	临时观测图	(18) 同展宽图	(24) 按需要	60	(24) 按需要

Key: (1). Tables of Products from the FY-2 Meteorological Satellite Data Receiving and Processing System. (2). Table 1: Imaging Products. (3). Name of Product. (4). Space Resolution. (5). Range of Coverage. (6). Time Delay (in Minutes). (7). Output Frequency (Times per Day). (8). Expanded Digital Images. (9). Water Vapor Images. (10). Partial Enlarged Images. (11). Lambert Projection Maps. (12). Mercator Projection Maps. (13). Low-Resolution Fax Images. (14). Cloud Analysis Images. (15). Temporary Observation Images.

(16). Visible Light – 1.25 Kilometers; Infrared – 5 Kilometers. (17). [...] Kilometers. (18). Identical Expansion Images. (19). Circular Area. (20). Partial. (21). Quarter-Circle [or -Disk] and China. (22). Asia-Pacific Region. (23). Quarter-Circle. (25). As Needed. (26). Exact Real Time.

(1) 表 2 气象参数产品

(2)	产品名称	(3) 空间 分辨率	(4) 覆盖范围	(5) 时延 (分钟)	(6) 输出时次 (次/日)
(7)	风矢量	50 公里 (12)	50° N-50° S 55° E-155° E	60	4
(8)	云参数分布图	(12) 50 公里	(13) 同上	60	8
(9)	洋面温度	50 公里 (12) 10 公里	50° N-50° S 55° E-155° E (14) 区域可选	60	2
(10)	水汽总含量图	(12) 50 公里	50° N-50° S 55° E-155° E	60	2
(11)	射出长波辐射	(12) 50 公里	(13) 同上	60	8

Key: (1). Table 2: Meteorological Parameter Products. (2). Name of Product. (3). Space Resolution. (4). Range of Coverage. (5). Time Delay (in Minutes). (6). Output Frequency (Times per Day). (7). Wind Vector. (8). Cloud Parameter Distribution Chart. (9). Ocean Surface Temperature. (10). Water Vapor Content Chart. (11). Output Long Wave Radiation. (12). [...] Kilometers. (13). As Above. (14). Region May Be Selected.

### 科学研究工作

卫星气象科学研究工作是卫星气象事业发展的基础。我国卫星气象事业的发展过程，自始至终伴随着大量的科学研究，科研成果推动着卫星气象事业的发展。国家卫星气象中心多年来坚持科研为工程和业务建设服务的指导方针，将科研成果广泛应用到工程建设和业务建设中。

国家卫星气象中心已初步建立了太阳光谱、地物波谱和大气吸收模拟实验室，并开展了相应的应用基础理论研究，为业务和工程的发展提供理论和技术依据。研究气象卫星遥感和反演理论，改进地表和大气参数反演精度。各类图像处理技术和卫星轨道预报方法的研究，使图像定位更加准确、直观、形象。气象卫星在台风、暴雨等大害性天气分析和预报方法的应用研究，以及数值资料对数值预报模式的影响研究，进一步推动了卫星资料的应用。

近年来，结合全球气候变化研究，进一步开展气溶胶参数的提取和分析方法的研究。此外，国家卫星气象中心还参与了我国气象卫星系列发展规划、技术、系统总体建设的研究与设计工作，以及气象、环境卫星科技情报的研究等工作。

### Scientific Research

The scientific research of satellite meteorology is very important for the development of satellite meteorology. As in the other countries, the development of China's satellite meteorology is accompanied with large amount of research work from the beginning, the gained results of these researches have greatly improved the development of the operational work. With the policy of letting scientific research serving the operational work and satellite engineering, the Satellite Meteorological Center applies research results extensively into its operational work and satellite engineering.

Now the labs of solar spectrum, radiative spectrum and simulating atmospheric absorption have been set up in the Satellite Meteorological Center for supporting the operational and engineering tasks. The needed theoretical and technical studies are carried out. The theoretical studies include satellite remote sensing and the data retrieval accuracy, the retrieval accuracy of atmospheric parameter, the retrieval of image processing technique and satellite orbit prediction method for the better satellite image location; the studies on satellite data application in the severe weather analysis and forecast such as typhoon and rainstorm etc. The study on the impact of digital data on numerical weather forecast model. These studies and researches have played an important role in popularizing the application of satellite data in China.

In the study of global climate change, the Satellite Meteorological Center has carried out further study on the extraction and analysis of atmospheric parameter extraction and

的研究和推广应用。不同规模气象...  
微机处理系统的研制成功和推广，大大增强了基层站的天气监测和预报能力。



(1) 太阳光谱观测

Key: (1). Solar Spectrum Observation.

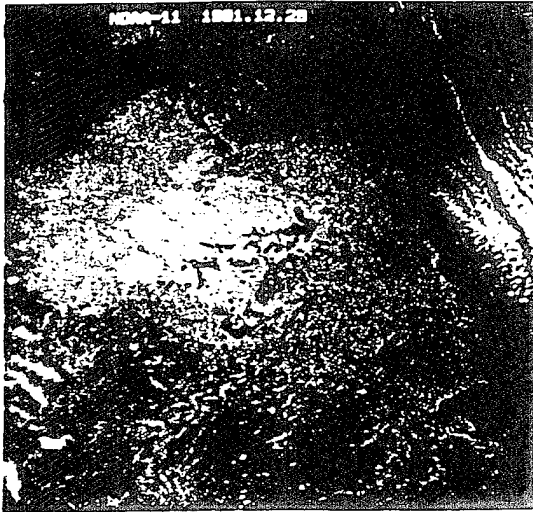

(1) 江淮大雪 (1991年12月29日)

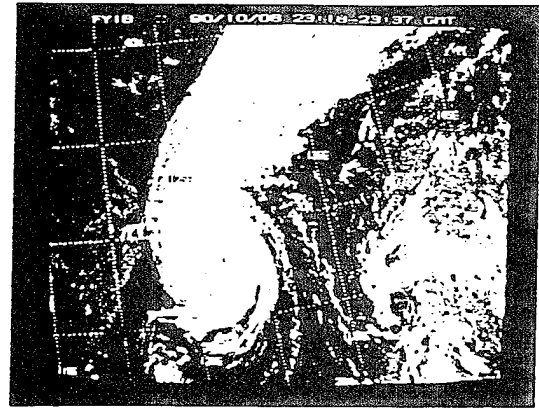

(3) 1990年第22号台风单轨展宽云图

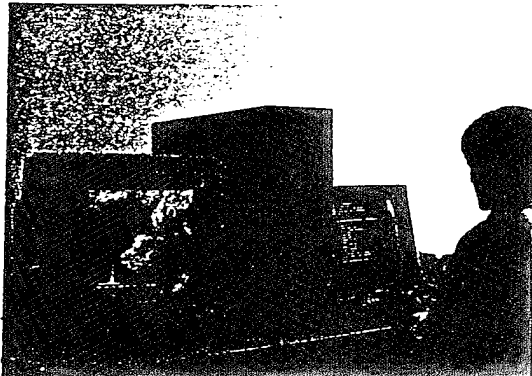

(2) 系统配置

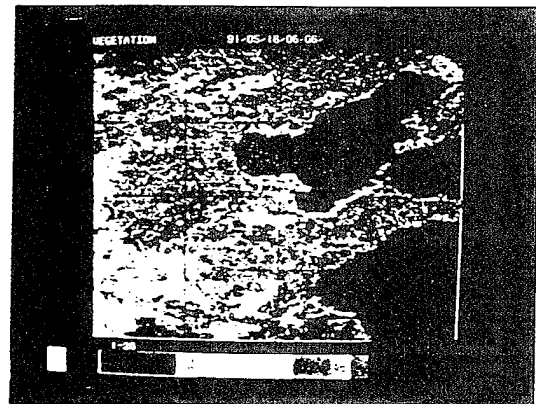

(4) 华北及山东半岛植被图 (1991年5月16日).

Key: (1). Heavy Snow in the Yangtze and Huaihe River Region (December 29, 1991). (2). System Configuration. (3). Extended Cloud Map of Typhoon No. 22, 1991. (4). Vegetation Map of North China and the Shandong Peninsula (May 16, 1991).

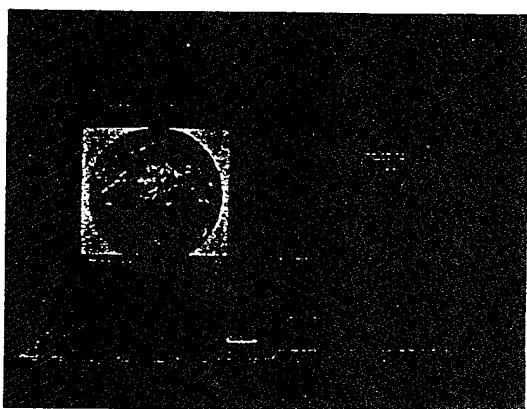

(1) 系统配置

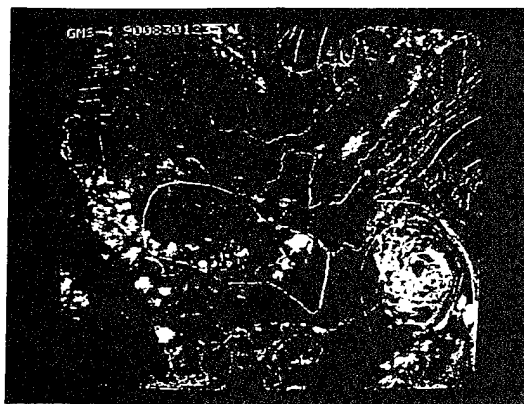

(3) 卫星资料与常规资料等值线叠加图

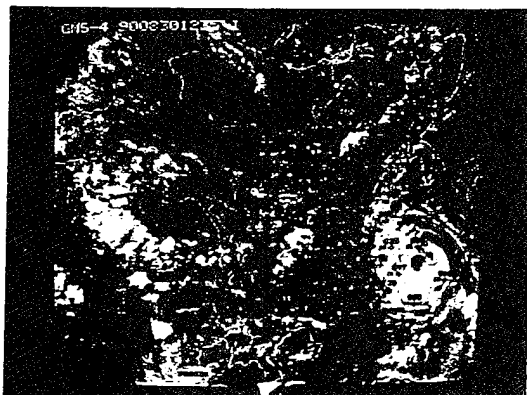

(2) 卫星资料与常规资料要素场叠加图

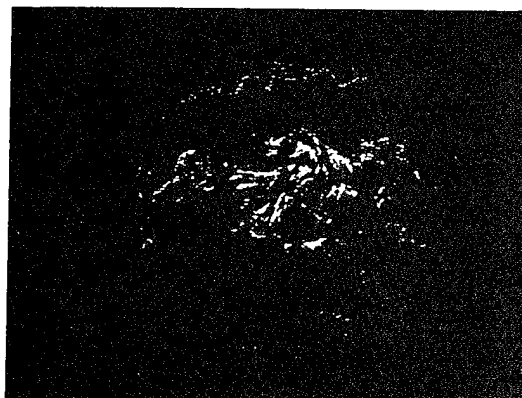

(4) GMS<sub>4</sub> 全圆盘可见光云图

**Key:** (1). System Configuration. (2). Map of Conventional Data Feature Field Superimposed over Satellite Data. (3). Map of Conventional Contour Line Data Superimposed over Satellite Data. (4). GMS<sub>4</sub> Full-Circle Visible Light Cloud Map.

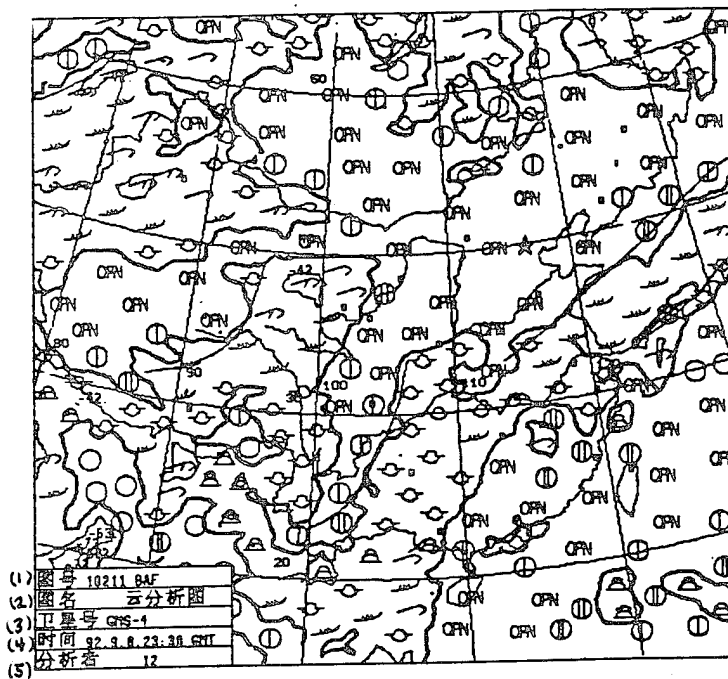

(6) 1992年9月6日的云分析图

Key: (1). Map Number. (2). Map Name: Cloud Analysis Map. (3). Satellite Number [...] (4). Time: [...]. (5). Analyst: [...]. (6). Cloud Analysis Map for September 6, 1992.

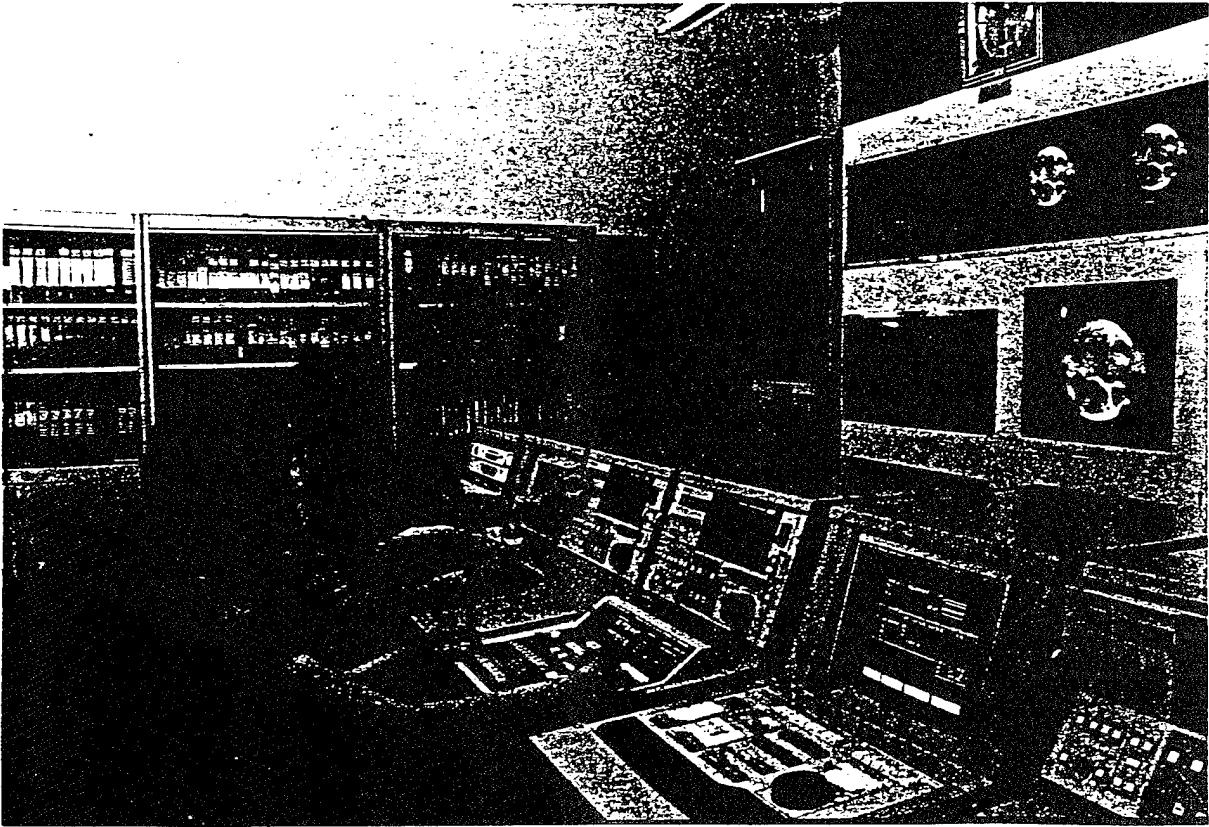

(7) 《气象信息》  
节目制作

Key: (7). "Meteorological Information" [Television] Program Production.

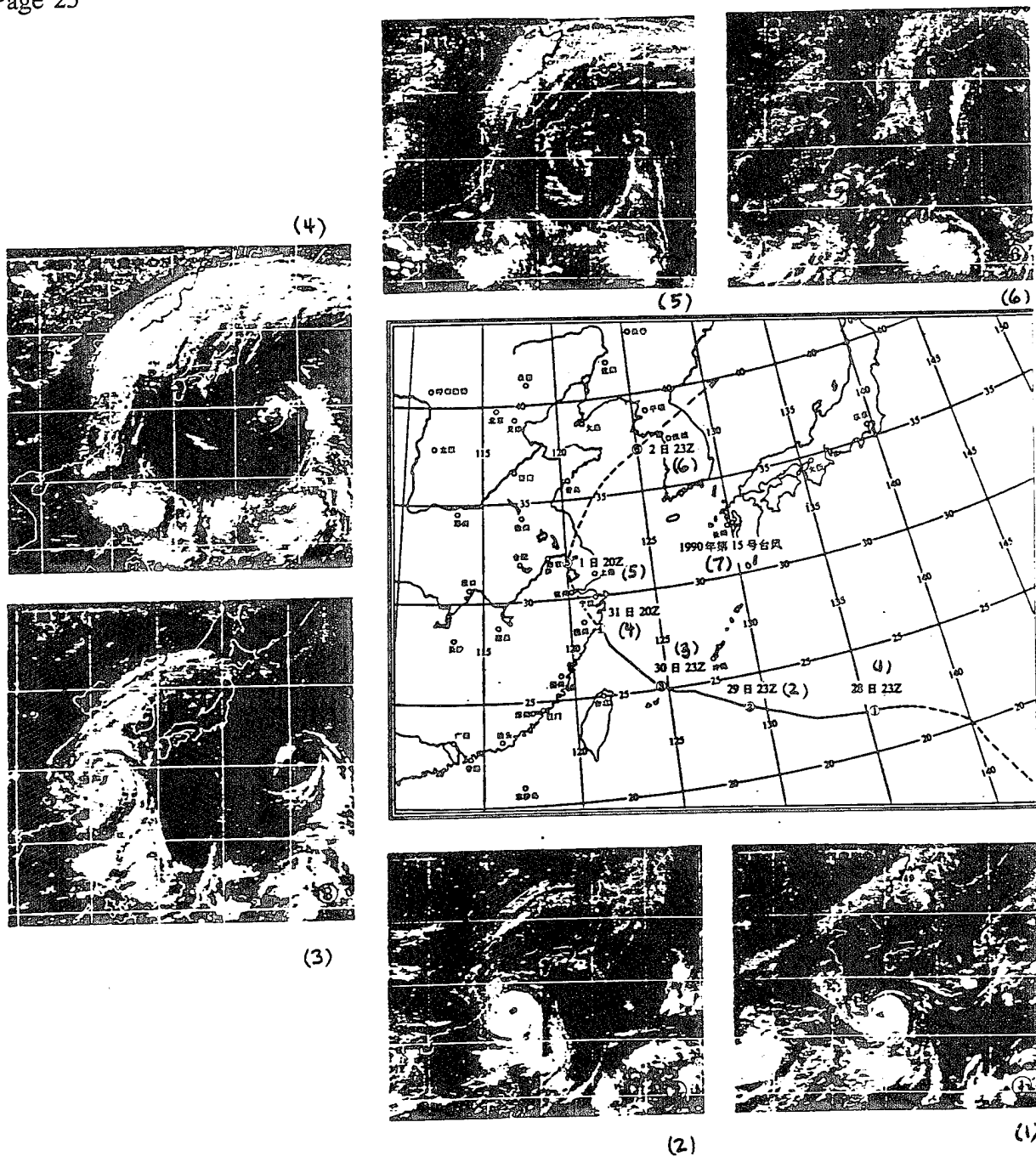

Key: (1). The 28th [of the month] 23Z. (2). The 29th 23Z. (3). The 30th 23Z. (4). The 31st 20Z. (5). The 1st 20Z. (6). The 2nd 23Z. (7). Typhoon No. 15, 1990.  
 Note: Numbers on map correspond to satellite image numbers.

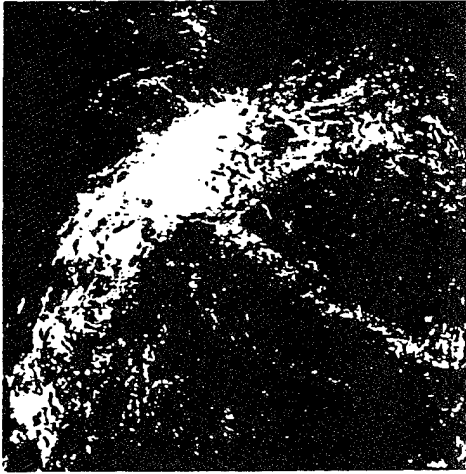

(1) 涌入我国青藏高原西部的低压云系  
(1988年9月25日)



(2) 孟加拉湾和北印度洋上的西南季风云系可见光延时云图 (1988年9月28日)

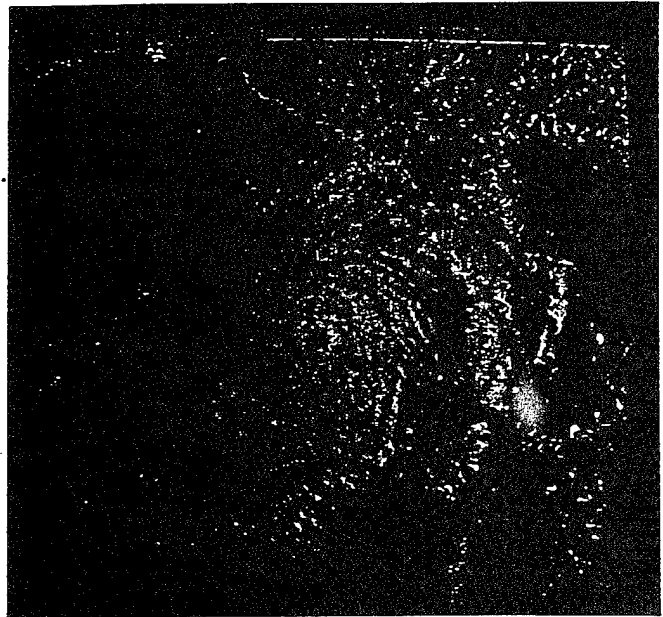

(3) 孟加拉湾热带风暴 (1991年4月29日)

Key: (1). Low-Pressure Cloud System Entering the Qinghai-Xizang [Tibetan] Plateau from the West (September 25, 1988). (2). Visible Light Time-Delay Image of Southwestern Monsoon Cloud System over the Bay of Bengal and the Northern Indian Ocean (September 28, 1988). (3). Tropical Storm in the Bay of Bengal (April 29, 1991).

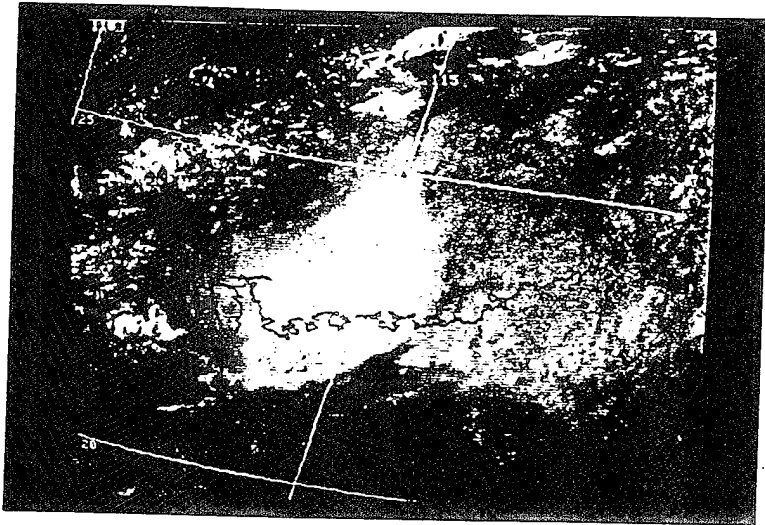

(1) 华南暴雨云团

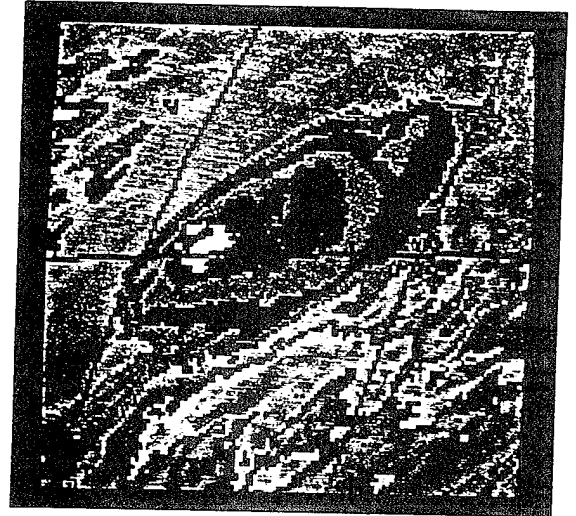

(2) 西南低涡

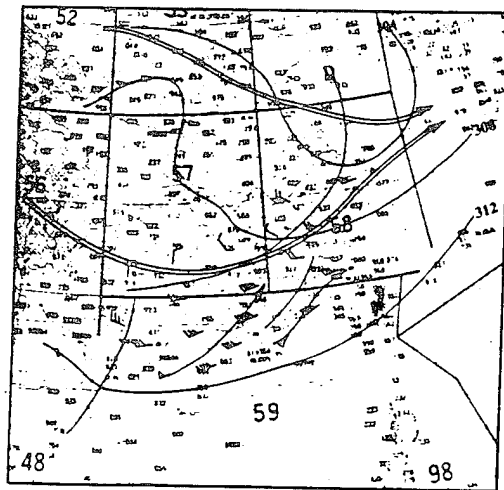

(3) 1987年5月22日天气形势图  
单矢量线 700Hpa 急流位置 双矢量线 200Hpa 急流位置

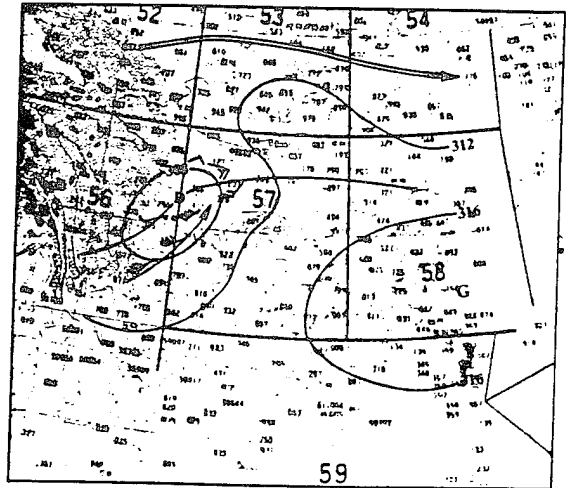

(4) 1989年7月9日1200GMT天气形势图  
单矢量线: 700Hpa 急流位置 双矢量线: 300Hpa 急流位置

Key: (1). Rainstorm Cloud Cluster over South China. (2). Low Vortex in the Southwest. (3). Weather Form Map, May 22, 1987. Single Vector Line: 700 Hpa Jet Stream Position. Double Vector Line: 200 Hpa Jet Stream Position. (4). Weather Form Map, July 9, 1989, at 1200 GMT. Single Vector Line: 700 Hpa Jet Stream Position. Double Vector Line: 300 Hpa Jet Stream Position.

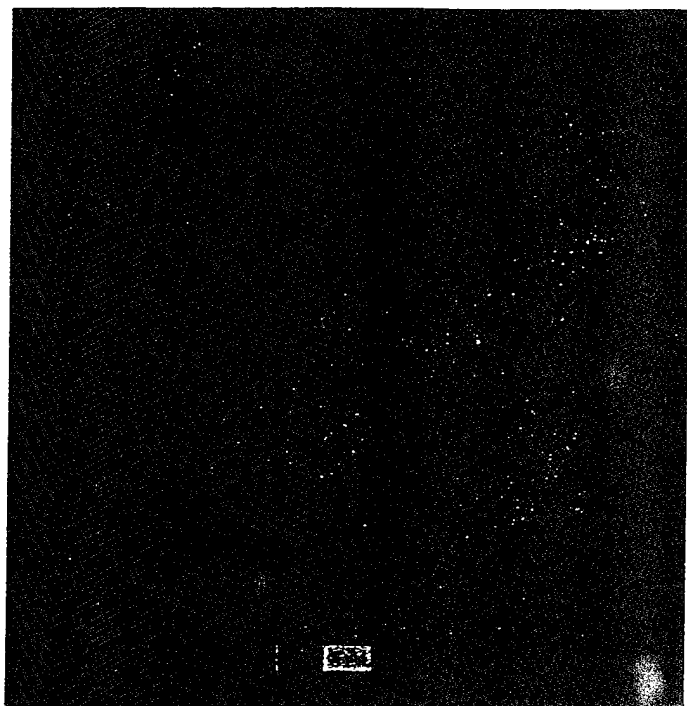

(1) 全国植被图



(2) 大兴安岭森林火灾图像 (1987年5月7日)

**Key:** (1). Vegetation Map of China. (2). Image of a Forest Fire in the Greater Xing'an Mountains (May 7, 1987).



(3) 江淮地区洪水灾害图像 (1991年7月19日)

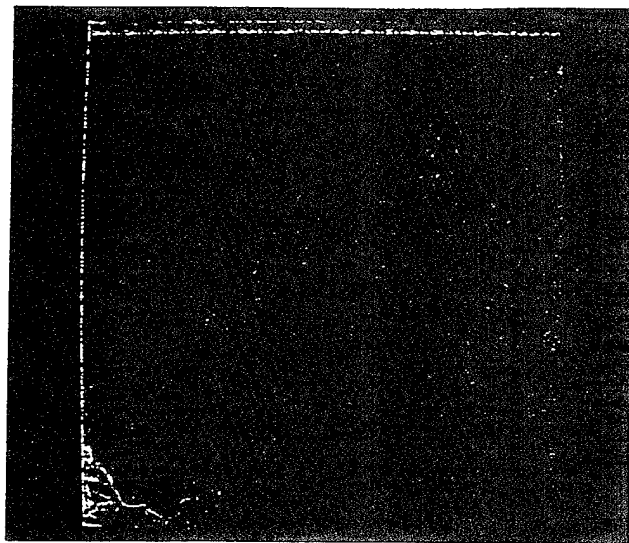

(4) 灾前的气象卫星遥感图像 (1991年5月16日)

Key: (3). Image of a Flood in the Yangtze and Huaihe River Region (July 19, 1991). (4). Satellite Remote-Sensing Image [of the Same Region] Before the Flood (May 16, 1991).



(1) 巴丹吉林沙漠

**Key:** (1). Badain Jaran Desert [in Inner Mongolia].

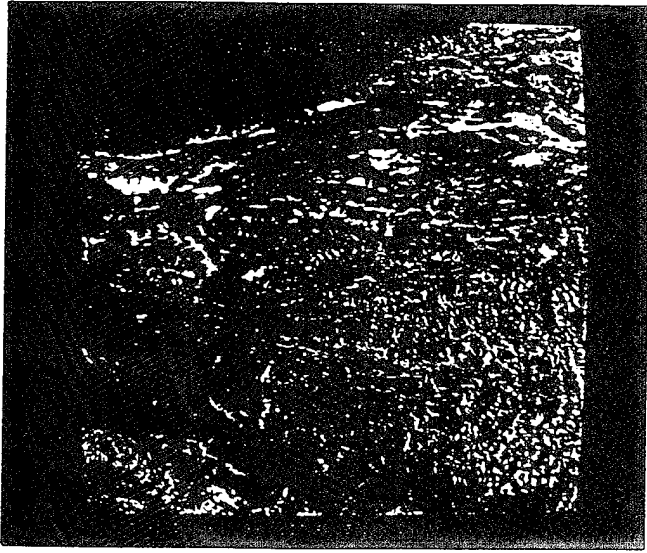

(2) 青藏高原地貌

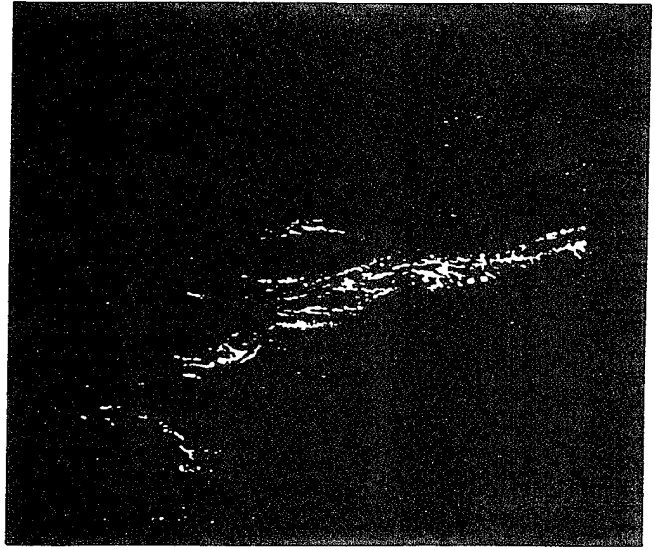

(3) 天山及其附近地表特征

Key: (2). Landforms of the Tibetan Plateau. (3). Tianshan Mountain and Neighboring Surface Features.

Page 30

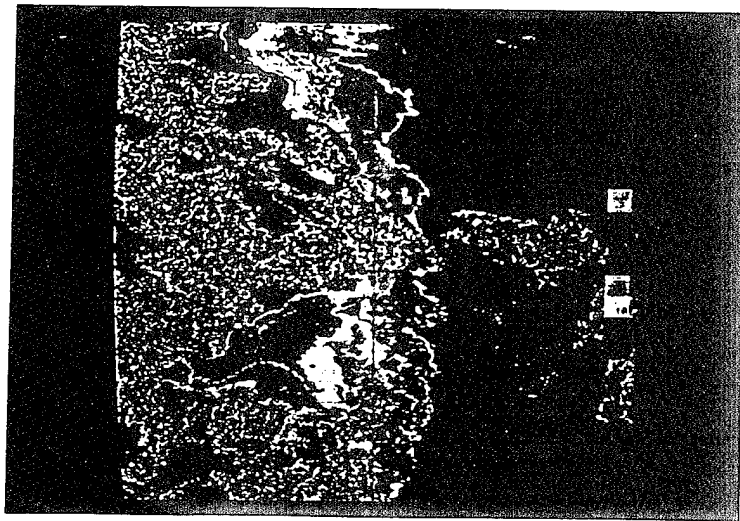

(1) 中国沿海悬浮泥沙浓度分布情况 (1988年8月2日)

Key: (1). Silt Density Distribution in China's Coastal Region (August 2, 1988).



(2) 海温



(3) 辽东湾海冰分布 (1990年1月31日)

Key: (2). Sea Surface Temperature. (3). Liaodong Bay Seawater Distribution (January 31, 1990).

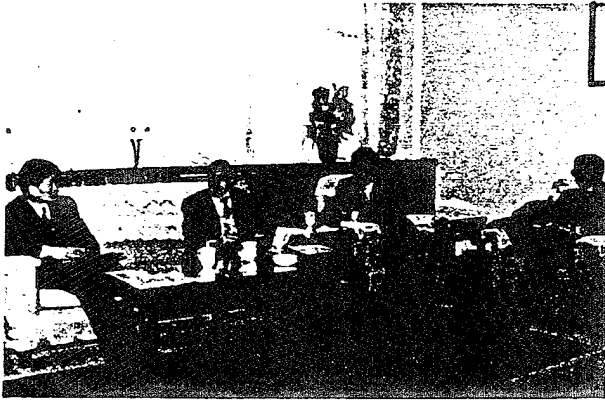

(1) 洽谈

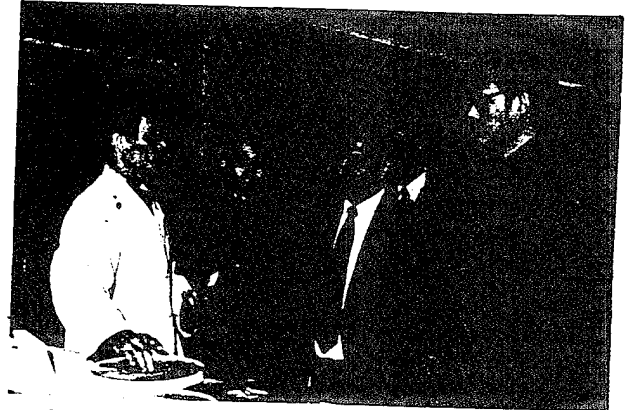

(3) 参观

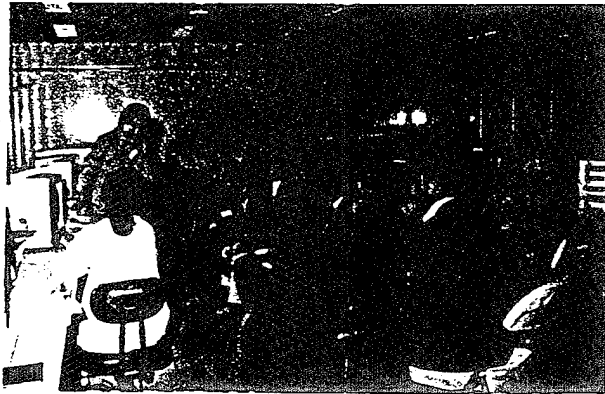

(2) 讲学

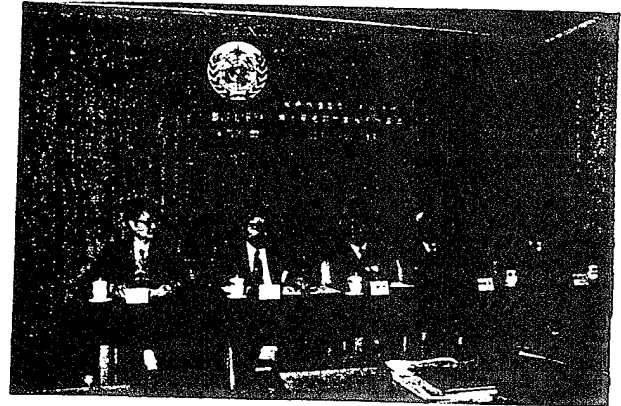

(4) WMO 卫星气象培训班

Key: (1). Holding a Discussion. (2). A Lecture. (3). International Experts Pay a Visit. (4). WMO Satellite Meteorology Training Class.

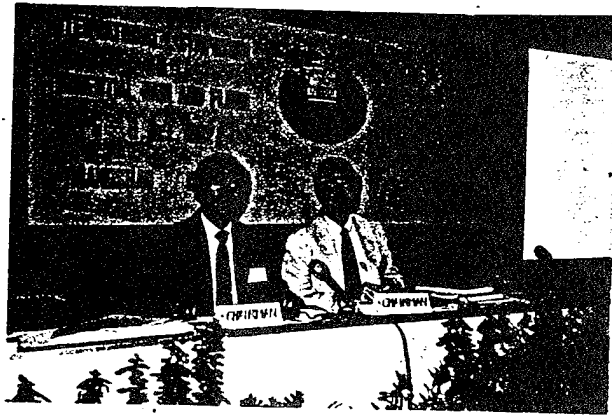

(5) 出席国际会议

Key: (5). Attending an International Conference.

DISTRIBUTION LIST

DISTRIBUTION DIRECT TO RECIPIENT

ORGANIZATION	MICROFICHE
B085 DIA/RTS-2FI	1
C509 BALLOC509 BALLISTIC RES LAB	1
C510 R&T LABS/AVEADCOM	1
C513 ARRADCOM	1
C535 AVRADCOM/TSARCOM	1
C539 TRASANA	1
Q592 FSTC	4
Q619 MSIC REDSTONE	1
Q008 NTIC	1
Q043 AFMIC-IS	1
E404 AEDC/DOF	1
E410 AFDTC/IN	1
E429 SD/IND	1
P005 DOE/ISA/DDI	1
1051 AFIT/LDE	1
PO90 NSA/CDB	1

Microfiche Nbr: FTD96C000060  
NAIC-ID(RS)T-0659-95