

# NATIONAL AIR INTELLIGENCE CENTER



REFLECTORS FOR HIGH-POWERED CO<sub>2</sub> LASERS

by

Li Xiaoping, Zhou Fengqing, et al.

2025 QUALITY INSPECTED



INFO COLLECTED

Approved for public release:  
distribution unlimited

19960409 002

**HUMAN TRANSLATION**

NAIC-ID(RS)T-0006-96 21 March 1996

MICROFICHE NR: 46C000261

REFLECTORS FOR HIGH-POWERED CO<sub>2</sub> LASERS

By: Li Xiaoping, Zhou Fengqing, et al.

English pages: 9

Source: Laser Technology, Vol. 19, Nr. 2, April 1995;  
pp. 70-73

Country of origin: China

Translated by: Leo Kanner Associates  
F33657-88-D-2188

Requester: NAIC/TATD/Bruce Armstrong

Approved for public release: distribution unlimited.

THIS TRANSLATION IS A RENDITION OF THE ORIGINAL FOREIGN TEXT WITHOUT ANY ANALYTICAL OR EDITORIAL COMMENT STATEMENTS OR THEORIES ADVOCATED OR IMPLIED ARE THOSE OF THE SOURCE AND DO NOT NECESSARILY REFLECT THE POSITION OR OPINION OF THE NATIONAL AIR INTELLIGENCE CENTER.

PREPARED BY:

TRANSLATION SERVICES  
NATIONAL AIR INTELLIGENCE CENTER  
WPAFB, OHIO

GRAPHICS DISCLAIMER

All figures, graphics, tables, equations, etc. merged into this translation were extracted from the best quality copy available.

## REFLECTORS FOR HIGH-POWERED CO<sub>2</sub> LASERS\*

Li Xiaoping, Zhou Fengqing, Lu Hong,  
Wang Jinhua, and Chen Qingming

National Laboratory of Laser Technology,  
HUST

Li Ao

Department of Chemistry, HUST

**ABSTRACT:** The method of designing, measuring, and preparatory and cooling techniques, used for high-powered CO<sub>2</sub> reflectors, have been discussed. The influence of the various substrate materials on the reflector has been compared. The results of applications demonstrated that reflectance of the reflector is higher, the higher the coating film hardness, and thermal deformation is smaller than for reflectors whose substrate is copper and that are gold-film coated. In addition, dirt on this kind of reflector can be cleaned with an organic solvent.

**Key Words:** high-powered CO<sub>2</sub> laser, reflector, coating, cooling.

\* This is a project sponsored by the Natural Sciences Foundation of Hubei Province and State Laser Technology Key Laboratory.

### I. Introduction

Reflectors are a vitally important optical element as far as

high-powered CO<sub>2</sub> laser devices are concerned, and reflector performance indicators, such as reflectance, deformation, thermal conductivity, as well as its optical durability, strongly affect laser beam quality and output power. Technically, when a reflector with inadequate reflectance is used as a reflection element for a multiple-folded optical cavity, two scenarios may occur, i.e., on the one hand, the larger number of folds may lead to an increase in attenuation, which makes the gain fail to reach threshold and eventually affects laser emission, and on the other hand, the smaller number of folds can make the pattern fail to meet the requirement. Still, when the reflector is used as an element inside and outside an ordinary optical cavity, high light power consumption is found.

In developed countries such as the United States, Japan, as well as other western countries, a hybrid structure of silicon (Si) substrate+metal+medium film has been used for high-powered CO<sub>2</sub> laser devices compared with the outdated application of gold-coated copper (Cu) substrate reflectors to most CO<sub>2</sub> laser devices as is the case in China. By a comparison of the silicon substrate with the copper substrate, the reflector in the former application exhibits less deformation (including thermal deformation and deformation excited by barometric pressure differences inside and outside the cavity; therefore, the deformation mentioned below is hereinafter referred to as of both kinds, unless otherwise specified) during laser operation; in addition, its reflectance exceeds 99.5% as compared to the only 98% of a new gold-coated reflector, which may drop after a period of time in use; moreover, the film cannot be cleaned once contaminated. It is therefore determined that the same laser device with different reflectors may provide entirely different output optical power and laser beam quality under the same conditions. Obviously, a reflector with a silicon substrate is far superior to one with copper substrate. It is understood that preferable laser beam quality is an indispensable precondition

for laser cutting and welding [1,2].

This paper presents a general description of a special reflector with a hybrid structure of silicon substrate+metal+medium film and, at the same time, it describes a required cooling method in the application of the laser device, along with a design of the film coating and its preparatory technology. This reflector takes precedence over the reflector with a gold-coated copper substrate with regard to laser output beam quality, film intensity, and thermal stability. Experiments suggest that the reflector discussed in this paper, when mounted on 2 to 10kW lasers, shows a more promising improvement over the reflector with gold-coating copper substrate in terms of laser output beam quality and power.

## 2. Substrate Selection and Cooling

In light of the substrate advantages and disadvantages, consideration should be given to the factors of material, including thermal conduction and thermal deformation, etc. In other words, the best choice is a material with features of rapid thermal conduction, low thermal deformation, and easy machinability. It is understood that substrate materials used to fabricate high-powered CO<sub>2</sub> laser reflectors are normally copper, molybdenum, silicon, and germanium. Following is a comparison of the advantages and disadvantages of copper and silicon substrates, as shown in the Table. Typically, pure copper, with its unique features such as high thermal conductivity, easy recovery of absorbed laser energy, in conjunction with its low cost, has widespread applications. Nevertheless, on the other hand, pure copper shows a rather high coefficient of thermal expansion. From a rule of thumb when applied to high-powered CO<sub>2</sub> laser reflectors, improvement in beam quality is achieved only at the high expense of output beam power because of large deformation (thermal deformation and deformation

Table The comparison of different reflector substrate materials

performance	material	
	copper	silicon
thermal conductivity ( $\text{W}\cdot\text{cm}^{-1}\text{K}^{-1}$ )	3.94	1.4
hardness( $\text{kg}/\text{mm}^2$ )	160	1150
coefficient of expansion ( $\text{K}^{-1}$ ) $\times 10^6$	16.5	2.5

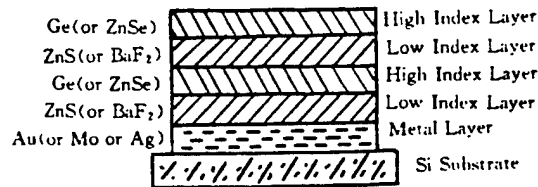

Fig.1 Schematic diagram of silicon mirror

caused by the barometric pressure difference inside and outside the cavity). In addition, pure copper tends to be soft and not suitable for optical polishing. Whereas in the application of the grinding and polishing method, a copper reflector is coated with nickel (or chromium) after rough grinding, which is then carefully polished for the required accuracy and fineness and finally, the nickel film is coated with gold. This is a common approach, currently used in China to fabricate copper mirrors.

Silicon is used as the base material for high-powered  $\text{CO}_2$  laser reflectors simply on the grounds that its coefficient of thermal expansion appears to be extremely small (only 15% that of copper). As a result, silicon shows far better thermal stability than copper, and its reflector surface is less apt to undergo thermal deformation, which is genuinely critical to the improvement of laser beam quality and enhancement of output light power. Among other factors, silicon, with its desired hardness,

can be optically polished without much difficulty. To sum up, silicon is superior to copper as substrate.

Reflectors for high-powered laser devices, whatever the material they are made of, are required to go through a cooling process, otherwise the laser device cannot carry out its routine work. Additionally, silicon is difficult to machine, that is, unlike copper it cannot be machined with a cooling water pipe and tapped and mounted. Under this circumstance, the following approach can be applied as a solution: a beam stronger than 2kW can be dealt with by using a cooling jacket, as indicated in Fig. 1. For beams weaker than 2kW, thermally conductive rubber can be mounted between reflector lens and metal.

### 3. Substrate Design, Preparation, and Testing

#### 1. Substrate design

Both the computational formulas and the related symbols designed in this paper can be seen in [4]. The reflector discussed in this paper is designed by coating the silicon surface that has been optically polished (F-stop number  $N$  less than or equal to 1, irregularities  $\Delta$  less than or equal to 0.1, and fineness = 1) with a high-reflectance film, as shown in Fig. 2; this allows over 99.5% of reflectance at  $10.6\mu\text{m}$ . The metal layer is made of a material such as gold, silver, molybdenum, and the like while the medium layer is zinc selenide and barium fluoride, or germanium and zinc sulfide. Zinc selenide or germanium is a high-reflectance material with reflectance values of 2.4 and 4.0, respectively, while zinc sulfide or barium fluoride is a low-reflectance material with reflectance values of 2.2 and 14, respectively.

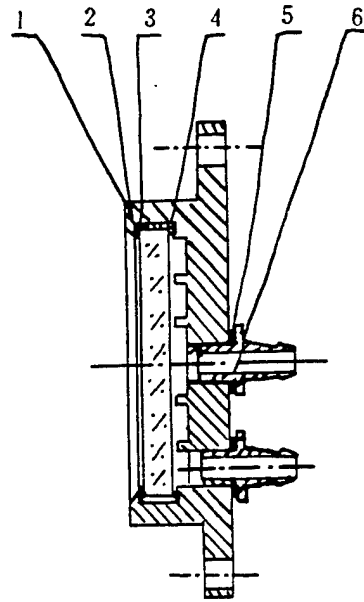

Fig. 2 Schematic diagram of cooling for silicon mirror

1 - mirror mount 2 - wear washer 3 - silicon mirror 4 - seal of rubber 5 - waterpipe of cooling 6 - seal of rubber

The hybrid refraction ratio of metal,  $n - ik$ , for the case of normal incidence in air has a reflectance as follows:

$$R = \frac{1 - [2n/(1 + n^2 + k^2)]}{1 + [2n/(1 + n^2 + k^2)]}$$

Computations and experiments show that when the metal film coating is too thick (large plate), 99.5% reflectance cannot be realized at  $10.6\mu\text{m}$ ; e.g., the reflectance can exceed 98% when the metal film thickness is  $400\text{\AA}$ . Therefore, excessively thick metal film is not suggested, especially when it comes to a valuable metal such as gold.

If a metal film is coated with four medium films with reflectance values  $n_1$  and  $n_2$  and a thickness  $\lambda_0/4$  and if  $n_2$  closely adheres to the metal, then the admittance of the wavelength during normal incidence, is as follows:

$$Y = \left( \frac{n_1}{n_2} \right) (n - ik)$$

Its reflectance is:

$$R = \left( \frac{1 - Y}{1 + Y} \right) \left( \frac{1 - Y}{1 + Y} \right)^*$$

As for zinc selenide and barium fluoride, as well as germanium and zinc sulfide, they both meet the conditions of

$$(n_1/n_2) > 1.$$

Computation shows reflectors with a hybrid structure of silicon substrate+metal+medium, i.e., Si/metal/BaF<sub>2</sub>/ZnSe/BaF<sub>2</sub>/ZnSe/air, or Si/metal/ZnS/Ge/ZnS/Ge/air, in which the metal is gold or silver or molybdenum, all showing a reflectance upwards of 99.5%.

## 2. Film preparation

The film preparatory process was conducted on a home-made DMDE-450 film coating unit, with gold and silver evaporated with an electron beam gun.

## 3. Film test

The film test consists of two parts: optical performance and mechanical intensity. For reflectors prepared with a silicon substrate+gold+medium (ZnS/Ge/ZnS/Ge) structure, we made a comparison with the reflectance for gold film and this present film, on a Hitachi model 260-50 spectrophotometer, made in Japan. At 10.6 $\mu$ m, with the reflectance of the device accessory (silver film) being scaled as 100%, we measured the gold film reflectance as 99.4%, while the reflectance of this present film was 103.5%, which is even better than silver.

In addition, an intensity comparison was made between the above-mentioned reflector and a gold-coated copper mirror on an SMC-1 film laboratory machine. The test was conducted at a positive pressure of 200g and a turning speed of 500rpm. After turning 20 times, the gold film exhibited scratches visible to the unaided eye and its surface was contaminated with dirt and oil stains, which could hardly be cleaned with cotton or gauze soaked with organic solvent, whereas the silicon mirror film, and 600 turnings, did not show any changes and only very fine

scratches could be observed under a magnifier. Even when it has turned 6000 times, still no visible damage could be found; furthermore, even when its surface was contaminated with dirt or oil stains, they could be cleaned completely with cotton or gauze soaked with acetone without damaging its surface. Obviously, this is one of the advantages of such reflectors.

#### 4. Applications and Results

The advantages of reflectors prepared with silicon substrate+gold+medium (ZnS/Ge/ZnS/Ge) include high reflectance, low deformation, high film intensity, as well as dirt and oil stains on its surface amenable to cleaning with cotton or gauze soaked in acetone without damaging reflector surface. When mounted on a conventional 2kW CO<sub>2</sub> laser device in place of a gold-coated copper mirror, with other conditions remaining unchanged, the maximum output power can rise from 2.2kW to 2.8kW, i.e., beam quality was greatly improved. Meanwhile, we have recommended this reflector to dozens of users throughout the national and it has exhibited desirable efficiency.

On the author: Li Xiaoping, male, born in April 1962, is an engineer who is now engaged in research on optical films and laser technology.

The paper was received on June 12, 1994.

#### PRODUCT PREVIEW

#### Nd:YAG LASER CUTTING SYSTEM

The LCS-III type Nd:YAG laser cutting system, produced by New Wave Research, Inc., in California, United States, can output three wavelengths: 1064nm, 532nm, and 355nm. It has wide applications such as designing and testing, fault analysis,

liquid-crystal display repairing, and other semiconductor applications. Its infrared light can be used to remove metal wires without damaging the silicon-base lens; green light is used to cut metals and eliminate oxides; and ultraviolet light is used to clean polyimides without affecting the substrate. By using a 50-power objective lens, the system can evenly and repeatedly perform cutting with a 50 $\mu$ m by 50 $\mu$ m cross section.

Reported by Zhang Xianyi and Liu Jianqing

DISTRIBUTION LIST

DISTRIBUTION DIRECT TO RECIPIENT

<u>ORGANIZATION</u>	<u>MICROFICHE</u>
BO85 DIA/RTS-2FI	1
C509 BALLOC509 BALLISTIC RES LAB	1
C510 R&T LABS/AVEADCOM	1
C513 ARRADCOM	1
C535 AVRADCOM/TSARCOM	1
C539 TRASANA	1
Q592 FSTC	4
Q619 MSIC REDSTONE	1
Q008 NTIC	1
Q043 AFMIC-IS	1
E404 AEDC/DOF	1
E410 AFDTC/IN	1
E429 SD/IND	1
P005 DOE/ISA/DDI	1
1051 AFIT/LDE	1
PO90 NSA/CDB	1

Microfiche Nbr: FTD96C000261  
NAIC-ID(RS)T-0006-96