

**GLASS WINDOW/WINDSHIELD  
REPAIR GUIDELINES**

# REPORT

**RICHARD J. OLSON**

**BATTELLE  
505 KING AVENUE  
COLUMBUS, OH 43201**

**AUGUST 1995**

**TECHNICAL REPORT FOR 09/91 - 6/95  
CONTRACT NUMBER FO9603-90-D-2217-SD02**

**DISTRIBUTION AUTHORIZATION: APPROVED FOR PUBLIC RELEASE;  
DISTRIBUTION IS UNLIMITED**

**PREPARED FOR  
OKLAHOMA CITY AIR LOGISTICS CENTER  
TINKER AFB, OK 73145**

 **Battelle**  
... Putting Technology To Work

*19960412 112*

**19960412 112**

**GLASS WINDOW/WINDSHIELD  
REPAIR GUIDELINES**

**RICHARD J. OLSON**

**BATTELLE  
505 KING AVENUE  
COLUMBUS, OH 43201**

**AUGUST 1995**

**TECHNICAL REPORT FOR 09/91 - 6/95  
CONTRACT NUMBER FO9603-90-D-2217-SD02**

**DISTRIBUTION AUTHORIZATION: APPROVED FOR PUBLIC RELEASE;  
DISTRIBUTION IS UNLIMITED**

**PREPARED FOR  
OKLAHOMA CITY AIR LOGISTICS CENTER  
TINKER AFB, OK 73145**

*This report is a work prepared for the United States Government by Battelle. In no event shall either the United States Government or Battelle have any responsibility or liability for any consequences of any use, misuse, inability to use, or reliance upon the information contained herein, nor does either warrant or otherwise represent in any way the accuracy, adequacy, efficacy, or applicability of the contents hereof.*

REPORT DOCUMENTATION PAGE			Form Approved OMB No. 0704-0188	
Public reporting burden for this collection of information is estimated to average 1 hour per response, including the time for reviewing instructions, searching existing data sources, gathering and maintaining the data needed, and completing and reviewing the collection of information. Send comments regarding this burden estimate or any other aspect of this collection of information, including suggestions for reducing this burden, to Washington Headquarters Services, Directorate for information Operations and Reports, 1215 Jefferson Davis Highway, Suite 1204, Arlington, VA. 22202-4302, and to the Office of Management and Budget, Paperwork Reduction Project (0704-0188), Washington, DC 20503.				
1. AGENCY USE ONLY (Leave blank)	2. REPORT DATE February 1996	3. REPORT TYPE AND DATES COVERED Technical, 9/01/91 - 6/30/95		
4. TITLE AND SUBTITLE Glass Window/Windshield Initial Repair Guidelines			5. FUNDING NUMBERS	
6. AUTHOR(S) Richard J. Olson				
7. PERFORMING ORGANIZATION NAME(S) AND ADDRESS(ES) Battelle 505 King Avenue Columbus, Ohio 43201-2693			8. PERFORMING ORGANIZATION REPORT NUMBER Contract FO9603-90- D-2217-SD02	
9. SPONSORING/MONITORING AGENCY NAME(S) AND ADDRESS(ES) Oklahoma City Air Logistics Center OC-ALC/TIET-R 3001 Staff Drive, Suite 2AG70A Tinker AFB, OK 73145-3040  Technology Transition Office AFMT TTO/TTP 2690 C, Suite 5 Wright-Patterson AFB, OH 45433-7412			10. SPONSORING/MONITORING AGENCY REPORT NUMBER VEP87CR52R1	
11. SUPPLEMENTARY NOTES				
12a. DISTRIBUTION/AVAILABILITY STATEMENT Approved for public release; distribution is unlimited			12b. DISTRIBUTION CODE	
13. ABSTRACT (Maximum 200 Words) Information on the technology used in the OEM production of glass airplane W/WS and the methods used to repair them is presented in this report. The technology for making glass transport-type aircraft W/WS is not particularly high-tech; glass and plastic are laminated together under heat and pressure. Likewise, the major repair processes for such W/WS are also quite simple; relamination and polishing to remove scratches. Some of the repair vendors use patented or proprietary innovative repair techniques to allow them to differentiate themselves from their competitors and to salvage W/WS that would otherwise be scrapped.  With respect to the impact of the information learned during this study on using repaired glass W/WS on military transport-type aircraft, with little exception, nothing was uncovered that would preclude the Air Force from considering using repaired W/WS. So long as the structural performance and economics are acceptable, the use of repaired W/WS should be pursued.				
14. SUBJECT TERMS Aircraft Transparencies, Windows/Windshields, Repair, Grinding, Polishing, Relamination			15. NUMBER OF PAGES 20	
			16. PRICE CODE	
17. SECURITY CLASSIFICATION OF REPORT Unclassified	18. SECURITY CLASSIFICATION OF THIS PAGE Unclassified	19. SECURITY CLASSIFICATION OF ABSTRACT Unclassified	20. LIMITATION OF ABSTRACT Unlimited	

*This page intentionally left blank.*

## TABLE OF CONTENTS

	<u>Page(s)</u>
REPORT DOCUMENTATION PAGE .....	iii
TABLE OF CONTENTS .....	v
LIST OF FIGURES .....	v
SUMMARY .....	vi
PREFACE .....	vii
1.0 INTRODUCTION .....	1
1.1 Background .....	1
1.2 Objective .....	1
1.3 Approach .....	1
1.4 Report Contents .....	2
2.0 GLASS W/WS CONSTRUCTION .....	2
3.0 GLASS W/WS DAMAGE .....	4
4.0 USAF REMOVAL FOR CAUSE CRITERIA .....	6
5.0 W/WS REPAIR TECHNOLOGY .....	7
5.1 W/WS Repairs .....	7
5.1.1 Electrical Heater System Repair .....	7
5.1.2 Delamination Repair .....	8
5.1.3 Glass Repair .....	10
5.1.4 Seal and Bumper Repairs .....	12
5.1.5 Frame Clean-Up or Repair .....	12
6.0 SUMMARY .....	12
7.0 REFERENCES .....	13

## LIST OF FIGURES

	<u>Page(s)</u>
Figure 2.1 C/KC-135 and B-52 W/WS General Construction .....	2
Figure 5.1 The Glass Doctor Patented Technique for Repair of Delaminations Glass W/WS, U.S. Patent # 4,780,162 .....	9
Figure 5.2 The Glass Doctor Patented Technique for Repair of Conical Cracks in Laminated Glass, U.S. Patent # 3,841,932 .....	11

## SUMMARY

Information on the technology used in the OEM production of glass airplane W/WS and the methods used to repair them has been assembled. The technology for making glass transport-type aircraft W/WS is not particularly high-tech; glass and plastic are laminated together under heat and pressure. Likewise, the major repair processes for such W/WS are also quite simple; relamination and polishing to remove scratches. Because W/WS repair is so elementary, all of the commercial W/WS repair vendors use the same basic tools and techniques.

Some of the repair vendors use patented innovative techniques: repair of delamination by adhesive injection, sensor replacement, busbar repair by conductive adhesive injection, while others use proprietary technology: front ply replacement. Use of these techniques provide opportunities to salvage W/WS that would otherwise be scrapped. Because basic W/WS repair is so simple, both of these methods are used by repair vendors to allow them to differentiate themselves from their competitors.

With regard to the suitability of using repaired glass W/WS on military transport-type aircraft, nothing learned during this investigation would preclude the Air Force from considering using repaired W/WS. There are some cautions that must be raised:

- 1) The adhesive injection, either for busbar repair or delamination repair, because it is practiced by only one repair vendor and because it is somewhat controversial, needs to be evaluated.
- 2) Quality control procedures must be in place to make certain that you are getting the product that you paid for (superficially an unrepaired W/WS can look just like a new W/WS).
- 3) Proprietary products (seal materials, coatings, etc.) may be available and these may be superior to the currently used products.

With these few cautions, so long as the structural performance and economics are acceptable, the use of repaired W/WS should be pursued.

## PREFACE

The work reported herein was performed by Battelle, Columbus, Ohio, under Air Force Contract FO9603-90-D-2217-SD02, "Development of Repair Processes and Sources for C/KC-135 and B-52 Aircraft Windows/Windshields." The program was directed by the Oklahoma City Air Logistics Center (OC-ALC) at Tinker Air Force Base. Air Force administrative direction was provided by Ms. Cindy Cooper, OC-ALC/LADCB. Air Force technical direction was provided by Mr. Robert Koger, OC-ALC/TIETR.

The work was performed during the period of September 1991 to June 1995. The technical program at Battelle was directed by Mr. Richard Olson of Battelle's Engineering Mechanics Department. The author wishes to acknowledge Mr. Wayne Fisher and Mr. Herb Goodrich of PPG Industries, Inc. Aircraft Products Division in Huntsville, Alabama and Mr. Dick Forler at The Glass Doctor in St. Petersburg, Florida for providing general insight into W/WS manufacture and repair, and Mr. Ryan Rice at Battelle for preparation of the manuscript.

## **1.0 INTRODUCTION**

### **1.1 Background**

Several facilities currently exist for repairing glass aircraft windows/windshields (W/WS), and with U.S. Federal Aviation Authority (FAA) approval, many commercial airlines are currently utilizing these services. For commercial fleets, W/WS represent the fifth highest airplane operating expense, behind engines, fuel, tires, and brakes. Because the cost of repairing a cockpit W/WS is substantially less than the purchase price of a new W/WS for commercial fleets, there is a large incentive for them to use repaired W/WS. The U.S. Air Force (USAF), on the other hand, has historically rejected the notion of using repaired W/WS. With decreasing Congressional funding for the military, however, measures to reduce fleet operating costs are receiving greater scrutiny. Thus, the use of repaired W/WS is being given serious consideration.

In September 1991, the Air Force contracted with Battelle to investigate the consequences and impact of using repaired glass cockpit W/WS. The primary focus of the study was to evaluate the feasibility of using repaired W/WS by testing the functional performance of repaired W/WS and by performing a new versus repaired W/WS cost analysis. As a secondary activity, the study also assembled information on the technology used in the OEM production of glass airplane W/WS and the methods used to repair them. This report documents the results of that effort.

### **1.2 Objective**

The objective of the work reported herein is to determine if there are inherent features, either in the manufacture or repair of glass cockpit W/WS, that would preclude the Air Force from considering the use of repaired W/WS.

### **1.3 Approach**

The approach used to collect the data needed to assess the viability of using repaired W/WS was to use patent abstracts, the open technical literature, and advertising brochures from commercial aircraft W/WS repair vendors. In general, the aircraft W/WS repair business is very competitive and the repair vendors and W/WS OEM's treat their process information as a trade secret or they have patented it. Because of this, specific process details are not typically available. General comments and observations about the repair processes can, however, be made.

## 1.4 Report Contents

The results of this study are presented in the sections that follow. Topics presented include:

- Glass W/WS construction
- Glass W/WS damage
- W/WS repair technology
- Summary.

## 2.0 GLASS W/WS CONSTRUCTION

To provide a context for discussing W/WS repairs, it is important to understand the construction of glass cockpit W/WS. For the purposes of this report, C/KC-135 and B-52 glass cockpit W/WS will be used as the basis for the discussions.

Figure 2.1 shows the general construction of the glass C/KC-135 and B-52 W/WS. The W/WS have a three-part glass and vinyl laminate construction. The inner layer is thick, heat-strengthened plate glass designed to withstand cabin pressure forces. A transparent, plasticized, polyvinyl butyral core layer acts as the "fail-safe" load carrying member and prevents shattering in the event of inner ply failure. The outer ply is a relatively thin layer of heat-strengthened glass with no structural significance, but it provides rigidity and a scratch-resistant surface. A phenolic or masonite filler strip, located around the edge of the W/WS, and a metal filler strip embedded in the vinyl provide the means to attach the W/WS to the airframe. Vinyl or vinyl and rubber bumpers protect the edges of the glass plies.

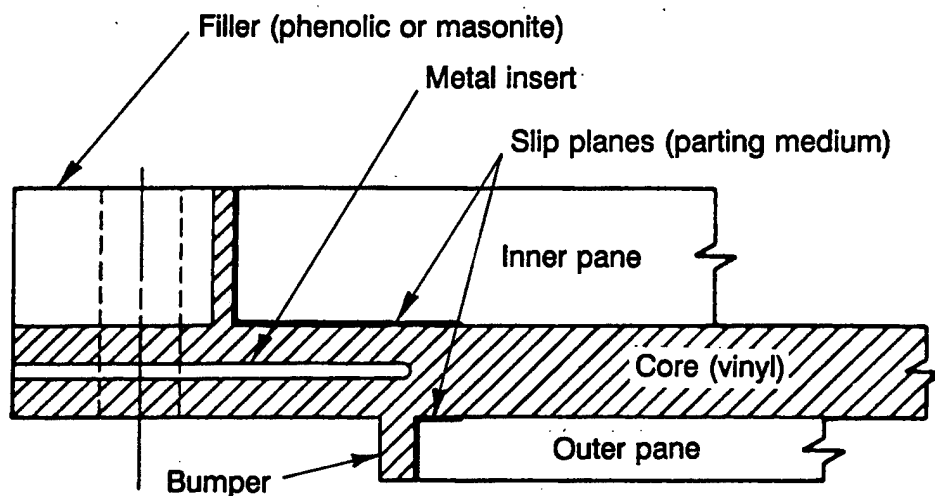

Figure 2.1 C/KC-135 and B-52 W/WS General Construction

The structural integrity design of C/KC-135 and B-52 cockpit W/WS is based on two requirements: "fail-safe" pressure integrity and bird impact resistance. The "fail-safe" pressure integrity is founded on two redundant systems, an inner glass ply that can sustain the full rated cabin pressure in the absence of all other layers, and a polymeric core ply that can maintain pressure integrity if the inner and outer glass plies are cracked. The bird impact structural integrity of W/WS is either characterized as "bird bagging" or "bird bounce." Bird bagging W/WS, typically two glass layers with a polymeric core ply, stop bird penetration by large ductile deformation of the core ply, i.e., "bagging" the bird. Bird bounce W/WS are typically multilaminates and cause the bird to "bounce" off the W/WS. The C/KC-135 and B-52 W/WS cockpit W/WS are "bird bagging" W/WS.

The glass used in C/KC-135 and B-52 W/WS is heat strengthened to provide resistance to cracking. The glass is heated to near the softening point and then quenched to produce compressive residual stresses that extend from the outer surface into a depth of about 1/6<sup>th</sup> of the glass thickness. Below the compressive stress layer lies tensile residual stresses. As long as surface defects do not penetrate into the tensile layer, the glass will exhibit a high resistance to fracture. Once a crack does fully penetrate the tensile layer, the glass will shatter as the tensile stresses are relieved.

The vinyl core, which acts as the "fail-safe" pressure boundary and means for controlling glass fragments in the event of a glass ply failure, is highly plasticized polyvinyl butyral. The vinyl is relatively brittle at low temperatures (-65° F), and unable to absorb much energy per unit volume. At temperatures approaching 130° F, the vinyl becomes very ductile and can absorb a relatively large amount of energy as it is loaded. W/WS heaters, which not only de-fog and de-ice the glass, ensure that the vinyl remains ductile.

An integral part of the C/KC-135 and B-52 W/WS construction is slip planes or a parting medium at the edges of the glass. A slip plane is located between both the inner glass ply and the vinyl and the outer glass ply and the vinyl as shown in Figure 2.1. The slip planes are thin strips of material at the glass-vinyl interface that keep the glass from bonding to the vinyl. This allows the various plies to move independently at these locations in response to pressure loads and differential thermal expansion. Without the slip planes, the glass at the edges of the W/WS would be prone to fracture because it would exceed its strain limit as it tried to move with the underlying vinyl. The slip planes form a "softer" connection that promotes a more gradual build up of strains in the glass so that it does not exceed its strain capacity. Although the slip planes look similar to delamination, they are not defects but an intentional part of the W/WS design.

The C/KC-135 and B-52 cockpit W/WS contain heating systems for anti-icing and/or anti-fogging. An electrically conductive film of pyrolytic tin oxide between the outer glass ply and the vinyl core ply is used to heat C/KC-135 and B-52 W/WS to reduce ice/frost formation. A similar conductive film between the inner ply and core ply is used on some W/WS for defogging only. The W/WS heating system, so called NESAS<sup>®</sup> coated glass, uses the resistivity of the film to provide the heating. A few of the C/KC-135 and B-52 W/WS also contain fine wires at the W/WS edges between the outer glass ply and vinyl, so-called edge heaters, to correct a heating power deficiency in the corners. The temperature of some W/WS is

controlled with an integral sensor embedded in the laminate. Externally applied thermal switches control the temperature on other W/WS.

Seals on the W/WS keep cabin pressure in and moisture out. In addition, they act as vibration and shock absorbers and help to compensate for differential thermal expansion between the W/WS and the airframe. The C/KC-135 W/WS utilize a silicone rubber molded-in-place pressure seal that is molded to the W/WS mounting surface. A few of the molded-in-place seals have a stainless steel z-channel sandwiched between a silicon rubber cushion and the beaded pressure seal. The B-52 W/WS use either molded-in-place seals or pre-made polysulfide rubber seals that are glued onto the W/WS frame with polysulfide rubber. All of the C/KC-135 and B-52 W/WS, except the B-52 escape hatch W/WS, mount from the inside of the aircraft. Drawing the W/WS tight to the airframe with their mounting bolts effects the seal.

Many of the W/WS on the C/KC-135 and B-52 are flat. The W/WS directly in front of the pilot fall into this category. Because they are flat, they are easy to manufacture and repair. In addition, they have very good optics. Several of the C/KC-135 and B-52 W/WS are curved. Some of them have a single axis of curvature, while others have compound curvature. The curvature tends to result in some degree of optical distortion, and the curvature makes it somewhat more difficult to repair than the flat W/WS, in spite of the fact that the curved W/WS are generally smaller than the flat ones.

### 3.0 GLASS W/WS DAMAGE

The most common failure modes of laminated glass transparencies are:

- Delamination: separation of vinyl from the glass
- Cracks and chipping: glass breakage due to high stress
- Arcing: unbalanced electrical potential within the conductive coating
- Heater Failure: loss of continuity in the heater or sensor circuit or low power
- Impaired Vision: due to surface scratches, contaminates, or internal defects
- Contamination: air or water leaks caused by defective seals
- Vinyl cracking.

Delamination is separation of the glass surface of the inner or outer ply from the vinyl core ply to which it is bonded. Delamination generally starts at the slip planes and moves inward, although it may occur anywhere in the W/WS. It mainly occurs between the outer ply and the vinyl ply. Delamination does not dramatically reduce the strength of the W/WS, but may interfere with vision or W/WS heating if the delamination occurs at the interface where the heating film is located.

Cracks and chips may occur in either of the glass plies and may be caused by impacts or by high stresses at the edges of the glass. Single cracks in the outer ply are unlikely because the temper in this layer precludes a single crack. After the momentary appearance of a crack in the outer layer, the entire layer shatters very abruptly. Small cracks very near the edges of the W/WS may not be cause for removal, provided the crack is not directed toward the center

of the pane. Cracks that adversely affect the functioning of the heater would not be acceptable. Chips may occur internally or externally. Internal chips are caused by the glass-vinyl bond strength exceeding the strength of the glass. External chips are generally caused by impacts. Chips usually have a clamshell shape, are rough, and white powdered glass is often in evidence. Chips are detrimental to the strength of the pane.

W/WS busbar breakdown and faults in the heater film cause arcing. Basically, the insulation breaks down and the heater electrical current short circuits to the airframe. Arcing is evidenced by burned areas around electrical braid and along the busbar.

The failure of the W/WS heater to de-ice or defog satisfactorily is one of the most serious failure modes. Arcing, chips, cracks, or lack of continuity in the heater film that render the heater inoperative are cause for W/WS replacement. Uneven heating or hot spots caused by delamination at the glass-vinyl interface with the heating film or chips may also be a cause for removal. As W/WS age, the resistance of the heater generally rises. In order to provide the same power for defogging or de-icing, the voltage applied to the W/WS must be increased. At the maximum possible voltage (which is governed by the design of the W/WS autotransformer and the current carrying capacity of the wiring to the W/WS), if the W/WS heater resistance is above allowable specifications, the heater will be perceived as being ineffective.

Satisfactory optical properties of the W/WS are paramount. Foggy or cloudy areas may appear in places where moisture has penetrated the vinyl and has begun to degrade it. Scratches may occur on both the inner and outer plies that may interfere with visibility. Likewise, delamination may become serious enough to warrant replacement of the W/WS on the basis of reduced visibility. Bubbles may occur in the vinyl core ply in W/WS that have been exposed to elevated temperatures. Bubbles are caused by gas liberated from the vinyl, and grow in size and number with increased temperature or longer exposures. Needless operation of the heaters on the ground is a prime cause of bubbles. Bubbles do not have a large effect on strength of the W/WS, but may become serious enough to impair visibility. Although other failure modes may not be evident, poor optical performance is always a sufficient cause for W/WS replacement.

The bumpers on the edges of the glass form a moisture barrier. Degradation of bumpers in the form of cracking or separation from the edge of the glass ply can allow moisture and air to get into the slip planes. Moisture can degrade the heater film with consequent initiation of heater failure, arcing, delamination, and contamination.

As a result of aging, cracks may occur in the vinyl. Over time, attack by ultraviolet radiation and high temperatures also causes the vinyl to lose ductility. Eventually, cracks may form around the periphery of the W/WS in proximity to the metal insert as the glass and vinyl try to move relative to one another. Vinyl cracks significantly weaken the structure of the W/WS by putting flaws directly in the load path between the transparency and the airframe for bird impact loads. Per Figure 2.1, only the vinyl extends out to the mounting holes, not the glass. Therefore, if the vinyl is cracked near the metal insert, the W/WS could just "punch out" of the frame into the cabin in a bird impact situation. The vinyl layer is also the pressure "fail-safe" layer, so vinyl cracks are quite important.

In addition to cracking, the vinyl layer may discolor or darken if it is subjected to temperatures in excess of 225° F. Foreign substances in the glass-vinyl interface, either from in-service conditions or introduced as a part of a repair process, may also cause discoloration.

#### 4.0 USAF REMOVAL FOR CAUSE CRITERIA

The W/WS replacement criteria in the C/KC-135<sup>[1]</sup> and B-52 W/WS<sup>[2]</sup> Technical Orders are founded on two major principles:

- 1) A W/WS that has any condition that impairs visibility must be replaced
- 2) The W/WS heater must function properly.

A number of specific inspection items, subordinate to these principles, provide additional criterion for W/WS replacement. These subordinate criteria include:

##### Outer Glass Ply

- Cracks which extend more than 1/4 inch from the edge of the glass or that are directed toward the center of the pane

##### Inner Glass Ply

- Cracks of any kind
- Scratches deeper than 0.015 inch
- V-shaped chips of any kind
- Conchoidal chips at either glass surface deeper than 0.015 inch

##### Middle Vinyl Ply

- Bubbles within 1/2-inch of the metal insert
- Cracks that run parallel to the metal frame insert (typically within 1/4-inch of the metal insert)

##### Frame and Seal

- Cracks in the vinyl or rubber bumper.

As long as the primary criteria are satisfied and none of the secondary criteria are met, W/WS are not replaced. Burned areas around busbars, cracks in electrical terminal blocks, bubbles in the vinyl inboard of the metal insert, small and/or numerous scratches, or delamination, etc. are tolerated, so long as the heater works and visibility is not impaired. W/WS are not currently not removed solely because they are old or because they have been on a large number of missions.

## **5.0 W/WS REPAIR TECHNOLOGY**

The manufacture of a new W/WS is conceptually quite simple - two layers of glass are bonded together with vinyl under heat and pressure to form an optically acceptable transparency. Likewise, repairing a damaged W/WS is also conceptually simple - rebond separated laminates, and remove unacceptable scratches, chips, and cracks. Unfortunately, although the concept of manufacturing a new W/WS or repairing a damaged one is quite simple, the implementation requires a great deal of "art" and practice to become skilled at making successful repairs.

There are currently six prominent commercial aircraft W/WS repair stations: NORDAM Transparency Division; Perkins Aircraft Services, Inc.; The Glass Doctor; PPG Industries, Inc. Aircraft Products Division; Pilkington Aerospace, Inc., and Sierracin/Sylmar. Each of these companies has developed the necessary techniques and skills to become an FAA-certified W/WS repair station. In all cases, the concepts involved in their repair processes are as simple as described above. The actual reduction to practice of the concepts, however, is either treated as a trade secret or is covered by patents.

### **5.1 W/WS Repairs**

Based on knowledge of typical aircraft cockpit W/WS construction and commercial repair vendor practices, repairs fall into five categories:

- Electrical heater system repair
- Delamination repair
- Glass repair
- Seal and bumper repairs
- Frame clean-up/repair.

The repairs are generally limited to the exterior surfaces that are accessible without disassembling the windshields, but there are some exceptions.

#### **5.1.1 Electrical Heater System Repair**

Typically, electrical heater repair is limited to re-connecting the wiring when the resistance reading of the power or sensor circuits is infinite. W/WS with resistance readings outside the acceptable ranges, other than open circuits, are deemed unserviceable.

An open circuit can possibly be repaired by manually soldering the accessible breaks in the electrical braid in a work bench set-up. The repair effort for the electrical heater is minimal as the exposed circuitry is limited. Corrosion can be removed from exposed terminal blocks using a fine grade abrasive.

Repair of open or arcing busbars can also be effected by injecting a conductive adhesive material into the glass-vinyl interface where the busbar defect is located. The needle of a hypodermic syringe is forced into the glass-vinyl interface to inject the adhesive. Because the

busbar is located at the edge of the W/WS, the pilot is unaware of the repair. This repair technique is covered by patents owned by The Glass Doctor and hence is only performed by them.

Another heater system repair performed exclusively by The Glass Doctor is replacement of defective sensors. In this process, the replacement sensor is fabricated from an appropriate temperature-sensitive wire by winding it on a small-diameter mandrel. The new sensor is potted with clear adhesive in a hole drilled in the W/WS vinyl in the vicinity of the defective sensor. The old sensor is disconnected from its terminal block and new wires going from the new sensor to the terminal block are placed in grooves machined into the masonite or phenolic filler strip. The wires are potted in the filler strip with an adhesive.

Cosmetically, the repaired sensor looks like a small nail embedded in the W/WS. So long as the heat treatment of the new temperature-sensitive wire matches the OEM sensor wire, the sensor should respond to temperature just like new ones. However, because the OEM sensors are flat and are between one- and two-square inches, the original sensor will respond to the average temperature over a larger area than the replacement sensor. This is not likely a problem since the tolerance on sensor and W/WS resistance probably overshadows any potential benefits from the OEM sensor averaging. Whether or not drilling into the vinyl degrades the structural performance of the W/WS is not clear.

### 5.1.2 Delamination Repair

Delamination between the glass and vinyl plies of the W/WS greater than 40-percent of the W/WS area, or vinyl tearing is deemed unserviceable and the W/WS is scrapped. The use of an autoclave to laminate glass sheets, laminates, and transparencies is cited in a number of patents. A 1967 PPG Industries Inc. patent, # 3,311,517<sup>31</sup>, cited an oil autoclave curing cycle of "up to 30 minutes or more at a temperature of about 190 to 325 degrees Fahrenheit, preferably about 225 to 300 Fahrenheit, and simultaneous pressures of between 100 and 250 pounds per square inch, depending on the thickness of the components of the assembly to be laminated and the number of interfaces between the components." This curing cycle does not include the times for tasks such as autoclave set-up, windshield (un-)bagging and (un-)loading by the operator, or cool down period. The use of autoclaves that use oil to apply pressure to the W/WS has been superseded by autoclaves that apply pressure using air, with the W/WS in vacuum bags.

In addition to removing general delamination between plies in a W/WS, re-autoclaving is also used to remove bubbles formed when the W/WS heaters are energized while the plane is on the ground.

Delamination repair by injection of adhesives into the W/WS is also done. Unlike the other aircraft W/WS repair vendors, The Glass Doctor does not rely solely upon re-autoclaving of W/WS to effect delamination repairs. As described in U.S. patent #4,780,162<sup>41</sup>, The Glass Doctor repairs delamination repairs by injecting an adhesive between the delaminated plies per Figure 5.1.

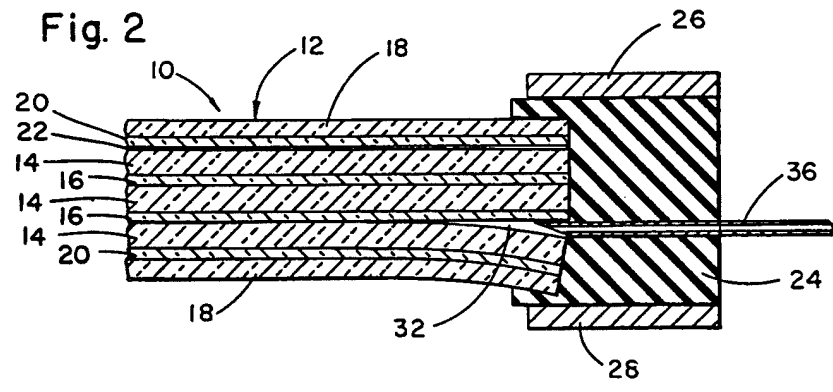
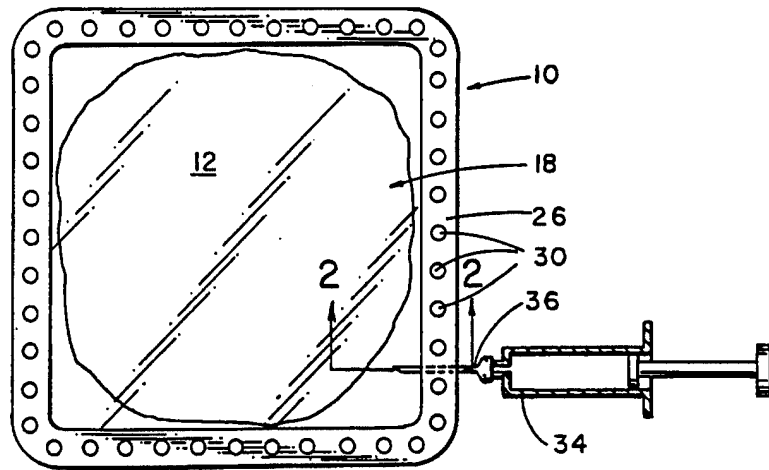

Figure 5.1 The Glass Doctor Patented Technique for Repair of Delaminations in Glass W/WS, U.S. Patent # 4,780,162

The clear adhesive fills the void created by the delamination and bonds the glass to the vinyl. Because delamination almost always moves in from the edges of the W/WS, the adhesive may bond the slip plane material to the glass thus disabling the slip plane function. Experience suggests that the adhesive has been engineered to provide the required compliance in shear so edge chipping of the glass is not a problem. (PPG has eliminated the use of slip planes on commercial Boeing 707 W/WS by interposing a proprietary urethane layer between the glass and the vinyl.) So long as the adhesive can be made to flow completely into the void, the W/WS looks like new. Bubbles in the W/WS vinyl are not repaired with adhesive.

Long-term optical properties of the adhesive has been the subject of much debate in the W/WS repair industry. It has been claimed that the adhesive turns orange in time. The Glass Doctor currently performs QUV tests (high-intensity, simulated long-term, ultra-violet exposure tests) on every batch of adhesive that is mixed as part of their quality control procedures. The adhesive used is a proprietary product of The Glass Doctor.

### 5.1.3 Glass Repair

Repairable "minor" surface defects such as scratches, up to 0.005 inches deep, are polished, then blended to avoid optical distortion. Cracks or chips in the glass panels are generally not repairable, and the W/WS is deemed unserviceable and scrapped.

Spot polishing is mostly performed as a manual bench-top operation using hand-held, air-powered tools, such as palm sanders, with either bonded sheet abrasives or loose rare-earth compound abrasives such as cerium oxide. Stationary polishing belts are also available. However, it is not feasible to manually feed a 60-70 pound windshield for any length of time.

Polishing is a messy operation because it is usually done wet, requiring much manual effort and skill, and it relies extensively upon operator experience. Manual glass surface polishing on strengthened (tempered) glass is not widely performed outside of the aircraft industry because it is time consuming and the success is low due to the ease of introducing optical distortion. Aside from airplane W/WS, it is generally cheaper to replace a scratched W/WS than it is to polish it. For a 0.005-inch deep scratch, the defect would have to be "feathered out" over a width of  $\pm 3.82$  inches to preserve an optical deviation of 4.5 arc minutes, the standard for C/KC-135 main W/WS in the center viewing area of the W/WS.

For flat W/WS, the opportunity exists to grind and polish the entire surface of a W/WS. By mounting the W/WS on the table of a grinding machine, the flatness of the surface can be easily maintained and all surface defects can be removed. Labor is limited, because the complete surface of a W/WS is done at one time. Provided that the depth of grinding/polishing is not too deep, the optical performance of the W/WS can be restored.

For the most part, W/WS repair vendors scrap W/WS with chips in the glass. The Glass Doctor, however, has developed special techniques for repairing chips and nicks in W/WS. As described in U.S. patents #3,841,932<sup>[5]</sup> and #3,914,145<sup>[6]</sup>, The Glass Doctor repairs conical cracks by filling the crack with a polymerizable resin that is vibrated into place by motion of the conical plug, see Figure 5.2.

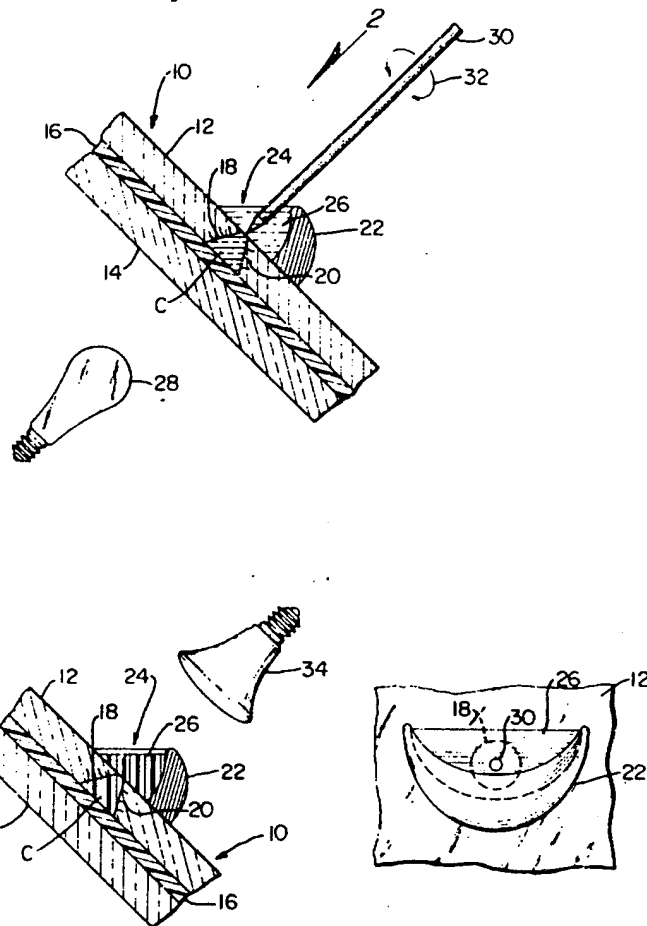

**Figure 5.2 The Glass Doctor Patented Technique for Repair of Conical Cracks in Laminated Glass, U.S. Patent # 3,841,932**

Although The Glass Doctor's chip repair technique is available, it is probably not used very much in the aircraft industry. Inner ply chip repairs are not candidates for use of this process because of concerns about strength degradation. Outer plys, because they are quite thin and have such high residual stresses, almost always would crack completely.

As a final resort, some repair vendors (PPG, Pilkington, and Sierracin) will replace the front glass ply of a W/WS. In this process, the glass ply and some or all of the underlying vinyl ply are removed and replaced. Generally speaking, the front ply is the most likely ply to delaminate and to be scratched or cracked. Replacing the front ply essentially restores the W/WS to a like-new condition. (PPG, for instance, gives a three-year warranty on W/WS with a new front ply.) For multi-ply bird bounce W/WS (Boeing 747, for instance), front ply replacement may be economical. For three-ply W/WS (C/KC-135 and B-52), front ply replacement is probably more costly than a new W/WS.

#### **5.1.4 Seal and Bumper Repairs**

Seals on all repaired W/WS are replaced and bumpers are cleaned up or repaired. The seals on the W/WS are either of the cast-in-place type, or the glue-on type. To replace a seal, the old one must first be peeled off and the W/WS frame surface cleaned, and a new seal installed.

With cast-in-place type seals, viscous liquid silicone rubber or polysulfide rubber is applied around the W/WS frame and a steel mold placed on top. After the rubber has cured, the mold is removed and the "squeeze-out" is trimmed. With the glue-on type seals, pre-cured strips of silicone or polysulfide rubber are attached with a thin layer of liquid rubber. The edges of the phenolic or masonite mounting blocks are generally protected with a brushed-on liquid rubber sealant.

The exposed edges of the glass, in some W/WS designs are protected with a vinyl, vinyl and rubber, or all rubber bumper either integral with the W/WS or glued on with adhesive. If the bumper has separated from the glass or if sealant that overcoats the bumper is damaged, the old sealant is removed by cutting and scraping and new sealant is reapplied to ensure that the W/WS is moisture-tight.

#### **5.1.5 Frame Clean-Up or Repair**

In the as-received condition at a W/WS repair station, W/WS will have paint and/or aerosmoothen sealant on the masonite or phenolic filler strip. In order to effect installation of the repaired W/WS, all of the superfluous paint and sealant is removed by scraping and sanding.

### **6.0 SUMMARY**

In this report, information on the technology used in the OEM production of glass airplane W/WS and the methods used to repair them has been assembled. The technology for glass transport-type aircraft W/WS is not particularly high-tech; glass and plastic are laminated together under heat and pressure. Likewise, the major repair processes for such W/WS are also quite simple; relamination and polishing to remove scratches. Because W/WS repair is so elementary, all of the commercial W/WS repair vendors use the same basic tools and techniques. Some of the innovative techniques: repair of delamination by adhesive injection, sensor replacement, busbar repair by conductive adhesive injection, and front ply replacement, provide opportunities to salvage W/WS that would otherwise be scrapped.

In terms of the impact on the suitability of using repaired glass W/WS on military transport-type aircraft, nothing learned during this investigation should preclude the Air Force from considering using repaired W/WS. There are some cautions that must be raised:

- 1) The adhesive injection, either for busbar repair or delamination repair, because it is practiced by only one repair vendor and because it is somewhat controversial, needs to be evaluated.
- 2) Quality control procedures must be in place to make certain that you are getting the product that you paid for (superficially an unrepaired W/WS can look just like a new W/WS).
- 3) Proprietary products (seal materials, coatings, etc.) may be available and these may be superior to the currently used products.

With these few cautions, so long as the structural performance and economics are acceptable, the use of repaired W/WS should be pursued.

## 7.0 REFERENCES

- 1) T.O. 1C-135(K)A-2-2, "Ground Handling, Servicing, and Airframe", Section VIII - Fuselage Windows, Paragraph 8-90.
- 2) T.O. 1B-52B-2-2, "Ground Handling, Servicing, and Airframe Maintenance", Section XI - Fuselage Windows, Paragraph 11-8B.
- 3) Keslar, Leroy D. and Rankin, John S., U.S. Patent # 3,311,517, "Method of Laminating Transparent Assemblies", March 28, 1967.
- 4) Forler, C. Richard, *et al*, U.S. Patent # 4,780,162, "Methods for Repairing Laminates", October 25, 1988.
- 5) Forler, C. Richard, *et al*, U.S. Patent # 3,841,932, "Methods and Apparatus for Repairing Cracks in Windshields", October 15, 1974.
- 6) Forler, C. Richard, *et al*, U.S. Patent # 3,914,145, "Methods and Apparatus for Repairing Cracks in Plate Glass", October 21, 1975.