

REPORT

ACCEPTABLE GLASS WINDOW/WINDSHIELD REPAIR PROCESSES AND APPROVED VENDORS

RICHARD J. OLSON

BATTELLE
505 KING AVENUE
COLUMBUS, OH 43201

FEBRUARY 1996

MATERIAL AND PROCESS SPECIFICATION REPORT FOR 09/91 - 12/31/95
CONTRACT NUMBER FO9603-90-D-2217-SD02

DISTRIBUTION AUTHORIZATION: APPROVED FOR PUBLIC RELEASE;
DISTRIBUTION IS UNLIMITED

19960412 114

PREPARED FOR
OKLAHOMA CITY AIR LOGISTICS CENTER
TINKER AFB, OK 73145



... Putting Technology To Work

DTIC QUALITY INSPECTED 1

**ACCEPTABLE GLASS WINDOW/WINDSHIELD
REPAIR PROCESSES AND APPROVED VENDORS**

RICHARD J. OLSON

**BATTELLE
505 KING AVENUE
COLUMBUS, OH 43201**

FEBRUARY 1996

**MATERIAL AND PROCESS SPECIFICATION REPORT FOR 09/91 - 12/31/95
CONTRACT NUMBER FO9603-90-D-2217-SD02**

**DISTRIBUTION AUTHORIZATION: APPROVED FOR PUBLIC RELEASE;
DISTRIBUTION IS UNLIMITED**

**PREPARED FOR
OKLAHOMA CITY AIR LOGISTICS CENTER
TINKER AFB, OK 73145**

This report is a work prepared for the United States Government by Battelle. In no event shall either the United States Government or Battelle have any responsibility or liability for any consequences of any use, misuse, inability to use, or reliance upon the information contained herein, nor does either warrant or otherwise represent in any way the accuracy, adequacy, efficacy, or applicability of the contents hereof.

REPORT DOCUMENTATION PAGE			Form Approved OMB No. 0704-0188	
Public reporting burden for this collection of information is estimated to average 1 hour per response, including the time for reviewing instructions, searching existing data sources, gathering and maintaining the data needed, and completing and reviewing the collection of information. Send comments regarding this burden estimate or any other aspect of this collection of information, including suggestions for reducing this burden, to Washington Headquarters Services, Directorate for Information Operations and Reports, 1215 Jefferson Davis Highway, Suite 1204, Arlington, VA. 22202-4302, and to the Office of Management and Budget, Paperwork Reduction Project (0704-0188), Washington, DC 20503.				
1. AGENCY USE ONLY (Leave blank)	2. REPORT DATE February 1996	3. REPORT TYPE AND DATES COVERED Material and Process Specification Report, 9/01/91 - 12/31/95		
4. TITLE AND SUBTITLE Acceptable Glass Window/Windshield Repair Processes and Approved Vendors			5. FUNDING NUMBERS	
6. AUTHOR(S) Richard J. Olson				
7. PERFORMING ORGANIZATION NAME(S) AND ADDRESS(ES) Battelle 505 King Avenue Columbus, Ohio 43201-2693			8. PERFORMING ORGANIZATION REPORT NUMBER Contract FO9603-90-D-2217-SD02	
9. SPONSORING/MONITORING AGENCY NAME(S) AND ADDRESS(ES) Oklahoma City Air Logistics Center OC-ALC/TIET-R 3001 Staff Drive, Suite 2AG70A Tinker AFB, OK 73145-3040 Technology Transition Office AFMT TTO/TTP 2690 C, Suite 5 Wright-Patterson AFB, OH 45433-7412			10. SPONSORING/MONITORING AGENCY REPORT NUMBER VEP87CR52R1	
11. SUPPLEMENTARY NOTES				
12a. DISTRIBUTION/AVAILABILITY STATEMENT Approved for public release; distribution is unlimited			12b. DISTRIBUTION CODE	
13. ABSTRACT (Maximum 200 Words) To evaluate W/WS repair processes and vendors, used C/KC-135 and B-52 W/WS were repaired by a number of different vendors and then subjected to a series of tests to determine how they perform. The test results provide a basis for recommending repair processes and vendors. The test results indicate that repaired W/WS do not perform as well as new W/WS. The repaired W/WS showed deficiencies in an OEM inspection but performed acceptably in pressure/thermal cycle tests. They were decidedly inferior in bird impact performance, with one repaired W/WS failing catastrophically at test velocity. Recommendations for approved repair processes and vendors are contingent upon the Air Force deciding that the performance of repaired W/WS is acceptable. The data suggests that none of the four commercial repair vendors used in this program makes repairs that are either superior or inferior to the other vendors. Age and service history probably are the reasons that some W/WS perform better than others.				
14. SUBJECT TERMS Aircraft Transparencies, Windows/Windshields, Repair, C/KC-135, B-52, Bird Impact, Pressure/Thermal Cycling			15. NUMBER OF PAGES	
			16. PRICE CODE	
17. SECURITY CLASSIFICATION OF REPORT Unclassified	18. SECURITY CLASSIFICATION OF THIS PAGE Unclassified	19. SECURITY CLASSIFICATION OF ABSTRACT Unclassified	20. LIMITATION OF ABSTRACT Unlimited	

This page intentionally left blank.

TABLE OF CONTENTS

	<u>Page</u>
SUMMARY	viii
PREFACE	ix
1.0 INTRODUCTION	1
1.1 Background	1
1.2 Objective	1
1.3 Approach	1
1.4 Report Contents	1
2.0 GLASS W/WS	3
2.1 Construction	3
2.2 Damage	4
2.3 Repairs	6
3.0 W/WS REPAIRS MADE FOR THIS PROGRAM	8
3.1 Repair Vendors	8
3.1.1 NORDAM Transparency Division	8
3.1.2 Perkins Aircraft Services, Inc.	8
3.1.3 The Glass Doctor	9
3.1.4 PPG Industries, Inc. Aircraft Products Division	9
3.1.5 Pilkington Aerospace, Inc.	10
3.2 Program Prototype Repair W/WS	10
3.3 Vendor Selection	11
3.3.1 C/KC-135 W/WS	11
3.3.2 B-52 W/WS	11
3.4 Prototype Repairs	12
3.4.1 C/KC-135 W/WS	12
3.4.2 B-52 W/WS	12

TABLE OF CONTENTS (Continued)

	<u>Page</u>
4.0 REPAIRED W/WS STRUCTURAL INTEGRITY TESTING	13
4.1 Test Philosophy	13
4.2 Test Results	14
4.4 Summary	14
5.0 RECOMMENDATIONS FOR APPROVED GLASS W/WS REPAIR PROCESSES AND VENDORS	16
5.1 Discussion	16
5.2 Recommendations	17
5.3 Procurement of Services	18
6.0 REFERENCES	19

LIST OF FIGURES

Figure 2.1	C/KC-135 and B-52 W/WS General Construction	21
Figure 3.1	The Glass Doctor Patented Technique for Repair of Delaminations in Glass W/WS, U.S. Patent # 4,780,162	22
Figure 3.2	C/KC-135 W/WS Identification	23
Figure 3.3	B-52 W/WS Identification	24
Figure 4.1	Worst Delamination Observed in all Pressure/Thermal Cycle Tests (B-52 #2 W/WS, S/N 7-H-11-03-53)	25
Figure 4.2	Catastrophic W/WS Failure From a 4-Pound Bird Impact at 250 Knots (B-52 #1 W/WS, S/N 86-H-04-28-693)	26
Figure 4.3	Both Glass Plies Failure From a 4-Pound Bird Impact at 250 Knots (C/KC-135 #1 W/WS, S/N 83-H-11-21-325)	27
Figure 4.4	Broken Outboard Glass Ply Failure From a 4-Pound Bird Impact at 300 Knots (B-52 #2 W/WS, S/N 5-H-3-04-09)	28

LIST OF TABLES

Table 3.1	C/KC-135 W/WS Part Numbers	29
Table 3.2	B-52 W/WS Part Numbers	29
Table 3.3	C/KC-135 #1 W/WS Repairs	30
Table 3.4	C/KC-135 #4 W/WS Repairs	31
Table 3.5	B-52 #1 W/WS Repairs	32
Table 3.6	B-52 #2 W/WS Repairs	33

TABLE OF CONTENTS (Continued)

LIST OF TABLES (Continued)		<u>Page</u>
Table 3.7	B-52 Escape Hatch W/WS Repairs	34
Table 4.1	W/WS General Inspection Requirements	35
Table 4.2	Proof Pressure Test Conditions	35
Table 4.3	Cyclic Pressure Integrity Testing Schedule for C/KC-135 W/WS	36
Table 4.4	Cyclic Pressure Integrity Testing Schedule for B-52 #1 AND #2 W/WS	37
Table 4.5	Cyclic Pressure Integrity Testing Schedule for B-52 Escape Hatch W/WS	38
Table 4.6	C/KC-135 W/WS General Inspection Summary	39
Table 4.7	B-52 W/WS General Inspection Summary	40
Table 4.8	C/KC-135 W/WS Pressure Integrity Summary	41
Table 4.9	B-52 W/WS Pressure Integrity Summary	42
Table 4.10	C/KC-135 W/WS Bird Impact Test Summary (250 Knots, 4-Pound Bird)	43
Table 4.11	B-52 #1 W/WS Bird Impact Test Summary (4-Pound Bird)	44
Table 4.12	B-52 #2 W/WS Bird Impact Test Summary (4-Pound Bird)	45

SUMMARY

The Air Force, in trying to reduce fleet maintenance costs, is considering using repaired windows/windshields (W/WS). Based on reported cost savings and favorable experience that commercial fleets have had with repaired W/WS, the use of repaired W/WS seems very attractive. Prior to adopting an operating policy to use repaired W/WS, the Air Force decided that repair processes and vendors needed to be qualified.

The approach followed for evaluating W/WS repair processes and vendors was to procure some used C/KC-135 and B-52 W/WS, make repairs on them using a number of different vendors, and then subject the repaired W/WS to a series of tests to determine how they perform. The test results provide a basis for recommending repair processes and vendors.

The test results indicate that repaired W/WS do not perform as well as new W/WS. Many of the repaired W/WS still contain defects that would not pass an OEM quality assurance inspection. None of the W/WS tested, whether new, repaired, or not repaired, exhibited any dramatic differences in pressure integrity. Some delamination occurred in a few of the repaired W/WS during pressure cycling, but it was not severe. Delamination was also observed in the new B-52 W/WS.

The most demanding structural test is the bird impact. C/KC-135 #1 and #4 W/WS were bird impact tested at 250 knots. B-52 #1 W/WS were tested at 250 knots, while B-52 #2 W/WS were tested at 300 knots. The bird impact test results are quite clear - the new W/WS outperform either repaired or unrepaired W/WS. Some of the repaired and unrepaired W/WS showed no evidence of damage. Others, however, failed catastrophically allowing the bird to enter the cockpit.

Recommendations for approved repair processes and vendors that can be made as a result of the work performed on this program are contingent upon the Air Force making a decision that the performance of repaired W/WS is acceptable. The available data suggests that none of the four commercial repair vendors used in this program makes repairs that are either superior or inferior to the other vendors. The processes used by the vendors, for the most part, are very similar. Thus, it is not surprising that the repaired W/WS all perform about the same. Age and service history probably are the reasons that some W/WS perform better than others.

PREFACE

The work reported herein was performed by Battelle, Columbus, Ohio, under Air Force Contract FO9603-90-D-2217-SD02, "Development of Repair Processes and Sources for C/KC-135 and B-52 Aircraft Windows/Windshields". The program was directed by the Oklahoma City Air Logistics Center (OC-ALC) at Tinker Air Force Base. Air Force administrative direction was provided by Ms. Cindy Cooper, OC-ALC/LADCB. Air Force technical direction was provided by Mr. Robert Koger, OC-ALC/TIETR.

The work was performed during the period of September 1991 to December 1995. The technical program at Battelle was directed by Mr. Richard Olson of Battelle's Engineering Mechanics Department. The author wishes to acknowledge Mr. Russ Corsi of PPG Industries, Inc. Aircraft Products Division in Huntsville, Alabama; Mr. Dick Forler and Mr. John Kollar at The Glass Doctor in St. Petersburg, Florida; Mr. Marc Overton at NORDAM Transparency Division in Tulsa, Oklahoma; and Mr. Andy Cuperi at Perkins Aircraft Services, Inc. in Ft. Worth, Texas, for their help in getting W/WS repairs made: Mr. Wayne Fisher, Mr. Jim Hood, and Mr. Herb Goodrich of PPG Industries, Inc. Aircraft Products Division in Huntsville, Alabama for their conscientious effort in performing the W/WS testing: and Mrs. Verna Kreachbaum at Battelle for her efforts in preparing the manuscript.

1.0 INTRODUCTION

1.1 Background

Many commercial airlines currently use repaired glass cockpit windows/windshields (W/WS) to reduce their operating costs. For commercial fleets, W/WS represent the fifth highest airplane operating expense, behind engines, fuel, tires, and brakes. Because the cost of repairing a cockpit W/WS can be substantially less than the purchase price of a new W/WS, there is an incentive to use repaired W/WS. The repairs are performed by a number of different U.S. Federal Aviation Authority (FAA)-approved vendors.

The U.S. Air Force (USAF) has not joined the commercial fleets in endorsing the use of repaired W/WS. With decreasing Congressional funding for the military, however, measures to reduce fleet operating costs are receiving greater scrutiny. Thus, the use of repaired W/WS is being given serious consideration.

In September 1991, the Air Force contracted with Battelle to investigate the feasibility of using repaired glass cockpit W/WS. During the course of this study, W/WS were repaired at several commercial repair vendors and then tested. This report summarizes the test results and specifies the acceptable repair processes and repair vendors.

1.2 Objective

The objective of the work reported herein is to catalog the repairs made to two sets of glass military aircraft cockpit W/WS, to summarize the results of tests conducted on the repaired W/WS, and from the results of the tests, specify acceptable repair processes and repair vendors.

1.3 Approach

Glass cockpit W/WS removed from C/KC-135 and B-52 aircraft were sent to commercial repair vendors for refurbishment. The repaired W/WS were then inspected for conformance with OEM W/WS specifications and then subjected to pressure/thermal cycle tests and bird impact tests to see how they perform. The test data was used to determine the acceptability of repair processes.

1.4 Report Contents

The results of this study are presented in the sections that follow. Topics presented include:

- A review of glass cockpit W/WS construction and damage
- A discussion about the selection and repair of W/WS in this program

- A summary of the W/WS test results
- Process and vendor recommendations.

2.0 GLASS W/WS

2.1 Construction

To provide a context for discussing W/WS repairs, it is important to understand the construction of glass cockpit W/WS. For the purposes of this report, C/KC-135 and B-52 glass cockpit W/WS will be used as the basis for the discussions.

Figure 2.1 shows the general construction of the glass C/KC-135 and B-52 W/WS. The W/WS have a three-part glass and vinyl laminate construction. The inner layer is thick, heat-strengthened plate glass designed to withstand cabin pressure forces. A transparent, plasticized, polyvinyl butyral core layer acts as the "fail-safe" load carrying member and prevents shattering in the event of inner ply failure. The outer ply is a relatively thin layer of heat-strengthened glass with no structural significance, but it provides rigidity and a scratch-resistant surface. A phenolic or masonite filler strip, located around the edge of the W/WS, and a metal filler strip embedded in the vinyl provide the means to attach the W/WS to the airframe. Vinyl or vinyl and rubber bumpers protect the edges of the glass plies.

The structural integrity design of C/KC-135 and B-52 cockpit W/WS is based on two requirements: "fail-safe" pressure integrity and bird impact resistance. The "fail-safe" pressure integrity is founded on two redundant systems, an inner glass ply that can sustain the full rated cabin pressure in the absence of all other layers, and a polymeric core ply that can maintain pressure integrity if the inner and outer glass plies are cracked. The bird impact structural integrity of W/WS is either characterized as "bird bagging" or "bird bounce." Bird bagging W/WS are typically two glass layers with a polymeric core ply. Bird penetration is stopped by large ductile deformation of the core ply, i.e., "bagging" the bird. Bird bounce W/WS are typically multi-laminates and cause the bird to "bounce" off the W/WS. The C/KC-135 and B-52 W/WS cockpit W/WS are "bird bagging" W/WS.

The glass used in C/KC-135 and B-52 W/WS is heat strengthened to provide resistance to cracking. The glass is heated to near the softening point and then quenched to produce compressive residual stresses that extend from the outer surface into a depth of about 1/6th of the glass thickness. Below the compressive stress layer lies tensile residual stresses. As long as surface defects do not penetrate into the tensile layer, the glass will exhibit a high resistance to fracture. However, once a crack does fully penetrate the tensile layer, the glass will shatter as the tensile stresses are relieved.

The vinyl core, which acts as the "fail-safe" pressure boundary and means for controlling glass fragments in the event of a glass ply failure, is highly plasticized polyvinyl butyral. The vinyl is relatively brittle at low temperatures (-65° F), and unable to absorb much energy per unit volume. At temperatures approaching 130° F, the vinyl becomes very ductile and can absorb a relatively large amount of energy as it is loaded. W/WS heaters, which not only de-fog and de-ice the glass, ensure that the vinyl remains ductile.

An integral part of the C/KC-135 and B-52 W/WS construction is slip planes or a parting medium at the edges of the glass. A slip plane is located between both the inner glass ply and the vinyl and the outer glass ply and the vinyl as shown in Figure 2.1. The slip planes are thin strips of material at the glass-vinyl interface that keep the glass from bonding to the

vinyl. This allows the various plies to move independently at these locations in response to pressure loads and differential thermal expansion. Without the slip planes, the glass at the edges of the W/WS would be prone to fracture because it would exceed its strain limit as it tried to move with the underlying vinyl. The slip planes form a "softer" connection that promotes a more gradual build up of strains in the glass so that it does not exceed its strain capacity. Although the slip planes look similar to delamination, they are not defects but an intentional part of the W/WS design.

The C/KC-135 and B-52 cockpit W/WS contain heating systems for anti-icing and/or anti-fogging. An electrically conductive film of pyrolytic tin oxide between the outer glass ply and the vinyl core ply is used to heat C/KC-135 and B-52 W/WS to reduce ice/frost formation. A similar conductive film between the inner ply and core ply is used on some W/WS for defogging only. The W/WS heating system, so called NESAS[®] coated glass, uses the resistivity of the film to provide the heating. A few of the C/KC-135 W/WS also contain fine wires at the W/WS edges between the outer glass ply and vinyl, so-called edge heaters, to correct a heating power deficiency in the corners. The temperature of some W/WS is controlled with an integral sensor embedded in the laminate. Externally applied thermal switches control the temperature on other W/WS.

Seals on the W/WS keep cabin pressure in and moisture out. In addition, they act as vibration and shock absorbers and help to compensate for differential thermal expansion between the W/WS and the airframe. The C/KC-135 W/WS utilize a silicone rubber molded-in-place pressure seal that is molded to the W/WS mounting surface. A few of the molded-in-place seals have a stainless steel z-channel sandwiched between a silicon rubber cushion and the beaded pressure seal. The B-52 W/WS use either molded-in-place seals or pre-made polysulfide rubber seals that are glued onto the W/WS frame with polysulfide rubber. All of the C/KC-135 and B-52 W/WS, except the B-52 escape hatch W/WS, mount from the inside of the aircraft. Drawing the W/WS tight to the airframe with mounting bolts effects the seal.

Many of the W/WS on the C/KC-135 and B-52 are flat. The W/WS directly in front of the pilot fall into this category. Because they are flat, they are easy to manufacture and repair. In addition, they have very good optics. Several of the C/KC-135 and B-52 W/WS are curved. Some of them have a single axis of curvature, while others have compound curvature. The curvature tends to result in some degree of optical distortion, and the curvature makes it somewhat more difficult than flat W/WS to repair, in spite of the fact that the curved W/WS are generally smaller than the flat ones.

2.2 Damage

The most common failure modes of laminated glass transparencies are:

- Delamination: separation of vinyl from the glass
- Cracks and chipping: glass breakage due to high stress
- Arcing: unbalanced electrical potential within the conductive coating

- Heater Failure: loss of continuity in the heater or sensor circuit or low power
- Impaired Vision: due to surface scratches, contaminates, or internal defects
- Contamination: air or water leaks caused by defective seals
- Vinyl cracking.

Delamination is separation of the glass surface of the inner or outer ply from the vinyl core ply to which it is bonded. Delamination generally starts at the slip planes and moves inward, although it may occur anywhere in the W/WS. It mainly occurs between the outer ply and the vinyl ply. Delamination does not dramatically reduce the strength of the W/WS, but may interfere with vision or W/WS heating if the delamination occurs at the interface where the heating film is located.

Cracks and chips may occur in either of the glass plies and may be caused by impacts or by high stresses at the edges of the glass. Single cracks in the outer ply are unlikely because the temper in this layer precludes a single crack. After the momentary appearance of a crack in the outer layer, the entire layer shatters very abruptly. Small cracks very near the edges of the W/WS may not be cause for removal, provided the crack is not directed toward the center of the pane. Cracks that adversely affect the functioning of the heater would not be acceptable. Chips may occur internally or externally. Internal chips are caused by the glass-vinyl bond strength exceeding the strength of the glass. External chips are generally caused by impacts. Chips usually have a clamshell shape, are rough, and white powdered glass is often in evidence. Chips are detrimental to the strength of the pane.

W/WS busbar breakdown and faults in the heater film cause arcing. Basically, the insulation breaks down and the heater electrical current short circuits to the airframe. Arcing is evidenced by burned areas around electrical braid and along the busbar.

The failure of the W/WS heater to de-ice or defog satisfactorily is one of the most serious failure modes. Arcing, chips, cracks, or lack of continuity in the heater film that render the heater inoperative are cause for W/WS replacement. Uneven heating or hot spots caused by delamination at the glass-vinyl interface with the heating film or chips may also be a cause for removal. As W/WS age, the resistance of the heater generally rises. In order to provide the same power for defogging or de-icing, the voltage applied to the W/WS must be increased. At the maximum possible voltage (which is governed by the design of the W/WS autotransformer and the current carrying capacity of the wiring to the W/WS), if the W/WS heater resistance is above allowable specifications, the heater will be perceived as being ineffective.

Satisfactory optical properties of the W/WS are paramount. Foggy or cloudy areas may appear in places where moisture has penetrated the vinyl and has begun to degrade it. Scratches may occur on both the inner and outer plies that may interfere with visibility. Likewise, delamination may become serious enough to warrant replacement of the W/WS on the basis of reduced visibility. Bubbles may occur in the vinyl core ply in W/WS that have been exposed to elevated temperatures. Bubbles are caused by gas liberated from the vinyl,

and grow in size and number with increased temperature or longer exposures. Needless operation of the heaters on the ground is a prime cause of bubbles. Bubbles do not have a large effect on strength of the W/WS, but may become serious enough to impair visibility. Although other failure modes may not be evident, poor optical performance is always a sufficient cause for W/WS replacement.

The bumpers on the edges of the glass form a moisture barrier. Degradation of bumpers in the form of cracking or separation from the edge of the glass ply can allow moisture and air to get into the slip planes. Moisture can degrade the heater film with consequent initiation of heater failure, arcing, delamination, and contamination.

As a result of aging, cracks may occur in the vinyl. Over time, attack by ultraviolet radiation and high temperatures also causes the vinyl to lose ductility. Eventually, cracks may form around the periphery of the W/WS in proximity to the metal insert as the glass and vinyl try to move relative to one another. Vinyl cracks significantly weaken the structure of the W/WS by putting flaws directly in the load path between the transparency and the airframe for bird impact loads. Per Figure 2.1, only the vinyl extends out to the mounting holes, not the glass. Therefore, if the vinyl is cracked near the metal insert, the W/WS could just "punch out" of the frame into the cabin in a bird impact situation. The vinyl layer is also the pressure "fail-safe" layer, so vinyl cracks are quite important.

In addition to cracking, the vinyl layer may discolor or darken if it is subjected to temperatures in excess of 225° F. Foreign substances in the glass-vinyl interface, either from in-service conditions or introduced as a part of a repair process, may also cause discoloration.

2.3 Repairs

The manufacture of a new W/WS is conceptually quite simple - two layers of glass are bonded together with vinyl under heat and pressure to form an optically acceptable transparency. Likewise repairing a damaged W/WS is also conceptually simple - rebond separated laminates, and remove unacceptable scratches, chips, and cracks. Unfortunately, although the concept of manufacturing a new W/WS or repairing a damaged one is quite simple, the implementation requires a great deal of "art" and practice to become skilled at making successful repairs.

Economical glass cockpit W/WS repairs are generally limited to the exterior surfaces that are accessible without disassembling the windshields. In exceptional cases, when the cost of a new W/WS is high, W/WS can be disassembled for repair by separating the glass and vinyl layers.

W/WS repairs can be conveniently divided into four categories:

- 1) Electrical heater system repairs

The opportunity to repair heater problems is limited. Out-of-specification bus resistance, the biggest heater system problem, cannot be repaired. Sensor failure, the second largest heater system problem, can be repaired by potting a new sensor into the vinyl. Corrosion can always be removed from terminals.

2) Delamination

Delamination is usually removed by pressing the W/WS in an autoclave at elevated temperature. Delamination repairs can also be made by injecting clear adhesive into voids around the edge of a W/WS.

3) Surface defects

Scratches and/or pits on the surfaces of transparencies are removed by polishing with sheet abrasives or rare-earth-compound abrasive slurries. In general, polishing is done manually and its success is dependent upon operator skill.

4) Seals and bumpers.

The rubber seals and bumpers around the periphery of transparencies are repaired by scraping the old material off and either casting new material in place or else gluing on pre-made seals.

3.0 W/WS REPAIRS MADE FOR THIS PROGRAM

There currently are five prominent commercial aircraft W/WS repair stations: NORDAM Transparency Division; Perkins Aircraft Services, Inc.; The Glass Doctor; PPG Industries, Inc. Aircraft Products Division; and Pilkington Aerospace, Inc. Each of these companies has developed the necessary techniques and skills to become an FAA-certified W/WS repair station. In all cases, the concepts involved in their repair processes are as simple as described above. The actual reduction to practice of the concepts, however, is either treated as a trade secret or is covered by patents.

3.1 Repair Vendors

3.1.1 NORDAM Transparency Division

NORDAM Transparency Division is one of the world's largest privately held, FAA-approved transparency repair stations, providing comprehensive overhaul capabilities on glass and acrylic W/WS. Located in Tulsa, Oklahoma, NORDAM has more than 15 years experience in the repair and overhaul of aircraft W/WS.

Repairs that NORDAM is authorized to make include relaminating, surface polishing, and seal rehabilitation. Autoclave curing of delamination, bubbles, voids and interlayer vinyl cracking is done with the same laminating cycles, times and methods utilized in the original manufacture of the W/WS. Polishing includes removal of scratches, chips and pits from the outer glass or acrylic and inner plies. Original optimum optics are restored with the least amount of surface material removal, in accordance with strict adherence to OEM manual limits for removal. Seal rehabilitation includes cleaning, repairing, or replacing of seals as required. NORDAM is authorized by the FAA under Air Agency Certificate EZ22812K to make the W/WS repairs.

3.1.2 Perkins Aircraft Services, Inc.

Perkins Aircraft Services, Inc. specializes in the overhaul and repair of both monolithic and laminated aircraft transparencies made of glass or acrylic. Located in Ft. Worth, Texas, Perkins is an FAA-approved repair facility authorized to make in-plant and "on the aircraft" repairs.

A five-step process is used by Perkins to restore damaged W/WS to an FAA-serviceable condition. First, all incoming W/WS are given a thorough inspection to determine whether the W/WS can be repaired. W/WS with out-of-specification electrical systems or that are otherwise judged unrepairable are rejected and returned. The second step of the process is repair of delamination. Using a proprietary autoclave process, the W/WS are heated and pressed to rebond the W/WS layers. Polishing, the third step in the W/WS repair process, is done to remove scratches, chips, and in the case of plastic W/WS, crazing, using automated polishing machines. The fourth step is reassembly. In this step, the transparencies are matched up to their original frames, as applicable, and seals and gaskets are replaced. The

final step in Perkins' W/WS repair process is to perform a quality assurance inspection to ensure that all of the necessary repairs have been made and that the W/WS has been restored to OEM specifications. Perkins holds FAA Air Agency Certificate JKQR257L which authorizes them to operate their W/WS repair station.

3.1.3 The Glass Doctor

The Glass Doctor of St. Petersburg, Florida got into the aircraft transparency repair business in 1979 after working in the automobile windshield repair business for 10 years. Starting with cabin window repairs, the business has expanded to also include FAA-approved repair of all cockpit W/WS as well as cabin windows.

The Glass Doctor has developed special techniques for repairing chips, nicks, and delaminations in W/WS. Unlike the other aircraft W/WS repair vendors, The Glass Doctor does not rely solely upon polishing and re-autoclaving of the W/WS to effect the repairs. As described in U.S. patent #4,780,162^[1], The Glass Doctor repairs delaminations by injecting an adhesive between the delaminated plies per Figure 3.1. Conventional autoclave relamination and polishing for scratch and distortion removal is also done.

Using experience gained from their delamination repair techniques, The Glass Doctor has also developed the unique capability to replace failed W/WS heater sensors and can repair open or arcing busbars. Failed heater sensors are replaced by drilling into the vinyl and potting a new sensor in the hole. Open or arcing busbars are repaired by injecting a conductive adhesive material at the glass-vinyl interface where the busbar defect is located. Although there is some controversy in the aircraft W/WS repair industry associated with the repairs that The Glass Doctor makes, repairs are under warranty for up to 3 years (scratches excluded), and the reported rate of warranty work is very low. The Glass Doctor operates its W/WS repair station under FAA Air Agency Certificate OX4R430M.

3.1.4 PPG Industries, Inc. Aircraft Products Division

PPG's Aircraft Products Division, located in Huntsville, Alabama, has been in the aircraft transparency business since 1926 and is an OEM supplier for C/KC-135 and B-52 W/WS, as well as many other military, commercial, and general aviation aircraft W/WS. The Huntsville plant is America's largest and most modern facility for producing aircraft transparencies. It fabricates W/WS with heat strengthened and chemically tempered glasses, as-cast and stretched acrylics, and polycarbonates for commercial, military, and general aviation aircraft. The W/WS repair services that PPG offers include scratch removal, gasket and seal rehabilitation, relamination, upgrade to the latest revision, and replacement of broken outer plies for all glass-faced Boeing and Douglas W/WS that were originally manufactured by PPG. PPG warranties the revision level upgrade and ply replacement for 36 months, while other repairs are warranted for 12 months. The PPG W/WS repair facility has been in operation since May 1994, and is operated under FAA Air Agency Certificate IL4R262M.

3.1.5 Pilkington Aerospace, Inc.

Pilkington Aerospace of Garden Grove, California, is the combined organization of Swedlow, Inc. and Triplex Aircraft & Special Products Limited, operating as a fully owned subsidiary of Pilkington plc., the world's largest producer of glass and allied products. Pilkington is an OEM for: 1) Commercial transport aircraft glass frontal W/WS, plastic and glass-plastic composite side W/WS, and stretched acrylic cabin W/WS, 2) Military aircraft W/WS including free-formed stretched acrylic and laminated canopies, as well as transport aircraft glass front W/WS, and 3) Commuter and rotary wing aircraft stretched acrylic, glass-polycarbonate laminate, and glass-PVB laminate W/WS. Pilkington is authorized to repair W/WS for all models of Boeing, Douglas, Airbus, Saab, Lockheed, Fairchild, and British Aerospace aircraft. Repairs include scratch removal, relamination, and replacement of the front ply on glass-laminate W/WS. Pilkington's repair facility is operated under FAA Air Agency Certificate P9AR279J.

3.2 Program Prototype Repair W/WS

W/WS from two different aircraft were used in the program to evaluate repair processes. At the beginning of the program, repairs were made on C/KC-135 W/WS. Subsequently, a decision was made to expand the scope of the program to include B-52 W/WS.

The C/KC-135 has 10 cockpit W/WS identified in Figure 3.2, 5 on the pilot side and 5 on the copilot side. The set of five W/WS on the copilot side are a mirror image of the pilot side W/WS. W/WS #1 is the forward W/WS, #2 and #3 are side W/WS, and #4 and #5 are eyebrow W/WS. All of the W/WS except #2 are fixed-position W/WS. W/WS #2 opens to provide ventilation and ground communication by sliding aft on a track. Table 3.1 lists the current part numbers for C/KC-135 W/WS.

The B-52 has 13 cockpit W/WS, a front center one and six on each side of the aircraft. The #3 W/WS on each side of the B-52 can slide on a track. Figure 3.3 shows the location and numbering scheme for the B-52 W/WS. Unlike the C/KC-135, all B-52 W/WS are not glass; the #6 W/WS is made of stretched acrylic plastic. Table 3.2 lists the current W/WS part numbers for the B-52.

OC-ALC made arrangements to have 75 C/KC-135 W/WS that were removed from fleet aircraft at Tinker AFB shipped to Battelle as prototype repair candidates. Over 100 W/WS were screened to find the 75 prototype repair candidates. At the time of their removal, the W/WS were judged not serviceable per the criteria of the applicable C/KC-135 Fuselage Window Tech Order^[2]. Indicated reasons for removal from service included: failed heaters, bubbles, scratches, separation, leaks, old, discolored, and corrosion. The set of 75 consisted of a mixture of #1 through #5 pilot-side and copilot-side W/WS.

OC-ALC supplied 118 B-52 W/WS to Battelle by having them removed from retired aircraft at AMARC. The W/WS consisted of pilot-side and copilot-side #1, #2, and escape hatch W/WS. Unlike the C/KC-135 W/WS, the B-52 W/WS were not removed from the flight line for cause. Rather, they were taken from retired aircraft that had been on active duty.

After the B-52 W/WS were removed from the aircraft and shipped to Battelle, the W/WS were evaluated to see if they were suitable for repair. In spite of the fact that the W/WS had not been removed for cause and were on previously active duty aircraft, 67 of the W/WS were found to be out of specification on heater or sensor resistance, or else the glass was chipped. The unreparable W/WS were destroyed and the remaining 51 formed the pool from which repair candidates were selected.

The service history of the prototype repair candidates is not known because: 1) very few of the W/WS had airframe numbers, 2) the Air Force does not track W/WS by serial number, and 3) planes are moved from location to location as a part of normal squadron rotation. In most instances, the date of removal from service was not noted. The installation date is not known for any of the W/WS. All that is known for certain is the year the W/WS was made; the first one or two digits of the serial number indicate the year the W/WS was made - a single digit is a 1970's vintage W/WS.

3.3 Vendor Selection

The W/WS repair vendors used in this program were paid for their services. The repairs were made at the vendors' prevailing commercial rates, with vendors selected by competitive bid. Vendors were given descriptions of the condition of W/WS to be repaired and then asked to give rough estimates of the costs to repair a fixed number of the different W/WS on an aircraft. In the case of the C/KC-135 W/WS, all of the vendors had a good idea of what they were getting into, based on their experiences with commercial Boeing 707 W/WS. For the B-52 W/WS, none of the vendors had any direct experience making B-52 W/WS repairs. To provide repair estimates for the B-52 W/WS, they extrapolated from their experience with other W/WS. Repair specifications for the B-52 W/WS were provided to the vendors by Battelle and came from the B-52 Technical Orders^[3], W/WS drawings^[4-6], and W/WS OEM design specifications^[7-9].

3.3.1 C/KC-135 W/WS

Quotations for repairing C/KC-135 W/WS were solicited in October 1991 from NORDAM, Perkins, and The Glass Doctor. Terms and conditions for a site visit and repair of a number of W/WS were successfully negotiated with NORDAM and Perkins

The set of 75 C/KC-135 W/WS was divided, and half sent to NORDAM and half sent to Perkins. Each vendor evaluated the reparability of the W/WS that they were sent and provided a quotation for repairing each W/WS. In conjunction with Battelle engineers, a subset of the 75 W/WS was selected for repair. Perkins repaired 7 #1 W/WS and 2 #4 W/WS. NORDAM repaired 8 #1's and 8 #4's.

3.3.2 B-52 W/WS

Quotations for repairing B-52 W/WS were solicited in August 1994 from NORDAM, Perkins, The Glass Doctor, PPG, and Pilkington. Contracts for making repairs were negotiated with The Glass Doctor and PPG.

The Glass Doctor and PPG were each sent 7 #1, 7 #2, and 3 escape hatch W/WS for repair. From the W/WS sent, each vendor was to repair 4 #1, 4 #2, and 2 escape hatch W/WS, as mutually selected by Battelle and the vendor. PPG repaired the contracted number. The Glass Doctor repaired all of the W/WS sent to them (17) for the contracted price of 10.

3.4 Prototype Repairs

3.4.1 C/KC-135 W/WS

Tables 3.3 and 3.4 provide details of the prototype repairs made to the #1 and #4 C/KC-135 W/WS that were subsequently tested. W/WS that have serial numbers that begin with numbers were made by PPG, while those that start with letters were made by Libbey-Owens-Ford. In several instances, there were discrepancies between serial numbers that were recorded during inspections by various parties. These serial numbers are noted with question marks.

To fill out the test matrix, unrepaired W/WS were included in the test program, one #1 and six #4's. The original intent was to have a balanced number of repairs from each vendor and a balance in the types of repairs made. Unfortunately, it did not work out this way, because Perkins got a disproportionately large number of unrepairable W/WS. Because the performance of unrepaired W/WS provides a baseline for as-removed condition, including them in the test matrix was useful.

3.4.2 B-52 W/WS

Tables 3.5 through 3.7 provide the details of the condition of the repair prototype B-52 W/WS and the subsequent repairs that were made to them. In the list, two items are worthy of special mention. First, The Glass Doctor made delamination repairs on the W/WS by injecting clear adhesive into the W/WS. Second, on one #1 and one #2 W/WS, The Glass Doctor did a sensor replacement.

4.0 REPAIRED W/WS STRUCTURAL INTEGRITY TESTING

4.1 Test Philosophy

The test plan was developed as a joint effort between Battelle, OC-ALC, and the Flight Dynamics Laboratory at Wright-Patterson AFB. The Air Force does not own the Boeing 707 airframe design on which the C/KC-135 is based, so they do not have W/WS drawings and the W/WS design specifications or W/WS vendor qualification test protocols. For the B-52, the Air Force owns the design and thus has drawings and all W/WS design and test specifications. Upon reviewing the available B-52 W/WS information, it became clear that the B-52 W/WS design predates specification of anything but pressure load integrity. Thus, the B-52 specifications were only of limited value. The test plan, therefore, was developed from the C/KC-135 and B-52 Technical Orders and the open literature on W/WS testing^[10-11].

In order to assess whether the performance of the repaired W/WS is satisfactory, a standard for comparison must be defined. Obviously, the performance of new W/WS should be the basis for the comparison. Simply stated, the repaired W/WS should, ideally, perform just like new W/WS. In the best situation, information for new W/WS would be available to define the required tests for the repaired W/WS and the existing new W/WS data would form the basis for the comparisons. The information available from Boeing and OC-ALC suggested that data on prior C/KC-135 and B-52 W/WS testing was sparse or very difficult to retrieve, so the scope of the testing program had to include tests of new W/WS to generate the baseline new W/WS performance data. In addition, because of uncertainty in setting some of the parameters for the tests (load levels, primarily), the test program included a methodology phase verification to establish that the new W/WS would pass the tests. Although testing of new W/WS was primarily a response to the lack of readily available new W/WS test data, it does facilitate the process of making the comparisons because both new and repaired W/WS were tested under absolutely identical conditions.

The test plan required facilities for general W/WS optical/electrical/mechanical inspection, pressure and thermal cycling, and bird impact testing. To fulfill the testing requirement, an outside vendor, PPG Industries, Inc. Aircraft Products Division was subcontracted to do the testing, based on competitive bidding.

PPG's Aircraft Products Division, located in Huntsville, Alabama, has been in the aircraft transparency business since 1926 and is an OEM supplier for C/KC-135 and B-52 W/WS. As a leader in the field of aircraft transparency technology, PPG has built an impressive W/WS qualification testing facility. PPG's testing capabilities include bird impact testing, environmental testing, high strain rate material evaluation, dynamic deflection analysis with high speed photography, dynamic stress analysis with strain gages, and ballistic testing for transparent armor. In performing the tests for this program, PPG used the same test fixtures, test procedures, and QA requirements in use today to make new W/WS for C/KC-135's and B-52's. These capabilities at a single site, coupled with their intimate knowledge of the C/KC-135 and B-52 W/WS proved valuable to this program.

4.2 Test Results

Three major types of tests were conducted on the repaired prototype W/WS and the companion new W/WS:

- A thorough visual/electrical/optical inspection
- Pressure/thermal cycles
- Bird impact testing.

Tables 4.1 through 4.5 summarize the conditions for the various tests. The repaired prototypes and new W/WS were all given the inspections and then a fraction of the W/WS was subjected to each of the other two types of tests. Complete details of the testing can be found in References 10 and 11.

Tables 4.6 and 4.7 summarize the results of the general inspections. In a number of areas, the repaired W/WS are the equivalent of new W/WS. There are, however, some troublesome areas - seals, unremoved delaminations, residual scratches, some insulation integrity faults, and a few out of specification heater resistances that suggest that the repaired W/WS are not up to OEM standards for a new W/WS.

The results of the pressure integrity testing are summarized in Tables 4.8 and 4.9. None of the W/WS, repaired, not repaired, or new, exhibited any catastrophic failures. Some of the repaired W/WS did experience delaminations, and evidence of delamination was detected in the new B-52 W/WS. Figure 4.1 shows the worst delamination that occurred in any of the W/WS tested. In this figure, the edge of the delamination has been outlined with a black marker. None of the W/WS exhibited delamination that would cause the pilot to be unable to see through the W/WS.

A summary of the bird impact test results is presented in Tables 4.10 through 4.12. A gradation in impact damage is shown in Figures 4.2 to Figure 4.4, ranging from catastrophic failure to only a broken front ply. Other W/WS with similar damage look about the same as these figures.

4.3 Summary

From the data presented, the obvious conclusion is that used W/WS do not perform as well as new W/WS. Although trends are difficult to identify in the data because there always seem to be exceptions and because the data base is so small, the performance of W/WS that have been in service, whether repaired or not, is below that of new W/WS.

In a number of categories, the repaired W/WS were the equal of new W/WS: dimensional fit, most optical properties, and heater performance. In other cases, they were not: residual delamination and scratches, seals and bumpers, delamination during pressure cycling, more damage in the ball drop test, and poorer performance in the bird impact testing. Some of the issues such as seal and bumper problems and residual delamination can easily be

rectified. The delamination during pressure cycling is merely annoying because it is an impaired vision issue that would develop over time and is not a serious structural failure.

The bird impact test results are problematic. The new W/WS performed significantly better than the repaired and not repaired W/WS. At worst, the outboard ply of new W/WS were broken. For the repaired C/KC-135 #1 W/WS, fully half of the samples had all three plies fail, although none had bird penetrations. For the repaired C/KC-135 #4 W/WS, only an outboard ply was broken. The unrepaired C/KC-135 #4 W/WS performed the worst in the bird impact tests, with one whole W/WS punching out of the frame. This W/WS was rejected for repair, but it appears that it was for an out-of-specification heater and not for any unreparable structural deficiency. Similarly, the other two unrepaired C/KC-135 #4 W/WS that were damaged were also rejected for out-of-specification heaters. The fact that repaired W/WS performed somewhat better than unrepaired W/WS seems to indicate that the repairs themselves do not degrade the W/WS.

The B-52 W/WS bird impact tests showed some alarming results. First, the target 400 knot impact velocity could not be reached. If there are B-52 missions that call for low-level high-speed flight above 250 knots, there is a risk of a bird impact catastrophically failing a W/WS and perhaps initiating a crash. Second, one of the repaired W/WS failed catastrophically at the test velocity. This either suggests that the velocity to be bird impact "safe" using repaired W/WS is lower than the test velocity or else there is a higher bird impact damage risk when using repaired W/WS.

Reviewing the data, there is no indication that the repairs made by any one of the vendors used in this program is either superior or inferior to the repairs made by the other vendors. All of the vendors had W/WS that did not pass one or more parts of the OEM inspections. It is troublesome that some of the W/WS that were repaired did not meet resistance specifications - these W/WS should have been culled out by the repair vendors. Deficiencies related to seals and bumpers, although annoying, is a problem that can easily be corrected with a QA program. Although the database is very limited, the bird impact and pressure cycling results appear to be independent of the repair vendor.

5.0 RECOMMENDATIONS FOR APPROVED GLASS W/WS REPAIR PROCESSES AND VENDORS

5.1 Discussion

Perkins, NORDAM, and PPG use virtually identical processes to repair glass aircraft W/WS: re-autoclaving and polishing. The Glass Doctor substitutes adhesive injection for re-autoclaving. All of the repair vendors do similar seal and bumper rehabilitation. The Glass Doctor also performs sensor replacement. Aside from the adhesive injection and sensor replacement, there is little to distinguish the repair processes of one vendor from another.

Concerning the performance of repaired W/W, the overall performance of repaired W/WS is below that of new W/WS. Two possible reasons for repaired W/WS to perform below new W/WS are: 1) Degradation of the W/WS due to age, and 2) The repair processes have somehow affected the W/WS. Four factors related to these two reasons have been identified:

- Vinyl degradation - Vinyl, being a plastic is subject to UV degradation and general aging due to loss of plasticizer. As a result of the aging, the vinyl may become brittle and crack, thus reducing its load carrying capacity in the laminate. The vinyl could also be preferentially squeezed from the edge of the W/WS during a relaminating repair process or in service. Because the vinyl is the only structural ply that carries the load into the W/WS frame, if this occurred, the load capacity of the W/WS would be degraded.
- Grinding/polishing of the glass - The C/KC-135 and B-52 W/WS use heat-strengthened glass. In producing this type of glass, the ply is heated to near its softening point and then quenched to introduce compressive residual stresses in the surface layers. Tensile stresses inside the glass exist to equilibrate the compressive surface stresses. Because glass only fails due to tensile stresses at the surface, the residual compressive stresses must be overcome to initiate a failure. Grinding and polishing remove some of the beneficial compressive stresses, and hence, the overall strength of the glass ply is reduced. Removal of the highest compressive stress layer, however, must be balanced against removal of flaws. In concert with the obvious effect of removal of the highest compressive stress layer, as far as flaw tolerance goes, the surface may also not be as smooth after grinding/polishing. Smoother surfaces have less flaws and a profoundly higher strength^[12].
- Stress corrosion cracking of the glass - The surface of glass contains many microscopic cracks and fissures, and under a sustained load, the presence of moisture exacerbates the growth of these cracks^[13-16]. Generally, water vapor in the air is sufficient to cause the degradation. Elevated temperatures and longer exposures accelerate the stress corrosion cracking effect. Although there is no

direct evidence that aircraft W/WS degrade dramatically from this phenomenon, the fact that the W/WS are highly stressed due to thermal and pressure loading, they are exposed to atmospheric moisture, they are routinely heated in a high stress state, and that old W/WS performed below new W/WS in the structural tests suggests that there may be more than a casual cause-effect relationship.

- Fatigue - Glass exhibits a complex load rate-cyclic loading behavior. Under a constant maximum load, no effect of cyclic loading is observed, but under increasing maximum load, cyclic loading reduces the strength^{17,18}. The net effect for a W/WS undergoing repeated pressure cycles is not clear, but it seems plausible that some amount of micro-crack propagation occurs.

There is no conclusive evidence that the results of this test program can be directly attributed to any of these mechanisms. However, it does not seem unreasonable to suggest that they might. As far as the implications for use of repaired W/WS, vinyl degradation, stress corrosion cracking, and fatigue affect both repaired and unrepaired W/WS. Only repaired W/WS would seem to be susceptible to the grinding/polishing degradation mechanism.

It would be nice to be able to make generalizations about some W/WS being better repair candidates than others, possibly based on age. Unfortunately, there is just too little data to support such generalizations. There are enough inconsistencies in the data, i.e., new W/WS older than some of the repaired ones, some very old W/WS performing just as well as new W/WS, etc. that one cannot readily see trends in the data. To try to treat the test results in a statistical manner, looking for correlations, just does not make any sense with such small sample populations. The best that one can say is that repaired W/WS are not equivalent to new W/WS.

5.2 Recommendations

In light of the poor performance of the B-52 W/WS in the bird impacts, it is difficult to recommend the wholesale use of repaired glass cockpit W/WS. In the case of the B-52 W/WS, the original design is not up to current W/WS design standards and so even new W/WS do not perform as well as desired. Substituting an old repaired W/WS for a new one merely exacerbates the limitations of the design. Other glass cockpit W/WS, with a more robust design, may be candidates for repairs.

In the context of using repaired W/WS on other glass cockpit W/WS, a number of recommendations can be made as a result of the work performed on this program.

If, in the opinion of the Air Force, the performance of repaired W/WS is deemed "good enough:"

- 1) The repairs done by NORDAM, Perkins, PPG and the Glass Doctor are similar in performance, and restore a W/WS to a condition that exceeds the removal for cause criteria.

- 2) Based on the results of this study, the repair processes that were used and found not to degrade the performance of the W/WS:
 - a) Relaminating using autoclave processes involving application of heat and pressure
 - b) Grinding and polishing of the external surfaces of the glass
 - c) Seal/bumper maintenance
 - d) Minor clean-up of electrical terminals
 - e) Delamination repair involving injection of adhesives or filling with transparent polymerizable resins
 - f) Sensor replacement by potting with transparent resins.
- 3) Repair processes that probably would not be detrimental, but that were not tested:
 - a) Busbar repair using injection of conductive adhesives. (This is virtually identical to delamination by adhesive injection.)
- 4) Repair processes that were not tested and therefore cannot be endorsed:
 - a) Complete front ply replacement.

It is important to emphasize that all of the recommendations offered above are contingent on the Air Force deciding that the performance of the repaired W/WS is adequate. The cost-to-benefit of using repaired W/WS must certainly feature prominently in the decision to use repaired W/WS. It may also be necessary to do selected testing on other glass cockpit W/WS to be certain that they are suitable repair candidates.

5.3 Procurement of Services

The recommended W/WS repair services can be procured through a standard W/WS repair contract with the approved vendors. No out of the ordinary requirements need be specified, because the subject W/WS are virtually identical to the commercial W/WS the vendors routinely repair. The vendors generally do not charge a fee to evaluate the repairability of a W/WS, as long as they have a certain minimum volume of W/WS that they actually can repair.

6.0 REFERENCES

- 1) Forler, C. Richard, *et al*, U.S. Patent # 4,780,162, "Methods for Repairing Laminates", October 25, 1988.
- 2) T.O. 1C-135(K)A-2-2, "Ground Handling, Servicing, and Airframe", Section VIII - Fuselage Windows, Paragraph 8-90.
- 3) T.O. 1B-52B-2-2, "Ground Handling, Servicing, and Airframe Maintenance", Section XI - Fuselage Windows, Paragraph 11-8B.
- 4) 35-18786, Dimension and Arrangement Requirements, Windshield Assembly No. 1.
- 5) 35-18783, Dimension and Arrangement Requirements, Windshield Assembly No. 2 L. and R.H.
- 6) 10-1657, Window Assembly Electrically Heated.
- 7) 10-30347, Windshield Assembly Pilot and Copilots.
- 8) D10-1657, B-52 Specification for Window Assembly Electrically Heated.
- 9) D10-1675, Specification for Sensing Element Windshield Temperature.
- 10) Olson, Richard J., "Development of Repair Processes and Sources for C/KC-135 Aircraft Windows/Windshields", Technical Report for 09/91-01/94 to Oklahoma City Air Logistics Center, Contract FO9603-90-SD-2217-SD02, September 1994.
- 11) Olson, Richard J., "Development of Repair Processes and Sources for B-52 Aircraft Windows/Windshields", Technical Report for 09/91-12/95 to Oklahoma City Air Logistics Center, Contract FO9603-90-SD-2217-SD02, February 1996.
- 12) McLellan G.W. and Shand, E.B., *Glass Engineering Handbook*, McGraw-Hill, New York, 1984, pp. 6-4.
- 13) Phillips, C.J., *Glass, Its Industrial Applications*, Reinhold Publishing Corporation, New York, 1960, pp. 82-85.
- 14) Greene, C.H., *Modern Glass Practice*, Cahners Books, Boston, 1975, pp.358-359.
- 15) Weidehorn, S.M., and Bolz, "Stress Corrosion and Static Fatigue of Glass", *Journal of the American Ceramic Society*, Vol 53, 1970, pp. 543-548.

- 16) Freiman, S.W., "Effects of Chemical Environment on Slow Crack Growth in Glasses and Ceramics", *Journal of Geophysical Research*, Vol 89, 1984, pp.4072-4076.
- 17) Stanworth, J.E., *Physical Properties of Glass*, Oxford Press, London, 1950, pp. 100-101.
- 18) McLellan G.W. and Shand, E.B., *Glass Engineering Handbook*, McGraw-Hill, New York, 1984, pp. 6-4 to 6-6.

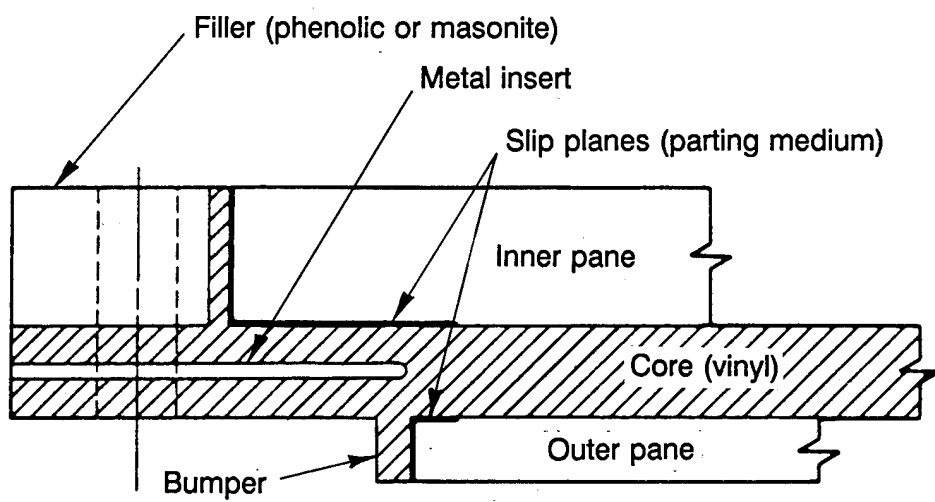

Figure 2.1 C/KC-135 and B-52 W/WS General Construction

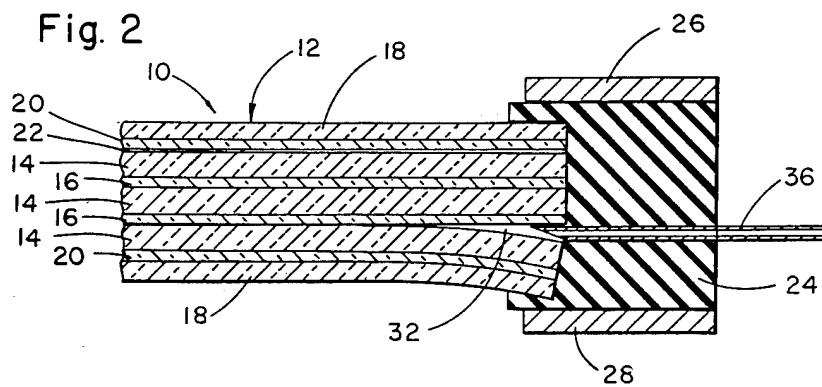
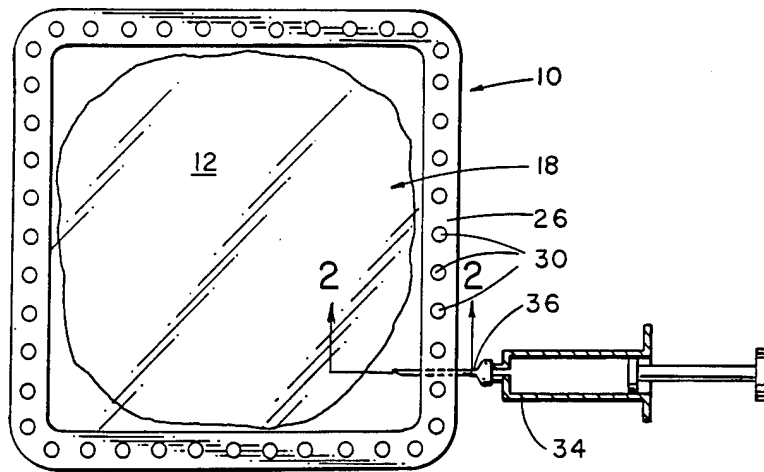

Figure 3.1 The Glass Doctor Patented Technique for Repair of Delaminations in Glass W/WS, U.S. Patent # 4,780,162

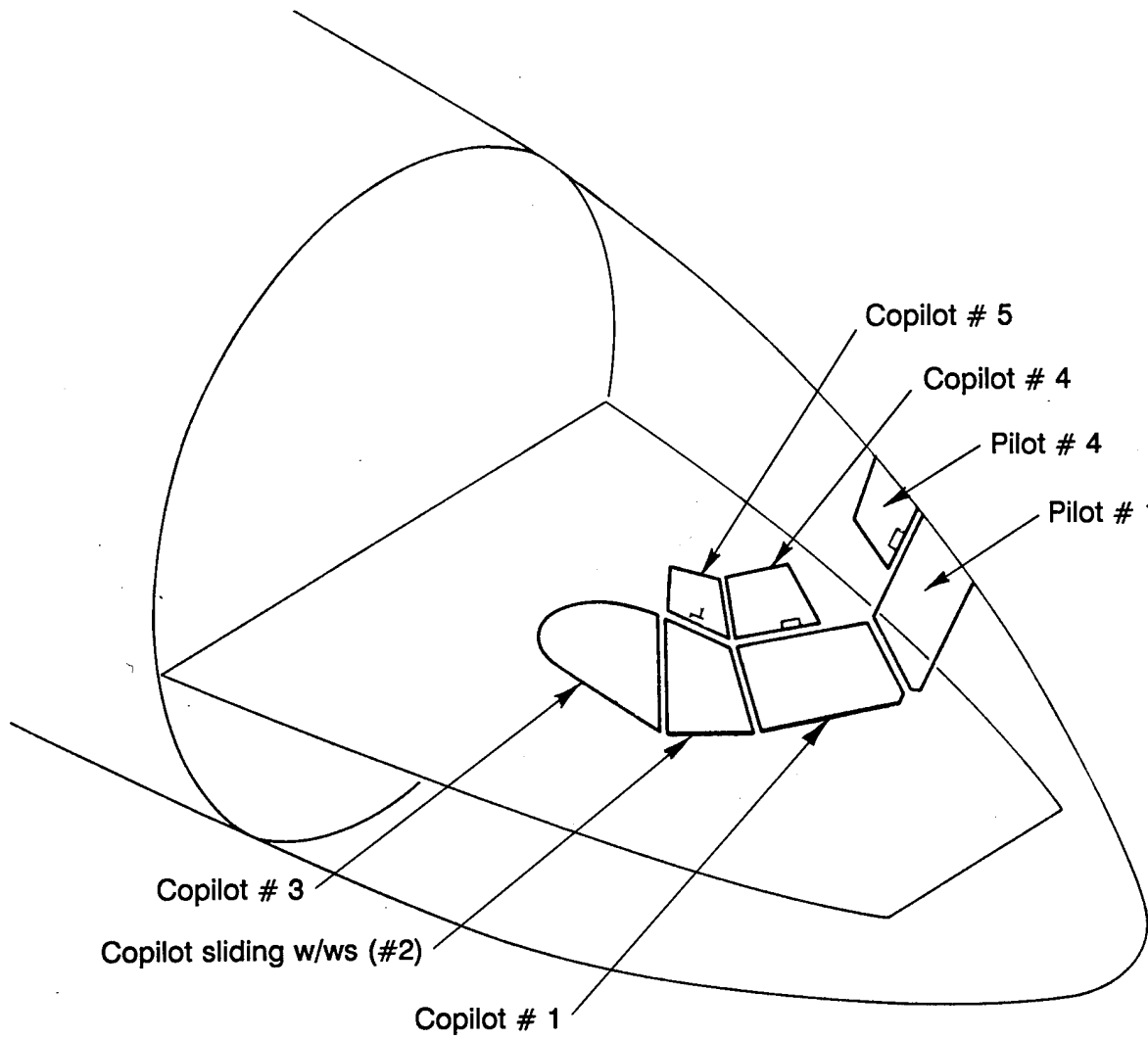

Figure 3.2 C/KC-135 W/WS Identification

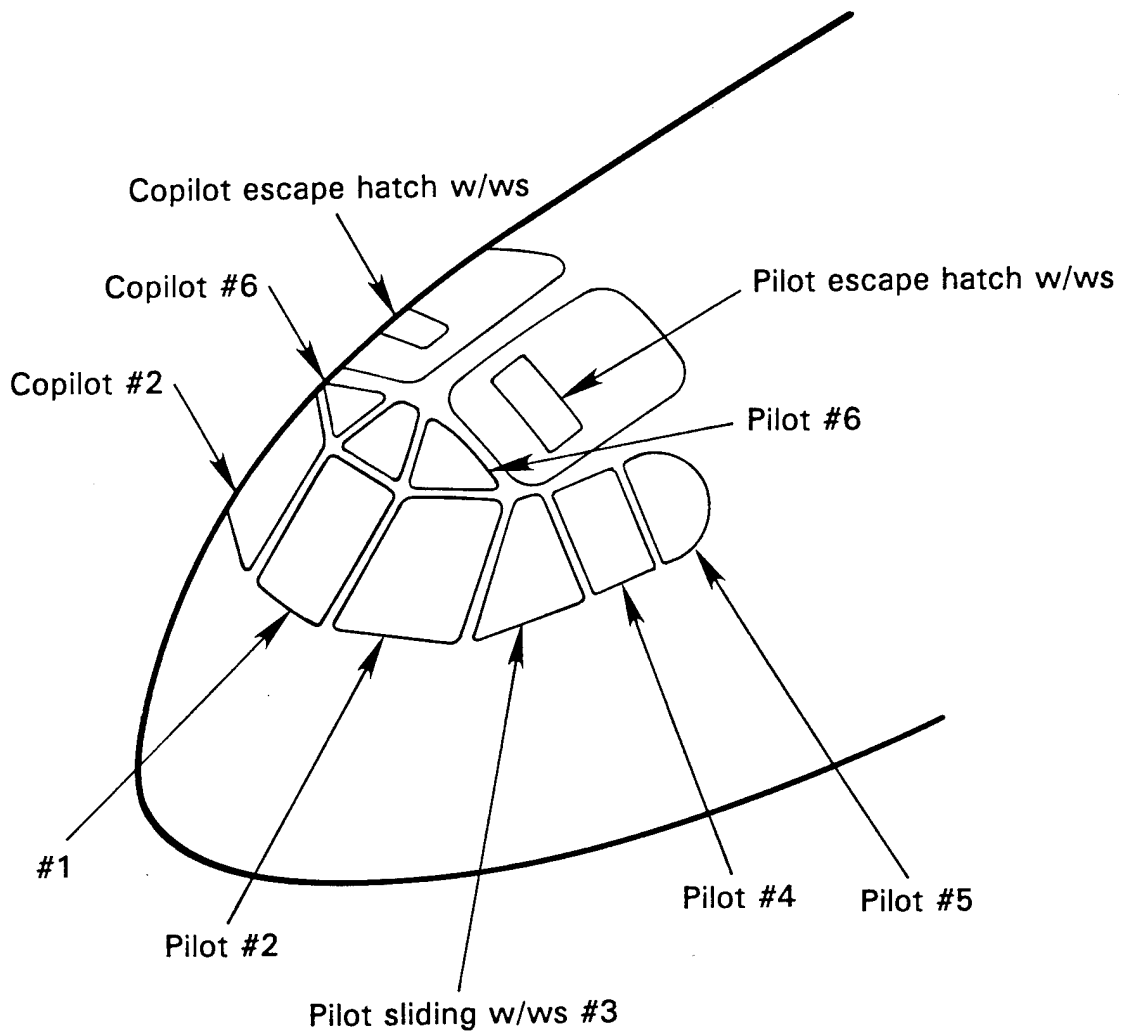
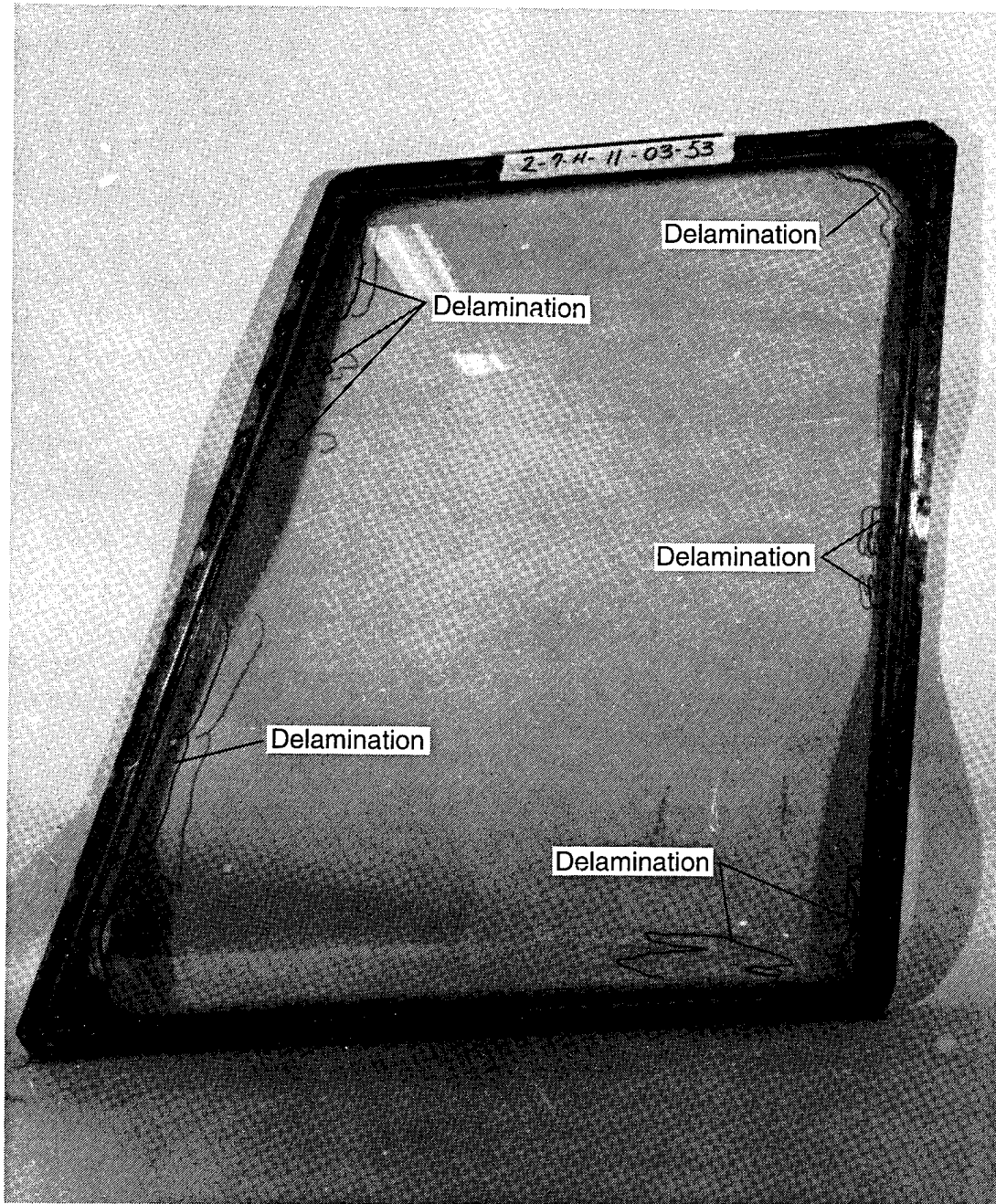

Figure 3.3 B-52 W/WS Identification



**Figure 4.1 Worst Delamination Observed in All Pressure/Thermal Cycle Tests
(B-52 #1 W/WS, S/N 7-H-11-03-53)**

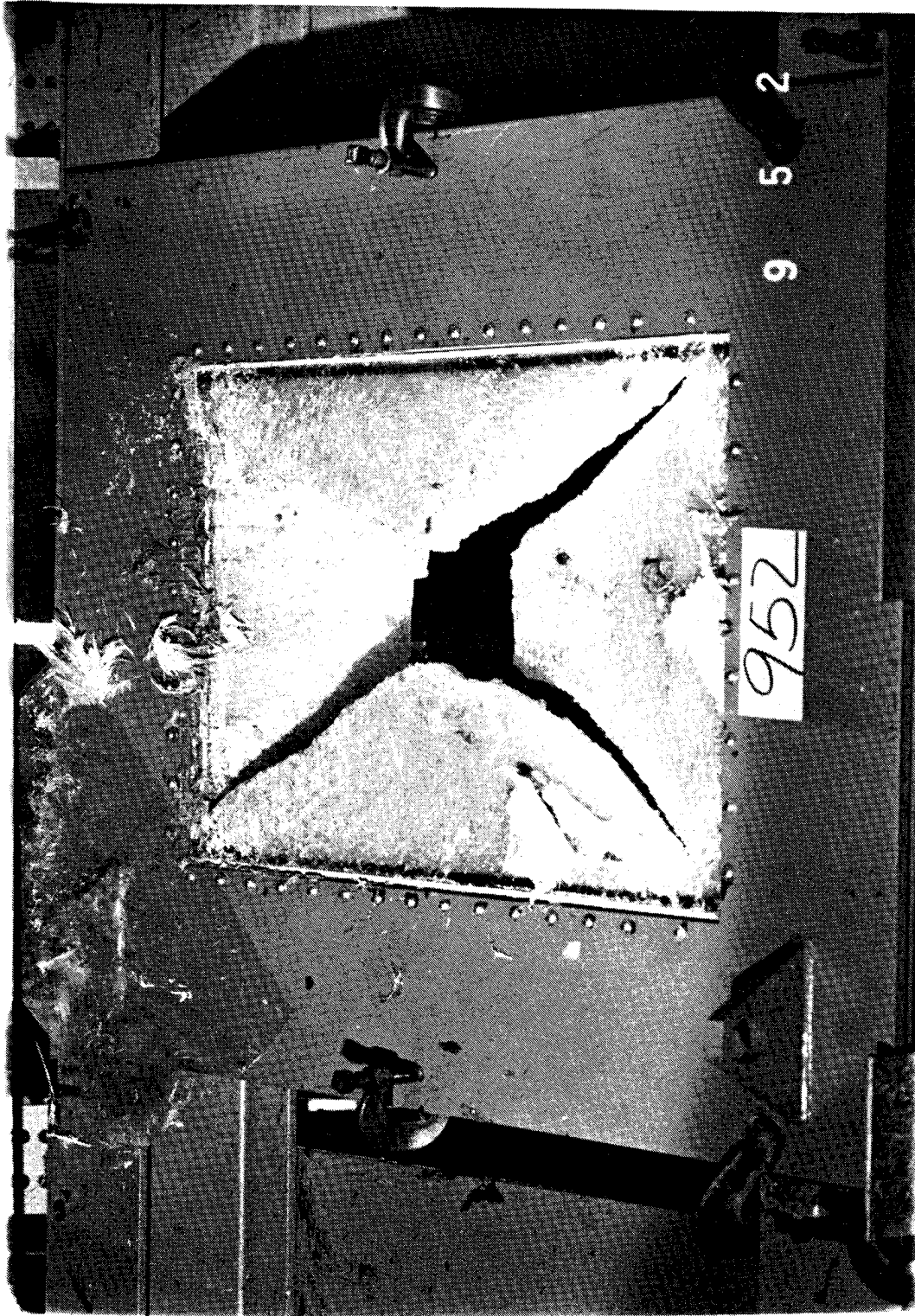
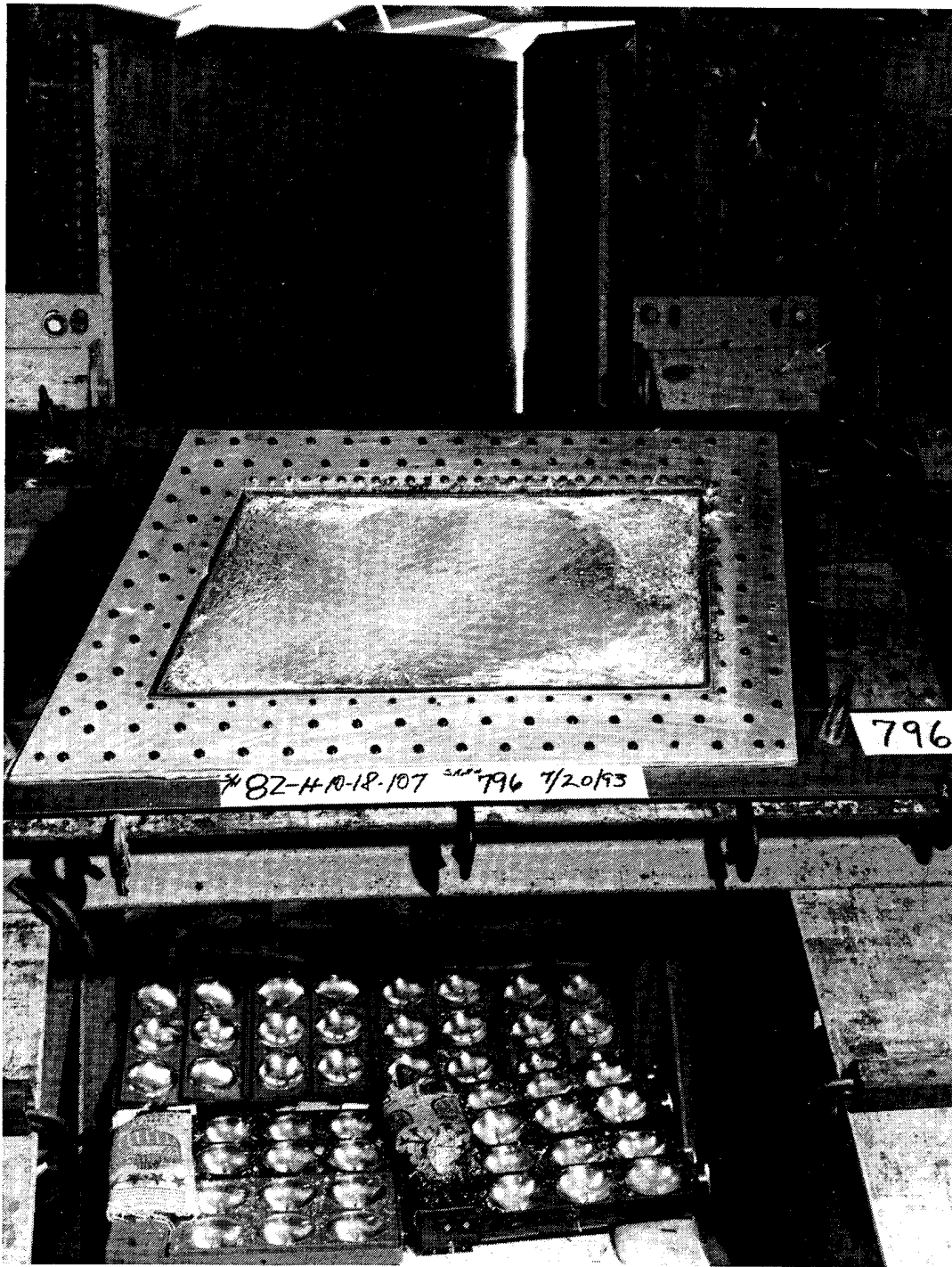
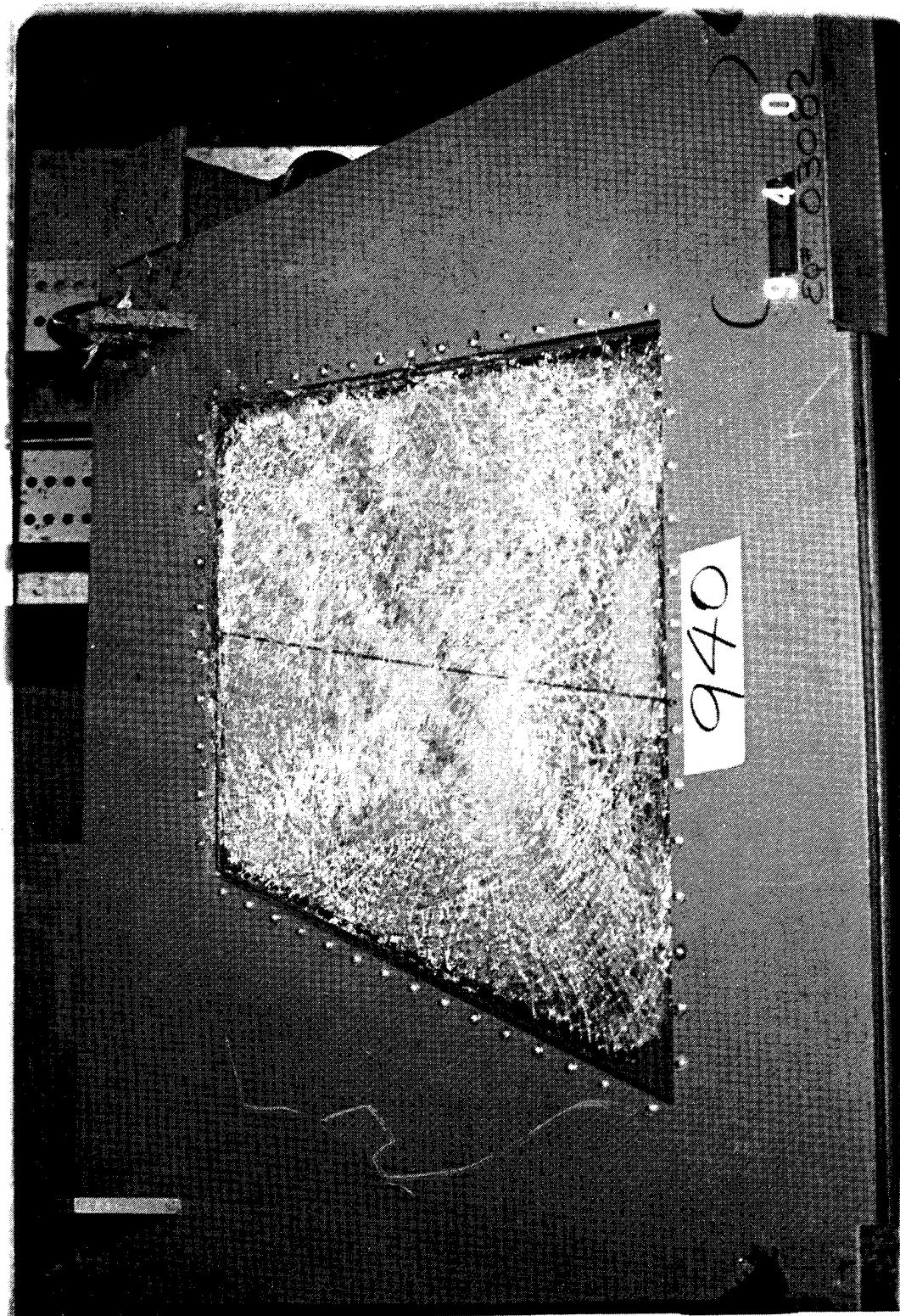

Figure 4.2 Catastrophic W/W Failure From a 4-Pound Bird Impact at 250 Knots
(B-52 #1 W/WS, S/N 86-H-04-28-693)



**Figure 4.3 Both Glass Plies Failure From a 4-Pound Bird Impact at 250 Knots
(C/KC-135 W/WS, S/N 83-H-11-21-325)**



**Figure 4.4 Broken Outboard Glass Ply Failure From a 4-Pound Bird Impact at 300 Knots
(B-52 #2 W/WS, S/N 5-H-3-21-17)**

Table 3.1 C/KC-135 W/WS Part Numbers

Designation	NSN	Part Number
#1 Pilot	1560-01-048-1885 FL	5-89354-501
#1 Copilot	1560-01-048-1786 FL	5-89354-502
#2 Pilot	1560-01-009-3320 FL	5-89355-501
#2 Copilot	1560-01-008-7396 FL	5-89355-502
#3 Pilot	1560-00-575-6302 FL	5-89356-501
#3 Copilot	1560-00-575-6297 FL	5-89356-502
#4 Pilot	1560-00-575-6299 FL	5-71764-501
#4 Copilot	1560-00-575-6298 FL	5-71764-502
#5 Pilot	1560-00-575-6300 FL	5-89358-501
#5 Copilot	1560-00-575-6301 FL	5-89358-502

Table 3.2 B-52 W/WS Part Numbers

Designation	NSN	Part Number
#1 Center	1560-00-738-2714 FG	10-30347-7
#2 Pilot	1560-00-512-0731 FG	10-30347-1
#2 Copilot	1560-00-512-0732 FG	10-30347-2
#3 Pilot	1560-00-533-1797 FG	10-30347-3
#3 Copilot	1560-00-612-2865 FG	10-30347-4
#4 Pilot	1560-00-512-0735 FG	10-30347-5
#4 Copilot	1560-00-055-6758 FG	10-30347-6
#5 Pilot	1560-00-626-2995 FG	10-1389-37
#5 Copilot		
Escape Hatch Pilot	1560-00-630-4218 FG	10-1657-19
Escape Hatch Copilot	1560-00-652-2833 FG	10-1657-20

Table 3.3 C/KC-135 #1 W/WS Repairs

S/N	Repair Vendor	Vendor Damage Comments	Vendor Repair Comments
1-H-10-5-480	Perkins	delaminated, scratched	
82-H-10-18-105		delaminated, scratched	
82-H-10-18-107		delaminated	
83-H-8-15-756		delaminated	
83-H-9-19-282		delaminated	
83-H-9-19-294		delaminated	not repairable
83-H-11-7-432(5?)		delaminated	
84-H-3-19-220		delaminated, scratched	
82-H-9-6-235	NORDAM	scratches	polish, replace bumper and pressure seal
82-H-9-6-537		scratches	polish, replace bumper and pressure seal
82-H-12-6-431		scratches and chips	polish, replace bumper and pressure seal
83-H-9-19-459		scratches and chips	polish, replace bumper and pressure seal
83-H-11-21-325		scratches and chips	polish, replace bumper and pressure seal
86-H-12-01-146		scratches and chips	polish, replace bumper and pressure seal
88-H-02-08-436		scratches	polish, replace bumper and pressure seal
89-286-HO-697		scratches	polish, replace bumper and pressure seal

Table 3.4 C/KC-135 #4 W/WS Repairs

S/N	Repair Vendor	Vendor Damage Comments	Repair Comments
4-H-10-9-69	Perkins	contaminated	not repairable
6-H-12-02-36		bad resistance	not repairable
8-H-2-06-585		delamination, scratches	
82-H-12-6-392		contaminated	not repairable
90-173-HO-721		bad terminal block	
3-H-4-26-45	NORDAM	delamination, scratches, and chips	polish, autoclave, replace bumper and pressure seals
4-H-9-28-87		scratches	polish, replace bumper and pressure seals
4-H-10-15-108		delamination, scratches, bad resistance	not repairable
B75-1149		scratches	polish, replace bumper and pressure seals
5-H-5-23-84		delamination, scratches, bad resistance	not repairable
5-H-12-16-47		delamination, scratches	polish, autoclave, replace bumper and pressure seals
7-H-2-4-35		scratches, bad resistance	not repairable
84-H-10-15-1225		delamination, scratches	polish, autoclave, replace bumper and pressure seals
85-H-07-01-276		scratches	polish, replace bumper and pressure seals
85-H-07-01-366		scratches	polish, replace bumper and pressure seals
87-H-04-20-130		scratches	polish, replace bumper and pressure seals

Table 3.5 B-52 #1 W/WS Repairs

S/N	Repair Vendor	Vendor Damage Comments	Vendor Repair Comments
7-H-1-28-92	The Glass Doctor	-	delamination, polish, seals
83-H-3-21-110		-	delamination, polish, seals
86-H-03-03-298		-	delamination, polish, seals
86-H-04-28-693		-	delamination, replacement sensor, polish, seals
87-H-11-02-614		-	delamination, polish, seals
89-116-HO-366		-	delamination, polish, seals
89-216-HO-298		-	delamination, polish, seals
83-H-3-21-109		PPG	bad bumper/seal, surface scratches, clean
87-H-11-02-396	bad seal/bumper, delamination, clean		repair bumper, clean and inspect
89-H-137-HO-152	bad seal/bumper, clean		repair bumper, clean and inspect
92-288-HO-631	bad seal/bumper, surface scratches (grind & polish required), clean		distortion O.K., repair bumper, clean and inspect

Table 3.6 B-52 #2 W/WS Repairs

S/N	Repair Vendor	Vendor Damage Comments	Vendor Repair Comments
5-H-3-20-17	The Glass Doctor	-	delamination, polish, seals
7-H-11-03-53		-	delamination, polish, seals
8-H-11-20-277		-	delamination, polish, seals
8-H-11-20-436		-	delamination, polish, seals
85-H-07-15-044		-	delamination, replacement sensor, polish, seals
86-H-07-14-260		-	delamination, polish, seals
91-277-HO-574		-	delamination, polish, seals
1-H-11-2-571	PPG	delamination, bad bumper/seal, surface scratches,	polish, polishing distortion, repair bumper clean and inspect
5-H-3-04-09		bad seal/bumper, surface scratches, clean	polish, distortion OK, repair bumper, clean and inspect
86-H-05-12-588		bad bumper/seal, clean	repair bumper, clean and inspect
88-H-06-27-021		surface scratches, rubs, clean	polish, polishing distortion, repair bumper, clean and inspect

Table 3.7 B-52 Escape Hatch W/WS Repairs

S/N	Repair Vendor	Vendor Damage Comments	Vendor Repair Comments
84-H-11-19-090	The Glass Doctor	-	delamination, polish, seals
85-H-02-18-621		-	delamination, polish, seals
87-H-05-04-554		-	delamination, polish, seals
88-H-09-19-253	PPG	bad seal, clean	polish, polishing distortion, clean retainer
92-100-HO-683		bad seal, surface scratches, clean	polish, polishing distortion, clean retainer

Table 4.1 W/WS General Inspection Requirements

Step	Action
1	Locate and record the customer part number
2	Locate and record the W/WS serial number
3	Perform general visual inspection looking for scratches and vinyl defects
4	Conduct gasket/seal evaluation
5	Make thickness measurements at prescribed locations
6	Check physical tolerances using OEM check fixtures
7	Measure bus-to-bus resistance
8	Measure sensing element resistance
9	Perform electrical insulation integrity test
10	Perform heater operation test
11	Perform heating film scratch test
12	Make luminous transmittance and haze measurement
13	Make optical deviation measurement
14	Take optical distortion photograph

Table 4.2 Proof Pressure Test Conditions

Aircraft	Maximum Pressure, psi	Pressurization Rate, psi/minute	Hold Time, min
C/KC-135	12.6	0.84	15
B-52	18.6	1.0	15

Table 4.3 Cyclic Pressure Integrity Testing Schedule for C/KC-135 W/WS

Step	Outboard Air Temp	Inboard Air Temp	Applied Pressure	Applied Voltage	Heat Input	Maintain Conditions Until	Remarks
1	-65 F	72 F	-	-	-	temps stabilized	-
2	-65 F	72 F	-	*	-	temps stabilized	apply power to maintain W/WS temperature
3	-65 F	72 F	9.42 psi	-	-	260 cycles	0.84 psi/min pressure and depressure rate
4	70 F	72 F	-	-	-	temps stabilized	return to ambient conditions
5	Inspect for delamination						
6-10	Repeat Steps 1-5						

*

W/WS	W/WS Letter Code	Voltage, volts
#1	H1	218
	H2	210
	H3	198
#4	-	115

Table 4.4 Cyclic Pressure Integrity Testing Schedule for B-52 #1 AND #2 W/WS

Step	Outboard Air Temp	Inboard Air Temp	Applied Pressure	Applied Voltage	Heat Input	Maintain Conditions Until	Remarks
1	-65 F	70 F	-	-	-	temps stabilized	-
2	-65 F	70 F	-	*	-	temps stabilized	apply power
3	-65 F	70 F	-	*	*	deflections and temps stabilized	adjust air velocity so that heat input is dissipated without voltage cycling
4	-65 F	70 F	15 psi	-	-	250 cycles	1 psi/min pressure and depressure rate
5	-65 F	70 F	-	-	-	temps stabilized	remove power
6	70 F	70 F	-	-	-	temps stabilized	return to ambient conditions
7	Inspect for delamination						
8-14	Repeat Steps 1-7						

*

W/WS	W/WS Letter Code	Voltage, volts	Power, watts
#1	H1	330	2380
	H2	314	
	H3	298	
	H4	421	

W/WS	W/WS Letter Code	Voltage, volts	Power, watts
#2	H1	441	2600
	H2	421	
	H3	398	

Table 4.5 Cyclic Pressure Integrity Testing Schedule for B-52 Escape Hatch W/Ws

Step	Outboard Air Temp	Inboard Air Temp	Applied Pressure	Applied Voltage	Heat Input	Maintain Conditions Until	Remarks
1	-65 F	70 F	-	-	-	temps stabilized	-
2	-65 F	70 F	-	161 V	-	temps stabilized	apply power
3	-65 F	70 F	10 psi	161 V	-	deflections stabilized	apply pressure
4	-65 F	70 F	10 psi	161 V	426 W	until deflections and temps stabilized	adjust air velocity so that heat input is dissipated without voltage cycling
5	-65 F	70 F	-	-	-	deflections stabilized	remove pressure, reduce air velocity to zero
6	-65 F	70 F	-	-	-	temps stabilized	remove power
7	70 F	70 F	-	-	-	temps stabilized	return to ambient conditions
8	Inspect for delamination						
9-48	Repeat Steps 1-8 five times, increasing the pressure applied at Steps 3 and 4 in 1 psi increments to a maximum of 15 psi						
49	-65 F	70 F	-	-	-	temps stabilized	-
50	-65 F	70 F	-	161 V	-	temps stabilized	apply power
51	-65 F	70 F	-	161 V	426 W	temps stabilized	see Step 4
52	-65 F	70 F	13 psi	161 V	426 W	30 minutes	apply pressure
53	-65 F	70 F	18.6 psi	161 V	426 W	30 minutes	add pressure increment
54	70 F	70 F	-	-	-	temps stabilized	return to ambient conditions
55	Inspect for delamination						

Table 4.6 C/KC-135 W/WS General Inspection Summary

Category	#1 W/WS				#4 W/WS			
	New	Repaired		Not Repaired	New	Repaired		Not Repaired
		Perkins	NORDAM			Perkins	NORDAM	
Vendor	-			-	-			-
Number Tested	8	7	8	1	9	2	8	6
Number with delamination, scratches, or chips	0	6	7	1	0	1	8	6
Number with seal deficiencies	0	7	7	1	0	2	7	6
Number with vinyl cracks	0	0	0	1	0	0	2	4
Number with bad dimensional check	0	0	0	0	0	0		0
Number with bad bus resistance	0	0	0	0	0	1	2	3
Number with bad sensor resistance	0	0	0	0	-	-	-	-
Number with bad insulation	0	3	6	1	0	0	0	0
Number with poor heater performance	0	0	0	1	0	0	1	0
Number with optical deficiencies	0	0	0	0	0	0	0	0

Table 4.7 B-52 W/W/S General Inspection Summary

Category	#1 W/W/S				#2 W/W/S				Escape Hatch		
	New	Repaired		Not Repaired	New	Repaired		Not Repaired	New	Repaired	
		GDr	PPG			GDr	PPG			GDr	PPG
Vendor	-	7	4	-	-	7	4	-	-	3	2
Number Tested	2	4	4	3	2	6	4	3	2	3	2
Number with delamination, scratches, or chips	0	4	4	3	0	6	4	3	0	3	1
Number with seal deficiencies	0	0	0	3	0	0	0	3	-	-	-
Number with vinyl cracks	0	0	0	0	0	0	0	0	0	0	0
Number with bad dimensional check	0	0	0	0	0	0	0	0	0	0	0
Number with bad bus resistance	0	1	0	2	0	0	0	0	0	0	0
Number with bad sensor resistance	0	0	0	0	0	0	0	0	-	-	-
Number with bad insulation	0	1	0	1	0	0	0	0	-	-	-
Number with poor heater performance	0	1	0	2	0	0	0	2	0	0	0
Number with optical deficiencies	0	1	1	4	0	0	0	0	0	0	0

Table 4.8 C/KC-135 W/WS Pressure Integrity Test Summary

Category	#1 W/WS				#4 W/WS			
	New	Repaired		Not Repaired	New	Repaired		Not Repaired
		Perkins	NORDAM			Perkins	NORDAM	
Vendor	-			-	-			-
Number Tested	4	3	4	1	4	1	6	1
Number failing initial proof pressure test	0	0	0	0	0	0	0	0
Number failing during pressure cycling	0	0	0	0	0	0	0	0
Number failing final proof pressure test	0	0	0	0	0	0	0	0
Number delaminated	0	0	2	0	0	0	2	0

Table 4.9 B-52 W/WS Pressure Integrity Test Summary

Category	#1 W/WS			#4 W/WS			Escape Hatch		
	New	Repaired		New	Repaired		New	Repaired	
		GDr	PPG		GDr	PPG		GDr	PPG
Vendor	-			-			-		
Number Tested	1	2	2	1	2	2	1	2	2
Number failing initial proof pressure test	0	0	0	0	0	0	0	0	0
Number failing during pressure cycling	0	0	0	0	0	0	0	0	0
Number failing final proof pressure test	0	0	0	0	0	0	0	0	0
Number delaminated	1	1	1	1	2	2	0	1	1

Table 4.10 C/KC-135 W/WS Bird Impact Test Summary
(250 Knots, 4-Pound Bird)

Category	#1 W/WS				#4 W/WS			
	New	Repaired		New	Repaired		Not Repaired	
		Perkins	NORDAM		Perkins	NORDAM		
Vendor	-			-				-
Number Tested	4	4	4	5	1	2	5	
Number undamaged	3	0	2	4	1	1	2	
Number with one glass ply broken	1	2	1	1	0	1	1	
Number both glass plies broken	0	2	1	0	0	0	2	
Number with no inner ply glass spall	4	2	3	5	1	2	3	
Number with minor inner ply glass spall	0	2	1	0	0	0	1	
Number with major inner ply glass spall	0	0	0	0	0	0	1	
Number with no bird penetration	4	4	4	5	1	2	4	
Number with minor bird penetration	0	0	0	0	0	0	0	
Number with major bird penetration	0	0	0	0	0	0	1	

Table 4.11 B-52 #1 W/WS Bird Impact Test Summary
(4-Pound Bird)

Category	New	Repaired				Not Repaired		
		200	250	300	200	250	300	
Velocity, knots	250							
Vendor	-	GDr	GDr	PPG	GDr	-	-	-
Number Tested	1	1	2	2	1	1	1	1
Number undamaged	1	0	1	2	0	1	1	0
Number with one glass ply broken	0	1	0	0	0	0	0	0
Number both glass plies broken	0	0	1	0	1	0	0	1
Number with no inner ply glass spall	1	1	1	2	0	1	1	0
Number with minor inner ply glass spall	0	0	0	0	0	0	0	0
Number with major inner ply glass spall	0	0	1	0	1	0	0	1
Number with no bird penetration	1	1	1	2	0	1	1	0
Number with minor bird penetration	0	0	0	0	0	0	0	0
Number with major bird penetration	0	0	1	0	1	0	0	1

Table 4.12 B-52 #2 W/WS Bird Impact Test Summary
(4-Pound Bird)

Category	New	Repaired			Not Repaired
		200	300	400	
Velocity, knots	300				300
Vendor	-	GDr	PPG	GDr	-
Number Tested	1	1	2	1	1
Number undamaged	1	1	0	0	1
Number with one glass ply broken	0	0	0	0	0
Number both glass plies broken	0	0	2	1	0
Number with no inner ply glass spall	1	1	0	0	1
Number with minor inner ply glass spall	0	0	1	0	0
Number with major inner ply glass spall	0	0	1	1	0
Number with no bird penetration	1	1	1	0	1
Number with minor bird penetration	0	0	0	0	0
Number with major bird penetration	0	0	1	1	0