

**REPAIRED GLASS COCKPIT
W/WS SYSTEM SAFETY REPORT**

REPORT

RICHARD J. OLSON

**BATTELLE
505 KING AVENUE
COLUMBUS, OH 43201**

FEBRUARY 1996

**SYSTEMS SAFETY HAZARDS ANALYSIS REPORT FOR 09/91 - 2/96
CONTRACT NUMBER FO9603-90-D-2217-SD02**

**DISTRIBUTION AUTHORIZATION: APPROVED FOR PUBLIC RELEASE;
DISTRIBUTION IS UNLIMITED**

19960412 125

**PREPARED FOR
OKLAHOMA CITY AIR LOGISTICS CENTER
TINKER AFB, OK 73145**

This report is a work prepared for the United States Government by Battelle. In no event shall either the United States Government or Battelle have any responsibility or liability for any consequences of any use, misuse, inability to use, or reliance upon the information contained herein, nor does either warrant or otherwise represent in any way the accuracy, adequacy, efficacy, or applicability of the contents hereof.

REPORT DOCUMENTATION PAGE			Form Approved OMB No. 0704-0188	
Public reporting burden for this collection of information is estimated to average 1 hour per response, including the time for reviewing instructions, searching existing data sources, gathering and maintaining the data needed, and completing and reviewing the collection of information. Send comments regarding this burden estimate or any other aspect of this collection of information, including suggestions for reducing this burden, to Washington Headquarters Services, Directorate for Information Operations and Reports, 1215 Jefferson Davis Highway, Suite 1204, Arlington, VA. 22202-4302, and to the Office of Management and Budget, Paperwork Reduction Project (0704-0188), Washington, DC 20503.				
1. AGENCY USE ONLY (Leave blank)	2. REPORT DATE February 1996	3. REPORT TYPE AND DATES COVERED Systems Safety Hazards Analysis Report, 9/01/91 - 2/29/96		
4. TITLE AND SUBTITLE Repaired Glass Cockpit W/WS System Safety Report			5. FUNDING NUMBERS	
6. AUTHOR(S) Richard J. Olson			8. PERFORMING ORGANIZATION REPORT NUMBER Contract FO9603-90-D-2217-SD02	
7. PERFORMING ORGANIZATION NAME(S) AND ADDRESS(ES) Battelle 505 King Avenue Columbus, Ohio 43201-2693			10. SPONSORING/MONITORING AGENCY REPORT NUMBER VEP87CR52R1	
9. SPONSORING/MONITORING AGENCY NAME(S) AND ADDRESS(ES) Oklahoma City Air Logistics Center OC-ALC/TIET-R 3001 Staff Drive, Suite 2AG70A Tinker AFB, OK 73145-3040 Technology Transition Office AFMT TTO/TTP 2690 C, Suite 5 Wright-Patterson AFB, OH 45433-7412			11. SUPPLEMENTARY NOTES	
12a. DISTRIBUTION/AVAILABILITY STATEMENT Approved for public release; distribution is unlimited			12b. DISTRIBUTION CODE	
13. ABSTRACT (Maximum 200 Words) The use of repaired glass cockpit W/WS is being considered by the Air Force. There are risks associated with the use of repaired W/WS that could result in the loss of crew members and/or planes. This report documents the risks and makes recommendations for ways to mitigate the risks.				
14. SUBJECT TERMS Risk, Safety, Aircraft Transparencies, Windows/Windshields, Repair, C/KC-135, B-52, Bird Impact, Delamination			15. NUMBER OF PAGES	
17. SECURITY CLASSIFICATION OF REPORT Unclassified			16. PRICE CODE	
18. SECURITY CLASSIFICATION OF THIS PAGE Unclassified			19. SECURITY CLASSIFICATION OF ABSTRACT Unclassified	
20. LIMITATION OF ABSTRACT Unlimited				

This page intentionally left blank.

TABLE OF CONTENTS

	<u>Page</u>
SUMMARY	viii
PREFACE	ix
1.0 INTRODUCTION	1
1.1 Background	1
1.2 Objective	1
1.3 Approach	1
1.4 Report Contents	1
2.0 SYSTEM DESCRIPTION	3
2.1 Glass W/WS Construction	3
2.2 Glass W/WS Damage	5
2.3 Glass W/WS Repairs	6
3.0 REPAIRED GLASS COCKPIT W/WS PERFORMANCE DATA	9
3.1 Program Prototype Repair W/WS	9
3.2 Prototype W/WS Repairs	9
3.3 Performance Data	10
3.3.1 Test Procedures	10
3.3.2 Test Results	11
4.0 HAZARD ANALYSIS RESULTS	13
4.1 Poor Optical Performance	13
4.1.1 Failure Mode	13
4.1.2 System Events Phase	13
4.1.3 Effect on System	13
4.1.4 Risk Assessment	14
4.1.5 Recommended Action	14
4.2 Failure to Adequately De-ice/Defog	14
4.2.1 Failure Mode	14
4.2.2 System Events Phase	14

TABLE OF CONTENTS (Continued)

	<u>Page</u>
4.2.3 Effect on System	15
4.2.4 Risk Assessment	15
4.2.5 Recommended Action	15
4.3 Delamination	15
4.3.1 Failure Mode	15
4.3.2 System Events Phase	15
4.3.3 Effect on System	16
4.3.4 Risk Assessment	16
4.3.5 Recommended Action	16
4.4 Bird Impact Damage	16
4.4.1 Failure Model	16
4.4.2 System Events Phase	16
4.4.3 Effect on System	16
4.4.4 Risk Assessment	17
4.4.5 Recommended Action	17
4.5 Status	17
5.0 REFERENCES	18

LIST OF FIGURES

2.1 C/KC-135 W/WS Identification	19
2.2 B-52 W/WS Identification	20
2.3 C/KC-135 and B-52 W/WS General Construction	21
3.1 Worst Delamination Observed in all Pressure/Thermal Cycle Tests (B-52 #1 W/WS, S/N 2-7-H-11-03-53)	22
3.2 Catastrophic W/WS Failure From a 4-Pound Bird Impact at 250 Knots (B-52 #1 W/WS, S/N 86-H-04-28-693)	23
3.3 Both Glass Plies Failure From a 4-Pound Bird Impact at 250 Knots (C/KC-135 #1 W/WS, S/N 83-H-11-21-325)	24
3.4 Broken Outboard Glass Ply Failure From a 4-Pound Bird Impact at 300 Knots (B-52 #2 W/WS, S/N 5-H-3-20-17)	25

TABLE OF CONTENTS (Continued)

Page

LIST OF TABLES

2.1	C/KC-135 W/WS Part Numbers	26
2.2	B-52 W/WS Part Numbers	26
3.1	C/KC-135 #1 W/WS Repairs	27
3.2	C/KC-135 #4 W/WS Repairs	28
3.3	B-52 #1 W/WS Repairs	29
3.4	B-52 #2 W/WS Repairs	30
3.5	B-52 Escape Hatch W/WS Repairs	30
3.6	W/WS General Inspection Requirements	31
3.7	W/WS Proof Pressure Test Conditions	31
3.8	Cyclic Pressure Integrity Testing Schedule for C/KC-135 W/WS	32
3.9	Cyclic Pressure Integrity Testing Schedule for B-52 #1 and #2 W/WS	33
3.10	Cyclic Pressure Integrity Testing Schedule for B-52 Escape Hatch W/WS	34
3.11	C/KC-135 W/WS General Inspection Summary	35
3.12	B-52 KW/WS General Inspection Summary	36
3.13	C/KC-135 W/WS Pressure Integrity Test Summary	37
3.14	B-52 W/WS Pressure Integrity Test Summary	37
3.15	C/KC-135 W/WS Bird Impact Test Summary (250 Knots, 4-Pound Bird)	38
3.16	B-52 W/WS Bird Impact Test Summary (4-Pound Bird)	39

SUMMARY

The Air Force, in trying to reduce fleet maintenance costs, is considering using repaired windows/windshields (W/WS). Based on reported cost savings and favorable experience that commercial fleets have had with repaired W/WS, the use of repaired W/WS seems very attractive. As a part of the process of evaluating the viability of using repaired W/WS, a safety and hazards analysis was performed for repaired W/WS.

The data for the safety and hazards analysis was developed from structural tests performed on new, repaired, and not repaired C/KC-135 and B-52 W/WS. The test results indicate that repaired W/WS do not perform as well as new W/WS. Many of the repaired W/WS still contain defects that would not pass an OEM quality assurance inspection. None of the W/WS tested, whether new, repaired, or not repaired, exhibited any dramatic differences in pressure integrity. Some delamination occurred in a few of the repaired W/WS during pressure cycling, but it was not severe. Delamination was also observed in the new B-52 W/WS. The most demanding structural test is bird impact. The bird impact test results are quite clear - the new W/WS outperform either repaired or unrepaired W/WS. Some of the repaired and unrepaired W/WS showed no evidence of damage. Others, however, failed catastrophically allowing the bird to enter the cockpit.

Added risks associated with using repaired W/WS instead of new W/WS range from benign, i.e., annoying to the pilot, to loss of the crew and plane. In most cases, the probability of events with drastic consequences is low. However, the consequences of these low probability events is higher when repaired W/WS are used.

PREFACE

The work reported herein was performed by Battelle, Columbus, Ohio, under Air Force Contract FO9603-90-D-2217-SD02, "Development of Repair Processes and Sources for C/KC-135 and B-52 Aircraft Windows/Windshields". The program was directed by the Oklahoma City Air Logistics Center (OC-ALC) at Tinker Air Force Base. Air Force administrative direction was provided by Ms. Cindy Cooper, OC-ALC/LADCB. Air Force technical direction was provided by Mr. Robert Koger, OC-ALC/TIETR.

The work was performed during the period of September 1991 to March 1996. The technical program at Battelle was directed by Mr. Richard Olson of Battelle's Engineering Mechanics Department. The author wishes to acknowledge all of the glass W/WS repair vendors who worked on this study: PPG Industries, Inc., The Glass Doctor, NORDAM Transparency Division, Perkins Aircraft Services, Inc., and Pilkington plc. Special thanks must also be given to the dedicated staff at PPG Industries where the W/WS testing was performed. Lastly, Mrs. Verna Kreachbaum at Battelle must be recognized for her efforts in preparing the manuscript.

1.0 INTRODUCTION

1.1 Background

Many commercial airlines currently use repaired glass cockpit windows/windshields (W/WS) to reduce their operating costs. For commercial fleets, W/WS represent the fifth highest airplane operating expense, behind engines, fuel, tires, and brakes. Because the cost of repairing a cockpit W/WS can be substantially less than the purchase price of a new W/WS, there is an incentive to use repaired W/WS. The repairs are performed by a number of different U.S. Federal Aviation Authority (FAA)-approved vendors.

The U.S. Air Force (USAF) has not joined the commercial fleets in endorsing the use of repaired W/WS. With decreasing Congressional funding for the military, however, measures to reduce fleet operating costs are receiving greater scrutiny. Thus, the use of repaired W/WS is being given serious consideration.

In September 1991, the Air Force contracted with Battelle to investigate the feasibility of using repaired glass cockpit W/WS. During the course of this study, W/WS were repaired at several commercial repair vendors and then tested. This report evaluates and summarizes the safety considerations and risks associated with using repaired W/WS based on the performance of the repaired W/WS.

1.2 Objective

The objective of the work reported herein is to catalog the repairs made to two sets of glass military aircraft cockpit W/WS, to summarize the results of tests conducted on the repaired W/WS, and from the results of the tests, document the safety implications of a decision to use repaired W/WS.

1.3 Approach

Glass cockpit W/WS were removed from C/KC-135 and B-52 aircraft and were sent to commercial repair vendors for refurbishment. The repaired W/WS were inspected for conformance with OEM W/WS specifications, and then they were subjected to pressure/thermal cycle tests and bird impact tests to see how they performed. The test data are used to determine the safety of repaired W/WS.

1.4 Report Contents

The results of this study are presented in the sections that follow. Topics presented include:

- A description of glass cockpit W/WS systems
- A discussion about the selection and repair of W/WS in this program

- A summary of the W/WS test results
- Analysis of the safety and hazards associated with using repaired W/WS.

2.0 SYSTEM DESCRIPTION

Glass cockpit W/WS from two different aircraft were used in the program to evaluate the safety of repaired W/WS. At the beginning of the program, repairs were made on C/KC-135 W/WS. Subsequently, a decision was made to expand the scope of the program to include B-52 W/WS.

The C/KC-135 has 10 cockpit W/WS identified in Figure 2.1, 5 on the pilot side and 5 on the copilot side. The set of five W/WS on the copilot side are a mirror image of the pilot side W/WS. W/WS #1 is the forward W/WS, #2 and #3 are side W/WS, and #4 and #5 are eyebrow W/WS. All of the W/WS except #2 are fixed-position W/WS. W/WS #2 opens to provide ventilation and ground communication by sliding aft on a track. Table 2.1 lists the current part numbers for C/KC-135 W/WS.

The B-52 has 13 cockpit W/WS, a front center one and six on each side of the aircraft. The #3 W/WS on each side of the B-52 can slide on a track. Figure 2.2 shows the location and numbering scheme for the B-52 W/WS. Unlike the C/KC-135, all B-52 W/WS are not glass; the #6 W/WS is made of stretched acrylic plastic. Table 2.2 lists the current W/WS part numbers for the B-52.

2.1 Glass W/WS Construction

Figure 2.3 shows the general construction of the glass C/KC-135 and B-52 W/WS. The W/WS have a three-part glass and vinyl laminate construction. The inner layer is thick, heat-strengthened plate glass designed to withstand cabin pressure forces. A transparent, plasticized, polyvinyl butyral core layer acts as the "fail-safe" load carrying member and prevents shattering in the event of inner ply failure. The outer ply is a relatively thin layer of heat-strengthened glass with no structural significance, but it provides rigidity and a scratch-resistant surface. A phenolic or masonite filler strip, located around the edge of the W/WS, and a metal filler strip embedded in the vinyl provide the means to attach the W/WS to the airframe. Vinyl or vinyl and rubber bumpers protect the edges of the glass plies.

The structural integrity design of C/KC-135 and B-52 cockpit W/WS is based on two requirements: "fail-safe" pressure integrity and bird impact resistance. The "fail-safe" pressure integrity is founded on two redundant systems, an inner glass ply that can sustain the full rated cabin pressure in the absence of all other layers, and a polymeric core ply that can maintain pressure integrity if the inner and outer glass plies are cracked. The bird impact structural integrity of W/WS is either characterized as "bird bagging" or "bird bounce." Bird bagging W/WS, typically two glass layers with a polymeric core ply, stop bird penetration by large ductile deformation of the core ply, i.e., "bagging" the bird. Bird bounce W/WS are typically multi-laminates and cause the bird to "bounce" off the W/WS. The C/KC-135 and B-52 W/WS cockpit W/WS are "bird bagging" W/WS.

The glass used in C/KC-135 and B-52 W/WS is heat strengthened to provide resistance to cracking. The glass is heated to near the softening point and then quenched to produce compressive residual stresses that extend from the outer surface into a depth of about $1/6^{\text{th}}$ of the glass thickness. Below the compressive stress layer lies tensile residual stresses. As long

as surface defects do not penetrate into the tensile layer, the glass will exhibit a high resistance to fracture. Once a crack does fully penetrate the tensile layer, the glass will shatter as the tensile stresses are relieved.

The vinyl core, which acts as the "fail-safe" pressure boundary and means for controlling glass fragments in the event of a glass ply failure, is highly plasticized polyvinyl butyral. The vinyl is relatively brittle at low temperatures (-65° F), and unable to absorb much energy per unit volume. At temperatures approaching 130° F, the vinyl becomes very ductile and can absorb a relatively large amount of energy as it is loaded. W/WS heaters, which not only de-fog and de-ice the glass, ensure that the vinyl remains ductile.

An integral part of the C/KC-135 and B-52 W/WS construction is slip planes or a parting medium at the edges of the glass. A slip plane is located between both the inner glass ply and the vinyl and the outer glass ply and the vinyl as shown in Figure 2.3. The slip planes are thin strips of material at the glass-vinyl interface that keep the glass from bonding to the vinyl. This allows the various plies to move independently at these locations in response to pressure loads and differential thermal expansion. Without the slip planes, the glass at the edges of the W/WS would be prone to fracture because it would exceed its strain limit as it tried to move with the underlying vinyl. The slip planes form a "softer" connection that promotes a more gradual build up of strains in the glass so that it does not exceed its strain capacity. Although the slip planes look similar to delamination, they are not defects but an intentional part of the W/WS design.

The C/KC-135 and B-52 cockpit W/WS contain heating systems for anti-icing and/or anti-fogging. An electrically conductive film of pyrolytic tin oxide between the outer glass ply and the vinyl core ply is used to heat C/KC-135 and B-52 W/WS to reduce ice/frost formation. A similar conductive film between the inner ply and core ply is used on some W/WS for defogging only. The W/WS heating system, so called NESAS[®] coated glass, uses the resistivity of the film to provide the heating. A few of the C/KC-135 W/WS also contain fine wires at the W/WS edges between the outer glass ply and vinyl, so-called edge heaters, to correct a heating power deficiency in the corners. The temperature of some W/WS is controlled with an integral sensor embedded in the laminate. Externally applied thermal switches control the temperature on other W/WS.

Seals on the W/WS keep cabin pressure in and moisture out. In addition, they act as vibration and shock absorbers and help to compensate for differential thermal expansion between the W/WS and the airframe. The C/KC-135 W/WS utilize a silicone rubber molded-in-place pressure seal that is molded to the W/WS mounting surface. A few of the molded-in-place seals have a stainless steel z-channel sandwiched between a silicon rubber cushion and the beaded pressure seal. The B-52 W/WS use either molded-in-place seals or pre-made polysulfide rubber seals that are glued onto the W/WS frame with polysulfide rubber. All of the C/KC-135 and B-52 W/WS, except the B-52 escape hatch W/WS, mount from the inside of the aircraft. Drawing the W/WS tight to the airframe with mounting bolts effects the seal.

Many of the W/WS on the C/KC-135 and B-52 are flat. The W/WS directly in front of the pilot fall into this category. Because they are flat, they are easy to manufacture and repair. In addition, they have very good optics. Several of the C/KC-135 and B-52 W/WS are curved. Some of them have a single axis of curvature, while others have compound curvature. The

curvature tends to result in some degree of optical distortion, and the curvature makes it somewhat more difficult than flat W/WS to repair, in spite of the fact that the curved W/WS are generally smaller than the flat ones.

2.2 Glass W/WS Damage

The most common failure modes of laminated glass transparencies are:

- Delamination: separation of vinyl from the glass
- Cracks and chipping: glass breakage due to high stress
- Arcing: unbalanced electrical potential within the conductive coating
- Heater Failure: loss of continuity in the heater or sensor circuit or low power
- Impaired Vision: due to surface scratches, contaminates, or internal defects
- Contamination: air or water leaks caused by defective seals
- Vinyl cracking.

Delamination is separation of the glass surface of the inner or outer ply from the vinyl core ply to which it is bonded. Delamination generally starts at the slip planes and moves inward, although it may occur anywhere in the W/WS. It mainly occurs between the outer ply and the vinyl ply. Delamination does not dramatically reduce the strength of the W/WS, but may interfere with vision or W/WS heating if the delamination occurs at the interface where the heating film is located.

Cracks and chips may occur in either of the glass plies and may be caused by impacts or by high stresses at the edges of the glass. Single cracks in the outer ply are unlikely because the temper in this layer precludes a single crack. After the momentary appearance of a crack in the outer layer, the entire layer shatters very abruptly. Small cracks very near the edges of the W/WS may not be cause for removal, provided the crack is not directed toward the center of the pane. Cracks that adversely affect the functioning of the heater would not be acceptable. Chips may occur internally or externally. Internal chips are caused by the glass-vinyl bond strength exceeding the strength of the glass. External chips are generally caused by impacts. Chips usually have a clamshell shape, are rough, and white powdered glass is often in evidence. Chips are detrimental to the strength of the pane.

W/WS busbar breakdown and faults in the heater film cause arcing. Basically, the insulation breaks down and the heater electrical current short circuits to the airframe. Arcing is evidenced by burned areas around electrical braid and along the busbar.

The failure of the W/WS heater to de-ice or defog satisfactorily is one of the most serious failure modes. Arcing, chips, cracks, or lack of continuity in the heater film that

render the heater inoperative are cause for W/WS replacement. Uneven heating or hot spots caused by delamination at the glass-vinyl interface with the heating film or chips may also be a cause for removal. As W/WS age, the resistance of the heater generally rises. In order to provide the same power for defogging or de-icing, the voltage applied to the W/WS must be increased. At the maximum possible voltage (which is governed by the design of the W/WS autotransformer and the current carrying capacity of the wiring to the W/WS), if the W/WS heater resistance is above allowable specifications, the heater will be perceived as being ineffective.

Satisfactory optical properties of the W/WS are paramount. Foggy or cloudy areas may appear in places where moisture has penetrated the vinyl and has begun to degrade it. Scratches that may interfere with visibility can occur on both the inner and outer plies. Likewise, delamination may become serious enough to warrant replacement of the W/WS on the basis of reduced visibility. Bubbles may occur in the vinyl core ply in W/WS that have been exposed to elevated temperatures. Bubbles are caused by gas liberated from the vinyl, and grow in size and number with increased temperature or longer exposures. Unnecessary operation of the heaters on the ground is a prime cause of bubbles. Bubbles do not have a large effect on strength of the W/WS, but may become serious enough to impair visibility. Although other failure modes may not be evident, poor optical performance is always a sufficient cause for W/WS replacement.

The bumpers on the edges of the glass form a moisture barrier. Degradation of bumpers in the form of cracking or separation from the edge of the glass ply can allow moisture and air to get into the slip planes. Moisture can degrade the heater film with consequent initiation of heater failure, arcing, delamination, and contamination.

As a result of aging, cracks can occur in the vinyl. Over time, attack by ultraviolet radiation and high temperatures also causes the vinyl to lose ductility. Eventually, cracks may form around the periphery of the W/WS in proximity to the metal insert as the glass and vinyl try to move relative to one another. Vinyl cracks significantly weaken the structure of the W/WS by putting flaws directly in the load path between the transparency and the airframe for bird impact loads. Per Figure 2.3, only the vinyl extends out to the mounting holes, not the glass. Therefore, if the vinyl is cracked near the metal insert, the W/WS could just "punch out" of the frame into the cabin in a bird impact situation. The vinyl layer is also the pressure "fail-safe" layer, so vinyl cracks are quite important.

In addition to cracking, the vinyl layer may discolor or darken if it is subjected to temperatures in excess of 225° F. Foreign substances in the glass-vinyl interface, either from in-service conditions or introduced as a part of a repair process, may also cause discoloration.

2.3 Glass W/WS Repairs

The manufacture of a new W/WS is conceptually quite simple - two layers of glass are bonded together with vinyl under heat and pressure to form an optically acceptable transparency. Likewise repairing a damaged W/WS is also conceptually simple - rebond separated laminates, and remove unacceptable scratches, chips, and cracks. Unfortunately, although the concept of manufacturing a new W/WS or repairing a damaged one is quite

simple, the implementation requires a great deal of "art" and practice to become skilled at making successful repairs.

Economical glass cockpit W/WS repairs are generally limited to the exterior surfaces that are accessible without disassembling the windshields. In exceptional cases, when the cost of a new W/WS is high, W/WS can be disassembled for repair by separating the glass and vinyl layers.

W/WS repairs can be conveniently divided into four categories:

1) Electrical heater system repairs

Electrical heater repair is limited to re-connecting the resistive wiring when the resistance reading is infinite. W/WS with resistance readings outside the acceptable ranges, other than open circuits, are deemed un-serviceable.

An open circuit can possibly be repaired by manually soldering the accessible breaks in the electrical braid. Corrosion can be removed from exposed terminal blocks using a fine grade abrasive. Repair of open or arcing busbars can also be effected by injecting a conductive adhesive material at the glass-vinyl interface where the busbar defect is located.

2) Delamination

Delamination between the glass and vinyl plies of the W/WS greater than 40-percent of the W/WS area, or vinyl tearing is deemed un-serviceable and the W/WS is scrapped. The use of an autoclave to laminate glass sheets, laminates, and transparencies is cited in a number of patents. A 1967 PPG Industries Inc. patent, # 3,311,517^[1], cited an oil autoclave curing cycle of "up to 30 minutes or more at a temperature of about 190 to 325 degrees Fahrenheit, preferably about 225 to 300 Fahrenheit, and simultaneous pressures of between 100 and 250 pounds per square inch, depending on the thickness of the components of the assembly to be laminated and the number of interfaces between the components." The use of autoclaves that use oil to apply pressure to the W/WS has been superseded by autoclaves that apply pressure using air, with the W/WS in vacuum bags. Repair of delamination by injection of adhesives into the W/WS is also possible^[2].

3) Surface defects

Repairable "minor" surface defects such as scratches, up to 0.005 inches deep, can be polished, then blended to avoid optical distortion. Cracks or chips in the glass panels are not repairable, and the W/WS is deemed non-serviceable and scrapped.

- a. Spot polishing is mostly performed as a manual bench-top operation using hand-held, air-powered tools, such as palm sanders, with either bonded

sheet abrasives or loose rare earth compound abrasives such as cerium oxide. Stationary polishing belts are also available. However, it is not feasible to manually feed a 60-70 pound windshield for any length of time. Polishing is a messy operation because it is usually done wet, requiring much manual effort and skill, and it relies extensively upon operator experience.

Manual glass surface polishing on strengthened (tempered) glass is not widely performed outside of the aircraft industry because it is time consuming and the success is low due to the ease of introducing optical distortion. Aside from airplane W/WS, it is generally cheaper to replace a scratched W/WS than it is to polish it. For a 0.005-inch deep scratch, the defect would have to be "feathered out" over a width of ± 3.82 inches to preserve an optical deviation of 4.5 arc minutes, the standard for C/KC-135 #1 W/WS in the center viewing area of the W/WS. For a relatively large flat W/WS (B-52 center W/WS) polishing may take in excess of 12 hours.

- b. In exceptional cases, where a new W/WS is very expensive, a scratched front glass ply and the underlying vinyl can be removed and replaced. The criterion for whether or not this operation is justified is the new W/WS cost versus polishing cost versus ply replacement cost.

4) Seals and bumpers.

Seals on all W/WS are replaced and bumpers are cleaned up or repaired. The seals on the W/WS are either of the cast-in-place type, or the glue-on type. To replace a seal, the old one must first be peeled off and the W/WS frame surface cleaned, and a new seal installed.

The exposed edges of the glass, in some W/WS designs are protected with a vinyl, vinyl and rubber, or all rubber bumper either integral with the W/WS or glued on with adhesive. If the bumper has separated from the glass or if sealant that overcoats the bumper is damaged, the old sealant is removed by cutting and scraping and new sealant is reapplied to ensure that the W/WS is moisture-tight.

3.0 REPAIRED GLASS COCKPIT W/WS PERFORMANCE DATA

3.1 Program Prototype Repair W/WS

OC-ALC made arrangements to have 75 C/KC-135 W/WS that were removed from fleet aircraft at Tinker AFB shipped to Battelle as prototype repair candidates. Over 100 W/WS were screened to find the 75 prototype repair candidates. At the time of their removal, the W/WS were judged not serviceable per the criteria of the applicable C/KC-135 Fuselage Window Tech Order^[3]. Indicated reasons for removal from service included: failed heaters, bubbles, scratches, separation, leaks, old, discolored, and corrosion. The set of 75 consisted of a mixture of #1 through #5 pilot-side and copilot-side W/WS.

OC-ALC supplied 118 B-52 W/WS to Battelle by having them removed from retired aircraft at AMARC. The W/WS consisted of pilot-side and copilot-side #1, #2, and escape hatch W/WS. Unlike the C/KC-135 W/WS, the B-52 W/WS were not removed from the flight line for cause. Rather, they were taken from retired aircraft that had been on active duty.

After the B-52 W/WS were removed from the aircraft and shipped to Battelle, the W/WS were evaluated to see if they were suitable for repair. In spite of the fact that the W/WS had not been removed for cause and were on previously active duty aircraft, 67 of the W/WS were found to be out of specification on heater or sensor resistance, or else the glass was chipped. The unreparable W/WS were destroyed and the remaining 51 formed the pool from which repair candidates were selected.

The service history of the prototype repair candidates is not known because: 1) very few of the W/WS had airframe numbers, 2) the Air Force does not track W/WS by serial number, and 3) planes are moved from location to location as a part of normal squadron rotation. In most instances, the date of removal from service was not noted. The installation date is not known for any of the W/WS. All that is known for certain is the year the W/WS was made; the first one or two digits of the serial number indicate the year the W/WS was made - a single digit is a 1970's vintage W/WS.

3.2 Prototype W/WS Repairs

There currently are five prominent commercial aircraft W/WS repair stations: NORDAM Transparency Division; Perkins Aircraft Services, Inc.; The Glass Doctor; PPG Industries, Inc. Aircraft Products Division; and Pilkington Aerospace, Inc. Each of these companies has developed the necessary techniques and skills to become an FAA-certified W/WS repair station. In all cases, the concepts involved in their repair processes are as simple as described above. The actual reduction to practice of the concepts, however, is either treated as a trade secret or is covered by patents.

Prototypical repairs were made by commercial W/WS repair vendors. The W/WS repair vendors used in this program were paid for their services. The repairs were made at the vendors' prevailing commercial rates, with vendors selected by competitive bid.

Quotations for repairing C/KC-135 W/WS were solicited in October 1991 from NORDAM, Perkins, and The Glass Doctor. Terms and conditions for a site visit and repair of a number of W/WS were successfully negotiated with NORDAM and Perkins.

The set of 75 C/KC-135 W/WS was divided, and half sent to NORDAM and half sent to Perkins. Each vendor evaluated the repairability of the W/WS that they were sent and provided a quotation for repairing each W/WS. In conjunction with Battelle engineers, a subset of the 75 W/WS was selected for repair. Perkins repaired 7 #1 W/WS and 2 #4 W/WS. NORDAM repaired 8 #1's and 8 #4's.

Quotations for repairing B-52 W/WS were solicited in August 1994 from NORDAM, Perkins, The Glass Doctor, PPG, and Pilkington. Contracts for making repairs were negotiated with The Glass Doctor and PPG.

The Glass Doctor and PPG were each sent 7 #1, 7 #2, and 3 escape hatch W/WS for repair. From the W/WS sent, each vendor was to repair 4 #1, 4 #2, and 2 escape hatch W/WS, as mutually selected by Battelle and the vendor. PPG repaired the contracted number. The Glass Doctor repaired all of the W/WS sent to them (17) for the contracted price of 10.

Table 3.1 and 3.2 provide details of the prototype repairs made to the #1 and #4 C/KC-135 W/WS that were subsequently tested. W/WS that have serial numbers that begin with numbers were made by PPG, while those that start with letters were made by Libbey-Owens-Ford. In several instances, there were discrepancies between serial numbers that were recorded during inspections by various parties. These serial numbers are noted with question marks.

To fill out the test matrix, unrepaired W/WS were included in the test program, one #1 and six #4's. The original intent was to have a balanced number of repairs from each vendor and a balance in the types of repairs made. Unfortunately, it did not work out this way, because Perkins got a disproportionately large number of unrepairable W/WS. Because the performance of unrepaired W/WS provides a baseline for as-removed condition, including them in the test matrix was useful.

Tables 3.3 through 3.5 provide the details of the condition of the repair prototype B-52 W/WS and the subsequent repairs that were made to them. In the list, two items are worthy of special mention. First, The Glass Doctor made delamination repairs on the W/WS by injecting clear adhesive into the W/WS. Second, on one #1 and one #2 W/WS, The Glass Doctor did a sensor replacement.

3.3 Performance Data

3.3.1 Test Procedures

The test plan was developed as a joint effort between Battelle, OC-ALC, and the Flight Dynamics Laboratory at Wright-Patterson AFB. The Air Force does not own the Boeing 707 airframe design on which the C/KC-135 is based, so they do not have W/WS drawings and the W/WS design specifications or W/WS vendor qualification test protocols. For the B-52, the Air Force owns the design and thus has drawings and all W/WS design and test specifications. Upon reviewing the available B-52 W/WS information, it became clear that the B-52 W/WS

design predates specification of anything but pressure load integrity. Thus, the B-52 specifications were only of limited value. The test plan, therefore, was developed from the C/KC-135 and B-52 Technical Orders^{3,4} and the open literature on W/WS testing. All testing was performed at PPG Industries in Huntsville, Alabama.

In order to assess whether the performance of repaired W/WS is satisfactory, a standard for comparison must be defined. Obviously, the performance of new W/WS should be the basis for the comparison. Simply stated, the repaired W/WS should, ideally, perform just like new W/WS. In the best situation, information for new W/WS would be available to define the required tests for the repaired W/WS and the existing new W/WS data would form the basis for the comparisons. The information available from Boeing and OC-ALC suggested that data on prior C/KC-135 and B-52 W/WS testing was sparse or very difficult to retrieve, so the scope of the testing program had to include tests of new W/WS to generate the baseline new W/WS performance data. In addition, because of uncertainty in setting some of the parameters for the tests (load levels, primarily), the test program included a methodology phase verification to establish that the new W/WS would pass the tests. Although testing of new W/WS was primarily a response to the lack of readily available new W/WS test data, it does facilitate the process of making the comparisons because both new and repaired W/WS were tested under identical conditions.

3.3.2 Test Results

Three major types of tests were conducted on the repaired prototype W/WS and the companion new W/WS:

- A thorough visual/electrical/optical inspection
- Pressure/thermal cycles
- Bird impact testing.

Tables 3.6 through 3.10 summarize the conditions for the various tests. The repaired prototypes and new W/WS were all given the inspections and then a fraction of the W/WS was subjected to each of the other two types of tests. Complete details of the testing can be found in References 4 and 5.

Tables 3.11 through 3.12 summarize the safety-relevant results of the general inspections. In a number of areas, the repaired W/WS are the equivalent of new W/WS. There are, however, some troublesome areas - seals, unremoved delaminations, residual scratches, some insulation integrity faults, and a few out of specification heater resistances that suggest that the repaired W/WS are not up to OEM standards for a new W/WS.

The results of the pressure integrity testing are summarized in Tables 3.13 and 3.14. None of the W/WS, repaired, not repaired, or new, exhibited any catastrophic failures. Some of the repaired W/WS did experience delaminations, and evidence of delamination was detected in the new B-52 W/WS. Figure 3.1 shows the worst delamination that occurred in

any of the W/WS tested. In this figure, the edge of the delamination has been outlined with a black marker. None of the W/WS exhibited delamination that would cause the pilot to be unable to see through the W/WS.

A summary of the bird impact test results is presented in Tables 3.15 and 3.16. A gradation in impact damage is shown in Figures 3.2 to Figure 3.4, ranging from catastrophic failure to only a broken front ply. Other W/WS with similar damage look about the same as these figures.

4.0 HAZARD ANALYSIS RESULTS

Four safety-related failure modes have been identified for repaired glass cockpit aircraft W/WS:

- Poor optical performance
- Failure to adequately de-ice/defog
- Delamination
- Bird impact damage.

The characteristics and consequences of each failure mode have been assessed and are summarized below.

In assessing risks, the standard of comparison is a new W/WS. There are no hard data to support a statistically-based probability of failure, so probabilities are ranked as low, medium, and high.

4.1 Poor Optical Performance

4.1.1 Failure Mode

Poor optical performance is failure of the W/WS to provide an unobstructed, clear and true view of the ground/sky. Characteristics that describe this failure mode include optical distortion, W/WS scratches, and haziness/cloudiness in the W/WS caused by degradation of the vinyl interlayer.

4.1.2 System Events Phase

Poor optical performance can occur during any phase of a mission.

4.1.3 Effect on System

Poor optical performance can degrade the external visual information available to the pilot. Optical distortion can make features appear to be located at positions that do not correspond to the actual location. Scratches may appear to scintillate when light reflects off of the scratch. Haziness/cloudiness reduces the apparent brightness of scenes external to the aircraft. In the extreme, the W/WS can become completely opaque.

The net effect of poor optical performance can range from a mere annoyance to the pilot to conditions that can cause the complete loss of a plane. Optical distortion, for instance, may make vision appear blurry, or it could cause a pilot to incorrectly identify the position of landing lights.

Scratches may appear as occasional bright flashes in the pilot's eyes. This distraction, if it occurred during landing, might cause the pilot to be inattentive to tasks essential to successfully landing the plane. Haziness/cloudiness will cause the pilot to strain to see out the W/WS, much as one strains to see things in foggy driving conditions. This can increase pilot fatigue on long missions, with a potential consequence of the pilot being unable to mentally focus on mission-critical tasks.

4.1.4 Risk Assessment

The risk of repaired W/WS exhibiting poor optical performance when compared to new W/WS is high. Based on the data, It is virtually certain that there will be residual scratches in repaired W/WS and that there will be some optical distortion introduced in the repaired W/WS by virtue of the W/WS having been polished. The risk of having haziness is also high due to the chance of incomplete repair or, more likely, due to age of the W/WS.

The probability of loss of a plane due to poor optical performance is low because pilots will complain about the W/WS before the optical performance becomes degraded to the point where it can significantly alter their performance.

4.1.5 Recommended Action

A rigorous Q/A inspection program for W/WS coming back from being repaired will cull out some W/WS that could cause problems. In addition, maintenance crews should be put on alert to the fact that repaired W/WS are being used and that even minor complaints by pilots about the optical performance of repaired W/WS should be addressed immediately. By replacing at the earliest sign of trouble, the chance that the W/WS will degrade dramatically in a critical situation is eliminated.

4.2 Failure to Adequately De-ice/Defog

4.2.1 Failure Mode

Failure to adequately de-ice/defog is the result of failure of the heating system in the W/WS. Heating system failure can manifest itself as formation of frost or fog on all or some of the W/WS. The root causes of failure of the W/WS portion of the heating system failure are shorting of the W/WS busbars, failure of the temperature regulating sensor, shorting of the heater film, delamination of the glass ply where the heater film is located, and inadequate heating due to increasing W/WS heater film resistance with age.

4.2.2 System Events Phase

Failure to adequately de-ice/defog can occur at any phase of a mission.

4.2.3 Effect on System

The effect of inadequate de-icing/defogging is obstruction of the pilot's view outside the airplane. Such obstruction may be partial or it may be total. In the event of a total obstruction, the pilot may be unable to complete a mission that requires visual identification of some feature.

4.2.4 Risk Assessment

The risk of a heating system failure in a repaired W/WS is high when compared to a new W/WS. The data suggests that some W/WS were returned by vendors as being repaired in spite of the fact that they did not meet resistance specifications. In addition, some of the repaired W/WS had hot/cold spots. These W/WS will precipitate pilot complaints.

The probability of losing a plane due to heating system failure is low. Generally, such failures are progressive and the pilot will complain about the W/WS before it becomes a critical issue. The probability of having some sort of heating system problem in repaired W/WS is high by virtue of the fact that W/WS that will be repaired are generally older, and the bus resistance usually goes up as W/WS age. Eventually the resistance will get high enough that not enough power can be dissipated to adequately de-ice or defog.

4.2.5 Recommended Action

A strict Q/A program for selecting repair candidate W/WS to be sent to repair vendors will eliminate most of the W/WS with unsatisfactory resistances. In addition, Q/A monitoring of the W/WS returned by the vendors for resistance and insulation integrity should remove most of the potentially troublesome W/WS before they are put into service. The effects of long-term degradation of resistance on repaired W/WS can be mitigated by periodic resistance checks during aircraft maintenance.

4.3 Delamination

4.3.1 Failure Mode

Delamination is separation of the layers of the W/WS at the interface between the glass and the vinyl. Delamination generally begins at the edges and moves inward to the center of the transparency. In the extreme, the layers can become completely separated.

4.3.2 System Events Phase

Delamination can occur during any stage of mission. It is most likely, however, to occur when the cockpit is at maximum differential pressure with the outside air.

4.3.3 Effect on System

The effect of delamination can range from something completely unnoticed by the pilot because it is obscured by the W/WS trim pieces in the cabin to complete loss of vision because the layers have completely separated. In the usual case, the pilot will see a reflection from the separated interface that may interfere with his ability to correctly identify and locate objects outside of the plane. In general, delamination is a progressive problem that is exacerbated by pressure and thermal cycling.

4.3.4 Risk Assessment

The risk of delamination occurring in repaired W/WS is moderate, but the probability of serious consequences is low. According to the data, most of the W/WS that were repaired had some pre-existing delamination before they were repaired. Many still had delamination even after repair. Because delamination had already started, the W/WS are prone to further delamination.

4.3.5 Recommended Action

Delamination failures can be controlled by inspection of repaired transparencies and careful attention to pilot's comments about W/WS. Because of residual assembly stresses, the delaminations in some W/WS will "heal" after the cabin pressure is removed. Maintenance crews need to be alert to this possibility.

4.4 Bird Impact Damage

4.4.1 Failure Mode

The failure mode for bird impact damage ranges from a dirty W/WS to catastrophic failure of the whole transparency with penetration of the bird into the cockpit. Between these two extremes, the outer only or both glass plies may break.

4.4.2 System Events Phase

Bird impacts are most likely to occur during takeoff or landing and during low-level, high-speed flight. The consequences of a bird impact are a function of the impact velocity and angle of incidence of the impact. Higher velocities and a more direct hit result in greater damage.

4.4.3 Effect on System

The consequences of a bird impact can range from frightening the pilot to serious personal injury to the pilot to complete loss of a plane and crew. In the first case, the pilot

will certainly be frightened by a impact even if the W/WS is not structurally damaged. Vision may be temporarily obscured by bird residue and bird residue may enter the cockpit between the W/WS and its mounting frame.

The next level of system effect would be permanent obstruction of vision from a failed outer glass ply. If the bird impact was on the W/WS directly in front of the pilot and if the plane was in a critical phase of a mission such as landing, the plane and crew could be lost unless the co-pilot was immediately ready to take over.

The third level of consequences of a bird impact would be failure of both glass plies. In this situation, shards of glass would hit the pilot, perhaps injuring him seriously enough that he could no longer fly the plane.

At the extreme, there could be a complete W/WS failure in which the bird penetrates the cockpit. For the W/WS in front of the pilot, the pilot would almost certainly be fatally injured by the bird and flying glass. If the cabin was pressurized at the time of the impact, members of the crew and their equipment could be ejected from the broken W/WS opening if they were not adequately secured. Loss of the crew and plane is not out of the question.

4.4.4 Risk Assessment

The probability of a bird impact on a cockpit W/WS is quite low relative to the number of missions flown; therefore, the overall risk is low. Assuming, however, that such an event takes place, the data suggest that the risk of a bird impact on a repaired W/WS will be significantly higher than the risk for a bird impact on a new W/WS.

4.4.5 Recommended Action

The way to mitigate the added risk of a bird impact on a repaired W/WS is to only use new W/WS. There is no way to screen repaired W/WS to determine their susceptibility to bird impact damage. Age alone is not an adequate discriminator.

4.5 Status

The decision on whether or not to use repaired glass cockpit W/WS has not yet been made. Thus, none of the recommended actions has been implemented.

5.0 REFERENCES

- 1) Keslar, Leroy D. and Rankin, John S., U.S. Patent # 3,311,517, "Method of Laminating Transparent Assemblies", March 28, 1967.
- 2) Forler, C. Richard, *et al*, U.S. Patent # 4,780,162, "Methods for Repairing Laminates", October 25, 1988.
- 3) T.O. 1C-135(K)A-2-2, "Ground Handling, Servicing, and Airframe", Section VIII - Fuselage Windows, Paragraph 8-90.
- 4) T.O. 1B-52B-2-2, "Ground Handling, Servicing, and Airframe Maintenance", Section XI - Fuselage Windows, Paragraph 11-8B.
- 5) Olson, Richard J., "Development of Repair Processes and Sources for C/KC-135 Aircraft Windows/Windshields", Technical Report for 09/91-01/94 to Oklahoma City Air Logistics Center, Contract FO9603-90-SD-2217-SD02, September 1994.
- 6) Olson, Richard J., "Development of Repair Processes and Sources for B-52 Aircraft Windows/Windshields", Technical Report for 09/91-12/95 to Oklahoma City Air Logistics Center, Contract FO9603-90-SD-2217-SD02, February 1996.

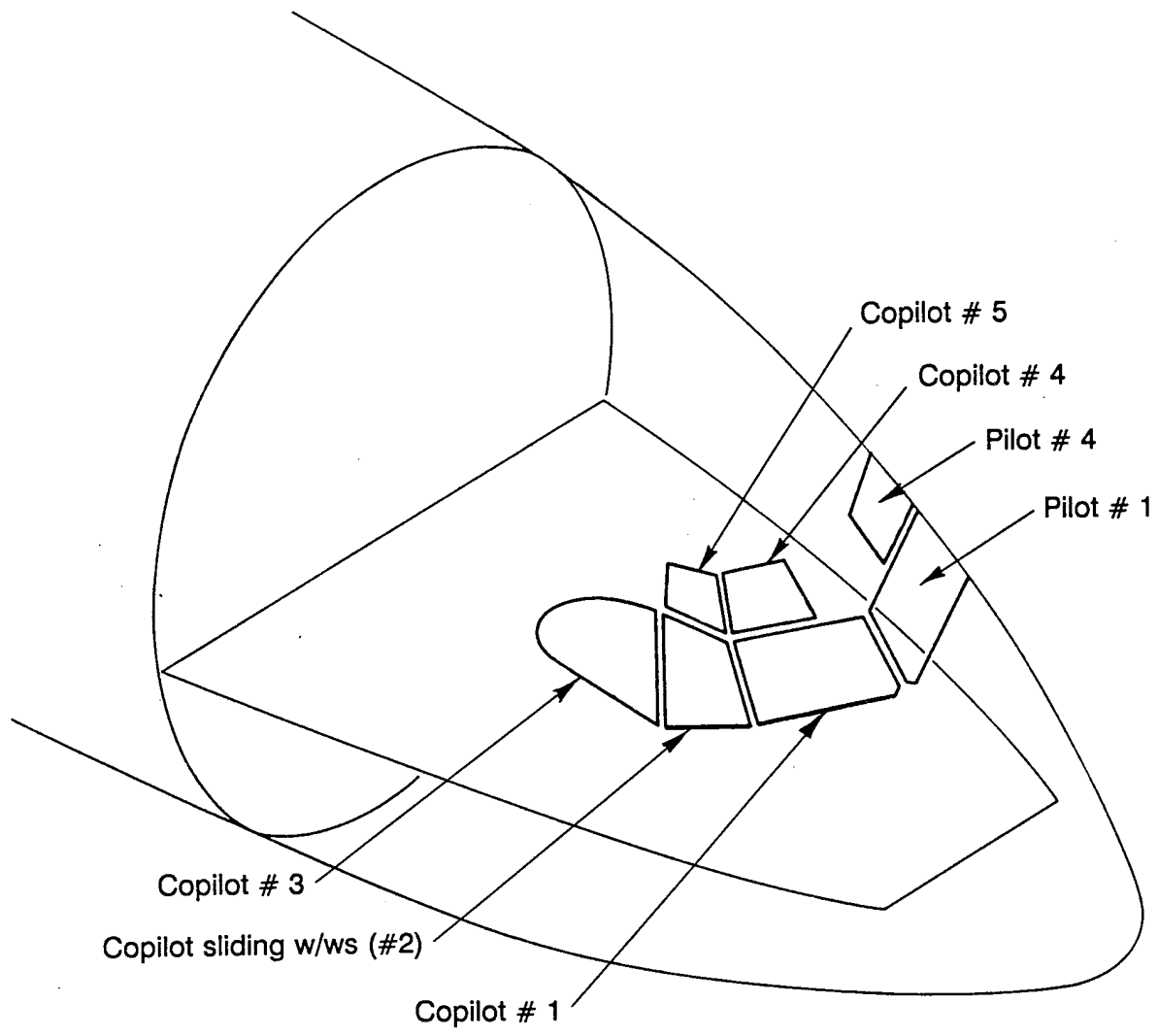

Figure 2.1 C/KC-135 W/WS Identification

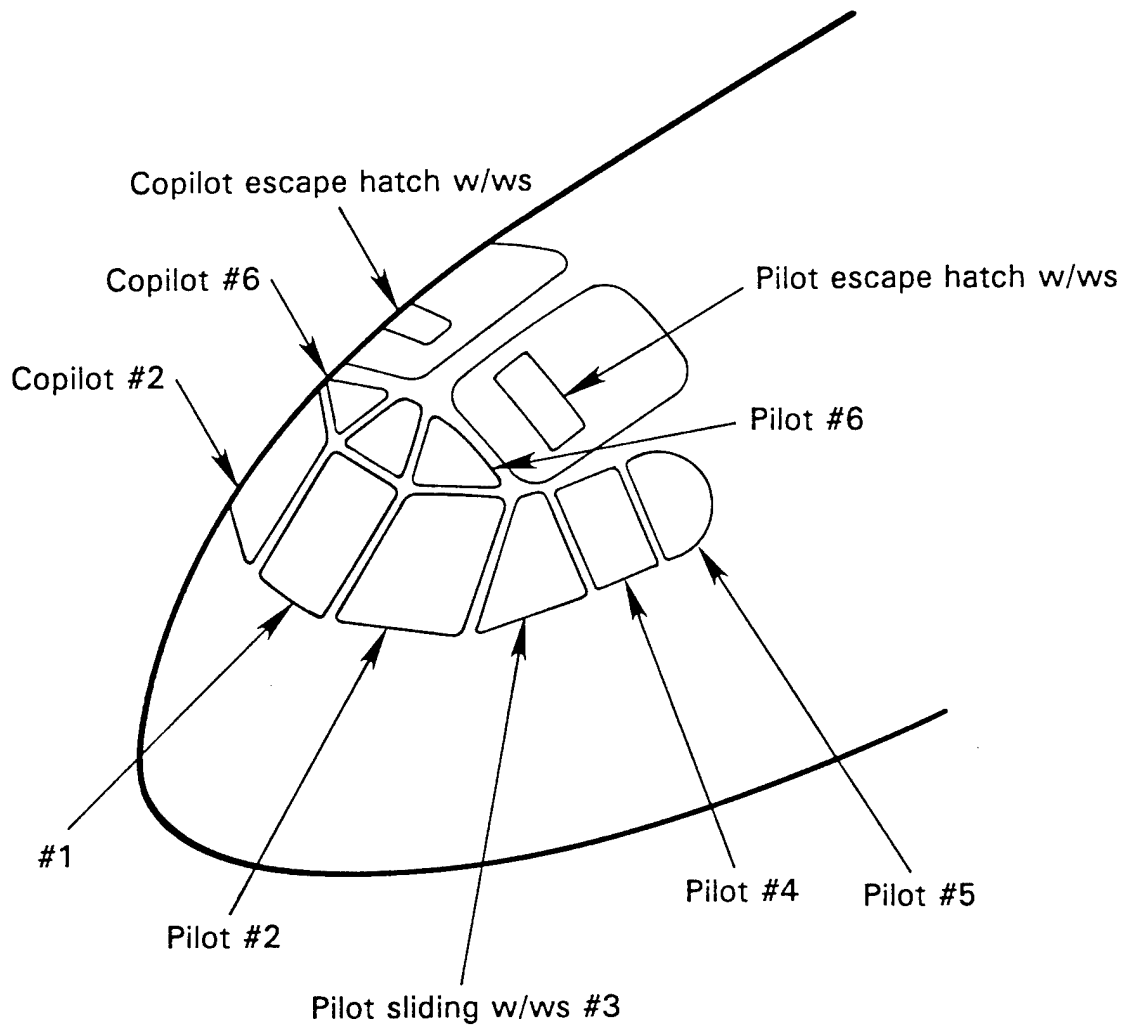

Figure 2.2 B-52 W/WS Identification

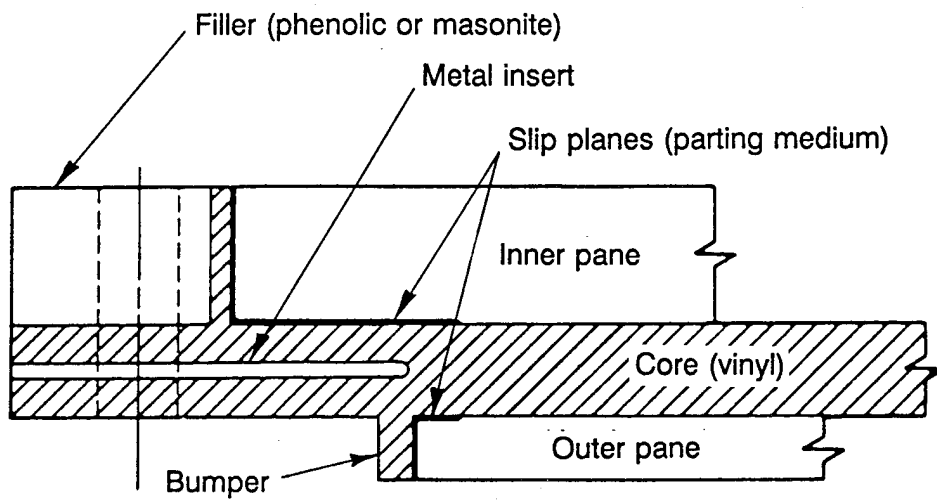
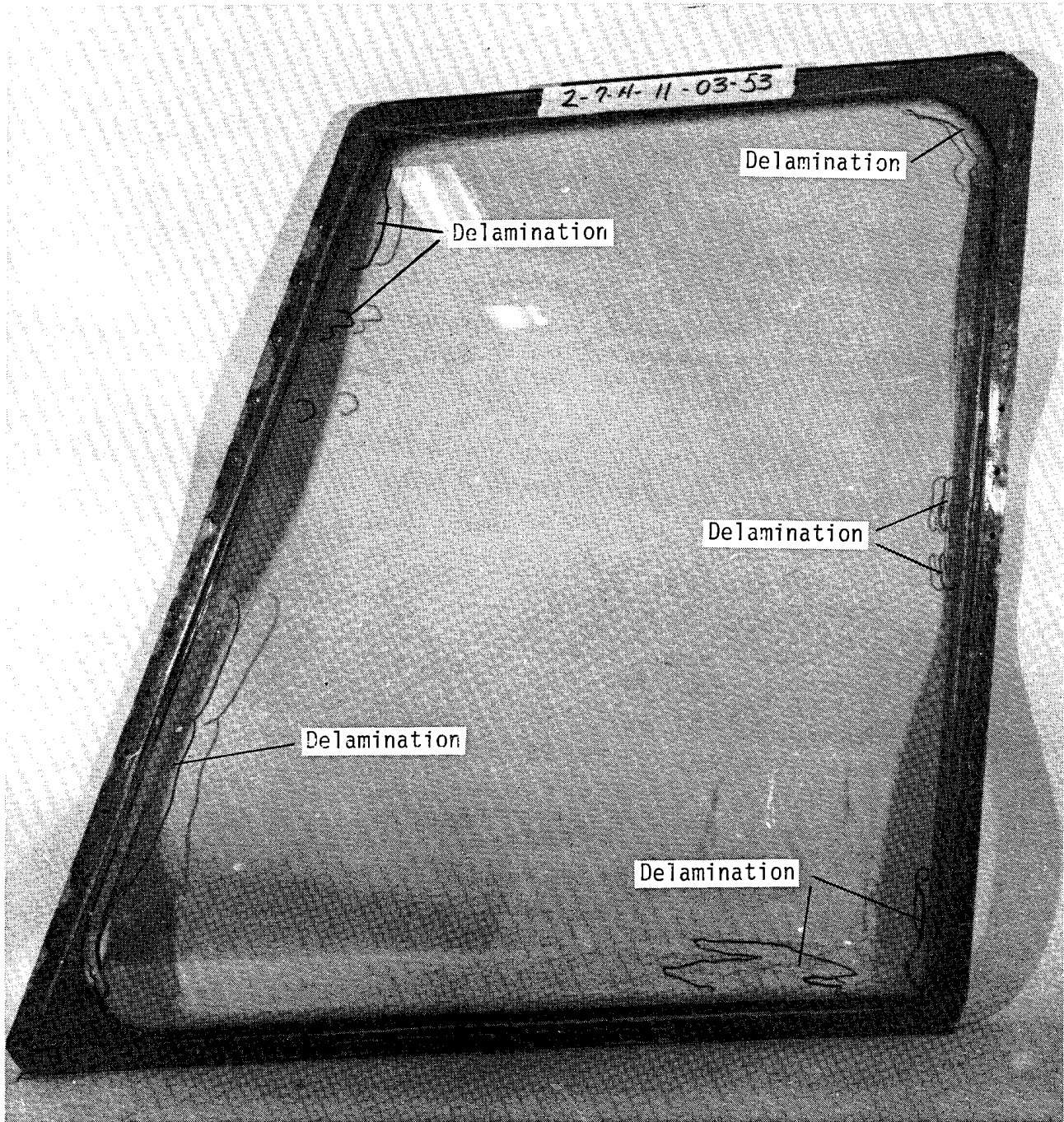

Figure 2.3 C/KC-135 and B-52 W/WS General Construction



**Figure 3.1 Worst Delamination Observed in all Pressure/Thermal Cycle Tests
(B-52 #1 W/WS, S/N 7-H-11-03-53)**

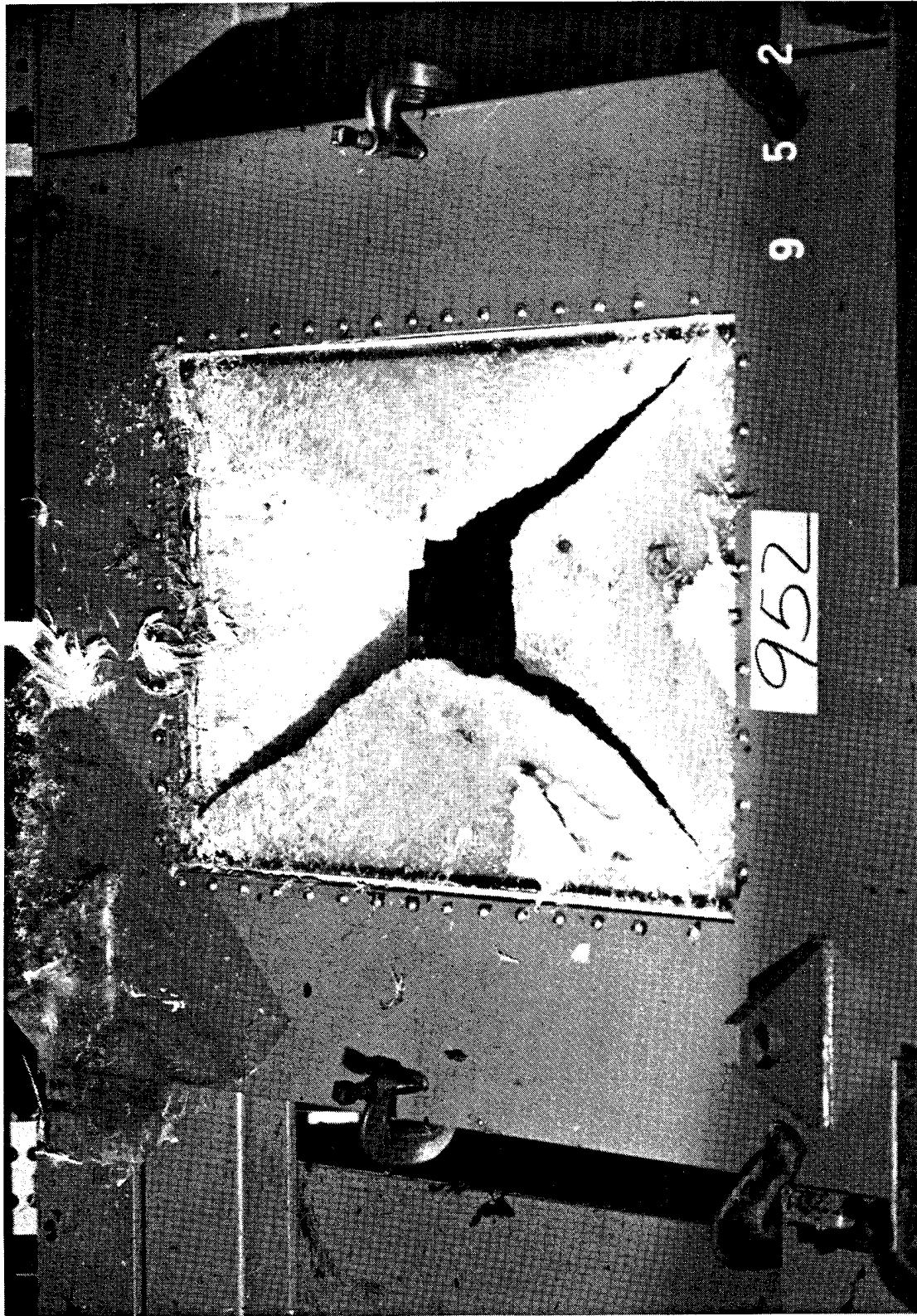

Figure 3.2 Catastrophic W/WS Failure From a 4-Pound Bird Impact at 250 Knots
(B-52 #1 W/WS, S/N 86-H-04-28-693)

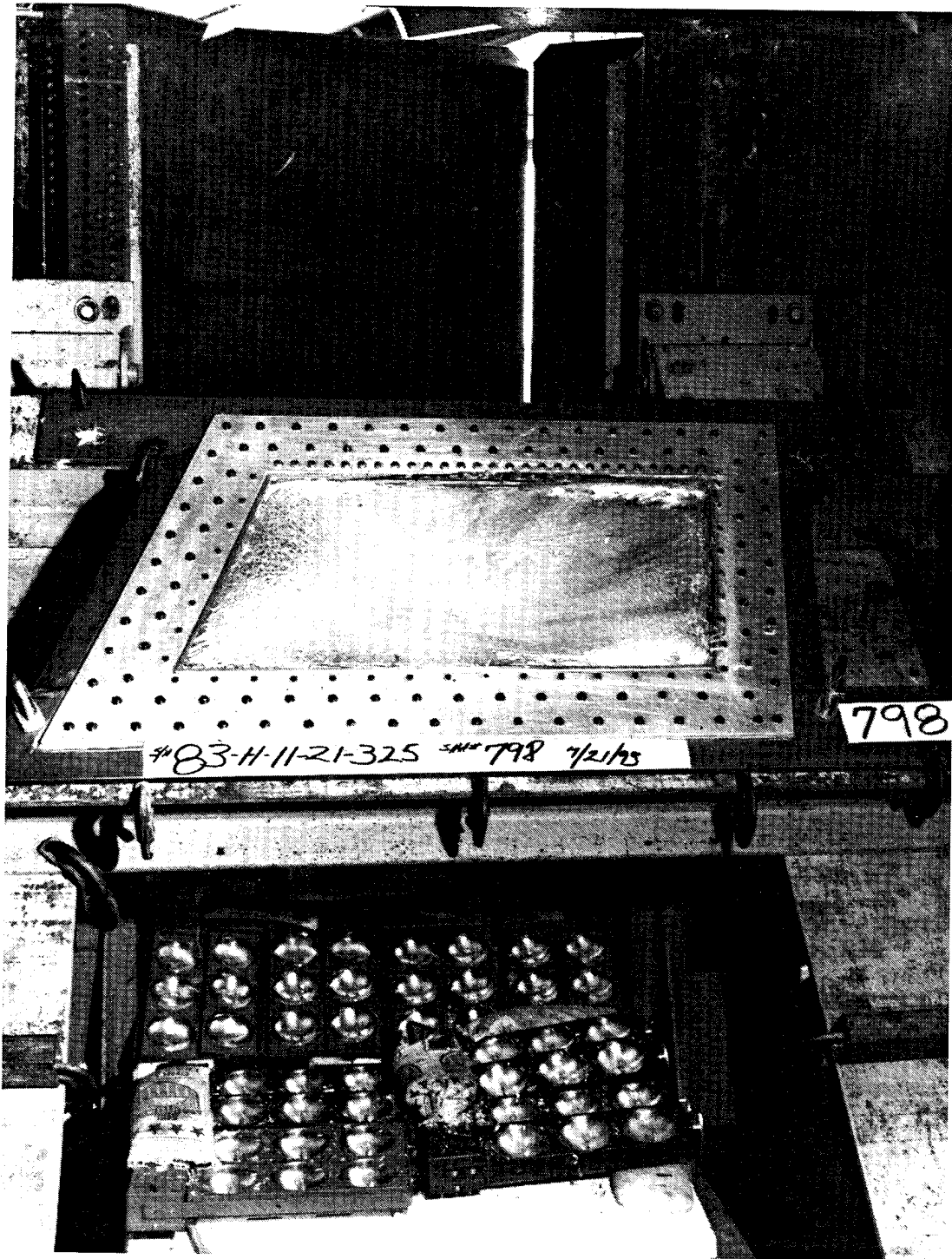

Figure 3.3 Both Glass Plies Failure From a 4-Pound Bird Impact at 250 Knots
(C/KC-135 #1 W/WS, S/N 83-H-11-21-325)

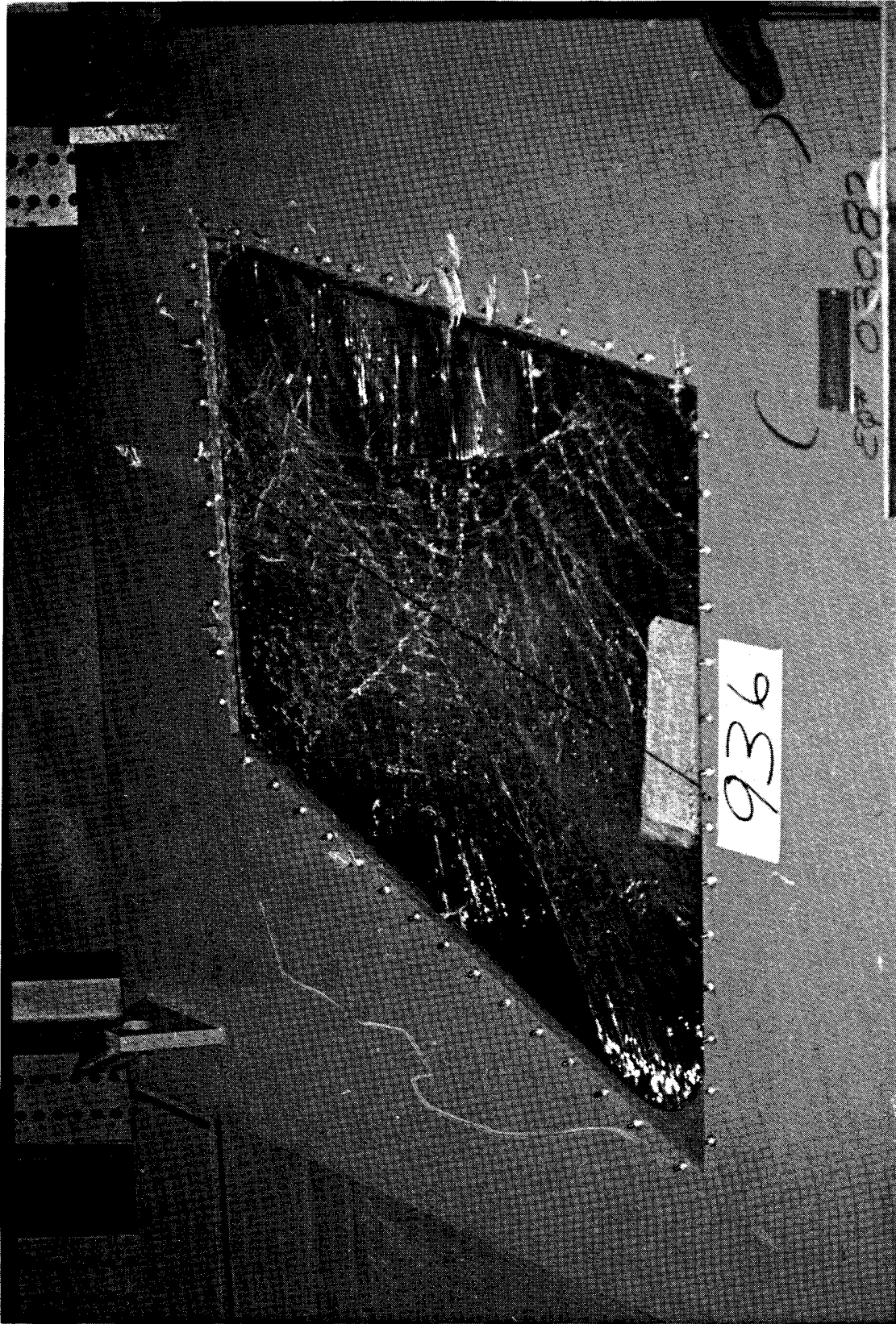

Figure 3.4 Broken Outboard Glass Ply Failure From a 4-Pound Bird Impact at 300 Knots
(B-52 #2 W/WS, S/N 5-H-3-20-17)

Table 2.1 C/KC-135 W/WS Part Numbers

Designation	NSN	Part Number
#1 Pilot	1560-01-048-1885 FL	5-89354-501
#1 Copilot	1560-01-048-1786 FL	5-89354-502
#2 Pilot	1560-01-009-3320 FL	5-89355-501
#2 Copilot	1560-01-008-7396 FL	5-89355-502
#3 Pilot	1560-00-575-6302 FL	5-89356-501
#3 Copilot	1560-00-575-6297 FL	5-89356-502
#4 Pilot	1560-00-575-6299 FL	5-71764-501
#4 Copilot	1560-00-575-6298 FL	5-71764-502
#5 Pilot	1560-00-575-6300 FL	5-89358-501
#5 Copilot	1560-00-575-6301 FL	5-89358-502

Table 2.2 B-52 W/WS Part Numbers

Designation	NSN	Part Number
#1 Center	1560-00-738-2714 FG	10-30347-7
#2 Pilot	1560-00-512-0731 FG	10-30347-1
#2 Copilot	1560-00-512-0732 FG	10-30347-2
#3 Pilot	1560-00-533-1797 FG	10-30347-3
#3 Copilot	1560-00-612-2865 FG	10-30347-4
#4 Pilot	1560-00-512-0735 FG	10-30347-5
#4 Copilot	1560-00-055-6758 FG	10-30347-6
#5 Pilot	1560-00-626-2995 FG	10-1389-37
#5 Copilot		
Escape Hatch Pilot	1560-00-630-4218 FG	10-1657-19
Escape Hatch Copilot	1560-00-652-2833 FG	10-1657-20

Table 3.1 C/KC-135 #1 W/WS Repairs

S/N	Repair Vendor	Vendor Damage Comments	Vendor Repair Comments
1-H-10-5-480	Perkins	delaminated, scratched	
82-H-10-18-105		delaminated, scratched	
82-H-10-18-107		delaminated	
83-H-8-15-756		delaminated	
83-H-9-19-282		delaminated	
83-H-9-19-294		delaminated	not repairable
83-H-11-7-432(5?)		delaminated	
84-H-3-19-220		delaminated, scratched	
82-H-9-6-235	NORDAM	scratches	polish, replace bumper and pressure seal
82-H-9-6-537		scratches	polish, replace bumper and pressure seal
82-H-12-6-431		scratches and chips	polish, replace bumper and pressure seal
83-H-9-19-459		scratches and chips	polish, replace bumper and pressure seal
83-H-11-21-325		scratches and chips	polish, replace bumper and pressure seal
86-H-12-01-146		scratches and chips	polish, replace bumper and pressure seal
88-H-02-08-436		scratches	polish, replace bumper and pressure seal
89-286-HO-697		scratches	polish, replace bumper and pressure seal

Table 3.2 C/KC-135 #4 W/WS Repairs

S/N	Repair Vendor	Vendor Damage Comments	Repair Comments
4-H-10-9-69	Perkins	contaminated	not repairable
6-H-12-02-36		bad resistance	not repairable
8-H-2-06-585		delamination, scratches	
82-H-12-6-392		contaminated	not repairable
90-173-HO-721		bad terminal block	
3-H-4-26-45	NORDAM	delamination, scratches, and chips	polish, autoclave, replace bumper and pressure seals
4-H-9-28-87		scratches	polish, replace bumper and pressure seals
4-H-10-15-108		delamination, scratches, bad resistance	not repairable
B75-1149		scratches	polish, replace bumper and pressure seals
5-H-5-23-84		delamination, scratches, bad resistance	not repairable
5-H-12-16-47		delamination, scratches	polish, autoclave, replace bumper and pressure seals
7-H-2-4-35		scratches, bad resistance	not repairable
84-H-10-15-1225		delamination, scratches	polish, autoclave, replace bumper and pressure seals
85-H-07-01-276		scratches	polish, replace bumper and pressure seals
85-H-07-01-366		scratches	polish, replace bumper and pressure seals
87-H-04-20-130		scratches	polish, replace bumper and pressure seals

Table 3.3 B-52 #1 W/WS Repairs

S/N	Repair Vendor	Vendor Damage Comments	Vendor Repair Comments
7-H-1-28-92	The Glass Doctor	-	delamination, polish, seals
83-H-3-21-110		-	delamination, polish, seals
86-H-03-03-298		-	delamination, polish, seals
86-H-04-28-693		-	delamination, replacement sensor, polish, seals
87-H-11-02-614		-	delamination, polish, seals
89-116-HO-366		-	delamination, polish, seals
89-216-HO-298		-	delamination, polish, seals
83-H-3-21-109		PPG	bad bumper/seal, surface scratches, clean
87-H-11-02-396	bad seal/bumper, delamination, clean		repair bumper, clean and inspect
89-H-137-HO-152	bad seal/bumper, clean		repair bumper, clean and inspect
92-288-HO-631	bad seal/bumper, surface scratches (grind & polish required), clean		distortion O.K., repair bumper, clean and inspect

Table 3.4 B-52 #2 W/WS Repairs

S/N	Repair Vendor	Vendor Damage Comments	Vendor Repair Comments
5-H-3-20-17	The Glass Doctor	-	delamination, polish, seals
7-H-11-03-53		-	delamination, polish, seals
8-H-11-20-277		-	delamination, polish, seals
8-H-11-20-436		-	delamination, polish, seals
85-H-07-15-044		-	delamination, replacement sensor, polish, seals
86-H-07-14-260		-	delamination, polish, seals
91-277-HO-574		-	delamination, polish, seals
1-H-11-2-571	PPG	delamination, bad bumper/seal, surface scratches,	polish, polishing distortion, repair bumper clean and inspect
5-H-3-04-09		bad seal/bumper, surface scratches, clean	polish, distortion OK, repair bumper, clean and inspect
86-H-05-12-588		bad bumper/seal, clean	repair bumper, clean and inspect
88-H-06-27-021		surface scratches, rubs, clean	polish, polishing distortion, repair bumper, clean and inspect

Table 3.5 B-52 Escape Hatch W/WS Repairs

S/N	Repair Vendor	Vendor Damage Comments	Vendor Repair Comments
84-H-11-19-090	The Glass Doctor	-	delamination, polish, seals
85-H-02-18-621		-	delamination, polish, seals
87-H-05-04-554		-	delamination, polish, seals
88-H-09-19-253	PPG	bad seal, clean	polish, polishing distortion, clean retainer
92-100-HO-683		bad seal, surface scratches, clean	polish, polishing distortion, clean retainer

Table 3.6 W/WS General Inspection Requirements

Step	Action
1	Locate and record the customer part number
2	Locate and record the W/WS serial number
3	Perform general visual inspection looking for scratches and vinyl defects
4	Conduct gasket/seal evaluation
5	Make thickness measurements at prescribed locations
6	Check physical tolerances using OEM check fixtures
7	Measure bus-to-bus resistance
8	Measure sensing element resistance
9	Perform electrical insulation integrity test
10	Perform heater operation test
11	Perform heating film scratch test
12	Make luminous transmittance and haze measurement
13	Make optical deviation measurement
14	Take optical distortion photograph

Table 3.7 W/WS Proof Pressure Test Conditions

Aircraft	Maximum Pressure, psi	Pressurization Rate, psi/minute	Hold Time, min
C/KC-135	12.6	0.84	15
B-52	18.6	1.0	15

Table 3.8 Cyclic Pressure Integrity Testing Schedule for C/KC-135 W/WS

Step	Outboard Air Temp	Inboard Air Temp	Applied Pressure	Applied Voltage	Heat Input	Maintain Conditions Until	Remarks
1	-65 F	72 F	-	-	-	temps stabilized	-
2	-65 F	72 F	-	*	-	temps stabilized	apply power to maintain W/WS temperature
3	-65 F	72 F	9.42 psi	-	-	260 cycles	0.84 psi/min pressure and depressure rate
4	70 F	72 F	-	-	-	temps stabilized	return to ambient conditions
5	Inspect for delamination						
6-10	Repeat Steps 1-5						

*

W/WS	W/WS Letter Code	Voltage, volts
#1	H1	218
	H2	210
	H3	198
#4	-	115

Table 3.9 Cyclic Pressure Integrity Testing Schedule for B-52 #1 AND #2 W/WS

Step	Outboard Air Temp	Inboard Air Temp	Applied Pressure	Applied Voltage	Heat Input	Maintain Conditions Until	Remarks
1	-65 F	70 F	-	-	-	temps stabilized	-
2	-65 F	70 F	-	*	-	temps stabilized	apply power
3	-65 F	70 F	-	*	*	deflections and temps stabilized	adjust air velocity so that heat input is dissipated without voltage cycling
4	-65 F	70 F	15 psi	-	-	250 cycles	1 psi/min pressure and depressure rate
5	-65 F	70 F	-	-	-	temps stabilized	remove power
6	70 F	70 F	-	-	-	temps stabilized	return to ambient conditions
7	Inspect for delamination						
8-14	Repeat Steps 1-7						

*

W/WS	W/WS Letter Code	Voltage, volts	Power, watts
#1	H1	330	2380
	H2	314	
	H3	298	
	H4	421	

W/WS	W/WS Letter Code	Voltage, volts	Power, watts
#2	H1	441	2600
	H2	421	
	H3	398	

Table 3.10 Cyclic Pressure Integrity Testing Schedule for B-52 Escape Hatch W/WS

Step	Outboard Air Temp	Inboard Air Temp	Applied Pressure	Applied Voltage	Heat Input	Maintain Conditions Until	Remarks
1	-65 F	70 F	-	-	-	temps stabilized	-
2	-65 F	70 F	-	161 V	-	temps stabilized	apply power
3	-65 F	70 F	10 psi	161 V	-	deflections stabilized	apply pressure
4	-65 F	70 F	10 psi	161 V	426 W	until deflections and temps stabilized	adjust air velocity so that heat input is dissipated without voltage cycling
5	-65 F	70 F	-	-	-	deflections stabilized	remove pressure, reduce air velocity to zero
6	-65 F	70 F	-	-	-	temps stabilized	remove power
7	70 F	70 F	-	-	-	temps stabilized	return to ambient conditions
8	Inspect for delamination						
9-48	Repeat Steps 1-8 five times, increasing the pressure applied at Steps 3 and 4 in 1 psi increments to a maximum of 15 psi						
49	-65 F	70 F	-	-	-	temps stabilized	-
50	-65 F	70 F	-	161 V	-	temps stabilized	apply power
51	-65 F	70 F	-	161 V	426 W	temps stabilized	see Step 4
52	-65 F	70 F	13 psi	161 V	426 W	30 minutes	apply pressure
53	-65 F	70 F	18.6 psi	161 V	426 W	30 minutes	add pressure increment
54	70 F	70 F	-	-	-	temps stabilized	return to ambient conditions
55	Inspect for delamination						

Table 3.11 C/KC-135 W/WS General Inspection Summary

Category	#1 W/WS			#4 W/WS		
	New	Repaired	Not Repaired	New	Repaired	Not Repaired
Number Tested	8	15	1	9	10	6
Number with delamination, scratches, or chips	0	13	1	0	9	6
Number with seal deficiencies	0	14	1	0	9	6
Number with vinyl cracks	0	0	1	0	2	4
Number with bad dimensional check	0	0	0	0	0	0
Number with bad bus resistance	0	0	0	0	3	3
Number with bad sensor resistance	0	0	0	-	-	-
Number with bad insulation	0	9	1	0	0	0
Number with poor heater performance	0	0	1	0	1	0
Number with optical deficiencies	0	0	0	0	0	0

Table 3.12 B-52 W/WS General Inspection Summary

Category	#1 W/WS			#2 W/WS			Escape Hatch	
	New	Repaired	Not Repaired	New	Repaired	Not Repaired	New	Repaired
Number Tested	2	11	3	2	11	3	2	5
Number with delamination, scratches, or chips	0	8	3	0	10	3	0	4
Number with seal deficiencies	0	0	3	0	0	3	-	-
Number with vinyl cracks	0	0	0	0	0	0	0	0
Number with bad dimensional check	0	0	0	0	0	0	0	0
Number with bad bus resistance	0	1	2	0	0	0	0	0
Number with bad sensor resistance	0	0	0	0	0	0	-	-
Number with bad insulation	0	1	1	0	0	0	-	-
Number with poor heater performance	0	1	2	0	0	2	0	0
Number with optical deficiencies	0	2	4	0	0	0	0	0

Table 3.13 C/KC-135 W/WS Pressure Integrity Test Summary

Category	#1 W/WS			#4 W/WS		
	New	Repaired	Not Repaired	New	Repaired	Not Repaired
Number Tested	4	7	1	4	7	1
Number failing initial proof pressure test	0	0	0	0	0	0
Number failing during pressure cycling	0	0	0	0	0	0
Number failing final proof pressure test	0	0	0	0	0	0
Number delaminated	0	2	0	0	2	0

Table 3.14 B-52 W/WS Pressure Integrity Test Summary

Category	#1 W/WS		#4 W/WS		Escape Hatch	
	New	Repaired	New	Repaired	New	Repaired
Number Tested	1	4	1	4	1	4
Number failing initial proof pressure test	0	0	0	0	0	0
Number failing during pressure cycling	0	0	0	0	0	0
Number failing final proof pressure test	0	0	0	0	0	0
Number delaminated	1	2	1	4	0	2

**Table 3.15 C/KC-135 W/WS Bird Impact Test Summary
(250 Knots, 4-Pound Bird)**

Category	#1 W/WS		#4 W/WS		
	New	Repaired	New	Repaired	Not Repaired
Number Tested	4	8	5	3	5
Number undamaged	3	2	4	2	2
Number with one glass ply broken	1	3	1	1	1
Number both glass plies broken	0	3	0	0	2
Number with no inner ply glass spall	4	5	5	3	3
Number with minor inner ply glass spall	0	3	0	0	1
Number with major inner ply glass spall	0	0	0	0	1
Number with no bird penetration	4	8	5	3	4
Number with minor bird penetration	0	0	0	0	0
Number with major bird penetration	0	0	0	0	1

Table 3.16 B-52 W/WS Bird Impact Test Summary
(4-Pound Bird)

Category	#1 W/WS										#2 W/WS		
	New	Repaired			Not Repaired			New	Repaired		Not Repaired		
Number Tested	1	1	4	1	1	1	1	1	1	5	1	1	
Velocity, knots	250	200	250	300	200	250	300	300	200	300	400	300	
Number undamaged	1	0	3	0	1	1	0	1	1	1	0	1	
Number with one glass ply broken	0	1	0	0	0	0	0	0	0	1	0	0	
Number both glass plies broken	0	0	1	1	0	0	1	0	0	3	1	0	
Number with no inner ply glass spall	1	1	3	0	1	1	0	1	1	2	0	1	
Number with minor inner ply glass spall	0	0	0	0	0	0	0	0	0	2	0	0	
Number with major inner ply glass spall	0	0	1	1	0	0	1	0	0	1	1	0	
Number with no bird penetration	1	1	3	0	1	1	0	1	1	4	0	1	
Number with minor bird penetration	0	0	0	0	0	0	0	0	0	0	0	0	
Number with major bird penetration	0	0	1	1	0	0	1	0	0	1	1	0	