

REPORT DOCUMENTATION PAGE

Form Approved
OMB No. 0704-0188

2

Public reporting burden for this collection of information is estimated to average 1 hour per response, including the time for reviewing instructions, searching existing data sources, gathering and maintaining the data needed, and completing and reviewing the collection of information. Send comments regarding this burden estimate or any other aspect of this collection of information, including suggestions for reducing this burden, to Washington Headquarters Services, Directorate for Information Operations and Reports, 1215 Jefferson Davis Highway, Suite 1204, Arlington, VA 22202-4302, and to the Office of Management and Budget, Paperwork Reduction Project (0704-0188), Washington, DC 20503.

1. AGENCY USE ONLY (Leave blank)	2. REPORT DATE 7/31/95	3. REPORT TYPE AND DATES COVERED Final Report - 9/30/94 - 5/31/95
----------------------------------	---------------------------	--

4. TITLE AND SUBTITLE Supersonic Nozzle Beam Source of Active Nitrogen for Improved Nitride Growth	5. FUNDING NUMBERS N00014-94-C-0229 3121401
---	---

6. AUTHOR(S) A. Freedman,* G.N. Robinson,* Q.Dai,* J.J. Sumakeris,** K.K. Lai,** V.M. Torres,** R.F. Davis,** H.H. Lamb**	
--	--

7. PERFORMING ORGANIZATION NAME(S) AND ADDRESS(ES) *Aerodyne Research, Inc., 45 Manning Road, Billerica, MA 01821 **Dept. of Materials Science and Engineering, North Carolina State University, Raleigh, North Carolina	8. PERFORMING ORGANIZATION REPORT NUMBER ARI-RR-1129
--	---

9. SPONSORING/MONITORING AGENCY NAME(S) AND ADDRESS(ES) Office of Naval Research 800 N. Quincy Street Arlington, VA 22217-5660	10. SPONSORING/MONITORING AGENCY REPORT NUMBER
---	--

11. SUPPLEMENTARY NOTES

12a. 19960415 042 Unlimited	12b. DISTRIBUTION CODE <div style="border: 1px solid black; padding: 5px; text-align: center;"> DECLASSIFICATION STATEMENT II Approved for public release Distribution Unlimited </div>
---	--

13. ABSTRACT (Maximum 200 words)

Hydrazoic acid was shown to be an extremely reactive molecule and an effective precursor species for 'active nitrogen'. At room temperature, hydrazoic acid dissociatively chemisorbed on GaAs(110) surfaces to form the NH radical and N₂. At 673 K, an anionic exchange mechanism commenced; the surface became completely depleted in As and a thin film of GaN formed. When the surface was dosed at 773 K, a 20 Å thick GaN film was grown. This evidence demonstrates that hydrazoic acid is highly reactive at comparatively low surface temperatures and offers a viable alternative to ammonia as a nitrogen precursor. Experiments which involved growing GaN on sapphire and silicon using a supersonic beam of ammonia and an effusive triethylgallium beam, showed distinct trends in film morphology as a function of the ammonia nozzle and substrate temperature. Stoichiometric GaN films were deposited on Al₂O₃(0001), Si(001) and Si(111) substrates. Very uniform films were achieved at low substrate temperatures. An improvement in the degree of preferred orientation in the GaN films deposited on Al₂O₃(0001) substrates with increasing nozzle temperature was observed.

14. SUBJECT TERMS gallium nitride, wide bandgap, supersonic nozzle beams, hydrazoic acid	15. NUMBER OF PAGES 36
	16. PRICE CODE

17. SECURITY CLASSIFICATION OF REPORT UNCLASSIFIED	18. SECURITY CLASSIFICATION OF THIS PAGE UNCLASSIFIED	19. SECURITY CLASSIFICATION OF ABSTRACT UNCLASSIFIED	20. LIMITATION OF ABSTRACT
---	--	---	----------------------------

56K

TABLE OF CONTENTS

1. INTRODUCTION	1
1.1 Technical Background	1
1.2 Approach	2
1.3 Phase I Technical Objectives	4
1.4 Summary of Results	5
1.5 References	6
2. GROWTH OF THIN AMORPHOUS FILMS OF GaN on GaAs (110) USING SEEDED NOZZLE BEAMS of HYDROAZOIC ACID	7
2.1 Experimental	7
2.2 Results	10
2.3 Conclusions	16
2.4 References	17
3. DEPOSITION OF GaN FILMS USING SEEDED SUPERSONIC BEAMS	19
3.1 Introduction	19
3.2 Experimental Procedure	21
3.3 Results and Discussion	23
3.4 Conclusions	33
3.5 Future Plans	33
3.6 References	34

1. INTRODUCTION

We are developing a technique called Selected Energy Epitaxy (SEE) using supersonic nozzle beam sources of 'active nitrogen' to be used in the molecular beam epitaxy (MBE) of nitride materials. The approach involves 'seeding' a heavy (and relatively inert) nitrogen precursor gas in a light carrier gas and using a supersonic expansion to accelerate the precursor molecules towards the substrate surface with an energy sufficient to cause bond dissociation. The resultant species would be a free radical and thus highly reactive. Further variation of the kinetic energy of the nitrogen precursor species by use of different carrier gases will enhance the mobility of the metal and N species necessary to produce Group III nitride monocrystalline thin films with limited defects. The ultimate goal of this work is to develop a commercially viable active nitrogen source that can be used to grow III-V materials at lower substrate temperatures. The project represents a collaborative effort between Aerodyne Research, Inc. (a small business) and North Carolina State University (a research institution) in order to pool their expertise under the auspices of the DoD Small Business Technology Transfer (STTR) program.

1.1 Technical Background

The III-V nitrides of Al, Ga and In are direct band gap semiconductors which form complete solid solutions with each other and which are candidate materials for high frequency microelectronic as well as optoelectronic devices. The latter devices would be operative within the orange (InN) to ultraviolet (GaN and AlN) range of the spectrum. However these materials, particularly GaN and InN, possess a high vapor pressure at the growth temperatures of vapor phase epitaxy (VPE) (800 - 1100°C) and molecular beam epitaxy (MBE) (500 - 700°C). The primary experimental problem is the difficulty of maintaining sufficient reactive N in the vicinity of the growing film to counteract the tendency for nitrogen loss. The use of electron cyclotron resonance plasmas has allowed the deposition temperature to be decreased in the MBE technique, but the flux of reactive N species is limited. In the case of VPE, the presence of a substantial partial pressure of ammonia, especially in the case of InN deposition, allows the growth temperature to be increased, but with a concomitant increase in the N vapor pressure from the growing nitride. The desired alternative is a system which allows for the production of copious amounts of reactive N species, deposition at reduced temperatures where the rate of vaporization is low and the availability of energy at the surface to enhance the mobility of the Al, Ga and/or In and N species to produce monocrystalline films free of substantial residual stresses. The use of supersonic jets containing a low atomic weight carrier gas seeded with a reactive N-containing gas satisfies these criteria. Implementation of this technique is the focus of this proposal.

The use of supersonic expansions to produce high energy and reasonably monoenergetic neutral species beams was pioneered by Fenn and co-workers at Yale in the 1960's.^{10,11} One of the first applications of this technology was in the study of reaction dynamics in crossed molecular beam experiments. Profs. Dudley Herschbach of Harvard and Yuan Lee of Berkeley won Nobel Prizes in Chemistry in part for their use of seeded beams to elucidate reaction mechanisms.¹² Both reaction probabilities and mechanisms were found to vary widely as a function of incident translational energy. Dr. Andrew Freedman (the proposed principal investigator at Aerodyne), for instance, was able to observe that the reaction mechanism of the nominally spin forbidden reaction of barium with sulfur dioxide changed to a direct reaction from one involving a long-lived intermediate as the reactant translational energy was increased from just 0.15 eV to 0.45 eV.¹³

The most dramatic case, though, of the role of incident translational energy in surface reactions involves the industrial process involving the conversion of methane and water to carbon monoxide and hydrogen in the presence of nickel catalysts. Using thermal gases under ultrahigh vacuum conditions, methane will not dissociate on a nickel surface; but at pressures above a Torr, dissociation is readily observed. Professor Sylvia Ceyer of MIT, was able to show in an elegant set of experiments, that the high energy tail of the thermal distribution of methane molecules was responsible for the dissociation process.¹⁴ Using seeded supersonic beams of methane, her group was able to observe the onset of methane dissociation on a Ni (110) surface at ~ 0.5 eV. Furthermore, they were able to show that the dissociation probability increased by two orders of magnitude as the incident energy was increased by only 0.25 eV. It is this effect that we will try to take advantage of in the proposed active nitrogen beam source.

1.2 Approach

The approach we take to developing a neutral active nitrogen beam source involves seeding a comparatively heavy nitrogen precursor in a light 'carrier' gas and expanding the mixture through a small orifice into a high vacuum in order to generate a supersonic beam.^{15,16} This expansion process has the effect of both significantly increasing the velocity of the heavy component and substantially narrowing the velocity distribution compared to both thermal and unseeded nozzle sources. If the beam possesses sufficient kinetic energy when it strikes the substrate, the nitrogen precursor species will dissociate upon impact producing a reactive nitrogen species which can form the nitride material. The change in the velocity profile of the molecules is the result of the gas undergoing an adiabatic expansion where all the random motion of the gas

(including both translational and rotational modes) is funneled into the forward velocity of the beam. The maximum energy of a seeded beam, E_T can be calculated as follows:

$$E_T = (m_2/m_1) C_p T_0$$

where T_0 is the source gas temperature, C_p is the heat capacity and m_1 is the mass of the seed gas, and m_2 is the mass of the nitrogen precursor. Thus it can be seen that the larger the ratio of the masses and the higher the temperature of the source gas, the greater the resultant beam energy. In order to maximize this value, we have chosen to use HN_3 , hydrazoic acid, as the nitrogen precursor. It has two major advantages over other precursors such as molecular nitrogen and ammonia: first, it is substantially heavier than the other two; and its bond dissociation energy to produce some form of active nitrogen is also much lower.

Table I. Possible Active Nitrogen Precursor Gases

<u>Nitrogen Precursor</u>	<u>Mass</u> (amu)	<u>Bond Energy</u> (eV)	<u>Products</u>
HN_3	43	0.5	$\text{NH} + \text{N}_2$
NH_3	17	4.5	$\text{NH}_2 + \text{H}$
N_2	28	9.8	$\text{N} + \text{N}$

As can be seen from Figure 2 below, the kinetic energy of the HN_3 precursor can readily be varied above and below the bond dissociation energy by using a series of common carrier gases. Furthermore, slight heating of the nozzle source will produce enough translational energy to open up the spin allowed channel:

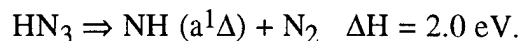

This electronically excited species should be an extremely reactive nitride-forming radical.¹⁷

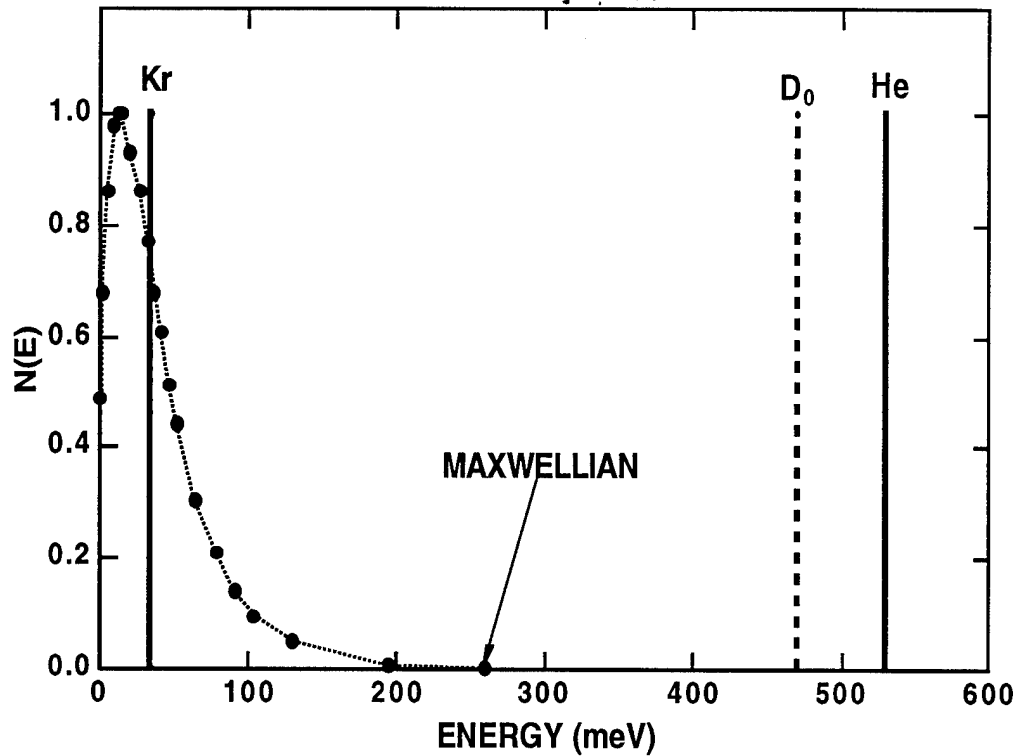

Figure 1. Kinetic Energy Distribution Of A Maxwellian Beam Of Hydrazoic Acid Versus Helium And Krypton Seeded Supersonic Nozzle Beams.

1.3 Phase I Technical Objectives

The goal of the Phase I project was to demonstrate the efficacy of supersonic nozzle beam sources of active nitrogen in producing nitride materials. To that end, Aerodyne Research (ARI) and North Carolina State University (NCSU) performed the following tasks:

Aerodyne Research, Inc.

- Designed and constructed a pulsed nozzle beam source using commercially available equipment;
- Synthesized the active nitrogen precursor, HN_3 (hydrazoic acid) ;
- Dosed gallium arsenide crystal samples with HN_3 as a function of beam energy and substrate temperature and used X-ray photoelectron spectroscopy to determine whether the growth of nitride films has occurred ;

- Analyzed the chemical composition structure and electronic properties of the GaN films using Auger spectroscopy and scanning electron microscopy using the facilities at NCSU.

North Carolina State University

- Grew gallium nitride on a variety of substrates using seeded nozzle beams of ammonia as a function on both substrate and nozzle beam temperature and
- Analyzed the resulting films using Auger spectroscopy, scanning electron microscopy and x-ray diffraction techniques.

1.4 Summary of Results

The Aerodyne experiments were able to confirm that hydrazoic acid is an extremely reactive molecule and an effective precursor species for 'active nitrogen'. At room temperature, hydrazoic acid dissociatively chemisorbed to form the NH radical and N₂. At 473 K, the NH fragment reacted with the substrate, broke Ga-As bonds and formed GaN and AsN species. At 673 K, an anionic exchange mechanism commenced; the surface became completely depleted in As and a thin film of GaN formed. When the surface was dosed at 773 K, a 20 Å thick GaN film was grown. This evidence demonstrates that hydrazoic acid is highly reactive at comparatively low surface temperatures and offers a viable alternative to ammonia as a nitrogen precursor.

The highly reactive nature of the hydrazoic acid on the GaAs surface precluded observation of any beam kinetic energy effect on the growth of the GaN films using HN₃. Samples grown with both helium and krypton seed gases were virtually identical. This result is ascribed to the lack of a substantial activation barrier to dissociation and reaction and subsequent film formation. It should be noted that this does not mean that a kinetic energy effect would not be observed on less reactive or inert surfaces and in the case of true binary film growth using an organometallic Ga precursor.

The experiments at North Carolina State University, which involved growing GaN on sapphire and silicon using ammonia and diethylgallium, showed a distinct trend as a function of the ammonia nozzle and substrate temperature. Stoichiometric GaN films were deposited on Al₂O₃(0001), Si(001) and Si(111) substrates using an NH₃ seeded free He Jet and an effusive

triethylgallium (TEG) source. Very uniform films were achieved at low temperatures. An improvement in the degree of preferred orientation in the GaN films deposited on Al₂O₃(0001) substrates with increasing nozzle temperature was observed. Work continued toward the construction of a dual supersonic beam deposition system with an attached UHV analysis system.

1.5 References

1. C.D. Stinespring, A. Freedman, and C.E. Kolb, *J. Vac. Sci. Technol. A* 4, 1946 (1986).
2. C.D. Stinespring and A. Freedman, *Appl. Phys. Lett.* 48, 718 (1986).
3. A. Freedman and C.D. Stinespring, *J. Phys. Chem.* 96, 2253 (1992)
4. A. Freedman, *J. Applied Physics*, 75, 3112 (1994)
5. J.A. Silver, A. Freedman, C.E. Kolb, A. Rahbee, C.P. Dolan, *Rev. Sci. Instrum.* 53, 1714, (1982).
6. M.J. Paisley, and R.F. Davis, *Journal of Crystal Growth* 127, 136-142 (1993).
7. M.J. Paisley and R.F. Davis, *J. Vacuum Science Technol. A* 11, 18-24 (1993).
8. D.J. Kester, K.S. Ailey, K.L. More and R.F. Davis, *Journal of Materials Research* 8, 1213-1216 (1993).
9. C. Wang and R.F. Davis, *Appl. Phys. Lett.* 63, 990-992 (1993).
10. N.Abauf, J. Anderson, R. Andres, J. Fenn, and D. Marsden, *Science*, 155, 977 (1967)
11. J.B. Anderson, R.P. Andres, and J. Fenn, *Adv. Chem. Phys.* 10, 275 (1966)
12. Y. T. Lee, *Science*, 236, 793 (1987)
13. A. Freedman, T.P. Parr, R. Behrens, Jr., and R.R. Herm, *J. Chem. Phys.* 70, 5251 (1979).
14. S. T. Ceyer, *Langmuir*, 6, 82 (1990)
15. H. Pauly and J.P.Toennies, *Methods of Experimental Physics* 7A, 237 (1968)
16. G.N. Robinson, R.E. Continetti, and Y.T. Lee, *J. Chem. Phys.* 92, 275 (1990).
17. H. Okabe, *Photochemistry of Small Molecules*, Wiley (New York,, 1978)

2. GROWTH OF THIN AMORPHOUS FILMS OF GaN on GaAs (110) USING SEEDED NOZZLE BEAMS of HYDRAZOIC ACID

In order to investigate the reactivity of hydrazoic acid, single crystal wafers of GaAs were dosed with controlled exposures of HN_3 . The crystal surface chosen for study was the non-polar (110) surface, even though it is of little technological importance. A preponderance of scientific studies have been performed on this surface since it allows one to avoid the issue of whether the surface is gallium or arsenic terminated.¹ Strong preferential etching behavior, for instance, is observed on the (111) surface depending on the surface termination.

2.1 Experimental

The microchemistry of hydrazoic acid interactions with GaAs crystal surfaces was studied in an ultrahigh vacuum apparatus shown in Figure 1. It comprises a turbomolecular pumped, liquid nitrogen trapped ultrahigh vacuum cell (ultimate vacuum - 3×10^{-10} torr) interfaced to anion/sublimation pumped analysis chamber. The diagnostics available in the analysis chamber are x-ray photoelectron spectroscopy (XPS) and low energy electron diffraction (LEED). The sample is transferred between chambers using a linear motion feedthrough with sample heating (1200 K) and cooling (130 K) capabilities.

We utilized a commercially available pulsed supersonic nozzle beam source, the General Valve Iota-1; a schematic of the source is shown in Figure 2. The valve is capable of being operated at 500 K and producing pulses as short as 200 microseconds. The maximum repetition rate is 250 Hz. The valve is constructed entirely of stainless steel and Teflon parts and is thus compatible with a clean environment. We designed and had built a vacuum sleeve and metal seal flange coupling the nozzle source to the UHV chamber which enabled us to place the substrate within 2 cm of the beam source. Base pressures of below 10^{-9} Torr were reached with the nozzle source in place, indicating that the valve had a negligible leak rate. The pulse length was set such that an individual pulse of gas delivered a dose of approximately 10^{15} molecules cm^{-2} of HN_3 to the substrate surface during each pulse. At a 10 Hz repetition rate with the helium seeded beam, an average chamber pressure of $\sim 10^{-4}$ Torr was reached. As soon as the beam was turned off, the chamber pressure rapidly returned to the 10^{-9} Torr level.

UHV SURFACE REACTION APPARATUS

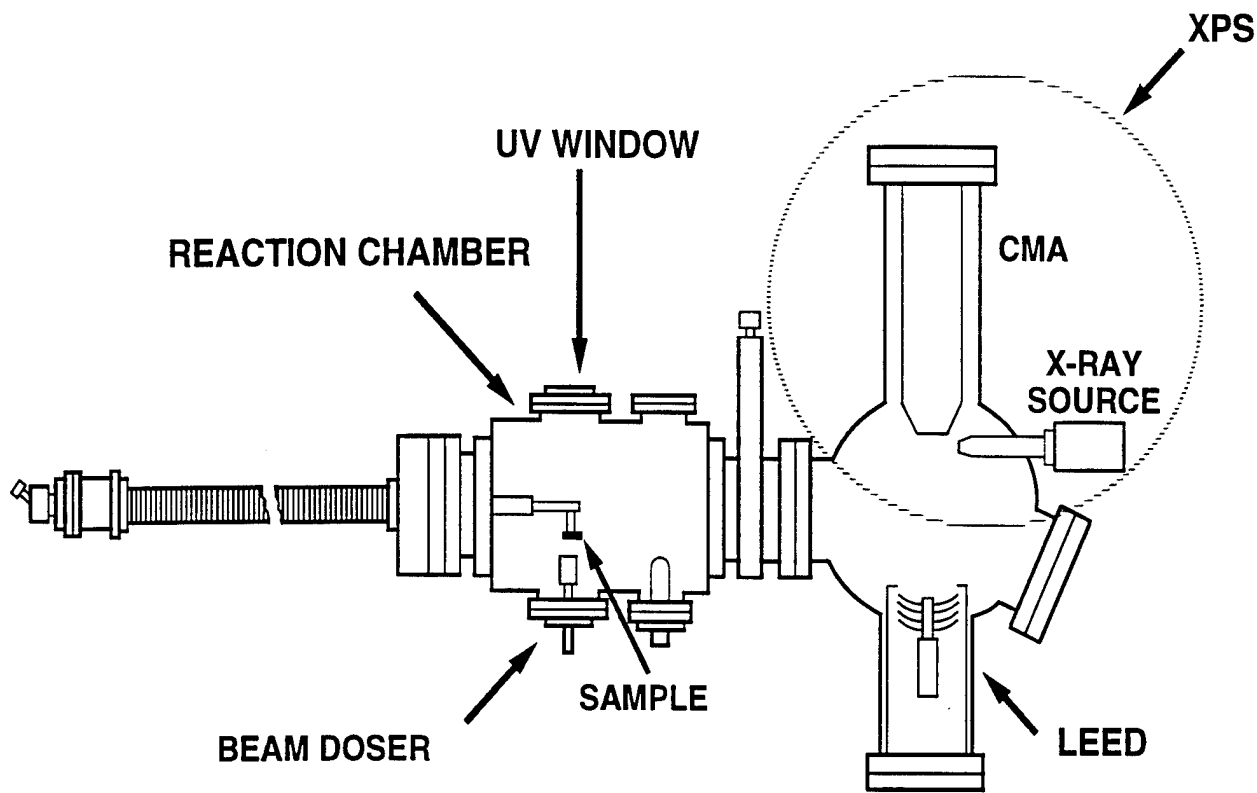

Figure 1 Schematic of ultrahigh vacuum chamber.

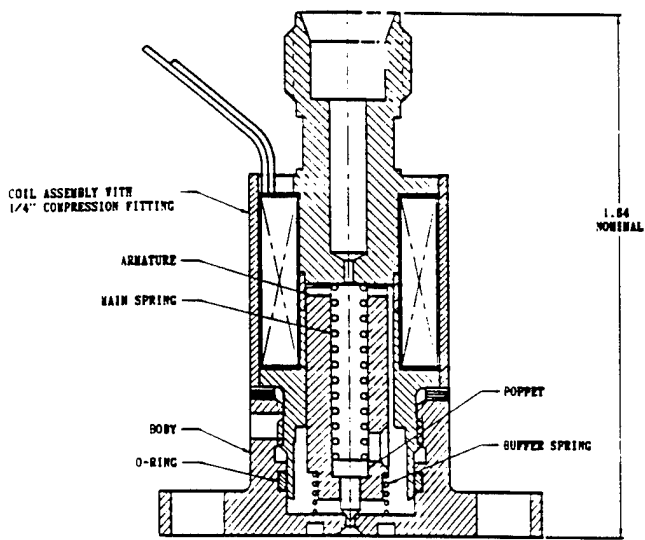
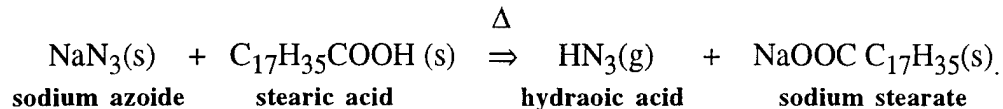

Figure 2. Schematic of pulsed molecular nozzle source

Hydrazoic acid, HN_3 , was synthesized according to the procedure described by Setzer.² HN_3 is made by the reaction of sodium azide with a slight excess of stearic acid:



The hydrazoic acid vapor can thus be collected, leaving behind the unwanted sodium stearate. Since the hydrazoic acid is highly combustible and explosive, great care needs to be taken in order to avoid a hazardous situation. We constructed a gas synthesis system comprising a thick-walled Pyrex vacuum tube to hold the precursor chemicals, Teflon stopcocks and stainless steel bellows valves, Teflon and stainless steel tubing and a stainless steel cylinder (500 cm³ volume) for collection of the hydrazoic acid. A 1000 Torr Baratron capacitance manometer was used to measure the pressure and a dry pump (Hovac) used to pump the system to below a millitorr background pressure. The precursor chemicals were put into the glass bulb and the system sealed off. The entire system was then heated to 50° C for two hours while being evacuated; any remaining water or atmospheric gases were removed by use of several flush and purge cycles using helium. When the glass bulb was heated to ~ 70 °C, the stearic acid melted as expected.³ Upon further heating to 100 °C, bubbling of the mixture was noticed, indicating production of hydrazoic acid. The vacuum pump was disconnected from the system and HN_3 was collected in the sample cylinder until a pressure of 25 Torr was reached. At this point, the temperature was lowered, shutting off further reaction. The sample cylinder was then backfilled with helium to a pressure of ~760 Torr, producing a 3% mixture of hydrazoic acid in helium. When preparing the mixtures with krypton, identical procedures were used. An atmospheric sampling mass spectrometer was used to analyze the mixture. The spectrum, reproduced below (Figure 3), indicates that besides HN_3 , the only identifiable species is oxygen.

The GaAs (110) substrates were mounted in the chamber, Ar^+ etched for 30 minutes at 1 keV to remove any traces of carbon or oxygen contamination, and annealed at 580 °C for 60 minutes. X-ray photoelectron spectroscopy (XPS) and low energy electron diffraction (LEED) patterns of the samples indicated that surface order had been restored and a gallium rich reconstruction ($\text{Ga}/\text{As} \approx 1.3$) had formed. The samples were then exposed to doses of hydrazoic acid that were determined by setting both the pulse length and number of pulses. XPS spectra were taken using PHI 15 keV Mg and Al $K\alpha$ X-ray sources and a PHI double-pass cylindrical mirror electron energy analyzer operated at 25 and 50 eV depending on the particular transition being studied. All spectra are referenced to the As 3d transition at 41.5 ± 0.2 eV.

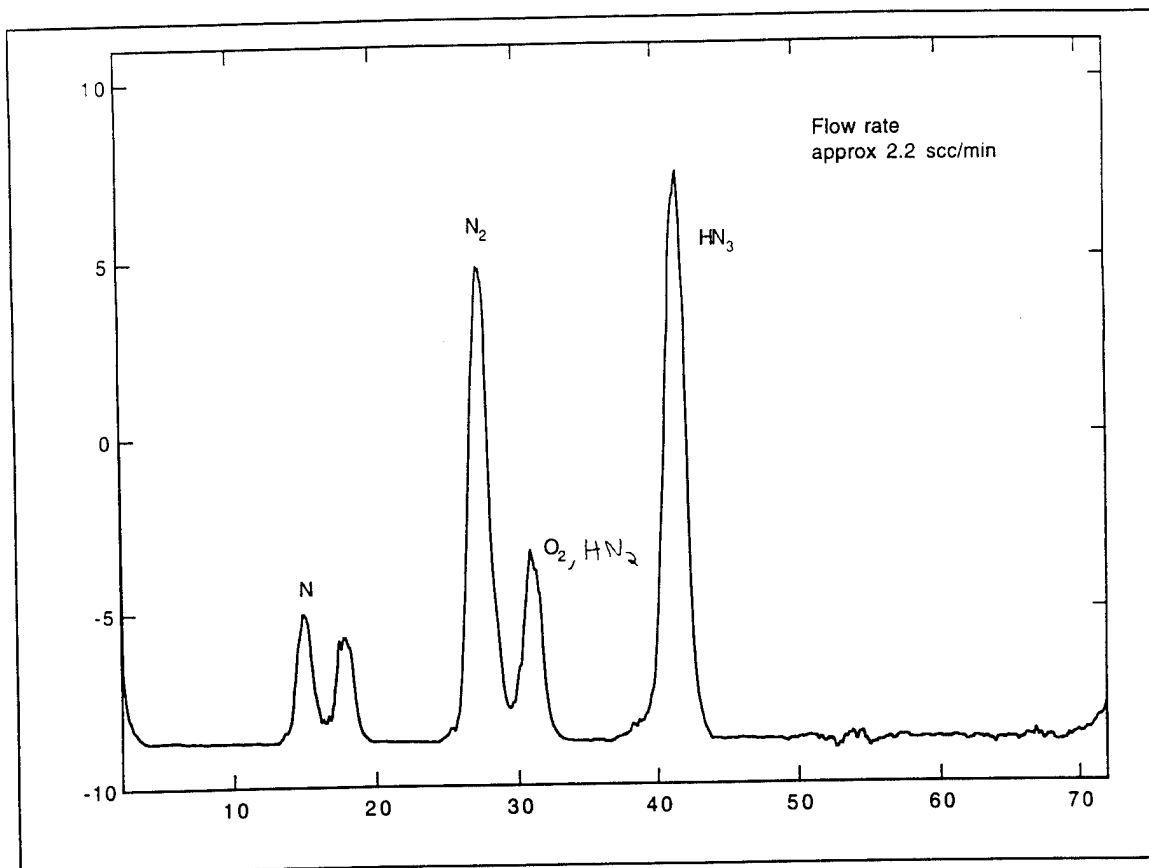

Figure 3 Mass Spectrum of Hydrazoic Acid Mixed in Helium Prepared as Described Above.

2.2 Results

The sensitivity of XPS to depth is related to the escape depth of the emitted electrons, which in turn is a function of their characteristic escape depths. The $2p_{3/2}$ transitions of Ga and As are quite surface sensitive. Probing the Ga transition using the Mg anode and the As transition using the Al anode produces electrons with kinetic energies on the order of 100 eV. Electrons with these kinetic energies have been shown to have characteristic $(1/e)$ escape depths of only 6-8 Å. Thus these transitions can be effectively used to interrogate the first few 5-10 layers of the GaAs surface (lattice parameter = 5.65 Å). The 3d transitions of Ga and As, on the other hand, involve small binding energies and electron kinetic energies of over 1000 eV and thus sample comparatively thick layers on the order of 50-100 Å. Coupling these two sets of transitions allowed us to readily determine the chemical composition of the growing film.^{4,5} In addition, we monitored the N and O 1s transition; the Ga LMM Auger transition (using the Mg anode) was also

recorded in order to provide a further information on the chemical composition of the growing film.⁶

Figures 4-6 present a series of XPS spectra showing the reactions of GaAs (110) with hydrazoic acid (seeded in krypton) as a function of substrate temperature during the dosing cycle. Each individual experiment shown involved exposure to doses sufficiently high to saturate any possible reaction path ($\sim 10^{18} \text{ cm}^{-2}$). (Experiments recorded using hydrazoic acid seeded in helium gave virtually identical results.) Figure 4 presents the N 1s spectra. At 310 K (slightly above room temperature), only one peak is observed which is indicative of the presence of NH and N₂ species adsorbed on the surface. This assignment has been made by and confirmed by groups led by Lin^{7,8} at Emory and White at Texas (Austin)^{9,10}. The absence of a peak above 400 eV indicates that there is no undissociated hydrazoic acid present on the surface at these temperatures. The Ga and As 2p_{3/2} spectra shown in Figures 5 and 6 show no indication of any nitride formation since the recorded spectra are identical with those recorded on clean GaAs surfaces. From the poor signal to noise ratios of the nitrogen spectra, we estimate that at 310 K, a monolayer of hydrazoic acid dissociatively chemisorbs to form dinitrogen and amido radicals on the surface. There is no evidence for any breakage of Ga-As bonds. Furthermore, most of these nitrogen adspecies desorb from the surface when it is heated to 473 K and within our ability to detect them, they are completely desorbed by 573 K.

At 473 K, a different situation obtains. The nitrogen spectrum shown in Figure 4 shows evidence of a slight shoulder to lower binding energies compared to the previous NH/N₂ peaks. This shoulder occurs precisely where one would expect to find a peak for GaN and AsN.⁷⁻¹⁰ Comparing the intensity of the shoulder to the main peak, we estimate that no more than a monolayer of GaN/AsN is formed. The Ga 2p peak shows a slight shift upward of $\sim 0.2\text{-}0.3 \text{ eV}$ and the As 2p peak shows slight evidence of a shoulder at higher binding energies; this data is consistent with the formation of both AsN and GaN. It should also be noted that the ratio of arsenic to gallium remains constant throughout the dosing process.

A radical transition in the observed chemistry takes place when the sample is dosed at 673 K. Note that the N 1s peak corresponding to NH/N₂ has disappeared and been totally replaced by a peak corresponding to GaN/AsN. Furthermore, the integrated intensity of this peak is several times greater than that of the nitrogen peak found at 310 K and is thus indicative of a nitride film that is several layers thick. The Ga 2p spectrum has also shifted 0.5 eV to higher

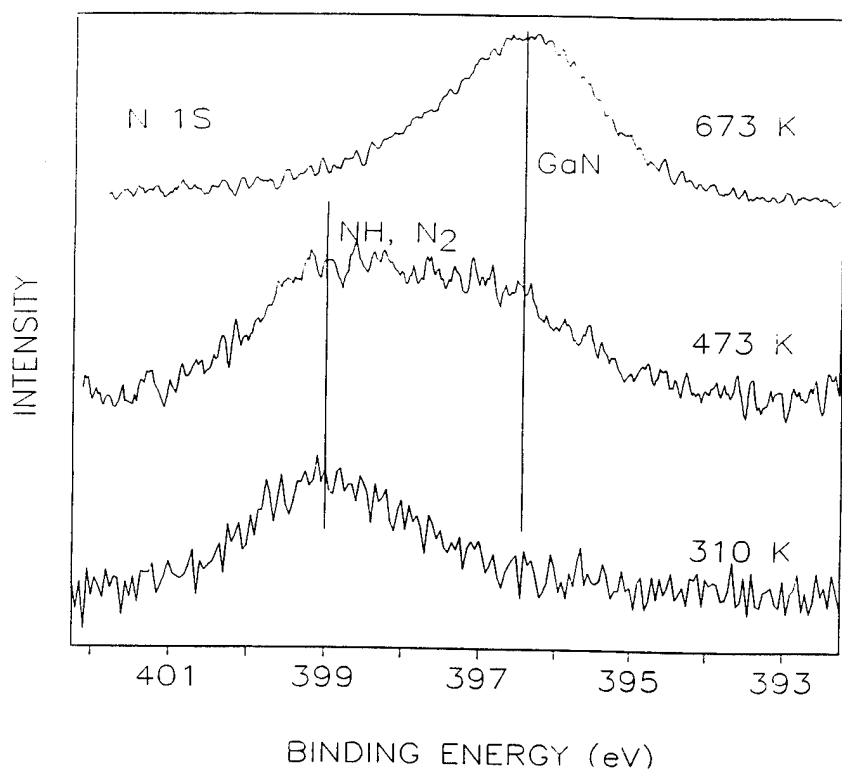

Figure 4. N 1s transition XPS spectra of GaAs(110) substrates after having been dosed to saturation with hydroic acid as a function of substrate temperature.

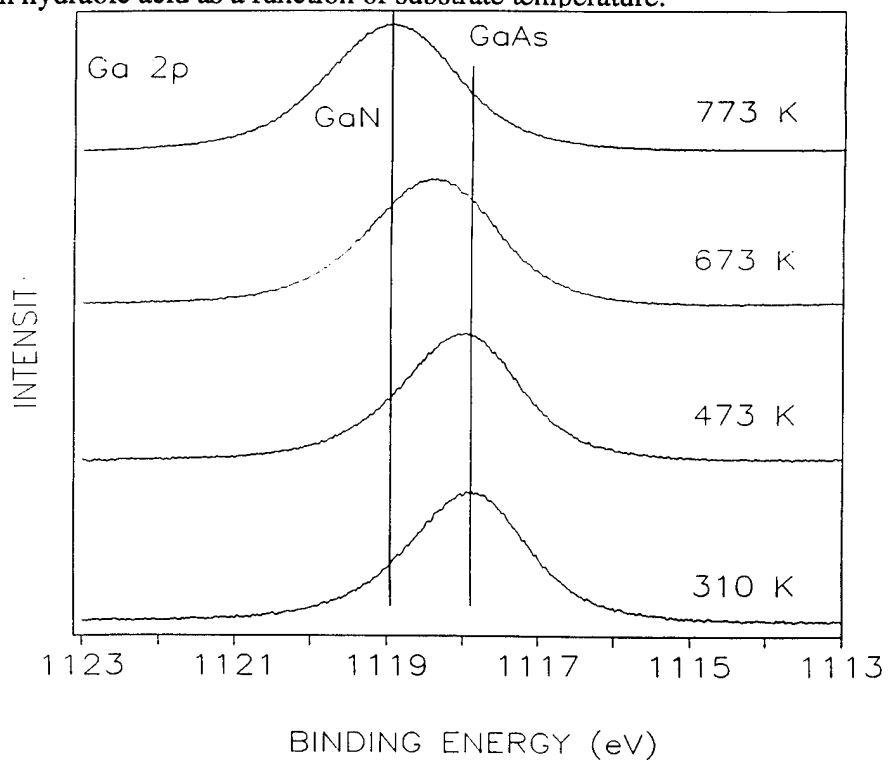

Figure 5. Ga 2p_{3/2} transition XPS spectra of GaAs(110) substrates after having been dosed to saturation with hydroic acid as a function of substrate temperature.

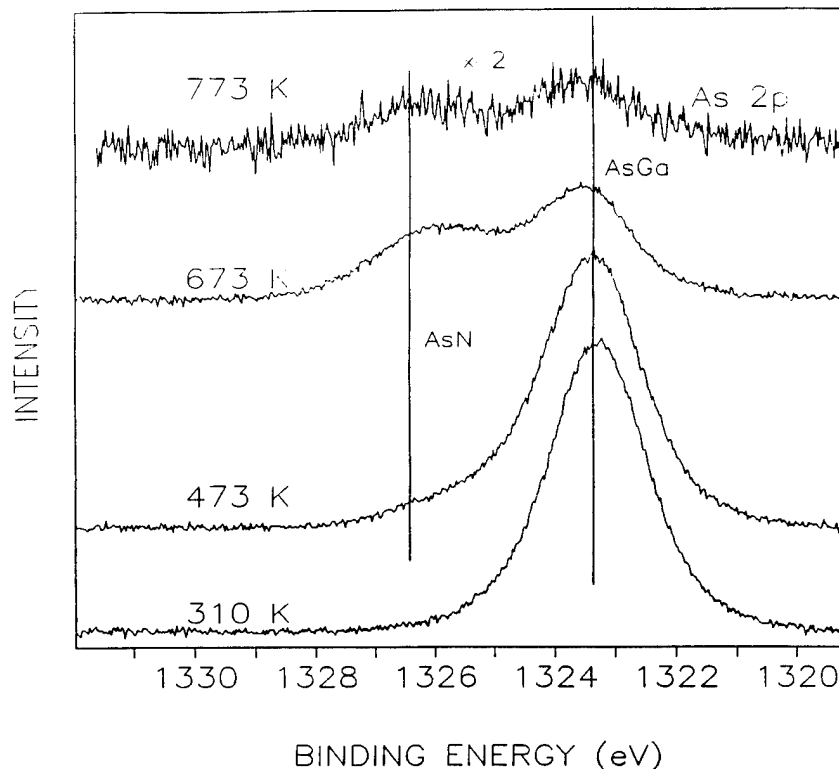
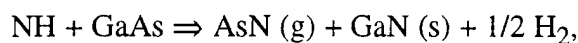

Figure 6. As $2p_{3/2}$ transition XPS spectra of GaAs(110) substrates after having been dosed to saturation with hydroic acid as a function of substrate temperature.

binding energy from clean GaAs indicating the formation of several layers of GaN. The As 2p spectrum shows two distinct peaks; one at that found for bulk GaAs and one which corresponds to AsN which is at ~ 2.3 eV higher binding energy. But even more illuminating is the loss of integrated intensity of the As peak and growth in the Ga peak intensity. The Ga intensity has increased by 50% while the As intensity has fallen by over half. This trend is indicative of an anionic exchange mechanism where the NH radical reacts with the arsenic to form volatile AsN:



leaving behind the thermally more stable gallium nitride. This same behavior is observed in the reactions of GaAs with fluorine atoms and molecules to form GaF_3 thin films, albeit at lower temperatures.^{5,11,12} The observation of some AsN residue is the result of the fact that the GaN layer, at sufficient thickness, acts as a diffusion barrier to the volatilization of the AsN species.

As deposition takes place at higher temperatures, one expects the film to grow thicker before the reaction product layer acts as a diffusion barrier. We observe precisely this behavior! The integrated intensity of the nitrogen spectrum of GaAs dosed at 773 K (not shown) is several times that found at 673 K. Furthermore, the Ga 2p peak has completely shifted to higher binding energies consistent with the formation of a GaN thin film which is on the order of three times the escape depth of this transition or 20-25 Å. The arsenic peak has almost completely disappeared

indicating that it has been completely replaced in this reaction product region. Note that there is still a trace of some AsN which must reside at the interface of the GaN and GaAs. Scanning Auger spectroscopy performed at NCSU confirmed the formation of a comparatively thick GaN thin film.

We note that the HN_3 sample is contaminated with a small amount of oxygen. GaAs is highly reactive to small amounts of oxygen and the XPS spectra obtained in these experiments show oxygen concentrations on the surface which are comparable to that found for nitrogen. Thus, we are forming oxynitride films. To investigate whether any of the above spectra were due to the presence of oxygen in the beam, we repeated all the experiments with a pure oxygen beam. We did not observe any of the behavior associated with the HN_3 experiments. We saw almost none of the anionic exchange mechanism prevalent for HN_3 and some formation of a gallium oxide species. Figure 7 shows the Ga LMM Auger transition for pure GaAs, GaAs exposed to a beam of oxygen and GaAs exposed to the HN_3 beam contaminated with oxygen at surface temperatures of 773 K. Note that the GaAs/ O_2 spectrum is virtually identical to that found on the clean surface. On the other hand, the GaAs/ HN_3 spectrum is quite different. A new peak, indicative of GaN, is formed at a binding energy of ~ 190.5 eV. Thus, we believe that the presence of oxygen had little effect except to prevent the formation of epitaxial films upon further heating to 850 K.

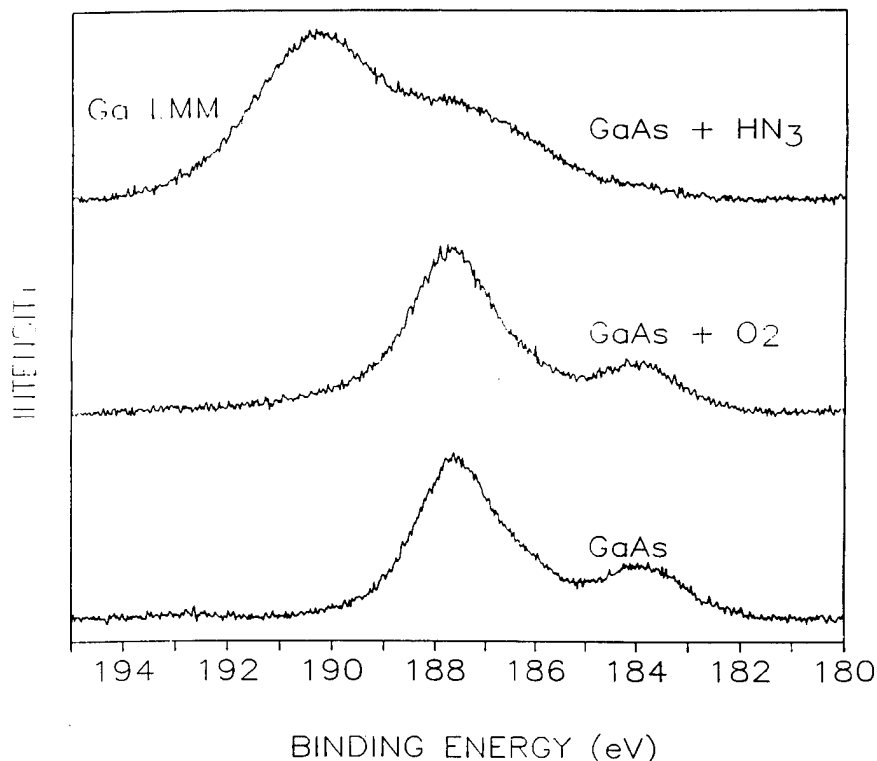

Figure 7. Spectra of Ga LMM Auger transitions of a clean GaAs (110) substrate and substrates at a temperature of 773 K exposed to O_2 and HN_3 beams respectively.

Figure 8 summarizes the data by presenting a graph showing the thickness of the GaN film formed by dosing with hydrozoic acid as a function of substrate temperature. At 310 K, no GaN film is formed; HN_3 dissociatively chemisorbs but does not break any GaAs bonds. At 473 K, a monolayer of GaN/AsN is formed before the reaction stops. At 673 K, a GaN layer $\sim 6 \text{ \AA}$ thick forms with an AsN layer found at the GaN/GaAs interface. At 773 K, the GaN layer can be grown to a thickness of 20 \AA before the anionic exchange mechanism is cut off by the inability of the AsN to diffuse to the surface. We estimate that the thickness of the GaN/GaAs interface region which contains undesorbed AsN) to be $\sim 5 \text{ \AA}$.

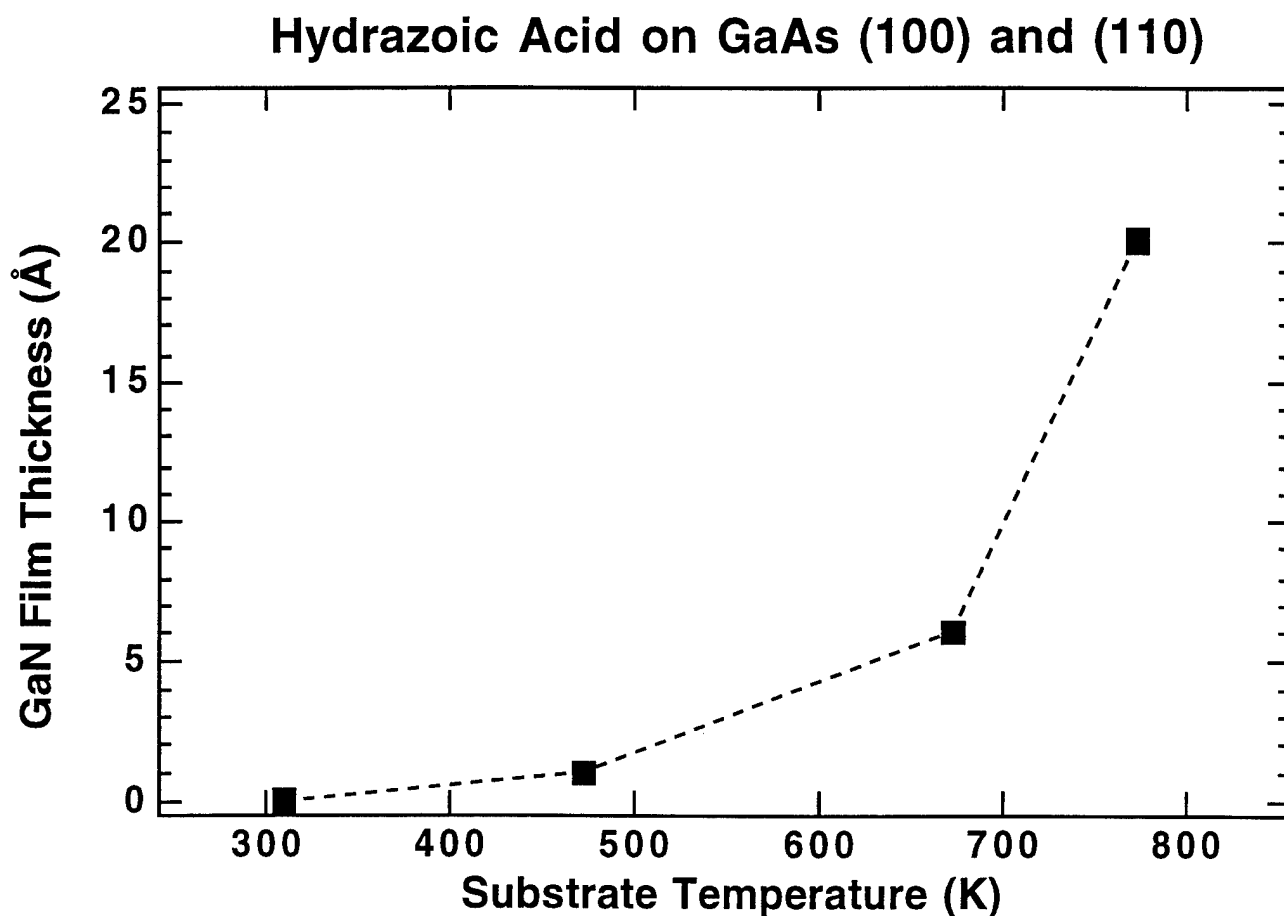

Figure 8. GaN film thickness as a function of substrate temperature

2.3 Conclusions

Gallium arsenide surfaces were found to be surprisingly reactive towards hydrazoic acid. Lin and co-workers^{7,8} had shown that when gallium arsenide was dosed with hydrazoic acid at low temperatures, the HN_3 desorbed from the surface below 200 K with no trace of any reaction. Apparently, at room temperature and above, the surface becomes reactive and HN_3 dissociatively chemisorbs upon adsorption. Due to this reactivity, no kinetic energy effect is observed. One would only expect to observe such a dependence if there were an activation barrier to reaction. But at 310 K, this reaction pathway does not involve the breaking of any Ga-As bonds and saturates at a monolayer coverage of NH and N_2 species.

As the substrate temperature is increased to 473 K, Ga-As bonds are broken and GaN and AsN species are formed. But even at this temperature, the reaction is limited to the topmost layer. At 673, on the other hand, a preferential etching process leading to anionic exchange occurs. Subsurface arsenic is removed by the formation and desorption of volatile AsN, leaving behind GaN. This behavior is similar to that found for the fluorination reactions of GaAs which lead to the formation of GaF_3 thin films.^{5,11,12} The thickness of the thin film that can be formed in this fashion is extremely temperature sensitive. At 673 K, the thin film is limited to 5-6 Å; at 773 K, a 20 Å GaN film can be formed. This temperature effect is caused by the fact that the forming GaN film acts as a diffusion barrier to the inward path of the active nitrogen species and to the desorption of subsurface AsN. As a result, there is always an interface layer between the GaAs substrate and GaN film containing some AsN species (see Figure 9).

This observed reactivity of hydrazoic acid at relatively low temperatures indicates that HN_3 is an excellent source of neutral forms of 'active nitrogen' which does not require any sort of discharge or excitation. Recent work of John Russell at the Naval Research Laboratory has indicated that HN_3 will also readily react with crystalline aluminum surfaces to form epitaxial layers of AlN as well.¹³ Thus it would seem that if a low temperature form of metallic gallium or aluminum is provided at the surface, binary or ternary metal nitride films could be readily grown on arbitrary surfaces at reduced temperatures. Organometallic species, such as diethyl gallium and aluminum, are excellent choices of metal atom precursors. They decompose at temperatures well below that required for metal nitride growth (< 750 K). It would seem that film growth could readily be accomplished using heated pulsed nozzles of both metal and nitrogen precursor molecules such as diethylgallium and hydrazoic acid. We note that Lin and co-workers have grown epitaxial α -GaN films on sapphire using a low pressure chemical vapor deposition system using hydrazoic acid and triethylgallium at 850 K.¹⁴

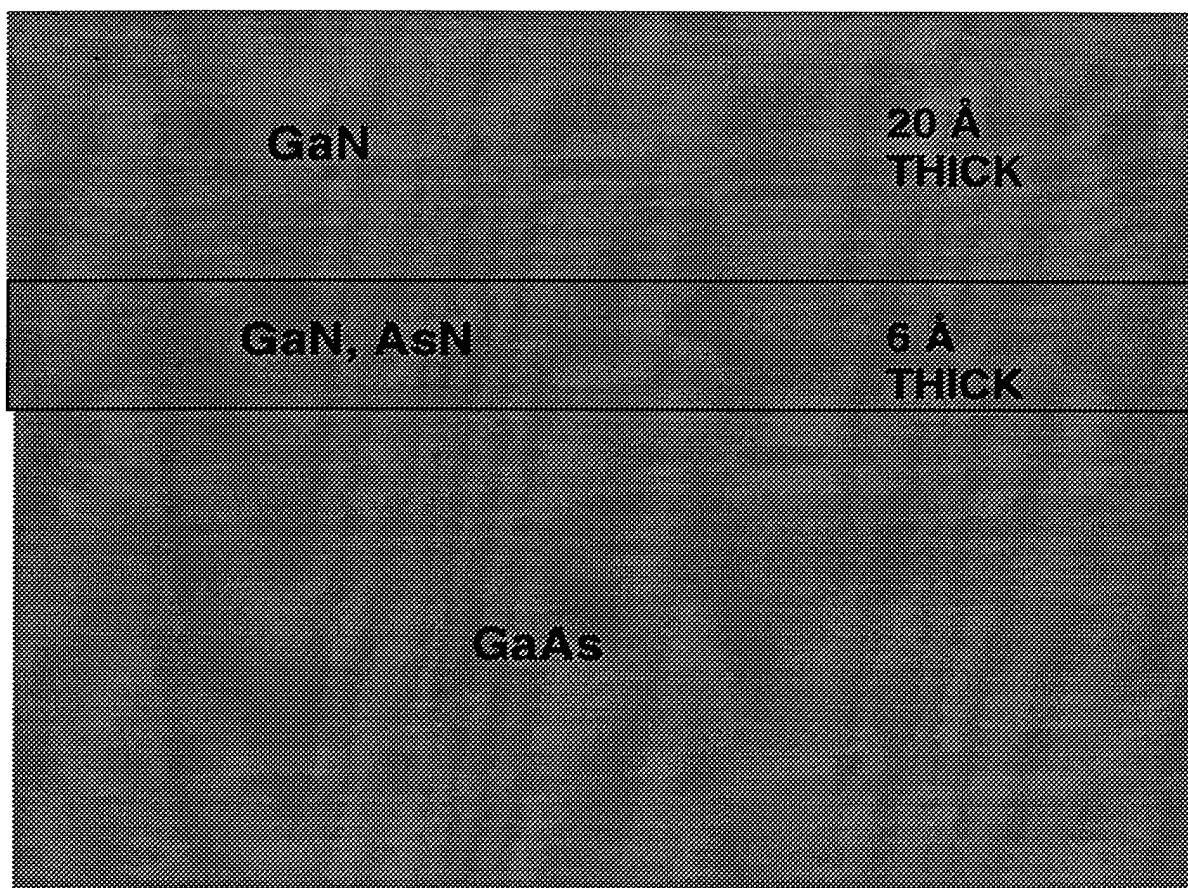

Figure 9. Schematic diagram of the GaN thin formed as a result of the dosing of a GaAs (110) with HN_3 at a substrate temperature of 773 K. The total dose of HN_3 was $\sim 5 \times 10^{18} \text{ cm}^{-2}$.

2.4 References

1. D.L. Flamm in *Plasma Etching*; D.M. Manos, D.L. Flamm Eds; Academic Press; San Diego, 1989; Chapter 2
2. J. Haabadas, S. Wategaonkar, and D.W. Setser, *J. Phys. Chem.* 91, 451 (1987)
3. *Handbook of Chemistry and Physics*, 72 Edition; CRC Press; Boca Raton, 1997; edited by D.R. Lide
4. L.A. Deluise, *J. Appl. Phys.* 70, 1718 (1995); *J. Chem. Phys.* 94, 1528 (1991)
5. A. Freedman and C.D. Stinespring, *J. Phys. Chem.* 96, 2253 (1992)

6. J.F. Moulder, W.F. Stickle, P.E. Sobol, and K.D. Bomben, Handbook of X-Ray Photoelectron Spectroscopy, PHI Corporation, Eden Prairie, MN (1994)
7. Y. Bu and M.C. Lin, Surf. Sci. 317, 152 (1994)
8. Y. Bu, J.C.S. Chu, and M.C. Lin, Surf. Sci. Lett. 264, L154 (1992_
9. X.Y. Zhu, M. Wolf, T. Huett and J.M White, J. Chem. Phys. 97, 5856 (1992)
10. Y.M.Sun, D.W. Sloan, M. McEllistrem, A.L. Schwaner and J.M .White, J. Vac. Sci. Technol. A13, 1455 (1995)
11. A.S. Barrière, G. Couturier, H. Guégan, T. Séguelond, A. Thabti, P. Alnot and J. Chazelas, Appl. Surf. Sci. 41/42, 383 (1990)
12. A.S. Barrière, B. Desbat, H. Guégan, L. Lozano, T. Séguelond, A. Tressaud and P. Alnot, Thin Solid Films, 170, 259 (1989)
13. John Russell, Naval Research Laboratory, personal communication
14. Y. Y. Bu, M.C. Lin, L.P.Fu, D.G. Chetchekine, G.D., Y. Chen, S.E. Ralph, and S.R. Stock, Appl. Phys. Lett. 66, 2433 (1995)

3. DEPOSITION OF GaN FILMS USING SEEDED SUPERSONIC BEAMS

3.1 Introduction

The potential optoelectronic applications of wide bandgap materials have stimulated considerable research concerned with thin film growth, characterization and device development of the III-V nitrides, namely cubic BN, AlN, GaN and InN. Of this family GaN has been the most thoroughly studied. An indication of the potential of GaN is revealed in the materials high Johnson's and Keye's figures of merit of 80.0×10^{11} and 4.2×10^8 , respectively, compared to 4.75×10^{11} and 2.39×10^8 for silicon¹. Gallium nitride usually forms in the wurtzite structure with a bandgap of 3.4 eV², although several groups³⁻⁶ have deposited films of the cubic (zinc blend structure) β -GaN which has a smaller bandgap of 3.26 eV. Wurtzitic GaN also forms continuous solid solutions with both AlN and InN which have bandgaps of 6.2 eV⁷ and 1.9 eV⁸, respectively. This characteristic permits the development of materials having engineered bandgaps for the construction of optoelectronic devices that are active from the visible to the deep ultraviolet frequencies.

A major difficulty in the growth of thin films of GaN is the lack of suitable substrates. The lattice parameters and coefficients of thermal expansion are given in Table 1 for GaN and the most common substrate materials of Si, SiC (6H and 3C), sapphire, ZnO and GaAs. With the possible exception of the basal planes of α (6H)-SiC and ZnO, none of these materials are suitable for the two-dimensional epitaxial growth of GaN.

To reduce thermal budgets and permit finer scale architecture, low GaN deposition temperatures are highly desirable. However, as deposition temperature is reduced, the surface mobility of deposition precursors is curtailed and film crystallinity and morphology are compromised. In addition to decreased surface mobility, another difficulty with low temperature GaN deposition is that the source materials, TEG and NH₃, decompose at greatly different temperatures. As the NH₃ molecule is more stable than the triethylgallium molecule, a mechanism to enhance the reactivity of ammonia is desirable.

Table 1. Physical properties of GaN and Potential Substrate Materials³.

Material	Lattice Parameter	Coefficient of Thermal Expansion
GaN	a = 3.189 Å	$5.59 \times 10^{-6} \text{ K}^{-1}$
	c = 5.185 Å	$3.17 \times 10^{-6} \text{ K}^{-1}$
Si	a = 5.43 Å	$3.59 \times 10^{-6} \text{ K}^{-1}$
α -SiC (6H)	a = 3.08 Å	$4.2 \times 10^{-6} \text{ K}^{-1}$
	c = 15.12 Å	$4.7 \times 10^{-6} \text{ K}^{-1}$
β -SiC (3C)	a = 4.36 Å	$2.7 \times 10^{-6} \text{ K}^{-1}$
Al ₂ O ₃	a = 4.758 Å	$7.5 \times 10^{-6} \text{ K}^{-1}$
	c = 12.991 Å	$8.5 \times 10^{-6} \text{ K}^{-1}$
GaAs	a = 5.653 Å	$6.0 \times 10^{-6} \text{ K}^{-1}$

Seeded supersonic beams may potentially drive the reaction and dissociative chemisorption of NH₃ on select substrates. By increasing the kinetic energy of the seeded molecules, a substantial amount energy can be carried by each molecule that can drive surface reactions when the molecule strikes the substrate surface. Engstrom et al.¹⁰ have determined that the reaction probability of Si₂H₆ on the Si(100) increases rapidly for incident supersonic beam energies above about 23 kcal mol⁻¹. If this effect can be applied to the reaction of NH₃ on selected substrate materials, film deposition may be accomplished at lower temperatures.

The objective of this research is to develop techniques for depositing GaN films using seeded supersonic jets. The immediate goal is to produce GaN films at reduced temperatures and determine the effect of varying deposition conditions on film character. Toward this end, GaN films deposited in an existing single jet system are being studied to determine ranges of growth parameters for GaN film deposition that can be used in a dual beam system now under construction.

3.2 Experimental Procedure

Sample cleaning: Si(100) and Si(111) substrates were cleaned in a three step process: First the substrates were immersed in a 10% HF solution for 1 minute to remove the native oxide. Next, the samples were exposed in air to ultra violet light to oxidize the surface. After the illumination, the substrates were again immersed in the 10% HF solution prior to loading into the reactor. Al₂O₃(0001) substrates were cleaned via a multiple step process. Firstly, the samples were successively ultrasonically cleaned in trichloroethylene, acetone and methanol. After d.i. water rinsing, the samples were immersed in a 70°C, 50:50 mixture of H₃PO₄ and H₂SO₄ for 5 minutes. After d.i. water rinsing, the substrates were finally immersed in a 10% HF solution and blown dry with N₂ immediately prior to installation in the reactor.

Deposition reactor: A schematic of the single beam deposition system is presented in Figure 1. This system may be operated in either of two modes depending on whether a skimmer is installed. All work up to this point has been conducted in the free jet mode where a skimmer is not installed.

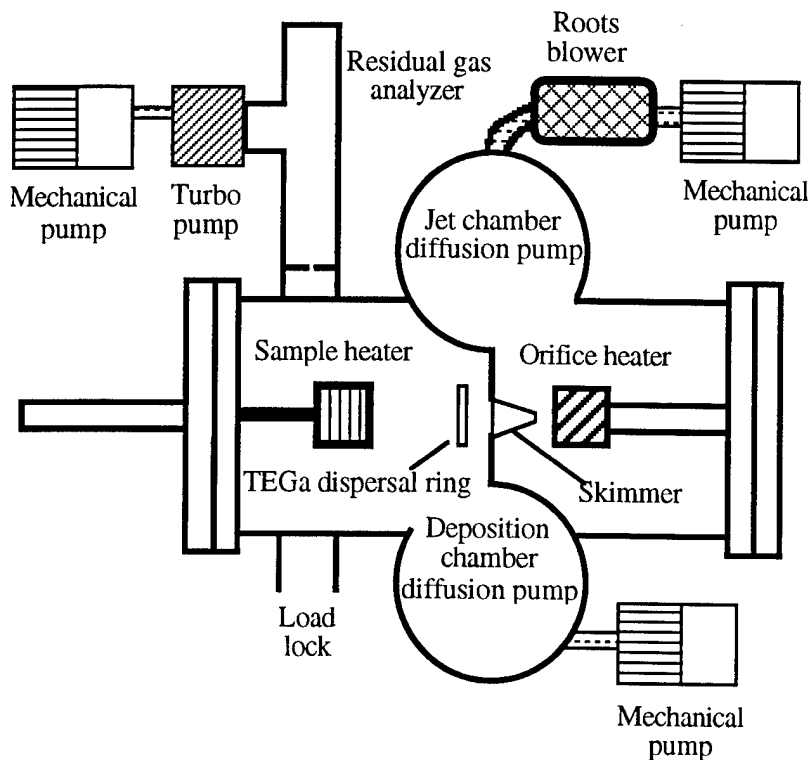

Figure 1. Single beam supersonic jet deposition system.

Deposition: After installation in the reactor, the samples are heated to the deposition temperature while a 5% NH₃ in He gas flow is maintained through the reactor. Typical deposition conditions are listed in Table 2. As indicated in the table, although the total flow rates may vary, an NH₃ to TEG ratio of ≈ 200 has been found to produce the best films. After deposition, the TEGa flow is terminated and the sample is cooled to $<200^{\circ}\text{C}$ under flowing NH₃/He.

Auger Electron Spectroscopy: Auger characterization was performed with a Perkin Elmer Auger spectroscopy system operated at 3 kV.

Scanning Electron Microscopy: Scanning electron microscopy, (SEM), was performed on a JEOL 6400 SEM with a field emission electron source operated at an accelerating voltage of 5 kV while sampling secondary electrons.

X-ray diffraction: The X-ray diffraction data were collected from a Rigaku X-ray diffractometer using CuK α radiation.

Table 2. Typical GaN deposition conditions.

Parameter	Value
Substrate temperature	540°to 650°C
Orifice pressure	600 to 1000 Torr
Orifice temperature	510°C
Orifice gas	5% NH ₃ in He
TEG bubbler temperature	-5 to 10°C
TEG bubbler pressure	280-800 Torr
TEG carrier	5 to 40 sccm He
NH ₃ / TEG ratio	≈ 200

3.3 Results and Discussion

Film Deposition

Stoichiometric GaN films can be produced across the range of process variables listed in Table 2. A scanning electron micrograph of a GaN film deposited on a Si(111) substrate is presented in Figure 2. This film was deposited at 560°C and exhibited excellent thickness uniformity and minimal surface roughness. Figure 3 is a scanning electron micrograph of a GaN film deposited on an $\text{Al}_2\text{O}_3(0001)$ substrate under conditions identical to those for the film in Figure 2. This latter film was not of uniform thickness and has a much more irregular surface.

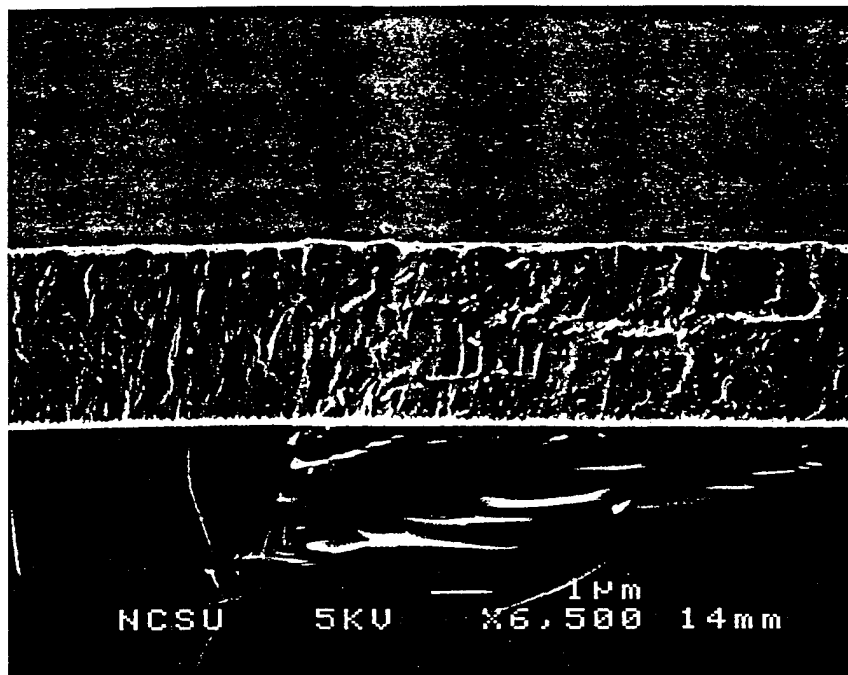

Figure 2. Scanning Electron Micrograph of GaN film deposited on Si(111) substrate.

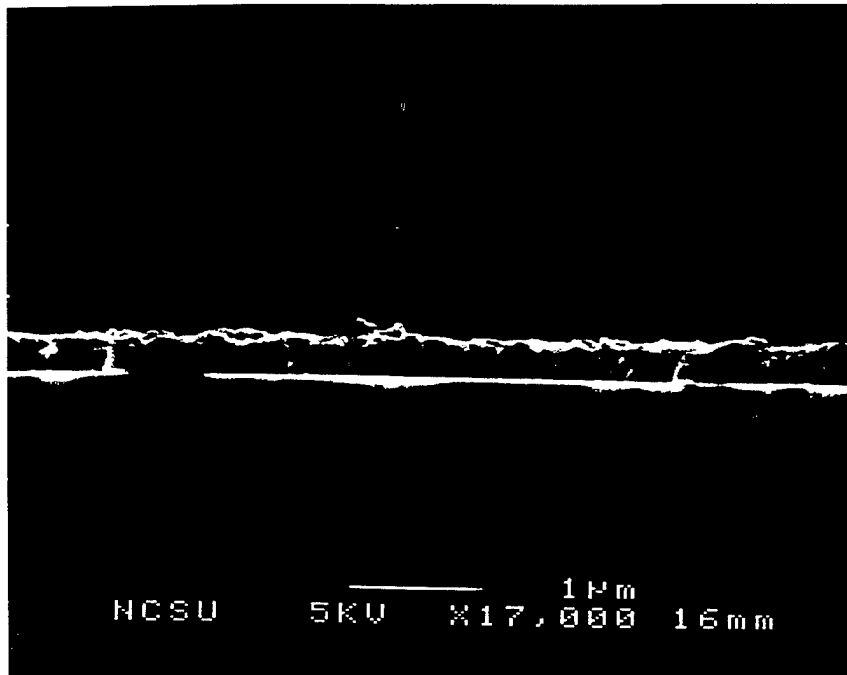

Figure 3. SEM of a GaN film deposited on $\text{Al}_2\text{O}_3(0001)$ substrate.

Auger electron spectroscopy revealed that C and O are the major contaminants in the deposited GaN films. Figure 4 compares three spectra taken from a GaN film before sputtering, after Ar ion sputtering for 60 seconds and finally after sputtering for 120 seconds total. A reduction in the C and O content after the initial 60 second sputter is indicated in the figure. This is consistent with the removal of a surface contamination layer. The supersonic beam deposition chamber is not connected to the Auger analysis chamber, precluding in-vacuo transfers and necessitating an in-air transfer that exposes the samples to contaminants.

Auger of GaN Deposited With Free Jet

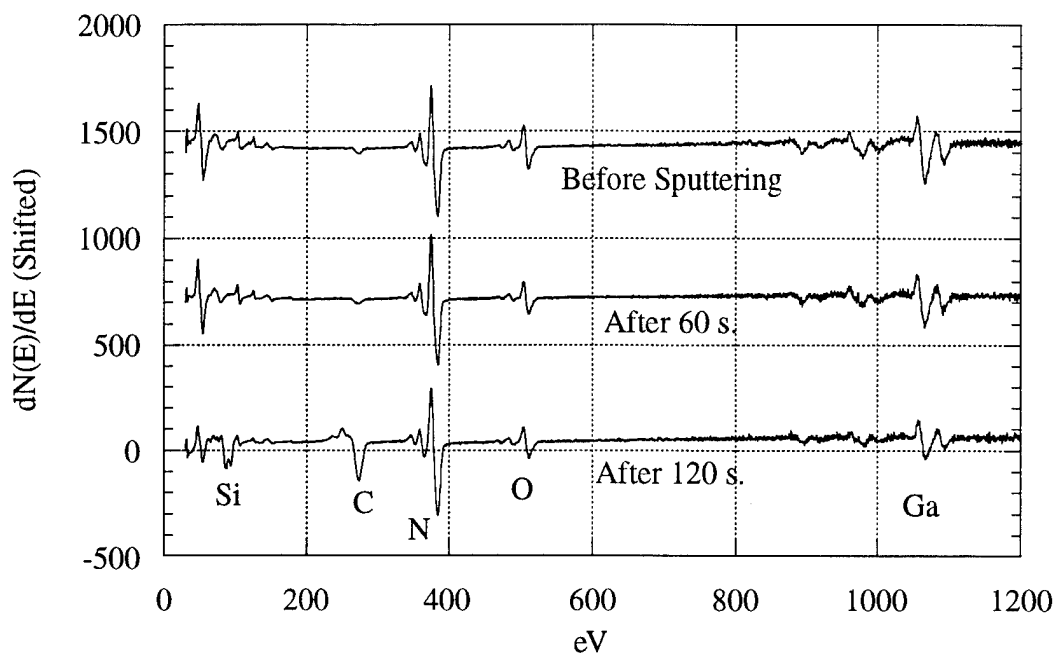

Figure 4. Auger electron spectra collected from GaN film before and after Ar ion sputtering.

The spectrum collected after 120 seconds of Ar ion sputtering shows significant C contamination. This last spectrum also shows the presence of Si, indicating that most of the GaN film had been milled away revealing the Si substrate. The fine structure of the C peak is consistent with graphitic C and not SiC. The presence of the C at the film/substrate interface is attributed to C contamination in the deposition system. The chamber is pumped by oil diffusion pumps and oil contamination is always a concern.

In order to elucidate the effect of nozzle temperature on GaN film character, a series three GaN films were deposited on Al_2O_3 substrates under the conditions listed in Table 3. All of these films were deposited under identical conditions, except for the different nozzle temperatures as indicated in the table. Scanning electron micrographs of the three separate samples, presented in Figures 5-7, demonstrate the marked effect of nozzle temperature on the resultant film morphology.

The film in Figure 5 was deposited with a $90^\circ C$ nozzle and exhibits an irregular, pebbly surface. The GaN film deposited with a nozzle temperature of $400^\circ C$, pictured in Figure 6, has a more regular structure and begins to reveal indications of preferred orienting. Finally, the GaN

film deposited with a 510°C nozzle, shown in Figure 7, demonstrates a well developed columnar structure. The epitaxial relationship between the film and the Al₂O₃(0001) substrate is evidenced by the absence of multiple peaks in the X-ray diffraction pattern in Figure 8. The RHEED pattern in Figure 9 further indicates the preferred in-plane rotational orientation of the columnar structures. This series demonstrates an increase in the degree of preferred orientation of GaN films deposited at increasing NH₃ nozzle temperatures.

Table 3. Deposition conditions employed to study the effect of nozzle temperature on deposited GaN film properties.

Parameter	Run 1	Run 2	Run 3
Substrate temperature	650°C	650°C	650°C
Orifice pressure	1000 Torr	1000 Torr	1000 Torr
Orifice temperature	90°C	400°C	510°C
Orifice gas	5% NH ₃ in He	5% NH ₃ in He	5% NH ₃ in He
TEG bubbler temperature	5°C	5°C	5°C
TEG bubbler pressure	280 Torr	280 Torr	280 Torr
TEG carrier	14 sccm He	14 sccm He	14 sccm He
NH ₃ / TEG ratio	≈200	≈200	≈200

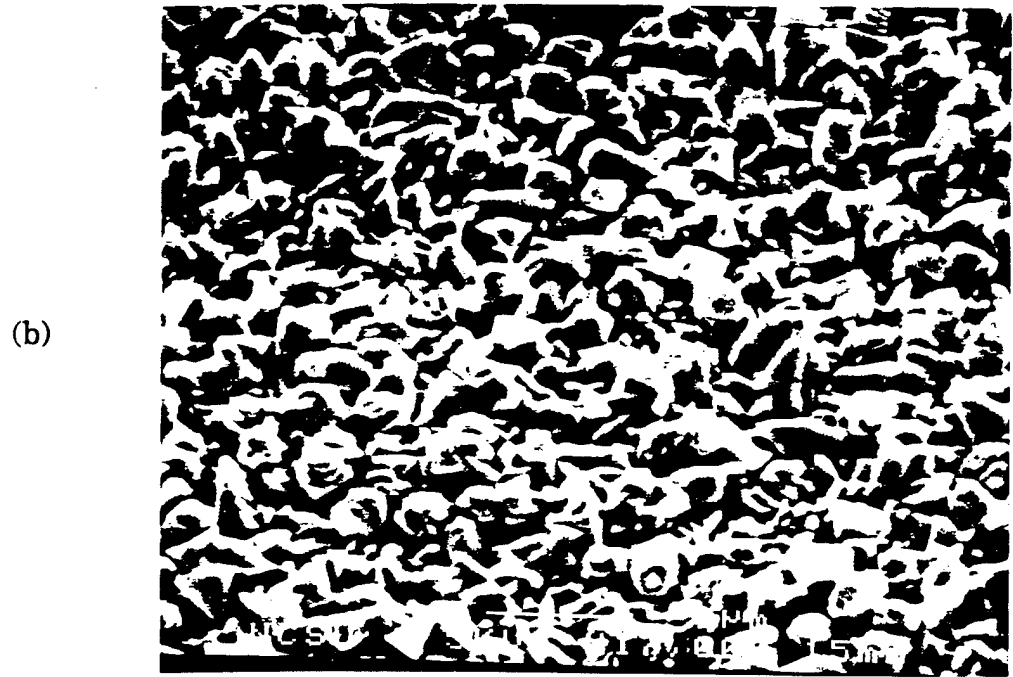
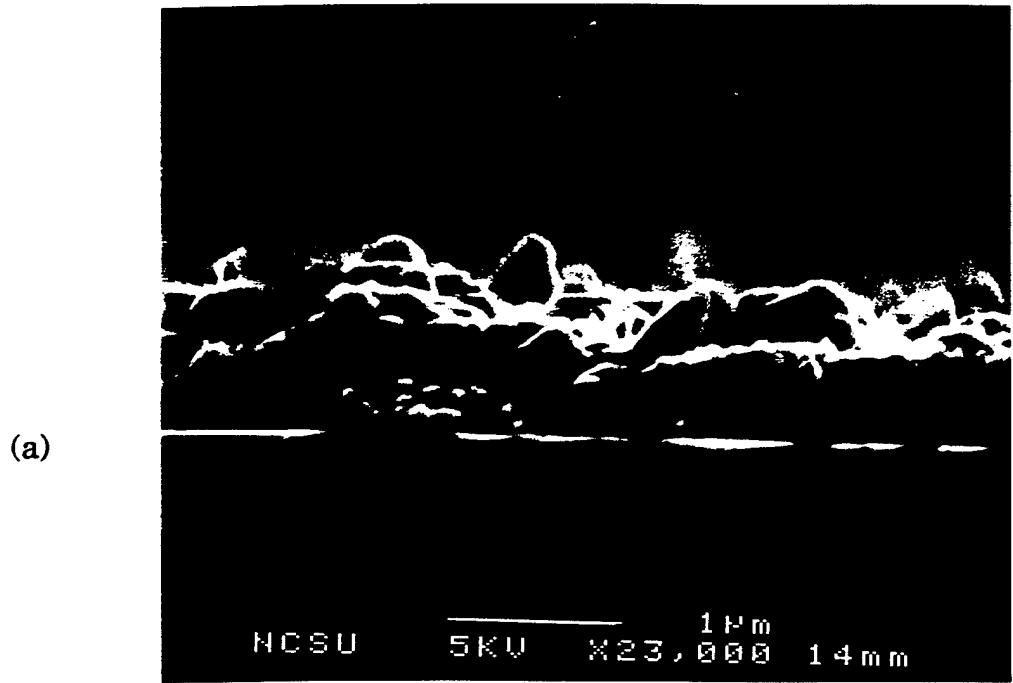

SEM-GaN film deposited on Al₂O₃ at 650°C substrate temperature and 90°C NH₃ nozzle temperature: (a) cross-section (b) top view.

Figure 5.

(a)

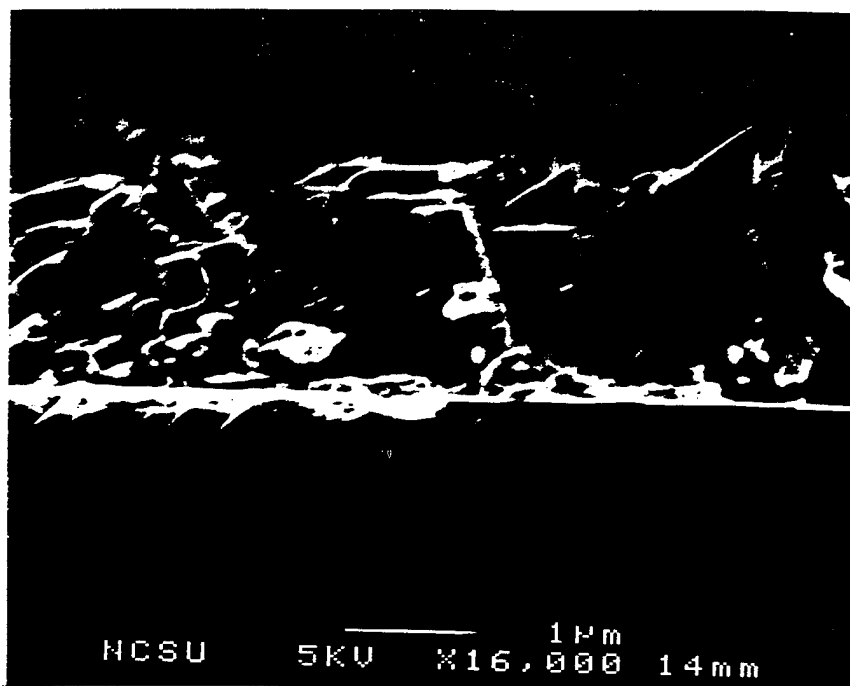

(b)

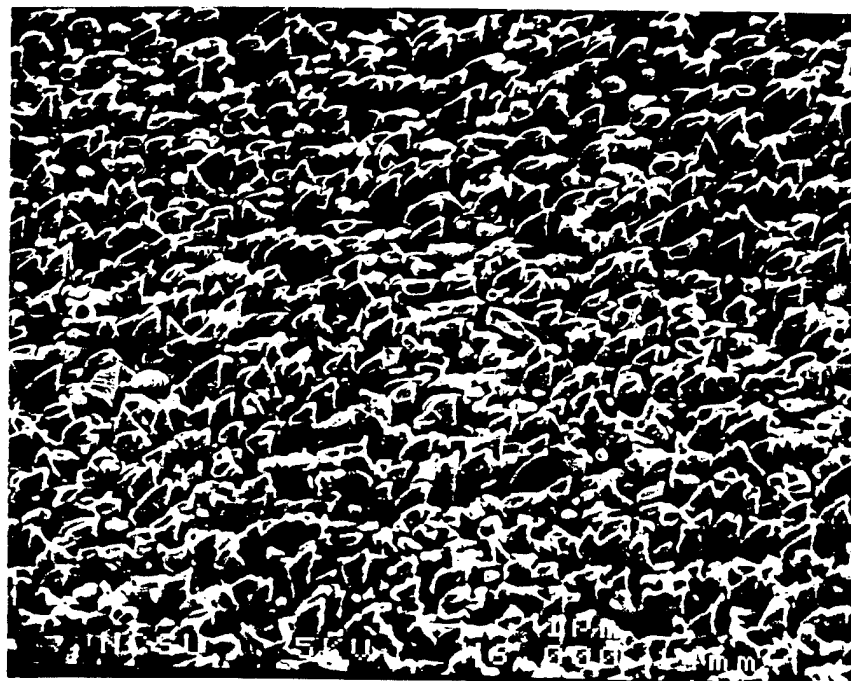

SEM-GaN film deposited on Al₂O₃ at 650°C substrate temperature and 400°C NH₃ nozzle temperature: (a) cross-section (b) top view.

Figure 6.

(a)

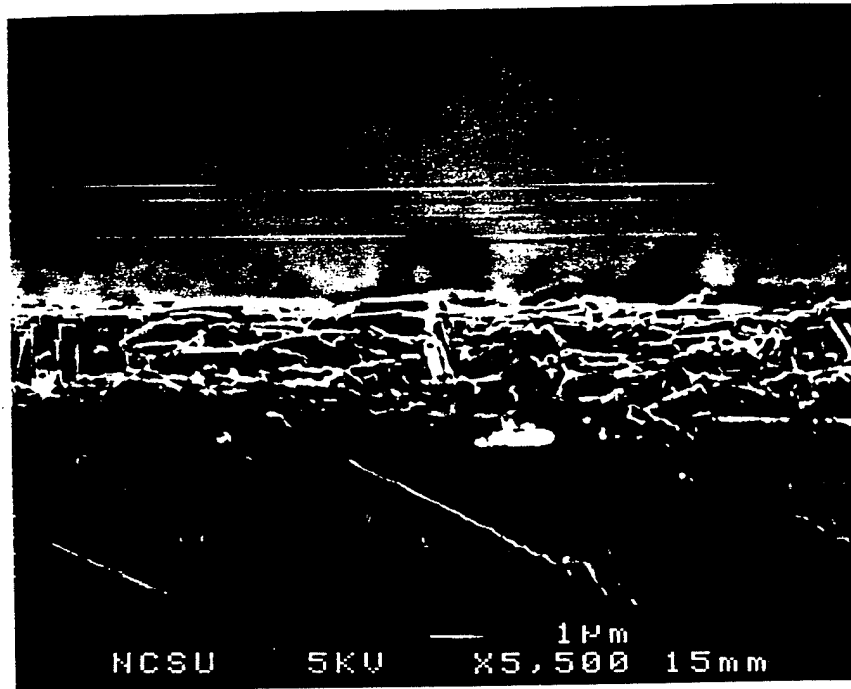

(b)

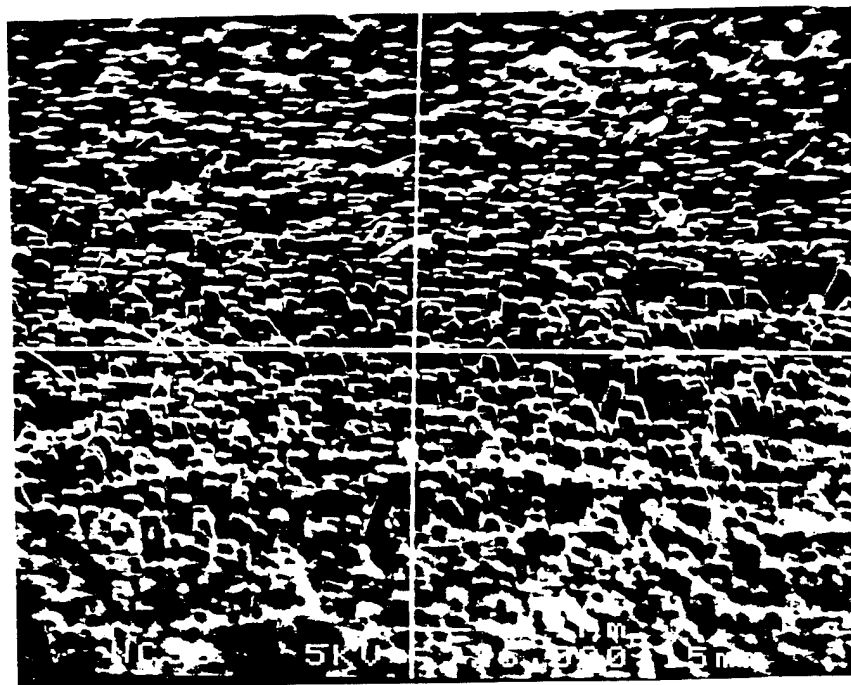

SEM-GaN film deposited on Al₂O₃ at 650°C substrate temperature and 510°C NH₃ nozzle temperature: (a) cross-section (b) top view.

Figure 7.

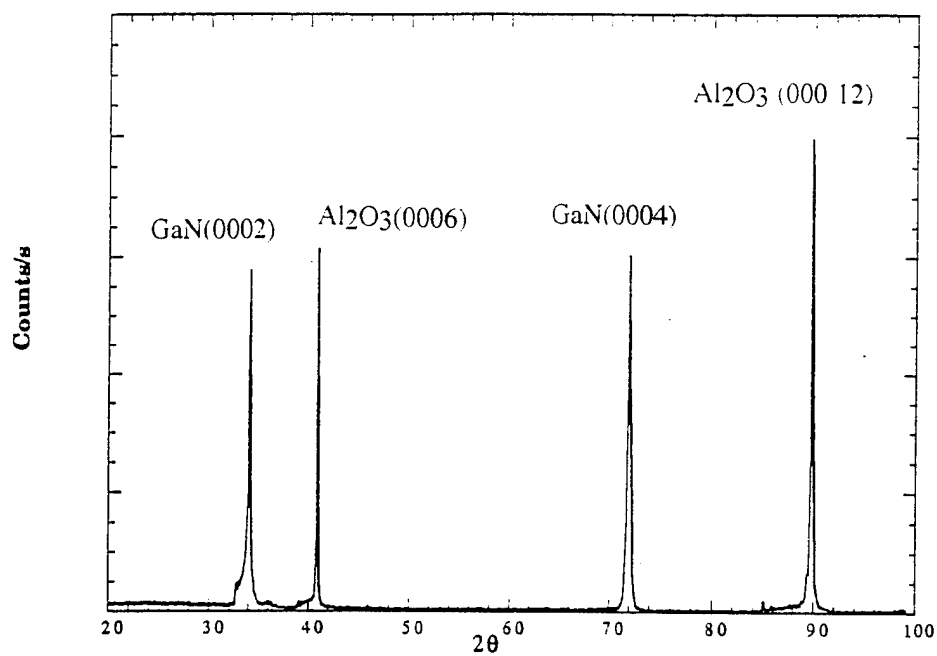

Figure 8. X-ray diffraction pattern collected from GaN film pictured in Figure 8.

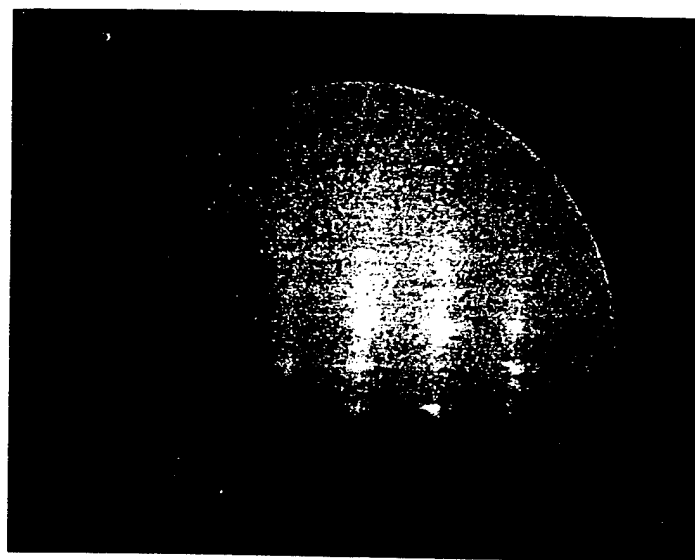

Figure 9. RHEED pattern collected from GaN film pictured in Figure 8.

Design of Dual-Beam System :

A dual seeded supersonic beam deposition system is currently under construction. This system will contain five chambers: load lock, sample transfer line, beam source chamber, deposition chamber and analysis chamber. A schematic overview of the system is presented in Figure 10.

The components of the new system fulfil the following specifications:

After the installation of samples, the load lock will be evacuated by a Drytel 31 combination molecular drag-diaphragm pump to $<10^{-5}$ Torr before samples can be lowered to access the sample transfer line. The sample transfer line is evacuated by a Cryo-pump and permits the movement of samples between the deposition chamber and the analysis chamber under $<10^{-8}$ Torr vacuum.

The deposition chamber is connected to the transfer line and the beam source chamber. A heater stage in this chamber can achieve sample temperatures of $\approx 600^{\circ}\text{C}$. This chamber also contains a RHEED system and a mass spectrometer mounted on a rotatable stage. The mass

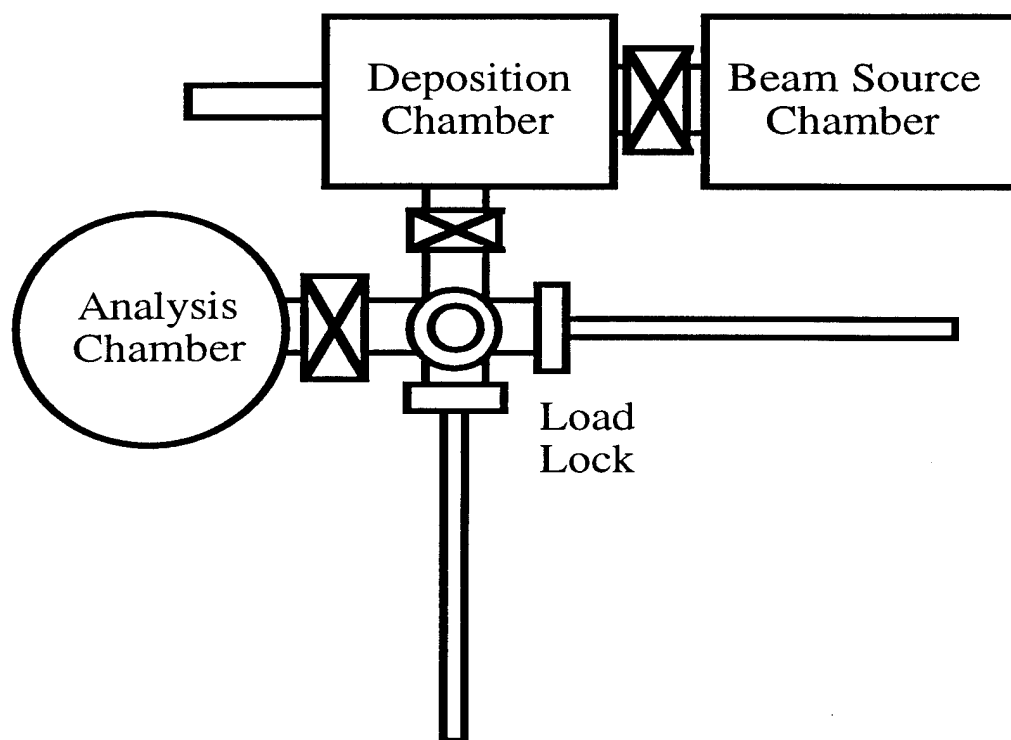

Figure 10. Schematic of dual beam deposition system and analysis chamber.

spectrometer may be configured to perform time of flight measurements of the seeded beams as well as being used for residual gas analysis and surface adsorption/desorption studies. Pumping of the deposition chamber will be accomplished with a magnetically levitated combination turbomolecular-molecular drag pump backed by a Fomblinized mechanical pump and an available cryo-cooled titanium sublimation pump. Up to two Knudsen evaporation cells may be fitted to this chamber in addition to an Oxford style R.F. plasma source or ECR plasma source. Once completely equipped, this versatile chamber may be employed for many varieties of sample cleaning and film deposition processes.

The beam source chamber is divided into two stages: a source stage and a differential pumping stage. Heated nozzles in the first stage generate the supersonic beams which pass through skimmers into the differential pumping stage where the beams are collimated. The differential pumping stage contains beam flags to interrupt the beams and chopper wheels that may be employed to generate a pulsed beam for time of flight measurements. The collimated beams then are directed into the deposition chamber where they are coincident on the substrate.

The last chamber in the new system is an ultra-high vacuum deposition chamber. The primary analysis technique to be performed in this chamber will be X-ray photoelectron spectroscopy with an angle resolved capability. The configuration of this chamber will also permit the performance of reflectance infrared spectroscopy. This chamber is evacuated by a combination Ion/ titanium sublimation pumping module.

At this point, the design of the source chamber is complete and the chamber is under construction. The design of the deposition chamber has been finalized and is being submitted to vendors for bids.

3.4 Conclusions

1. General conditions favoring the deposition of GaN films from a free jet source on Si(111) and Al₂O₃(0001) substrates have been determined.
2. C and O are the major contaminants found in the GaN films.
3. The C and O contaminant appear to be present in the highest concentrations on the film surface and at the film/substrate interface. Inadequate system cleanliness and in-air transfers have been identified as major contaminating agents.
4. An improvement in the degree of preferred crystallographic orientation of deposited GaN films with increasing nozzle temperature has been observed.
5. A dual beam deposition system has been largely designed and is currently under construction. This versatile system will have the capability of depositing films from dual seeded beams or from a selection of sources including Knudsen cells, gas sources and plasma assisted gas sources. The complete system will also offer the capability of performing time of flight measurements, desorption studies, RHEED characterization, XPS, angle resolved XPS and reflectance spectroscopy.

3.5 Future Plans

- Install skimmer into single beam system and develop conditions for depositing GaN films using a skimmed, NH₃ seeded He beam.
- Install TEG jet source in single beam system in attempt to deposit GaN films with a combination skimmed, NH₃ seeded He beam and free TEG seeded He beam.
- Continue design and construction of dual seeded beam deposition system.

3.6 References

1. J. H. Edgar, *J. Mater. Res.* 7, 235 (1992).
2. H. P. Maruska and J. J. Tietjen, *Appl. Phys. Lett.* 15, 327 (1969).
3. M. J. Paisley, Z. Sitar, J. B. Posthill and R. F. Davis, *J. Vac. Sci. and Technol.* B7, 701 (1989).
4. S. Strite, J. Ruan, Z. Li, A. Salvador, H. Chen, D. J. Smith, W. J. Choyke and H. Martoc, *J. Vac. Sci. and Technol.* B9, 1924 (1991).
5. T. Lei, M. Fanciulli, R. J. Molnar and T. D. Moustakas, *Appl. Phys. Lett.* 59, 944 (1991).
6. M. Mizuta, S. Fujieda, Y. Matsumoto and T. Kawamura, *Jpn. J. Appl. Phys.* 25, L945 (1986).
7. W. M. Yim, E. J. Stofko, P. J. Zanzucchi, J. I. Pankove, M. Ettenberg and S. L. Gilbert, *J. Appl. Phys.* 44, 292 (1973).
8. J. A. Sanjurjo, E. Lopez-Cruz, P. Vogh and M. Cardona, *Phys. Rev. B* 28, 4579 (1983).
9. H. P. Naruska, D. A. Stevens and J. I. Pankove, *Appl. Phys. Lett.* 22, 303 (1973).
10. J. R. Engstrom, D. A. Hansen, M. J. Furjanic and L. Q. Xia, *J. Chem. Phys.* 99, 4051 (1993).