

**REPORT DOCUMENTATION PAGE**

19960417 138

<b>1a. REPORT SECURITY CLASSIFICATION</b> Unclassified		<b>1b. RESTRICTIVE MARKINGS</b>	
<b>2a. SECURITY CLASSIFICATION AUTHORITY</b>		<b>3. DISTRIBUTION/AVAILABILITY OF REPORT</b> Unclassified/Unlimited	
<b>2b. DECLASSIFICATION/DOWNGRADING SCHEDULE</b>		<b>4. PERFORMING ORGANIZATION REPORT NUMBER(S)</b> Technical Report #10	
<b>5. MONITORING ORGANIZATION REPORT NUMBER(S)</b>		<b>6a. NAME OF PERFORMING ORGANIZATION</b> University of Minnesota	
<b>6b. OFFICE SYMBOL (if applicable)</b>		<b>7a. NAME OF MONITORING ORGANIZATION</b> Office of Naval Research	
<b>6c. ADDRESS (City, State, and Zip Code)</b> Dept. of Chemical Engineering & Materials Science University of Minnesota Minneapolis, MN 55455		<b>7b. ADDRESS (City, State and Zip Code)</b> 800 Quincy Street North Arlington, VA 22217-5000	
<b>8a. NAME OF FUNDING/SPONSORING ORGANIZATION</b> Office of Naval Research		<b>8b. OFFICE SYMBOL (if applicable)</b> ONR	
<b>9. PROCUREMENT INSTRUMENT IDENTIFICATION NUMBER</b> Contract No. N/N00014-93-1-0563		<b>10. SOURCE OF FUNDING NUMBERS</b>	
<b>8c. ADDRESS (City, State, and Zip Code)</b> 800 Quincy Street North Arlington, VA 22217-5000		<b>PROGRAM ELEMENT NO.</b>	<b>PROJECT NO.</b>
		<b>TASK NO.</b>	<b>WORK UNIT ACCESSION NO</b>
<b>11. TITLE (Include Security Classification)</b> Determination of Contact Angles and Surface Tensions with the Quartz Crystal Microbalance			
<b>12. PERSONAL AUTHOR(S)</b> Julie A. Last and Michael D. Ward			
<b>13a. TYPE OF REPORT</b> Technical	<b>13b. TIME COVERED</b> FROM 5/1/95 TO 6/30/96	<b>14. DATE OF REPORT (Year, Month, Day)</b> 96/4/8	<b>15. PAGE COUNT</b> 28
<b>16. SUPPLEMENTARY</b> to be published in Advanced Materials			
<b>17. COSATI CODES</b>		<b>18. SUBJECT TERMS (Continue on reverse if necessary and identify by block number)</b>	
<b>FIELD</b>	<b>GROUP</b>	Organic Conductor, Atomic Force Microscopy, Scanning Electron Microscopy, Nucleation	
<b>SUB-GROUP</b>			
<b>19. ABSTRACT (CONTINUE ON REVERSE AND IDENTIFY BY BLOCK NUMBER)</b> A method based on the quartz crystal microbalance (QCM) for measuring the sessile contact angles and surface energies of liquid-air and liquid-liquid interfaces is described. The method involves measurement of the frequency change accompanying the introduction of a small liquid droplet to the center of a vibrating quartz resonator, which comprises an AT-cut quartz crystal sandwiched between two gold electrodes. If the density and viscosity of the liquid are known, the contact angle between the droplet and the gold substrate surface can be determined directly. QCM measurements of contact angles formed between aqueous droplets and gold surfaces modified with various organosulfur monolayers having different surface energies agree with sessile contact angles determined by optical goniometry. Furthermore, the QCM method can be used to measure the contact angle formed between an aqueous droplet and the QCM surface when both are submerged under an immiscible solvent such as hexadecane. In this case the frequency change relies on the differences in the densities and viscosities of the water droplet and the fluid displaced by the droplet at the surface. The dependence of the contact angle on the concentration of surfactant in the aqueous droplet provides for determination of the critical micelle concentration (CMC) for aqueous phases in contact with air or an immiscible organic fluid. These measurements can be performed under conditions where contact angles cannot be measured readily, such as in the presence of opaque media or in the case of two liquids having similar refractive indices.			
<b>DTIC QUALITY INSPECTED 3</b>			
<b>20. DISTRIBUTION/AVAILABILITY OF ABSTRACT</b>		<b>21. ABSTRACT SECURITY CLASSIFICATION</b>	
<input type="checkbox"/> UNCLASSIFIED/UNLIMITED <input type="checkbox"/> SAME AS RPT <input type="checkbox"/> OTIC USERS		Unclassified	
<b>22a. NAME OF RESPONSIBLE INDIVIDUAL</b> Michael D. Ward		<b>22b. TELEPHONE (Include Area Code)</b> (612) 625-3062	
		<b>22c. OFFICE SYMBOL</b>	

**OFFICE OF NAVAL RESEARCH**

Contract N00014-93-1-0563

Technical Report No. 10

"Determination of Contact Angles and Surface Tensions  
with the Quartz Crystal Microbalance"

by

Zuxuan Lin and Michael D. Ward

to be published in

Analytical Chemistry

Department of Chemical Engineering and Materials Science  
University of Minneapolis  
421 Washington Avenue SE  
Minneapolis, MN 55455

April 1996

Reproduction in whole or in part is permitted for  
any purpose of the United States Government.

This document has been approved for public release and sale;  
its distribution is unlimited.

# Determination of Contact Angles and Surface Tensions with the Quartz Crystal Microbalance

Zuxuan Lin and Michael D. Ward\*

*Department of Chemical Engineering and Materials Science, University of Minnesota, 421  
Washington Ave SE, Minneapolis, MN 55455*

## Abstract

A method based on the quartz crystal microbalance (QCM) for measuring the sessile contact angles and surface energies of liquid-air and liquid-liquid interfaces is described. The method involves measurement of the frequency change accompanying the introduction of a small liquid droplet to the center of a vibrating quartz resonator, which comprises an AT-cut quartz crystal sandwiched between two gold electrodes. If the density and viscosity of the liquid are known, the contact angle between the droplet and the gold substrate surface can be determined directly. QCM measurements of contact angles formed between aqueous droplets and gold surfaces modified with various organosulfur monolayers having different surface energies agree with sessile contact angles determined by optical goniometry. Furthermore, the QCM method can be used to measure the contact angle formed between an aqueous droplet and the QCM surface when both are submerged under an immiscible solvent such as hexadecane. In this case the frequency change relies on the differences in the densities and viscosities of the water droplet and the fluid displaced by the droplet at the surface. The dependence of the contact angle on the concentration of surfactant in the aqueous droplet provides for determination of the critical micelle concentration (CMC) for aqueous phases in contact with air or an immiscible organic fluid. These measurements can be performed under conditions where contact angles cannot be measured readily, such as in the presence of opaque media or in the case of two liquids having similar refractive indices.

---

\* Author to whom correspondence should be addressed  
Submitted to *Anal. Chem.*, November 2, 1995  
Revised on January 26, 1996

## Introduction

The quartz crystal microbalance (QCM) comprises a thin AT-cut quartz crystal sandwiched between two gold electrodes that provide an alternating electric field, which induces a shear vibration of the quartz crystal with resonant frequencies in the MHz region.<sup>1</sup> The ease of measuring this resonant frequency with high precision has made the QCM an extremely useful tool for measuring minute changes in mass associated with the deposition or loss of a foreign material from the QCM electrode surface.<sup>2</sup> The basis for these measurements is the transverse propagation of an acoustic shear wave, generated by the alternating electric field, through the quartz crystal and the foreign material on the QCM surface. If the foreign material is assumed to be rigidly elastic, the series resonant frequency provides a direct measurement of mass changes on the surface of the QCM according to eq. (1),<sup>3</sup> where  $\Delta f$  is the measured frequency shift,  $f_0$  the initial (resonant) frequency of the quartz crystal,  $\Delta m$  the mass change,  $A$  the piezoelectrically active area defined by two gold excitation electrodes,  $\rho_q$  the density of quartz ( $2.648 \text{ g cm}^{-3}$ ) and  $\mu_q$  the shear modulus ( $2.947 \times 10^{11} \text{ dynes cm}^{-2}$  for AT-cut quartz).

$$\Delta f = \frac{-2 f_0^2 \Delta m}{A \sqrt{\rho_q \mu_q}} \quad (1)$$

Numerous investigations in the last decade have illustrated the capabilities of the QCM for measuring mass changes occurring at one of the QCM electrodes while that surface is immersed in a liquid.<sup>4</sup> However, the resonant frequency is also influenced by the viscosity and density of the fluid in contact with the QCM surface because the surface of the quartz resonator is at an antinode of the shear wave generated by crystal vibration. This enables propagation of the shear wave, with displacement in the direction of crystal shear motion, into the solution along a direction normal to the QCM surface. The amplitude of the shear wave in a Newtonian liquid is described by an exponentially damped cosine function,

decaying to  $1/e$  of its original amplitude at a decay length  $\delta$ . The value of  $\delta$  is determined by the resonant frequency, and the viscosity and density of the liquid, according to eq. (2), where  $\eta_L$  is the liquid viscosity, and  $\rho_L$  is the liquid density ( $\delta \approx 2500 \text{ \AA}$  for a 5 MHz shear wave in water).<sup>5</sup> Consequently, the frequency shift exhibited by the QCM upon immersion in liquid depends upon these quantities according to eq. (3). This frequency change corresponds to an "effective" mass of a liquid layer contained within the decay length  $\delta$ . In fact, eq. (3) can be obtained from eq. (1) if it is assumed that  $\Delta m/A = \rho_L \delta/2$ , that is, by assuming that the liquid layer thickness sensed by the QCM is  $\delta/2$ .

$$\delta = (\eta_L/\pi f_0 \rho_L)^{1/2} \quad (2)$$

$$\Delta f = - f_0^{3/2} \sqrt{\frac{\rho_L \eta_L}{\pi \rho_q \mu_q}} \quad (3)$$

Recently, we demonstrated that the ability of the QCM to detect fluids in contact with its surface could be exploited to measure the rates at which thin liquid films spread on solid substrates.<sup>6</sup> Spreading rates were calculated from the frequency changes accompanying the introduction of a small aqueous droplet to the center of the quartz resonator and its subsequent radial spreading across the gold electrode. These determinations relied on calibration of the radially dependent sensitivity,  $S(r)$ , of the QCM with respect to the distance from the center of the resonator, which for rigid films has a Gaussian-like profile.<sup>7,8,9,10,11</sup> This is a consequence of the non-uniform velocity,  $V_x(r,\theta)$ , of the crystal in the shear ( $x$ ) direction, which results from the finite electrode size. The radial sensitivity profile for the Newtonian aqueous fluid was determined by measuring the frequency change resulting from the introduction of small water droplets of known volumes (whose heights exceeded the decay length  $\delta$ ) to the center of the QCM gold electrode, which had been modified with an organosulfur monolayer so that the droplet formed a reproducible and well-defined sessile

contact angle. This procedure revealed radial sensitivity profiles which were essentially identical to those reported for rigid films. Consequently, the frequency change associated with the area of a liquid droplet in contact with the resonator can be described according to eq 4, where  $S$  is the differential sensitivity ( $df/dm$ ), and  $m(r, \theta)$  represents the radial and angular mass distribution. In the case of a Newtonian fluid,  $m(r, \theta)$  is described by the effective mass contained within the decay length  $\delta$ .

$$\Delta f = \int_0^{2\pi} \int_0^r S(r, \theta) m(r, \theta) r dr d\theta \quad (4)$$

We describe herein a QCM method for determining sessile contact angles of liquid droplets on solid surfaces and their corresponding surface tensions which relies on the converse of the aforementioned calibration procedure. That is, these quantities are deduced from changes in the resonant frequency that accompany the introduction of a liquid droplet to the QCM surface. Contact angles on solid surfaces, which provide a convenient measure of surface wettability and energy,<sup>12,13</sup> typically are measured directly using optical goniometry if the interface can be observed directly.<sup>14</sup> However, direct observation may not be possible under some conditions, for example, if the surface and the contacting drop are submerged beneath a second liquid which is opaque or if the refractive indices of the two liquids are similar so that the liquid-liquid interface cannot be discerned. The QCM method enables convenient measurement of sessile contact angles of aqueous fluids on solid surfaces in air or under organic liquids. This approach also enables determination of the surface tension of liquid-liquid interfaces and the critical micelle concentration of surfactants under a variety of conditions.

## Experimental Section

**Apparatus.** The experimental apparatus consisted of a specially constructed liquid cell that accommodated 5-MHz AT-cut plano-plano quartz crystals (Valpey-Fisher, Hopkinton,

MA) (Figure 1), similar to that previously described.<sup>15</sup> The quartz crystal was mounted between two 9-mm O-rings confined by standard 18/9 glass O-ring fittings and held with a metal clamp. The upper chamber was fabricated from a glass O-ring fitting and a thick wall capillary with a bore size of 2 mm diameter, through which was inserted a syringe (model no. S-1100 micrometer syringe, Gilmont Instrument, Barrington, IL) for introduction of liquid to the QCM surface. The liquid droplet volume employed in this study was typically  $2.0 \pm 0.2$   $\mu\text{L}$ . The thick wall capillary also provided a solid surface at a fixed distance from the QCM surface so that contributions from longitudinal standing waves were minimized.<sup>16</sup> This configuration resulted in a QCM stability better than  $\pm 1$  Hz for periods of several hours. Gold electrodes ( $\approx 2000$  Å thick) were deposited on titanium underlayers ( $\approx 200$  Å thick) on both sides of the crystals by electron beam evaporation. The electrode patterns were arranged so that the gold leads on opposite sides running from the outer edges of the crystal to the center circular pad do not overlap. An asymmetric electrode format was used in which the upper electrode onto which the solution was added had a larger radius ( $r_{e,\text{upper}} = 0.6$  cm,  $A = 1.13$  cm<sup>2</sup>) than the lower electrode ( $r_{e,\text{lower}} = 0.45$  cm,  $A = 0.64$  cm<sup>2</sup>). The resonant frequency of the quartz crystal was measured by inserting the quartz crystal into a feedback loop of a broad-band radio frequency amplifier in a conventional oscillator circuit. The circuit was driven by a Hewlett Packard 6234A dual-output power supply (Hewlett-Packard Corp., San Diego, CA), and frequency measurements were performed with a Hewlett Packard 5384A frequency counter, with a precision of 0.1 Hz at a gate time of 0.1 s. Contact angle measurements were also performed with an NRL Contact Angle Goniometer (Rame-Hart Inc., Mountain Lakes, NJ), using 2  $\mu\text{L}$  liquid drops for each measurement.

[Figure 1]

**Materials.** n-hexadecane (Sigma) and sodium dodecyl sulfate (Aldrich) were used as obtained without further purification. Milli-Q reagent water (18 M $\Omega$ ) (Millipore Corp.,

Bedford, WA) was used for the preparation of all aqueous solutions. Organosulfur monolayers on the gold electrodes of the resonators were prepared by immersing the resonators in 1 mM ethanol solution of the alkanethiols, which included  $\text{HS}(\text{CH}_2)_{15}\text{CH}_3$ ,  $\text{HS}(\text{CH}_2)_{16}\text{OH}$ , or mixtures of both. The crystals were rinsed with ethanol three times and dried with nitrogen gas prior to measurements.

**Procedure.** Determination of the QCM parameter  $C$ , defined in Results and Discussion, was accomplished by the continual addition of controlled amounts of water to the center of the resonator while measuring the resonant frequency. The surface of the resonator was modified with organosulfur monolayers to provide well-defined contact angles between the surface and the sessile water droplets occupied an area proportional to their contact angle and volume. This procedure was performed for droplets having  $r \ll r_e$  (see Results and Discussion). Contact angle measurements in air were performed by placing a liquid drop on the center of the upper QCM surface while measuring  $\Delta f$ . Contact angle measurements in liquids were performed by immersing the upper side of the QCM in fluid 1, followed by placing a small droplet of fluid 2 on the center of the QCM while measuring  $\Delta f$ . After each measurement, the QCM cell was disassembled and the quartz crystal rinsed with water, or with pentane if the crystal had been immersed in hexadecane. The crystals were dried by nitrogen prior to next measurement. The contact angles were determined from the measured  $\Delta f$  using the Newton-Raphson method applied to eqs. (17) or (18), depending upon the experimental conditions. The program is available upon request.

## Results and Discussions

**Principles.** Liquid films in contact with the QCM do not behave as rigid layers due to the Newtonian properties of the liquid. Rather, the acoustic high-frequency shear wave propagates across an antinode at the crystal-liquid interface, propagating further through the liquid with a decay length which is dependent upon the liquid viscosity and density. The velocity and amplitude of crystal vibration along the shear direction, taken as the  $x$ -axis, is

largest in the center of the electroded region of the resonator and decays monotonically to negligible values at the electrode edges. The radial dependence of crystal motion has been described for a circular resonator geometry by Bessel and modified Bessel functions.<sup>8,17</sup> However, we recently demonstrated for Newtonian liquids that the angularly dependent radial sensitivity  $S(r, \theta)$  can be described adequately by a Gaussian function (eq. 5), where  $K$  represents the maximum sensitivity at the center of the resonator ( $r = 0$ ),  $\beta$  is a constant that defines the steepness of the sensitivity dependence on  $r$ , and  $r_e$  is the QCM electrode radius.<sup>6</sup> The general characteristics of  $S(r, \theta)$ , including the value of  $\beta$ , measured for Newtonian aqueous liquids were very similar to those reported previously for rigidly elastic layers.<sup>7,8</sup> It should be noted that in this form  $S(r, \theta)$ , actually represents an angle-averaged quantity in which the angular dependence is subsumed by the constant  $\beta$ . Therefore, the angular dependence does not appear on the right hand side of eq. (5). This relationship indicates that the resonant frequency will be dependent upon the radius of a liquid film centered on the surface of the QCM.

$$S(r, \theta) = S(r)_\theta = K \exp(-\beta r^2/r_e^2) \quad (5)$$

Consider a liquid film completely covering the QCM surface ( $r \geq r_e$ ) with a thickness much larger than the decay length  $\delta$  ( $\delta = 2500\text{\AA}$  in water for a 5 MHz shear wave). The frequency response of the QCM to this liquid film can be described in terms of an "effective rigid layer thickness,"  $t_{\text{eff}}$ , which is proportional to  $\delta$  (eq. 6). The proportionality constant  $\alpha$  can be shown to be equal to 1/2 upon comparison of eqs. (1) and (3). Therefore, the QCM can be considered as responding to the mass of the liquid confined within  $\delta/2$  of the resonator surface. Consequently, if the liquid film thickness exceeds  $\delta$  throughout the wetting process, the thickness of the liquid film can be considered as having a constant value of  $\delta/2$ . This is equivalent to stating that  $m(r, \theta) / \pi r^2$  is constant for all  $r$ . The effective mass detected can be described generally by eq. (7).

$$t_{\text{eff}} = \alpha \delta \quad (6)$$

$$m = t_{\text{eff}} \rho_L = \alpha \delta \rho_L \quad (7)$$

The work described here is concerned with the measurement of contact angles formed between a fluid (designated fluid 2) and the QCM surface, which is in contact with air or submerged under a different fluid, which are both designated as fluid 1 (Figure 2). The frequency change due to the loading of the QCM by a film of fluid 1 (in the absence of another fluid) having a radius  $r$  is given by eq (8), where  $\delta_1 = \sqrt{\frac{\eta_1}{\pi f_o \rho_1}}$ ,  $f_o$  is the frequency of the unloaded QCM, and  $\rho_1$  and  $\eta_1$  are the density and viscosity of fluid 1, respectively.

[Figure 2]

$$\Delta f_1 = -\pi \alpha \delta_1 \rho_1 K \frac{r_e^2}{\beta} [1 - \exp(-\beta \frac{r^2}{r_e^2})] \quad (8)$$

Consider a small droplet of fluid 2 with a radius of  $r$  and height exceeding  $\delta$  located at the center of the QCM and surrounded by fluid 1, which covers the remaining the QCM surface. The QCM frequency will differ from the unloaded value by an amount  $\Delta f_2$ , given by eq. (9), where  $\delta_2 = \sqrt{\frac{\eta_2}{\pi f_o \rho_2}}$ , and  $\rho_2$  and  $\eta_2$  are density and viscosity of fluid 2, respectively. The term  $r_o$  is included here to account for bare regions of the quartz crystal beyond the electrode boundaries which are also covered with fluid 1. Consequently, the frequency change accompanying the addition of a small droplet of fluid 2 to the center of a QCM already immersed in fluid 1 is described by eq (10), which is simply the difference between eqs. (9b) and (8). It should be noted that  $r_o$  is eliminated in this manner, and therefore is of no consequence in the QCM measurements.

$$\Delta f_2 = -\left\{ \int_r^{r_o} K \exp(-\beta \frac{r^2}{r_e^2}) \alpha \delta_1 \rho_1 (2\pi r dr) + \int_0^r K \exp(-\beta \frac{r^2}{r_e^2}) \alpha \delta_2 \rho_2 (2\pi r dr) \right\} \quad (9a)$$

$$\Delta f_2 = -\pi\alpha K \frac{r_e^2}{\beta} \left\{ \delta_1 \rho_1 \left[ \exp\left(-\beta \frac{r^2}{r_e^2}\right) - \exp\left(-\beta \frac{r_0^2}{r_e^2}\right) \right] + \delta_2 \rho_2 \left[ 1 - \exp\left(-\beta \frac{r^2}{r_e^2}\right) \right] \right\} \quad (9b)$$

$$\Delta f = \Delta f_2 - \Delta f_1 = \pi\alpha K \frac{r_e^2}{\beta} \left[ 1 - \exp\left(-\beta \frac{r^2}{r_e^2}\right) \right] [\delta_1 \rho_1 - \delta_2 \rho_2] \quad (10)$$

The validity of these expressions can be demonstrated with two special cases:

(I) Fluid 1 is air, which is displaced from the QCM surface by a droplet of fluid 2 with radius  $r$ . In this case  $\delta_1 \rho_1 \approx 0$ , and eq. (10) simply becomes eq. (11), which is identical in form to eq. (8), as well as the expression for a liquid droplet in contact with the QCM derived previously (eq. 9, ref. 6a). In the limit  $r = \infty$ , that is, with the entire QCM surface covered with a fluid 2 having a thickness exceeding  $\delta_1$ , eq (11) becomes identical to eq (3).

$$\Delta f = -\pi\alpha\delta_2\rho_2 K \frac{r_e^2}{\beta} \left[ 1 - \exp\left(-\beta \frac{r^2}{r_e^2}\right) \right] \quad (11)$$

(II) Fluid 2 is a small air bubble in contact with the QCM surface, submerged beneath fluid 1. In this case,  $\delta_2 \rho_2 = 0$ , and eq. (10) becomes eq (12). If the air bubble covers the entire QCM surface the frequency of the QCM will increase by an amount equivalent to the decrease observed from liquid loading (eq 8).

$$\Delta f = \pi\alpha\delta_1\rho_1 K \frac{r_e^2}{\beta} \left[ 1 - \exp\left(-\beta \frac{r^2}{r_e^2}\right) \right] \quad (12)$$

These expressions illustrate that, if the densities and viscosities of the two fluids and the constants for the QCM are known, the contact radius of a droplet of fluid 2 can be determined from the frequency change. The expressions can be simplified further by using droplets of fluid 2 whose size is smaller than those of the QCM electrodes. In this case eq. (10) can be simplified to eq. (13) ( $r \ll r_e$  and  $e^{-x} \approx 1-x$  for  $x \ll 1$ ), where  $C = -\pi\alpha K \delta_2 \rho_2$ .

This is simply equivalent to stating that in the vicinity of  $r = 0$  the sensitivity function is relatively flat, and therefore the exponential character can be disregarded.

$$\Delta f = \pi\alpha K(\delta_1\rho_1 - \delta_2\rho_2)r^2 \quad (13a)$$

$$\Delta f = C\left(1 - \frac{\delta_1\rho_1}{\delta_2\rho_2}\right)r^2 = C\left(1 - \frac{\sqrt{\rho_1\eta_1}}{\sqrt{\rho_2\eta_2}}\right)r^2 \quad (13b)$$

If  $\delta_1\rho_1 \approx 0$  (fluid 1 is air), eq. (13) simply becomes eq. (14). This enables determination of the constant C by a simple procedure in which the volume of a small droplet of fluid 2 forming a known, well-defined contact angle with the solid surface is varied while measuring  $\Delta f$ . The volume of the droplet,  $V_d$ , contacting the solid surface is given by eq. (15), where R is the radius of curvature and  $\theta$  is the sessile contact angle formed between fluid 2 and the solid surface. The contact radius  $r$  is given by  $r = R\sin\theta$ , which upon substitution into eq. (15) and rearrangement affords eq. (16). Consequently, if  $V_d$  and  $\theta$  are known the interfacial radius  $r$  can be determined. The value of C determined in this manner for a 5 MHz overtone polished QCM varied somewhat from crystal to crystal, ranging from -75 to -115 Hz/mm<sup>2</sup> for water droplets in air (Figure 3).

[Figure 3]

$$\Delta f = Cr^2 \quad (14)$$

$$V_d = \frac{1}{3}\pi R^3(2 - 3\cos\theta + \cos^3\theta) \quad (15)$$

$$r^2(2 - 3\cos\theta + \cos^3\theta)^{2/3} - \left(\frac{3V_d}{\pi}\right)^{2/3}(1 - \cos^2\theta) = 0 \quad (16a)$$

$$r^2 = \frac{\left(\frac{3V_d}{\pi}\right)^{2/3} (1 - \cos^2 \theta)}{(2 - 3\cos \theta + \cos^3 \theta)^{2/3}} \quad (16b)$$

**Determination of contact angles in air.** Inspection of eq. (16) reveals that if the interfacial contact radius and droplet volume are known,  $\theta$  can be determined. Using eq. (14), the relationship of the frequency change to  $\theta$  formed by a small fluid droplet is given by eq. (17).

$$\Delta f = C \frac{\left(\frac{3V_d}{\pi}\right)^{2/3} (1 - \cos^2 \theta)}{(2 - 3\cos \theta + \cos^3 \theta)^{2/3}} \quad (17)$$

This can be demonstrated by measurement of the contact angles formed between drops of 1.0 M Na<sub>2</sub>SO<sub>4</sub> and the QCM gold electrodes, whose surface energies are varied by modification with organosulfur monolayers. Solutions of Na<sub>2</sub>SO<sub>4</sub> were chosen to demonstrate generality as the calibration procedure was performed with pure deionized water; a 1.0 M Na<sub>2</sub>SO<sub>4</sub> aqueous solution has nearly the same surface tension as pure water but it has different viscosity and density values ( $\rho\eta = 1.81 \text{ cp g cm}^{-3}$ ).<sup>18</sup> The surface energies of the organosulfur monolayers were varied by controlling their composition with respect to the amounts of HS(CH<sub>2</sub>)<sub>15</sub>CH<sub>3</sub> and HS(CH<sub>2</sub>)<sub>16</sub>OH on the surface. Introduction of a 2  $\mu$ L drop of 1.0 M Na<sub>2</sub>SO<sub>4</sub> to the center of the QCM resulted in a decrease of resonant frequency, with  $\Delta f$  ranging from -70 to -270 Hz (Table 1). The magnitude of the frequency shift increased with increasing surface energy (i.e., an increase in the amount of surface OH), consistent with increasing contact area between the droplet and the surface. The contact angles were deduced from the measured  $\Delta f$  with the Newton-Raphson method applied to eq. (17), which provides the best numerical fit for  $\Delta f$  and values of C (Table 2). The calculations were performed with C values measured specifically for the quartz resonator on which the contact angles were measured, as well as with a C value obtained from averaging numerous resonators (84.6 Hz/mm<sup>2</sup>). The contact angles measured in this manner were in very good agreement with those determined by optical goniometry. Although a slightly

better agreement was obtained for the QCM by using the individually determined C, it is more convenient to use the averaged value of C. Similar experiments performed using hexadecane ( $\rho\eta = 2.572 \text{ cP g cm}^{-3}$ ) gave good agreement with optical goniometry (Table 3).

[Table 1]

[Table 2]

[Table 3]

**Determination of contact angles in a fluid medium.** When hexadecane (HD) was added to completely cover the upper side of a QCM modified with organosulfur monolayers a frequency decrease, as expected from eq. (3), was observed. When a 2  $\mu\text{L}$  droplet of water was placed on the center of the QCM so as to displace an equal volume of HD from that region, the frequency *increased* by an amount that depended upon the monolayer surface energy (Table 1). The frequency increase upon adding the aqueous droplet can be attributed to the smaller viscosity of water. The contact angle formed between the water droplet and the QCM surface was calculated from  $\Delta f$  using the Newton-Raphson method applied to eq. (18), which is a modified form of equation (17) that accounts for the difference between the densities and viscosities of the two fluids.

$$\Delta f = C \left(1 - \frac{\delta_1 \rho_1}{\delta_2 \rho_2}\right) r^2 = C \left(1 - \frac{\sqrt{\rho_1 \eta_1}}{\sqrt{\rho_2 \eta_2}}\right) \frac{\left(\frac{3V_d}{\pi}\right)^{2/3} (1 - \cos^2 \theta)}{(2 - 3\cos \theta + \cos^3 \theta)^{2/3}} \quad (18)$$

[Table 3]

According to eq. (18), the frequency change is sensitive to  $\frac{\sqrt{\rho_1 \eta_1}}{\sqrt{\rho_2 \eta_2}}$  and the solid surface energy (described in terms of  $\cos\theta$ ), the latter affecting the interfacial contact radius. The sensitivity of  $\Delta f$  to changes in  $\theta$  decreases as the value of  $\frac{\sqrt{\rho_1 \eta_1}}{\sqrt{\rho_2 \eta_2}}$  approaches one

(Figure 4). The magnitude of  $\Delta f$  also decreases as  $\theta$  increases owing to the smaller interfacial area displaced by the water droplet. Assuming a typical detection limit of 1 Hz for a 5 MHz resonator and a contact angle for a 2  $\mu$ L water droplet (fluid 2) of  $\theta = 140^\circ$ , reliable measurements can be made only if  $\frac{\sqrt{\rho_1 \eta_1}}{\sqrt{\rho_2 \eta_2}} < 0.95$  or  $\frac{\sqrt{\rho_1 \eta_1}}{\sqrt{\rho_2 \eta_2}} > 1.05$ . The accuracy of these measurements can be influenced by various experimental factors. Errors due to frequency instabilities are assumed to be small because it is a frequency change that is measured, and this is performed over a short time scale in which the frequency is accurate to within  $\pm 1$  Hz. Errors due to inaccurate drop volumes are also expected to be small. The values of  $\theta$  are influenced slightly by errors in the drop volume  $V_d$ , although the magnitude of the error depends upon the value of  $\theta$ . A 10% error in  $V_d$  results in errors of  $\pm 1^\circ$  and  $\pm 4^\circ$  at  $\theta = 140^\circ$  and  $80^\circ$ , respectively. Similar errors at these  $\theta$  values result if  $\rho_1 \eta_1$  or  $\rho_2 \eta_2$  varies by  $\pm 10\%$ .

[Figure 4]

**Influence of surfactants.** The sensitivity of the QCM to changes in contact angle can be further illustrated by measurements performed for aqueous droplets containing various concentrations of sodium dodecyl sulfate (SDS). Increasing concentration of SDS in the aqueous phase will result in a decreasing surface tension of the air-water or the HD-water interface and a corresponding increase in the areas of these interfaces and decrease in the contact angles. Consequently, the contact area between the aqueous droplet and the QCM will increase, and the magnitude of  $\Delta f$  will increase with increasing SDS concentration (becoming more negative for air-water and more negative for HD-water). Indeed, the contact angles measured with the QCM decrease monotonically with increasing SDS concentration in a manner identical to that measured by optical goniometry (Table 4, Figure 5). This decrease continues until the SDS concentration reaches approximately  $\approx 8$  mM, which is surmised to be indicative of the CMC for SDS (the reported CMC is 8.2 mM<sup>25</sup>). Recently, a

QCM-based method for determining the CMC of ionic surfactants was reported which was based on the influence of solution conductivity from the ionic species on the QCM frequency.<sup>19</sup> However, the method described here can be used for both ionic and non-ionic surfactants.

[Table 4]

[Figure 5]

To further illustrate the capabilities of the QCM, the measured contact angles under HD can be expressed in terms of their relationship to the HD-water interfacial tension. There are a variety of methods to determine surface tension of a liquid-air interface,<sup>12</sup> and many of them can be modified for measurements of interfacial energy between two immiscible liquids.<sup>20,21,22</sup> For example, the Wilhelmy plate method, which is convenient for measuring the surface tension of a liquid-air interface,<sup>23</sup> can be used for this purpose. The interfacial energy between two liquids can be determined from Young's equation if the contact angles  $\theta_1$  and  $\theta_2$ , corresponding to the contact angles formed between a solid surface and fluids 1 and 2 in air, respectively, and the surface energies  $\gamma_{s,air}$ ,  $\gamma_{1,air}$ , and  $\gamma_{2,air}$  are known. The Young's equations for the respective fluids are given by eqs. (19a) and (19b). If the solid surface is identical in both cases, these equations can be combined into eq (20) by eliminating  $\gamma_{s,air}$ .

$$\gamma_{s,air} = \gamma_{1,air} \cos\theta_1 + \gamma_{1,s} \quad (19a)$$

$$\gamma_{s,air} = \gamma_{2,air} \cos\theta_2 + \gamma_{2,s} \quad (19b)$$

$$\gamma_{1,air} \cos\theta_1 + \gamma_{1,s} = \gamma_{2,air} \cos\theta_2 + \gamma_{2,s} \quad (20)$$

If the contact angle defined by two fluids at the fluid-substrate interface is defined as  $\theta_3$ , the interfacial energy  $\gamma_{1,s}$  is given by eq (21). If the contact angles  $\theta_1$ ,  $\theta_2$ ,  $\theta_3$ , and the surface tensions  $\gamma_{1,air}$ ,  $\gamma_{2,air}$  are known, the energy of the liquid-liquid interface  $\gamma_{1,2}$  can be

deduced using eq (22). These expressions neglect the disjoining pressure of the adsorbed liquid film, and the three-phase contact line tension, which might cause errors but generally are negligible.<sup>24</sup>

$$\gamma_{1,s} = \gamma_{1,2} \cos \theta_3 + \gamma_{2,s} \quad (21)$$

$$\gamma_{1,2} \cos \theta_3 = \gamma_{1,\text{air}} \cos \theta_1 - \gamma_{2,\text{air}} \cos \theta_2 \quad (22)$$

The surface tension of water ( $\gamma_{2,\text{air}}$ ) and hexadecane ( $\gamma_{1,\text{air}}$ ) and their interfacial energy ( $\gamma_{1,2}$ ) at 20°C are reported to be 72.8, 30.0 and 52.1 dynes/cm, respectively.<sup>25</sup> The interfacial energy of the hexadecane-water interface, calculated from contact angles measured with the QCM using eqs. (18) and (22), was 51.4 dynes/cm. This value also was in good agreement with the value determined from the contact angle measured by optical goniometry (50.4 dynes/cm). Furthermore values of  $\gamma_{1,2}$  determined in this manner at different SDS concentrations exhibit the pronounced change in slope at approximately 8 mM with a limiting value of  $\gamma_{1,2} = 16$  dynes/cm. This value was constant for measurements performed at SDS concentrations above 8 mM and up to 20 mM, the highest concentration examined.

## Conclusions

The dependence of the QCM resonant frequency on the area of contact between a liquid droplet and the QCM surface, and its sensitivity to differences in densities and viscosities of different fluids, enables direct determination of contact angles of liquid droplets formed on the QCM surface. These measurements can be performed under air or under another fluid which is immiscible with the liquid under examination, with precision that is comparable to that of optical goniometry. This capability can provide estimates of the critical micelle concentrations of surfactants. The ability to perform these measurements with a QCM may be advantageous when solution opacity or small differences in refractive

indices of the two fluid phases interferes with optical measurement of contact angles. We also anticipate that the well demonstrated ability to use the QCM electrode as a working electrode in an electrochemical cell can be exploited to examine changes in surface tension that may accompany electrochemical processes.

**Acknowledgment.** This work was supported by the Center for the Interfacial Engineering (CIE), an NSF Engineering Research Center.

---

## References

- <sup>1</sup> Ward, M. D.; Buttry, D. A. *Science*, **1990**, *249*, 1000.
- <sup>2</sup> Lu, C.; Czanderna, W. ed. *Applications of Piezoelectric Quartz Crystal Microbalances*: Elsevier: New York, 1984.
- <sup>3</sup> Sauerbrey, G. *Z. Phys.* **1959**, *155*, 206.
- <sup>4</sup> Buttry, D. A.; Ward, M. D. *Chem. Rev.*, **1992**, *92*, 1355, and references therein.
- <sup>5</sup> Kanazawa, K. K.; Gordon, J. G. II *Anal. Chim. Acta*, **1985**, *175*, 99.
- <sup>6</sup> (a) Lin, Z.; Hill, R. M.; H. T. Davis; Ward, M. D. *Langmuir* **1994**, *10*, 4060. (b) Lin, Z.; Stoebe, T.; Hill, R. M.; H. T. Davis; Ward, M. D., *Langmuir*, in press.
- <sup>7</sup> Martin, B. A.; Hager, H. E. *J. Appl. Phys.* **1989**, *65*, 2630.
- <sup>8</sup> Ward, M. D.; Delawski, E. J. *Anal. Chem.* **1991**, *63*, 886.
- <sup>9</sup> Hillier, A. C.; Ward, M. D. *Anal. Chem.* **1992**, *64*, 2539.
- <sup>10</sup> Bacskai, J.; Lang, G.; Inzelt, G. *J. Electroanal. Chem.* **1991**, *319*, 55.
- <sup>11</sup> Gabrielli, C.; Keddari, M.; Torresi, R. *J. Electrochem. Soc.* **1991**, *138*, 2657.
- <sup>12</sup> Adamson, A. W. *Physical Chemistry of Surfaces*, 1st ed: Interscience Publisher, Inc.: New York, 1960.
- <sup>13</sup> Schrader, M. E.; G. I. Loeb, ed. *Modern Approaches to Wettability, Theory and Applications*: Plenum Press: New York, 1992.
- <sup>14</sup> Miller, C. A.; Neogi, P. *Interfacial Phenomena: Equilibrium and Dynamic Effect*: Marcel Dekker Inc.: New York, 1985.
- <sup>15</sup> Ward, M. D. *J. Phys. Chem.* **1988**, *92*, 2049.
- <sup>16</sup> Lin, Z.; Ward, M. D. *Anal. Chem.* **1995**, *67*, 685.
- <sup>17</sup> Sekimoto, H. *IEEE Trans. Sonics Ultrasonics* **1984**, *31*, 664.
- <sup>18</sup> Weast, R. C.; Astle, M. J. *CRC Handbook of Chemistry and Physics*, 63rd ed.: CRC Press: Boca Raton, FL 1982.
- <sup>19</sup> Shen, D. Z.; Xu, Y. J.; Nie, L. H.; Yao, S. Z. *Talanta* **1994**, *41*, 1993.

- 
- <sup>20</sup> Wilkinson, M. C. *J. Colloid Sci.* **1972**, *40*, 14.
- <sup>21</sup> Fleureau, J. M. *SPE Form. Eval.* **1992**, June, 132.
- <sup>22</sup> Liggieri, L.; Passerone, A. *High Temp. Tech.* **1989**, *7*, 82.
- <sup>23</sup> Wilhelmy, L. *Ann. Phys.* **1863**, *199*, 177.
- <sup>24</sup> Zisman, W. A. ed. *Contact Angles, Wettability and Adhesion*, Advances in Chemistry Series, Vol. 43: Am. Chem. Soc.: Washington DC, 1964.
- <sup>25</sup> Davies, J. T.; Rideal, E. K. *Interfacial Phenomena*, 1st ed.: Academic Press: New York, 1961.

**Table 1.** Changes in the resonant frequency,  $\Delta f$ , resulting from addition of a 2  $\mu\text{L}$  drop of deionized water to the center of the QCM on various monolayer modified surfaces in air and in hexadecane (HD).

<u>Surface (CH<sub>3</sub>:OH)<sup>a</sup></u>	<u><math>\Delta f</math> (Hz), Water/air</u>	<u><math>\Delta f</math> (Hz), Water/HD</u>
10:0	-70	10
7:3	-95	17
5:5	-137	19
4:6	-156	34
2:8	-175	82
0:10	-268	132

<sup>a</sup> Nominal composition based on relative amounts of HS(CH<sub>2</sub>)<sub>15</sub>CH<sub>3</sub> and HS(CH<sub>2</sub>)<sub>16</sub>OH in the ethanol solutions used to prepare the monolayers.

**Table 2.** Comparison of contact angles measured with different methods for 1.0 M Na<sub>2</sub>SO<sub>4</sub> drops on various organosulfur monolayer surfaces.

<u>Surface (CH<sub>3</sub>:OH)<sup>a</sup></u>	<u>OCM</u>	<u>OCM (Average C)<sup>b</sup></u>	<u>Goniometer</u>
10:0	107° ( $\pm$ 2°)	107° ( $\pm$ 2°)	107° ( $\pm$ 1°)
7:3	91° ( $\pm$ 2°)	84° ( $\pm$ 2°)	90° ( $\pm$ 1°)
5:5	68° ( $\pm$ 3°)	68° ( $\pm$ 3°)	70° ( $\pm$ 2°)
4:6	57° ( $\pm$ 1°)	61° ( $\pm$ 2°)	52° ( $\pm$ 1°)
2:8	41° ( $\pm$ 1°)	43° ( $\pm$ 1°)	42° ( $\pm$ 2°)
0:10	27° ( $\pm$ 5°)	16° ( $\pm$ 3°)	24° ( $\pm$ 1°)

<sup>a</sup> Nominal composition based on relative amounts of HS(CH<sub>2</sub>)<sub>15</sub>CH<sub>3</sub> and HS(CH<sub>2</sub>)<sub>16</sub>OH in the ethanol solutions used to prepare the monolayers. <sup>b</sup>A single C value of 84.6 Hz/mm<sup>2</sup>, determined from the mean of the C values for the individual resonators in the first column, was used to calculate the contact angle.

**Table 3.** Comparison of contact angles measured with different methods for hexadecane drops on various organosulfur monolayer surfaces.

<u>Surface (CH<sub>3</sub>:OH)<sup>a</sup></u>	<u>QCM</u>	<u>Goniometer</u>
10:0	38° (± 1°)	42° (± 1°)
7:3	32° (± 2°)	28° (± 1°)
5:5	7° (± 1°)	4° (± 3°)

<sup>a</sup> Nominal composition based on relative amounts of HS(CH<sub>2</sub>)<sub>15</sub>CH<sub>3</sub> and HS(CH<sub>2</sub>)<sub>16</sub>OH in the ethanol solutions used to prepare the monolayers.

**Table 4.** Contact angles between aqueous sodium dodecyl sulfate (SDS) solutions (fluid 2) and various monolayers under hexadecane (fluid 1).

<u>Surface (CH<sub>3</sub>:OH)<sup>a</sup></u>	<u>0 mM SDS<sup>b</sup></u>	<u>2 mM SDS<sup>b</sup></u>	<u>5 mM SDS<sup>b</sup></u>	<u>8 mM SDS<sup>b</sup></u>
10:0	147° (148°)	142° (139°)	139° (132°)	128° (127°)
7:3	137° (135°)	133° (127°)	121° (123°)	101° (115°)
5:5	134° (128°)	128° (124°)	120° (117°)	111° (95°)
4:6	101° (93°)	86° (79°)	81° (76°)	68° (65°)
2:8	67° (62°)	41° (32°)	31.6° (26°)	23° (17°)
0:10	25° (27°)	23° (23°)	16.7° (20°)	16° (14°)

<sup>a</sup> Nominal composition based on relative amounts of HS(CH<sub>2</sub>)<sub>15</sub>CH<sub>3</sub> and HS(CH<sub>2</sub>)<sub>16</sub>OH in the ethanol solutions used to prepare the monolayers. <sup>b</sup> Values outside parentheses were measured with the QCM, inside parentheses were measured with an optical goniometry.

## Figure captions

**Figure 1.** Schematic representation of the experimental QCM apparatus for determination of contact angles and surface tensions.

**Figure 2.** (a) Schematic representation of a single fluid system covering the entire surface of the QCM. The dimension  $r_0$  extends from the center of the quartz crystal and its electrodes to the regions beyond the electrode boundaries where shear motion of the quartz crystal is negligible. (b) Schematic representation of a droplet of fluid 2 which has displaced an equal volume of fluid 1 at the center of the QCM. (c) Schematic representation of the relevant interfaces formed between the two fluid phases and the solid substrate.

**Figure 3.** Plot of  $\Delta f$  vs.  $r^2$  for determination of the constant C (eq. 17), which is used for sessile contact angle measurements with the QCM. These data were acquired on an organosulfur monolayer formed from an ethanol solution with  $[\text{HS}(\text{CH}_2)_{15}\text{CH}_3]:[\text{HS}(\text{CH}_2)_{16}\text{OH}] = 7:3$ , for which a sessile contact angle of  $90^\circ$  was measured for deionized water. The slope of this data is  $-82.1 \text{ Hz/mm}^2$ , with the goodness-of-fit of 0.999.

**Figure 4.** (a) Calculated QCM frequency changes due to differences in viscosity and density for a two-fluid system. The values were calculated for a  $2 \mu\text{L}$  water droplet (fluid 2,  $\eta_2$ ,  $\rho_2$ ) for sessile contact angles in the range  $\theta = 30^\circ - 140^\circ$ . The left side of the plot at  $\frac{\sqrt{\rho_1 \eta_1}}{\sqrt{\rho_2 \eta_2}} = 0$  is representative of the changes in  $\Delta f$  upon introduction of the water droplet to the QCM under air, whereas  $\frac{\sqrt{\rho_1 \eta_1}}{\sqrt{\rho_2 \eta_2}} = 1.20$  for introduction of the water droplet to the QCM under HD. (b) Magnification of the region in the center of (a) illustrating the small frequency shifts expected for liquids with small differences in viscosity and density. Assuming a QCM

detection limit for  $\Delta f$  of 1 Hz and the largest contact angle depicted here ( $\theta = 140^\circ$ ),  $\frac{\sqrt{\rho_1 \eta_1}}{\sqrt{\rho_2 \eta_2}}$

must be smaller than 0.95 or greater than 1.05.

**Figure 5.** (a) Dependence of the sessile contact angles on SDS concentration for a water droplet under air determined by the QCM data ( $\square$ ) and by optical goniometry ( $\blacksquare$ ). (b) Dependence of the sessile contact angles on SDS concentration for a water droplet under HD determined by the QCM data ( $\square$ ) and by optical goniometry ( $\blacksquare$ ). (c) The surface tensions ( $\gamma_{1,2}$ ) calculated from the contact angles measured with the QCM for a water droplet under HD. The data suggest a limiting value at approximately 8 mM, which is near the reported value of the CMC for SDS. This value was constant for measurements performed at SDS concentrations above 8 mM and up to 20 mM, the highest concentration examined. All data were obtained on low surface energy monolayers prepared from  $\text{HS}(\text{CH}_2)_{15}\text{CH}_3$ .

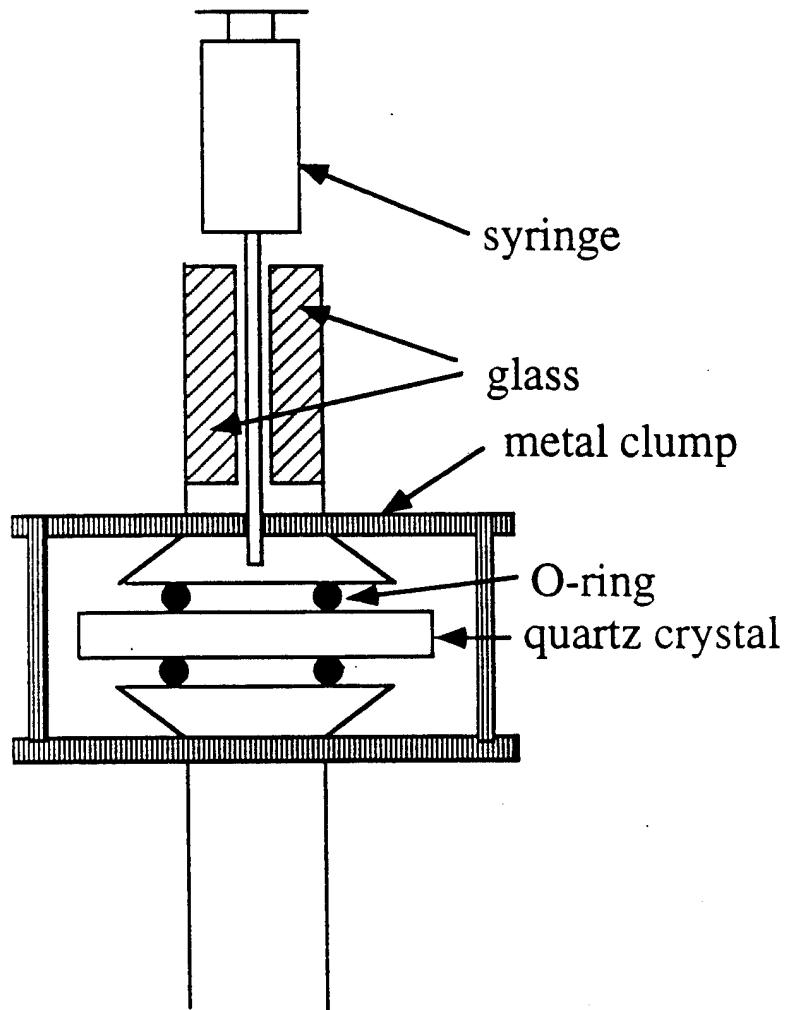

Fig 1

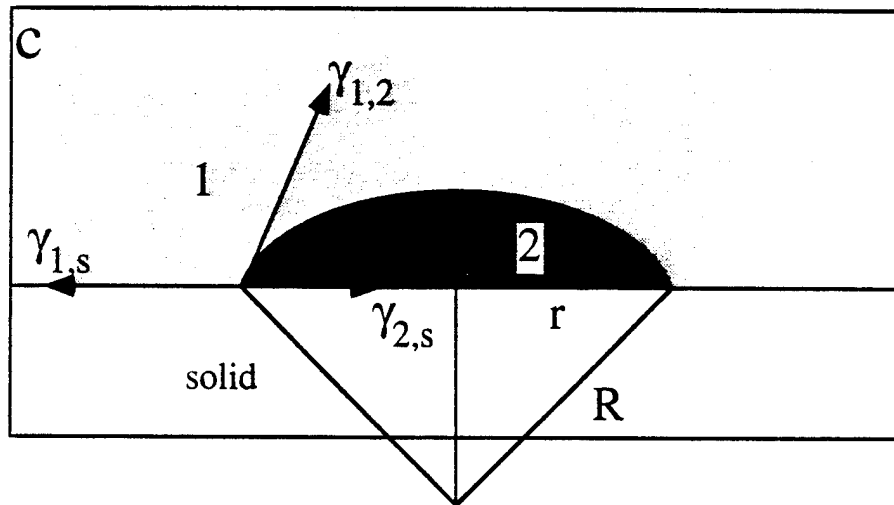
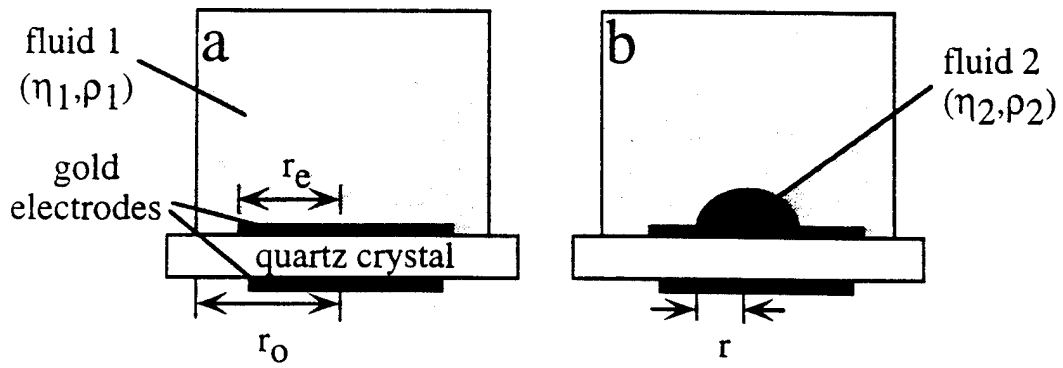

Fig 2

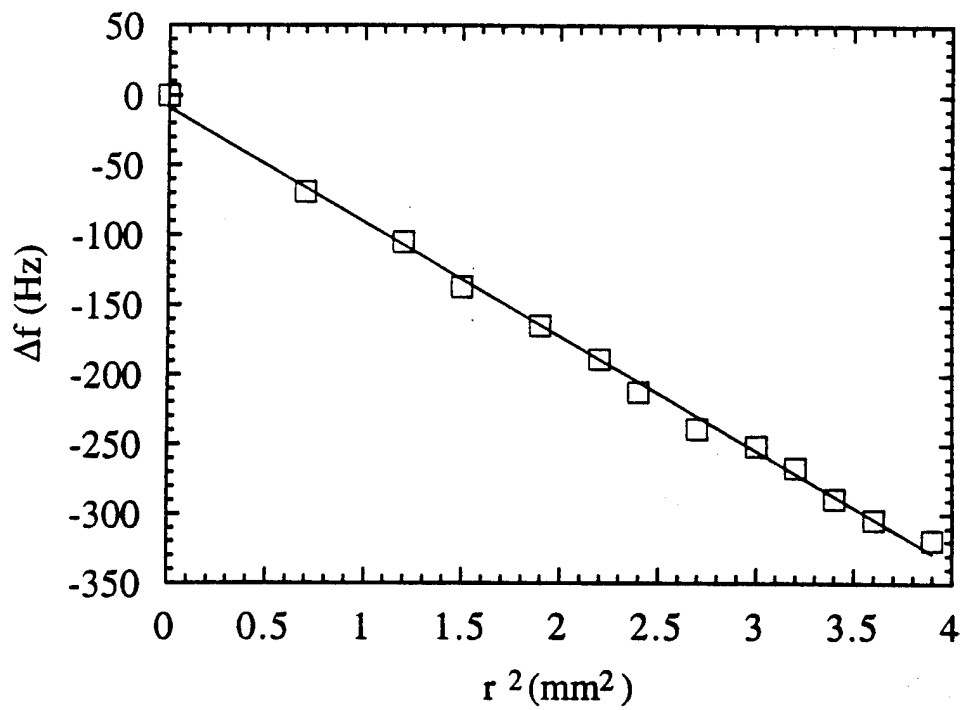

Fig 3

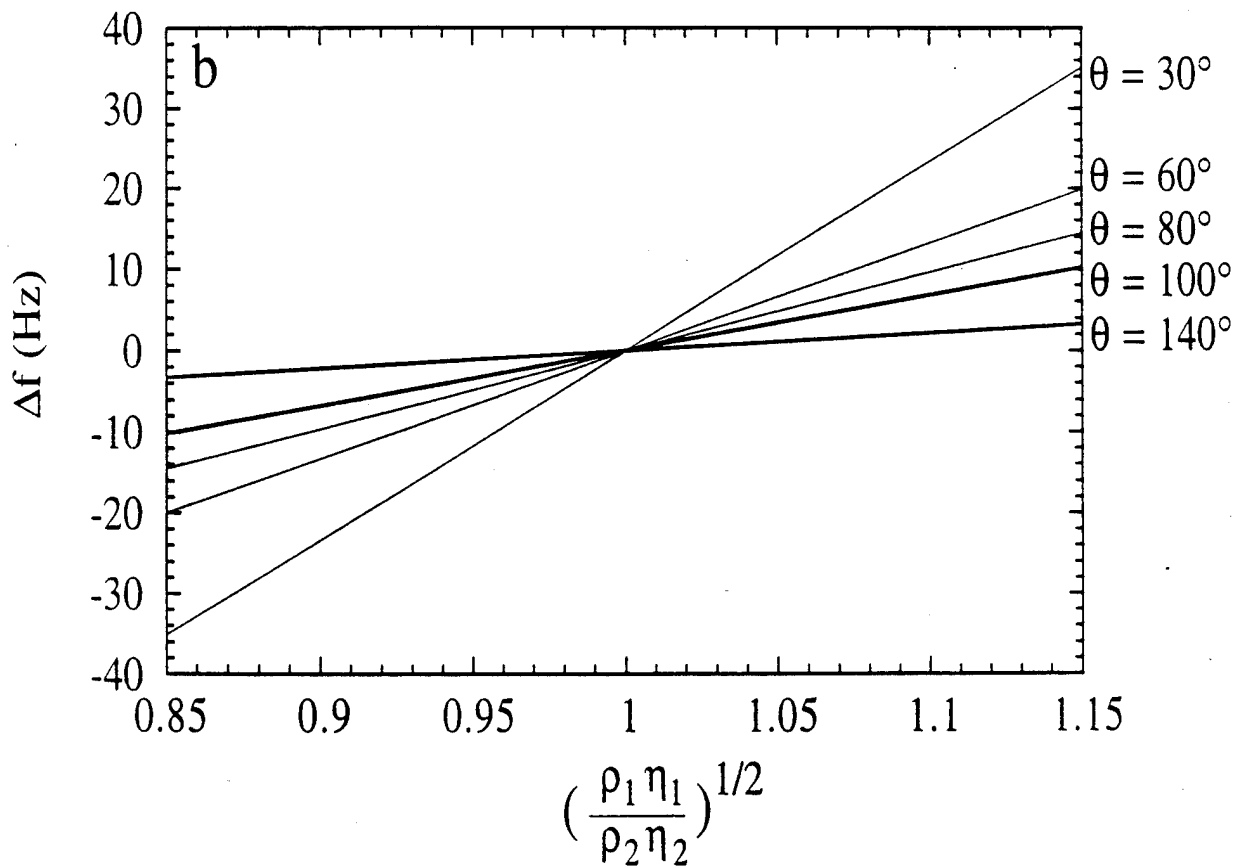
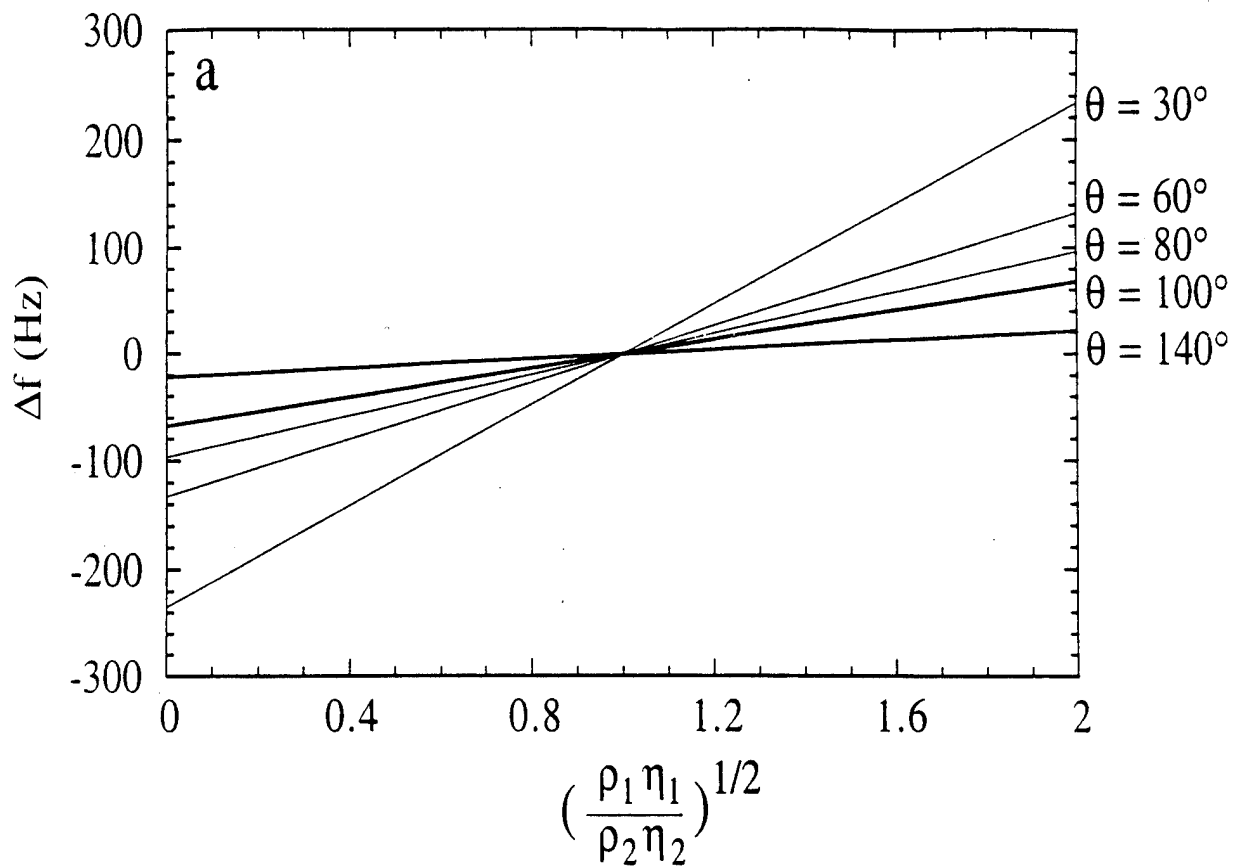

Fig 4

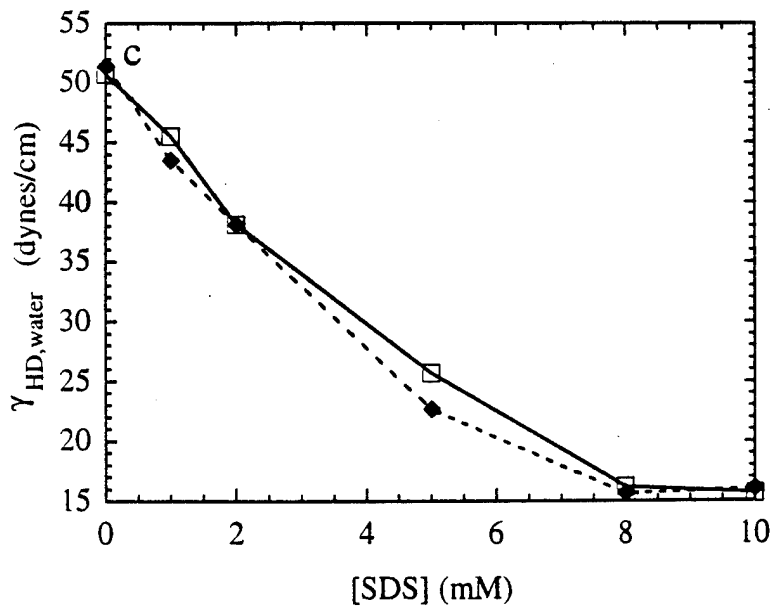
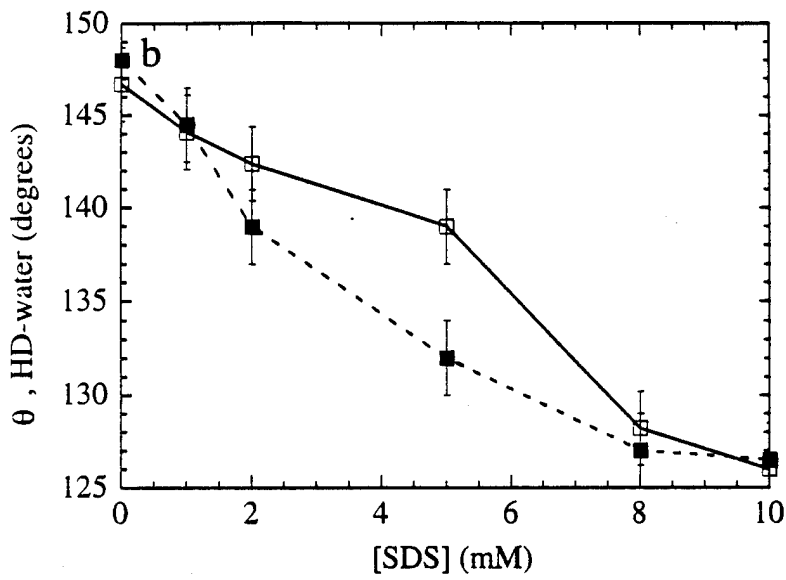
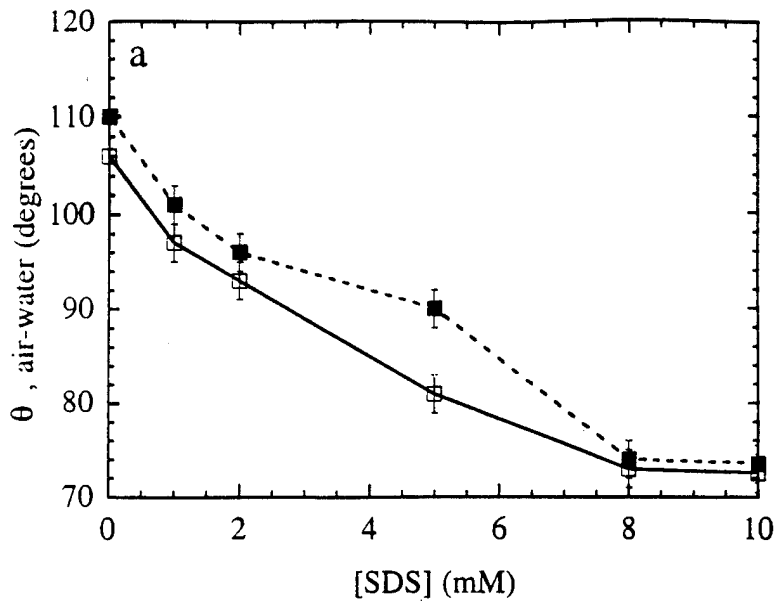

Fig 5