

NAVAL POSTGRADUATE SCHOOL MONTEREY, CALIFORNIA



THESIS

**A COST AND OPERATIONAL EFFECTIVENESS
ANALYSIS FOR FUTURE ARTILLERY SYSTEM
IN KOREA**

by

Chunsoo Kang

December, 1995

Thesis Co-Advisor:

Robert E. Ball

Thesis Co-Advisor:

William B. Colson

Approved for public release; distribution is unlimited.

19960402 150

DTIC QUALITY INSPECTED 1

DISCLAIMER NOTICE

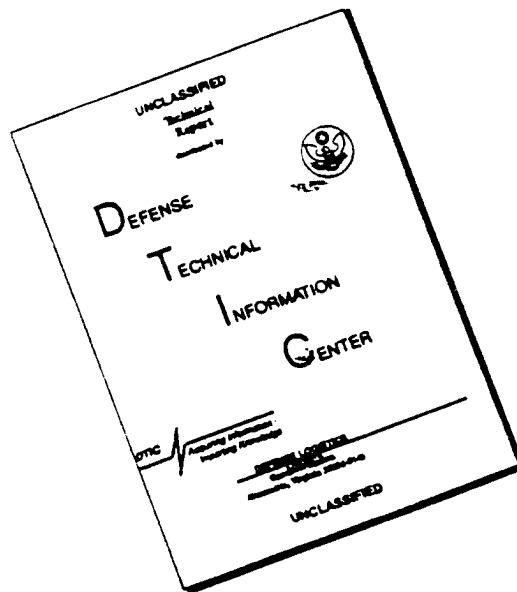

THIS DOCUMENT IS BEST QUALITY AVAILABLE. THE COPY FURNISHED TO DTIC CONTAINED A SIGNIFICANT NUMBER OF PAGES WHICH DO NOT REPRODUCE LEGIBLY.

REPORT DOCUMENTATION PAGE

Form Approved OMB No. 0704-0188

Public reporting burden for this collection of information is estimated to average 1 hour per response, including the time for reviewing instruction, searching existing data sources, gathering and maintaining the data needed, and completing and reviewing the collection of information. Send comments regarding this burden estimate or any other aspect of this collection of information, including suggestions for reducing this burden, to Washington Headquarters Services, Directorate for Information Operations and Reports, 1215 Jefferson Davis Highway, Suite 1204, Arlington, VA 22202-4302, and to the Office of Management and Budget, Paperwork Reduction Project (0704-0188) Washington DC 20503.

1. AGENCY USE ONLY <i>(Leave blank)</i>	2. REPORT DATE December 1995	3. REPORT TYPE AND DATES COVERED Master's Thesis	
4. TITLE AND SUBTITLE A COST AND OPERATIONAL EFFECTIVENESS ANALYSIS FOR FUTURE ARTILERY SYSTEM IN KOREA		5. FUNDING NUMBERS	
6. AUTHOR(S) Kang, Chunsoo		8. PERFORMING ORGANIZATION REPORT NUMBER	
7. PERFORMING ORGANIZATION NAME(S) AND ADDRESS(ES) Naval Postgraduate School Monterey CA 93943-5000		10. SPONSORING/MONITORING AGENCY REPORT NUMBER	
9. SPONSORING/MONITORING AGENCY NAME(S) AND ADDRESS(ES)		11. SUPPLEMENTARY NOTES The views expressed in this thesis are those of the author and do not reflect the official policy or position of the Department of Defense or the U.S. Government.	
12a. DISTRIBUTION/AVAILABILITY STATEMENT Approved for public release; distribution is unlimited.		12b. DISTRIBUTION CODE	
13. ABSTRACT <i>(maximum 200 words)</i> <p>The goal of the defense acquisition program is finding the most effective system with the least cost. There are two key functions to achieve this goal: measuring the effectiveness and estimating the cost of each alternative. However, the acquisition procedure of a new weapon system is very complex and uncertain, because it involves anticipating the advantages and disadvantages both friendly and adversaries currently and/or in the future. Also estimating the Life Cycle Cost requires time and huge amount of data. The U.S. Department of Defense Instruction 5000 series was prepared to show how to avoid these complexities and uncertainties, known as a Cost and Operational Effectiveness Analysis (COEA).</p> <p>The main purpose of this study is to show the COEA procedures and format by following the procedures specified in U.S. DoD Instruction 5000 series with an example of the future artillery system in Korea. As background, the concepts and terminologies of COEA and field artillery fire support are briefly examined. Following the format and procedures, the focus of this study is on the measures of the operational effectiveness of the field artillery system by using the computer simulation. The result of the simulation with different scenarios quantifies the performance characteristics and shows the relative effectiveness of each alternative.</p> <p>The other parts are also explained briefly. The acquisition issues partly covers the inferiority of military balance between South and North Korea, and estimating costs for each alternative analyzed with a short example because of the lack of data and time limit. This thesis concludes with a summary of the results so that it discriminates and ranks each alternative.</p>			
14. SUBJECT TERMS Cost and Operational Effectiveness Analysis, Field Artillery, DoD Instruction 5000 series, Projectile Motion, Model, Random Number, Target, Damage, Simulation, Hit Distribution, Life Cycle Cost, Cost Estimation		15. NUMBER OF PAGES 115	
		16. PRICE CODE	
17. SECURITY CLASSIFICATION OF REPORT Unclassified	18. SECURITY CLASSIFICATION OF THIS PAGE Unclassified	19. SECURITY CLASSIFICATION OF ABSTRACT Unclassified	20. LIMITATION OF ABSTRACT UL

Approved for public release; distribution is unlimited.

A COST AND OPERATIONAL EFFECTIVENESS ANALYSIS
FOR FUTURE ARTILLERY SYSTEM IN KOREA

by

Chunsoo Kang
Major, R.O.K. Army
B.S., Korea Military Academy, 1985

Submitted in partial fulfillment
of the requirements for the degree of

MASTER OF SCIENCE IN APPLIED PHYSICS

from the

NAVAL POSTGRADUATE SCHOOL
December 1995

Author:



Chunsoo Kang

Approved by:



Robert E. Ball, Thesis Co-Advisor



William B. Colson, Thesis Co-Advisor

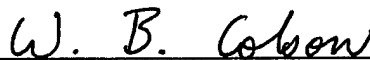

William B. Colson, Chairman
Department of Physics

ABSTRACT

The goal of the defense acquisition program is finding the most effective system with the least cost. There are two key functions to achieve this goal: measuring the effectiveness and estimating the cost of each alternative. However, the acquisition procedure of a new weapon system is very complex and uncertain, because it involves anticipating the advantages and disadvantages both friendly and adversaries currently and/or in the future. Also estimating the Life Cycle Cost requires time and huge amount of data. The U.S. Department of Defense Instruction 5000 series was prepared to show how to avoid these complexities and uncertainties, known as a Cost and Operational Effectiveness Analysis (COEA).

The main purpose of this study is to show the COEA procedures and format by following the procedures specified in U.S. DoD Instruction 5000 series with an example of the future artillery system in Korea. As background, the concepts and terminologies of COEA and field artillery fire support are briefly examined. Following the format and procedures, the focus of this study is on the measures of the operational effectiveness of the field artillery system by using the computer simulation. The result of the simulation with different scenarios quantifies the performance characteristics and shows the relative effectiveness of each alternative.

The other parts are also explained briefly. The acquisition issues partly covers the inferiority of military balance between South and North Korea, and estimating costs for each alternative analyzed with a short example because of the lack of data and time limit. This thesis concludes with a summary of the results so that it discriminates and ranks each alternative.

TABLE OF CONTENTS

I. INTRODUCTION.....	1
A. GENERAL.....	1
B. ORGANIZATION OF THESIS.....	2
II. BACKGROUND.....	3
A. DEFENSE ACQUISITION PROCESS AND PROCEDURES.....	3
B. COST AND OPERATIONAL EFFECTIVENESS ANALYSIS (COEA).....	4
C. FIELD ARTILLERY FIRE SUPPORT.....	6
1. Mission.....	6
2. Organization.....	6
3. Weapon System.....	7
4. Fire Support.....	8
a. Gunnery Team.....	8
b. Fire Support Procedures.....	8
5. Future Artillery.....	9
a. Overview.....	9
b. U.S. Army.....	9
c. Germany.....	10
d. The Other Countries.....	10
III. ACQUISITION ISSUES.....	11
A. NEED.....	11
1. Total Strength of Forces in The South and North.....	11
2. Artillery.....	12
B. THREAT.....	13
1. Current Situation of North Korean Military.....	13
2. Military Strategy of North Korea.....	13
C. OPERATIONAL ENVIRONMENT.....	13
D. CONSTRAINTS.....	14
1. Defense Budget.....	14
2. Composition of Defense Budget.....	15
3. The Future.....	16

E. OPERATIONAL CONCEPTS.....	16
IV. ALTERNATIVES.....	17
A. PERFORMANCE OBJECTIVES.....	17
B. DESCRIPTION OF THE ALTERNATIVES.....	18
1. Home Development or Modification.....	18
2. Import from Other Countries.....	21
V. ANALYSES OF ALTERNATIVES.....	25
A. ARTILLERY MODEL.....	25
1. Projectile Motion with Gravity and Drag Force.....	26
2. Hit Distribution and Random Numbers.....	29
3. Target Descriptions and Assumptions.....	32
B. MEASURES AND ANALYSES OF EFFECTIVENESS.....	34
1. Rate of fire.....	35
2. Response Time.....	43
C. COSTS.....	43
D. TRADE-OFF ANALYSES.....	49
E. DECISION CRITERIA.....	50
VI. SUMMARY OF THE RESULTS.....	53
VII. CONCLUSIONS.....	55
APPENDIX A. COEA FORMAT.....	57
APPENDIX B. 'C' PROGRAM FOR THE PROJECTILE TRAJECTORY.....	61
APPENDIX C. TRAJECTORY PLOT.....	63
APPENDIX D. 'C' PROGRAM FOR THE CHECKING PROBABLE ERRORS.....	65
APPENDIX E. PROBABLE ERRORS VERSUS ROUNDS FIRED.....	69
APPENDIX F. PROBABLE ERRORS WITH VELOCITY AND ANGLE CHANGES.....	71
APPENDIX G. SAMPLE PLOT OF HIT DISTRIBUTION.....	77

APPENDIX H. 'C' PROGRAM FOR MULTIPLE FIRING AGAINST AREA TARGETS.....79

APPENDIX I. AVERAGE DAMAGE VERSUS NUMBER OF EXPERIMENT.....85

APPENDIX J. SAMPLE OUTPUT OF THE MOVING TARGET.....87

LIST OF REFERENCES.....93

BIBLIOGRAPHY.....95

INITIAL DISTRIBUTION LIST.....97

LIST OF FIGURES

2-1. Defense Acquisition Milestones and Phase.....	3
5-1. Flow of the Model.....	25
5-2. Coordinate System for the Model.....	26
5-3. Plot Air Density against Height.....	28
5-4. Uniform Distribution.....	29
5-5. Continuous Probability Distribution Function.....	30
5-6. Target Size and Aiming Points.....	33
5-7. Dispersing Target with Speed 50 m/min.....	36
5-8. Cumulative Damage after Six Rounds with Different Rate of Fire.....	38
5-9. Relative Effectiveness of the Different Systems to Dispersing Target.....	39
5-10. Cumulative Damage with Different Target Speed.....	40
5-11. Relative Effectiveness of the Different Systems to Linearly Moving Target.....	42
5-12. Relationship and Composition of the Standard Costs.....	44
5-13. Estimate of the M109A6 Unit Cost.....	48
5-14. Cost Difference among the Alternatives.....	51

LIST OF TABLES

3-1. Military Forces of South and North Korea.....	11
3-2. Artillery Composition of South and North Korea.....	12
3-3. Comparison of Defense Budget.....	15
3-4. Composition of the Defense Budget in each Fiscal Year.....	15
4-1. Specifications of the 130 mm MRL.....	19
4-2. Specifications of the Howitzers of the Korean Army.....	20
4-3. Comparison of Some Systems.....	21
4-4. Specifications of the MLRS.....	22
5-1. Air density at the different altitude.....	27
5-2. Cumulative Damage to a Stationary Target.....	34
5-3. Target Size and Cumulative Damage for 1 round/min.....	37
5-4. Target Size and Cumulative Damage for 4 rounds/min.....	37
5-5. Target Size and Cumulative Damage for 10 rounds/min.....	37
5-6. Cumulative Damage by 1 round/min.....	41
5-7. Cumulative Damage by 4 rounds/min.....	41
5-8. Cumulative Damage for 10 rounds/min.....	41
5-9. R & D Cost of the U. S. Army Artillery Systems (in million dollars).....	46
5-10. M109A6 Cost Data (\$ in million).....	47
6-1. Summary of the Results.....	53

ACKNOWLEDGMENT

An ancient Confucianism book said that one of the joys of life is learning new things and practicing it occasionally. Unfortunately, I've never intended to devote myself to study with any joy before I came here. Up to high school, I ran between home and school in order to go to a university, as the other teenagers do. After graduating from the military academy, I never imagined studying for a higher degree.

After many turns and twists, I arrived at the most wonderful place where I learned with much more joy than before. I realized the value and pleasure of learning as mentioned in an ancient book. Various opportunities to learn, to do research, to travel, etc., were open to me. Not only in the classroom, but also at all the other places I tried to focus all my studies and experiences on the military view point.

Now, I am close to finishing my special experience here and have to prepare to return to my native country where I will devote myself to practice and utilize of what I learned and experienced during this unforgettable time.

I appreciate the Korean Army giving me such a great chance to study and experience new things, special thanks to Col. Park, S., Lt. Choi, C., and Lt. Jung, K. who recommended to this course and/or taught me what to do as an officer. I'd like to also express my heartfelt thanks to my advisors, Professor Robert E. Ball and Professor William B. Colson, for guidance, kind consideration and extra work caused by my English and to both parents, parents-in-laws, and other family members for supporting me both morally and physically during my stay. Above all to my lovely wife, I hope my completion of this course can be partial compensation for devoting herself to support of my study and to raise children instead of getting a Ph. D. degree.

At the closing point of the NPS time,

KANG, CHUNSOO

Major, Korean Army

I. INTRODUCTION

A. GENERAL

The acquisition of a modern weapon system may require a significant proportion of a defense budget and may take many years to accomplish. Furthermore, measurement of the effectiveness of the system is always difficult (or impossible) without actually using the system in war. Therefore, the management of a defense acquisition program is one of the major issues in all countries.

Traditionally, defense acquisition management policies and procedures have been published in numerous directives and instructions. This has resulted in a heavily cross-referenced maze of guidance that has stifled creativity and defied practical use. To solve this problem, the U.S. Department of Defense (DoD) established a core of fundamental defense acquisition policies and procedures, known as DoD instruction 5000 series in February, 1991. This series of publication categorizes acquisition and defines the functions and responsibilities of each program manager and related government officials at each step of the program. It also requires a Cost and Operational Effectiveness Analysis (COEA) for all new acquisition programs.

The key point of a COEA is measuring or estimating operational effectiveness which can be done by either field tests or analytical approach. However, field test takes a lot of time and money. Some kinds of tests, especially for lethal weapons, are very dangerous, or even impossible. Furthermore, environmental contamination caused by a weapon firing test is one of world-wide issue. As a result, much of the effectiveness evaluation is done analytically. But the analytical evaluation of the weapon system is less realistic and less confident. Therefore, U.S. DoD set up the minimum requirement of field test, known as live fire test law.

Application of modern computer technology enables us to evaluate the operational effectiveness more realistically and more confidently. Various combat situation can be modeled with computer simulation with less cost, time, danger, and other undesirable side effects.

B. ORGANIZATION OF THESIS

This thesis will present the procedures of a COEA and give an example of operational effectiveness measurement of field artillery fire support by using computer simulation.

Chapter II contains background information of the COEA and terminologies of field artillery fire support concepts related to this thesis. Readers having this background may skip this chapter. Most of this chapter consists of explanations of terminologies, acronyms, and abbreviations in accordance with current field artillery manuals (mainly FM 6-20, 6-30, 6-40) and DoD instruction 5000 series.

Chapters III to V follow the COEA format specified in DoD instruction 5000 series and attached in Appendix A. Chapter III covers the acquisition issue related to new artillery system for the Republic of Korea (ROK) Army. The acquisition issues start from the needs of the system, the threat analysis, constraints, and operational concepts of the system.

Chapter IV presents the proposed performance objectives and possible courses of action or alternatives to satisfy the acquisition issues. As an example, several 155 mm Howitzers, 130 mm Multiple Rocket Launcher, and 227 mm Multiple Launch Rocket System are presented in detail.

The core of this thesis is Chapter V, which contains the modeling and simulation of artillery fire. Effectiveness against different artillery system performances are modeled and measured by simulation.

This thesis concludes with the results of analyzing alternatives. But some costs in this thesis are not the real data because most data are classified. Therefore, these results are only examples and there should be more thoroughly studied with real data for the actual use.

II. BACKGROUND

A. DEFENSE ACQUISITION PROCESS AND PROCEDURES

DoD instruction 5000 series defines the acquisition process as illustrated in Figure 2-1.

[Refer DoD Instruction 5000.2, p.3-4].

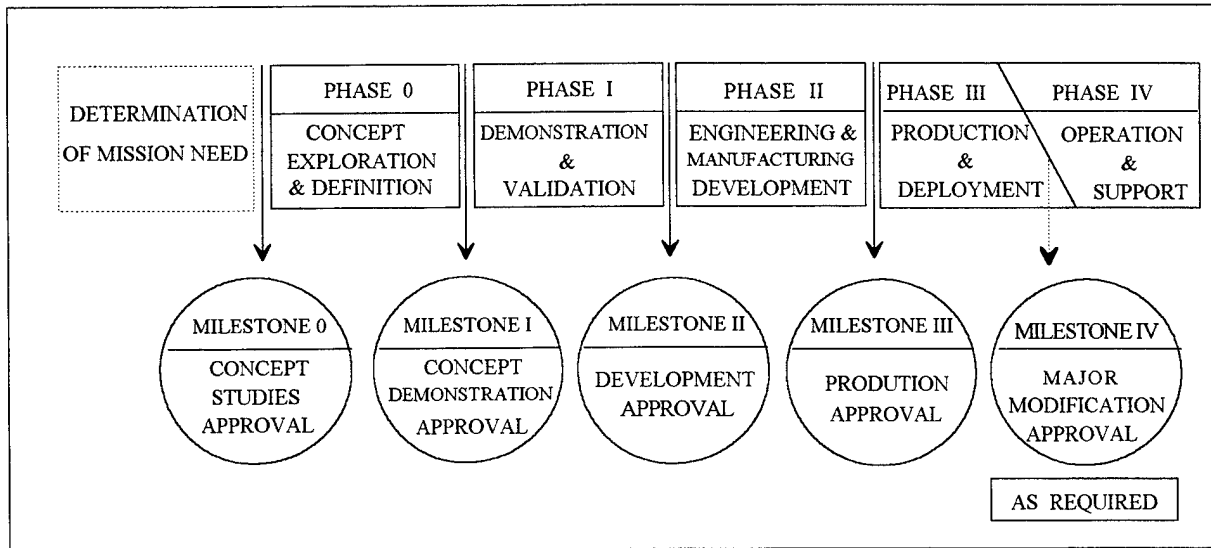

Figure 2-1. Defense Acquisition Milestones and Phase

(Source : DoD instruction 5000.2 p.3-4)

All acquisition programs start with identification of new mission need. Any level of command, military departments, or the Joint Staff may identify mission needs, or new operational capabilities. If there is no non-material solution, such as changes in doctrine, operational concepts, tactics, training, organization, and so on, the mission needs will be expressed in terms of an operational capability, which is called Mission Need Statement (MNS). Mission Need Statements that could potentially result in the initiation of a new acquisition program will be sent to the appropriate DoD component for action. Major actions or objectives at each stage will be listed below.

Milestone 0, Concept Studies Approval, is a decision point whether studies of alternative concepts could satisfy the identified mission need.

Once concepts are approved, the acquisition program starts at Phase 0, where more studies analyze alternatives and the most promising system concepts will be defined.

Milestone I, Concept Demonstration Approval, is the first direct interaction point between the planning, programming, budgeting and acquisition management systems, for which decision authorities must assess affordability of the proposed new acquisition program.

Phase I, Demonstration and Validation: Multiple design approaches and parallel technologies are pursued within the system concept(s) during this phase.

Milestone II, Development Approval, is a decision point whether the results of Phase I warrant continuation and establishing a development baseline containing refined program cost, schedule, and performance objectives for a program approved for continuation.

Phase II, Engineering & Manufacturing Development: Effective risk management is especially critical during this phase.

Milestone III, Production Approval: A favorable decision at this point represents a commitment to build, deploy, and support the system.

Phase III, Production & Deployment: System performance and quality will be monitored by follow-on operational test and evaluation during this phase.

Milestone IV, Major Modification Approval: The intent of this milestone is to ensure that all reasonable alternatives are thoroughly examined prior to committing to a major modification or upgrade program for a system that is still being produced.

Phase IV, Operation & Support, is overlapping with Phase III. The objectives of this phase are to ensure that the fielded system continues to provide the capabilities required to meet the identified mission need and to identify shortcomings or deficiencies that must be corrected to improve the performance.

B. COST AND OPERATIONAL EFFECTIVENESS ANALYSIS

Cost and operational effectiveness analysis is an essential part of the decision making process for all defense acquisition programs. The definition of the COEA is well described in Part 8, DoD Instruction 5000.2-M. "A cost and operational effectiveness analysis evaluates the costs and benefits (i.e., the operational effectiveness or military utility) of alternative courses of action to meet recognized defense needs."

A COEA has three main purposes: (1) to aid in decision making, (2) to facilitate communications, and (3) to document the acquisition decision. It shows the relative advantages and disadvantages of the alternatives and the sensitivity of each alternatives against changes of key assumptions and/or variables. It facilitates discussion about the acquisition program among the related authorities, service principals and other staffs, especially at the early stages of the procedures. It provides analytical assessment and a historical record for decisions on an acquisition program.

The Procedures of a COEA are: (1) the acquisition issue, (2) the alternatives, (3) the analysis of the alternatives, and (4) summary of the results. Part 8, DoD Instruction 5000.2-M describes in detail the procedures and elements of the COEA which are Chapters III to VI of this thesis.

The following are definitions and acronyms that apply to this thesis in accordance with defense acquisition manuals and instructions.

LCC (Life Cycle Cost) is the total cost to the government of acquisition and ownership of the system over its useful life, including the cost of development, acquisition, support and disposal where applicable.

MTBM (Mean Time Between Maintenance) is the total functional life of a population of an item divided by the total number of maintenance actions for a particular interval (basic technical estimate of the maintenance frequency).

MTTR (Mean Time To Repair) is the total elapsed time (clock hours) for corrective maintenance divided by the total number of corrective maintenance actions during a given period of time (basic technical measurement of maintainability).

MTBF (Meantime Between Failure) is the total functional life of a population of an item divided by the total number of failures for a particular interval (basic technical measurement of reliability).

R & D : Research and Development

C. FIELD ARTILLERY FIRE SUPPORT

1. Mission

Fire support is the dominant part of the modern battlefield. Field artillery (FA) is known as the "King of Battle," because of its ability to inflict massive damage on enemy forces. Field artillery has the responsibility of integrating all fire support resources, such as cannon, rocket and missile fire into the air-land battle.

The mission of field artillery is described in the both U.S. and Republic of Korea Army field manual (FM) 6-20: "to destroy, neutralize, or suppress the enemy by cannon, rocket, and missile fire and to help integrate all fire support assets into combined arms operation." To accomplish this mission in the combat situation, each field artillery (FA) unit (usually a battalion) is assigned one of any of the following tactical missions.

DS (Direct Support) : In most tactical situations, one FA battalion is assigned to one maneuver brigade with a direct support mission. This battalion is primarily concerned with the fire support needs of that maneuver unit.

R (Reinforcing) : This tactical mission causes one FA battalion to augment the fires of another FA battalion.

GS (General Support) : A battalion assigned the mission of general support supports the force as a whole and stays under the immediate control of the force artillery headquarters.

GSR (General Support Reinforcing) : The GSR mission requires the FA battalion to furnish artillery fires for the forces as a whole and to reinforce the fires of another FA battalion as a second priority.

2. Organization

The organization of field artillery at different echelons is dependent upon the type of tactical mission. As a minimum firing unit, the 155 mm self-propelled field artillery battery organic to division artillery consists of a battery headquarters, a battery Fire Direction Center (FDC), several howitzer sections, and the associated service support. The U.S. Army battery has 8 guns, but the Korean Army battery has 6 guns. In this thesis, a six howitzer battery is used as a sample firing unit.

The echelon above the battery is the battalion. The normal field artillery firing battalion consists of a battalion headquarters, a battalion FDC, three howitzer batteries, a Fire Support Element (FSE) for the maneuver brigade and associated service support.

The level above the battalion is the division artillery (DIVARTY), or corps artillery or field artillery brigade. A DIVARTY ordinarily consists of a DIVARTY headquarters, a DIVARTY FDC, four howitzer battalions, one target acquisition battery, FSE for division, and associated service support. The composition of corps artillery and artillery brigade varies with unit mission and type.

3. Weapon System

The focus on the field artillery weapon system in this thesis is the firing mechanism (i.e. mainly concerned with delivering equipment, projectile and fuze). The following are acronyms, abbreviations, and terminologies used in the thesis.

ATACMS : Army Tactical Missile System

BN : Battalion

FA : Field Artillery

MLRS : Multiple Launch Rocket System

MRL : Multiple Rocket Launcher

SP : Self Propelled

HE : High Explosive

HEAT : High Explosive Anti-tank

ILL : Illumination

WP : White Phosphorus

ICM : Improved Conventional Munitions

 APICM : Anti-personnel ICM

 DPICM : Dual Purpose (against personnel and armor) ICM

FASCAM : Family of Scatterable Mines

RAP : Rocket Assisted Projectile

SADARM : Sense and Destroy Armor

Q : Quick

VT : Variable Time (Proximity Fuze)

TI : Time

Round : Complete parts that make up the ammunition necessary to fire. It consists of a primer, a propelling charge, a projectile, and a fuze.

Volley : unit of firing at one fire mission and a certain type of ammunition at the designated target. For example, if each howitzer in a unit fires 4-rounds of high explosive ammunition at a particular target, this is called as 4-volleys of high explosive.

Probable error : The measurement of the impact distribution in the dispersion pattern around the mean point of impact. Field Artillery uses deflection probable error and range probable error.

Deflection probable error : The directional error caused by dispersion in a single deflection.

Range probable error : The range error caused by dispersion in a single elevation.

4. Fire Support

a. Gunnery Team

In order to accomplish its mission, the field artillery relies on the fire support gunnery team. The team consists of an observer, the fire direction center, and the firing unit.

The observer serves as the "eyes" of the fire support gunnery team. Detecting and locating suitable indirect fire targets are the major responsibilities of the observer. The observer may be a soldier with binoculars, a radar section with a sophisticated radar system, a Fire Support Team (FIST), or any other source for detecting and/or locating the target.

The FDC serves as the "brains" of the fire support gunnery team. The FDC receives the requests for fire from an observer and converts it to firing data and then to fire commands for the howitzers.

The firing unit acts as the "brawn" of the gunnery team. At the firing unit level the howitzer crew sets the firing data off on the weapon and fires the round.

b. Fire Support Procedures

A routine request for field artillery fire support consists of the following events. Once a forward observer (FO) detects the target, the target information is transmitted to the FDC through fire support coordination. When the target data reaches a FDC, a fire direction officer (FDO) determines whether the target can be engaged by his unit. If his unit will engage the target,

the FDO determines the amount and type of ammunition with which to engage the target. The target location is converted into firing data and fire commands are sent to the howitzers, where the ammunition is loaded and the weapon is fired.

A firing unit can attack the target by either adjust-fire or fire-for-effect. Adjust-fire is a term describing a method of control transmitted in the call for fire by the observer or spotter to indicate that he will control the adjustment which is the process of correcting the impact location of the round, with one gun firing one round at a time, until the desired location is achieved.

Fire-for-effect is the fire that is intended to achieve a desired effect on the target. If "fire-for-effect" is requested at the beginning of fire mission, that means fire-for-effect without adjustment. This can achieve maximum surprise but accuracy of target location and other non-standard corrections are more critical than in the adjust fire mission.

5. Future Artillery

a. Overview

Every country tries to make a better artillery systems with various kinds approach. However, there are several common considerations for those systems. Those were well presented at the 4th International Cannon and Artillery Firepower Symposium and Exhibition in June 19-22, 1995.

The most important consideration is the range. With modern weapon technology, the depth of battle increased significantly. It is getting hard to distinguish between the frontal and rear area in the modern battlefields.

The next consideration is survivability. To increase survivability, the crew remains in the protected vehicle throughout the mission. Some systems have Nuclear, Biological, and Chemical (NBC) protective equipment.

Enemy forces are also equipped with a lot of high mobility vehicles. That means most targets are not a stationary target and a system with the shorter response time can more effectively attack the targets.

b. U.S. Army

The intent of the U.S. Army field artillery was described by Brigadier General Leo Baxter, Assistant commandant of the U.S. Army field artillery school, at the 4th International

Cannon and Artillery Firepower Symposium and Exhibition in June 19-22, 1995. He said "There will be four major field artillery weapon systems; 105 mm towed for the light infantry, 155 mm SP and towed as a medium and main system, and Rocket Launchers."

The U.S. Army is currently replacing its main artillery weapon system, M109A2/A3 to M109A6 (PALADIN) and developing new system known as a CRUSADER.

c. Germany

The German Army is developing future artillery system, called the SP 2000 program. The howitzer of this program is named as PzH 2000 (Panzerhaubitze 2000), 155 mm SP with maximum range 30 and 40 km depending on the ammunition used. It was accepted in 1995 with series production starting the following year, and will be deployed in 1998.

d. The Other Countries

Most countries have programs for developing or buying new artillery system individually or conjointly. France has similar program called CAESAR, 155 mm Towed, the British Army has the AS90 mid-life Improvement program to develop a new 155 mm and the Modular Charge System (MCS). The CAESAR system has been developed as a private venture aimed at the export market and it was shown in public for the first time in June 1994.

The comparison of more detailed characteristics of the systems mentioned above and the current system, M109A2/A3, will be shown on the Table 4-3.

III. ACQUISITION ISSUES

A. NEED

This element of the COEA describes identified deficiencies of the existing system and presents alternatives for satisfying the needs at Milestone 0, Concept Studies Approval in the Mission Need Statement (MNS).

1. Total Strength of Forces in the South and North

The Korean peninsula has one of the highest density of military force in the world. More than one and half million active military forces face each other along the 155 miles of armistice line between South and North Korea.

The composition of each side is shown in the Table 3-1.

Table 3-1. Military Forces of South and North Korea

Classification		South	North
Troops	Army	540,000	900,000
	Navy	60,000	46,000
	Air Force	55,000	84,000
	Total	655,000*	1,030,000**
Number of Units	Corps	11	18
	Division	50***	53
	Brigade	21	99
Equipment	Tanks	1,950	3,800
	Armored	2,100	2,500
	Field Artillery	4,600	10,800

* Excluding those enlisted for defense call-up and including Marine Corps within the Navy

** Marine Corps troops that are organized into the Army are included in the Army

*** Including Marine Corps divisions

(Source : Defense White Paper 1994-1995, p.80)

South Korean Forces are augmented by United Nation (U.N.) Forces, mainly composed of U.S. Forces (a Army Headquarters, a infantry division, and some combat support units). This is barely enough in number to defend against North Korea's more than one million troops. In major equipment, North Korea has much a greater number of tanks, armored vehicles, and field artillery weapons.

2. Artillery

The biggest inferiority is in the number of field artillery weapons. Table 3-2 shows the composition of the major field artillery weapon systems of South and North Korea.

Table 3-2. Artillery Composition of South and North Korea

Classification	South		North	
	Number	Type (mm)	Number	Type (mm)
Howitzer, Gun	4,500	105,155 175 8"	8,200	76.2, 100, 122,130, 152,160
MRL	100	130	2,600	107, 122, 132, 240

(Source : Defense White Paper 1994-1995, p.60 and p.80)

The table shows that the North Korean artillery has many weapon types, which may cause logistic problems because they imported most weapon systems in a desultory way to be superior than South Korea. Also, they have many more Multiple Rocket Launchers (MRLs) compared to the number of artillery pieces. North Korea also has many more mortars and tactical missiles which were not listed on the table.

The U.S. Army in Korea also has a DIVARTY: one 155 mm SP BN, one 155 mm Towed BN, one MLRS BN, and one target acquisition battery. However, there is still a large gap in the fire support capabilities that might sway the result of a conflict. There are several possible alternatives to compensate for the inferiority of the fire support capability of the South. Chapter IV will describe the alternatives, and Chapter V will analyze the alternatives based on the result of computer simulations.

B. THREAT

This is the analysis that determines those elements against which a given system might be used and the forces that could be used against that system. This analysis also presents projected enemy forces including tactics and countermeasures with a reasonable degree of assurance.

1. Current Situation of North Korea

Currently North Korea faces fatal economic difficulties, such as chronic food shortage, energy shortage, and so on, caused by closed policy on the basis of its self-reliance and centrally controlled economy.

Despite serious economic difficulties, North Korea has dashed forward to buildup armaments quantitatively and qualitatively. However, after the collapse of the Soviet Union and European communist countries, North Korea realized that they also face a critical crisis stage to maintain their unique system. To survive under the unfavorable international security situation, they are trying to develop nuclear weapons. But this also causes close world-wide observation and more isolation.

Their political situation is unstable after the most notorious dictator Kim, Ilsung died last year. They may open fire on the South to find the solution of their complex international problems and interior discontent.

2. Military Strategy of North Korea

The North Korean Military structure is a mixed imitation of those of the former Soviet Union and China. Under control of the Defense Committee, the highest military authority, Ministry of the People's Armed Forces (MPAF) has the single command system with general staff.

Most of their units are deployed in a frontal area with an attack formation so that they can attack without any major change of position. This makes it hard to detect their intent of starting a war. Their artillery units, covered in trenches or underground bases, are capable of deep fire support without exposure. They can also deliver concentrated and massive fire with the Multiple Rocket Launchers.

C. OPERATIONAL ENVIRONMENT

This part of the COEA describes all the natural operational environmental evaluations, such as terrain, weather, altitude, etc., and the potential allied forces contributions including the

concepts of operation, projected force structure and capabilities, and the operational threat environment and survivability requirements. This thesis does not specify these in detail because it is focused on the operational effectiveness, but will mention the contents briefly.

A dominant characteristic of field artillery comparing to the other delivery systems is that it can provide fire support under all weather conditions and in all types of terrain. Some of the artillery systems in some countries can accomplish special missions. For example, the U.S. Army has several light 105 mm towed howitzers for air assault forces.

To accomplish fire support missions at all times, the artillery system needs survivability and/or reliability requirements in terms of the various kinds of natural conditions and induced conditions both operationally and non-operationally.

Operational natural environments describe natural conditions in which the system operates properly, such as temperature, heat, humidity, altitude, pressure, elevation, wind, sand or dust, precipitation, and so on. Non-operational natural environments specify the requirements during the storage and transportation, including the storage temperature and humidity, and the transportation elevation. Induced operational environments cover the influences of shock and vibration caused by road march or shipping and handling, and overpressure caused by gun firing, etc. Non-operational induced environments describe all the other conditions for cleaning, transportation, assembly or disassembly, and so on.

D. CONSTRAINTS

Constraints and/or assumptions are factors that limit the alternatives. Personnel, funding, and technical constraints should also be considered. The defense budget is considered as a major constraint in this thesis.

1. Defense Budget

South Korea has developed remarkably since the armistice of the Korean war in 1953, while spending a lot of money to ensure national security against North Korea who exerted themselves building up military superiority. However, the portion of the defense budget tends to be limited by the social budget requirements. Table 3-3 shows the proportion of the defense budget compared to the Gross National Product (GNP) and the total government budget.

Table 3-3. Comparison of Defense Budget

Classification	1989	1990	1991	1992	1993	1994
% of GNP	4.7	4.4	4.0	3.6	3.5	3.5
% of total budget	31.3	29.3	27.6	25.1	24.2	23.3

* Based on the finalized budget

(Source : Defense White Paper 1994-1995, p.224)

2. Composition of Defense Budget

Due to the sensitive security situation, the detailed contents of defense budget of the current fiscal year can't be dealt with here, but Table 3-4 shows the composition of the defense budget for recent five fiscal years.

Table 3-4. Composition of the Defense Budget in each Fiscal Year

Classification	1989	1990	1991	1992	1993	1994
Total	100	100	100	100	100	100
Force Improvement	38.1	36.8	34.8	33.0	31.6	30.2
Force Operation	38.0	40.1	42.4	44.1	45.0	45.7
Equipment Support	11.4	10.2	9.9	9.6	9.4	9.3
Facility Maintenance	13.7	13.2	13.2	13.3	14.0	14.8

(Source : Defense White Paper 1994-1995, p.224)

With the given defense budget, investment for the new military capability decreases relative to the increasing the cost of operating the military forces, including better working conditions and living standards.

Furthermore, within the framework of the defense budget, the South must spend a lot of the budget replacing the reduced U.S. forces as they pursue their reduction and role change rather than spending for advanced weapon systems.

For example, in 1994 the total defense budget was 11,339 Billion (B) won (or about \$ 14.0 B), but the expenditure for the force improvement was only 3,039.6 B won (or about \$3.76 B).

3. The Future

The Budget for the artillery forces can't be clearly identified, but it is around five percent of the Force Improvement budget. (i.e. 150 B won or about \$ 0.19 B in 1994). As operation and support costs increase, due to higher labor and welfare requirements, the Force Improvement budget will be continuously decreased over the next several years. Also, advanced technical weapon systems require more funds, so that the artillery improvement budget will be around 150 B won (or about \$ 0.2 B) in 1994 currency.

E. OPERATIONAL CONCEPTS

This is an organizational and operational plan for the proposed system that includes forces, equipment, doctrine, and tactics. In other words, it describes the doctrine and/or tactics by which forces and equipment deployed in the battlefield.

No significant change in operational concepts, such as organization, doctrine, tactics, and so on will be considered in this thesis. The concept of the fire support remains same as described in Chapter II.

IV. ALTERNATIVES

A. PERFORMANCE OBJECTIVES

This part of the COEA specifies the minimum acceptable operational requirements for the performance of the proposed concept or system. Both current systems and improved versions should be considered along with systems in development by other services or allies and conceptual systems which are not yet on the drawing board.

There are many characteristics which affect the performance of the artillery systems. In this section, the key characteristics will be explained briefly and will be quantified.

1. Range

One important mission of the field artillery in the modern battlefield is deep battle. The North Korean artillery systems have maximum ranges, 15.4 km for the 122 mm Howitzer (H), 27.15 km for the 130 mm Gun (G), 12.4 km for the 152 mm H, 24 km for the 152 mm G, 29 km for the new 152 mm H (2A65). The new system should be able to provide fire support with a maximum range of 30 km to avoid the enemy's fire and to attack the deep targets.

2. Response Time

Current artillery systems have a response time around 10 minutes. Because the pace of battle is getting faster and faster, a new system should respond to a fire request within one minute while moving. When placed in firing position, the response time should be less than 30 seconds from the receipt of the fire mission request to the first round fired.

3. Rate of Fire

The new system shall be capable of delivering a maximum rate of fire of 10 rounds per minute for at least 3 minutes, followed by a sustained rate of fire four rounds per minute with on-board ammunitions.

4. System Quality Factors

The system reliability can be measured by Mean-Time-Between-Failures. The system MTBF should be greater than 72 hours in a combat situation. The system Mean-Time-to-Repair (MTTR) should be less than 5 hours at the user level. The tube life of the new system should be longer than 3000 Effective Full Charge (EFC) rounds.

5. Ammunition and Fuze

Because targets on the modern battlefield are diverse, the kinds of the ammunition and methods of attack are also varied. A direct support (DS) unit which supports closer maneuver units will be tasked with more varied kinds of fire missions. A new howitzer should be able to fire the kinds of ammunition as specified Chapter II.

6. Mobility and Armament

The system should be self-propelled, armored, tracked and capable of operating on the modern battlefield. The mobility should keep pace with supported maneuver forces (K-88 tank : 40 MPH on the road and 25 MPH cross-country) over both roads and cross-country.

In addition to the primary armament of the new system, the system should employ an M2 machine gun or equivalent system with equal or higher performance as a self defense system.

7. Others

For compatibility of existing ammunition, interoperability with the allied countries, and to reduce logistics problems, a 155 mm self-propelled howitzer is preferred as a future major artillery system for the Korean Army.

To shorten response time and to increase accuracy of fire, a computerized fire control and direction system should be added to the new system.

For the rapid connection and reliable communication, the new system should have a secured radio digital command, control, communication, and intelligence (C³ I) system.

B. DESCRIPTION OF ALTERNATIVES

This part of the COEA identifies the alternatives to be considered as the set of possible solutions. Each alternative is fully described by not only hardware specifications, but also doctrine and tactics that might be changed by new organizational and/or operational plans.

1. Home Development or Modification

a. Development of a New System

Developing a new system is one possible alternative. South Korea has some experience to co-produce M109 series howitzers and to develop the 130 mm Multiple Rocket Launcher. There is enough technical background, but the cost effectiveness of home development should be carefully analyzed. Research and Development (R&D) costs of several U.S. Army

artillery systems can be a good estimate for the new system. This estimate will be shown in Chapter V.

b. MRL

The Korean Army has the 130 mm 36-round Multiple Rocket Launcher (MRL), which has a maximum range of 36 km. Some of its specifications are shown in the Table 4-1.

Table 4-1. Specifications of the 130 mm MRL

Classification		Specification
Caliber		130 mm
Number of Tubes		36
Length	Tube	3.4 m
	Rocket	2.55 m
	Rocket Motor	1.79 m
Weight	Complete Rocket	64 kg
	Warhead	21 kg
	Rocket Motor	33 kg
Range		12~36 km
Rate of fire		2 rounds/sec
Reloading Time		10 minutes
Crew		3

(Source : Jane's Armor and Artillery 1994-1995, p.709)

This system has some limits compared to the performance objectives presented in the previous section. This system fires only the pre-fragmented HE round with a contact (quick) fuze which contains 16000 small steel balls embedded in its structure. This makes its lethal area approximately 3600 square meters of a soft area target. More diverse ammunitions, such as DPICM, are required to satisfy the requirements of the modern battlefield.

The other limits of the MRL system are the mobility and survivability. This system is mounted on the five ton truck which can not cross the natural or artificial obstacles such as

mountainous terrain, barbed wire, etc. Mounting the MRL on an armored and tracked vehicle can solve this mobility problem as well as improve its survivability for the crew.

Because of the characteristics described this system could be a possible alternatives with some investment to satisfy all the requirements presented in performance objectives.

c. 155 mm (SP and Towed)

The Korean Army has two major cannon artillery systems. K-55 is a co-production system with BMY and KH-179 is a conversion of the U.S. M114A1. Most specifications of the K-55 are the same as M109A2, but KH-179 has significantly improved performance compared to M114A1.

Table 4-2. Specifications of the Howitzers of the Korean Army

Characteristics \ System	K-55	KH-179
Max. Range (km)	18	22
Max. Range (Assisted)	23.5	30
Response Time	5 min	10 min
Max. Rate of Fire	4 r/min	4 r/min
Sustained Rate of Fire	1 r/min	2 r/min
Speed (MPH)	35	45
Communication	wire	wire
SP/Towed	SP	Towed (5t)
Caliber	39	39
Reload	manual	manual
Crew	6	10

(Source : Jane's Armor and Artillery 1994-1995, p.552 & p.625)

These systems have the capability of firing various kinds of ammunition. However, a better response time, higher rate of fire, and more reliable communication system are required for the requirements of the future battlefield.

2. Import from Other Countries

a. 155 mm Howitzers

As mentioned in section 5, Chapter II, there are many new artillery systems world-wide either in developing or deploying. With only a few exceptions, most systems are 155 mm, self-propelled howitzers with minor differences in performance.

The comparison of major characteristics of those systems compared to the current system, M109A2/A3, is shown on the Table 4-3.

Table 4-3. Comparison of Some Systems

System	M109 A2/A3	M109 A6 (Paladin)	CRUSADER*	PzH 2000	CAESAR**
Max. Range (km)	18	24	40	30	
Max. Range (Assisted***)	23.5	30	50	40	40
Response Time****	10 min	1 min	25 sec	1 min	1 min
Max. Rate of Fire	4 r/min	4 r/min	10-12 r/m	3 r/10 sec	3 r/15 sec
Sustained Rate of Fire	1 r/min	1 r/min	6 r/min	8 r/min	6 r/min
Speed (MPH)	35	40		40	
Communication	intercom	radio		radio	
Combat Weight (lb)	55,000	63,600		52,000	37,000
Caliber	39	39	52	52	52
Reload	manual	semi-auto	automatic	automatic	automatic

* CRUSADER System is expected to equip in 2004, some characteristics are not available yet.

** CAESAR is not yet in production or service.

*** Assisted usually means projectile assisted by either rocket (RAP : Rocket Assisted Projectile) or ERFB-BB (Extended Range Full Bore-Base Bleed)

**** Response Time in here means required time for the first round shot from the movement or not in emplacement.

(Source : 1. Proceedings, 4th International Cannon and Artillery Firepower Symposium and Exhibition in June 19-22, 1995 and 2. Jane's Armor and Artillery 1994-95)

Among the alternatives, CRUSADER (U.S.A) and CAESAR (France) systems are in the developing, so no further analysis will be done in this thesis. The PALADIN (U.S.A) and PZH 2000 (Germany) systems are selected here as the alternatives to be considered for further analysis.

b. MLRS and ATACMS

The Multiple Launch Rocket System (MLRS) is an artillery rocket system composed of a tracked and self-propelled launcher, disposable pods and a fire control system. It was an international project, started from the U.S. Army and later UK, Germany, Italy, and France participated, in response to a disparity of the artillery strength between NATO and the former Warsaw Pact. It was one the fearest weapon systems by the Iraq forces during the Gulf war. It is the best system for the massing fire support.

Some of its specifications are shown Table 4-4.

Table 4-4. Specifications of the MLRS

Classification		Data
Number of Rockets		12
Rocket	Length	3.937 m
	Weight	307 kg
	Diameter	227 mm
Warhead	Weight	156 kg
	Submunitions	644 DPICM*
	Damaging area	200 x 100
Range		32-45 km**
Reloading		Launcher
Crew		1-3

* This is an shaped charge which can penetrate 76-102 mm and newer version has six SADARM submunitions.

** 32 km for the phase I launcher and 45 km for Extended Rocket

(Source : Jane's Armor and Artillery 1994-95, pp. 693-696)

The U.S. Army has developed a new artillery rocket system called the Army Tactical Missile System (ATACMS). It is fired from the MLRS launcher using off-axis guidance techniques to prevent enemy radars from tracking the trajectory so that it can avoid an enemy's counter-battery fire. Each missile is 3.96 m long and 0.61 m in diameter and with a range over 100 km. The warhead weighs 591 kg and contains approximately 950 anti-personnel and anti-materiel bomblets which are dispersed over the target area to detonate upon impact.

Both systems have great capabilities for massing fire and deep attack. However, these rocket systems are not proper for supporting close combat. Thus these systems can be possible alternatives to make up for the inferiority of artillery as a GS or GSR mission. There for these systems are not considered to be a alternative any more.

V. ANALYSES OF ALTERNATIVES

A. ARTILLERY MODEL

DoD Instruction 5000.2-M defines models to be a representation of an actual or conceptual system that involves mathematics, logical expressions or computer simulations. Models can be used in the COEA to compare the effectiveness of the various alternatives.

In this thesis, a model of artillery gunfire is used to analyze the effectiveness of alternatives presented in the previous chapter. The Figure 5-1 shows a brief flow chart of the model.

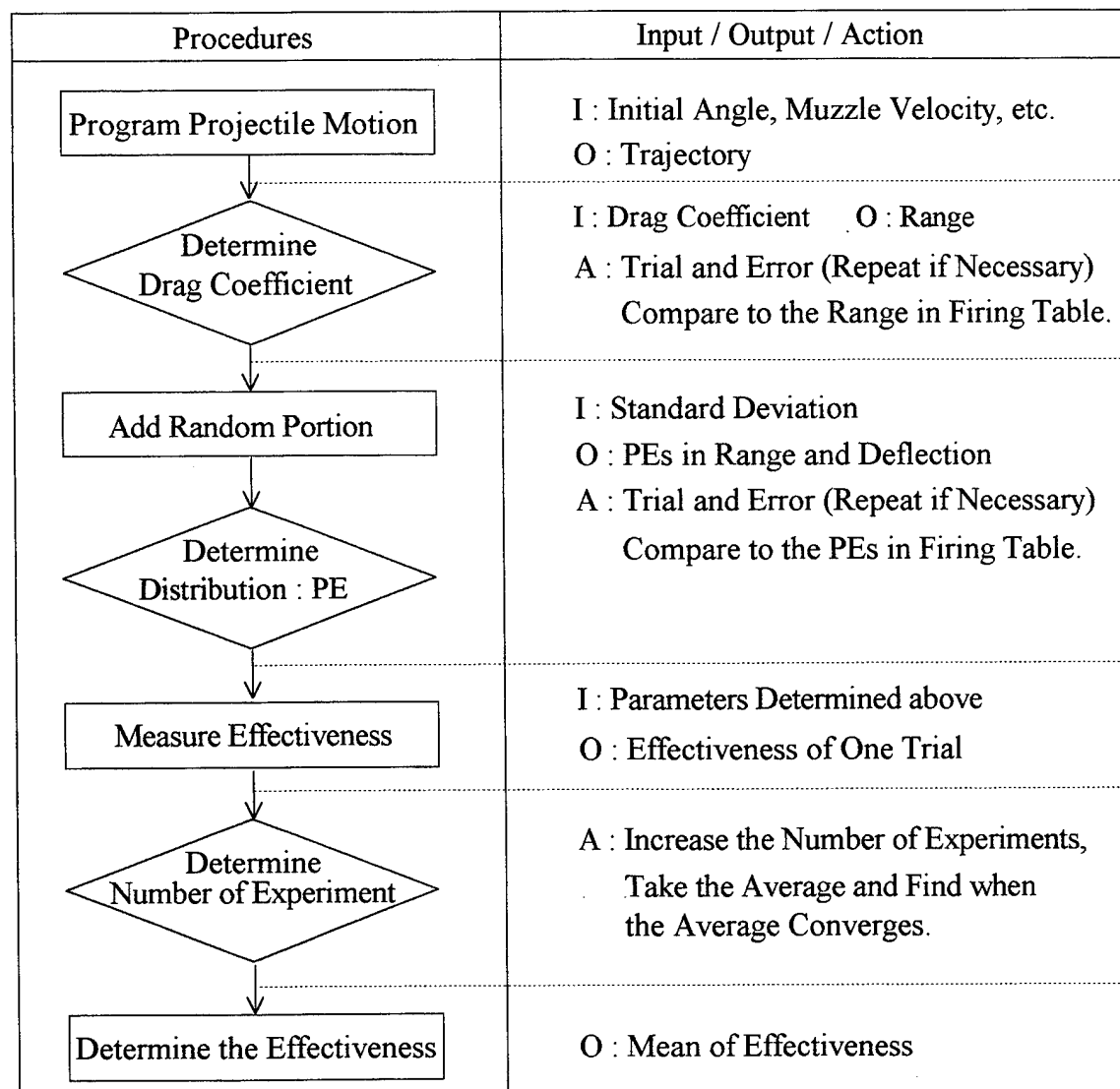

Figure 5-1. Flow of the Model

1. Projectile Motion with Gravity and Drag Force

The motion of an artillery round is three dimensional projectile motion with gravity and drag forces. In three dimension, all axis and angles are defined as follows and showed in the Figure 5-2. The axis are assigned as typical right hand coordinate system (x , y , and z axis represent deflection, range, and altitude, respectively). The initial velocity is V_0 , the elevation (the vertical angle between muzzle and ground) is θ_0 , and the horizontal angle from the yz plane to gun is ϕ_0 .

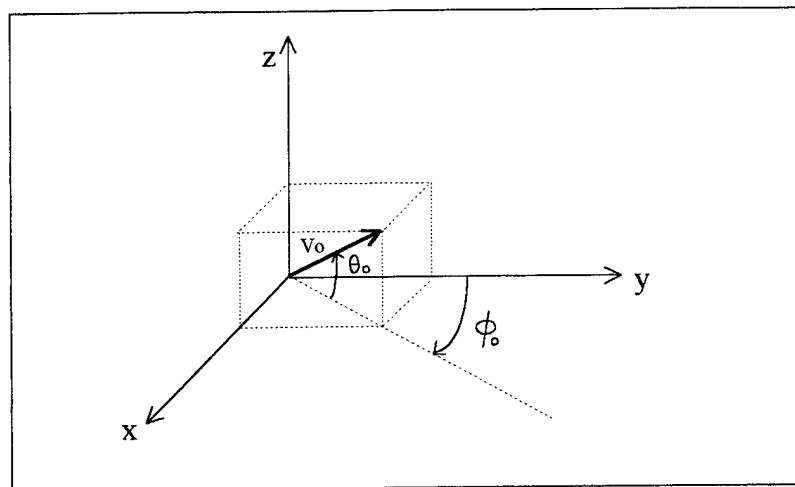

Figure 5-2. Coordinate System for the Model

Let projectile velocity vector

$$\vec{V} = V_x \hat{x} + V_y \hat{y} + V_z \hat{z}$$

where \hat{x} , \hat{y} , and \hat{z} represent unit vector of each direction.

The given initial velocity of projectile is can be divided into the form,

$$V_{x0} = V_0 \cos \theta_0 \sin \phi_0, V_{y0} = V_0 \cos \theta_0 \cos \phi_0, \text{ and } V_{z0} = V_0 \sin \theta_0 \cos \phi_0.$$

The equation of the motion will be

$$\vec{F} = -m \vec{g} - \frac{1}{2} C \rho A \left| \vec{V} \right|^2,$$

where ρ is air density, g is the acceleration of gravity, m is projectile mass, V is velocity, C is drag coefficient, and A is cross-sectional area of projectile.

$$\text{or } m \dot{\vec{V}} = -mg \hat{z} - \frac{1}{2} C_D \rho A V \vec{V}$$

Divide the above equation by m and separate it into 3 dimensions,

$$\dot{V}_x = -kVV_x, \dot{V}_y = -kVV_y, \text{ and } \dot{V}_z = -g - kVV_z, \text{ where } k = (C_D A)/2m.$$

Among the variables used in above equations A , g , and m are fixed parameters, but ρ depends on the height (z) of the projectile. The Firing Table shows 155 mm howitzer trajectory passes maximum height 10,000 to 11,000 meters. (Reference : Appendices A through K, Firing Table FT 155-AM-2). The variation of the air density for the standard atmosphere is given by the Table 5-1.

Table 5-1. Air density at the different altitude

Height (m)	Air density (kg/m ³)	Height (m)	Air density (kg/m ³)
0	1.2255	6,000	0.6596
500	1.1677	6,500	0.6237
1,000	1.1120	7,000	0.5893
1,500	1.0583	7,500	0.5564
2,000	1.0067	8,000	0.5250
2,500	0.9570	8,500	0.4949
3,000	0.9092	9,000	0.4661
3,500	0.8633	9,500	0.4387
4,000	0.8191	10,000	0.4125
4,500	0.7768	10,500	0.3875
5,000	0.7361	11,000	0.3637
5,500	0.6970	11,500	0.3361

(Source : The U.S. Standard Atmosphere, pp. 39-53)

A plot of the air density against height with fitted lines is shown on the Figure 5-3. As shown on the figure, the second and third-order fitted points are almost the same and very close

to the actual data points. The coefficient for fourth-order is nearly zero, less than 10^{-5} . The third-order equation for the air density is,

$$\rho = 1.2263 - 0.1189 z + 0.0046 z^2 - 0.0001 z^3$$

where z is the altitude of the projectile in km.

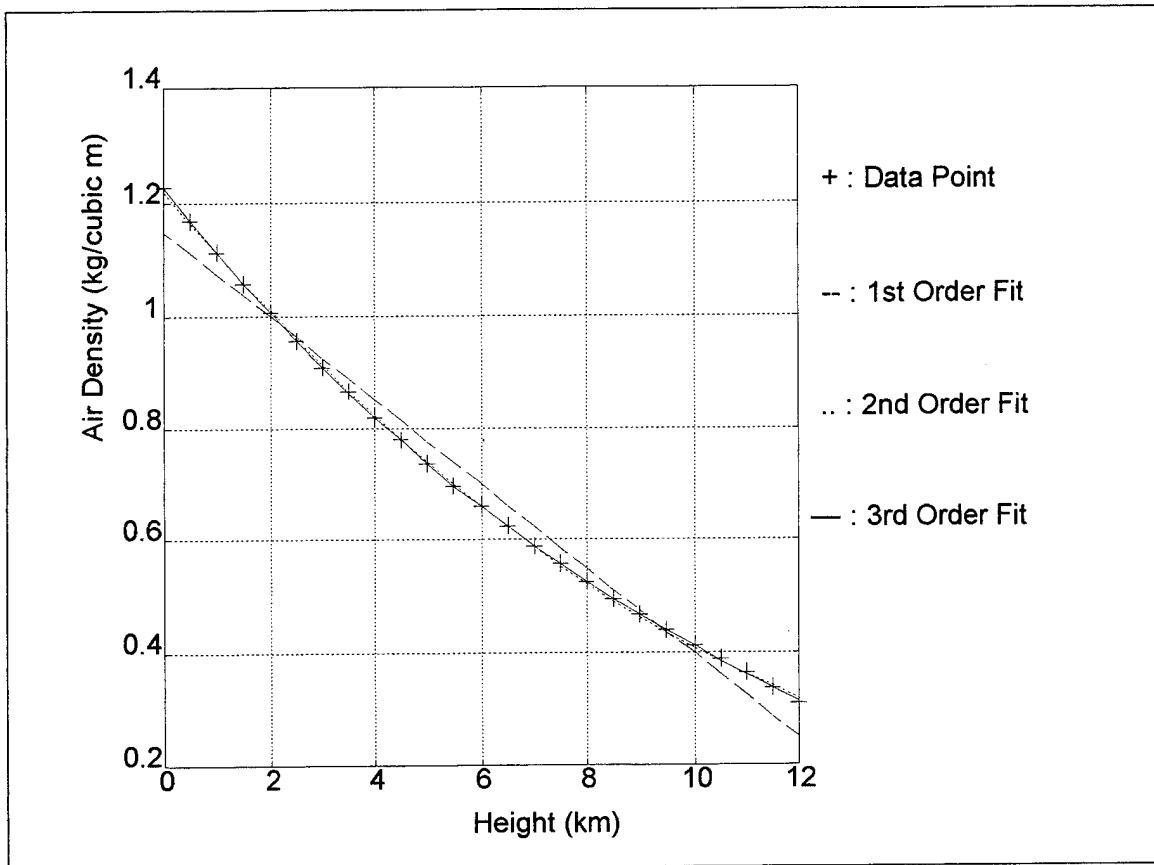

Figure 5-3. Plot Air Density against Height

The drag coefficient, C , varies as the speed, air temperature, and air density changes. For the simulation, it can be assumed to be a fixed variable and is determined by trial and error for given initial conditions.

Let the initial condition of projectile be the location of gun, that is $x_0=0$, $y_0=0$, $z_0=0$, and the vertical angle from the ground to the gun is θ_0 . Assume the projectile starts along the path only on yz plane, then $\phi_0 = 0$.

With all of above variables and initial conditions and equations of motion, the trajectory data can be computed using the Euler-Cromer method. This method was programmed using the

'C' language, and the listing is given in Appendix B. Appendix C shows the projectile trajectories for several different charges. Note that the charge is combined with an elevation angle such that a specific range is achieved.

2. Hit Distribution and Random Numbers

In reality, the artillery rounds follow this model with some stochastic distribution. The Firing Table states that artillery rounds have a normal distribution in range and in deflection with a certain probable error in meter at any specific range and charge.

Random numbers generated by the computer's random number generator can be used to simulate this distribution. It generates integers randomly between zero and $2^{31}-1$ with a uniform distribution. The random number can be normalized by dividing generated numbers by $2^{31}-1$. Then r , the set of the random numbers between zero and one, is a uniform distribution as shown in the Figure 5-4.

The probability function will be,

$$p_r(r) = 1 \quad 0 \leq r \leq 1$$

$$p_r(r) = 0 \quad \text{otherwise.}$$

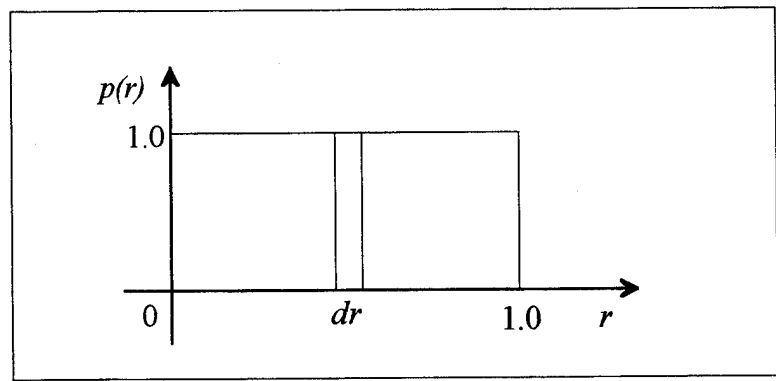

Figure 5-4. Uniform Distribution

The relationship between the uniform distribution and any kind of probability density function, $p(x)$, for example Figure 5-5, is,

$$p(x) dx = p(r) dr$$

$$\text{so } r = \int p(x) dx \dots \dots \dots (1)$$

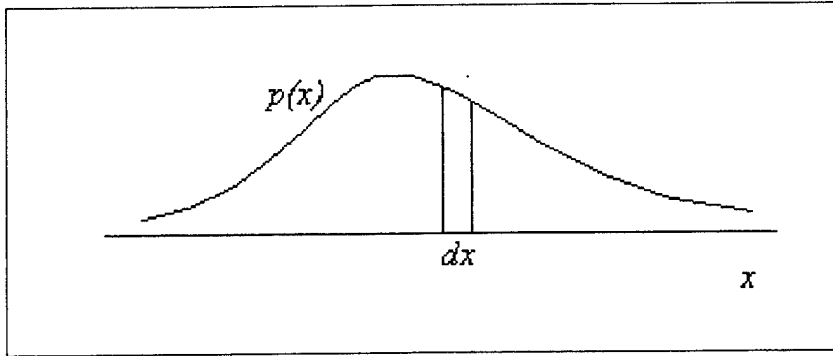

Figure 5-5. Continuous Probability Distribution Function

Assume that the distribution of an artillery projectile is caused by distributions of initial gun elevation, θ , deflection angle, ϕ , and muzzle velocity, V_m . For the simulation, let the angular fluctuation around the gun barrel, $d\theta$, create a velocity error, dV . Then the velocity error can be given in the form of $dV = V d\theta$, where $d\theta$ is the angular error between aiming point and actual gun barrel. Note that $d\theta$ is caused not only by the error of the initial elevation but also by the error of the initial deflection.

At the muzzle, dV has a certain distribution on the xz plane, so the bivariate normal distribution is a good assumption to model this distribution. From the standard bivariate normal distribution function with zero correlation coefficient (i.e. the errors in elevation and that in deflection are independent),

$$p(x, z) = \frac{1}{2\pi\sigma_x\sigma_z} \exp\left(-\frac{1}{2}\left[\frac{(x - \mu_x)^2}{\sigma_x^2} + \frac{(z - \mu_z)^2}{\sigma_z^2}\right]\right),$$

where x and z are the independent variables, μ_x and μ_z represents mean values, and σ_x and σ_z are the standard deviations of the random variables, x and z .

Assume $\mu_x = 0$, $\mu_z = 0$, and $\sigma_x = \sigma_z = \sigma$,

$$\text{then } p(x, z) dx dz = \frac{1}{2\pi\sigma^2} \exp\left(-\frac{1}{2\sigma^2}[x^2 + z^2]\right) dx dz \dots\dots\dots (2)$$

$$\text{Let } \lambda = \frac{(x^2 + z^2)}{2\sigma^2}, s^2 = x^2 + z^2, x = s \cos\omega, z = s \sin\omega, \text{ and } \omega = \tan^{-1}\left(\frac{z}{x}\right)$$

$$\text{then } p(x, z) dx dz = \frac{e^{-\lambda}}{2\pi\sigma^2} dx dz \dots\dots\dots(3)$$

$$\text{but } dx dz = s ds d\omega = \sigma^2 d\lambda d\omega, \text{ from } \lambda = \frac{s^2}{2\sigma^2}$$

$$\text{so } p(x, z) dx dz = p(s, \omega) d\lambda d\omega = (e^{-\lambda} d\lambda) \left(\frac{d\omega}{2\pi}\right) \dots\dots\dots(4)$$

Which is a product of the exponential distribution and the uniform distribution. From equation (1) for the exponential distribution, $p(\lambda)$, and uniform distribution, r , we have

$$\lambda = -\ln(r_i) \dots\dots\dots(5)$$

$$\text{and } \omega = 2\pi r_j \dots\dots\dots(6),$$

where $r_i \neq r_j$. (i.e. different random numbers)

Put equation (5), (6) and $s = \sigma\sqrt{2\lambda}$ into $x = s \cos\omega$ and $z = s \sin\omega$,

$$\text{then } x = \sigma\sqrt{-2\ln(r_i)} \cos(2\pi r_j) \dots\dots\dots(7)$$

$$\text{and } z = \sigma\sqrt{-2\ln(r_i)} \sin(2\pi r_j) \dots\dots\dots(8).$$

The initial muzzle velocity, V_m , also has a distribution. Assume that it follows the Gaussian distribution with mean value V_0 and standard deviation dV_0 . Following the same procedures mentioned above yields,

$$V_m = V_0 + dV_0 \sqrt{-2\ln(r_k)} \cos(2\pi r_l) \dots\dots\dots(9),$$

where $r_k \neq r_l$.

The x and z components of velocity have random distribution associated with equations (7) and (8), respectively. Put $\sigma = Vd\theta / \sqrt{2}$ into equations (7) and (8), and rewrite dV_x and dV_z by using equations (7) and (8),

$$\text{then } dV_x = \frac{Vd\theta}{\sqrt{2}} \sqrt{-2\ln(r_i)} \cos(2\pi r_j) \dots\dots\dots(10)$$

$$\text{and } dV_z = \frac{Vd\theta}{\sqrt{2}} \sqrt{-2 \ln(r_i)} \sin(2\pi r_j) \dots \dots \dots (11).$$

Note that dV_y (y component of the velocity error caused by the angular error) is neglected because the magnitude of it is much smaller than the dV_o which is the error of initial velocity.

Put V , given by equation (9), into equations (10) and (11), and add the revised equations to the program as the random portion of the projectile motion. Appendix D is the 'C' program to determine the standard deviations of angle and velocity. This program contains sorting function which orders errors and calculate the probable errors (PEs).

Run this program with random firing data and check the PEs as the number of fires increases. Appendix E is a plot which shows how many rounds are required to get a converged PEs. The solid lines represent the PEs in deflection and the dotted lines show the PEs with several different firing data and arbitrary standard deviations. It shows 5000 rounds yielding the PEs within one meter and the PEs from 10,000 rounds converging to 0.2 m.

Now change the standard deviations of the angle and muzzle velocity, $d\theta$ (radian) and dv_0 (m/sec) in program, $d\theta$ from 0 to 0.005 with stepsize of 0.0001 and dv_0 from 0 to 2.5 with stepsize of 0.1, and check the PEs from 10,000 rounds. Appendix F shows the results from several different sets firing data. Determine the $d\theta$ and dv_0 by finding or interpolating with the nearest values for the given PEs at the specific range in the Firing Table.

Determining the standard deviation is the most critical part of the simulation because it directly relates the distribution of impact points that affect the effectiveness of each system. To confirm $d\theta$ and dv_0 , put the determined values into the program again, and run it one more time to check the PEs. The PEs in the Firing Table are stated by an integer number in every 1000 km. If the result shows the different PEs compared to the given PEs in the firing data, then repeat all of the above procedures with more round or smaller stepsize.

3. Target Descriptions and Assumptions

There are various kinds of targets in the battlefield. In this thesis, a 300 m x 50 m rectangular target is used as a standard for a six howitzer battery to compare the effectiveness of each alternatives. Assume each howitzer aims at one of the six equally spaced aiming points on the 300 m x 50 m target as shown in the Figure 5-6.

The damage to the target due to each round impact is determined as follows. Divide the target into one square meter (1 m x 1 m) cells (15000 cells for the 300 m x 50 m target). Once each round fires, examine the trajectory and find the impact point. The round is assumed to cause damage within the circle with a radius of 25 m. The number of damaged cells is determined by drawing a circle around the impact point with a radius of 25 m. Each cell will be examined as to whether it is damaged or not. After firing a volley, the ratio of damaged cells/area of the target is determined.

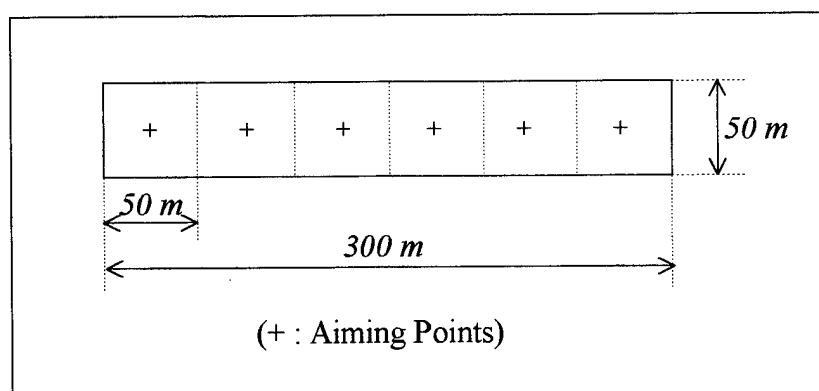

Figure 5-6. Target Size and Aiming Points

To measure and compare effectiveness, some more assumptions are required. First, there is no consideration for error in the gun position and target location. Second, the conditions of the atmosphere, howitzer, and projectile are considered to be standard. In other words, neglect, or assumed to be corrected, the differences of each howitzer, projectile, and weather condition. Third, subsequent hits on each cell does not contribute the damage. (i.e. only the first hit on the each cell damages to target).

Appendix H is the 'C' program that computes the cumulative damage on the area target by multiple firing. The result varies very much with a small number of trials because of the random distribution. However, as the number of the trials increases, the average converges to certain number. Appendix I shows the change of the average cumulative damage compared to the number of trials. It shows about 500 trials are required to get a converged average. Table 5-2 shows cumulative damage (averaged over 500 trials) to the stationary 300 m x 50 m target at the different ranges with different charges as the number of rounds increases.

The numbers in the table are the only relative measurement for comparing the performance and do not represent the ratio of actual damage. The number of rounds fired on a target in the combat situation is decided by the Fire Direction Officer (FDO) in accordance with the Joint Munitions Effectiveness Manual (JMEM). According to the JMEM, most cases of a fire mission require from three to five rounds to attack the targets, which are highlighted with a doubled line in the table. It will serve as criteria of the measures of effectiveness for each alternatives.

Table 5-2. Cumulative Damage to a Stationary Target

Range (km)	5	10			15
Round \ Charge	4	6	7	8	8
1	0.56	0.42	0.46	0.39	0.27
2	0.81	0.66	0.70	0.62	0.47
3	0.91	0.80	0.84	0.77	0.62
4	0.96	0.88	0.91	0.86	0.72
5	0.98	0.93	0.95	0.91	0.80
6	0.99	0.96	0.97	0.95	0.85
7	0.99	0.98	0.99	0.97	0.89
8	1.00	0.99	0.99	0.98	0.92
9	1.00	0.99	0.99	0.99	0.94
10	1.00	1.00	1.00	0.99	0.96

B. MEASURES AND ANALYSES OF EFFECTIVENESS

The analyses of effectiveness provide measures that assist in distinguishing the differences between alternatives. They show how the alternatives compare in meeting functional objectives. The measures should be related directly to the system's performance characteristics to satisfy the missions identified at the beginning of the acquisition program. Quantitative and objective measures of the effectiveness are recommended to minimize personal bias.

To measure the relative effectiveness of the alternatives, every possible engagement cases should be modeled and measured. There are many kinds of targets and engagement methods.

However, targets can be classified into two categories: stationary and moving. The effectiveness of attacking a stationary target, such as a command post, supply depot, and so on, is not dependent upon the rate of fire or response time as is a moving target. Consequently measure the effectiveness of the alternatives will be determined by running the simulation program with each system's rate of fire for different target mobile characteristics.

In this thesis, a moving target means that all, or any portion of the target, can change its position during the attack so that the damage would be reduced. This movement can be categorized into two way: dispersion and linear in any direction.

1. Rate of Fire

The rate of fire is one of the important characteristics related directly to the fire support capability of the artillery system. The current systems, such as the M109 series, have a maximum rate of fire four rounds per minute in three minutes and a sustained rate of fire one round per minute. As shown on the Table 4-3, the alternatives have a much faster rate of fire than current systems.

a. Dispersing Target

A good example of this target is an assembly area. Assumptions for this engagement are as follows. The first round hits the same condition as a stationary target. The non-damaged portion of the target disperses in all directions with a certain speed within a boundary. Assume that the speed varies from 2.5 m/min to 100 m/min with, a maximum movement of 100 m in each direction. As an example, Figure 5-7 shows the target size every minute if the dispersion speed is 50 m/min.

As shown in the figure second volley impacts on the target size 400 m x 150 m. In other words number of target cells is increased from 15,000 to 60,000. The number of cells when the third volley impacts is 125,000.

Let the initial condition of the target be unity, and d_i represents the damage caused by the i th volley. The first volley will damage the target by d_1 . The second volley impacts the target which will be $1-d_1$ in the size 350 m x 100 m if the target disperses with the speed of 50m/min and the rate of fire is one round per minute. After the completion of the second volley, the program will measure the damage on the target with expanded size. Let the damage be d_2 . The cumulative damage, caused by the first and second volleys will be $d_1 + d_2(1-d_1)$. This procedure of

measuring the damage will be continued for subsequent volleys. Appendix H is the program that contains this procedure to measure the effectiveness of artillery attacking a dispersing target by using proper variables.

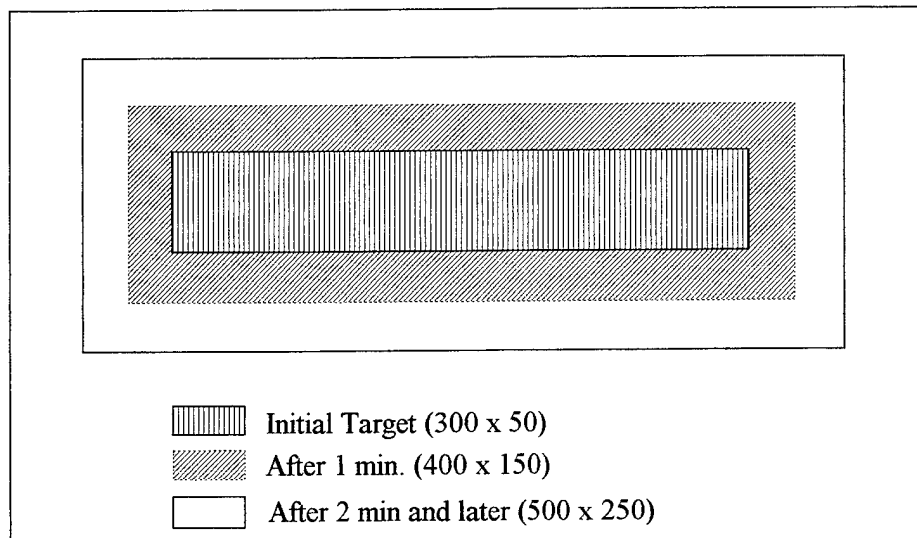

Figure 5-7. Dispersing Target with Speed 50 m/min.

Table 5-3 shows the cumulative damage by the one-round-per-minute cannon battery against the target with the speed 50 m/min. As shown in the Table 5-3, five rounds are not enough to satisfy the fire mission for the dispersing target. Even after ten rounds of fire, the cumulative damage is less than 80 percent for most of the experiment.

If the rate of fire is increased, it is clear that subsequent volleys can impact on a smaller target so that the target will be damaged more. Table 5-4 shows the cumulative damage against the same target described earlier with an increased rate of fire of four rounds per minute, and Table 5-5 shows the results with ten rounds per minute. Numbers in the parentheses in the Tables 5-3 through 5-8 represent the number of charges. Assume that each target is attacked by six volleys, and the results of sixth rounds are highlighted with doubled line in the tables. More measures of effectiveness with various conditions are attached in Appendix I.

The reason of choosing six volleys is for convenience to compare the performance, even though JMEM recommends between three to five rounds. In other words, the six volleys can be fired either six volleys by one battery, three volleys by two batteries, or two volleys by three batteries.

Table 5-3. Target Size and Cumulative Damage for 1 round/min

Round	Target Size (m x m)	Damage				
		5 km (4)	10 km (6)	10 km (7)	10 km (8)	15 km (8)
1	300 x 50	0.55	0.41	0.45	0.38	0.27
2	400 x 150	0.64	0.53	0.56	0.50	0.39
3	500 x 250	0.68	0.57	0.60	0.54	0.45
4	500 x 250	0.71	0.61	0.64	0.59	0.50
5	500 x 250	0.74	0.65	0.67	0.63	0.55
6	500 x 250	0.76	0.68	0.70	0.66	0.59

Table 5-4. Target Size and Cumulative Damage for 4 rounds/min

Round	Target Size (m x m)	Damage				
		5 km (4)	10 km (6)	10 km (7)	10 km (8)	15 km (8)
1	300 x 50	0.56	0.42	0.46	0.39	0.27
2	325 x 75	0.75	0.62	0.66	0.59	0.46
3	350 x 100	0.83	0.73	0.76	0.70	0.58
4	375 x 125	0.87	0.79	0.82	0.77	0.66
5	400 x 150	0.90	0.83	0.86	0.81	0.71
6	425 x 175	0.92	0.86	0.88	0.84	0.75

Table 5-5. Target Size and Cumulative Damage for 10 rounds/min

Round	Target Size (m x m)	Damage				
		5 km (4)	10 km (6)	10 km (7)	10 km (8)	15 km (8)
1	300 x 50	0.56	0.42	0.46	0.39	0.27
2	310 x 60	0.78	0.65	0.69	0.61	0.47
3	320 x 70	0.88	0.78	0.81	0.74	0.60
4	330 x 80	0.93	0.85	0.88	0.83	0.70
5	340 x 90	0.96	0.90	0.92	0.88	0.77
6	350 x 100	0.97	0.93	0.94	0.91	0.82

Figure 5-8 shows how the cumulative damage after six rounds varies as the rate of fire changes with different target speed. Each range and charge combination has one set of three different type lines. As shown in the figure, the effectiveness to the stationary target (speed = 0) have the same value (three lines start from one point), and those of the ten-rounds-per-minute howitzer dropped less than 10 percents compared to a stationary target while those of the one-round-per-minute and four-rounds-per-minute lowered significantly.

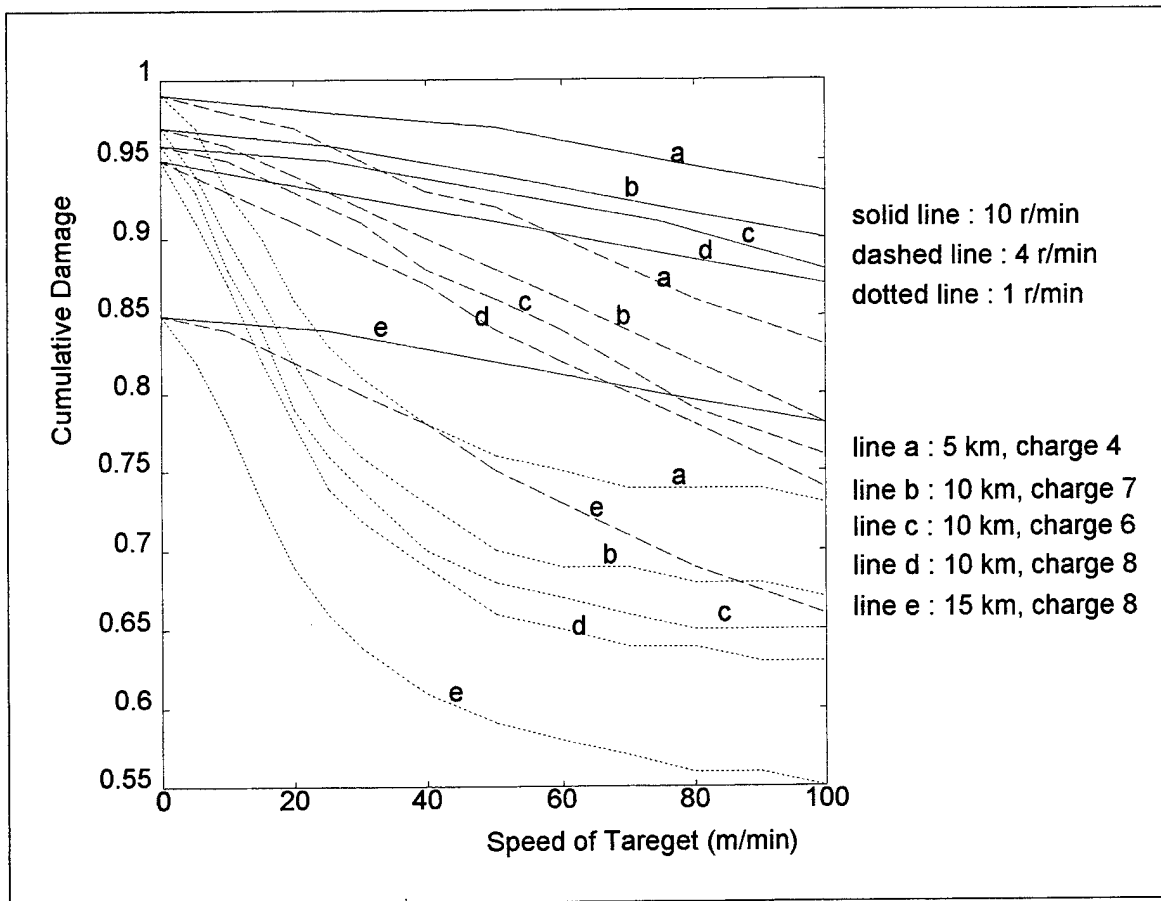

Figure 5-8. Cumulative Damage after Six Rounds with Different Rate of Fire

To achieve the same damage with the four-rounds-per-minute howitzers as the ten-rounds-per-minute battery achieved, the number of firing unit should be increased. Figure 5-9 shows the effectiveness of six volleys by one ten-rounds-per-minute howitzer battery, three volleys by two four-rounds-per-minute howitzer batteries, and two volleys by three four-rounds-per-minute howitzer batteries. As shown on the Figure 5-9 the effectiveness of a ten-rounds-

per-minute howitzer battery is approximately the same as that of the two four-rounds-per-minute howitzer batteries.

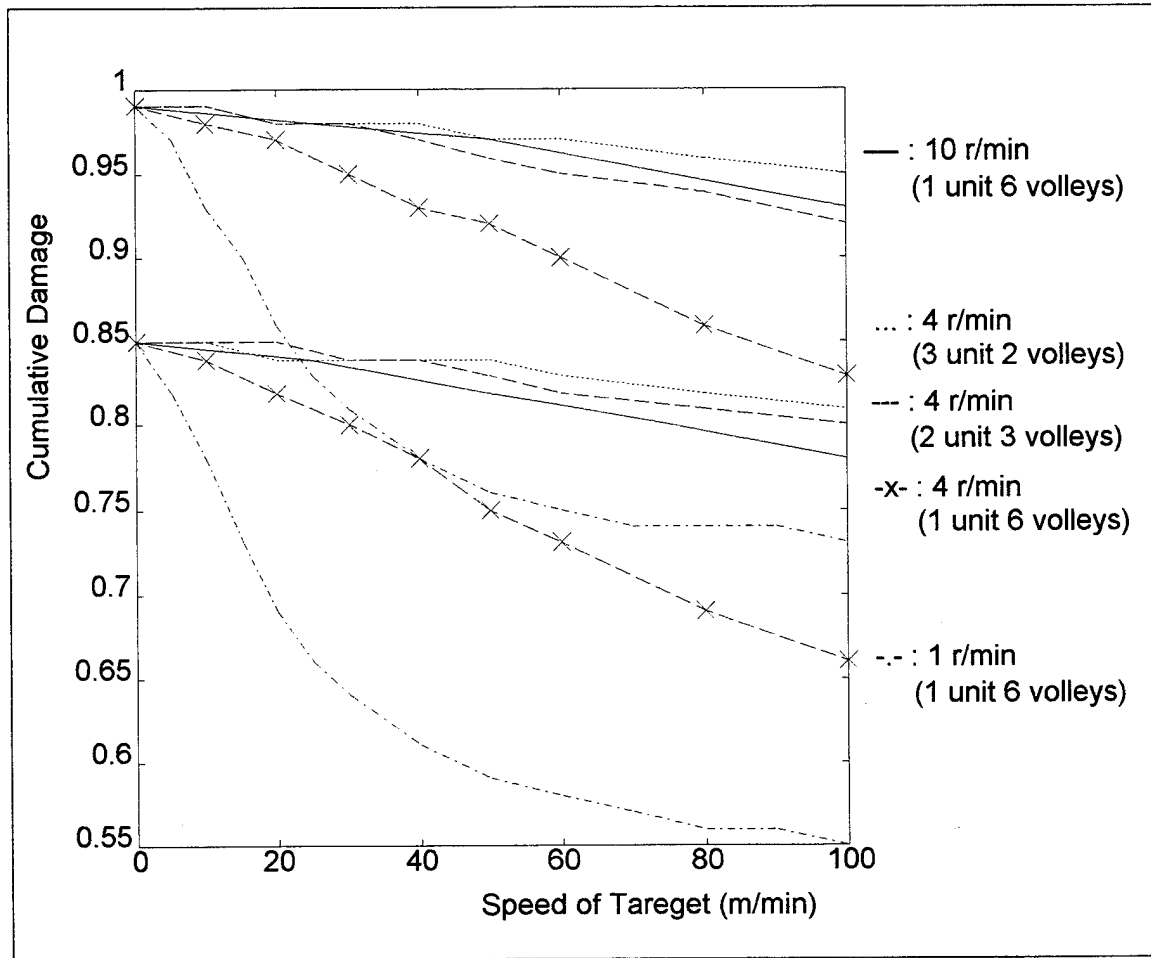

Figure 5-9. Relative Effectiveness of the Different Systems to Dispersing Target

b. Target Moving Linearly

Actual movement of the forces in the battlefield is usually not a linear maneuver. However, some maneuvers, for example a road marching unit, in a short moment can be modeled as a linear movement. If the speed of target at the moment is v (m/min), then the new location of the target at a later time will be vt , where t is the time between the volleys.

Figure 5-10 shows how the speed of a target and the rate of fire are related to damage. This relationship is shown in the plot of cumulative damage to the target caused by two different kinds of howitzer batteries (a four-rounds-per-minute and a ten-rounds-per-minute) with

different target speeds at the range of 15 km. As shown in the Figure 5-10, with a four-rounds-per-minute howitzer the first round is the only cause of damage when the target moves faster than 600 m/min. However, the second and third volleys of a ten-rounds-per-minute howitzer can damage the target when it moves with a speed of 1000 m/min, even though the additional damage is very small. The other results at the other ranges with different charges are similar.

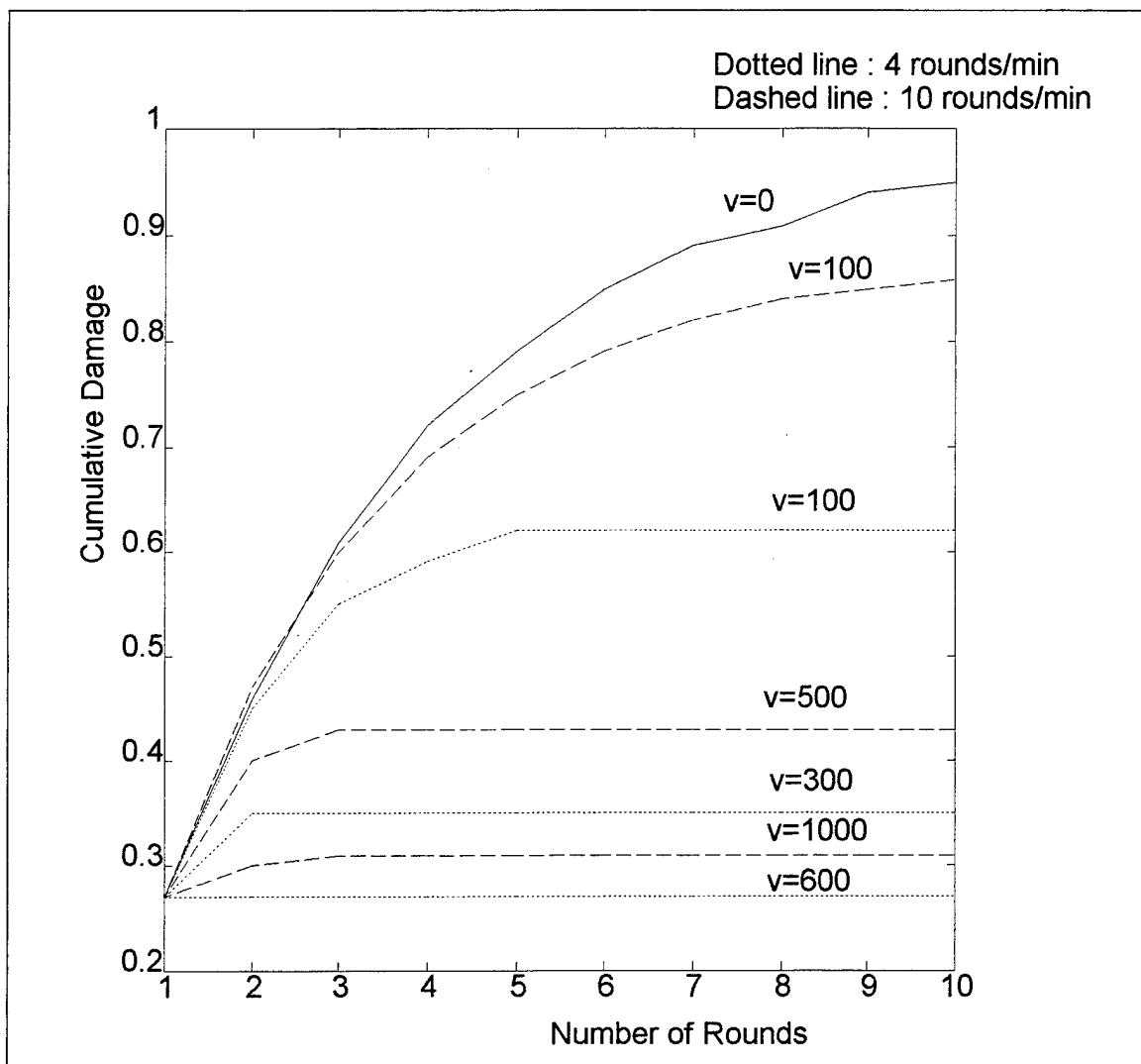

Figure 5-10. Cumulative Damage with Different Target Speed

As an example, assume that the target approaches along the firing direction with the speed of $v = 200$ m/min (7.5 miles/hour). Tables 5-6 through 5-8 show the cumulative damage at different ranges and charges by each weapon system with different rate of fire.

Table 5-6. Cumulative Damage by 1 round/min

Round	Target	Damage				
	Location (m)	5 km (4)	10 km (6)	10 km (7)	10 km (8)	15 km (8)
1	Range	0.55	0.41	0.45	0.38	0.27
2	-200	0.55	0.41	0.45	0.38	0.27
3	-400	0.55	0.41	0.45	0.38	0.27
4	-600	0.55	0.41	0.45	0.38	0.27
5	-800	0.55	0.41	0.45	0.38	0.27
6	-1000	0.55	0.41	0.45	0.38	0.27

Table 5-7. Cumulative Damage by 4 rounds/min

Round	Target	Damage				
	Location (m)	5 km (4)	10 km (6)	10 km (7)	10 km (8)	15 km (8)
1	Range	0.55	0.41	0.45	0.38	0.27
2	-50	0.59	0.50	0.52	0.48	0.40
3	-100	0.59	0.51	0.53	0.49	0.43
4	-150	0.59	0.51	0.53	0.49	0.43
5	-200	0.59	0.51	0.53	0.49	0.43
6	-250	0.59	0.51	0.53	0.49	0.43

Table 5-8. Cumulative Damage for 10 rounds/min

Round	Target	Damage				
	Location (m)	5 km (4)	10 km (6)	10 km (7)	10 km (8)	15 km (8)
1	Range	0.55	0.41	0.45	0.38	0.27
2	-20	0.73	0.61	0.65	0.58	0.46
3	-40	0.75	0.69	0.71	0.67	0.57
4	-60	0.76	0.72	0.73	0.7	0.63
5	-80	0.76	0.73	0.73	0.72	0.66
6	-100	0.76	0.73	0.73	0.72	0.67

Figure 5-11 is a plot of the results of the same analysis as done with a dispersing target with the different systems and different number of firing units at the range of 15 km.

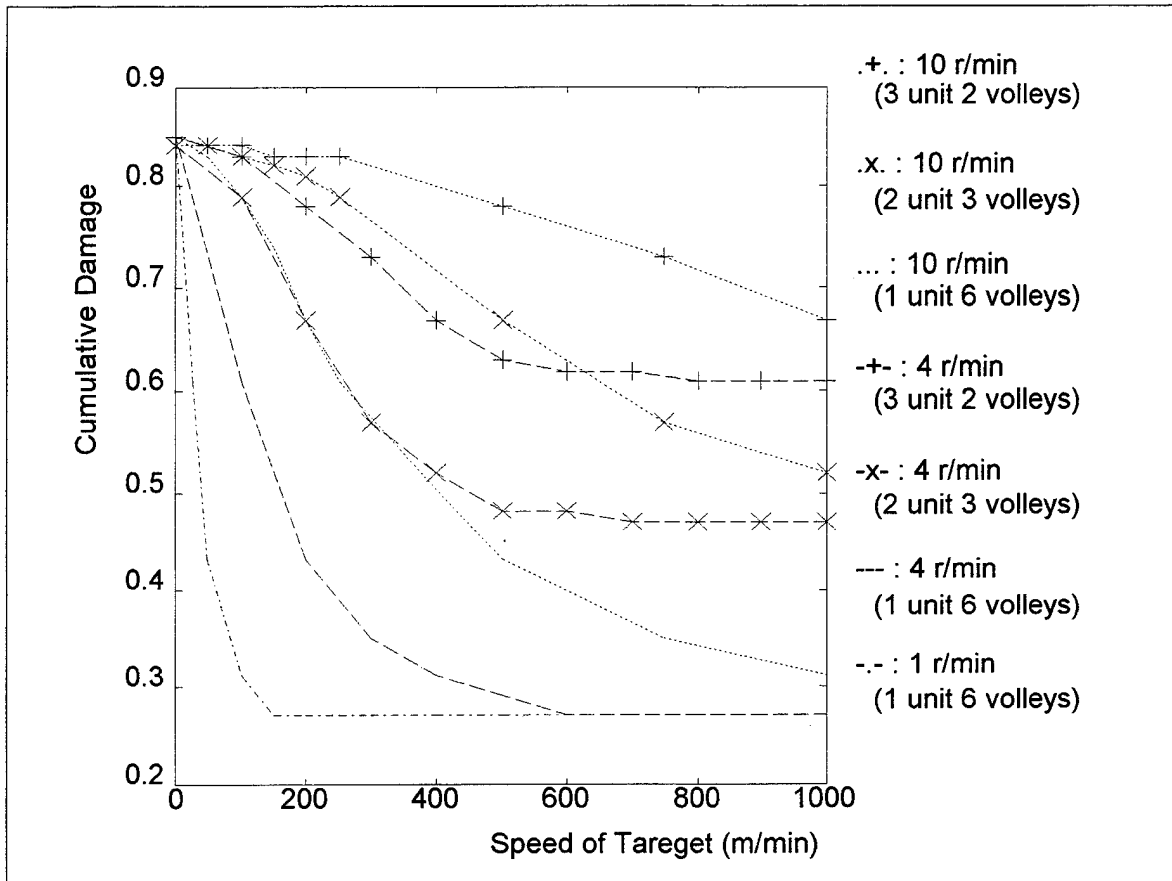

Figure 5-11. Relative Effectiveness of the Different Systems to Linearly Moving Target

This plot shows the damage caused in each case decreases as the speed of the target increases. The damage caused by the higher rate of fire decreases less than by the lower rate of fire in the case of increasing target speed. According to the Figure 5-11, the relative effectiveness of the different systems varies as target speed changes. Most vehicles in the modern battlefield can maneuver with a speed of between 15 miles per hour (400 m/min) and 30 miles per hour (800 m/min). In this speed range, three four-rounds-per-minute howitzer batteries can cause roughly the same damage as that caused by two batteries of ten-rounds-per-minute howitzer.

2. Response Time

Response time is another important characteristic of artillery performance. As shown in the Table 4-3, current systems have a response time around ten minutes. In other words, a moving firing unit requires ten minutes for the first round of fire. That means the target can move, attack, fire, or take any other action for ten minutes without any interference. Even if the unit fires after ten minutes, the enemy may move far away from the position fired at.

If the target is an enemy's artillery, their firing at the friendly position for ten minutes of firing without any restriction is enough for them to accomplish their mission, or to move to another position, because their artillery system has a similar rate of fire capability.

C. COSTS

A cost estimate is another important issue of the acquisition program. Decision makers must combine cost estimates with measures of operational effectiveness. This should be a life cycle cost (LCC) estimate for each alternative. However, LCC is usually a rough estimate, particularly those costs associated with system operation and support. A careless analysis of the LCC wastes budget and sometimes causes political and/or diplomatic problems, especially if the program requires importing weapons.

As mentioned in introduction, there are only limited data available and the focus of this thesis is on the analysis of the effectiveness. So the remainder of this thesis will briefly explain the contents of the rest parts of a COEA and short analysis with the data available.

1. Life Cycle Cost

There are several standard weapon system costs and components of the costs. Figure 5-12 shows the concept and composition of each standard cost.

The contractors asking price is usually the program acquisition cost plus their profit. However, from the DOD or program manager's view point, the LCC is more important because LCC contains operation and support costs, which can be much larger than the program acquisition cost and is very sensitive to the system's performance.

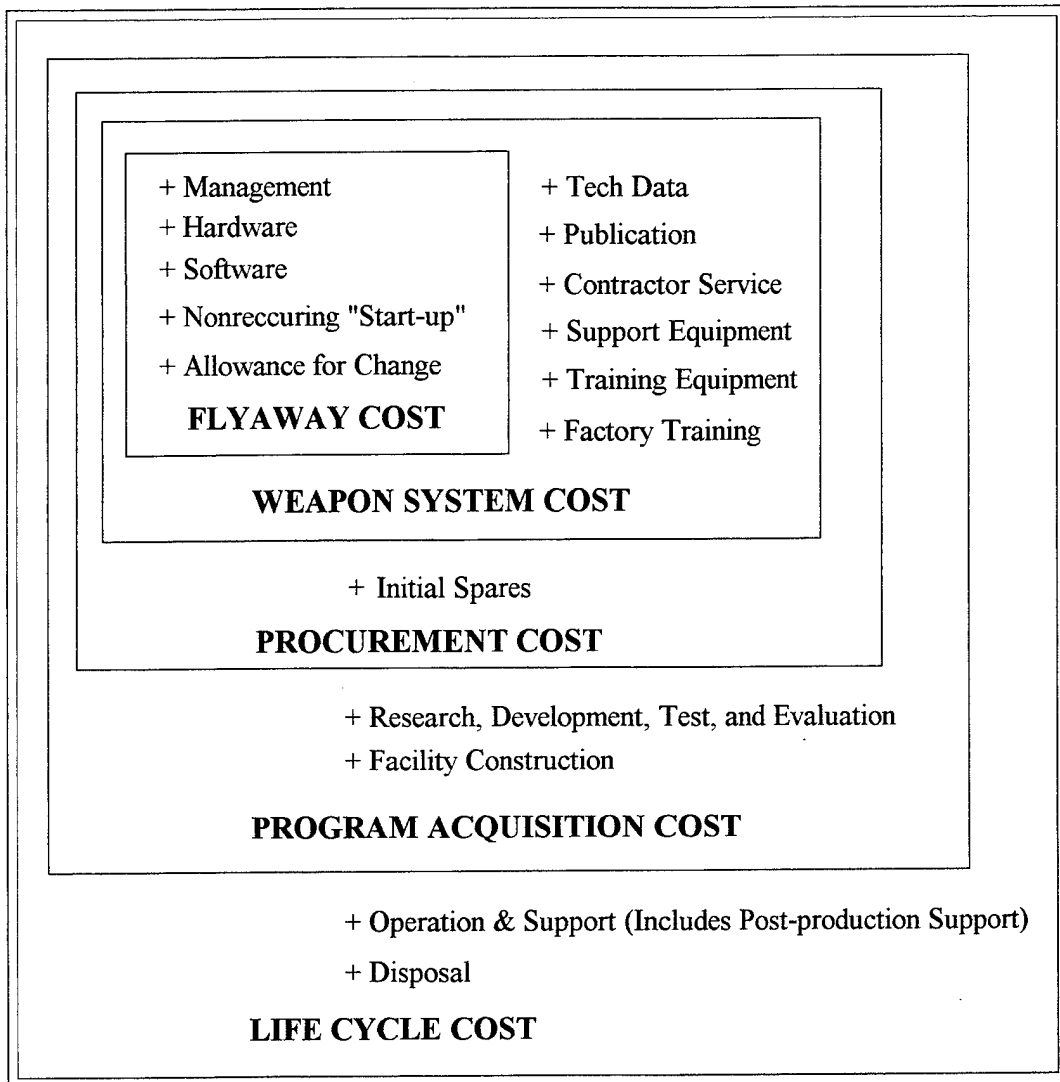

Figure 5-12. Relationship and Composition of the Standard Costs
 (Source : System Engineering Management Guide p.17-3)

2. Estimating Techniques

There are several cost estimating techniques. Sometimes, two or more methods can be used together to estimate a given program LCC. The most appropriate method, or methods, should be selected by a case-by-case basis.

a. Parametric Estimates

This method estimates the cost with particular element(s) that is a function of one or more technical, physical, or other parameter(s) considered to be most closely related to the cost, such as the rate of fire and response time in the artillery system. This analysis requires a

statistical data base, and the accuracy of the estimate is highly dependent upon the quantity and quality of the data base. This approach is usually used to estimate the production or development cost.

b. Estimating by Analogy

The cost of a particular component, element, or system may be similar to an existing system. The cost of the existing system serves as the baseline, and adjustments for the differences yields the new cost. This approach is relatively simple and gives good accuracy for similar systems in the same type, but it is undesirable for high technology systems, such as electronics.

c. Engineering Estimates

This method, also called a "bottom-up" estimate or a "grass roots" method, is the construction of costs by estimating each component or equipment item. This is the most detailed technique with the best accuracy, but it requires a detailed program and product definitions. It also costs a lot of time and money.

d. Expert Opinion

This estimate is provided by the person, or persons, knowledgeable in a topic area. This may be biased, so it is not used when there is sufficient data, or when other methods are available.

3. Cost Estimation

A broad scope of data, system quality factors, such as MTBF, MTTR, MTBM, etc., manpower implications, and other operating and support cost data, are required to estimate LCC. As mentioned in the introduction, only a few cost data bases are available, and some data are classified, so an estimate of the LCC is out of the scope of this thesis. However, some cost estimates of a few similar cases will be done by analogy.

a. Development of New System

Even though there is sufficient technical and financial background, this alternative is the riskiest one. So, a very careful analysis is required for this alternative. However, most developing countries don't have enough historical data for the analyses. Table 5-9 shows R & D cost of some the U.S. Army artillery systems.

Table 5-9. R & D Cost of the U. S. Army Artillery Systems (in million dollars)

Fiscal Year	U.S. Army Deflator	M 198		M 119		M109 A6	
		Yearly	in 1995	Yearly	in 1995	Yearly	in 1995
1973	31.2	14.3	45.8				
1974	34.4	6.0	17.4				
1975	37.9	6.8	17.9				
1976	40.6	2.4	5.9				
1977	44.2	0.5	1.1				
1978	48.0	0.7	1.5				
1979	52.7	2.0	3.8				
1980	57.9						
1981	62.5	0.3	0.5				
1982	65.8						
1983	68.3						
1984	70.7					19.3	27.3
1985	72.8			9.1	12.5	26.9	37.0
1986	74.9			10.9	14.6	22.9	30.6
1987	77.2			13.1	17.0	35.3	45.7
1988	80.1			6.3	7.9	31.0	38.7
1989	83.3			1.6	1.9	25.4	30.5
1990	86.7					12.4	14.3
1991	89.7					8.8	9.8
1992	92.2						
Total		33.0	93.9	41.0	53.9	182.0	233.9

The M119 is a light towed 105 mm howitzer for the U. S. Army special forces, so it does satisfy the performance objectives mentioned in Chapter IV. The M198 is a 155 mm towed howitzer, so this is not proper either. As shown in the Table 4-3, the M109 A6 system is the closest system that satisfies the requirements. Similarly, the estimated cost of developing new

system will be approximately 233.9 million dollars in 1995 currency (estimate by analogy), and this does not exceed the budget limit. However, there is less technical background and fewer facilities in Korea than in the U. S. A. Consequently, for practical use, a more careful analyses is required for the costs, such as constructing new facilities, training personnel, and so on.

In addition to the R &D cost, procurement cost should be added to estimate the program acquisition cost for the alternatives. Again, the U. S. Army's M109A6 data will be used as an estimate. The U. S. Army has fielded this system since 1990. Table 5-10 shows the procurement cost data of the U. S. Army.

Table 5-10. M109A6 Cost Data (\$ in million)

Fiscal Year	Cost	Deflator	Cost (1995)	Accm. Cost	Unit	Accm. Unit	Mid-Point	Unit Cost
1990	75.5*	87.0	140.0**	140.0	44	44	22	3.18
1991	180.4	89.5	201.6	341.6	60	104	74	3.28
1992	131.6	91.9	143.2	484.8	60	164	134	2.96
1993	111.1	94.4	117.7	602.5	60	224	194	2.69
1994	155.3	97.1	160.0	762.5	170	394	309	1.94
1995	226.0	100.0	226.0	988.5	215	609	501.5	1.62
1996	220.2	102.9	213.8	1,202.3	215	824	716.5	1.46

* does not include long leads in 1988 (\$ 16.3 M) and in 1989 (\$ 27.8 M)

** includes long leads mentioned above (changed into 1995 dollar)

(Source : Paladin Program Office)

Note that the unit cost generally decreases as the accumulated quantity increases. The U. S. Army cost estimating reference book states that this decrease is a "Learning Phenomenon", and log-fit is a good model for this phenomenon. [Reference: Chapter 7, Cost Estimating Reference Book]. Figure 5-13 shows the unit cost versus accumulated units graphically (data from table 5-10 shown as '+'s), and the fitted equation (solid line) is,

$$y = 8.47 x^{-0.25} \text{ (million dollars / unit).....(12),}$$

where x is the accumulated unit quantity and y is the accumulated unit cost.

Note that the accuracy of this estimating technique depends upon the quantity to be procured. Assume that the quantity to be procured is large enough to follow this model.

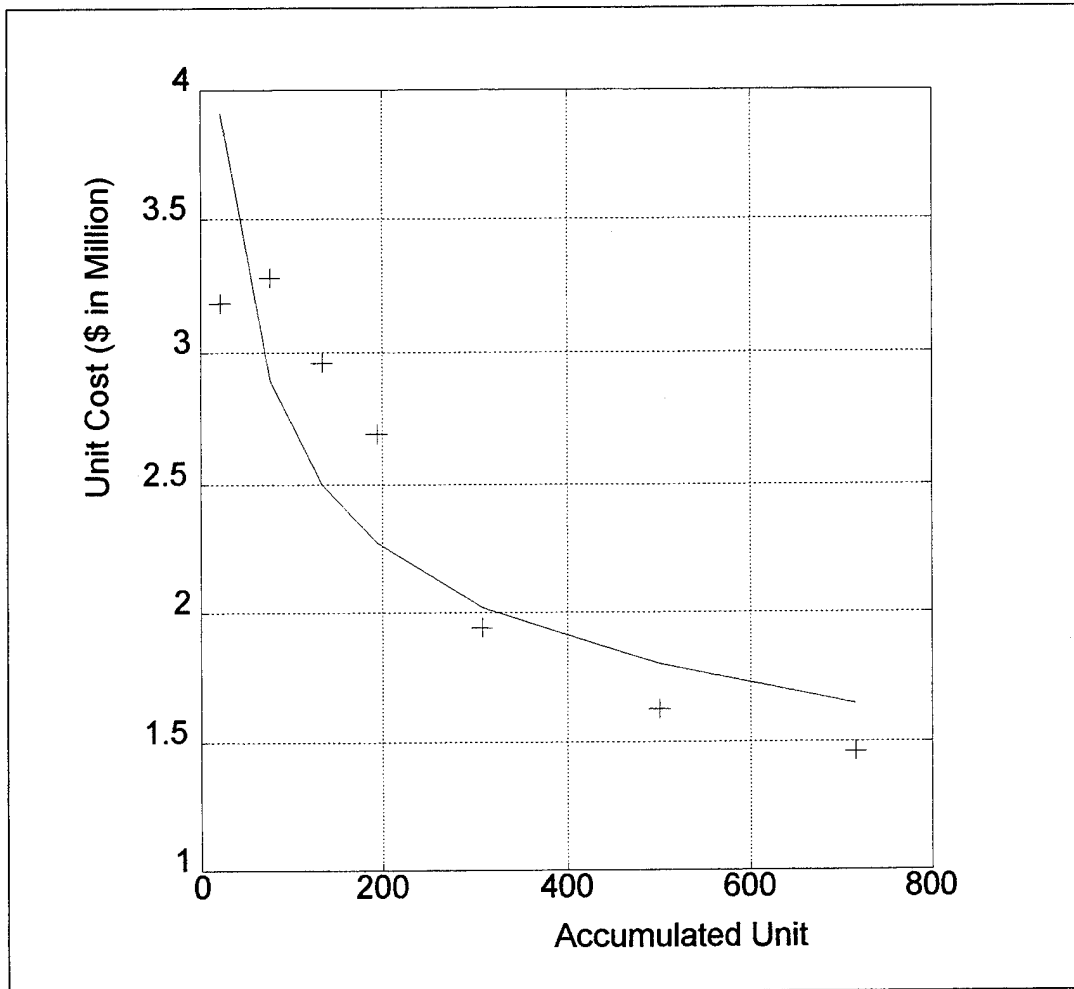

Figure 5-13. Estimate of the M109A6 Unit Cost.

The total cost (TC) for n units can be calculated by integrating the equation (12) from zero to n .

$$\begin{aligned}
 TC &= \int_0^n y \, dx = \int_0^n 8.47 x^{-0.25} \, dx \\
 &= \frac{8.47}{0.75} n^{0.75} \text{ (million dollars).....(13).}
 \end{aligned}$$

Therefore, the total program acquisition cost for n units will be the sum of equation (13) and \$ 233.9 million, the R & D cost estimated above,

$$\frac{8.47}{0.75} n^{0.75} + 233.9 \text{ (million dollars)} \dots\dots\dots(14).$$

b. Import from the Other Countries

Importing a weapon system is a continuous negotiating process. The cost of the weapon system can vary greatly. Among the selected alternatives, the company that builds the M109A6 system asks 1.44 million dollars per unit. Therefore, procurement cost for n units will be simple multiplication of n by 1.44,

$$1.44n \text{ (million dollars)} \dots\dots\dots(15).$$

The cost data for the PzH 2000 system, another alternative for importing, is not available. Assume that the price of this system 2 million dollars per unit for further analysis, then the procurement cost for n units will be,

$$2n \text{ (million dollars)} \dots\dots\dots(16).$$

D. TRADE-OFF ANALYSES

DoD instruction 5000.2-M states that the trade-off analyses describe equal-cost or equal-capability packages; that is, they display the implications of trading one set of controllable variables (such as schedule or performance) for another (such as cost).

Weighting of the parameters, ranking each alternative, and computing the overall grade is the most common method used to do a trade-off analysis. Finding the key parameters and proper weighting is critical to the results.

1. Uncertainty

The areas of uncertainties that are in the cost and effectiveness models should be examined. These analyses serve to highlight for the decision maker the areas in which uncertainties most likely affect the analyses and results.

2. Sensitivity

Sensitivity analyses show how the characteristics of the system affect military utility or effectiveness. The inherent uncertainty in estimating cost and/or effectiveness and in determining their impact should be analyzed.

3. Thresholds

Thresholds are the maximum cost and/or minimum acceptable performance that can be tolerated in a system.

E. DECISION CRITERIA

The criteria on which decisions are to be made should be clearly explained. Multiple criteria are always preferable to a single criterion.

In the artillery system, estimated cost, rate of fire, accuracy of fire, etc., could be the decision criteria, or criterion if only one is selected. As an example, assume that the cost is the single criterion among the three alternatives, home development, M109A6 system, and PzH 2000 system. Figure 5-14 is a plot of equations (14), (15), and (16) which shows the cost differences among alternatives as the quantity to be procured increases.

To find the intersection point between home development and M109A6, equate the two equations, (14) and (15), and numerically solve for n . The intersection value is approximately 4400 units. This means if the quantity to be procured is less than 4400, then importing the M109A6 costs less, otherwise home development costs less.

To find the intersection value between home development and PzH 2000, use equations (14) and (16). The result is $n = 1430$ units, which also means if the quantity to be procured is less than 1430, then importing PzH 2000 costs less, otherwise home development costs less.

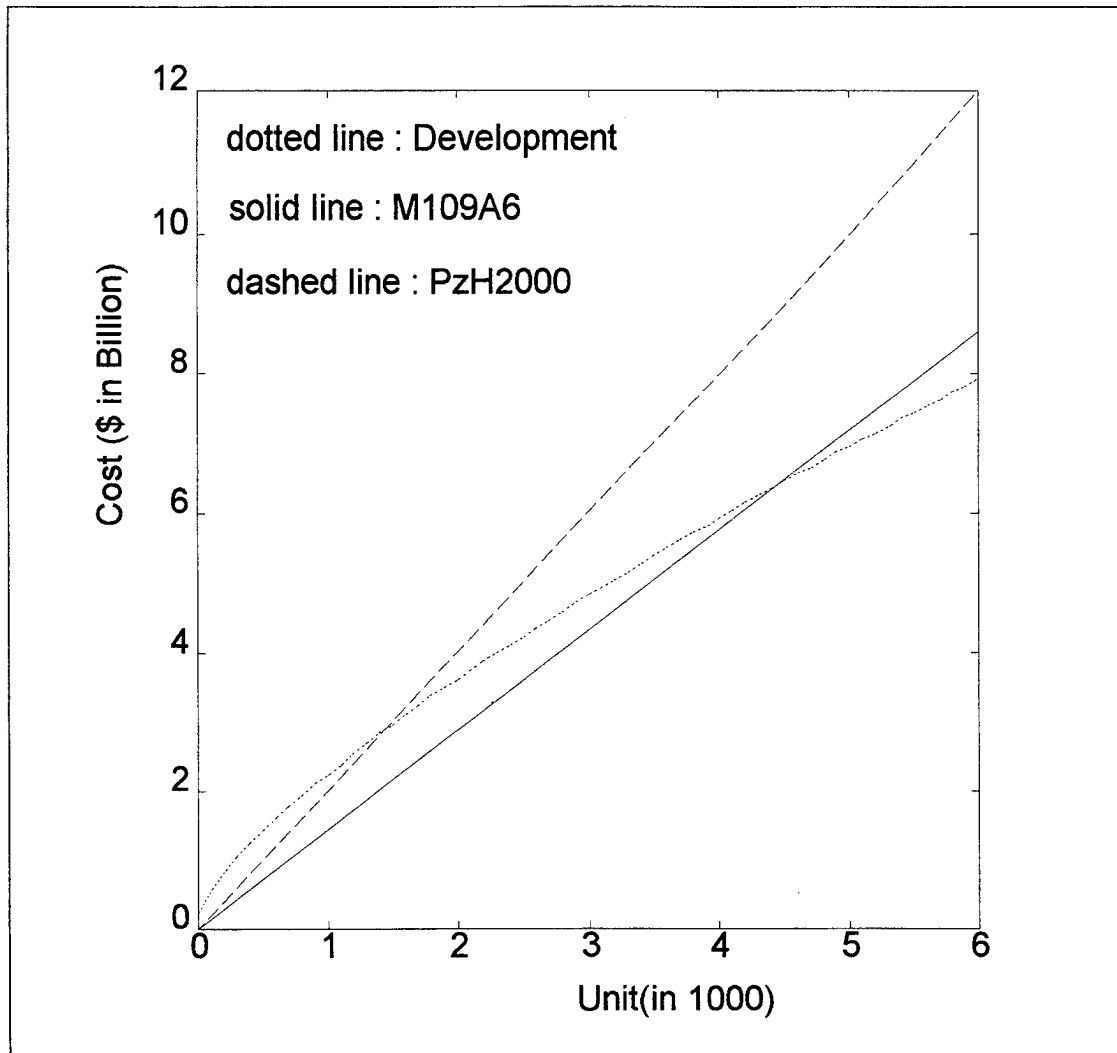

Figure 5-14. Cost Difference among the Alternatives

VI. SUMMARY OF THE RESULTS

This part of a COEA summarizes the findings that emerged from the analyses. Table 6-1 is the most popular format for the summary of the results.

In this thesis, the decision criteria consist of rate of fire, response time, range and cost. Each criterion is given a relative weight of 1.0. Assume the quantity to be procured is 1000 units, then the cost for three alternatives M109A6, PzH 2000, and home development will be, \$ 1.44 Billion (B), \$ 2.0 B, and \$ 2.24 B, respectively, or relatively 1.0, 0.72, and 0.65.

In the measures of the effectiveness, it is assumed that M109A6 can fire four-rounds-per-minute, and the other alternatives fire with ten-rounds-per-minute firing rate. The measured effectiveness of a ten-rounds-per-minute howitzer battery causes twice the damage in a dispersing target and 1.5 times the damage for the linearly moving target than the four-rounds-per-minute howitzer battery. Assume that there are equal portions of the target in the battlefield, stationary, dispersing, and linearly movement. Let the grade for the ten-rounds- per-minute howitzer be one. Then the grade for the four-rounds-per- minute will be,

$$\left(\frac{1}{3} \times 1\right) + \left(\frac{1}{3} \times 1\right) + \left(\frac{1}{3} \times \frac{2}{3}\right) = 0.72.$$

All of the alternatives have the same response time and satisfy the required range, so the grades for these characteristics will be unity.

Table 6-1. Summary of the Results

System Characteristics	Weight	Alternatives		
		M109A6	PzH 2000	Development
Rate of Fire	1.0	0.72	1.0	1.0
Response time	1.0	1.0	1.0	1.0
Range	1.0	1.0	1.0	1.0
Cost	1.0	1.0	0.72	0.65
Overall Grade		3.72	3.72	3.65

In the table 6-1, the weights on each criterion are equal. However, the results could be significantly changed if the weightings vary. Also Table 6-1 only shows the format and the result is not practical because of the limits mentioned before.

VII. CONCLUSIONS

One of the most important parts of the DoD management is the acquisition of weapon systems. The objective is how to find the most effective system with the least cost. There are many considerations and possible ways to achieve this goal which require considerable time and expense. The U. S. DoD instruction 5000 series shows one way to avoid these problems and difficulties and how to select the best alternative through a Cost and Operational Effectiveness Analysis (COEA). The COEA aides a decision maker by quantifying the various cost considerations and performance characteristics.

This thesis uses the procedure and format of COEA specified in DoD instruction 5000 series for the future artillery system in Korea. A computer simulation was developed to measure the effectiveness of each alternative. Even though many requirements and inputs are assumed and simplified (because of the time limit and sensitivity of the defense industry), this simulation can serve as an example for the acquisition management of future artillery systems.

APPENDIX A. COEA FORMAT

[This is a COEA format given in the attachment 1 (page 8-1-1 to 8-1-2), Part 8, DOD instruction 5000.2-M.]

COST AND OPERATIONAL EFFECTIVENESS ANALYSIS FOR PROGRAM TITLE

1. The Acquisition Issue

a. Need

Describes the deficiency or opportunity identified at Milestone 0, Concept Studies Approval in the Mission need Statement. Shows derivation from Defense Planning Guidance.

b. Threat

Describes projected enemy forces and tactics, including potential countermeasures. Cites sources for the projections and areas of uncertainty. References the System Threat Assessment Report.

c. Environment

Defines expected operating environment (terrain, weather, altitude, etc.). Notes Allied contributions where relevant. References the applicable sections of the Operational Requirements Document.

d. Constraints

Describes underlying assumptions regarding personnel, funding, and technical constraints. Shows effects, at the margin, of changes in the assumptions. References the applicable sections of the Mission Need Statement and the Operational Requirements Document.

e. Operational Concept

Summarizes the organizational and operational plan for the proposed system. Covers forces, equipment, doctrine, and tactics. References the applicable sections of the Operational Requirements Document.

2. Alternatives

a. Performance Objectives

Describes quantitatively the minimum acceptable operational requirements and objectives for the performance of the proposed concept or system. Shows the impact of changes at the margin in performance and mission satisfaction. References the applicable sections of the Operational Requirements Document.

b. Description of Alternatives

Describes the alternatives investigated in the analysis.

3. Analysis of Alternatives

a. Models

Identifies the models used in the analysis and discusses the reasons for their selection. Documents the input data and assumptions

b. Measures of Effectiveness

Identifies the measures of effectiveness used; explains the rationale for their selection. Presents results for the individual alternatives.

c. Costs

Shows life cycle and force costs for each alternative in the constant and current dollars. Displays sunk costs (if provided) separately. Shows manpower implications and program and budget status.

d. Trade-Off Analysis

Shows uncertainties in the cost and effectiveness estimates for each alternative. Analyzes sensitivity of the results to changes in the performance and schedule. Identifies possible cost and performance thresholds for each alternative.

e. Decision Criteria

Suggests criteria for selecting among the alternatives.

4. Summary of Results

Summarizes the major findings and analysis. Highlights factors affecting the acceptability of the alternatives, both individually and in relation to one another.

APPENDIX B. 'C' PROGRAM FOR THE PROJECTILE TRAJECTORY

```

/*****
/*   ARTILLERY SIMULATION           */
/*   1 Round Trajectory             */
*****/

# include <stdio.h>
# include <math.h>
main()
{
float r1,r2,max,x,y,y0,z,g,Vx,Vy,Vz,dt,pi;
float c,rho,crA,m,v0,range,el,d,A,t,v,dtheta,dVx,dVy,dVz;
float theta0,thi0;
int seed,i,j,k;

FILE *fp
fp=fopen("tra.data","w");

pi=3.141592654;
g=9.8;
d=155.0/1000;
c=0.2914;
A=pi*d*d/4;
m=43.1;           /* projectile mass in kg      */
el=451.1;        /* Data of gun and target    */
v0=474;          /* initial velocity of projectile */
theta0=(2*pi*el)/6400; /* vertical angle of gun in radian */
dtheta=0.0;      /* dispersion of gun          */
thi0=0.0;
range=10000.0;

fprintf(fp,"\n*** Trajectory Data ***\n");
fprintf(fp,"Time(sec)      x          y          z\n");
dt=0.05;

```

```

max=pow(2.0,31.0)-1.0;
seed=1;
srandom(seed);
x=0.0; y=0.0; z=0.0; t=0;
        /* Initial velocity component of each direction */
Vx=v0*sin(theta0)*sin(thi0);
Vy=v0*cos(theta0);
Vz=v0*sin(theta0)*cos(thi0);
r1=random()/max;
r2=random()/max;        /* random component */
                        /* of velocity */
dVx=v0*dtheta*sqrt(-2.0*log(r1))*sin(2.0*pi*r2)/sqrt(2.0);
dVz=v0*dtheta*sqrt(-2.0*log(r1))*cos(2.0*pi*r2)/sqrt(2.0);
Vz=Vz+dVz;
Vx=Vx+dVx;
    while (z>=0.0)
    {
        zz=z/1000;
        rho=1.2263-0.1189*zz+0.0046*zz*zz-0.0001*zz*zz*zz;
        crA=c*rho*A/(2*m);
        v=sqrt(Vx*Vx+Vy*Vy+Vz*Vz);
        Vz=Vz-(g+crA*v*Vz)*dt;
        Vx=Vx-(crA*v*Vx)*dt;
        Vy=Vy-(crA*v*Vy)*dt;
        x=x+Vx*dt;
        y=y+Vy*dt;
        z=z+Vz*dt;
        t=t+dt;
        fprintf(fp,"%f\t%f\t%f\t%f\n",t,x,y,z);
    }
close(fp);
}

```

Trajectories

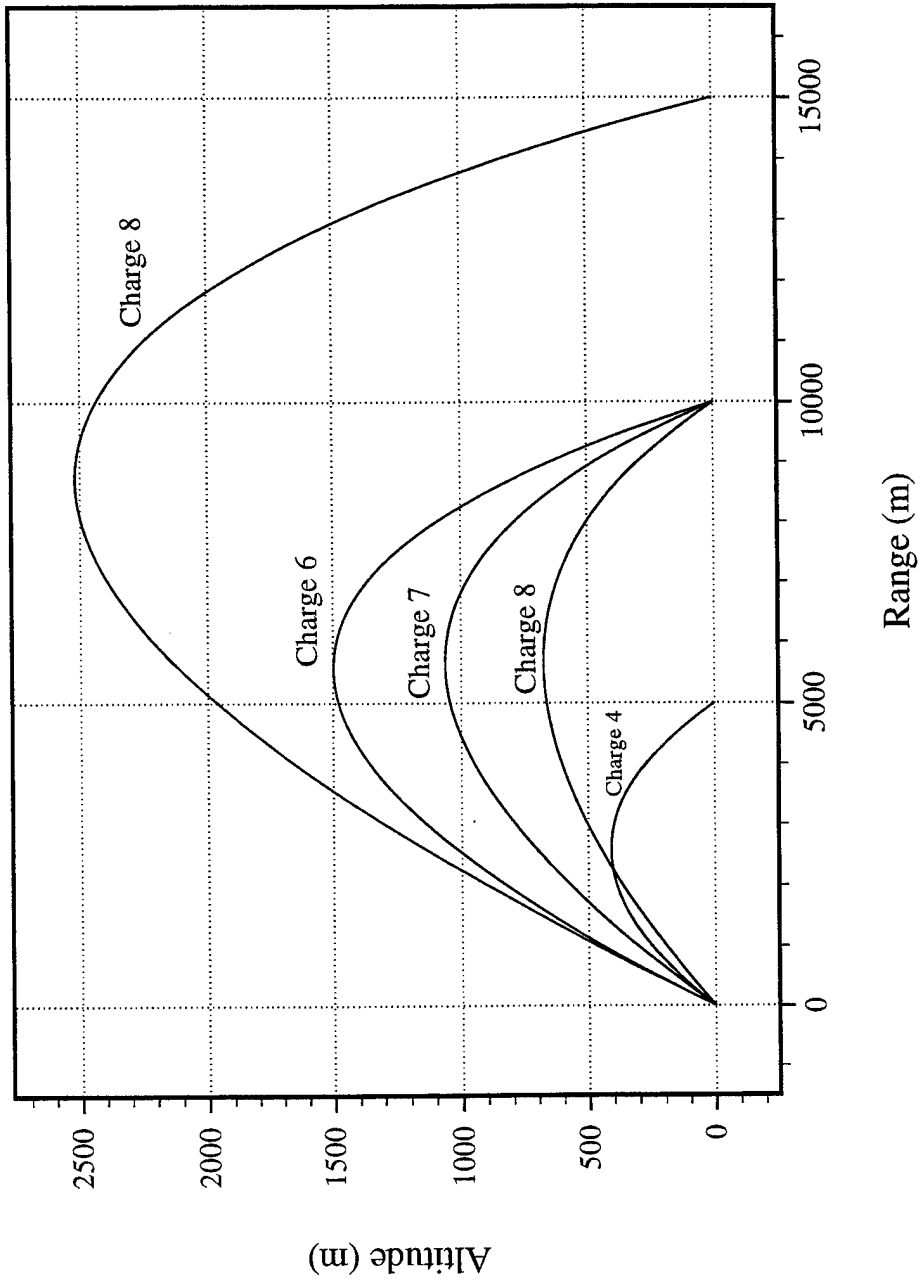

APPENDIX D. 'C' PROGRAM FOR THE CHECKING PROBABLE ERROR

```
/*
*****
/*      Probable Error      */
*****
*/

# include <stdio.h>
# include <math.h>
main()
{
float r1,r2,r3,r4,max,x,y,y0,z,zz,g,Vx,Vy,Vz,dt,ti,pi;
float c,rho,crA,m,mv,dv0,v0,range,el,d,A,t,v,dtheta,dVx,dVz;
float theta0,thi0,pe,sum_x,sum_y,ax,ay;
int seed,h,i,j,s,k,nr,nr0;
float rdata[100000],ddata[100000],data[100000],sort;

FILE *fp;
fp=fopen("pe.15c8","w");
fprintf(fp,"dv0 = %8.4f\t dtheta =%7.3f\n",dv0,dtheta);

pi=3.141592654;
g=9.8;
d=155.0/1000;
c=0.3062;
A=pi*d*d/4;
m=43.1;
el=455.9;          /*      Data of gun and target      */
v0=684;           /* initial velocity of projectile */
theta0=(2*pi*el)/6400; /* vertical angle of gun in radian */
dtheta=0.00125;
dv0=2.1;          /* Standard Deviation of Muzzle Velocity */
thi0=0.0;
range=15000.0;

dt=0.05;
nr=100;
```

```

nr0=0;
max=pow(2.0,31.0)-1.0;
seed=1;
srandom(seed);

sum_x=0; sum_y=0;

while (nr<=10000)
/*while (dtheta<=0.05) */
{
for (k=nr0;k<nr;k++)
{ x=0.0; y=0.0; z=0.0; t=0;
  ddata[k]=0;    rdata[k]=0;
  r1=random()/max;
  r2=random()/max;
  r3=random()/max;
  r4=random()/max;

  mv=v0+dv0*sqrt(-2.0*log(r1))*cos(2.0*pi*r2);
  Vx=mv*sin(theta0)*sin(thi0); /* Initial velocity component */
  Vy=mv*cos(theta0);          /* of each direction */
  Vz=mv*sin(theta0)*cos(thi0);
                                /* random component of velocity */
  dVx=mv*dtheta*sqrt(-2.0*log(r1))*sin(2.0*pi*r2)/sqrt(2.0);
  dVz=mv*dtheta*sqrt(-2.0*log(r1))*cos(2.0*pi*r2)/sqrt(2.0);
  Vx=Vx+dVx;
  Vz=Vz+dVz;

while (z>=0.0)
{
  zz=z/1000;
  rho=1.2263-0.1189*zz+0.0046*zz*zz-0.0001*zz*zz*zz;
  crA=c*rho*A/(2*m);
  v=sqrt(Vx*Vx+Vy*Vy+Vz*Vz);
  Vx=Vx-(crA*v*Vx)*dt;
  Vy=Vy-(crA*v*Vy)*dt;

```

```

    Vz=Vz-(g+crA*v*Vz)*dt;
    x=x+Vx*dt;
    y=y+Vy*dt;
    z=z+Vz*dt;
    t=t+dt;
}
ti=(Vz*dt-z)/Vz;
x=x+Vx*(ti-dt);
y=y+Vy*(ti-dt);
z=z+Vz*(ti-dt);

sum_x=sum_x+x;  sum_y=sum_y+y;
ddata[k]=x;    rdata[k]=y;
}
ax=sum_x/nr; ay=sum_y/nr; /* mean point of impact */
/* determine provable error */
s=0;
while(s<=1) /* s=0 : range, s=1 : deflection */
{
    for (i=1;i<=nr;i=i+1) /* read data */
    {
        if (s==0) data[i]=rdata[i]-ay;
        else data[i]=ddata[i]-ax;
        if (data[i]<0) data[i]=-1*data[i];
    }
    for (i=2;i<=nr;i=i+1)
    {
        sort=data[i];
        j=i;
        while (data[j-1]>sort)
        { data[j]=data[j-1];
          j=j-1;
        }
        data[j]=sort;
    }
}
h=(int)(nr/2);

```

```
    pe=(data[h]+data[h+1])/2;
    fprintf(fp,"%8d\t%7.3f\t",nr,pe);
    s=s+1;
}
/* dtheta=dtheta+0.001;*/
nr0=nr;
nr=nr+100;
fprintf(fp,"\n");
}
fprintf(fp,"MPI : direction %8.2f  range %8.2f\t",ax,ay);
close(fp);
}
```

APPENDIX E. PROBABLE ERRORS VERSUS ROUNDS FIRED

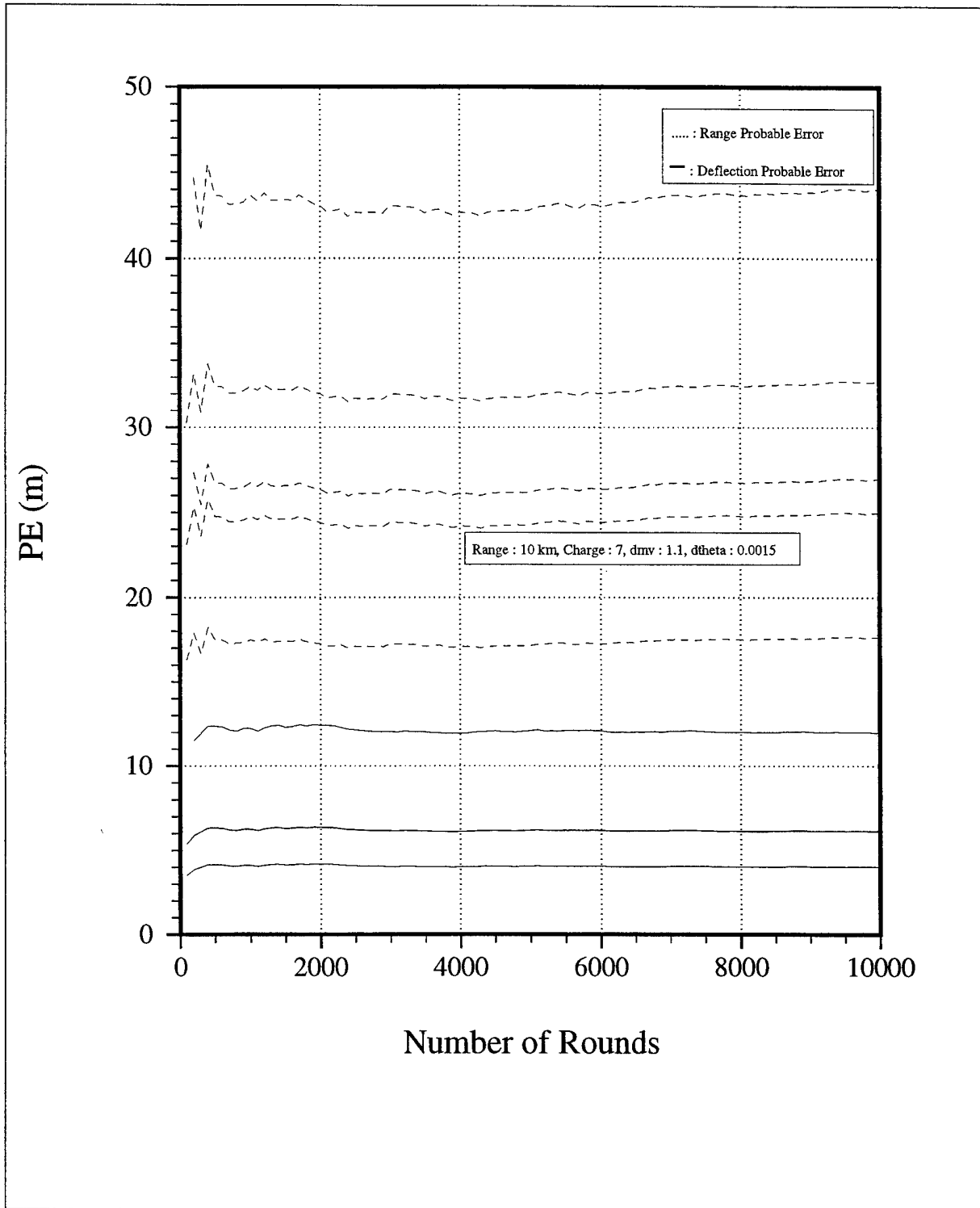

APPENDIX F. PROBABLE ERRORS WITH VELOCITY AND ANGLE CHANGES

The followings are the outputs, the ratio of measured PEs to the given PEs in the firing table, with the different standard deviations of muzzle velocity and initial angle. Determine the dv_0 , the standard deviation of muzzle velocity, and $d\theta$, the standard deviation of initial elevation, such that combination makes the ratio equal to, or closest to one, which are highlighted in the following tables.

1. Range : 5 km, Charge 4, Given range probable error (PE-R) : 18 m and deflection probable error (PE-R) : 4 m.

dtheta	dv0 =0.1		dv0 =0.2		dv0 =0.3	
	PE-R	PE-D	PE-R	PE-D	PE-R	PE-D
0.0011	0.55	0.68	0.64	0.69	0.75	0.69
0.0012	0.58	0.74	0.67	0.75	0.77	0.74
0.0013	0.61	0.82	0.72	0.82	0.82	0.82
0.0014	0.67	0.87	0.76	0.88	0.88	0.87
0.0015	0.71	0.92	0.79	0.92	0.90	0.93
0.0016	0.74	0.99	0.84	1.01	0.96	1.00
0.0017	0.77	1.06	0.88	1.07	1.02	1.07
0.0018	0.84	1.13	0.92	1.12	1.06	1.13
0.0019	0.85	1.20	0.97	1.16	1.05	1.22
0.0020	0.88	1.23	1.00	1.25	1.12	1.26

dtheta	dv0 =0.4		dv0 =0.5		dv0 =0.6	
	PE-R	PE-D	PE-R	PE-D	PE-R	PE-D
0.0011	0.86	0.7	0.96	0.68	1.06	0.68
0.0012	0.89	0.77	1.00	0.75	1.10	0.75
0.0013	0.94	0.81	1.05	0.82	1.14	0.82
0.0014	0.96	0.87	1.08	0.86	1.19	0.88
0.0015	1.02	0.96	1.11	0.93	1.20	0.93
0.0016	1.05	0.99	1.17	1.01	1.28	0.99
0.0017	1.13	1.06	1.18	1.06	1.29	1.06
0.0018	1.14	1.12	1.26	1.14	1.37	1.12
0.0019	1.18	1.19	1.30	1.16	1.36	1.15
0.0020	1.22	1.25	1.31	1.26	1.4	1.24

2. Range : 10 km, Charge 6, Given range probable error (PE-R) : 27 m and deflection probable error (PE-D) : 6 m.

dtheta	dv0 = 0.8		dv0 = 0.9		dv0 = 1.0	
	PE-R	PE-D	PE-R	PE-D	PE-R	PE-D
0.0005	0.68	0.44	0.73	0.45	0.81	0.44
0.0006	0.69	0.54	0.76	0.52	0.82	0.52
0.0007	0.71	0.63	0.79	0.61	0.85	0.62
0.0008	0.74	0.70	0.81	0.71	0.87	0.71
0.0009	0.75	0.79	0.84	0.78	0.91	0.79
0.0010	0.80	0.90	0.85	0.87	0.91	0.87
0.0011	0.81	0.96	0.90	0.97	0.96	0.96
0.0012	0.88	1.05	0.90	1.06	0.97	1.05
0.0013	0.88	1.14	0.96	1.17	1.02	1.15
0.0014	0.90	1.23	0.98	1.21	1.02	1.20
0.0015	0.93	1.32	0.99	1.34	1.04	1.31

dtheta	dv0 = 1.1		dv0 = 1.2		dv0 = 1.3	
	PE-R	PE-D	PE-R	PE-D	PE-R	PE-D
0.0005	0.87	0.44	0.92	0.44	0.98	0.44
0.0006	0.88	0.52	0.96	0.54	1.03	0.54
0.0007	0.92	0.61	0.99	0.63	1.06	0.62
0.0008	0.93	0.70	1.00	0.70	1.10	0.71
0.0009	0.97	0.79	1.05	0.80	1.09	0.79
0.0010	1.00	0.88	1.07	0.87	1.13	0.88
0.0011	1.00	0.96	1.07	0.96	1.17	0.98
0.0012	1.05	1.07	1.11	1.06	1.19	1.06
0.0013	1.06	1.14	1.14	1.15	1.20	1.14
0.0014	1.10	1.21	1.17	1.25	1.22	1.27
0.0015	1.10	1.28	1.19	1.31	1.29	1.32

3. Range : 10 km, Charge 7, Given range probable error (PE-R) : 25 m and deflection probable error (PE-D) : 5 m.

dtheta	dv0 = 0.9		dv0 = 1.0		dv0 = 1.1	
	PE-R	PE-D	PE-R	PE-D	PE-R	PE-D
0.0005	0.69	0.50	0.77	0.50	0.81	0.50
0.0006	0.72	0.60	0.79	0.60	0.84	0.60
0.0007	0.76	0.70	0.82	0.70	0.88	0.70
0.0008	0.78	0.80	0.86	0.80	0.91	0.80
0.0009	0.86	0.90	0.91	0.90	0.96	0.91
0.0010	0.88	1.02	0.92	0.98	0.97	1.00
0.0011	0.90	1.14	0.96	1.12	1.04	1.12
0.0012	0.95	1.20	0.99	1.23	1.08	1.18
0.0013	0.97	1.31	1.05	1.31	1.09	1.32
0.0014	1.03	1.44	1.07	1.44	1.13	1.39
0.0015	1.05	1.49	1.12	1.48	1.18	1.49

dtheta	dv0 = 1.1		dv0 = 1.2		dv0 = 1.3	
	PE-R	PE-D	PE-R	PE-D	PE-R	PE-D
0.0005	0.86	0.50	0.93	0.50	0.96	0.50
0.0006	0.89	0.60	0.94	0.59	1.01	0.60
0.0007	0.93	0.70	0.98	0.70	1.05	0.71
0.0008	0.98	0.81	1.04	0.81	1.06	0.80
0.0009	1.00	0.89	1.06	0.89	1.12	0.92
0.0010	1.04	1.00	1.10	1.02	1.15	1.00
0.0011	1.07	1.11	1.14	1.14	1.20	1.09
0.0012	1.12	1.21	1.17	1.17	1.20	1.17
0.0013	1.13	1.30	1.22	1.31	1.25	1.32
0.0014	1.20	1.39	1.23	1.38	1.31	1.39
0.0015	1.22	1.50	1.29	1.49	1.35	1.46

4. Range : 10 km, Charge 8, Given range probable error (PE-R) : 33 m and deflection probable error (PE-D) : 6 m.

dtheta	dv0 =1.1		dv0 =1.2		dv0 =1.3	
	PE-R	PE-D	PE-R	PE-D	PE-R	PE-D
0.0005	0.61	0.41	0.63	0.40	0.66	0.41
0.0006	0.64	0.48	0.68	0.49	0.72	0.49
0.0007	0.69	0.56	0.73	0.58	0.77	0.57
0.0008	0.72	0.65	0.76	0.65	0.82	0.65
0.0009	0.78	0.73	0.82	0.74	0.84	0.72
0.0010	0.82	0.82	0.86	0.80	0.89	0.81
0.0011	0.85	0.88	0.88	0.89	0.95	0.90
0.0012	0.91	0.99	0.93	0.98	0.98	0.98
0.0013	0.94	1.05	0.98	1.06	1.01	1.06
0.0014	0.99	1.12	1.03	1.15	1.05	1.17
0.0015	1.01	1.18	1.07	1.21	1.13	1.22

dtheta	dv0 =1.4		dv0 =1.5		dv0 =1.6	
	PE-R	PE-D	PE-R	PE-D	PE-R	PE-D
0.0005	0.72	0.41	0.75	0.41	0.78	0.40
0.0006	0.74	0.49	0.78	0.49	0.81	0.48
0.0007	0.80	0.57	0.81	0.57	0.86	0.57
0.0008	0.84	0.66	0.88	0.66	0.91	0.64
0.0009	0.88	0.71	0.91	0.74	0.95	0.72
0.0010	0.92	0.82	0.99	0.80	0.99	0.82
0.0011	0.95	0.90	1.01	0.88	1.05	0.89
0.0012	1.02	0.98	1.04	0.96	1.08	0.96
0.0013	1.06	1.05	1.08	1.07	1.15	1.06
0.0014	1.10	1.15	1.11	1.12	1.17	1.15
0.0015	1.14	1.22	1.15	1.21	1.21	1.22

5. Range : 15 km, Charge 8, Given range probable error (PE-R) : 44 m and deflection probable error (PE-D) : 10 m.

dtheta	dv0 =1.9		dv0 =2.0		dv0 =2.1	
	PE-R	PE-D	PE-R	PE-D	PE-R	PE-D
0.0005	0.79	0.40	0.82	0.40	0.85	0.39
0	0.79	0.48	0.83	0.48	0.86	0.47
0.0007	0.82	0.55	0.84	0.56	0.89	0.55
0.0008	0.84	0.64	0.89	0.64	0.91	0.62
0.0009	0.86	0.69	0.89	0.72	0.94	0.71
0.0010	0.88	0.80	0.95	0.78	0.95	0.80
0.0011	0.88	0.88	0.94	0.87	0.99	0.87
0.0012	0.93	0.96	0.95	0.93	1.00	0.94
0.0013	0.95	1.03	0.97	1.04	1.04	1.04
0.0014	0.97	1.12	0.98	1.09	1.04	1.12
0.0015	0.99	1.19	1.01	1.18	1.06	1.19

dtheta	dv0 =2.1		dv0 =2.3		dv0 =2.4	
	PE-R	PE-D	PE-R	PE-D	PE-R	PE-D
0.0005	0.91	0.39	0.92	0.40	0.95	0.40
0.0006	0.90	0.47	0.95	0.48	0.97	0.48
0.0007	0.92	0.56	0.97	0.56	0.99	0.56
0.0008	0.95	0.65	0.98	0.64	1.00	0.63
0.0009	0.96	0.72	1.00	0.71	1.05	0.72
0.001	1.00	0.81	1.01	0.80	1.09	0.80
0.0011	1.04	0.87	1.05	0.86	1.08	0.86
0.0012	1.03	0.95	1.08	0.95	1.10	0.97
0.0013	1.06	1.03	1.11	1.01	1.13	1.04
0.0014	1.08	1.10	1.12	1.12	1.14	1.14
0.0015	1.09	1.18	1.15	1.19	1.16	1.16

APPENDIX G. SAMPLE PLOT OF HIT DISTRIBUTION

Example plot of 1000 rounds hit distribution at the range of 15 km with charge 8.
(PE-R : 44 m, PE-D : 10 m, Dotted line : 4 PEs)

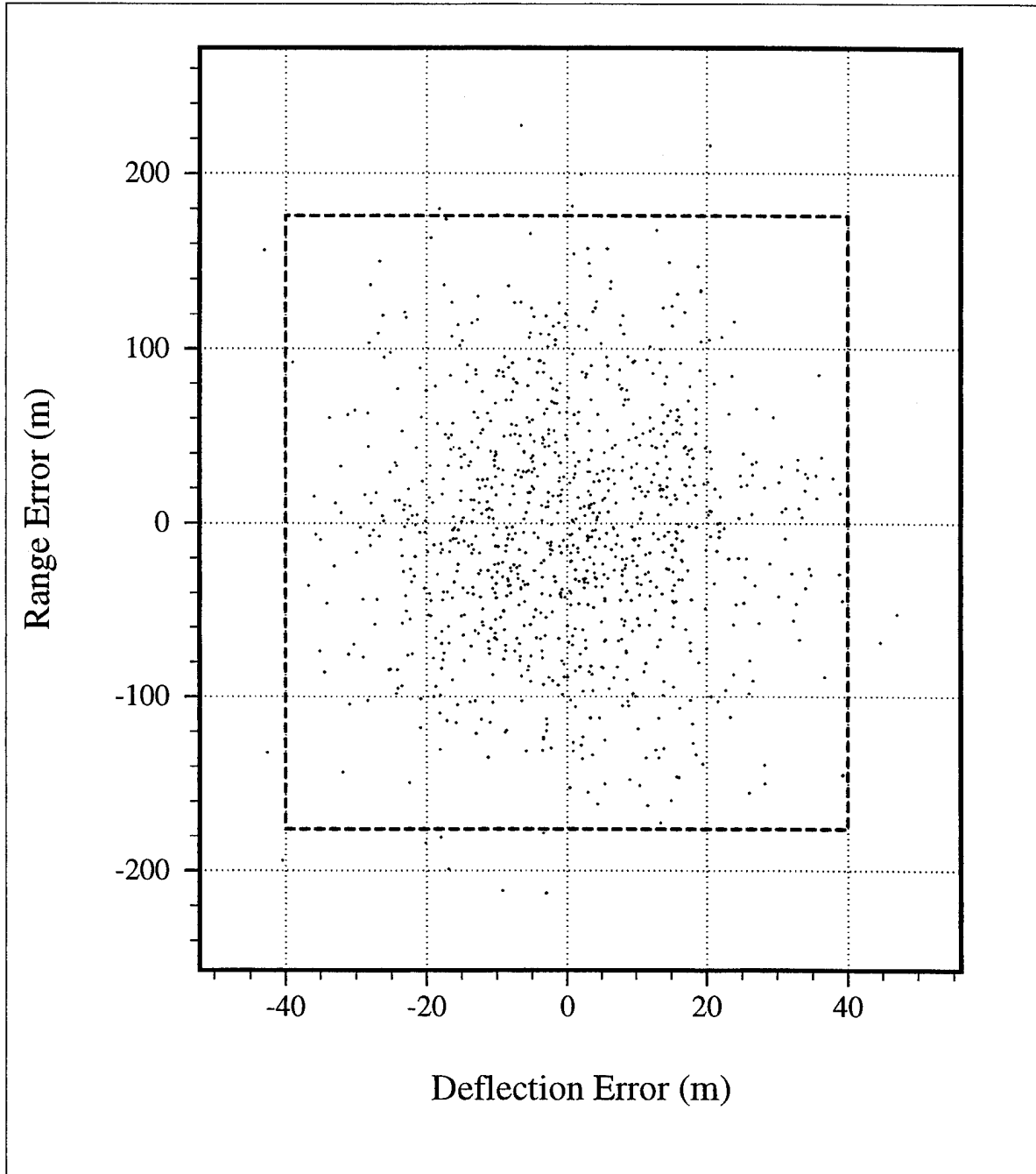

APPENDIX H. 'C' PROGRAM FOR MULTIPLE FIRING AGAINST AREA TARGETS

```

/*****/
/*  ARTILLERY SIMULATION          */
/*  1 X 1 cell  Damage            */
/*  Moving Target                 */
/*****/

# include <stdio.h>
# include <math.h>
main()
{
float r1,r2,r3,r4,max,x,y,x0,z,zz,g,v,mv,dmv,v0,Vx,Vy,Vz,dVx,dVz;
float c,rho,crA,m,range,el,d,A,tarw,tarl,R,damage,t,dt,ti,pi;
float theta0,dtheta,thi0,hit,nh,ns,hratio,cratio,hper,cper,tv,rd;
int seed,i,j,k,tj,tjmin,tjmax,tk,tkmin,tkmax,num_tar,nr,n_gun,
    ex,n,nf;
int ts[1000][500],cjmin,cjmax,ckmin,ckmax,hjmin,hjmax,hkmin,
    hkmax,nrmax;
float sumnh,avenh,sumhit,avehit,tw_max,tl_max,tw_new,tl_new;

FILE *fp;
fp=fopen("10kc8.data","w");
fprintf(fp,"\n***  Result of Simulation  ***\n");
fprintf(fp," tar-vel  nr  tarw  tarl  ave-cell  cum-damage\n");

pi=3.141592654;
g=9.8;
d=155.0/1000; /*          Parameters of Projectile          */
c=0.3181;
A=pi*d*d/4;
m=43.1;

/*          Firing Data          */
el=208.4; /*  Elevation in mil          */
v0=684.0; /*  Projectile Muzzle Velocity  */
theta0=(2*pi*el)/6400; /*  Elevation in Radian          */

```

```

dtheta=0.00125;          /* Dispersion of gun          */
dv0=1.35;
thi0=0.0;
range=10000.0;

nrmax=10;
n_gun=6;
dt=0.05;
max=pow(2.0,31.0)-1.0;

                                /**** Target Data      ****/
tarw=300.0; tarl=50.0;        /* Initial Target size      */
tw_max=500.0; tl_max=250.0;  /* Moving Target size (maximum) */

tjmax=(int)(tw_max);
tkmin=(int)(range-0.5*tl_max);
tkmax=(int)(range+0.5*tl_max);

seed=1;
srandom(seed);

nf=1;
while (nf<=4)
{
    fprintf(fp,"Number of Firing Unit : %d. \n",nf);

    tv=0;
    while (tv<=100)
    {

        damage=0;
        for (nr=1;nr<=nrmax;nr++)
        {
            sumhit=0;
            i=nr;
            tw_new=tarw+2.0*tv*(i-1); if (tw_new>=tw_max) tw_new=tw_max;
            tl_new=tarl+2.0*tv*(i-1); if (tl_new>=tl_max) tl_new=tl_max;

```

```

num_tar=tw_new*tl_new;      /* Number of target cells */
cjmin=(int)(0.5*(tw_max-tarw)-tv*(i-1)); if (cjmin<=0) cjmin=0;
cjmax=(int)(0.5*(tw_max+tarw)+tv*(i-1));
        if (cjmax>=tjmax) cjmax=tjmax;
ckmin=(int)(range-0.5*tl_new);
        if (ckmin<=tkmin) ckmin=tkmin;
ckmax=(int)(range+0.5*tl_new);
        if (ckmax>=tkmax) ckmax=tkmax;
for (ex=1;ex<=500;ex++)
{
    hit=0;
    for (tj=0;tj<=tjmax-1;tj++)
        for (tk=tkmin;tk<=tkmax-1;tk++)
            ts[tj][tk]=0;
for (n=1;n<=nf; n++)
{
    for (k=1;k<=n_gun; k++)
    {
        x0=tarw/(2*n_gun)+(tarw/n_gun)*(k-1);
            /* Correction for Gun Position */
        x=x0; y=0.0; z=0.0; t=0;
        r1=random()/max;
        r2=random()/max;
        r3=random()/max;
        r4=random()/max;
        mv=v0+dv0*sqrt(-2.0*log(r1))*cos(2.0*pi*r2);
            /* Initial velocity component of each direction */
        Vx=mv*sin(theta0)*sin(thi0);
        Vy=mv*cos(theta0);
        Vz=mv*sin(theta0)*cos(thi0);
            /* random component of velocity */
        dVx=mv*dtheta*sqrt(-2.0*log(r1))*sin(2.0*pi*r2)/sqrt(2.0);
        dVz=mv*dtheta*sqrt(-2.0*log(r1))*cos(2.0*pi*r2)/sqrt(2.0);
        Vz=Vz+dVz;
        Vx=Vx+dVx;
        while (z>=0.0)

```

```

{
    zz=z/1000;
    rho=1.2263-0.1189*zz+0.0046*zz*zz-0.0001*zz*zz*zz;
    crA=c*rho*A/(2*m);
    v=sqrt(Vx*Vx+Vy*Vy+Vz*Vz);
    Vz=Vz-(g+crA*v*Vz)*dt;
    Vy=Vy-(crA*v*Vy)*dt;
    Vx=Vx-(crA*v*Vx)*dt;
    x=x+Vx*dt;
    y=y+Vy*dt;
    z=z+Vz*dt;
    t=t+dt;
}
ti=(Vz*dt-z)/Vz;
x=x+Vx*(ti-dt);
y=y+Vy*(ti-dt);
z=z+Vz*(ti-dt);

hkmin=(int)(y-25.0);
hkmax=(int)(y+25.0);
if (hkmin<=ckmin) hkmin=ckmin;
if (hkmax>=ckmax) hkmax=ckmax;
for (tk=hkmin;tk<=hkmax-1;tk++)
{
    rd=25.0*25.0-(tk+0.5-y)*(tk+0.5-y); if (rd<=0) rd=0;
    hjmin=(int)(x-sqrt(rd)+0.5*(tw_max-tarw));
    hjmax=(int)(x+sqrt(rd)+0.5*(tw_max-tarw));
    if (hjmin<=0) hjmin=0;
    if (hjmax>=cjmax) hjmax=cjmax;
        for (tj=hjmin;tj<=hjmax;tj++)
            ts[tj][tk]=ts[tj][tk]+1;
}
}
}
for (tj=cjmin;tj<=cjmax-1;tj++)
{
    for (tk=ckmin;tk<=ckmax-1;tk++)
        {

```

```

                if ( ts[tj][tk]!=0)   hit=hit+1;
                    ts[tj][tk]=0;
            }
        }
cratio=hit/num_tar;/* hit : Number of cells at least one hit */
cper=cratio*100;
sumhit=sumhit+cratio;
avehit=sumhit/ex;
    }
damage=damage+(1-damage)*avehit;
fprintf(fp,"%6.2f %5d %5.0f %5.0f %7.2f %7.2f \n",
        tv,nr,tw_new,tl_new,avehit,damage);
    }
    if (tv<=12.5) tv=tv+2.5;
        else if (tv<=25) tv=tv+5;
            else tv=tv+10;
    }
nf=nf+1;
}
close(fp);
close(fp1);
}

```

APPENDIX I. AVERAGE DAMAGE VERSUS NUMBER OF EXPERIMENT

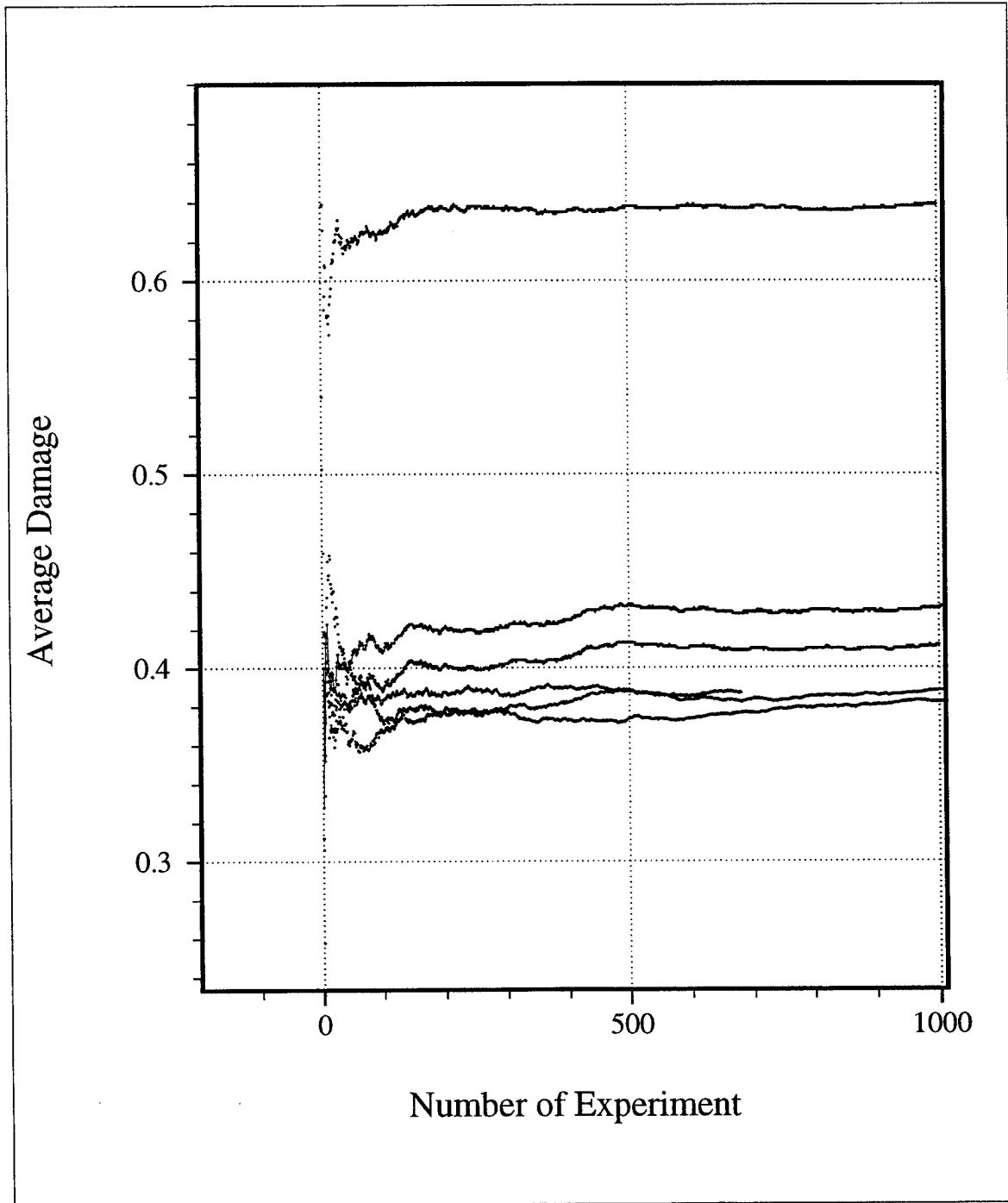

APPENDIX J. SAMPLE OUTPUT

This is outputs of the computer simulation with different target speed. The numbers in the speed column represent displacement over the time interval between the next volley. In other words, the damage with speed 5 can be an output of the target speed of 5 m/min with one-round-per-minute howitzer, an output of the target speed of 20 m/min with four-rounds-per-minute howitzer, or an output of the target speed of 50 m/min with ten-rounds-per-minute howitzer.

1. Output of Dispersing Target

Firing Unit : 1								
Speed (m/ min)	Rounds	Target Size		Damage at Range(Charge)				
		Length (m)	Width (m)	5 km (4)	10 km (6)	10 km (7)	10 km (8)	15 km (8)
0	1	300	50	0.56	0.42	0.46	0.39	0.28
0	2	300	50	0.81	0.66	0.70	0.62	0.47
0	3	300	50	0.91	0.80	0.84	0.77	0.61
0	4	300	50	0.96	0.88	0.91	0.86	0.72
0	5	300	50	0.98	0.93	0.95	0.91	0.80
0	6	300	50	0.99	0.96	0.97	0.95	0.85
0	7	300	50	1.00	0.98	0.99	0.97	0.89
0	8	300	50	1.00	0.99	0.99	0.98	0.92
0	9	300	50	1.00	0.99	1.00	0.99	0.94
0	10	300	50	1.00	1.00	1.00	0.99	0.96
5	1	300	50	0.56	0.42	0.46	0.39	0.28
5	2	310	60	0.78	0.65	0.69	0.61	0.47
5	3	320	70	0.88	0.78	0.81	0.74	0.61
5	4	330	80	0.93	0.85	0.88	0.83	0.70
5	5	340	90	0.96	0.90	0.92	0.88	0.77
5	6	350	100	0.97	0.93	0.94	0.91	0.82
5	7	360	110	0.98	0.95	0.96	0.93	0.86
5	8	370	120	0.98	0.96	0.97	0.95	0.89
5	9	380	130	0.99	0.97	0.98	0.96	0.91
5	10	390	140	0.99	0.98	0.98	0.97	0.92
10	1	300	50	0.56	0.42	0.45	0.38	0.27
10	2	320	70	0.76	0.63	0.67	0.59	0.46
10	3	340	90	0.85	0.75	0.78	0.72	0.59
10	4	360	110	0.89	0.82	0.84	0.79	0.67
10	5	380	130	0.92	0.86	0.88	0.83	0.73

10	6	400	150	0.93	0.88	0.90	0.87	0.78
10	7	420	170	0.95	0.9	0.92	0.89	0.81
10	8	440	190	0.95	0.92	0.93	0.9	0.83
10	9	460	210	0.96	0.93	0.94	0.92	0.85
10	10	480	230	0.96	0.93	0.95	0.92	0.87
15	1	300	50	0.56	0.42	0.46	0.39	0.28
15	2	330	80	0.74	0.62	0.65	0.58	0.45
15	3	360	110	0.82	0.72	0.75	0.69	0.56
15	4	390	140	0.86	0.78	0.80	0.75	0.64
15	5	420	170	0.88	0.81	0.84	0.79	0.69
15	6	450	200	0.90	0.84	0.86	0.82	0.73
15	7	480	230	0.91	0.85	0.87	0.84	0.76
15	8	500	250	0.92	0.87	0.88	0.85	0.78
15	9	500	250	0.92	0.88	0.90	0.87	0.80
15	10	500	250	0.93	0.89	0.91	0.88	0.82
20	1	300	50	0.56	0.42	0.46	0.39	0.27
20	2	340	90	0.72	0.60	0.64	0.57	0.44
20	3	380	130	0.79	0.69	0.72	0.66	0.54
20	4	420	170	0.82	0.74	0.77	0.72	0.61
20	5	460	210	0.84	0.77	0.80	0.75	0.66
20	6	500	250	0.86	0.79	0.82	0.78	0.69
20	7	500	250	0.87	0.81	0.83	0.80	0.72
20	8	500	250	0.88	0.83	0.85	0.82	0.74
20	9	500	250	0.90	0.85	0.86	0.83	0.77
20	10	500	250	0.91	0.86	0.88	0.85	0.79
25	1	300	50	0.55	0.41	0.45	0.38	0.27
25	2	350	100	0.70	0.58	0.62	0.55	0.43
25	3	400	150	0.76	0.66	0.69	0.64	0.52
25	4	450	200	0.79	0.71	0.73	0.68	0.58
25	5	500	250	0.81	0.74	0.76	0.71	0.62
25	6	500	250	0.83	0.76	0.78	0.74	0.66
25	7	500	250	0.85	0.78	0.80	0.77	0.69
25	8	500	250	0.86	0.8	0.82	0.79	0.72
25	9	500	250	0.87	0.82	0.84	0.81	0.74
25	10	500	250	0.89	0.84	0.85	0.83	0.77
50	1	300	50	0.55	0.41	0.45	0.38	0.27
50	2	400	150	0.64	0.53	0.56	0.50	0.39
50	3	500	250	0.68	0.57	0.6	0.54	0.45
50	4	500	250	0.71	0.61	0.64	0.59	0.50

50	5	500	250	0.74	0.65	0.67	0.63	0.54
50	6	500	250	0.76	0.68	0.70	0.66	0.59
50	7	500	250	0.78	0.71	0.73	0.69	0.63
50	8	500	250	0.80	0.74	0.76	0.72	0.66
50	9	500	250	0.82	0.76	0.78	0.75	0.69
50	10	500	250	0.84	0.79	0.80	0.77	0.72
100	1	300	50	0.56	0.42	0.46	0.39	0.27
100	2	500	250	0.60	0.47	0.51	0.45	0.34
100	3	500	250	0.64	0.52	0.56	0.50	0.40
100	4	500	250	0.68	0.57	0.60	0.55	0.46
100	5	500	250	0.71	0.61	0.64	0.59	0.51
100	6	500	250	0.73	0.65	0.67	0.63	0.55
100	7	500	250	0.76	0.68	0.70	0.66	0.59
100	8	500	250	0.78	0.71	0.73	0.70	0.63
100	9	500	250	0.80	0.74	0.76	0.72	0.67
100	10	500	250	0.82	0.76	0.78	0.75	0.70

Firing Unit : 2

Speed (m/ min)	Rounds	Target Size		Damage at Range(Charge)				
		Length (m)	Width (m)	5 km (4)	10 km (6)	10 km (7)	10 km (8)	15 km (8)
0	1	300	50	0.79	0.65	0.70	0.62	0.47
0	2	300	50	0.95	0.88	0.91	0.85	0.72
0	3	300	50	0.99	0.96	0.97	0.94	0.85
0	4	300	50	1.00	0.99	0.99	0.98	0.92
0	5	300	50	1.00	0.99	1.00	0.99	0.96
0	6	300	50	1.00	1.00	1.00	1.00	0.98
0	7	300	50	1.00	1.00	1.00	1.00	0.99
0	8	300	50	1.00	1.00	1.00	1.00	0.99
0	9	300	50	1.00	1.00	1.00	1.00	1.00
0	10	300	50	1.00	1.00	1.00	1.00	1.00
5	1	300	50	0.78	0.65	0.69	0.61	0.47
5	2	310	60	0.94	0.87	0.9	0.84	0.71
5	3	320	70	0.98	0.95	0.96	0.93	0.84
5	4	330	80	0.99	0.98	0.98	0.97	0.91
5	5	340	90	1.00	0.99	0.99	0.98	0.94
5	6	350	100	1.00	0.99	1.00	0.99	0.97
5	7	360	110	1.00	1.00	1.00	0.99	0.98
5	8	370	120	1.00	1.00	1.00	1.00	0.99

5	9	380	130	1.00	1.00	1.00	1.00	0.99
5	10	390	140	1.00	1.00	1.00	1.00	0.99
10	1	300	50	0.79	0.66	0.70	0.62	0.47
10	2	320	70	0.93	0.86	0.89	0.83	0.71
10	3	340	90	0.97	0.93	0.95	0.91	0.83
10	4	360	110	0.98	0.96	0.97	0.95	0.89
10	5	380	130	0.99	0.98	0.98	0.97	0.93
10	6	400	150	0.99	0.98	0.99	0.98	0.95
10	7	420	170	0.99	0.99	0.99	0.98	0.96
10	8	440	190	1.00	0.99	0.99	0.99	0.97
10	9	460	210	1.00	0.99	0.99	0.99	0.98
10	10	480	230	1.00	0.99	1.00	0.99	0.98
15	1	300	50	0.79	0.66	0.70	0.62	0.47
15	2	330	80	0.92	0.85	0.87	0.82	0.69
15	3	360	110	0.95	0.91	0.93	0.90	0.81
15	4	390	140	0.97	0.94	0.95	0.93	0.87
15	5	420	170	0.98	0.96	0.97	0.95	0.90
15	6	450	200	0.98	0.97	0.97	0.96	0.92
15	7	480	230	0.98	0.97	0.98	0.97	0.94
15	8	500	250	0.99	0.98	0.98	0.97	0.95
15	9	500	250	0.99	0.98	0.98	0.98	0.96
15	10	500	250	0.99	0.98	0.99	0.98	0.96
20	1	300	50	0.79	0.65	0.69	0.61	0.47
20	2	340	90	0.90	0.83	0.86	0.80	0.68
20	3	380	130	0.94	0.89	0.91	0.88	0.78
20	4	420	170	0.95	0.92	0.93	0.91	0.84
20	5	460	210	0.96	0.94	0.95	0.93	0.87
20	6	500	250	0.97	0.95	0.96	0.94	0.89
20	7	500	250	0.97	0.96	0.96	0.95	0.91
20	8	500	250	0.98	0.96	0.97	0.96	0.93
20	9	500	250	0.98	0.97	0.97	0.96	0.94
20	10	500	250	0.98	0.97	0.98	0.97	0.95
25	1	300	50	0.79	0.66	0.7	0.62	0.47
25	2	350	100	0.89	0.82	0.84	0.79	0.68
25	3	400	150	0.92	0.88	0.89	0.86	0.77
25	4	450	200	0.94	0.90	0.92	0.89	0.82
25	5	500	250	0.95	0.92	0.93	0.91	0.85
25	6	500	250	0.96	0.93	0.94	0.92	0.88
25	7	500	250	0.96	0.94	0.95	0.94	0.90

25	8	500	250	0.97	0.95	0.96	0.95	0.91
25	9	500	250	0.97	0.96	0.96	0.95	0.93
25	10	500	250	0.98	0.97	0.97	0.96	0.94
50	1	300	50	0.79	0.65	0.69	0.61	0.47
50	2	400	150	0.85	0.76	0.79	0.74	0.63
50	3	500	250	0.87	0.80	0.82	0.78	0.69
50	4	500	250	0.89	0.83	0.85	0.81	0.74
50	5	500	250	0.91	0.86	0.87	0.84	0.78
50	6	500	250	0.92	0.88	0.89	0.87	0.82
50	7	500	250	0.93	0.90	0.91	0.89	0.85
50	8	500	250	0.94	0.92	0.92	0.91	0.87
50	9	500	250	0.95	0.93	0.94	0.92	0.89
50	10	500	250	0.96	0.94	0.95	0.94	0.91
100	1	300	50	0.79	0.66	0.70	0.62	0.47
100	2	500	250	0.82	0.71	0.75	0.68	0.56
100	3	500	250	0.84	0.76	0.78	0.73	0.63
100	4	500	250	0.87	0.80	0.82	0.77	0.69
100	5	500	250	0.89	0.83	0.85	0.81	0.75
100	6	500	250	0.90	0.86	0.87	0.84	0.79
100	7	500	250	0.92	0.88	0.89	0.87	0.82
100	8	500	250	0.93	0.90	0.91	0.89	0.85
100	9	500	250	0.93	0.91	0.92	0.91	0.88
100	10	500	250	0.93	0.93	0.93	0.92	0.90

LIST OF REFERENCES

American Defense Preparedness Association, *Proceedings, 4th International Cannon Artillery Firepower Symposium & Exhibition*, Arlington, VA, June 1995.

Department of Defense, *Department of Defense Instruction 5000.2 Defense Management Policies and Procedures*, Washington, D.C., February 1991.

Department of Defense, *Department of Defense Instruction 5000.2-M Defense Acquisition Management Documentation and Reports*, Washington, D.C., February 1991.

Fowles, G. R., *Analytical Mechanics, Fourth Edition*, Harcourt Brace Jovanovich College Publisher, Orlando FL, 1986.

Klingenberg, Günter and Heimerl, Joseph M., *Gun Muzzle Blast and Flash, Volume 139, Progress in Astronautics and Aeronautics*, American Institute of Astronautics and Aeronautics, Washington, D.C., December 1991.

Gould, H. and Tobochnik, J., *An Introduction to Computer Simulation Methods : Applications to Physical Systems Part 1*, Addison-Wesley Publishing Company, Menlo Park, CA, March 1988.

Headquarters, Department of the Army, *Field Manual 6-20 Fire Support in Airland battle*, Washington, D.C., December 1990.

Headquarters, Department of the Army, *Training Circular 6-40 Field Artillery Manual Cannon Gunnery*, Washington, D.C., December 1984.

Headquarters, Department of the Army, *Firing Table FT 155-AM-2 for Cannon, 155 mm howitzer*, Washington, D.C., March 1983.

Jane's Information Group, Surrey, *Jane's Armor and Artillery*, United Kingdom, December 1994.

Ministry of National Defense, Korea, *Defense White Paper*, Seoul, Korea, October 1994.

U.S. Army Logistics Management College, *Cost Estimating Reference Book*, Fort Lee, VA, October 1991.

The International Institute for Strategic Studies, *The Military Balance 1994-1995*, London, United Kingdom, 1994.

U.S. government Printing Office, *The U.S. Standard Atmosphere*, Washington, D.C., 1962.

Technical Management Department, Defense System Management College, *Systems Engineering Management Guide*, U.S. government Printing Office, Washington, D.C., January 1990.

Rice, John A., *Mathematical Statistics and Data Analysis*, Second Edition, Duxbury Press, Belmont, CA, 1994.

Sedgewick, Robert, *Algorithms in C*, Addison-Wesley Publishing Company, Menlo Park, CA, December 1990.

BIBLIOGRAPHY

Headquarters, Department of the Army, *Field Manual 6-20 Fire support in Airland battle*, Washington, D.C., December 1990.

Headquarters, Department of the Army, *Training Circular 6-40 Field artillery Manual Cannon Gunnery*, Washington, D.C., December 1984.

Department of Defense, *Department of Defense Instruction 5000.2 Defense Management Policies and Procedures*, Washington, D.C., February 1991.

Department of Defense, *Department of Defense Instruction 5000.2-M Defense Acquisition Management Documentation and Reports*, Washington, D.C., February 1991.

Habayeb, A. R., *Systems Effectiveness*, Yarmouk University, Pergamon Press, Elmsford, NY, 1987.

Dastrup, Boyd L., *King of Battle : A Branch History of the U.S. Army's Field Artillery*, U.S. Army Training and Doctrine Command, Fort Monroe, VA, 1992.

Blanchard, Benjamin S. , Fabrycky, Wolter J., *Systems Engineering and Analysis*, Prentice Hall, Englewood Cliffs, NJ, 1990.

Rice, John A., *Mathematical Statistics and Data Analysis*, Second Edition, Duxbury Press, Belmont, CA, 1994.

Sedgewick Robert , *Algorithms in C*, Addison-Wesley Publishing Company, Menlo Park, CA, December 1990.

U.S. Army Logistics Management College, *Cost Estimating Reference Book*, Fort Lee, VA, October 1991.

Esary, James D., *Studies on Damage Aggregation for Weapons Salvos*, Naval Postgraduate School, Monterey, CA, July 1990.

Esary, James D., *Studies on Damage Aggregation for Weapons Salvos II*, Naval Postgraduate School, Monterey, CA, December 1991.

Gould, Harvey and Tobochnik, Jan, *An Introduction to Computer Simulation Methods : Applications to Physical Systems Part I*, Addison-Wesley Publishing Company, Menlo Park, CA, March 1988.

Fowles, Grant R., *Analytical Mechanics, Fourth Edition*, Harcourt Brace Jovanovich College Publisher, Orlando FL, 1986.

Klingenbereg, Günter and Joseph Heimerl, M., *Gun Muzzle Blast and Flash, Volume 139, Progress in Astronautics and Aeronautics*, American Institute of Astronautics and Aeronautics, Washington, D.C., December 1991.

Perla, Peter P., *The Art of War Gaming*, U. S. Naval Institute, Annapolis, Maryland, 1990.

INITIAL DISTRIBUTION LIST

1. Defense Technical Information Center 2
8725 John J. Kingman Rd., STE 0944
Ft. Belvoir, VA 22060-6218
2. Library, Code 52 2
Naval Postgraduate School
Monterey, CA 93943-5002
3. Professor Robert E. Ball 2
Code AA/BP
Naval Postgraduate School
Monterey, CA 93943
4. Professor William B. Colson 2
Code PH/CW
Chairman, Department of Physics
Naval Postgraduate School
Monterey, CA 93943
5. Major Kang, Chunsoo 2
111-5, Myunmok-dong
Jungrang-gu, Seoul, 131-206
Republic of Korea
6. Woodang Library 2
Korea Military Academy
P.O. Box 77, Gongneung-dong
Nowon-gu, Seoul, 139-799
Republic of Korea
7. LTC. Park, Bongsuk 1
Education Office, Deputy Chief of Staff-Personnel
P.O. Box 4, Bunam-Ri
Duma-myun, Nonsan-gun, Choongnam, 320-919
Republic of Korea
8. COL. Insoo Chung 1
Defense Research & Development Attache
Embassy of the Republic of Korea
2400 Wilson Blvd.
Arlington, VA 22201

- | | | |
|-----|--|---|
| 9. | COL. Park, Soonheon
P.O. Box 30, Sanjung-ri
Yungbook-myun, Pochun-gun, 487-890
Republic of Korea | 2 |
| 10. | LTC. Jung, K. Y.
Office of Chief of Staff of the R.O.K Army
P.O. Box 1, Bunam-Ri
Duma-myun, Nonsan-gun, Choongnam, 320-919
Republic of Korea | 1 |
| 11. | COL. Choi, H.B.
508-704 Ssangyong APT.
717 Madoo-dong, Goyang-city
Gyunggi-do, 411-350
Republic of Korea | 2 |
| 12. | Major Kim, Dohyun
1376 Midland Avenue (APT. 608)
Bronxville, NY 10708 | 1 |