

NASA TECHNICAL NOTE

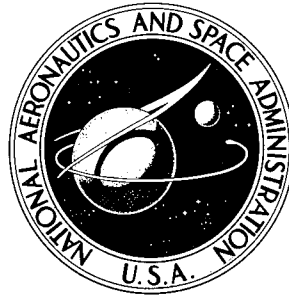

NASA TN D-5073

NASA TN D-5073

19960411 014

FRICION AND WEAR
OF NINE SELECTED POLYMERS
WITH VARIOUS FILLERS
IN LIQUID HYDROGEN

DEPARTMENT OF DEFENSE
PLASTICS TECHNICAL EVALUATION CENTER
PICATINNY ARSENAL, DOVER, N. J.

by *Donald W. Wisander and Robert L. Johnson*

*Lewis Research Center
Cleveland, Ohio*

DISTRIBUTION STATEMENT A
Approved for public release;
Distribution Unlimited

PLASTEC 12027

NATIONAL AERONAUTICS AND SPACE ADMINISTRATION • WASHINGTON, D. C. • MARCH 1969

THIS DOCUMENT IS UNCLASSIFIED

DISCLAIMER NOTICE

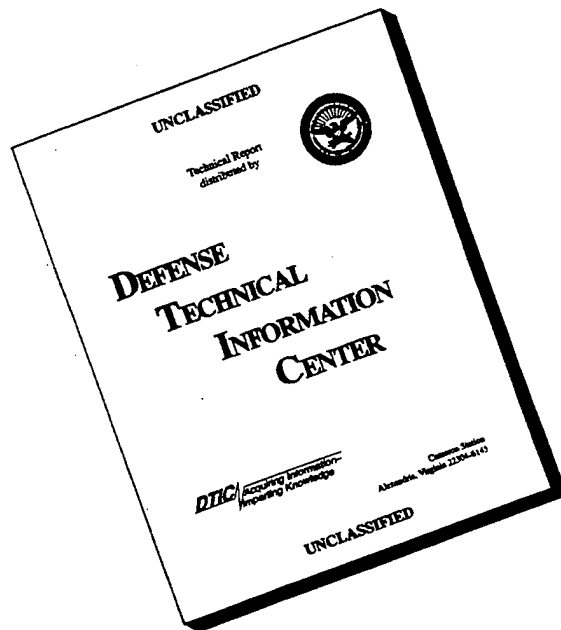

THIS DOCUMENT IS BEST QUALITY AVAILABLE. THE COPY FURNISHED TO DTIC CONTAINED A SIGNIFICANT NUMBER OF PAGES WHICH DO NOT REPRODUCE LEGIBLY.

NASA TN D-5073

FRICITION AND WEAR OF NINE SELECTED POLYMERS WITH
VARIOUS FILLERS IN LIQUID HYDROGEN

By Donald W. Wisander and Robert L. Johnson

Lewis Research Center
Cleveland, Ohio

NATIONAL AERONAUTICS AND SPACE ADMINISTRATION

For sale by the Clearinghouse for Federal Scientific and Technical Information
Springfield, Virginia 22151 - CFSTI price \$3.00

ABSTRACT

Experiments were conducted with a 0.1875-inch- (0.476-cm-) radius hemisphere of nine polymers in sliding contact with a rotating 17-4 PH disk in liquid hydrogen. Sliding velocity was 2300 feet per minute (701 m/min) at a load of 1 kilogram. Results indicate that several filled polymers show promise. Graphite-filled polyamide (nylon), graphite filled and glass-fiber-filled polytrifluorochlorethylene (PTFCE), and a 50-percent polytetrafluoroethylene (PTFE) - 50-percent polyparaphenyl have friction and wear similar to filled-PTFE composites commonly used in cryogenic applications.

FRICITION AND WEAR OF NINE SELECTED POLYMERS WITH VARIOUS FILLERS IN LIQUID HYDROGEN

by Donald W. Wisander and Robert L. Johnson

Lewis Research Center

SUMMARY

Wear and friction of various polymers were measured in liquid hydrogen. The polymers used were acetal polyoxymethylene, acetal copolymer, polycarbonate, polyamide (nylon), polytrifluorochloroethylene (PTFCE), polyimide, polytetrafluoroethylene (PTFE), fluorinated ethylene propylene (FEP), and parapolyphenyl (PPP). PTFE was used as a filler in acetal polyoxymethylene, acetal copolymer, and polyparaphenyl; graphite or molybdenum disulfide (MoS_2) were fillers in nylon; and aluminum oxide (Al_2O_3), calcium difluoride (CaF_2), graphite, or glass fiber were fillers in PTFCE. These results were compared with a filled PTFE (80 PTFE + 15 glass fiber + 5 graphite, percent by weight).

Experiments were conducted using a 0.1875-inch- (0.476-cm-) radius hemispherically tipped rider sliding on the flat surface of a rotating disk (17-4 PH). The sliding velocity was 2300 feet per minute (701 m/min) at a load of 1 kilogram. All experiments were conducted with specimens submerged in liquid hydrogen.

Results obtained at the preceding test conditions indicated that several unfilled polymers have about the same or lower wear rates than unfilled PTFE. Friction of most of the polymers was similar to that of PTFE (with the exception of polyimide which had a friction coefficient more than twice that of PTFE). Results indicated that the addition of 15- to 25-percent graphite or glass-fiber filler to PTFCE gave wear rates similar to that of the filled PTFE. Although the friction coefficient of the filled PTFCE materials was 50 percent higher than filled PTFE, the higher compressive modulus of PTFCE may outweigh the sacrifice in frictional heating.

Although the materials investigated did not have better friction and wear than PTFE, their higher compressive modulus warrant their use in applications where PTFE is now employed. The lowest wear was obtained with a 50-percent PTFE and 50-percent polyparaphenyl composite. However, with both friction and wear considered, the best results were obtained with compositions containing 40-percent polyamide and 60-percent graphite; 15 percent Al_2O_3 and 85 percent PTFCE; 15 and 25 percent glass fiber (balance PTFCE). All compositions are given in weight percent.

INTRODUCTION

The poor lubricating properties of liquid hydrogen require that surfaces in sliding contact in the presence of liquid hydrogen be self-lubricating. The bearings and seals of liquid-hydrogen turbopumps require materials that will operate for long periods of time under severe conditions of load and speed. PTFE (polytetrafluoroethylene), as a base material, has been used with success for bearing and seal materials in liquid hydrogen (refs. 1 to 3). These materials, however, tend to cold flow under pressure and to exhibit a large coefficient of thermal contraction. For these reasons, new materials (possibly incorporating PTFE) are needed to minimize these undesirable characteristics.

Two methods that have already improved the wear and strength characteristics of bearing and seal materials are (1) the use of PTFE as a filler in a phenol formaldehyde base composite (ref. 2) and (2) the use of PTFE as a binder in fabric-base polymer laminates (ref. 4).

Another method, presently proposed for improving the strength of bearing and seal materials, is to use another polymer for the base material. Such polymers as acetal polyoxymethylene, acetal copolymer, polycarbonate, polyimide, polyamide (nylon 6/6), fluorinated ethylene propylene (FEP), polytetrafluoroethylene (PTFE), polytrifluoroethylene (PTFCE), and polyparaphenyl (PPP) merit some study for possible application as seal materials. Most of these polymers have been investigated at room temperature (refs. 5 to 12), but little liquid-hydrogen information is available. In this study, PTFE was used as a filler in acetal polyoxymethylene and acetal copolymer. Polyamide and PTFCE were tested with various inorganic fillers.

The objectives of this investigation were to determine (1) whether these polymer materials have good lubricating properties, (2) whether these polymer materials have mechanical properties better than PTFE for sliding surface contact in liquid hydrogen, and (3) the effect of fillers on these properties. Hemispherically tipped riders were run in sliding contact with a rotating disk. The disk material was 17-4 PH stainless steel. Data were obtained with a sliding velocity of 2300 feet per minute (701 m/min) at a load of 1 kilogram.

APPARATUS AND PROCEDURE

The apparatus used in this investigation is shown schematically in figure 1. The basic elements consist of a hemispherically tipped 0.1875-inch- (0.476-cm-) radius rider specimen held in sliding contact with the lower flat surface of a rotating disk 2.50 inches (6.35 cm) in diameter. The experiments were conducted with specimens completely submerged in liquid hydrogen.

The rider specimen was supported by a pivoted arm and bellows assembly. Friction-

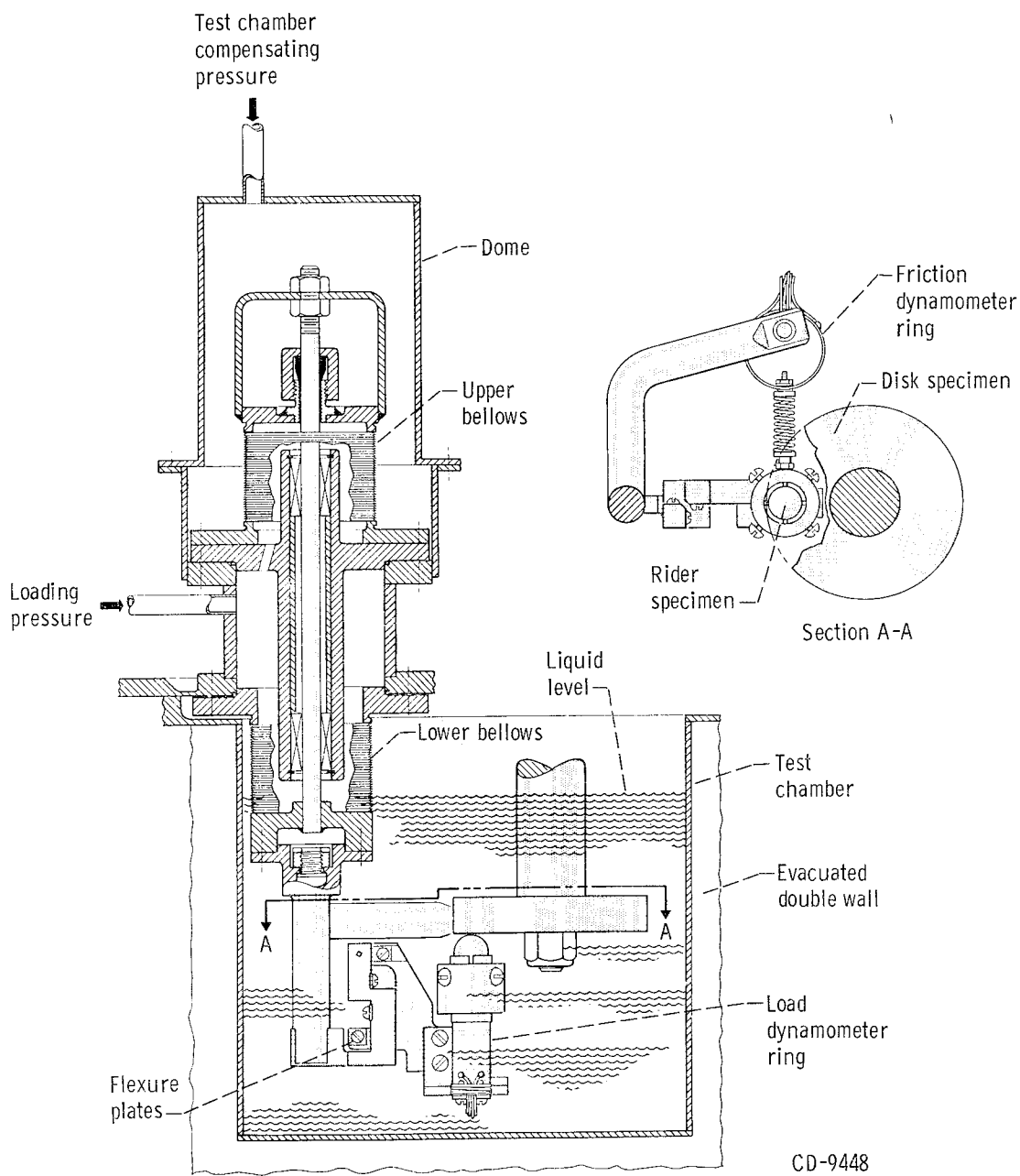

Figure 1. - Cryogenic fuel friction apparatus with specimen loading system.

tional force was measured by a load ring dynamometer (mounted in the test chamber) which restrained the pivoted arm motion when sliding contact was induced. Load force was measured by a second load ring dynamometer mounted directly under the test specimen. A recording potentiometer was used as a strain indicator. (Dynamometers were calibrated in liquid hydrogen by applying weights and then compensated for buoyancy effects of the weights).

The rider specimen was loaded (1 kg) against the rotating disk specimen (17-4 pH, Rockwell C-40) by a helium-pressurized bellows assembly. Differential areas of the two bellows produced the required load. Pressure in the dome compensated for the pressure in the test chamber. The sliding velocity used for these experiments was 2300 feet per minute (701 m/min) (measured with a magnetic transducer and electronic counter).

Metal disk specimens were prepared by the following procedure:

- (1) Finish ground to 4 microinches (1.02×10^{-5} cm) rms
- (2) Scrubbed with moist levigated alumina
- (3) Washed in tap water
- (4) Washed in distilled water
- (5) Stored in a desiccator

Polymer rider specimens were cleaned as follows:

- (1) Washed and cleaned with 100-percent ethyl alcohol (U. S. P. absolute alcohol)
- (2) Stored in a desiccator

The test chamber was cleaned with 100-percent ethyl alcohol prior to each run. After the test specimens were installed, the test chamber was closed, purged 15 minutes with helium gas, and filled with liquid hydrogen through a closed loop. Run duration was 10 to 60 minutes, depending on wear rate. The wear of the rider specimen was determined by measuring the wear scar diameter and calculating wear volume.

The purpose of determining the values of contraction coefficients presented in table I was to have data by which the various materials of the program could be compared on the same basis. Many of these materials have published expansion coefficients (instead of percentage change) but they are determined by various methods selected by the respective suppliers and over different temperature ranges. Also, the properties vary with the batch and the manufacturing methods. The lack of a consistent method for measurement explains the wide variation of values from the commercial suppliers. The values determined in this investigation are intended as comparative rather than precise values. The value obtained for PTFE (a material for which the expansion or coefficient of expansion is widely reported) is close to that reported in reference 5. The difference noted (1.5 against 2.1 percent) is likely a result of the direction of measurement and of the crystallinity of the specimen. Separate tests of specimens of three different crystallinities showed that contraction along the molding axis decreases with increased crystallinity but increases across the diameter (perpendicular to axis), the "average" being

TABLE I. - MEASURED MECHANICAL PROPERTIES

FOR MATERIALS TESTED

(a) SI Units^a

Material	Percent contraction, 293 to 77 K	Compressive ^b modulus (293 K), N/cm ²	Shear ^c strength (77 K), N/cm ²
Acetal polyoxymethylene	1.1	345 000	13 800
Acetal polyoxymethylene + 22% PTFE fiber	1.1	324 000	14 500
Polycarbonate	.8	241 000	12 400
Polyimide	.8	269 000	13 800
Fluorinated ethylene propylene (FEP)	.93	55 000	13 800
Acetal copolymer	1.2	283 000	20 700
Acetal copolymer + 20% PTFE powder	1.1	262 000	17 900
Nylon 6/6 (polyamide)	1.1	193 000	12 400
Nylon + 10% MoS ₂	.78	145 000	5 900
Nylon + 20% graphite	.65	158 000	6 200
Nylon + 60% graphite	.39	310 000	3 500
Polytrifluorochloroethylene (PTFCE)	.53	165 000	16 500
PTFCE + 15% Al ₂ O ₃	.75	255 000	12 400
PTFCE + 25% Al ₂ O ₃	.53	379 000	6 900
PTFCE + 15% CaF ₂	.67	303 000	7 600
PTFCE + 25% CaF ₂	.53	248 000	8 300
PTFCE + 15% graphite	1.1	324 000	8 300
PTFCE + 25% graphite	.4	434 000	8 300
PTFCE + 15% glass fiber	1.1	496 000	-----
PTFCE + 25% glass fiber	----	496 000	13 800
PTFCE + 25% PTFCE liquid	0.67	21 000	6 900
Polyparaphenyl	.67	Fractured	Crumbled
Polyparaphenyl + 50% PTFE	.67	Fractured	2 400
Polytetrafluoroethylene (PTFE)	1.5	55 000	5 500
PTFE + 5% graphite + 15% glass fiber	1.6	76 000	6 100
Mechanical carbon	.07	1 400 000	-----

^aConverted from U. S. Customary Units.^bRounded to nearest 1000 N/cm².^cRounded to nearest 100 N/cm².

TABLE I. - Concluded. MEASURED MECHANICAL PROPERTIES
FOR MATERIALS TESTED

(b) U. S. Customary Units

Material	Percent contraction 68 ^o to -320 ^o F	Compressive modulus (68 ^o F), psi	Shear strength (-320 ^o F), psi
Acetal polyoxymethylene	1.1	500 000	20 000
Acetal polyoxymethylene + 22% PTFE fiber	1.1	470 000	21 000
Polycarbonate	.8	350 000	18 000
Polyimide	.8	390 000	20 000
Fluorinated ethylene propylene (FEP)	.93	80 000	20 000
Acetal copolymer	1.2	410 000	30 000
Acetal copolymer + 20 % PTFE powder	1.1	380 000	26 000
Nylon 6/6 (polyamide)	1.1	280 000	18 000
Nylon + 10% MoS ₂	.78	210 000	8 600
Nylon + 20% graphite	.65	230 000	9 000
Nylon + 60% graphite	.39	450 000	5 100
Polytrifluorochloroethylene (PTFCE)	.53	240 000	24 000
PTFCE + 15% Al ₂ O ₃	.75	370 000	18 000
PTFCE + 25% Al ₂ O ₃	.53	550 000	10 000
PTFCE + 15% CaF ₂	.67	440 000	11 000
PTFCE + 25% CaF ₂	.53	360 000	12 000
PTFCE + 15% graphite	1.1	470 000	12 000
PTFCE + 25% graphite	.4	630 000	12 000
PTFCE + 15% glass fiber	1.1	720 000	-----
PTFCE + 25% glass fiber	----	720 000	20 000
PTFCE + 25% PTFCE liquid	0.67	30 000	10 000
Polyparaphenyl	.67	Fractured	Crumbled
Polyparaphenyl + 50% PTFE	.67	Fractured	3 500
Polytetrafluoroethylene (PTFE)	1.5	80 000	8 000
PTFE + 5% graphite + 15% glass fiber	1.6	110 000	8 900
Mechanical carbon (typical)	.07	2 000 000	-----

close to 2 percent for all three specimens.

Contraction measurements were made with a ten-thousandth micrometer. Specimens (1 in. (2.54 cm) long by 3/8 in. (0.95 cm) diam) were measured at room temperature and then submerged in liquid nitrogen by using long tongs. When boiling subsides, the specimen is placed in the jaws of the micrometer and measured quickly before the specimen expands into the jaws. The specimen is recooled and quickly remeasured. This procedure is repeated six to eight times until no noticeable further contraction is noted. The shrinkage is then divided by the room-temperature length and multiplied by 100 to obtain percent.

The apparatus and procedure for obtaining the compressive modulus and the shear strength data shown in table I are completely described in reference 2. Basically the apparatus consists of a precision tensile testing machine utilizing two test jigs that perform the functions of a compression test and of a shear test in the required environment. A vacuum flask, with integral anvil in the bottom, supports the test jig load when in compression. The vacuum flask can be used at room temperature or with liquid nitrogen.

Compression specimens were 0.750 ± 0.001 inch long by 0.250 ± 0.001 inch in diameter (19.05 ± 0.025 by 6.35 ± 0.025 mm); shear specimens were 1 inch long by 0.125 ± 0.001 inch in diameter (25.4 by 3.175 ± 0.025 mm). Compressive load was 200 pounds (91 kg) maximum applied at 0.05 inch per minute (1.27 mm/min); shear rate was 0.5 inch per minute (12.7 mm/min).

RESULTS AND DISCUSSION

Mechanical Properties

Table I presents measured mechanical properties data for the materials of this investigation. Identical data in different units are presented in table I(a) (SI units) and table I(b) (U.S. Customary units). These data can be generalized with regard to the influence of fillers on mechanical properties of the various solid polymers.

In general, the shear strengths of the compositions are reduced by the addition of fillers, a desirable result when low friction is the objective. Friction force depends primarily on the shear strength of the surface layers of the polymer and secondarily on the real area in contact which is responsive to the hardness or yield strength in compression of the material.

The compressive modulus, as obtained in the determinations reported, is considered more meaningful than the ultimate compressive yield strength from the lubrication standpoint. This is a particularly significant consideration when junction growth during sliding must be anticipated. Solid polymers (plastics) are particularly susceptible to junction growth during the sliding process (ref. 13). The data of table I show that the compressive modulus was significantly affected by fillers.

Fluorocarbon polymers (PTFE, FEP, and PTFCE) are well known to be subject to cold flow under sustained loading. Such behavior limits the usefulness of those polymers in many seal and bearing applications. Fillers are commonly used to reduce the cold-flow problem in engineering applications. The data of table I show the magnitude of improvement in compressive modulus for the fluorocarbon polymers with the addition of fillers. Compressive modulus and cold flow are related phenomena, and reduced cold flow can be expected for materials of higher compressive modulus.

Earlier experience with solid polymers in cryogenic lubrication (ref. 14) showed that thermal contraction and expansion could be controlled by use of fillers. The experience of reference 14 was with thin films for which thermal contraction was critical to film adherence on a metal substrate. In the present experiments, thermal expansion was not usually significantly influenced by the addition of up to 25 weight percent of fillers. The exceptions to that generalization was the increase in expansion of 15-percent graphite or 15-percent glass fiber in PTFCE. In general, low concentrations of fillers should not disrupt the skeleton or matrix of the polymer and, therefore, would not be expected to have major influence on thermal expansion of unrestrained bodies.

Friction and Wear

Polymers without fillers. - Figure 2(a) presents friction and rider wear data for the series of polymers without fillers during sliding on 17-4 PH stainless steel in liquid hydrogen. Two sets of reference data are considered. First, data are presented for a mechanical carbon impregnated with a metal fluoride. This material is used for seals in hydrogen turbopumps. Second, data for polytetrafluoroethylene (PTFE) with and without a filler are considered because of the extensive experience with that material for many cryogenic and other friction surfaces. Only parapolyphenyl and polyimide had significantly greater friction than the mechanical carbon. Also, only polycarbonate, polyamide, and polytrifluorochloroethylene (PTFCE) gave higher wear than the unfilled PTFE.

The second reference material, PTFE, gave somewhat lower wear than the mechanical carbon. Compared with the reference materials, several of the polymers have sufficiently good friction and wear properties so that further study (such as with fillers) was merited.

Fluorinated ethylene propylene (FEP), acetal polyoxymethylene, and acetal copolymer had friction and wear similar to PTFE. These materials have better dimensional stability and lower thermal contraction than PTFE and might be considered for cryogenic applications now using PTFE. Although the wear of polycarbonate, PTFCE, and polyamide (nylon 6/6) is high, the friction coefficient and thermal contraction dictate

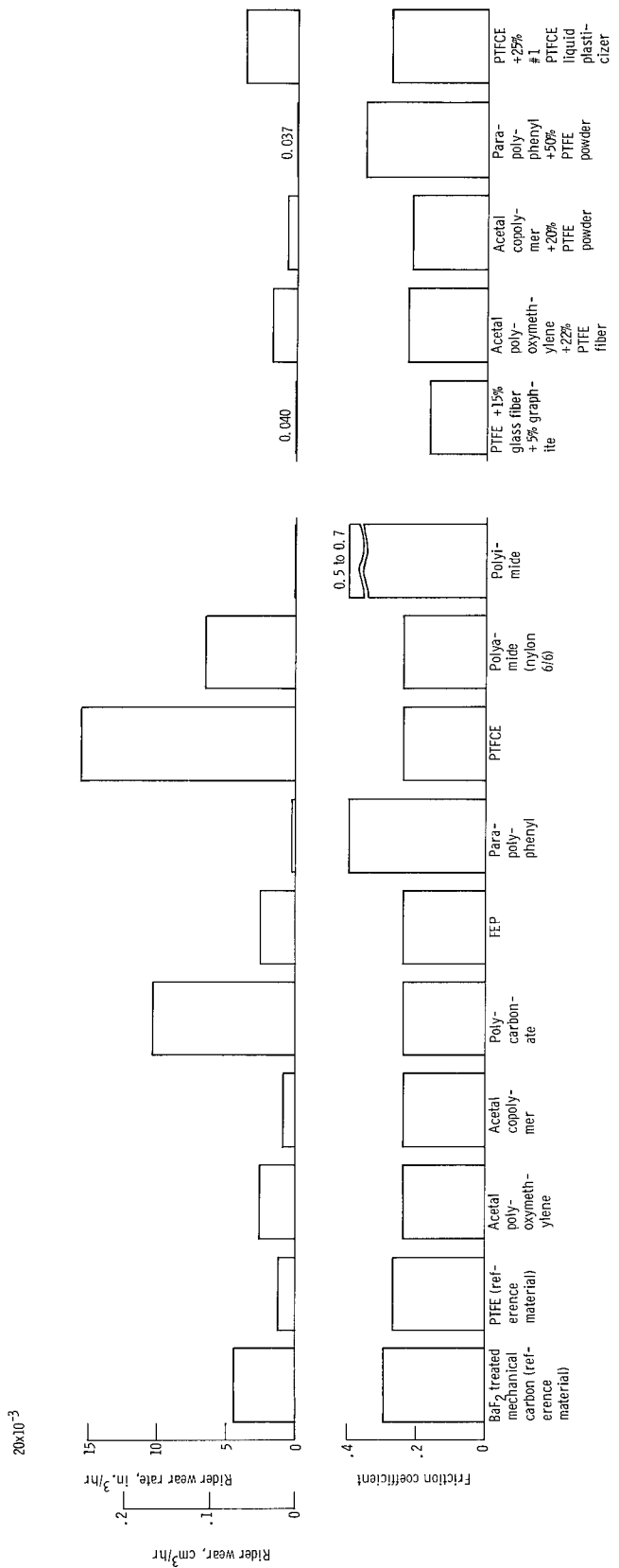
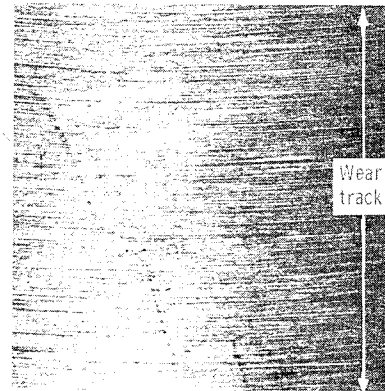

Figure 2. - Wear and friction of various polymers sliding against 17-4 PH stainless-steel disks in liquid hydrogen. Sliding velocity, 2300 feet per minute (701 m/min); load, 1 kilogram; run duration, 10 to 60 minutes; disk hardness, Rockwell C40.



Nylon rider



17-4 PH disk

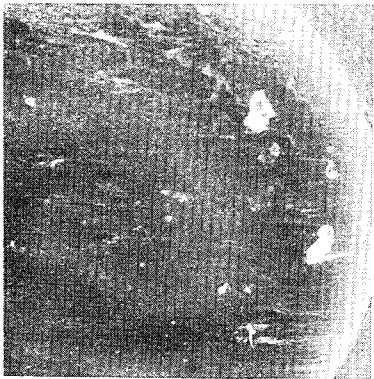

Polycarbonate rider

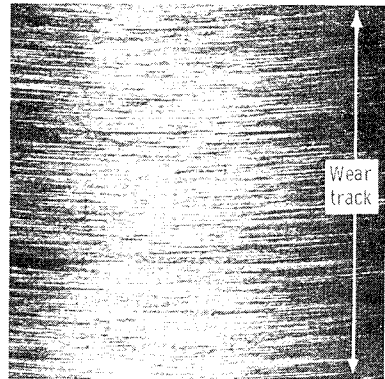

17-4 PH disk



Parapolyphenyl rider

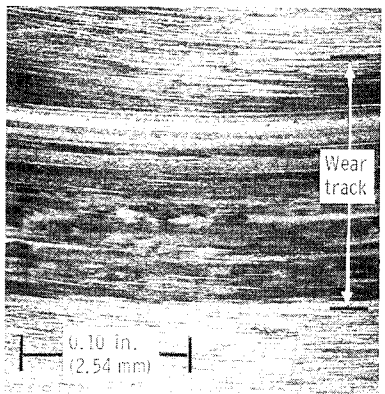

17-4 PH disk

C-68-3801

Figure 3. - Rider wear scars of polymers without fillers and respective disk wear tracks after running in liquid hydrogen. Sliding velocity, 2300 feet per minute (701 m/min); load, 1 kilogram; run duration, 10 to 60 minutes.

that fillers may improve their usefulness. (Nylon and PTFCE with fillers are discussed later in this report.) Figure 3 (top and center) shows typical wear surfaces for nylon and polycarbonate.

Polymers with MoS_2 , graphite, and PTFE fillers (inherently self-lubricating). -

Since PTFE is considered to be a good cryogenic lubricant, it was expected that another polymer containing PTFE as an additive might be an improvement over the unfilled polymer. PTFE was therefore used in acetal polyoxymethylene and acetal copolymer. Acetal polyoxymethylene with 22-percent PTFE fiber and acetal copolymer with 20-percent PTFE powder did not show a significant improvement in wear or friction coefficient over the unfilled polymer (fig. 2). Although PTFE fiber has 30 times the tensile strength of extruded PTFE, it did not show an advantage over the powdered PTFE as a filler for the acetal polyoxymethylene. This can be partly explained by the problems associated with distributing a fiber in a matrix. These problems are (1) proper orientation of the fiber relative to the sliding surface, and (2) effective chemical coupling agent to obtain good adherence of matrix to fiber. PTFE powder as a filler for parapolyphenyl (50-50 composition) reduced the brittleness at room temperature and reduced the wear rate in liquid hydrogen. (This wear rate is close to that obtained with the referenced filled PTFE, which is a material similar to that used for liquid-hydrogen bearing cages.) Wear surfaces for the parapolyphenyl are shown at the bottom of figure 3 and for the 50-50 composite are shown at the top of figure 4.

PTFCE with 25-percent PTFCE liquid plasticizer (No. 1 oil), reduced the wear of the polymer by a factor of 4 (fig. 2). Although this wear is still high, the effect of plasticizing on reducing wear is worthy of note.

Wear debris from the tests with nylon, polycarbonate, PTFCE, and the acetal polymers was ribbon-like. This is indicative of the effect of plasticity on the wear mechanism. The wear mechanism for these materials, as evidenced by the photographs of the rider specimens in figures 3, 4, and 7, show a skiving action between disk and rider. These ribbons are generally attached to the trailing edge of the rider wear surface, but occasionally a ribbon is found on the rider wear surface. The ribbon is V-shaped with the point toward the trailing edge. Polyimide and parapolyphenyl have a powdered wear debris. PTFE and FEP have wear debris composed of both ribbon and powder; the ribbons were not found attached to the rider.

The data of figure 5 show the effect of fillers on friction coefficient and wear of nylon. Very little effect on wear can be seen except for the 60-percent graphite-filled material. Although the wear of nylon is reduced by a factor of about 20 (with 60-percent graphite), it is still 7 times as high as the filled PTFE reference material. Examination of table I shows only a slight change in compressive modulus (room temperature) of nylon (6/6) with addition of filler except for the 60-percent graphite-filled material, which

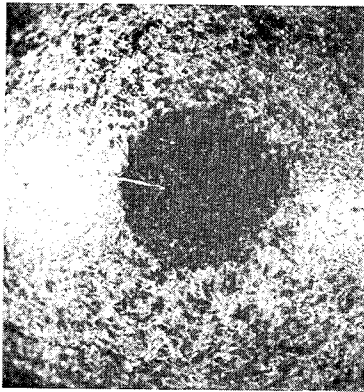

50-Percent parapolyphenyl plus
50-percent-PTFE rider

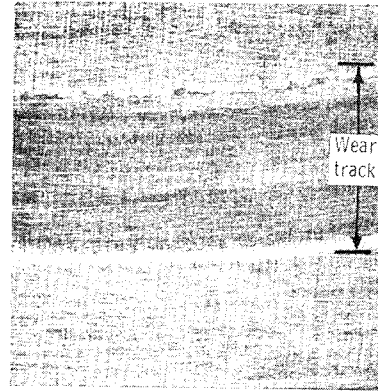

17-4 PH disk

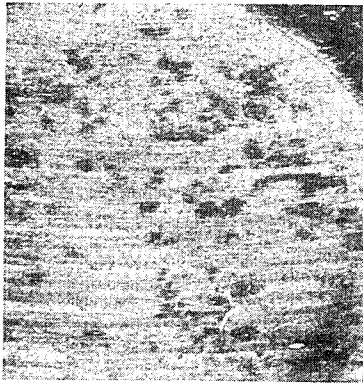

80-Percent-nylon plus 20-percent-
graphite rider

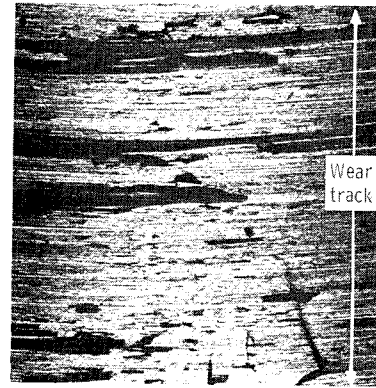

17-4 PH disk

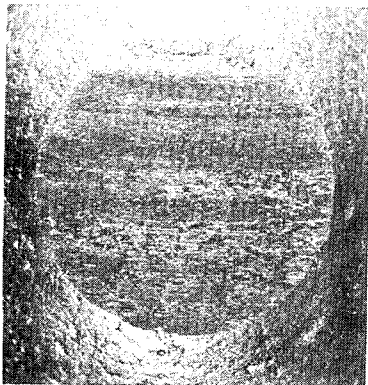

40-Percent-nylon plus 60-percent-
graphite rider

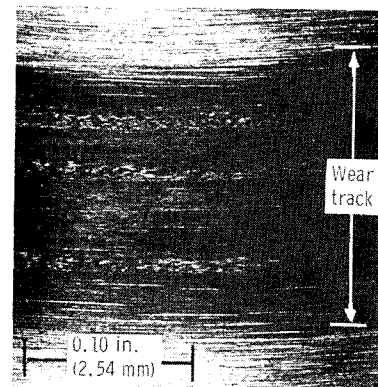

17-4 PH disk

C-68-3802

Figure 4. - Rider wear scars of three filled polymers and respective disk wear tracks after running in liquid hydrogen. Sliding velocity, 2300 feet per minute (701 m/min); load, 1 kilogram; run duration, 10 to 60 minutes.

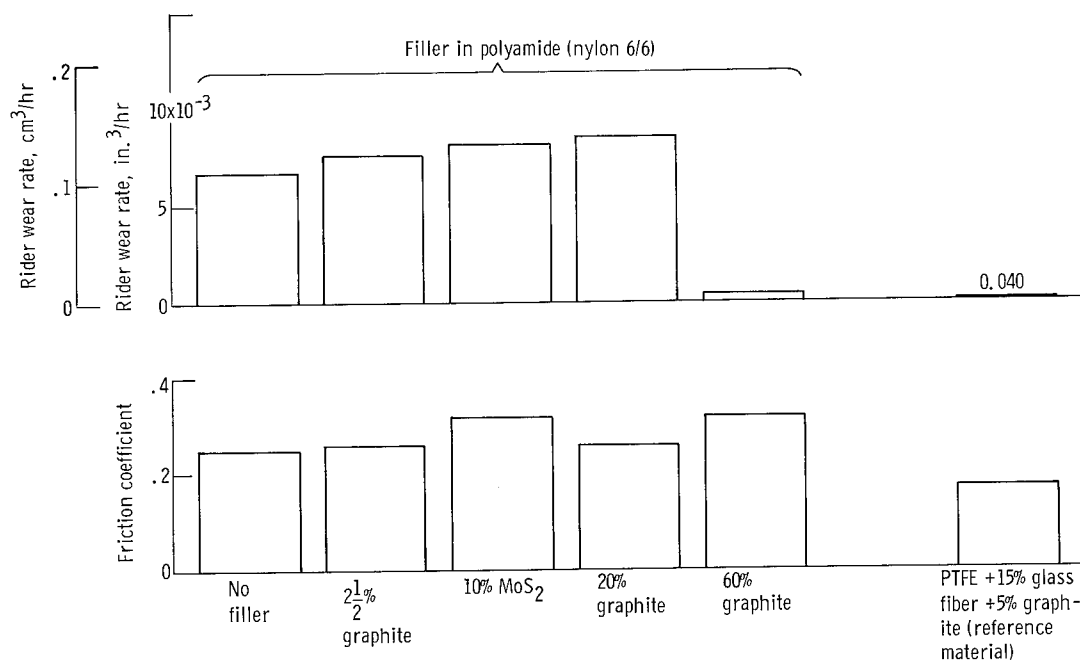

Figure 5. - Wear and friction of filled polyamide (nylon 6/6) sliding against 17-4 PH stainless-steel disks in liquid hydrogen. Sliding velocity, 2300 feet per minute (701 m/min); load, 1 kilogram; run duration, 20 to 30 minutes; disk hardness, Rockwell C40.

shows an increase of a factor of 2. Also, it can be seen that shear strength (liquid-nitrogen temperature) decreases with increasing percentage of filler; shear strength of the 60-percent graphite is less than one-third that of the unfilled nylon. The friction coefficient is not significantly influenced by the fillers (fig. 5). Wear debris with the filled nylons (except the 2½ percent graphite) was powdery. Transfer of the solid-lubricant fillers (MoS₂ or graphite) to the mating surface was evident only with 60-percent-graphite composition. Wear surfaces of two filled nylons are shown in figure 4.

As can be seen from figure 5, nylon with 60-percent filler (graphite) had significantly lower wear than the unfilled nylon. Such high concentrations of filler reduce the shear strength while at the same time increasing the compressive modulus (table I). While tensile tests were not conducted in this program, it is often reported that fillers reduce the tensile strength of polymers (refs. 5 and 15). The 60-percent graphite-filled nylon, while having satisfactory friction and wear properties, may not be sufficiently strong to replace PTFE in many applications. This reduction in strength of the nylon, brought about by adding a high concentration of a lubricating type filler, restricts its use to compressive applications such as dynamic mechanical seals.

PTFCE with fillers of graphite, Al₂O₃, CaF₂, or glass fibers. - In an attempt to reduce the wear rate without seriously impairing the shear strength, various fillers were added to PTFCE but the filler concentration was limited to 25 weight percent. The

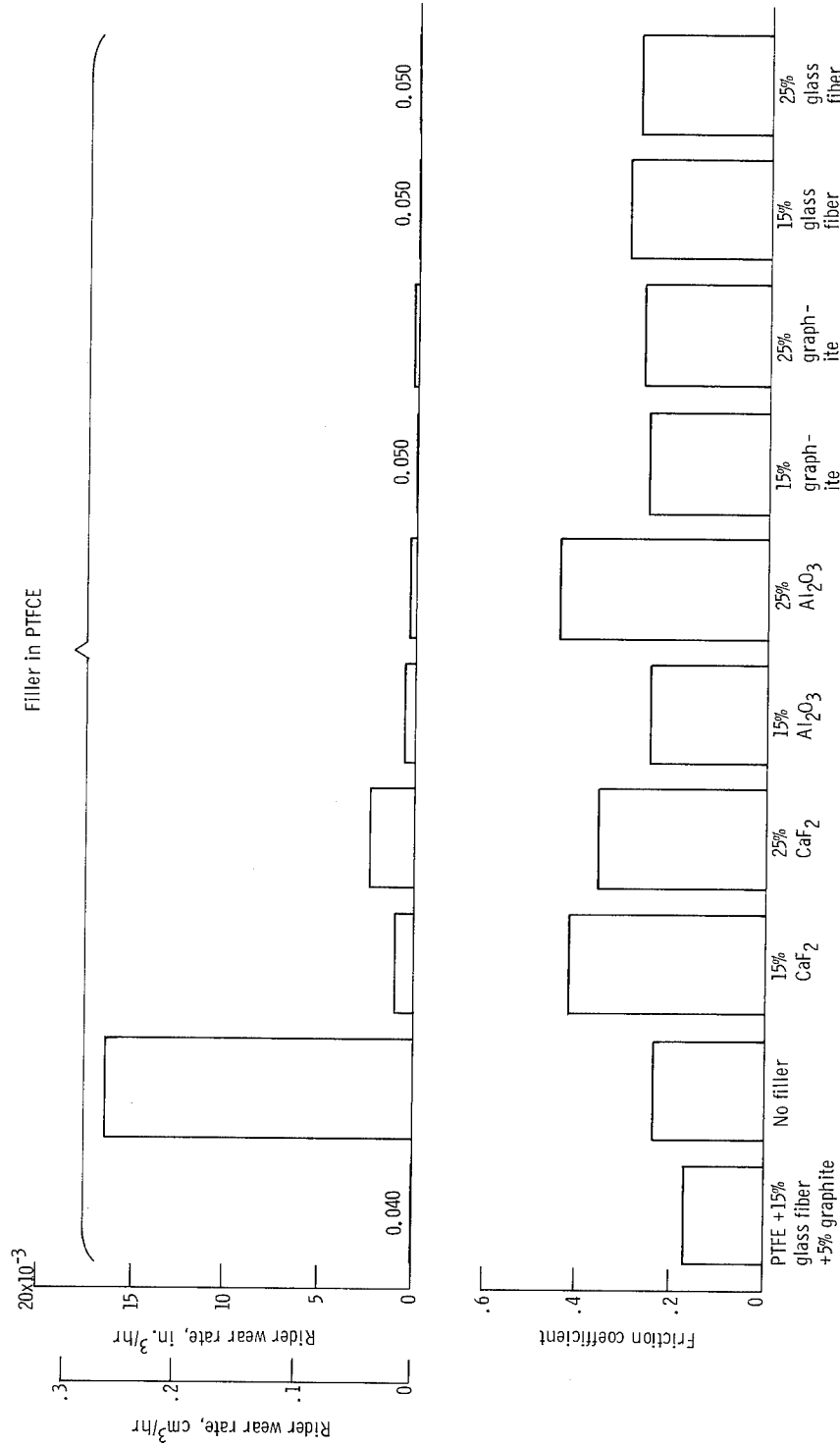
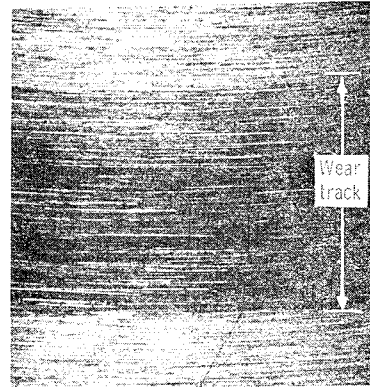

Figure 6. - Wear and friction of filled PTFCE sliding against 17-4 PH stainless-steel disks in liquid hydrogen. Sliding velocity, 2300 feet per minute (701 m/min); load, 1 kilogram; run duration, 10 to 60 minutes; disk hardness, Rockwell C40.



85-Percent-PTFCE plus 15-percent-graphite rider



17-4 PH disk



75-Percent-PTFCE plus 25-percent-glass-fiber rider

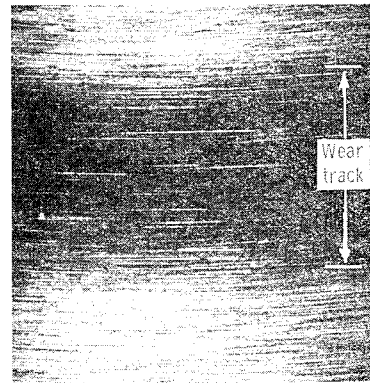

17-4 PH disk



85-Percent-PTFCE plus 15-percent-glass-fiber rider

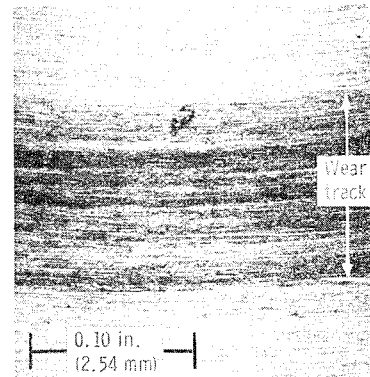

17-4 PH disk

C-68-3803

Figure 7. - Rider wear scars of three filled PTFCE specimens and respective disk wear tracks after running in liquid hydrogen. Sliding velocity, 2300 feet per minute (701 m/min); load, 1 kilogram; run duration, 10 to 60 minutes.

fillers chosen were selected for their possible application to liquid-oxygen systems (or possibly to liquid-fluorine systems). As shown in figure 6, wear rates of some of the filled PTFCE's (15 and 25 percent graphite, 15 and 25 percent glass fiber) are similar to the filled PTFE reference material. From table I, it can be seen that these four filled PTFCE composites have higher shear strength than the reference filled PTFE. The wear values for PTFE and the filled PTFE (fig. 2) show a wear rate reduction by a factor of about 30, but a comparison of the unfilled PTFCE and three of the filled PTFCE's (fig. 6) shows a wear rate reduction by a factor of about 300. This wear rate reduction is quite remarkable. It is important to note that this wear reduction was brought about by 15- to 25-weight-percent filler instead of the 60 weight percent in the case of nylon.

A comparison of the physical properties (table I) of the four selected filled PTFCE's with the filled PTFE reference material shows that the PTFCE's have higher compressive modulus (factors of 4 to 7). Thermal contraction of the filled PTFCE's are from one-fourth to two-thirds of the filled PTFE reference material.

Three of the remaining filled PTFCE's (15 and 25 percent CaF_2 and 25 percent Al_2O_3) had friction coefficients of about 0.4, with the 25-percent Al_2O_3 intermittently reaching values greater than 1. The wear tracks showed a brightly polished surface.

Wear tracks with glass-fiber-filled PTFCE showed light polishing, while the graphite fillers formed a black transfer film on the mating surface. Representative wear surfaces are shown in figure 7. Wear debris for all filled PTFCE's was powdered and did not adhere to the disk surface.

As can be seen from the foregoing discussion, fillers can reduce wear rate and improve mechanical properties (compressive modulus and shear strength). Also, some filler materials significantly increase the friction coefficient (three out of eight materials). Friction coefficient reflects the nature of the filler (e. g., abrasive or lubricant) as well as the extent of coupling of filler to the matrix. Poor coupling usually results in lower friction but with higher wear rate than for those with good coupling. Good coupling results in lower wear, the shear strength approaching that of the unfilled polymer (note PTFE and filled PTFE), and improved compressive modulus.

SUMMARY OF RESULTS

Friction and wear experiments of nine selected polymers with various fillers in sliding contact with 17-4 pH in liquid hydrogen at 2300 feet per minute (701 m/min) and 1 kilogram load gave the following results:

1. PTFCE (with 15- and 25-weight-percent glass fiber or with 15- and 25-weight-percent graphite) showed wear comparable to that of a filled PTFE (15-weight-percent glass fiber + 5-weight-percent graphite) but with friction coefficients approximately 50 percent greater.

2. Addition of PTFE can reduce the wear of polymers. The best example is the 50-percent PTFE powder and 50-percent parapolyphenyl. Wear for the unfilled parapolyphenyl was significantly higher than that for the material containing 50-percent PTFE.

3. Acetal copolymer, parapolyphenyl, and polyimide resins were observed to have lower wear than PTFE (no filler); the friction coefficient, however, for polyimide is high (0.5 to 0.7). Also worthy of consideration are acetal polyoxymethylene and FEP which had wear and friction comparable to unfilled PTFE.

4. Wear of polyamide can be reduced by a factor of about 20 with 60-weight-percent graphite.

5. Although the polymers and polymer composites do not have lower friction and wear than filled PTFE, they do have better thermal stability, less creep, and higher compressive modulus and therefore may be more useful than filled PTFE for some applications.

Lewis Research Center,
National Aeronautics and Space Administration,
Cleveland, Ohio, November 6, 1968,
129-03-13-07-22.

REFERENCES

1. Scibbe, Herbert W.; and Anderson, William J.: Evaluation of Ball-Bearing Performance in Liquid Hydrogen at DN Values to 1.6 Million. Trans. ASLE, vol. 5, no. 1, Apr. 1962, pp. 220-232.
2. Wisander, Donald W.; Ludwig, Lawrence P.; and Johnson, Robert L.: Friction and Wear in Cryogenic Liquids for Composites of Phenolic and of Polytetrafluoroethylene of Various Particle Sizes and Concentrations. NASA TN D-4565, 1968.
3. Rempe, W. H., Jr.: Research and Development of Materials for Use as Lubricants in a Liquid Hydrogen Environment. Trans. ASLE, vol. 9, no. 3, July 1966, pp. 213-221.
4. Wisander, Donald W.; Ludwig, Lawrence P.; and Johnson, Robert L.: Wear and Friction of Various Polymer Laminates in Liquid Nitrogen and In Liquid Hydrogen. NASA TN D-3706, 1967.
5. Anon.: Properties of "Teflon" at Cryogenic Temperatures. J. Teflon, vol. 8, no. 2, Mar.-Apr. 1967, pp. 4-7.

6. Christopher, William F.; and Fox, Daniel W.: Polycarbonates. Reinhold Publ. Corp., 1962.
7. Floyd, Don E.: Polyamide Resins. Second ed., Reinhold Publ. Corp., 1966.
8. Carson, Robert W.: A Special Review of All Self-Lubricated Bearings. Product Eng., vol. 35, no. 8, Apr. 13, 1964, pp. 79-90.
9. Anon.: Moly Disulfide Fillers Reduce Wear in Plastics. Materials and Methods, vol. 45, no. 1, Jan. 1957, pp. 148-149, 151.
10. Mack, Kenneth J.: Evaluation of Self-Lubricating Plastics for Bearings. Preprint No. EM67-130, ASTM, 1967.
11. Baer, Eric, ed.: Engineering Design for Plastics. Reinhold Publ. Corp., 1964.
12. Steijn, R. P.: Friction and Wear of Plastics. Metals Eng. Quart., ASM, vol. 7, no. 2, May 1967, pp. 9-21.
13. Merchant, M. E.: Friction and Adhesion. In NASA Symposium on Interdisciplinary Approach to Friction and Wear. NASA SP-181, 1968.
14. Wisander, D. W.; and Johnson, R. L.: A Solid Film Lubricant Composition for Use at High Sliding Velocities in Liquid Nitrogen. Trans. ASLE, vol. 3, no. 2, 1960, pp. 225-231.
15. Chapman, Frank M.: Properties and Applications of Reinforced Teflon. Machine Design, vol. 30, no. 19, Sept. 18, 1958, pp. 148-154.