

**Hamilton  
Standard**

**U**  
DIVISION OF UNITED AIRCRAFT CORPORATION  
**A®**

NASA CR-134521  
HSER 6241

APR 16 1974

**FINAL REPORT**

**IMPACT RESISTANCE OF SPAR-SHELL COMPOSITE FAN BLADES**

**BY**

**J. GRAFF, L. STOLTZE AND E. M. VARHOLAK**

**HAMILTON STANDARD DIVISION  
UNITED AIRCRAFT  
WINDSOR LOCKS, CONNECTICUT 06096**

**PREPARED FOR**

**NATIONAL AERONAUTICS AND SPACE ADMINISTRATION**

**JULY, 1973**

**DISTRIBUTION STATEMENT A**

Approved for public release;  
Distribution Unlimited

**CONTRACT NAS3-16778**

**NASA LEWIS RESEARCH CENTER  
CLEVELAND, OHIO  
R. H. JOHNS, PROJECT MANAGER**

**19960418 092**

**DTIC QUALITY INSPECTED &**

20298

# DISCLAIMER NOTICE

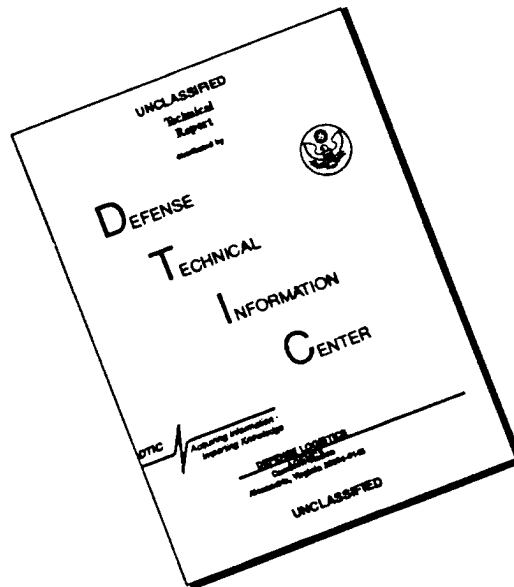

THIS DOCUMENT IS BEST QUALITY AVAILABLE. THE COPY FURNISHED TO DTIC CONTAINED A SIGNIFICANT NUMBER OF PAGES WHICH DO NOT REPRODUCE LEGIBLY.

1. Report No. NASA CR-134521		2. Government Accession No.		3. Recipient's Catalog No.	
4. Title and Subtitle Impact Resistance of Spar-Shell Composite Fan Blades				5. Report Date July 1973	
				6. Performing Organization Code	
7. Author(s) J. Graff, L. Stoltze, and E. M. Varholak				8. Performing Organization Report No. HSER 6241	
				10. Work Unit No.	
9. Performing Organization Name and Address Hamilton Standard Division of United Aircraft Corp. Windsor Locks, CT 06096				11. Contract or Grant No. NAS3-16778	
				13. Type of Report and Period Covered Contractor Report	
12. Sponsoring Agency Name and Address National Aeronautics and Space Administration Washington, DC 20546				14. Sponsoring Agency Code	
15. Supplementary Notes Project Manager, Robert H. Johns, Materials and Structures Division, NASA-Lewis Research Center, Cleveland, Ohio 44135					
16. Abstract  Five composite spar-shell fan blades for a 1.83 meter (6 feet) diameter fan stage were fabricated and tested in a whirling arm facility to evaluate foreign object damage (FOD) resistance. The blades were made by adhesively bonding boron-epoxy shells on titanium spars and then adhesively bonding an Inconel 625 sheath on the leading edge. The rotating blades were individually tested at a tip speed of 800 feet per second. Impacting media used were gravel, rivets, bolt, nut, ice balls, simulated birds, and a real bird. Incidence angles were typical of those which might be experienced by STOL aircraft.  The tests showed that blades of the design tested in this program have satisfactory impact resistance to small objects such as gravel, rivets, nuts, bolts, and two inch diameter ice balls. The blades suffered nominal damage when impacted with one-pound birds (9 to 10 ounce slice size). However, the shell was removed from the spar for a larger slice size.					
17. Key Words (Suggested by Author(s)) Composite Fan Blades Spar-Shell Blades Foreign Object Damage (FOD) Boron-Epoxy Ice Ball Gelatin Ball				18. Distribution Statement  Unclassified - unlimited	
19. Security Classif. (of this report) Unclassified		20. Security Classif. (of this page) Unclassified		21. No. of Pages 42	22. Price* \$3.00

\* For sale by the National Technical Information Service, Springfield, Virginia 22151

**Hamilton  
Standard**

**U**  
DIVISION OF UNITED AIRCRAFT CORPORATION  
**A®**

NASA CR-134521  
HSER 6241

FOREWORD

The work described herein was conducted by Hamilton Standard Division, United Aircraft Corporation, under NASA Contract NAS3-16778 with Mr. R. H. Johns, NASA-Lewis Research Center, as Project Manager.

SUMMARY

Composite fan blades designed for a 1.83 meter (6 foot) diameter Q-Fan<sup>TM</sup> disc were fabricated and were subjected to foreign object damage tests to determine their structural integrity when exposed to various impact media. Principal elements of blade construction consisted of boron/epoxy shells, a titanium spar and an Inconel 625 leading edge sheath. These elements were adhesively bonded into a structural assembly. Five blades were evaluated; one with 0.6 cm (0.25 inch) gravel, nuts, bolts and 0.3 cm (0.125 inch) rivets, one with 5.08 cm (2 inch) diameter iceballs, one with a 454 gram (1.0 pound) simulated bird, another with a 909 gram (2.0 pound) simulated bird and the fifth with a 499 gram (1.1 pound) real bird.

Tests were performed in a vertical whirl rig at 0.24 meters (9.5 inches) of Hg. atmosphere with a tip speed of 877.6 km/hr (800 feet per second) and an incidence angle of 0.625 radians (35.8 degrees) to the plane of rotation. Pre- and Post-test inspections were performed on the blades including Fokker bond tests of adhesive joints, tracings of airfoil sections and frequency testing of blades in the first and second flatwise mode and the first torsional mode.

Testing was successfully completed with only the bird impacts causing significant damage to the test blades. Minor surface damage was noted on the first two blades as a result of the gravel and assorted hardware and iceballs. Frequency check of these two blades reflected no significant change. Impact of the 454 gram (1.0 pound) simulated bird resulted in some interlaminar delaminations of the shell and slight distortion of the leading edge sheath. The 909 gram (2.0 pound) simulated bird (slice size 11 ounces) impact removed the shell and sheath from the spar with no damage being sustained by the spar and its retention. A repeat of the 454 gram (1.0 pound) bird test was made with a real bird, a chukar partridge. Evaluation of this blade revealed less interlaminar damage in the shell with more leading edge distortion of the sheath. Frequency comparison of the blades used in these two tests reflected less change in the blade struck by the partridge in all three modes; a reduction of 10% in first torsional as compared to 16% for the blade hit with the simulated bird, 3.4% versus 6% in first flatwise mode and 2.9% versus 3.8% in the second flatwise modes.

It is concluded that the basic design is capable of withstanding bird impacts up to approximately 454 grams (one pound). The simulated bird (gelatin) test resulted in more gross blade damage than the real bird impact with the latter causing a more localized distress than the simulated bird. Blade fracture occurred interlaminarily in the shell and was closely related to the interlaminar shear and peel properties of the epoxy matrix used in the blade. Increase of the spar chordal width within the shell to reduce moment loads at the shell-to-spar juncture and a change to metal matrix composite having much improved interlaminar properties should significantly improve the FOD resistance of the blade.

## INTRODUCTION

Recent advances in the design of aircraft propulsion systems have emphasized the need for improved materials capabilities. These improvements are necessary to provide projected fan blade weight and structural performance. Advanced composites featuring high specific strength and modulus offer the potential for a major contribution in this area. However, performance of these materials in the appropriate environmental conditions must be assessed. An extremely important area, resistance to foreign object damage (FOD) must be verified. The objective of this program was to establish the structural capability of a current Hamilton Standard spar and shell Q-Fan blade design to resist foreign object damage in several impact environments. These included stones, iceballs, nuts, bolts, rivets, simulated birds and real birds.

The program consisted of three phases, fabrication of Q-Fan blades, impact testing in a whirl facility, and detailed evaluation of the blades to determine the effect of the impacts on structural integrity.

Five contract fan blades were fabricated for test. These tests were conducted in a whirl cell at Hamilton Standard designed to inject the various impact media in a repeatable fashion. High speed movies were made to verify the impact. Test parameters were selected to simulate an aircraft climb condition at take-off speed. Of the five blades, two were impacted by the smaller media, two by gelatin simulated birds and one by a real bird, a chukar partridge.

The test evaluation reported herein indicates the capability of a particular spar and shell Q-Fan blade design in an impact environment. Damage resulting from small impact media was not significant. Impact with simulated and real birds weighing up to approximately 454 grams (1 pound) caused moderate damage, but left the blade apparently still able to continue its function. Design and/or material improvements to the blade will be required to withstand bird impacts in excess of 454 grams (1 pound).

## TEST BLADES

Five test blades, representative of a 1.83 meter (6 foot) diameter STOL type Q-Fan stage were manufactured for foreign object damage evaluation. This specific blade is composed of three major elements, a spar, a shell and a leading edge protection sheath, Figure 1. The basic design of this blade was established during an earlier program to fabricate reduced noise demonstration blades.

The spar is a solid 6 Al-4Vn titanium structure with an integral circular retention. This retention forms a part of the variable blade pitch system which is a feature of the 1.83 meter Q-Fan blade design. The dimensions of the spar were maintained within the original design envelope and thus, the chordal width of the spar was restricted to about 25% of the blade chord width instead of the wider spar of our current design criteria.

The shell was manufactured from boron/epoxy material, which was obtained from an industrial processor, in tape form approximately 7.62 cm (3 inches) wide. The boron fibers were 0.0144 cm (0.0056 inch) in diameter and impregnated with epoxy resin of the type listed in Figure 2. The fiber spacing in the tape was nominal 59 filaments per cm (150 filaments per inch) of width of sheet. Data from vendor composite tape verification tests are shown in Table I.

The face and camber halves of the shell consist of 15 layers of material oriented as listed in Figure 2. Each shell half is laid up by hand on a female die half and cured in an auto-clave, to the cycle given in Figure 2.

The leading edge erosion sheath for the blade is of three-piece construction and is made of Inconel 625 nickel stainless steel as shown in Figure 3. The chordwise extent of the sheath on the face (pressure) side of the blade is greater than of the camber side in recognition of the normal service erosion patterns. The leading edge is solid for maximum durability in stone and rivet impact and to provide some blendability for local repairs of nicks which may occur in service.

The elements are structurally bonded with a thermosetting modified epoxy film adhesive, 3M AF126. The shells are bonded to the spar in the first step of assembly and the sheath to the shell/spar assembly in a second operation. Cure time is 1 1/2 - 1 3/4 hours at 392°K - 400°K (245 - 260° F).

The shell cavities, lead and trail, are filled with a rigid urethane foam to provide a light weight filler material. These materials are listed in Table II.

Quality Assurance provisions were maintained during the processing of the blades. X-ray, Fokker bond test, visual examination and airfoil tracings were conducted during fabrication of the blades culminating with a frequency test of the blades prior to impact testing. These records provided a basis for comparison of the blades during post test inspection.

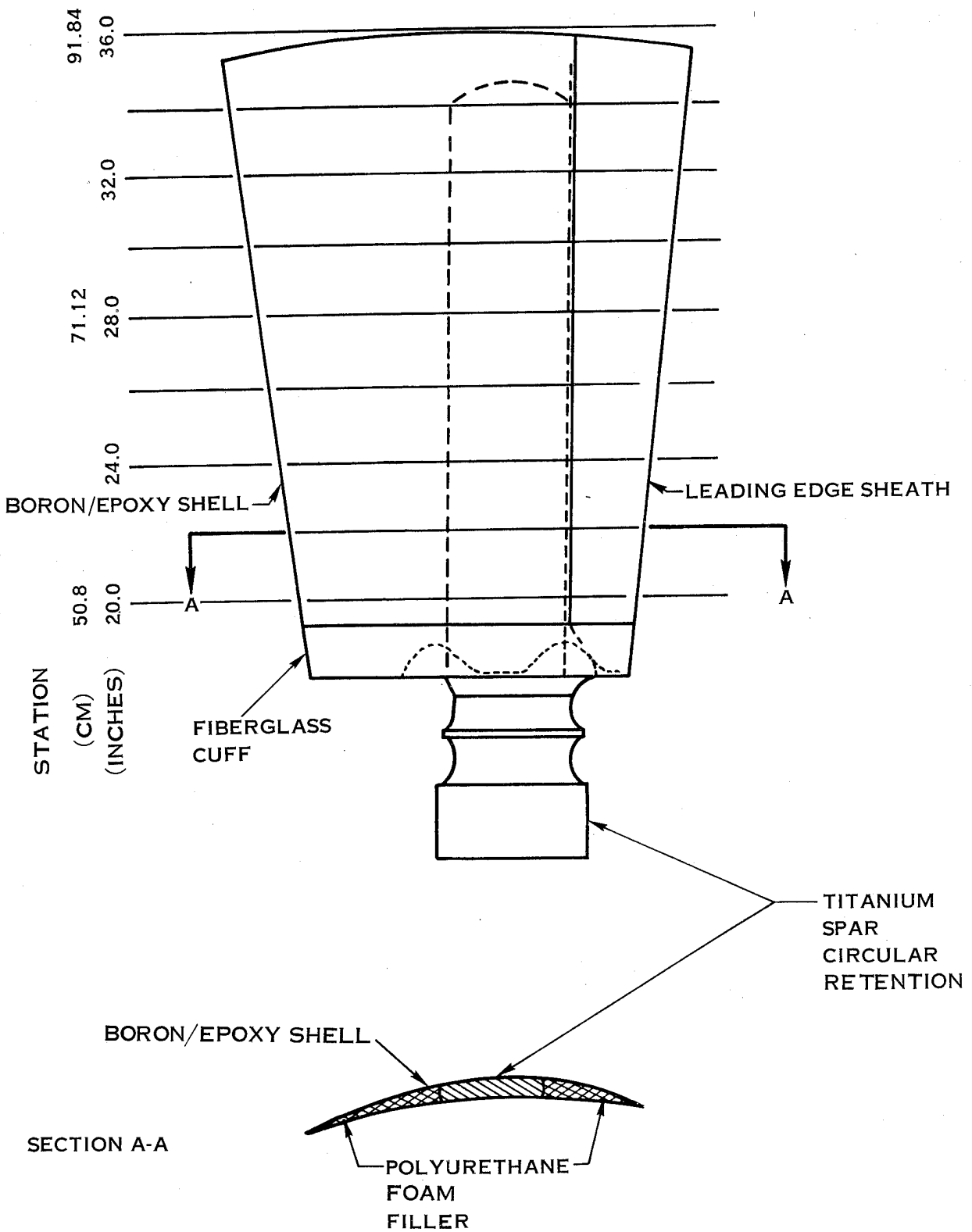
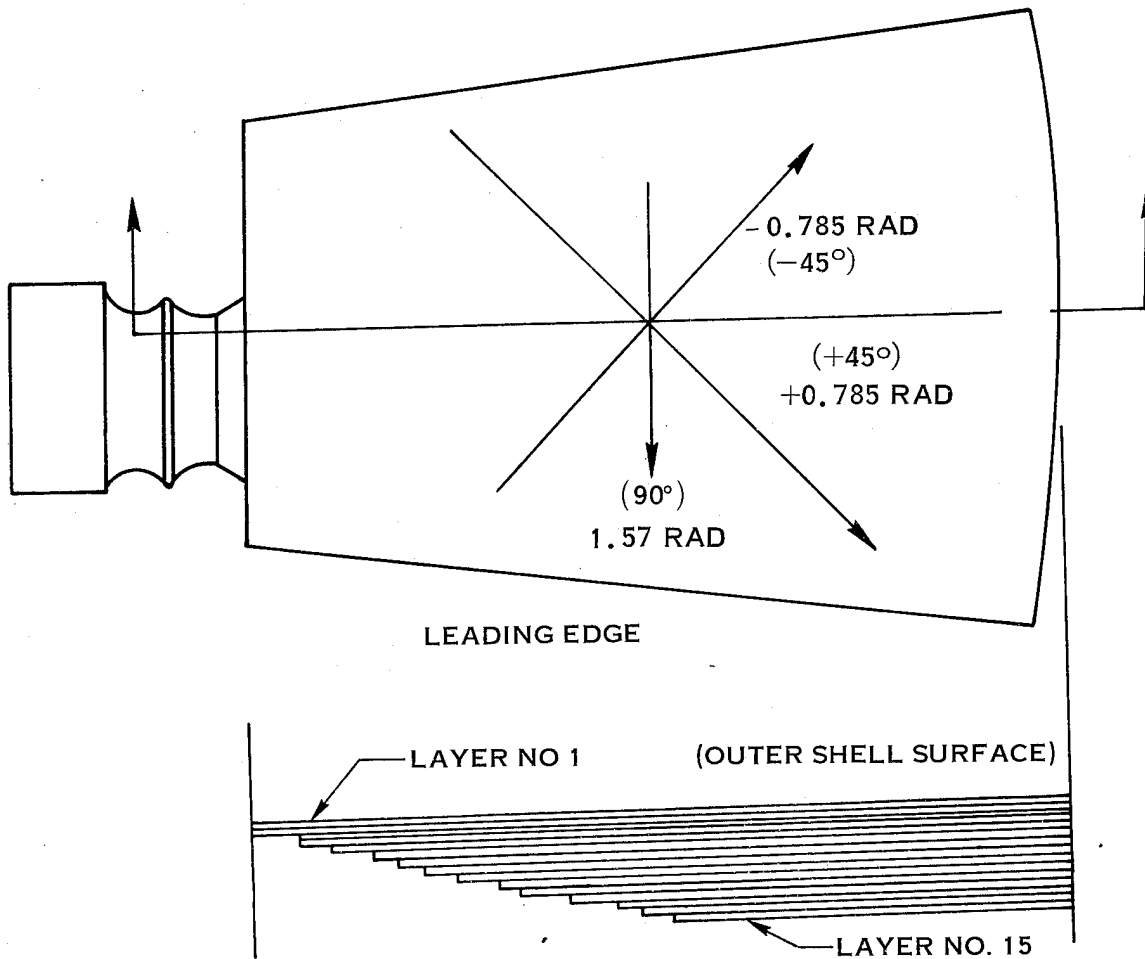

FIGURE 1. 1.83M DIAMETER Q-FAN TEST BLADE



LAYER NO.	1	2	3	4	5	6	7	8	9	10	11	12	13	14	15
ORIENTATION DEGREES	+45°	-45°	+45°	-45°	90°	90°	+45°	90°	90°	-45°	90°	90°	+45°	90°	90°
RADIANS	+.785	-.785	+.785	-.785	1.57	1.57	+.785	1.57	1.57	-.785	1.57	1.57	+.785	1.57	1.57

MATERIAL: 3M PRODUCT TYPE SP-292 (5, 6) BORON-EPOXY  
PREPREG TAPE

EXPOSURE CONDITIONS FOR RESIN CURE OF SHELL:

AUTOCCLAVE PROCESS 586 KN-M<sup>2</sup> - 655 KN-M<sup>2</sup> (85 - 95 PSI) CURE 440 - 456° K  
(340 - 360° F) FOR 80 - 90 MINUTES, COOL AND POSTCURE SHELL IN OVEN  
FOR 4 - 6 HRS. AT 440° - 456° K (340 - 360° F)

FIGURE 2. SHELL DETAILS - ORIENTATION AND CURING CONDITION

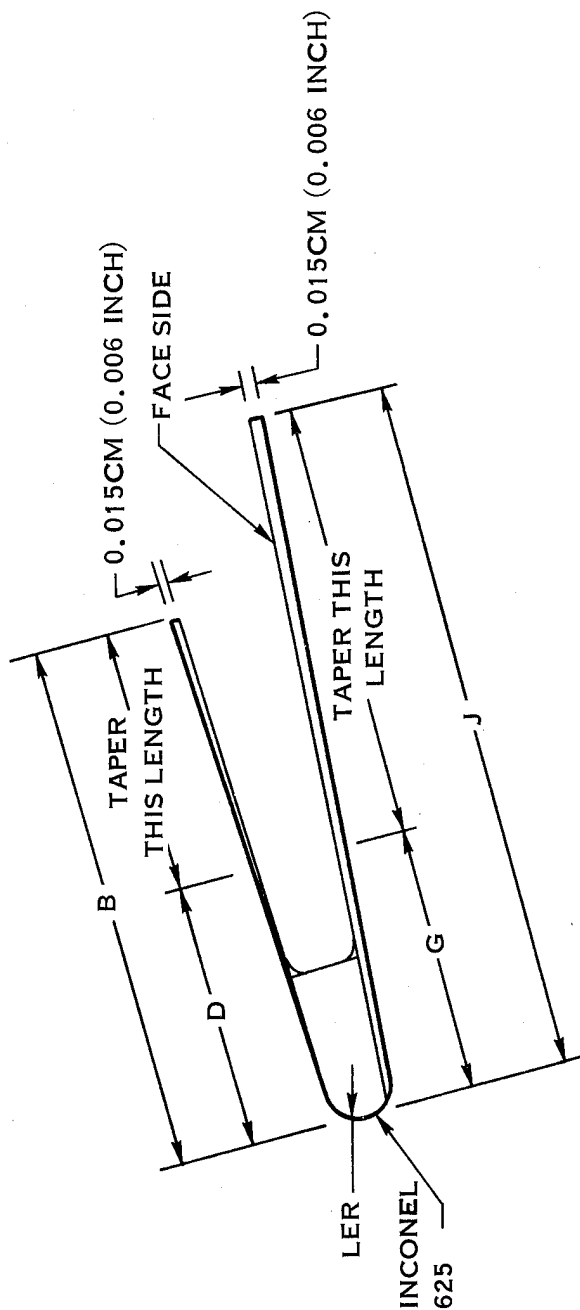

STATION	B		D		G		J		LER	
	CM	INCH	CM	INCH	CM	INCH	CM	INCH	CM	INCH
45.72	18.0	4.9	1.928	1.132	2.88	1.134	4.495	1.770	.086	.034
60.96	24.0	5.35	2.108	1.134	2.87	1.132	5.842	2.300	.086	.034
71.12	28.0	5.59	2.202	1.136	2.885	1.136	7.328	2.885	.086	.034
81.28	32.0	6.55	2.580	1.138	2.89	1.138	7.938	3.125	.086	.034
91.44	36.0	6.97	2.744	1.140	2.895	1.140	8.600	3.386	.086	.034

FIGURE 3. LEADING EDGE SHEATH—PHYSICAL DIMENSIONS

TABLE I VENDOR COMPOSITE VERIFICATION TESTS

EPOXY-BORON PREPREG TAPE - SCOTCHPLY TYPE SP-292 (5.6)

3M Company - Industrial Specialties Division

Quality Control Lot Acceptance Data

Applicable Specification: of 3M Company for SP-292 0.014 cm(5.6 mil) boron

Date Tabulated: 3-19-73

Product Mfg. Code: 51363. Lot-275

Tabulated By: J. A. Curtis

SPACING: OK BROKEN FIBERS: OK DIMENSIONS: OK

UNIFORMITY: A roll defect log is attached to each roll. WORKMANSHIP: OK

<u>PHYSICAL PROPERTIES:</u>	<u>ROLL #1</u>	<u>ROLL #8</u>
Tack	<u>OK</u>	<u>OK</u>
Flow	<u>16%</u>	<u>15%</u>
Volatiles	<u>0.4%</u>	<u>0.4%</u>
Resin Content	<u>30%</u>	<u>32%</u>

MECHANICAL PROPERTIES -MN/m<sup>2</sup> (KSI):

0° Flexural Strength @ RT	<u>1969 (281.9)</u>	<u>1886.4 (273.6)</u>
0° Flexural Modulus @ RT	<u>NA</u>	<u>NA</u>
0° Flexural Strength @ 450°K (350° F)	<u>1584 (229.8)</u>	<u>1556.9 (225.8)</u>
0° Flexural Modulus @ 450°K (350° F)	<u>NA</u>	<u>NA</u>
Trans. Flexural Strength @ RT	<u>82.1 (11.9)</u>	<u>88.26 (12.8)</u>
Trans. Flexural Strength @ 450°K (350° F)	<u>56.5 (8.19)</u>	<u>61.02 (8.85)</u>
Horiz. Shear Strength @ RT	<u>108.3 (15.7)</u>	<u>107.56 (15.6)</u>
Horiz. Shear Strength @ 450°K (350° F)	<u>61.78 (8.96)</u>	<u>60.89 (8.83)</u>

TABLE II  
POLYURETHANE FOAM FILLER  
USED IN Q-FAN SPAR AND SHELL TEST BLADES

Location	<u>Lead Edge Cavity</u>	<u>Trail Edge Cavity</u>
Material *	15-L-322	15-L-316
Viscosity (RT)		
Component A	2.4-2.2 Ns/m <sup>2</sup> (2400-2800 cps)	2.0-2.4 Ns/m <sup>2</sup> (2000-2400 cps)
Component B	4.8-5.4 Ns/m <sup>2</sup> (4800-5400 cps)	3.8-4.2 Ns/m <sup>2</sup> (3800-4200 cps)
Free blow core density	32 Kg/m <sup>3</sup> - 41.6 Kg/m <sup>3</sup> (20-26 lb/ft <sup>3</sup> )	19.2 Kg/m <sup>3</sup> - 28.8 Kg/m <sup>3</sup> (12-18 lb/ft <sup>3</sup> )
Minimum compressive strength for core density range	7.8 MN/m <sup>2</sup> - 10.5 MN/m <sup>2</sup> (1125-1520 psi)	3.3 MN/m <sup>2</sup> - 5.4 MN/m <sup>2</sup> (480-790 psi)
Minimum modulus for core density range	231 MN/m <sup>2</sup> - 300 MN/m <sup>2</sup> (33,500-43,500 psi)	98 MN/m <sup>2</sup> - 14.7 MN/m <sup>2</sup> (14200-21300 psi)
Processing Data		
Mixing ratio, by weight A/B	100/77	100/75.5
Mixing time	60-230 sec	60-230 sec
Demold time	3 to 4 hrs	3 to 4 hrs
Post cure	1 hr @ 322°K (120°F) or, 0.5 hr @ 353°K (175°F)	1 hr @ 322°K (120°F) or, 0.5 hr @ 353°K (175°F)

\* General Latex and Chemical Corporation

### TEST FACILITY

The impact testing was conducted in Hamilton Standard's "G-5" whirl test facility shown in Figure 4. This facility is a fully contained sealed chamber powered by a 500 hp electric motor. To minimize power requirements, cell heatup and windage effects, the cell was evacuated during testing to approximately 0.24 meter (9.5-inch) Hg absolute pressure.

The test blade was attached to a propeller barrel assembly through an adaptor designed to rotate the test blade at the designated tip diameter and speed. The propeller was reworked to provide mechanically fixed blade angle operation and it was set up in a single blade configuration. In the remaining three propeller barrel arms, counterweight bars were installed. These were short enough to provide radial clearance between the bar tips and the impact media.

All testing was recorded by high speed photography. Photographs were taken with a Fastax high speed movie camera located as shown in Figure 4B. Film speed was approximately 2800 frames per second for the small media tests and 4900 frames per second for the simulated and real bird impact tests.

Two injection systems were used in this program. For small media (stones, rivets, nuts, bolts and iceballs), the chute injection system shown in Figure 4A was used. The impact media were initially placed in a cavity in the back end of the chute. An internal retaining plate, upon solenoid release, rotated 90° to allow the media to gravity drop into the blade plane. During iceball tests, dry ice was installed in the cavity surrounding the back end of the chute to maintain 273.3°K (32°F) maximum temperature.

For simulated and real bird injection, the media were delivered to the impact site on a pendulum-like carrier shown in Figure 4B. The pendulum was initially held in a horizontal position by an electromagnet. The release of the pendulum was controlled by a programmable time delay circuit. From a knowledge of the blade speed and pendulum drop time, the time delay required was calculated and set into the time delay counter. This delay synchronized the arrival of the bird and the blade to obtain the desired impact slice. A clutching system prohibited the bird from impacting the blade a second time.

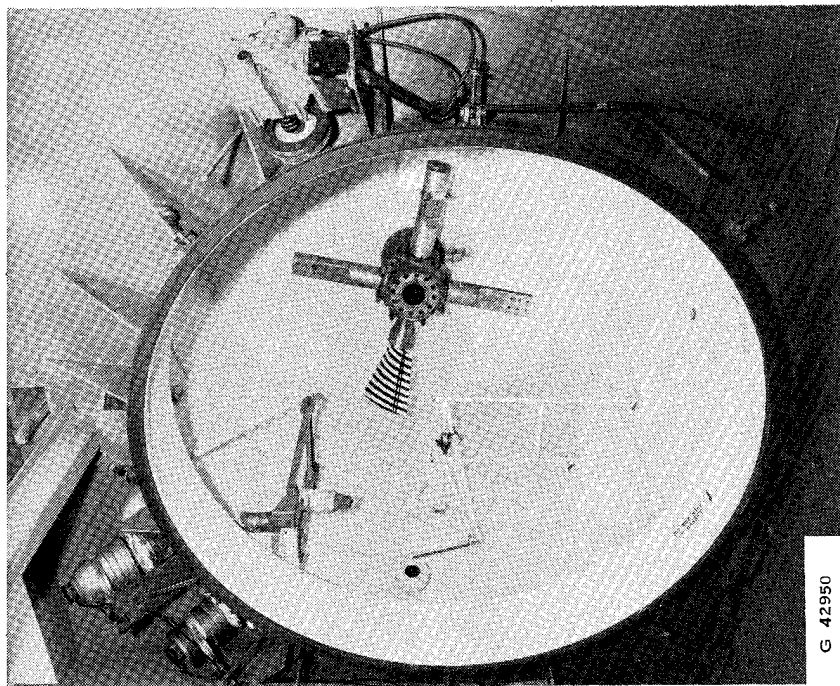

B) FOD BIRD DELIVERY ASSEMBLY

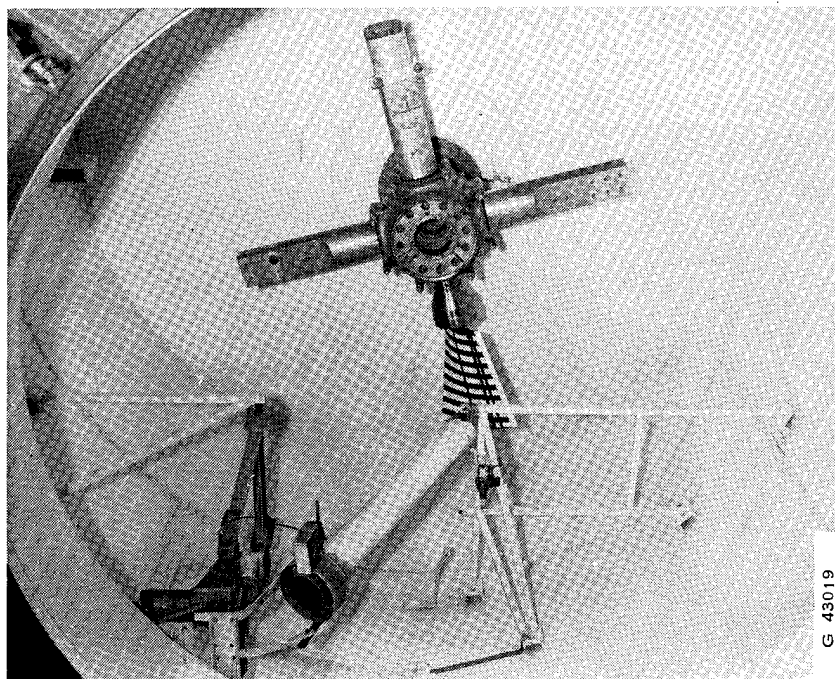

A) SMALL FOD MEDIA ASSEMBLY

FIGURE 4. G-5 WHIRL TEST FACILITY

IMPACT MEDIA

The small impact media used in this program are listed in Table III. The selection of stones, rivets, nuts, bolts and iceballs was made to establish the capability of the blade to resist damage from a variety of typical impact media. The type of stones used in this program had been used at Hamilton Standard in tests on propeller blades, fan blades and blade specimens and was obtained from a lake bed at Edwards Air Force Base in California. As shown in Figure 5, the stones were sharp edged. In tests of blades at Edwards, gouging effects due to stone impact on fiberglass blade surfaces unprotected by the leading edge sheath were severe. The nuts, rivets, and bolts that were impacted, as well as unimpacted stones, are shown in Figure 5. The iceballs used in this program were molded from supersaturated carbonic acid to obtain the 0.80 to 0.85 specific gravity range typical of hail. The fabrication procedure is defined in Appendix B.

Two types of specimens were used to evaluate large impact effects on fan blades. Simulated birds consisting of a nominal 20% by weight gelatin mixture was one of these. The gelatin provided the means to conduct controllable impact experiments. Response of the gelatin proved very similar to real birds in tests conducted by the British.<sup>1</sup> This correlation was noted during this program as well.

Figure 6A describes the complete simulated bird ready for attachment to the pendulum. The internal restrictions in the aluminum casing and the low density, styrofoam 32.04 Kg/m<sup>3</sup> (2 lb/ft<sup>3</sup>) outer support were included to minimize gelatin inertial stretch and lateral deformation especially after the pendulum contacted the stops at the completion of its swing. The two simulated bird sizes differed primarily in the diameter of the bird. The same "bite" was required to impact the proper bird weight for either.

The second large impact media was a real bird. Figure 6C also describes this assembly. The bird was a 499 gram (1.1 pound) chukar partridge (Figure 7) selected for weight on the basis of the results of the simulated bird tests. The frozen bird was thawed overnight prior to use in the test. Aluminum casings and styrofoam were used to mount the bird to the pendulum and to support the partridge. The bird was placed in a nylon bag with head held snugly against the body. The bird was installed for head first injection. The styrofoam casing was sized for a snug fit between bird and foam. The feet were attached by wire to the foam casing.

<sup>1</sup>Reference: The Development of a Dummy Bird for use in Bird Strike Research By A.W.R. Allecock and D.M. Collin; National Gas Turbine Establishment (C.P. No. 1071, June 1968)

TABLE III  
SMALL IMPACT MEDIA FOR FOD TESTING

<u>Stone</u>	Source - dry lake bed, Edwards Air Force Base, California Quantity injected - 30 Specific gravity - 2.68 Total weight injected - 6.15 gm (0.014 pound) Average stone weight - 0.205 gm (0.0004 pound) Stone size - 0.64 cm (1/4 inch)
<u>Rivet</u>	Quantity injected - 3 Material - aluminum Part Number - MS20470AD5-8 Total weight injected - 1.8 gm (0.004 pound) Average rivet weight - 0.6 gm (0.0013 pound) Rivet size - 0.397 cm dia. x 1.27 cm long (4/32 inch dia x 1/2 inch)
<u>Self Locking Nut</u>	Quantity injected - 1 Material - steel Part number - 69949 Total weight injected - 3.55 gm (0.0078 pound) Nut size - 0.64 cm -28 (1/4 inch - 28)
<u>Socket Head Capscrew</u>	Quantity - 1 Material - steel Part number - 69905 Total weight injected - 7.6 gm (0.0167 pound) Bolt size - 0.64 cm -28 x 2.54 cm (1/4 inch - 28 x 1.0 inch)
<u>Iceballs</u>	Quantity injected - 2 Material - super saturated carbonic acid Specific gravity - 0.80 - 0.85 1st iceball weight - 58.8 gm (0.129 pound) 2nd iceball weight - 54.6 gm (0.12 pound) Iceball size - 5.08 cm diameter (2 inch)



FIGURE 5. SMALL IMPACT MEDIA FOR FOD TESTING

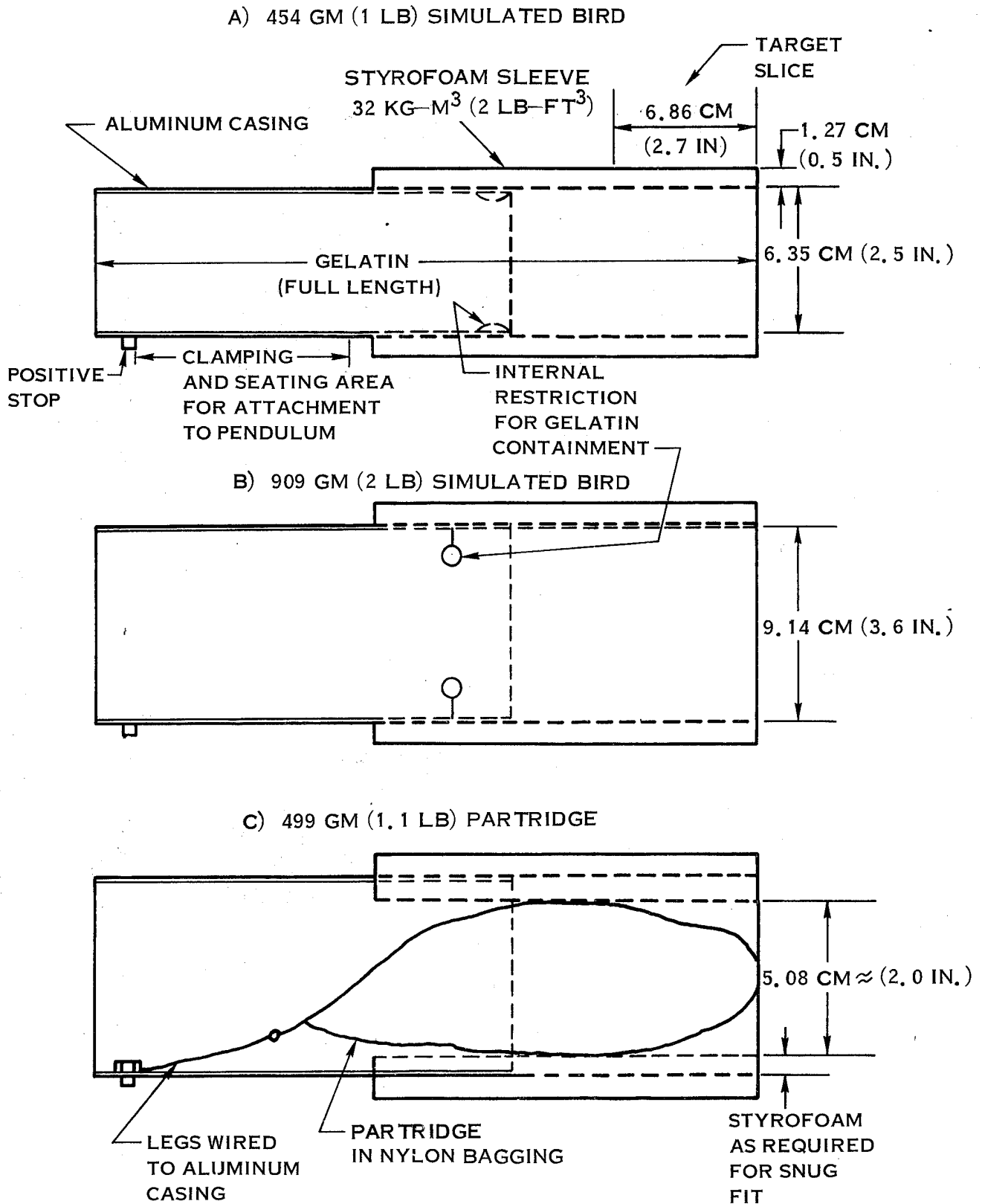
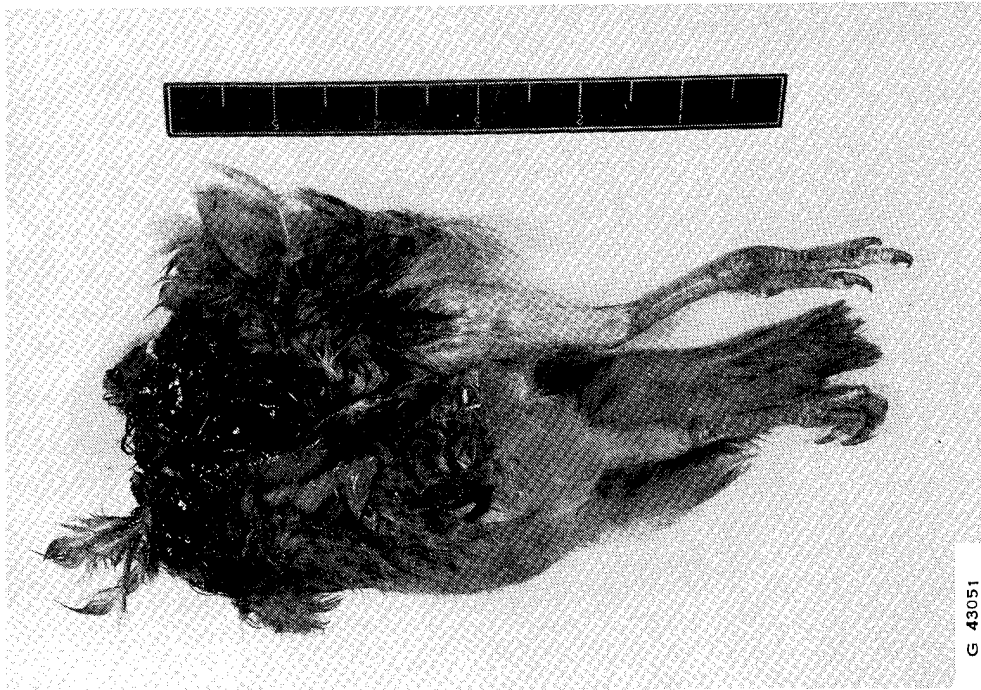
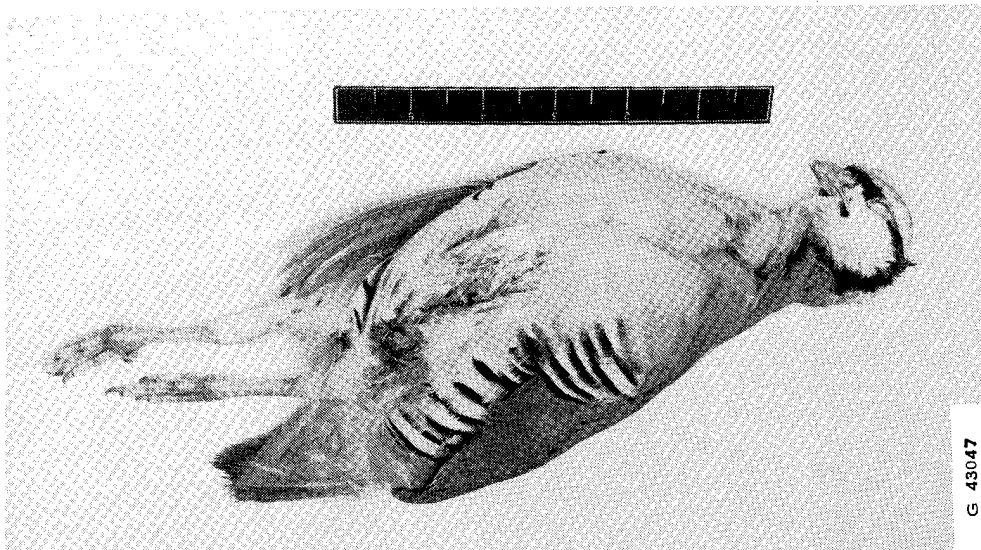

FIGURE 6. BIRD SCHEMATIC FOR FOD TESTING



**B) POST TEST CONDITION**  
**WEIGHT 222 GM (0.50 LB)**



**A) PRE TEST CONDITION**  
**WEIGHT 499 GM (1.1 LB)**

**FIGURE 7. CHUKAR PARTRIDGE USED IN FOD TEST**

TEST PROCEDURES

The tests were conducted in accordance with the Plan of Test, 1-Q-Fan/FOD. A summary of the actual test conditions for each of the tests is presented in Table IV. The nominal conditions for testing of blades are also presented. For all tests, the blade impact target station was at 80% span or 10.2 cm (4.0 inches) inboard of the tip. Nominal blade angle was 0.74 radians ( $42.4^\circ$ ) at the reference station, 20.4 cm (8 inches) inboard of the tip. This was equivalent to 0.62 radians ( $35.8^\circ$ ) at the impact station. Fan nominal speed was 267 rad/s (2550 rpm). Blade angle was determined prior to the test run with a propeller protractor. Reading accuracy was within 0.0017 radian ( $0.1^\circ$ ). Fan speed was determined with a digital counter activated by a magnetic pickup operating off the propeller shaft. This system was accurate within  $\pm 0.052$  rad/s (0.5 rpm). The fan assembly was balanced prior to installation in the test facility. To facilitate high speed movie analysis, 2.54 cm (1 inch) chordwise stripes one at the blade centerline and two representing the sheath trailing edges were painted on the camber side of the blade. For all tests, the impact of the blade was synchronized with the high speed camera to obtain motion picture records of the tests.

For the small impact media, a gravity injection chute was used. A single blade, B-1, was used for stone, rivet, nut and bolt tests. Each of the four media were injected individually, in turn. Chute radial position was adjusted slightly to minimize the risk of superimposing impacts of the rivet, nut and bolt media. Blade B-2, was used for the 5.08 cm (2.0 inch) iceball impact tests. To eliminate melting, the holding section was cooled with dry ice placed in the surrounding ice cavity. Two iceballs were injected at this blade in individual tests. The first provided a 25% hit, and the second a 100% hit

Three blades were used in the bird test portion of the contract. Blade B-3 was hit by a 454 gram (1 pound) gelatin simulated bird, Blade B-5 a 909 gram (2 pound) gelatin simulated bird and blade B-4 a 499 gram (1.1 pound) partridge. The test procedures and conditions were the same as for small media tests with the exception of the injection procedure. To synchronize the blade/bird impact, it was necessary to determine the pendulum drop time. This enabled calculation of the synchronizing time delay to be input into the programmable time delay circuit. Therefore, two pretest timing runs were conducted. These runs were similar to the actual impact runs except that the pendulum stop position was adjusted short of impact. A time increment was added to the average drop time to compensate for the additional pendulum travel which occurred during actual impact.

The specific sequence of events during the test were as follows: The sequence was manually initiated. This started the movie camera, which then ran 0.4 second to accelerate to "on-speed". After 0.4 second and after the blade rotated to a pre-established position as sensed by a magnetic pickup, the delay time count down was electronically initiated. At the end of the count down the pendulum was released and reached the impact site just prior to the blade, approximately 17 propeller revolutions later. Figure 5 shows a cell overview with the blade in the impact position and the

TABLE IV  
BLADE TEST SUMMARY

Blade Designation	Blade Speed		Impact Station Blade Angle	rad	degree	Media Quantity	Impact Media	Media Weight		Slice Weight		% Hit
	rad/s	rpm						lb	gm	lb	gm	
B-1	267	2550	0.627	36.0	30	Stone	0.014	6.2	-	-	90	
	267	2552	0.617	35.4	3	Rivets	0.004	1.8	-	-	100	
	267	2550	0.617	35.4	1	Nut	0.0078	3.6	-	-	100	
	267	2550	0.617	35.4	1	Bolt	0.167	7.6	-	-	100	
B-2	267	2550	0.627	36.0	1	Iceball	0.129	58.8	0.032	14.7	25	
	267	2554	0.627	36.0	1	Iceball	0.12	54.6	0.12	54.6	100	
B-3	262	2501	0.622	35.7	1	Gelatin	1.0	454.0	0.56	255.0	56	
B-5	262	2502	0.634	36.4	1	Gelatin	2.0	909.0	0.70	316.0	35	
B-4	262	2504	0.618	35.5	1	Partridge	1.1	499.0	0.605	277.0	57	

pendulum containing an early gelatin bird configuration, in the armed position. Figure 8 shows a close-up of the pendulum, armed (top view) and in the impact position (bottom view).

To confirm actual slice size, the birds were weighed before and after the test. Figure 9 shows the slice surface of the three birds impacted.

On site tap test was performed before FOD testing to verify the structural integrity of the blade. One blade test, the 909 gram (2.0 pound) gelatin simulated bird test resulted in loss of the shell and the leading edge sheath, approximately 20% of the total blade weight.

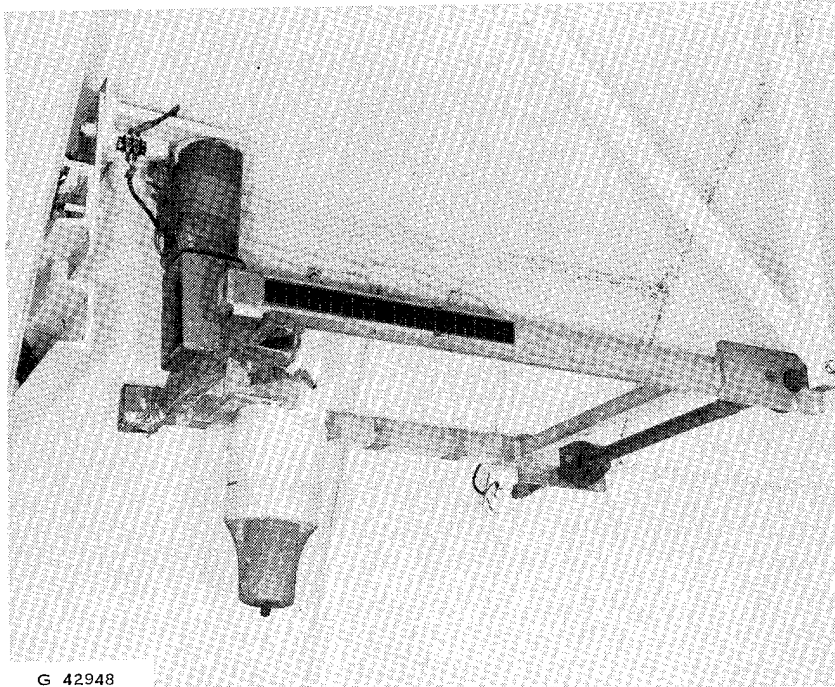

A) PENDULUM IN ARMED POSITION

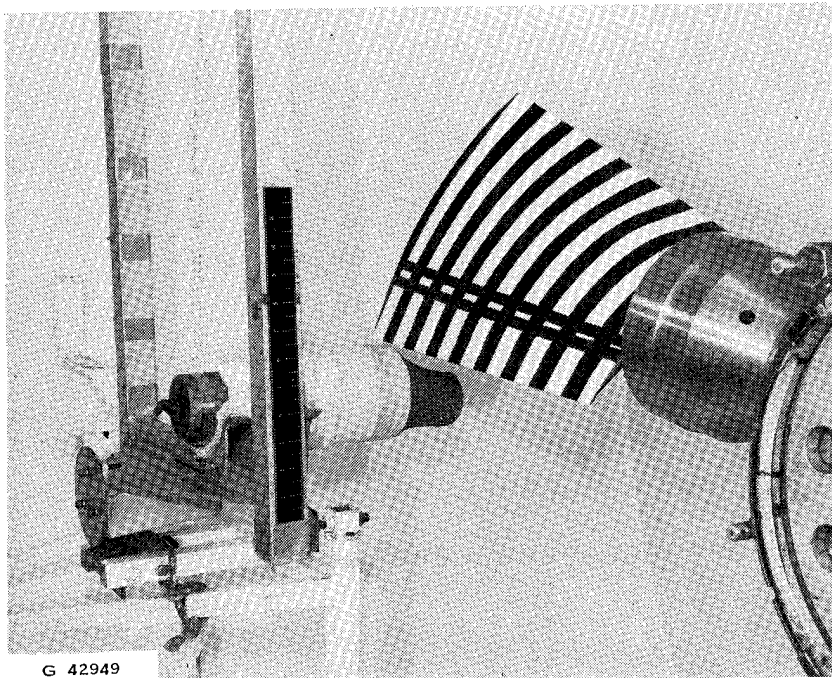

B) PENDULUM AT IMPACT POSITION

FIGURE 8 SIMULATED BIRD ASSEMBLY INSTALLED IN FOD TEST CELL

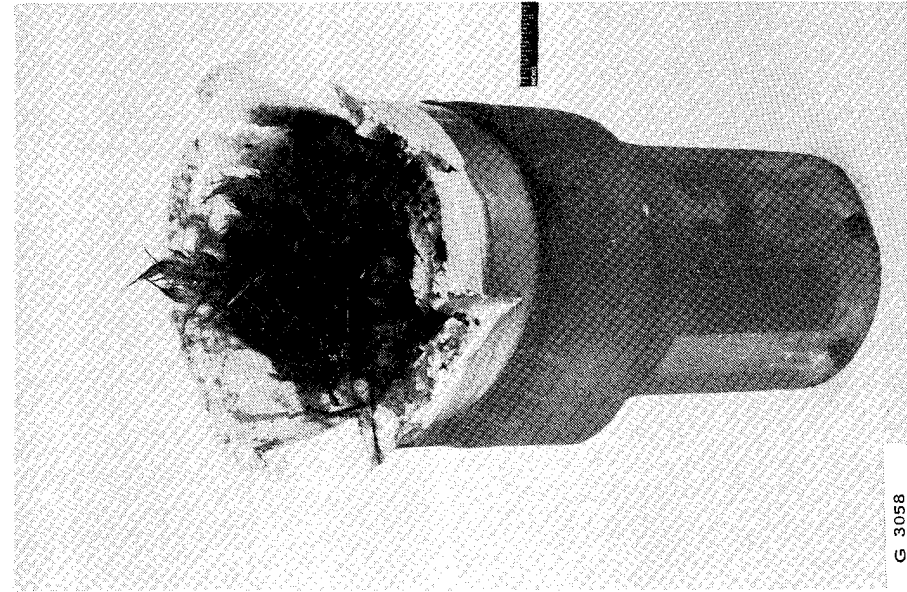

G 43034

A) SIMULATED BIRD —  
454 GM (1.0 LB)

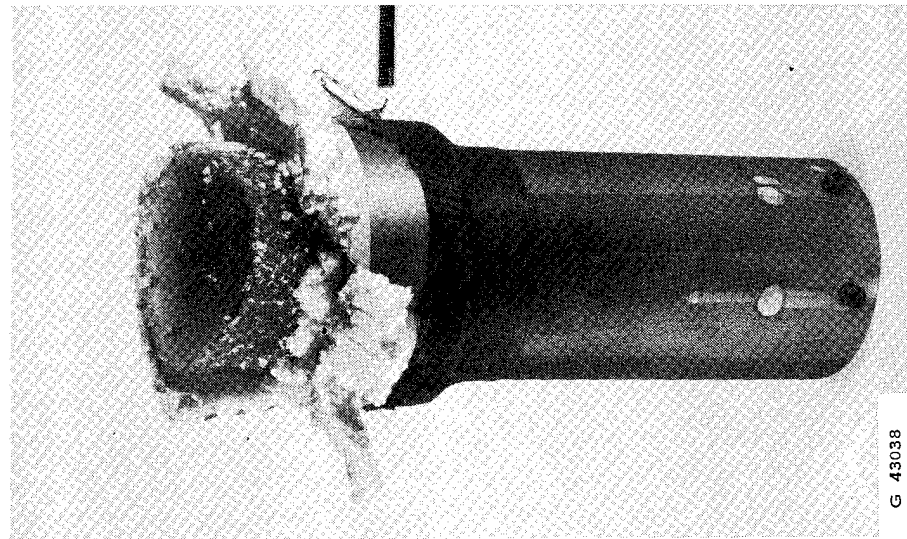

G 43038

B) SIMULATED BIRD —  
909 GM (2.0 LB)

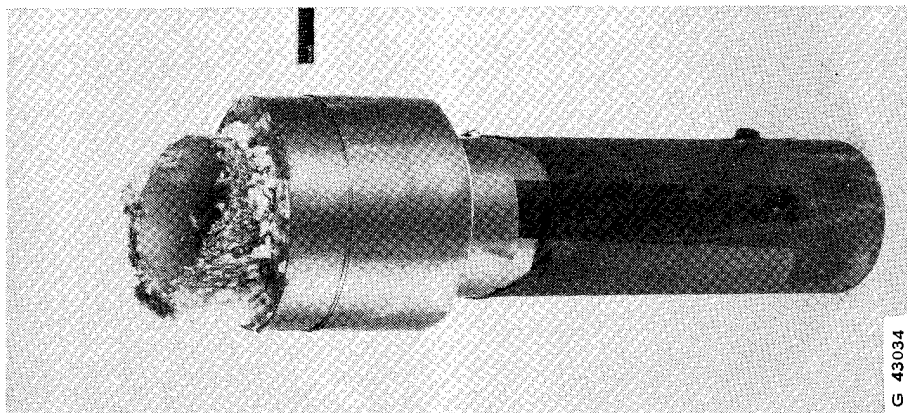

G 3058

C) CHUKAR PARTRIDGE —  
499 GM (1.1 LB)

FIGURE 9. BIRD ASSEMBLIES — POST TEST CONDITION

BLADE FOD EVALUATION

Several evaluation techniques were employed in this program to define the effect of impact on the blade. Both non-destructive and destructive techniques were included. As previously indicated non-destructive tests including x-ray, airfoil plotting, tap test, Fokker bond and blade frequency tests were conducted on the test blades as pre-test documentation. Subsequent to impact testing, these tests were repeated and ultrasonic "C" scan tests performed. Effectivity of these techniques varied as discussed below:

1. X-ray was used to examine filament orientation and alignment and filament continuity in impacted areas. It was also used to examine bond areas for voids. Resolution was found to be very good except for in void detection where contrast was poor.
2. Fokker bond (electronic measurement of damping using ultrasonic waves) was used to examine the spar to shell main adhesive bond and the shell to shell edge bonds. However, this method is particularly dependent on the establishment of a standard. The scope of this contract did not include the large sample size and corresponding destructive evaluation required to exploit this technique. Although the data provided by this method of NDE is informative and may be useful in further development of the process it is inconclusive for these blades.
3. Ultra-sonic "C" Scan (through transmission) was attempted. However, the comments on Fokker bond testing also apply here. The blade is a complex structure and consequently the path for the signal is complex. The resulting scans provided little meaningful information for the set of operating frequencies and attenuations attempted. Therefore, this method is not considered a primary inspection procedure within the scope of this program.
4. Tap testing is a method in which the sounds emitted when the fan blade surface is struck by a steel ball are monitored by ear. Tonal changes in the sound provide an indication as to the structural integrity of the spar-to-shell, shell-to-shell, leading edge sheath-to-shell and the shell-to-foam fill bonds. The method is sensitive to operator skills and interpretation. However, years of experience are available at Hamilton Standard in the use of this technique. The tap test was considered an important non-destructive technique in the post impact evaluation.
5. Dimensional inspections were made prior to and subsequent to impact test. These were performed to assess the extent of airfoil distortion and/or twist occurring as a result of the impact. In addition to the manual inspections using blade airfoil templates, machine tracings of selected spanwise airfoil stations were made on a New England Eyelash Plotter. The machine produces a 3X plot of the airfoil. Comparison of pre- with post-impact airfoil plots permitted assessment of blade deformations and to some extent disbonds (delamination) resulting from the impact.

6. Blade static frequencies were determined before and after the impact tests. The frequencies were determined by installing the blade in a rigid retention. The blade was excited in its natural modes by a cone driver tuned to those frequencies. The resonance was detected on a voltmeter which received its input from an accelerometer attached to the blade. Three frequency modes were recorded, the first and second flatwise and the first torsion. They gave a measure of severity of structural damage especially on the bird impact blades.

Destructive evaluation was conducted selectively on blades in which internal damage was indicated by non-destructive test. Prior to sectioning, small holes were drilled in the composite shell within areas of known disbonds. The blade was subsequently soaked in a fluorescent liquid die to saturate the entire disbond area. The soaked blade was subsequently oven dried. After drying, the composite shell was cut selectively by diamond routing until the area of disbond was uncovered.

Data showing deviation from that of pretest is presented in the following description of the blade structural effects caused by the impacts. These data are based on the non-destructive tests previously described. Additional destructive examination was conducted in the bird impact blades. This is also presented in this section.

#### Blade B-1 - Small Media Impact Tests

This blade was subjected to impact with four types of foreign objects in consecutive test runs. These were stone, rivets, nut and capscrew. Specific characteristics of these media are presented in Table III. There was no internal structural damage. Surface indications are noted below. The blade was sprayed with a flat white paint prior to each of the test runs in this series to facilitate identification of marks or damage made by the subsequent media test.

1. Stone test - The paint was blemished at the impingement sites. Indentions on the immediate leading edge extended to a depth of 0.005 cm (0.002 inch). Figure 10 shows this blade after the stone impact test run.
2. Rivet test - Paint was removed at the impact sites. Figure 11 shows this blade after the rivet test run.
3. Steel nut test - The strike was on the sheath on the face side of the blade. The depth of the indentation in the sheath was 0.102 cm (0.040 inch). The width was 1.52 cm (0.6 inch). Figure 12A shows the blade after nut impact.
4. Bolt test - The bolt impacted directly on the leading edge. The impact produced an indentation 0.19 cm (0.060 inch) deep and 0.508 cm (0.200 inch) wide. The leading edge was also slightly bent toward the face side, approximately 0.152 cm (0.060 inch). Figure 12B shows the blade after the bolt impact.



B) FACE SIDE

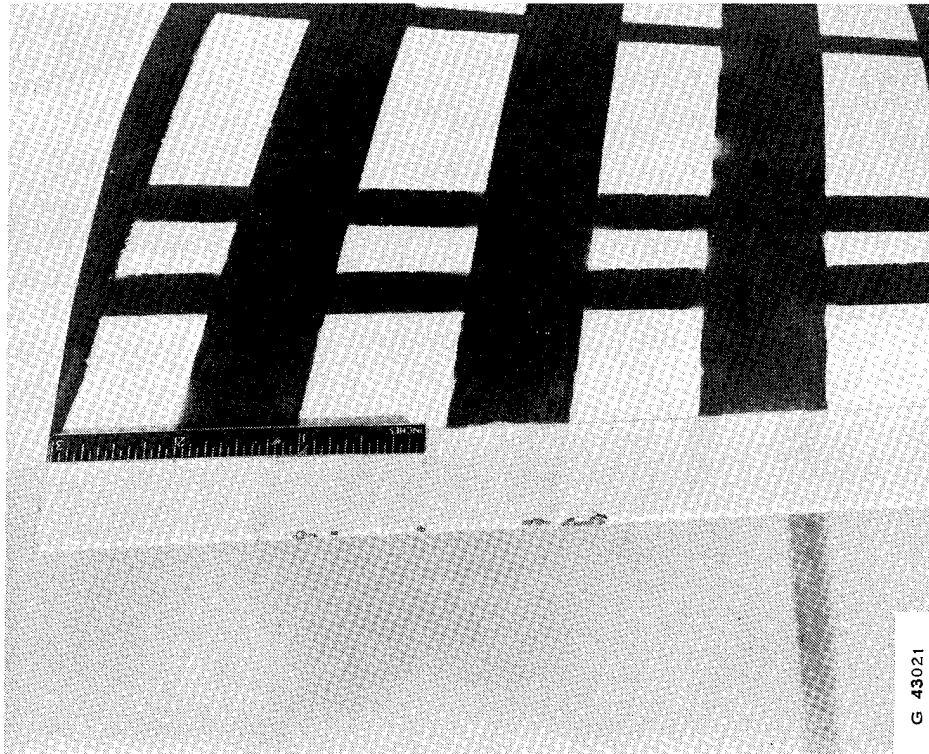

CAMBER SIDE

FIGURE 10. STONE EROSION - BLADE B-1

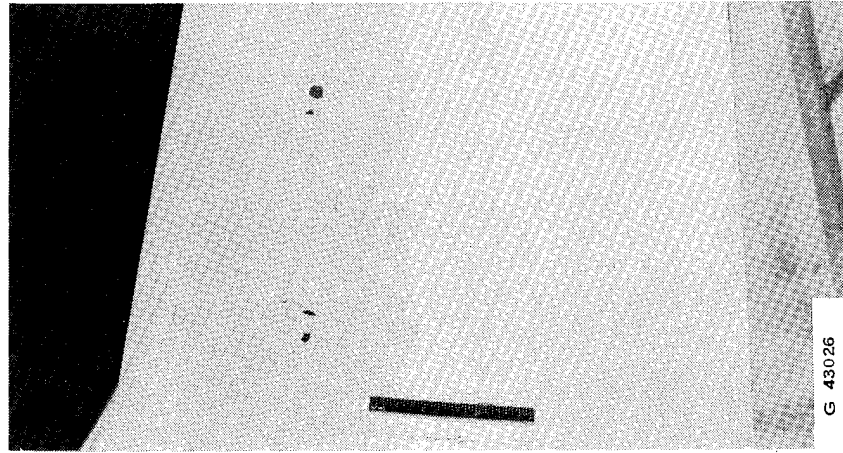

C) FACE SIDE - MID BLADE

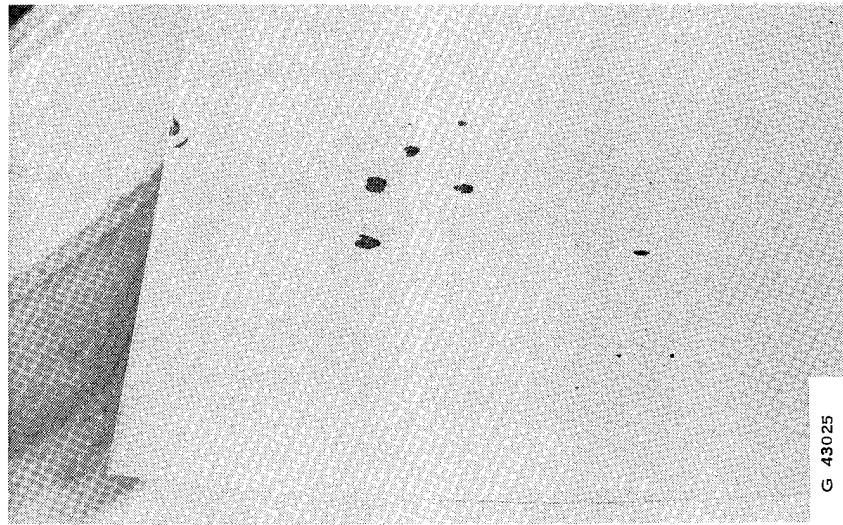

B) FACE SIDE - UPPER BLADE

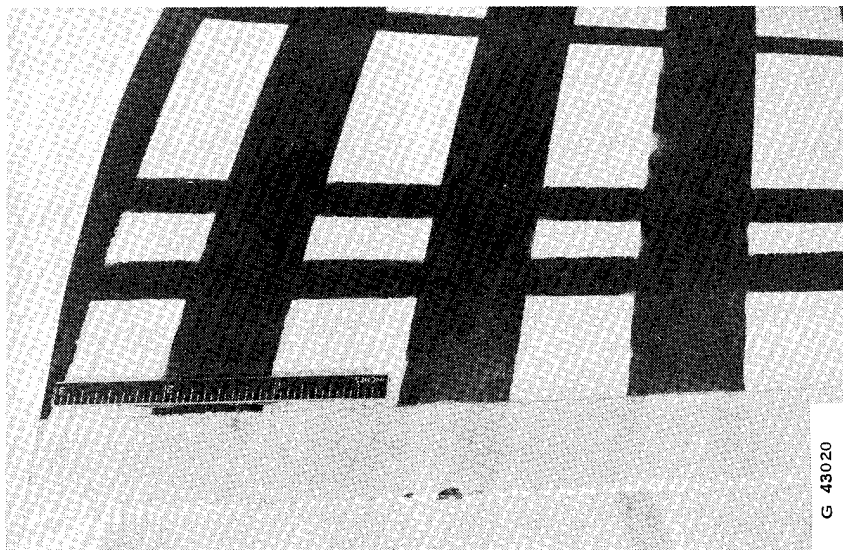

A) LEADING EDGE - CAMBER SIDE

FIGURE 11. RIVET STRIKES - BLADE B-1

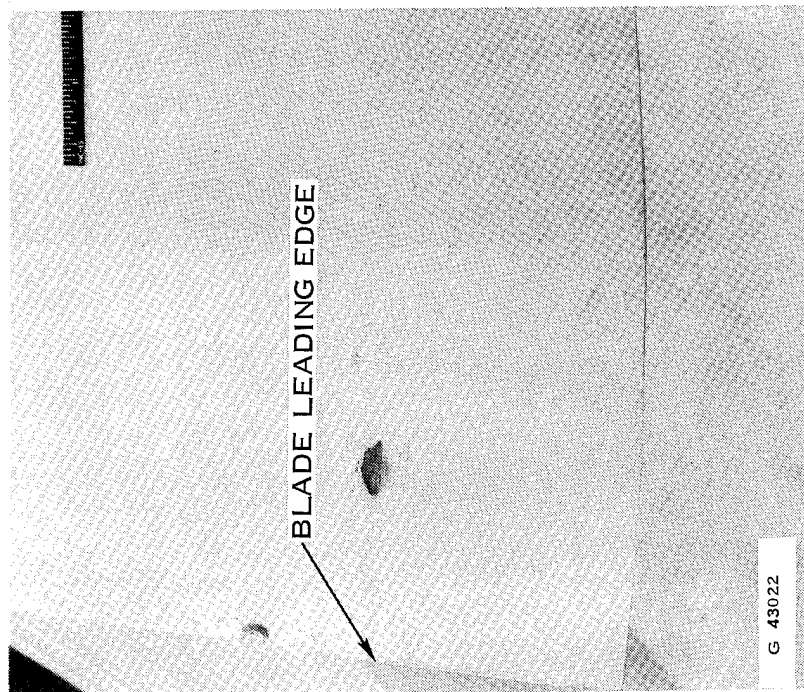

A) NUT STRIKE — FACE SIDE OF BLADE

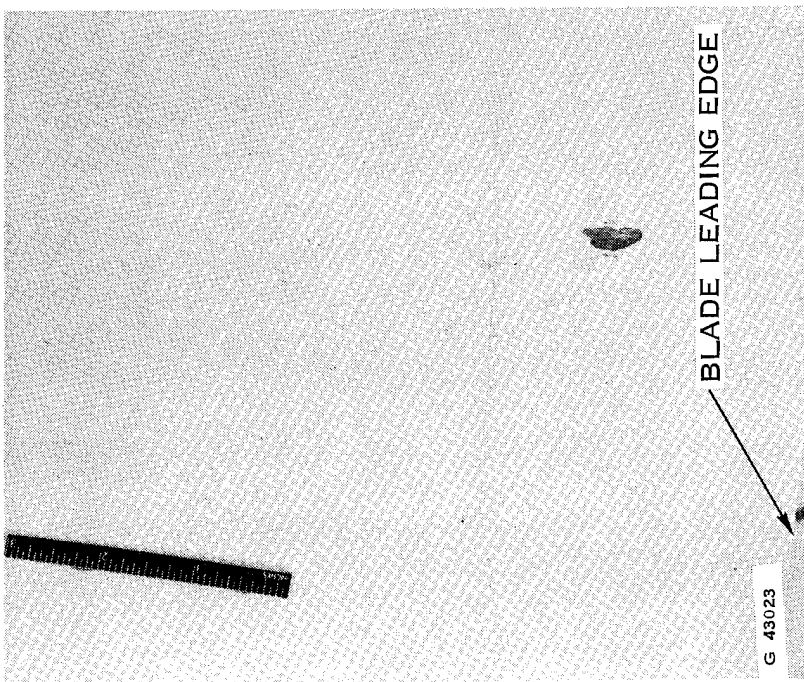

B) BOLT STRIKE — FACE SIDE OF BLADE

FIGURE 12. NUT AND BOLT STRIKES — BLADE B-1

The blade frequencies are presented in Table V. No significant change was noted on Blade B1 resulting from the tests. Figure 13 summarizes the location and effect of the impacts on the blade.

#### Blade B-2 - Iceball Impact Tests

This blade was impacted by a 5.08 cm (2.0 inch) diameter iceball in each of two tests. Specific characteristics of this media are shown in Table III. The blade struck about 25% of the first iceball and 100% of the second. There was no internal structural damage. A drop in the second flatwise static frequency of 2.8% coupled with minor change in the first flatwise mode and the first torsion mode were not considered significant since the displacement of the leading edge is expected to modify the blade resonance slightly in this direction. Frequency data is presented in Table V.

Surface indications are noted below:

1. First iceball test - The leading edge was deformed out of plane in the impact area about 0.0254 cm (0.010 inch).
2. Second iceball test - The leading edge was deformed additionally to a total of 0.102 cm (0.040 inch) out-of-plane.

Figure 14 indicates the location and effect of the iceball impacts on the blade.

#### Blade B-3 - 454 gram (1 pound) Gelatin Simulated Bird Impact

This blade was impacted by a 454 gram (1 pound) simulated gelatin bird. The slice removed by the blade as the result of the impact was 249 grams (0.55 pound). Visual examination of the blade after impact revealed sheath deformation in the impact region and shell fractures in the inboard area of the blade on both sides. Figures 15 and 16 show this damage. Tap and other visual indications are presented in Figure 17. Some reduction in frequencies were observed as the result of impact. These are shown in Table V. A drop of 5% in a frequency was considered evidence of structural damage to the blade. As indicated in the table, the first torsional frequency was especially effected, dropping 16.1%.

#### Blade B-5 - 909 gram (2 pound) Gelatin Simulated Bird Impact

This blade was impacted by a 909 gram (2 pound) simulated gelatin bird. The slice removed by the blade was 319 grams (0.7 pound). As a result of impact, the shell, sheath and foam fill separated from the blade, leaving the titanium spar. The loss represented only about 21% of the total blade weight. Figure 18 shows the remaining spar. In the spar area, the fracture mode, as shown in Figure 18 was by interlaminar shear in the composite shell, since material from the inner plies of the

TABLE V  
FOD BLADE FREQUENCIES (Hz)  
BEFORE AND AFTER TEST

<u>Blade Number</u>	<u>1F First Flatwise Mode</u>	<u>2F Second Flatwise Mode</u>	<u>1T First Torsional Mode</u>
<u>B-1 (Nut, Bolt, Rivets Gravel)</u>			
Before	107.05	257.28	370.85
After	107.24	256.83	369.99
<u>B-2 (Iceball Two 2.0 inch Dia)</u>			
Before	108.06	264.63	369.86
After	107.61	257.13	366.80
<u>B-3 (1 lb Simulated Bird - 56% Hit)</u>			
Before	107.86	263.14	372.57
After	101.45	253.74	312.03
<u>B-4 (1.1 lb Chukar Partridge - 57% Hit)</u>			
Before	107.86	263.90	369.35
After	104.07	256.28	331.73
<u>B-5 (2 lb Simulated Bird - 35% Hit)</u>			
Before	107.86	262.08	370.42
After	Not performed - shell was lost from spar		
	Spar (platform and retention intact)		

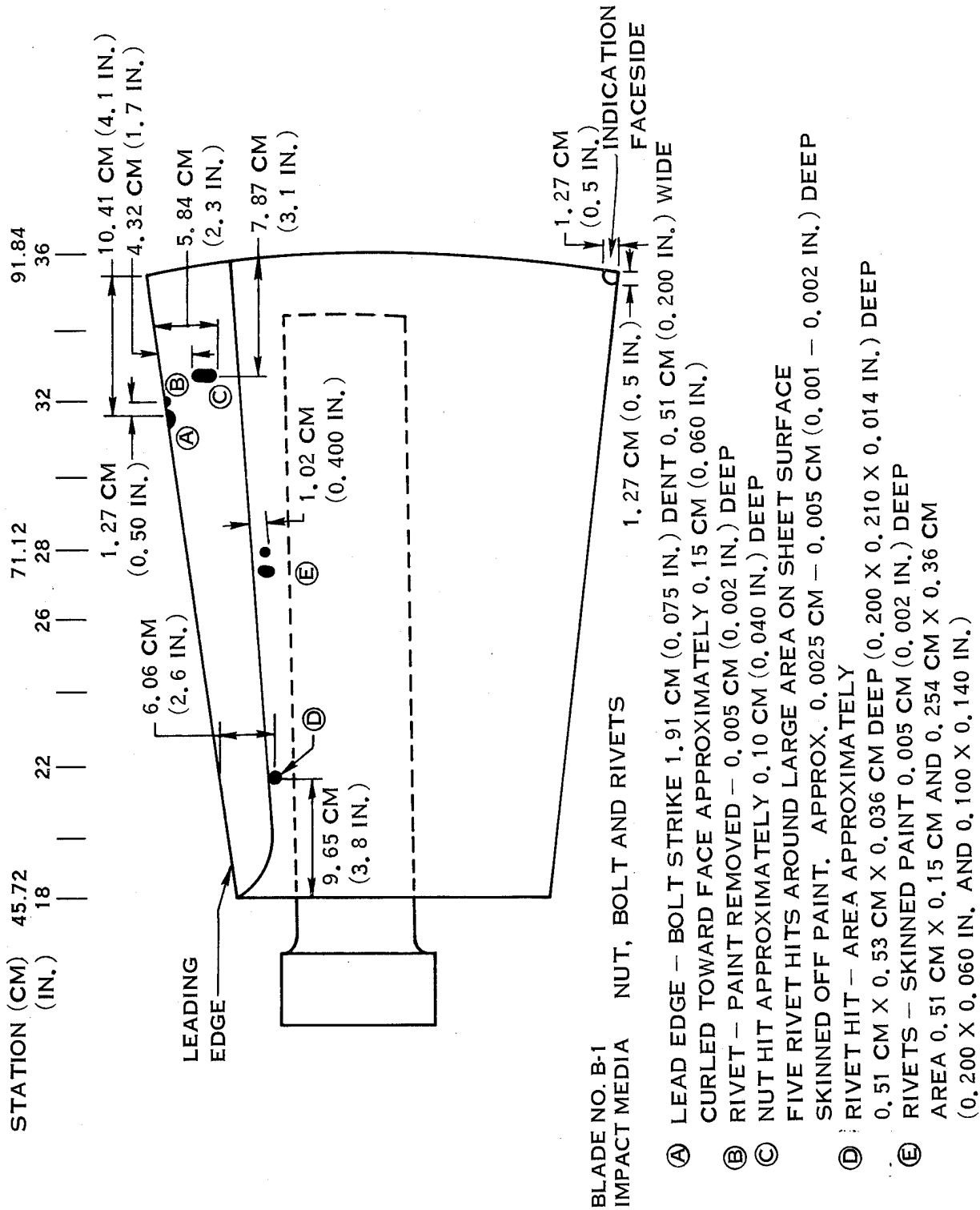
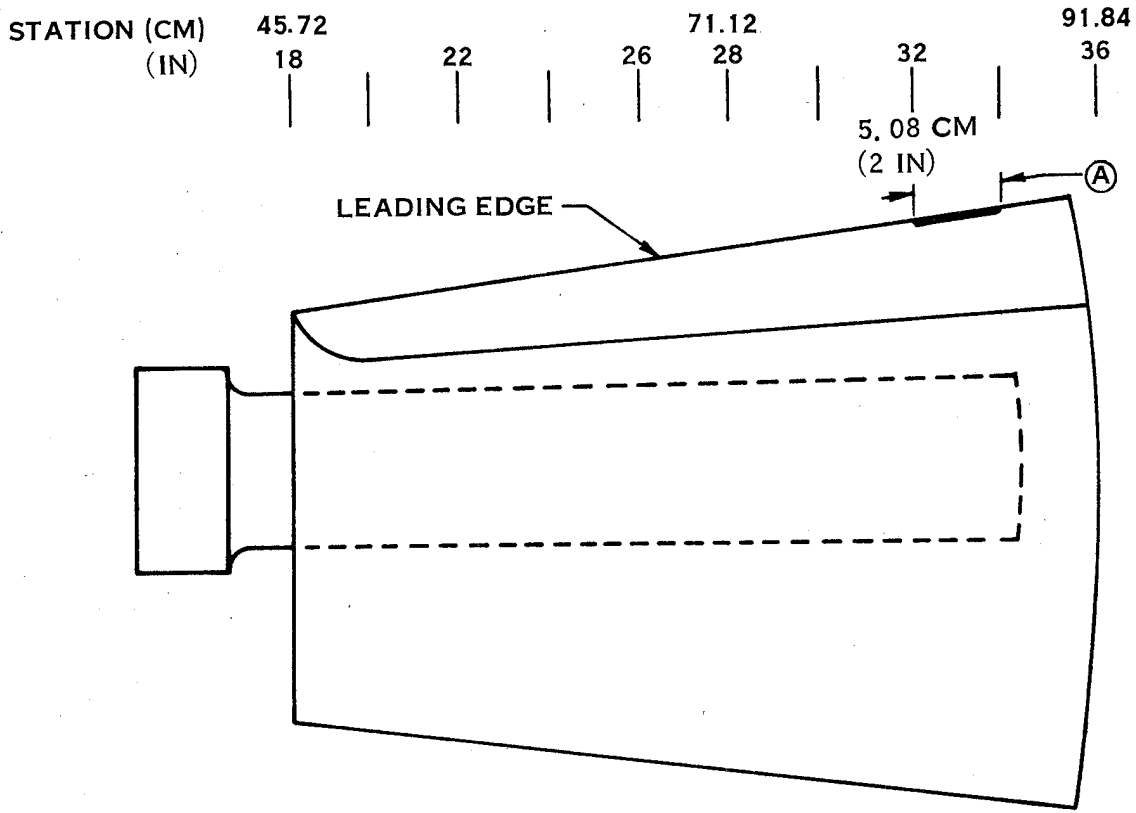

FIGURE 13. SMALL MEDIA IMPACT LOCATIONS - BLADE B-1



IMPACT MEDIA 5.08 CM (2 IN) ICE BALLS—STRUCK  
WITH 2 BALLS (APPROX. 56 GM EACH)

- (A) LEAD EDGE OVER 5.08 CM (2 IN) LENGTH BENT SLIGHTLY  
TOWARD CAMBER 0.10 CM (0.040 IN) AT MAX DEFLECTION

FIGURE 14. ICE BALL IMPACT LOCATION — BLADE B-2

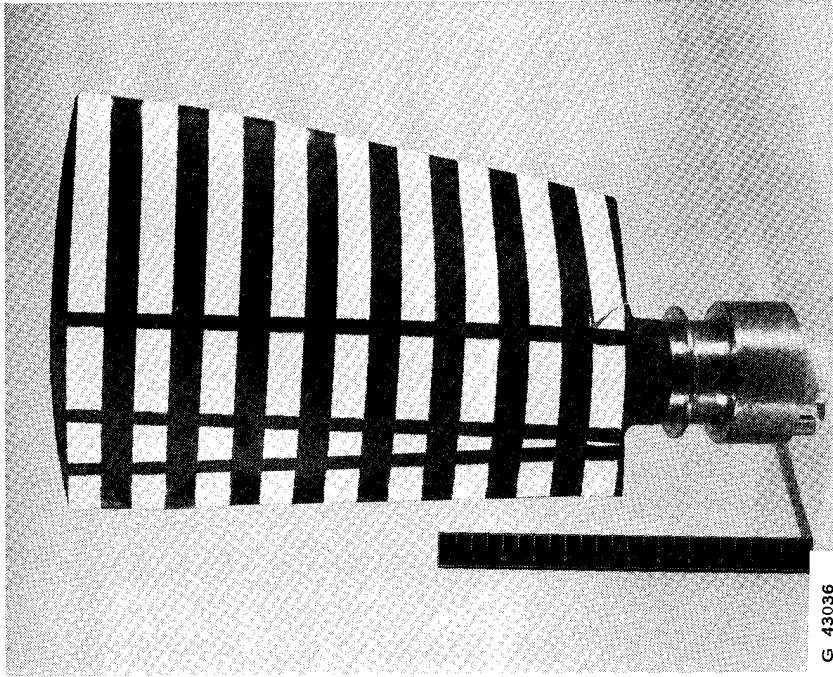

B) CAMBER SIDE

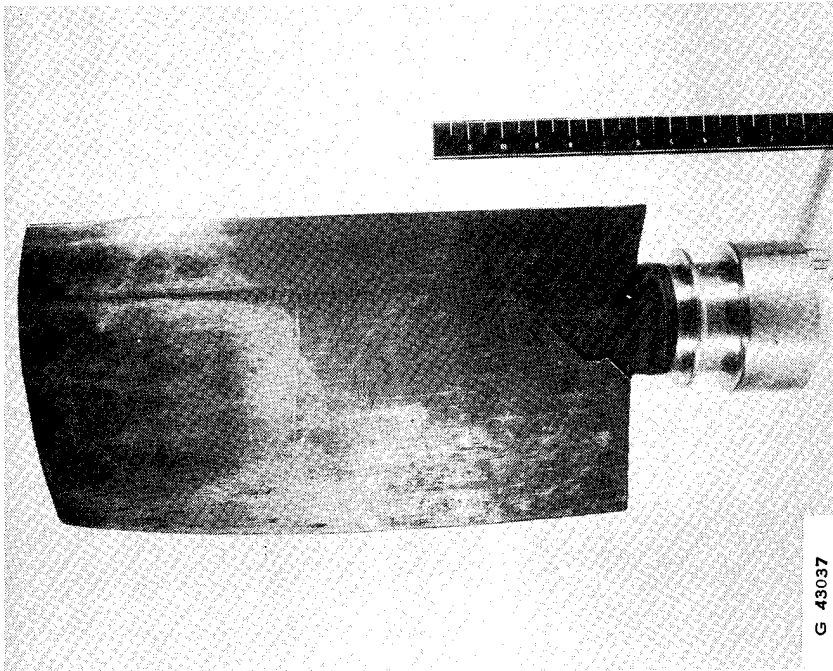

A) FACE SIDE

FIGURE 15. SIMULATED BIRD STRIKE TEST BLADE B-3 - POST TEST CONDITION  
BIRD WEIGHT 454 GM (1.0 LB); 255 GM (9 OZ) SLICE SIZE

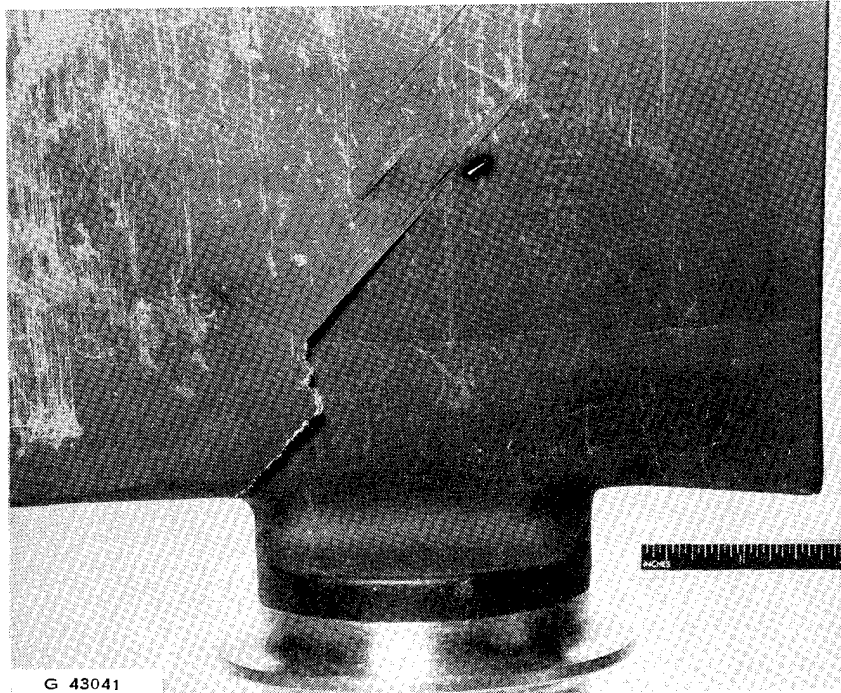

A) FACE SIDE

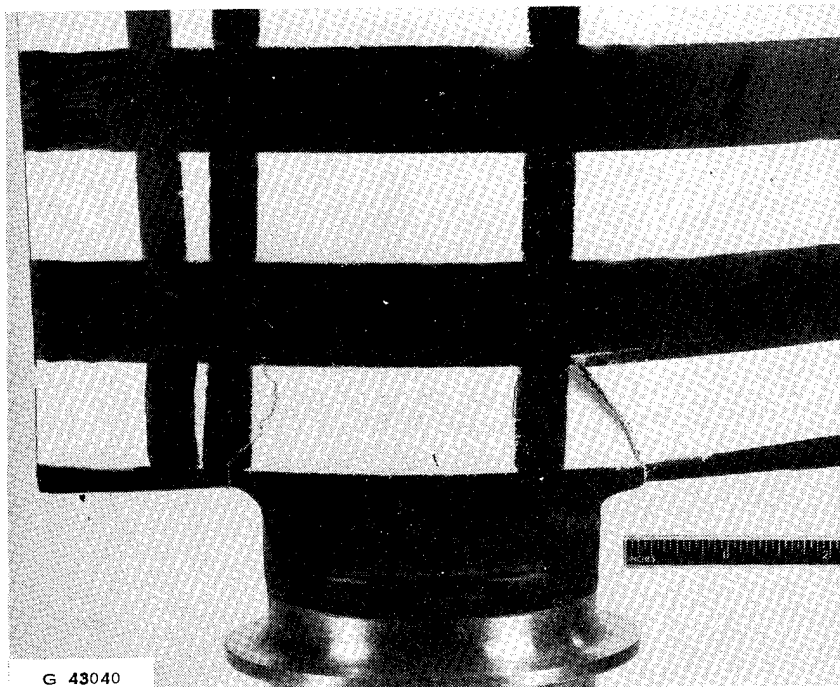

B) CAMBER SIDE

FIGURE 16. 454 GM (1.0 LB) SIMULATED BIRD TEST – BLADE B-3  
POST TEST CONDITION – IN BOARD END; 255 GM (9 OZ)  
SLICE SIZE

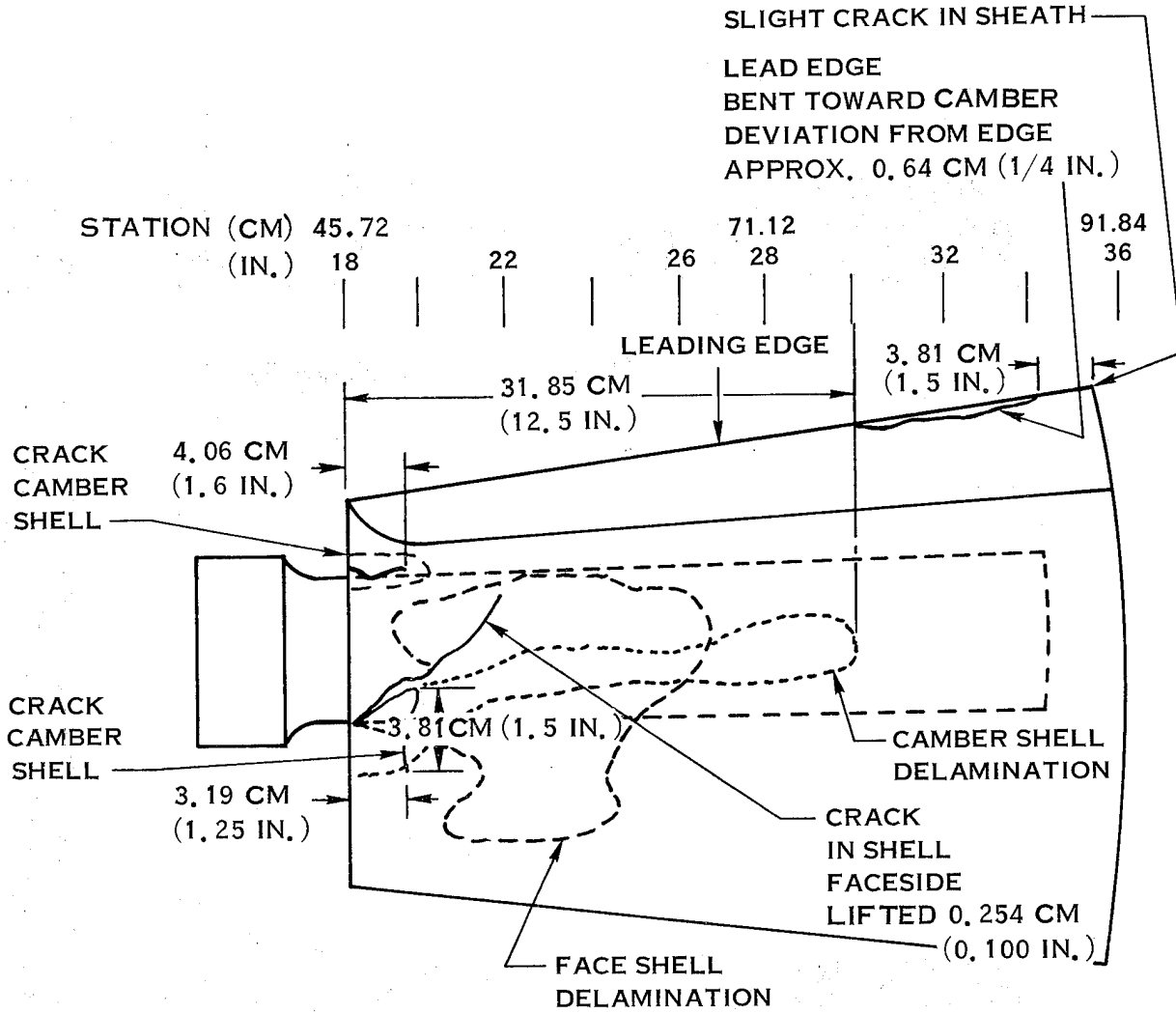

IMPACT MEDIA 454 GM (1 LB) SIMULATED BIRD - 56% HIT

FIGURE 17. POST TEST CONDITION - BLADE B-3

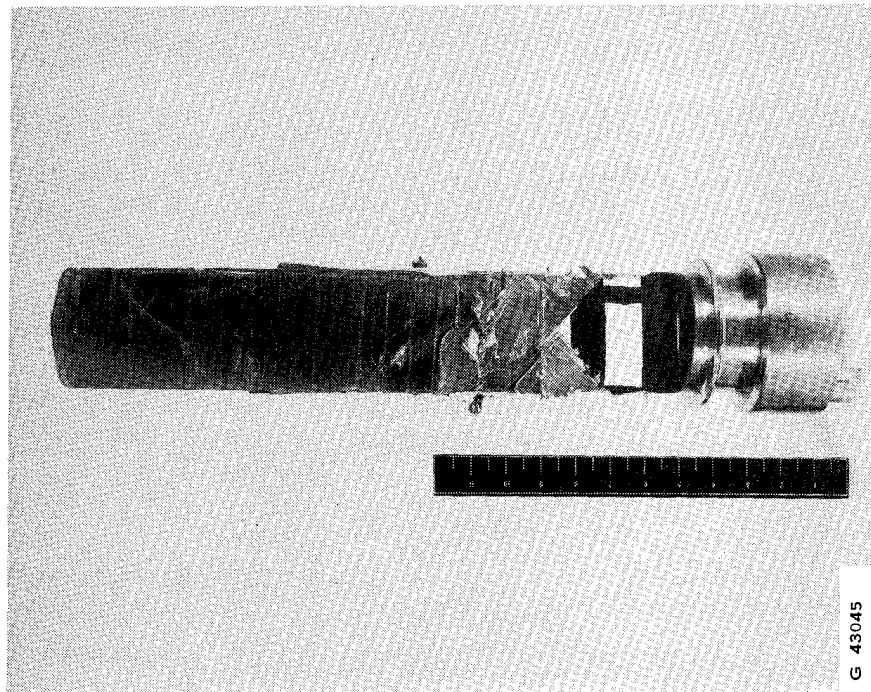

B) CAMBER SIDE

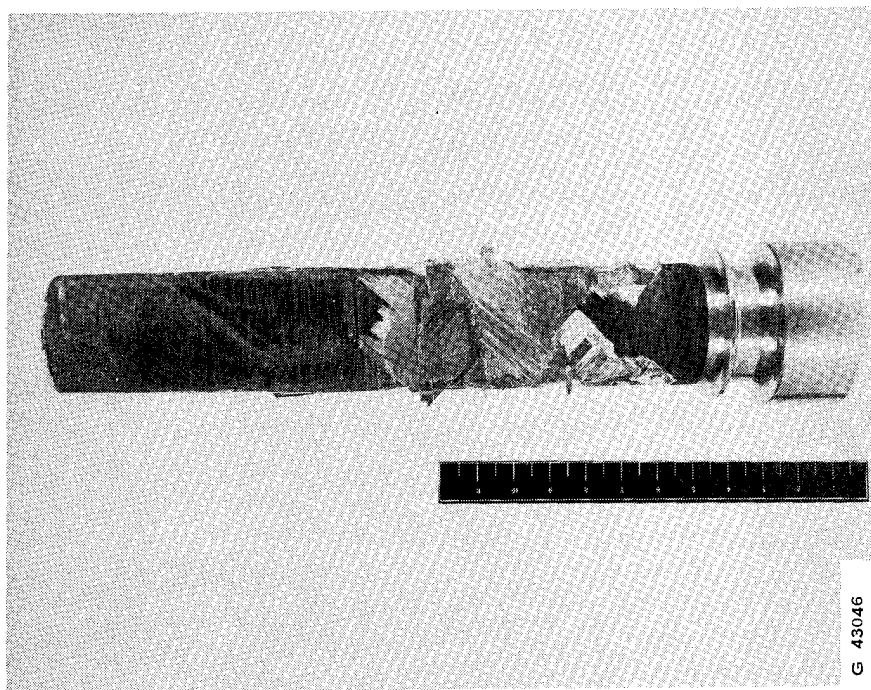

A) FACE SIDE

FIGURE 18. SIMULATED BIRD STRIKE BLADE B-5 - POST TEST CONDITION  
BIRD WEIGHT 909 GM (2 LB); 316 GM (11 OZ) SLICE SIZE

shell remained securely bonded to the spar. No failure of the structural adhesive was observed. In addition, no spar damage was detected by Zygo inspection of the spar and retention.

#### Blade B-4 - 499 gram (1.1 pound) Real Bird Impact

This blade was impacted by a 499 gram (1.1 pound) chukar partridge. The slice removed by the bird as the result of the impact was 272 grams (0.6 pound). Visual examination of the blade after impact revealed sheath deformation in the area of impact and fractures in the inboard area of the blade similar to those present on B-3. Figures 19 and 20 show these areas. Tap and visual indications are presented in Figure 21. As indicated in Table V the drop in frequency in the first torsional mode was 10% indicating blade structural damage. Eyelash airfoil plots of two stations are presented in Figure 22. They represent the airfoil at the 50.8 cm (20 inch) and 81.3 cm (32 inch) airfoil stations, the latter being the impact station.

The destructive examination of B-4 was conducted by the dye penetrant method previously described. The examination essentially confirmed the damage evidenced by the NDE. Slightly more interlaminar fracture was discovered on the camber side of the blade. This fracture extended from the spar tip to the leading edge impact area. Also, the face side exhibited shell to foam delamination aft of the spar. The increased thickness of the shell in these areas is the probable cause for the NDE insensitivity. Figure 23 outlines the areas of damage destructively determined. A section of the leading edge sheath was removed to determine the extent of impact damage to it. A photomicrograph of the sheath section is presented in Figure 24. Gross bending of the sheath is evident in the section in the blade aft of the solid portion of the leading edge. This resulted from a gap left inadvertently between the leading edge solid section (insert) and the composite shell during sheath bonding. There is also evidence of impact induced debonding in the braze joint between the leading edge insert and the face side sheath flank.

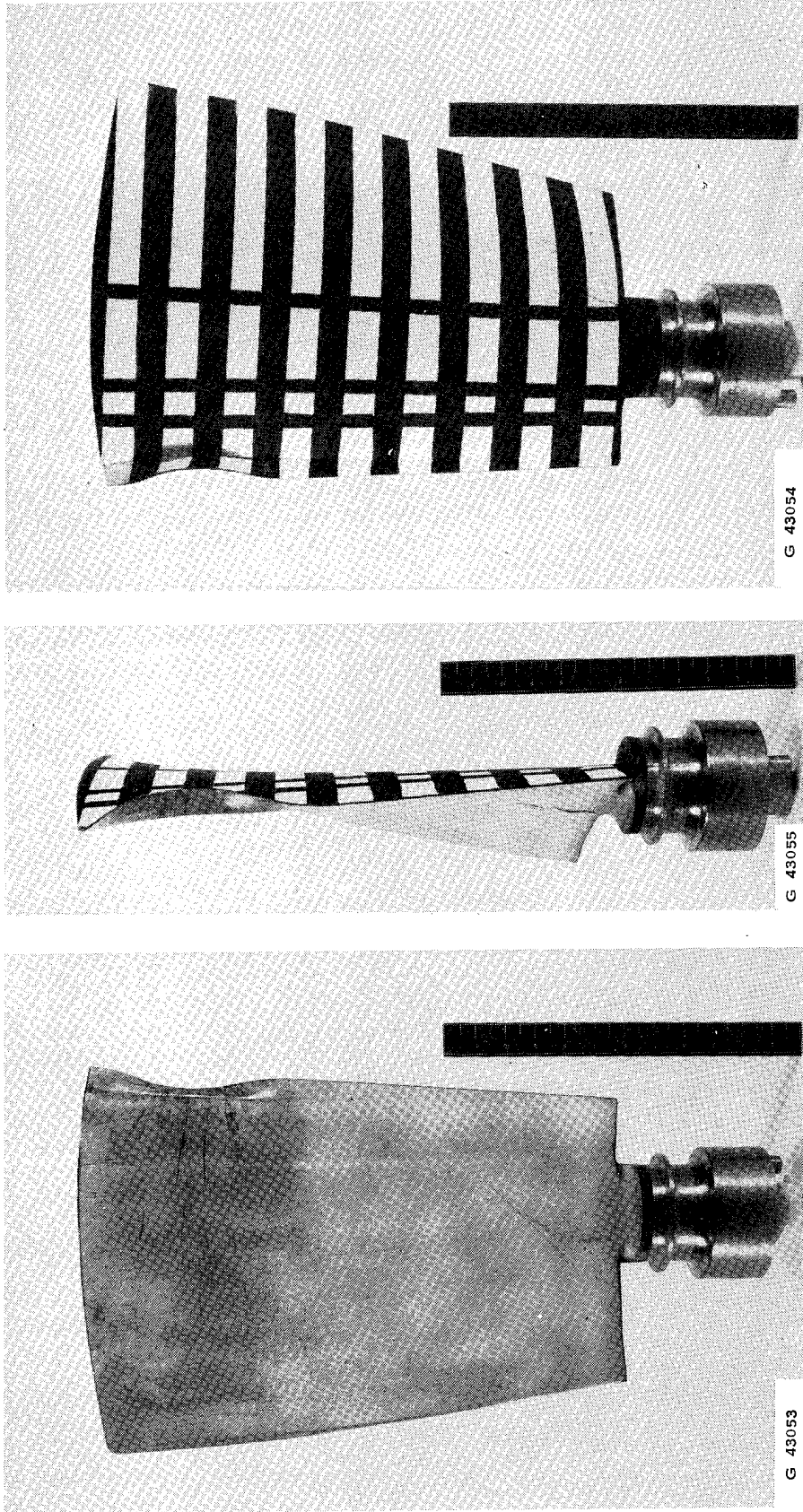

A) FACE SIDE VIEW

B) LEADING EDGE VIEW

C) CAMBER SIDE VIEW

FIGURE 19. REAL BIRD STRIKE - BLADE B-4  
POST TEST CONDITION  
BIRD WEIGHT 499 GM (1.1 LB)  
SLICE SIZE 277 GM (9.7 OZ)

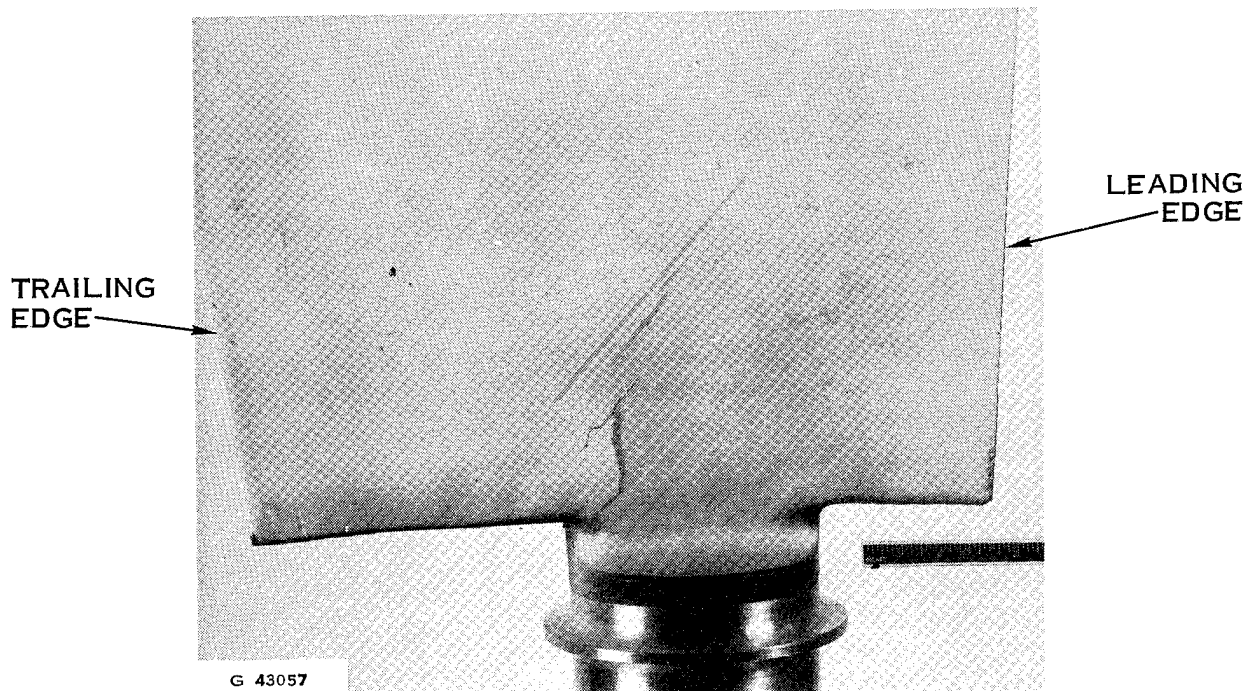

A) FACE SIDE

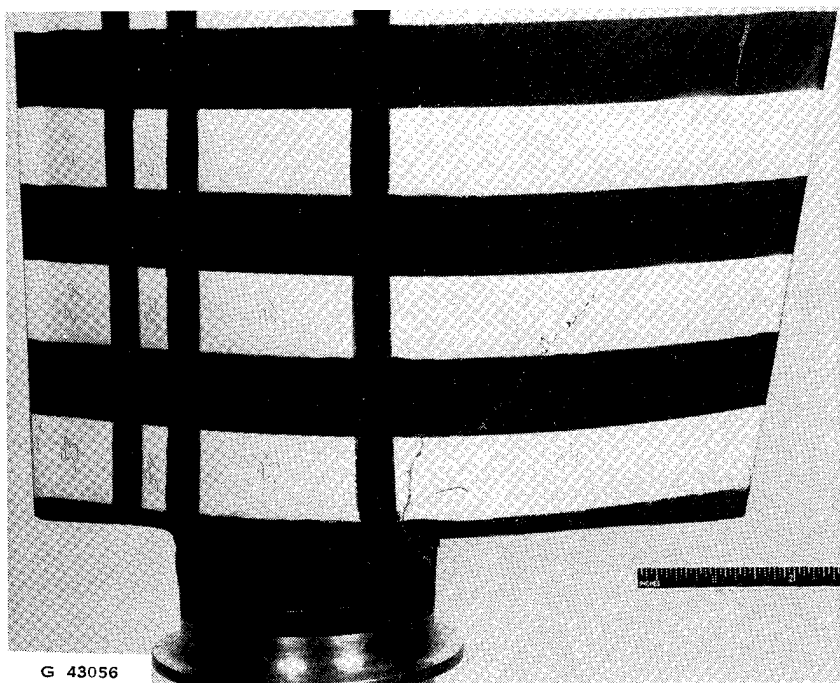

B) CAMBER SIDE

FIGURE 20. REAL BIRD STRIKE TEST BLADE B-4  
INBOARD AREA - POST TEST CONDITION  
BIRD WEIGHT 499 GM (1.1 LB)  
SLICE SIZE 277 GM (9.7 OZ)

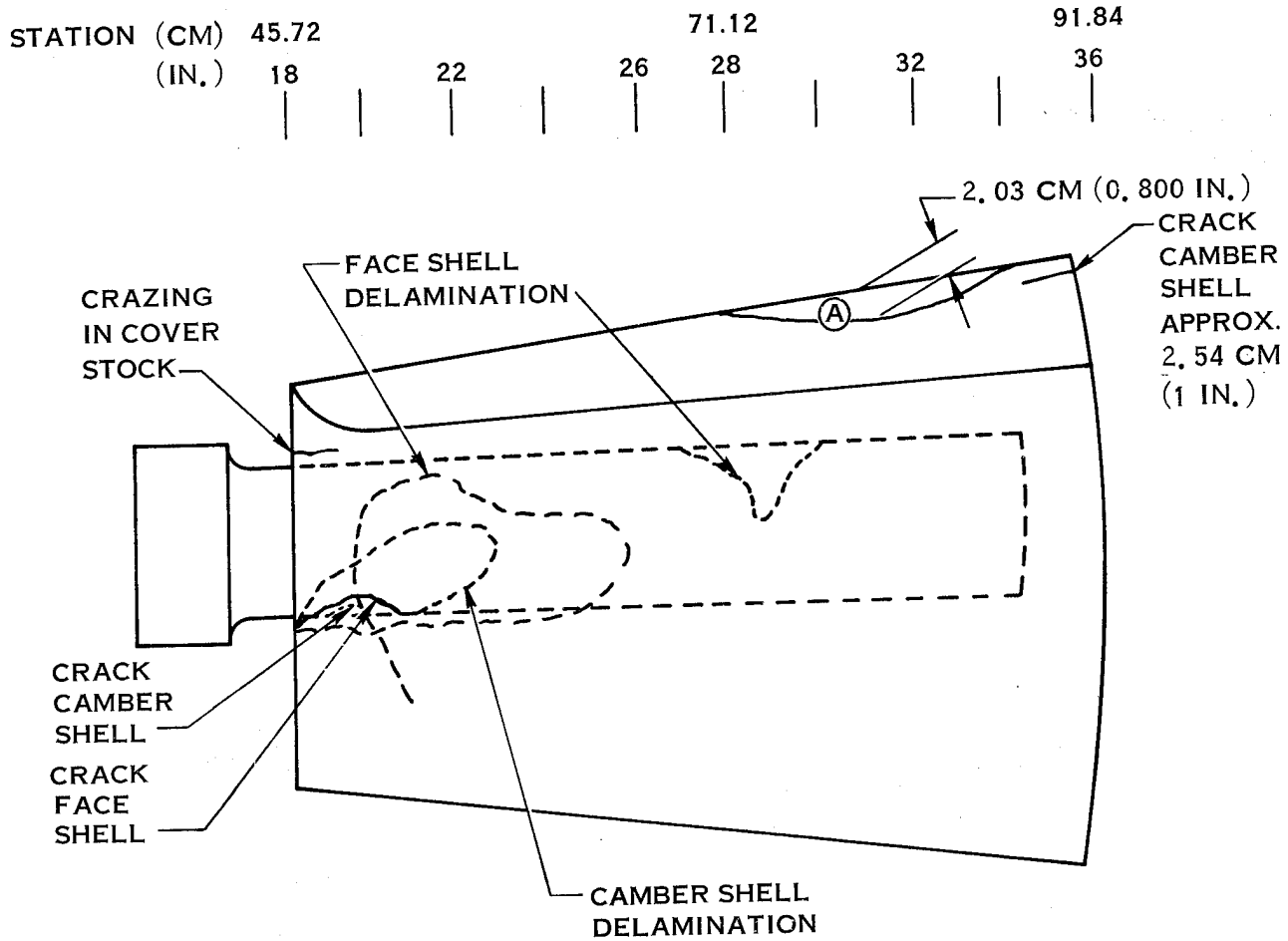

IMPACT MEDIA: CHUKAR PARTRIDGE - 499 GM (1.1 LB) 55% SLICE SIZE

Ⓐ LEAD EDGE OF SHEATH CURLED BACK 2.03 CM (0.800 IN.)  
1.57 RAD (90°) TO CHORD ON CAMBER SIDE.

FIGURE 21. POST TEST CONDITION - BLADE B-4

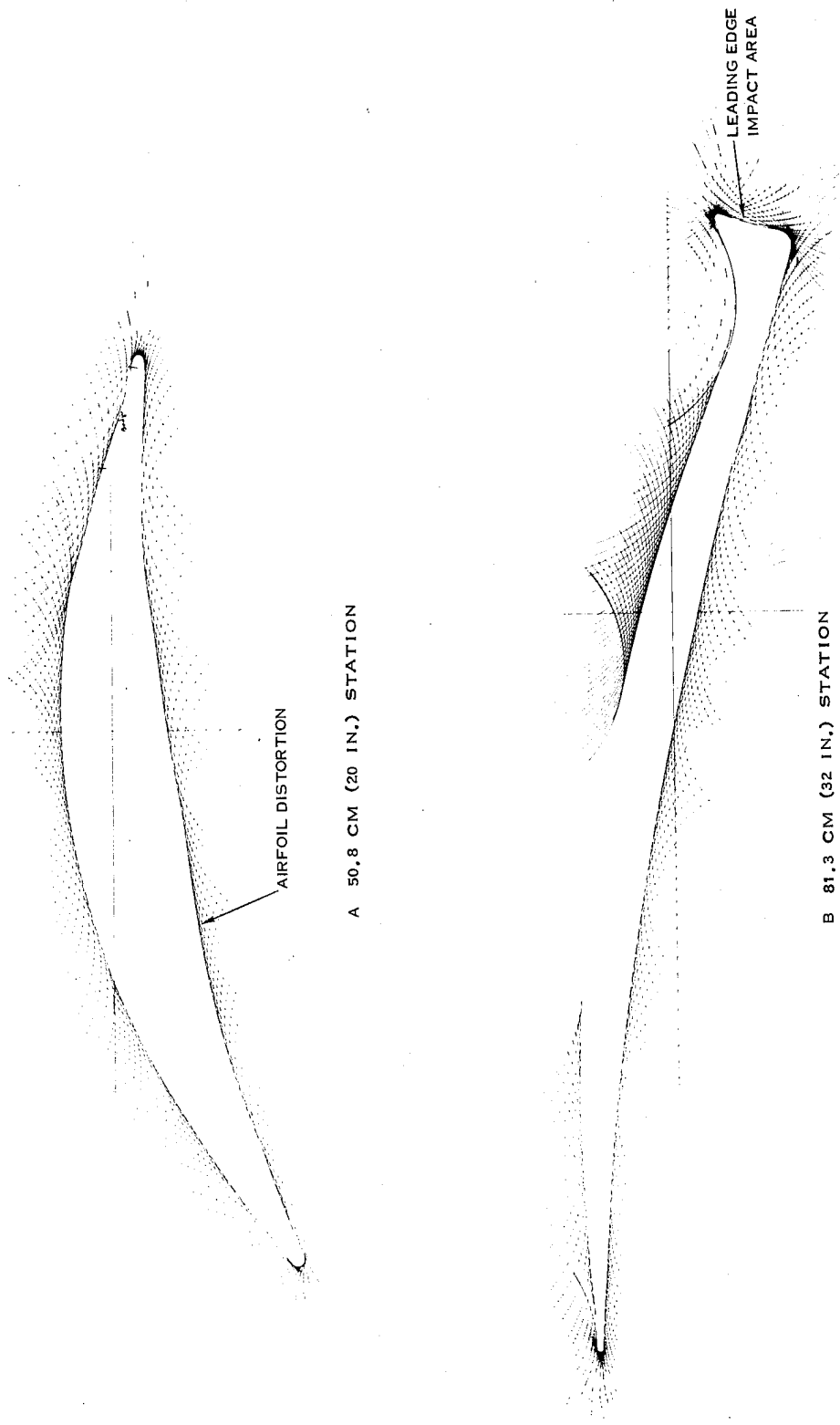

FIGURE 22. EYELASH AIRFOIL PLOTS -- BLADE B-4 POST-TEST

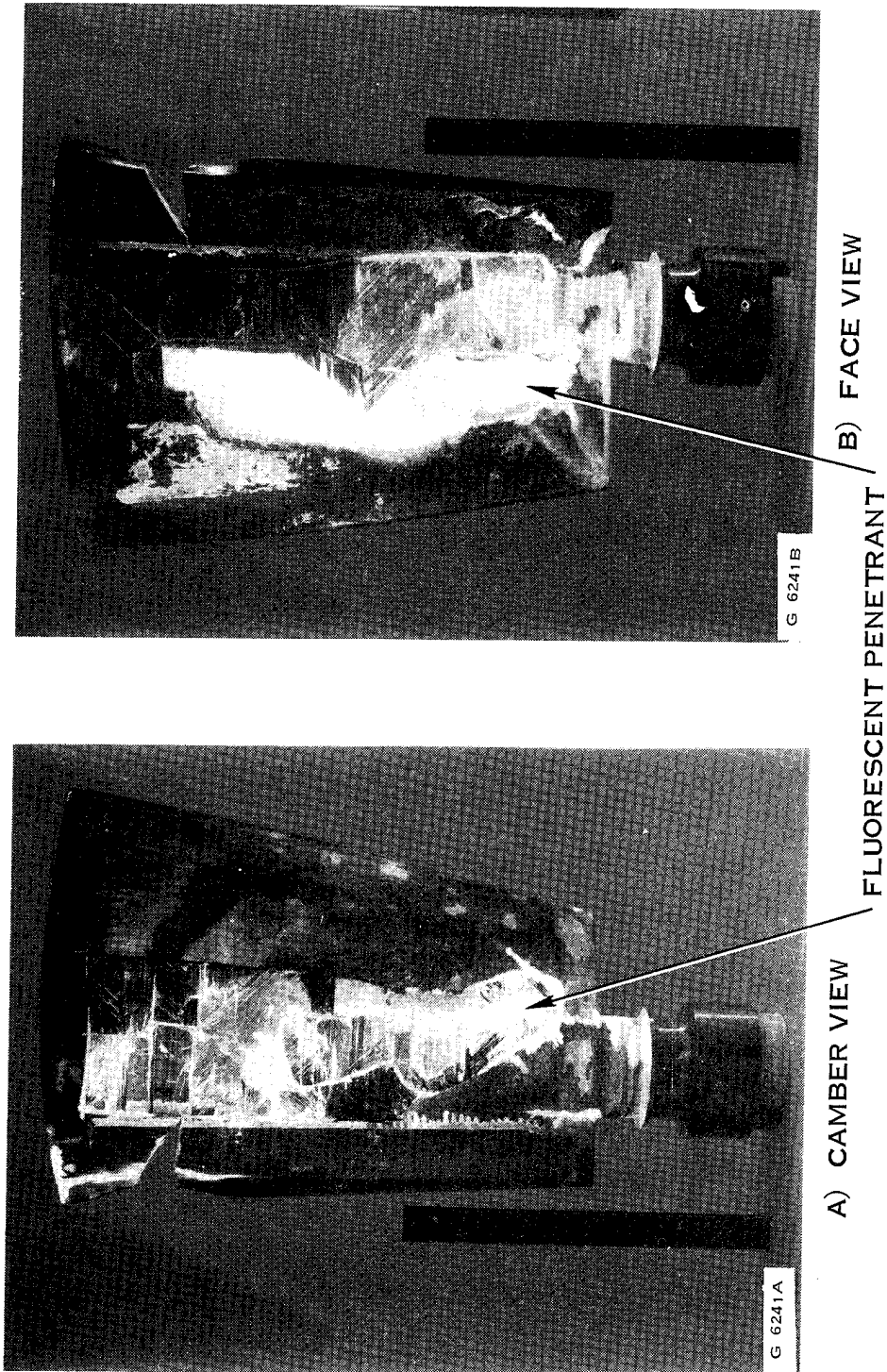
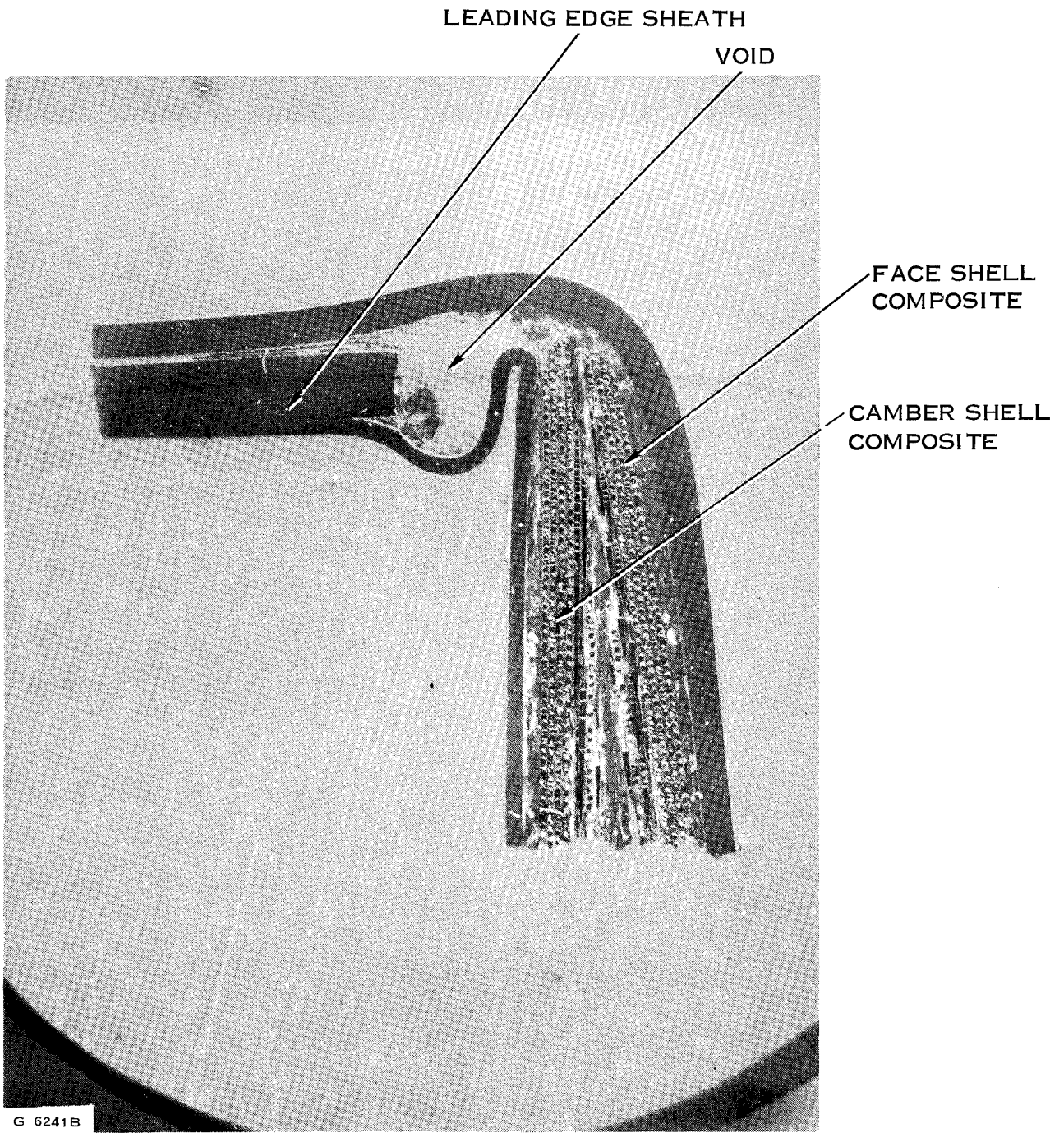

FIGURE 23. DESTRUCTIVE EXAMINATION BLADE B-4

CHORDWISE SECTION AT 81.3 CM (32.00 IN.) STATION



MAGNIFICATION 5X

FIGURE 24. PHOTO MICROGRAPH - LEAD EDGE OF BLADE B-4

### CONCLUSIONS

The following conclusions are made based on the results of the FOD tests conducted in this program:

1. The Titanium spar and Boron-Epoxy shell composite Q-Fan blade design tested herein:
  - (a) Has demonstrated satisfactory resistance to damage by small objects (gravel, bolts, nut, rivets and two inch iceballs).
  - (b) Has demonstrated the ability to impact birds about one pound in weight with 9 to 10 ounce slice size without loss of blade components but with significant damage to the blade; a two pound bird (11 oz slice size) caused loss of the blade shell from the spar.
2. Evaluation of damaged blades indicated interlaminar shear and peel within the shell plies to be the primary mode of fracture; therefore:
  - (a) Improvement in matrix interlaminar properties (e.g., incorporation of metal matrix composite) should improve the ability of the blade to withstand large bird impact.
  - (b) Design changes to the blade to decrease the torsional moment applied to the blade shell during impact (e.g., increase the chord width of the spar) should improve the ability of the blade to withstand large bird impact.

APPENDIX A

CONVERSION OF U. S. CUSTOMARY UNITS TO SI UNITS

The International System of Units (SI) was adapted by the Eleventh General Conference on Weights and Measures, Paris, October 1960. Conversion factors for the units used herein are given in the following table.

Physical Quantity	U. S. Customary Unit	Conversion Factor (*)	SI Unit
Length	in.	0.0254	meters (m)
Temperature	(F° + 460)	5/9	degrees Kelvin (°K)
Density	lbm/in <sup>3</sup>	27.68 X 10 <sup>3</sup>	kilograms per cubic meter (Kg/M <sup>3</sup> )
Load	lbf	4.448	newtons (n)
Modulus, stress	psi = lbf/in <sup>2</sup>	.6895	newtons per square meter (N/M <sup>2</sup> )
Plane angle	degree °	0.01745	radians (rad)
Mass	lbm	0.4536	grams (gm)
Velocity	fps	0.3048	meter/second (m/s)
Speed	rpm	0.1047	radian/second (rad/s)
Viscosity	cps	0.001	newton second/meter <sup>2</sup> (Ns/m <sup>2</sup> )

\*Multiply value given in U.S. Customary Units by conversion factor to obtain equivalent value in SI Unit.

Prefix	Multiple
centi (c)	10 <sup>-2</sup>
Kilo (K)	10 <sup>3</sup>
Mega (M)	10 <sup>6</sup>

## APPENDIX B

### PROCEDURE FOR MAKING ICEBALLS - 5.08 CM DIA.

Iceball Material: Supersaturated Carbonic Acid

Specific Gravity of Iceball: 0.80 - 0.85

#### PROCESS

1. Fill the mold cavities with supersaturated carbonic acid until the fluid overflows.
2. Place the molds in a freezer and freeze at approximately 244°K (-20°F) for a minimum of three hours.
3. Remove from the freezer and allow it to remain at room temperature 292 - 300°K (65 to 80°F) for five to ten minutes.
4. Remove and shape the overflow knob by rubbing the area against a smooth metal surface which is at room temperature.
5. Five to ten minutes after removing the setup from the freezer remove the balls from the mold. Caution: Handle the iceballs carefully and quickly to prevent breaking and melting.

After removal from the mold the iceballs should be maintained in the freezer.

#### ICEBALL CHECKS.

1. In checking specific gravity, weigh iceball on gram scale. Weight should be 54-59 grams for a specific gravity of 0.80 to 0.85 for 5.08 cm (2 inch) diameter.

#### TRANSPORTING AND INSTALLING IN RIG

1. Transport iceballs to rig in an insulated container. Exposure of iceballs in insulated container outside of freezer should not exceed 45 minutes.
2. Iceball handling time between freezer and insulated container, and between insulated container and storage compartment of rig should be kept to a minimum.
3. Storage compartment of rig is to be below freezing before inserting iceball.

**Hamilton Standard**  
WINDSOR LOCKS, CONNECTICUT 06096

DIVISION OF UNITED AIRCRAFT CORPORATION

U  
A

**DATA TRANSMITTAL**

**Date:** 25 Jan. 1974

**To:** NASA - Lewis Research Center  
21000 Brookpark Road  
Cleveland, Ohio 44135

Attn: R.H. Johns, Mail Stop 49-3

**Contract/Item:** NAS3-16778  
Final Report HSER 6241  
NASA CR No. 134521

**Number of Copies:** 18 printed copies plus 2 unbound copies and artwork

**Comments:**

The other printed copies are being distributed to the addressees on the "Final Report Distribution List" provided to the Contractor.

*Sherwood V. Martin*

**Sherwood V. Martin  
Contract Administrator**

**cc:** ✓

**Ecc:**