

NASA TECHNICAL NOTE

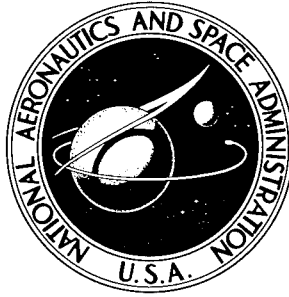

NASA TN D-3549

NASA TN D-3549

DISTRIBUTION STATEMENT K
Approved for public release
Distribution Unlimited

19960416 061

VIBRATIONAL CHARACTERISTICS OF SANDWICH PANELS IN A REDUCED-PRESSURE ENVIRONMENT

by Clemans A. Powell, Jr., and David G. Stephens

*Langley Research Center
Langley Station, Hampton, Va.*

NATIONAL AERONAUTICS AND SPACE ADMINISTRATION • WASHINGTON, D. C. • AUGUST 1966

DEPARTMENT OF DEFENSE
PLASTICS TECHNICAL EVALUATION CENTER
PICATINNY ARSENAL, DOVER, DELAWARE
QUALITY INSPECTED 1

9676
9/95
PLASTICS

NASA TN D-3549

VIBRATIONAL CHARACTERISTICS OF SANDWICH PANELS
IN A REDUCED-PRESSURE ENVIRONMENT

By Clemans A. Powell, Jr., and David G. Stephens

Langley Research Center
Langley Station, Hampton, Va.

NATIONAL AERONAUTICS AND SPACE ADMINISTRATION

~~For sale by the Clearinghouse for Federal Scientific and Technical Information
Springfield, Virginia 22151 - Price \$1.00~~

VIBRATIONAL CHARACTERISTICS OF SANDWICH PANELS IN A REDUCED-PRESSURE ENVIRONMENT

By Clemans A. Powell, Jr., and David G. Stephens
Langley Research Center

SUMMARY

An investigation was conducted to determine the vibrational characteristics of sandwich panels over a wide range of environmental pressure or density. Natural frequencies and damping of panels having aluminum honeycomb and polyurethane foam cores were determined for several modes of vibration over a pressure range from 760 torr (1 atmosphere) to 10^{-6} torr. Results indicate that no significant changes in either natural frequency or damping occur between a pressure of 1 torr and 10^{-6} torr. A decrease in pressure from 1 atmosphere to 1 torr produces an increase in frequency from 2 to 10 percent due to "apparent mass" effects and possible increases in panel thickness and shear rigidity. Furthermore, a corresponding decrease in pressure results in a linear decrease in damping due to a reduction in acoustic radiation. The change in frequency and damping with pressure is dependent upon the mode shape of the panel.

INTRODUCTION

Sandwich or composite materials are being used extensively in the design and construction of spacecraft. In such applications, these materials are exposed to a wide variation in environmental pressure or density which may affect their vibrational response characteristics. It is therefore essential to have an understanding of the vibrational characteristics of sandwich materials over the actual operating pressure range. In particular, an understanding of the changes in frequency and damping associated with changes in pressure is important in order to evaluate the vibration response of spacecraft. The vibration tests of a spacecraft, for example, are often conducted under atmospheric-pressure conditions rather than in a reduced-pressure environment for reasons of convenience. Thus, the influence of the pressure environment on the data must be considered in interpreting or extrapolating the results.

A number of frequency and damping phenomena are strongly dependent on the magnitude of the pressure environment. Natural frequency, for example, is affected by an added or "apparent mass" resulting from external pressure loading as discussed in references 1 and 2 for rigid body oscillations. Frequency of a cellular sandwich panel may also be

affected by a change in thickness or in structural rigidity caused by an internal pressure change. With respect to damping, pressure may affect the dissipation of energy internally, externally, and in joints. The magnitude of the damping resulting from air contained within the panel is uncertain; however, the dissipation of energy in structural joints is discussed in reference 3 where "air pumping" was found to be an important damping mechanism. The external damping may result from vortex formation and shedding, as discussed in reference 4, and/or from acoustic radiation (refs. 5 and 6).

Very little information is available in the literature on the vibration response of sandwich structures under reduced pressure conditions. Undoubtedly, studies have been limited because of difficulties encountered in testing such structures. Sandwich panels, for example, pose unique problems in vibration excitation or loading, panel support, and measurement techniques that are suitable for vacuum-chamber application. A distributed input loading, rather than a point loading, is required because of the low local strength of the panels. The usual acoustic methods of excitation cannot be used in vacuum-chamber applications. Furthermore, a support system which provides free edge conditions is desirable to avoid the possible large extraneous damping inherent with restrained boundary conditions.

To gain basic insight into the vibrational behavior of sandwich materials and into the effect of pressure on this behavior, a study was conducted to determine the vibrational characteristics of aluminum honeycomb and polyurethane foam core sandwich panels in a pressure range from 760 torr (1 atmosphere) to 10^{-6} torr. (1 torr = 133.3 N/m^2 .) A support and excitation system was developed which, under any pressure condition, provides a panel with a distributive vibratory loading and essentially free edge conditions. The results of this study are presented herein.

SYMBOLS

The units used for the physical quantities defined in this paper are given both in U.S. Customary Units and in the International System of Units (SI). (See ref. 7.) The following table presents factors relating these two systems of units:

U.S. Customary Unit	Conversion factor (*)	SI Unit	Abbreviation
in.	0.0254	meter	m
lbf	4.448	newton	N
lbm	0.4536	kilogram	kg
torr	133.3	newton/meter ²	N/m ²

*Multiply value in U.S. Unit by conversion factor to obtain equivalent value in SI Unit.

a	acceleration amplitude, inches/second ² (meters/second ²)
c	speed of sound in air, inches/second (meters/second)
D	flexural rigidity, pound-inches (newton-meters)
E	modulus of elasticity, pounds/inch ² (newtons/meter ²)
f	frequency of vibration, cycles/second
h	total thickness, inches (meters)
l	distance between grid lines in finite-difference net, inches (meters)
m	mass per unit area, pound-seconds ² /inch ³ (kilograms/meter ²)
N	number of cycles occurring over the range (a ₀ , a _n)
S	panel or plate surface area, inches ² (meters ²)
x	displacement amplitude, inches (meters)
δ	logarithmic decrement of damping
λ	eigenvalue
μ	Poisson's ratio
ρ	density of air, pound-seconds ² /inch ⁴ (kilograms/meter ³)

Subscripts:

c	core
f	facing
n	nth cycle of vibration

- o initial cycle of vibration
- p pressure

APPARATUS

Sandwich Panels

The panels used in this investigation were 36 inches (0.9144 m) square and had a nominal thickness of 1 inch (0.0254 m). Specific dimensions, physical properties, and identifying designations are given in table I. Note that the numbers in the panel designations indicate the densities of the materials in lbm/ft^3 and the letters indicate the materials, H for honeycomb and F for foam. The facings of each panel were constructed of 0.016-inch (4.06×10^{-4} m) 2024-T6 aluminum alloy. Two types of core material, aluminum honeycomb and plastic foam, were selected because of their frequent use in spacecraft design. The cores of the honeycomb panels 5.2H and 3.6H had vented hexagonal cells 1/4 inch (6.35×10^{-3} m) and 3/8 inch (9.52×10^{-3} m) across the flats, respectively, with a wall thickness of 0.003 inch (7.62×10^{-5} m). The foam core panels, designated as 10.1F and 2.1F, were constructed of closed cell, rigid, CO₂-blown, polyester base, polyurethane foams. The cores were foamed in place and were self-bonded to the aluminum facings.

TABLE I.- PANEL AND CORE DIMENSIONS AND PROPERTIES

Specimen	Core					Panel			
	Material	Density		Thickness		Thickness		Mass	
		lbm/ft^3	kg/m^3	in.	m	in.	m	$\text{lb-sec}^2/\text{in.}$	kg
5.2H	Honeycomb	5.2	83	1.005	0.02553	1.037	0.02634	0.0225	3.90
3.6H	Honeycomb	3.6	58	.990	.02515	1.022	.02596	.0196	3.43
10.1F	Rigid foam	10.1	162	.970	.02464	1.002	.02545	.0350	6.13
2.1F	Rigid foam	2.1	34	1.025	.02604	1.057	.02685	.0145	2.54

Environmental Chamber

The panels were tested in a combined pressure, temperature, and vibration environmental chamber which is shown schematically in figure 1. It is essentially a double-walled cylinder 6 feet (1.83 m) in internal diameter and 8 feet (2.44 m) long with an ultimate vacuum capability of 1×10^{-8} torr (altitude of approximately 500 km). The pumping system consists of two parallel 32-inch-diameter (0.81 m) diffusion pumps for the evacuation of the

inner chamber and two parallel 10-inch-diameter (0.25 m) diffusion pumps for evacuating the outer or guard chamber. Both sets of diffusion pumps are boosted by an additional 10-inch (0.25 m) pump which is in turn backed by an 80-ft³/min (3.77×10^{-2} m³/sec) mechanical pump. The wall of the inner chamber is fitted with bake-out heater elements and a liquid nitrogen cryogenic liner which provide temperatures from 400° F (478° K) to -320° F (78° K). However, during testing the temperature environment facilities were not used and all tests were conducted at room temperature. A 2000-lbf (8896 N) electrodynamic shaker is rigidly anchored external to the chamber. The armature is subjected to the guard vacuum environment and the head of the armature protrudes through the inner wall and is sealed from the guard vacuum annulus by a thin rubber diaphragm. Because of the extremely low pressure differential between the inner chamber and guard vacuum annulus, the resistance of the diaphragm to deflection is virtually independent of the pressure level.

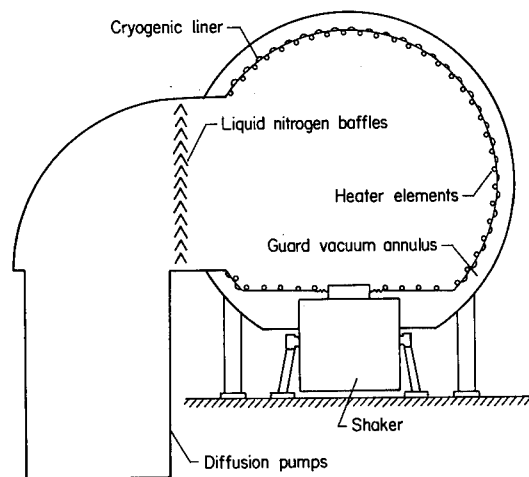

Figure 1.- Section view of the environmental chamber.

Support and Excitation System

A photograph of the panel support and excitation system is shown in figure 2. The system supported a panel in a free-edge condition and provided a distributive vibratory loading. The panels were bonded to and supported by an array of soft helical springs which were in turn bonded to a 21-inch (0.533 m) square 1.5-inch-thick (0.0381 m) aluminum plate mounted on an extension of the shaker armature. The spring constant of the springs, 7.08 lbf/inch (1240 N/m), was selected to provide relatively low rigid-body frequencies

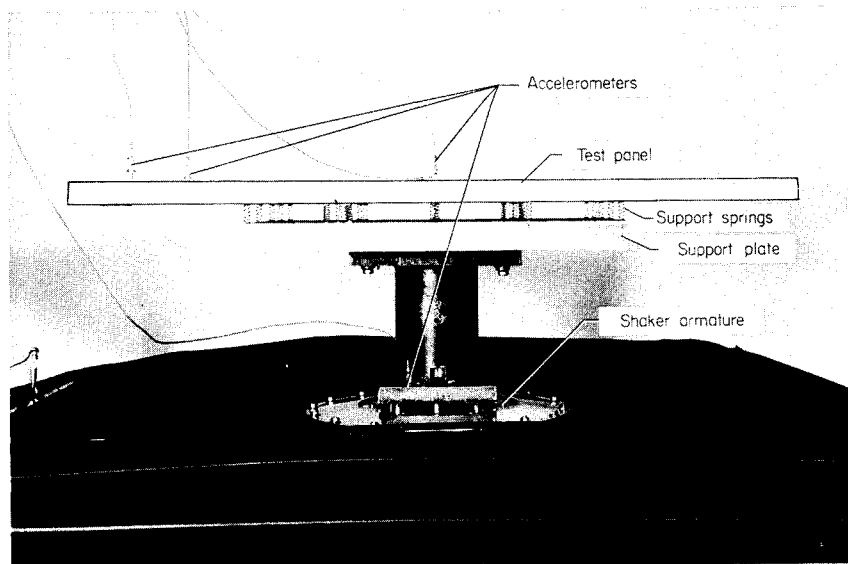

Figure 2.- Panel support and excitation system.

L-2575-3

and the spring locations were selected to provide off-nodal excitation for the first three modes.

Instrumentation

Lightweight, piezoelectric crystal accelerometers were mounted on the panels to measure the frequency and damping as shown in figure 2 and in the instrumentation schematic diagram, figure 3. The frequency and damping of the panels were determined from

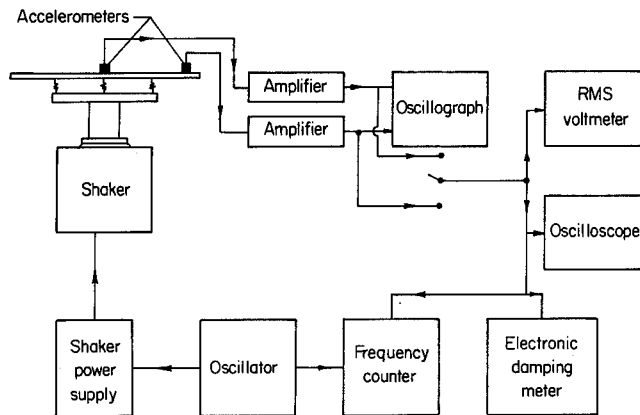

Figure 3.- Block diagram of instrumentation.

the accelerometer outputs by an electronic frequency counter and an electronic damping meter, respectively. The signals were constantly monitored on an oscilloscope and were recorded on a direct writing oscillograph.

The levels of vacuum in the chamber were determined by a Bourdon gage in the range from 1 atmosphere to 1 torr. A thermocouple-type gage was used from 1 torr to 10^{-3} torr and an ionization gage was used from 10^{-3} torr to the lowest pressure attainable.

PROCEDURE

The natural frequencies of the first three modes of vibration were obtained over a pressure range from 1 atmosphere to 10^{-6} torr by varying the frequency of excitation and recording the frequency of maximum acceleration response. The associated nodal patterns were determined at atmospheric pressure by means of "sand patterns" resulting from collection of a granular material at the node lines of the panels.

Damping in terms of logarithmic decrements was also determined over the pressure range from 1 atmosphere to 10^{-6} torr. A panel was excited at a natural frequency to the desired amplitude level, and the shaker was then deenergized so as to allow a free decay of panel amplitude. Before each damping measurement was taken, sufficient time was allowed for the signal from an accelerometer mounted on the shaker armature to decay to zero. The damping was measured at selected positions along the envelope of the acceleration time history by means of an electronic damping meter. The damping was specified in terms of logarithmic decrement

$$\delta = \frac{1}{N} \log_e \left[\frac{a_0}{a_n} \right] \quad (1)$$

where N is the number of cycles occurring over the acceleration amplitude range (a_0, a_n) .

ANALYSIS OF SUPPORT AND EXCITATION SYSTEM

In order to determine the effect of the support and excitation system on the vibrational characteristics of the panels, natural frequencies and nodal patterns of the panels mounted on the springs were calculated by linear bending theory and were compared with similar calculations for the panels with no support restraint. The method of solution, a finite-difference technique incorporating the principles of minimum potential energy, is developed for solid plates in reference 8. This technique, which utilized a high-speed digital computer, was particularly convenient since the potential energy resulting from support-spring stiffness could easily be incorporated into the total potential energy of the panels. For the purpose of setting up the finite-difference net, the panel was visualized as an assembly of 49 equal squares of side length l as shown in figure 4. The circular symbols represent the actual locations of the support springs which, for computational convenience, were located in the center of the selected squares.

From the computations, eigenvalues are obtained from which the panel frequencies are determined with the relation

$$f = \frac{\sqrt{\lambda}}{2\pi l^2} \sqrt{\frac{D}{2m}} \quad (2)$$

where λ is the eigenvalue obtained from the finite-difference calculation, l^2 is the area of each square, m is the mass per unit of area, and D is the flexural rigidity. The flexural rigidity of a homogeneous plate is given by

$$D = \frac{Eh^3}{12(1 - \mu^2)} \quad (3)$$

where E is the modulus of elasticity, h is the thickness, and μ is Poisson's ratio. For the sandwich panels the flexural rigidity may be written as

$$D = \frac{E_f(h^3 - h_c^3)}{12(1 - \mu_f^2)} + \frac{E_c h_c^3}{12(1 - \mu_c^2)} \quad (4)$$

where h and h_c are the total thickness of the panel and the core thickness, respectively, and the subscripts f and c denote the facing and core, respectively. For the

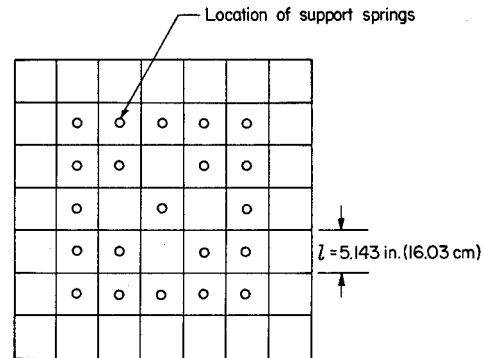

Figure 4.- Panel planform showing spring locations for frequency analysis.

panels used in this investigation, however, the core stiffness was negligible in comparison to the facing stiffness; thus, the flexural rigidity was approximated by

$$D = \frac{E_f (h^3 - h_c^3)}{12 (1 - \mu_f^2)} \quad (5)$$

The mode shapes of the panels were given by the finite-difference computations in terms of relative deflections of the midpoints of the squares which make up the finite-difference net.

Frequency predictions made by the use of equations (2) to (5) indicated that the support springs produced very slight increases in the natural frequency. As a check on these predictions, the natural frequencies obtained for the 5.2H panel on the spring support were compared with frequencies obtained for the panel suspended at nodal points and excited by impact from a solenoid-activated hammer. The experimental and predicted frequencies obtained for both systems of support are compared in table II. The spring support system increased the predicted frequency less than 1 percent for the first three modes. These predicted values were generally verified by experiment within the range of experimental accuracy.

TABLE II.- NATURAL FREQUENCIES OF 5.2H PANEL
WITH AND WITHOUT SPRING SUPPORT

Mode	Theoretical frequency, cps		Experimental frequency, cps	
	With	Without	With	Without
1	124.4	123.2	117.5	117.0
2	183.3	182.8	181.1	179.5
3	227.8	227.5	226.5	226.0

PRESENTATION AND DISCUSSION OF RESULTS

Frequency and Mode Shapes

Before the effect of pressure on the vibrational characteristics of the sandwich panels was considered, the first three natural frequencies and their corresponding nodal patterns were experimentally determined for each of the panels. These results along with the predicted frequency values, which included the effects of the spring stiffness, are shown in figure 5. The nodal patterns are photographs of the shapes determined for

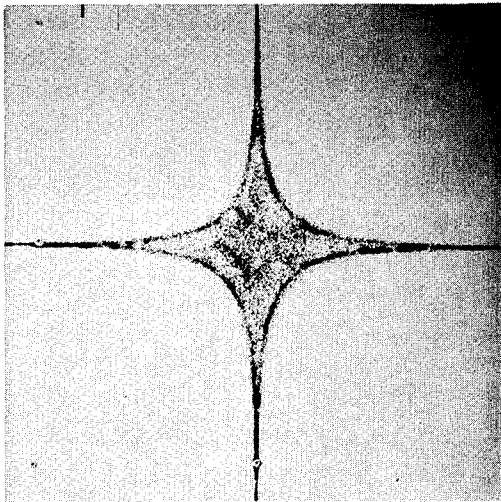

First mode

Panel	Natural frequency, cps	
	Experiment	Theory
5.2H	117.5	124.4
3.6H	120.4	130.9
10.1F	80.6	95.6
2.1F	88.5	158.2

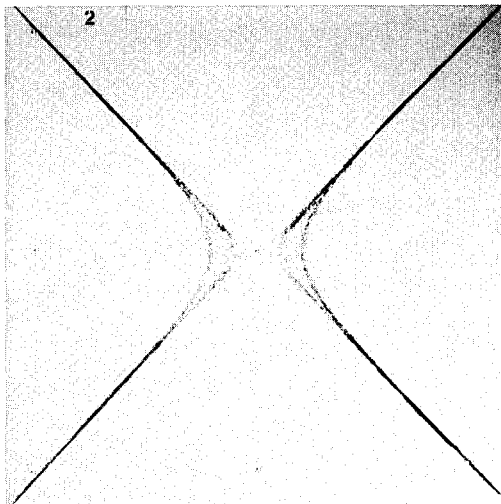

Second mode

Panel	Natural frequency, cps	
	Experiment	Theory
5.2H	181.1	183.3
3.6H	185.0	192.9
10.1F	128.2	140.8
2.1F	117.1	232.8

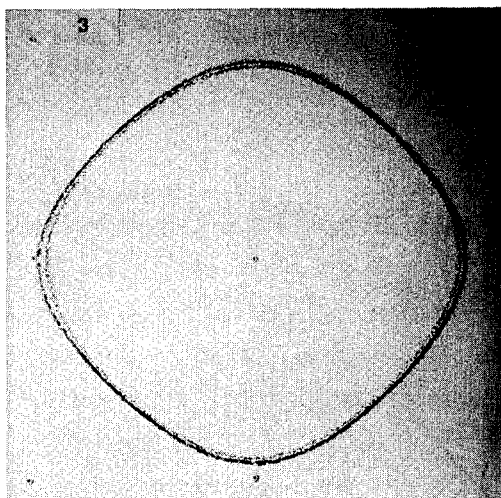

Third mode

Panel	Natural frequency, cps	
	Experiment	Theory
5.2H	226.5	227.8
3.6H	232.0	239.7
10.1F	158.0	175.2
2.1F	141.3	289.6

L-66-1193

Figure 5.- Panel nodal patterns and natural frequencies.

the 5.2H panel and are in excellent agreement with the shapes predicted by theory. Very similar nodal patterns were determined for the other panels. The experimental frequency values presented were obtained at a pressure of 1 torr to minimize air loading or apparent mass effects. The predicted and experimental values are in reasonable agreement for the honeycomb core panels and for the 10.1F panel; however, the experimental values for the 2.1F panel are approximately one-half the calculated values. This low density foam has a very low shear modulus, approximately 500 psi (34.47×10^5 N/m²), which allows a comparatively large transverse shear effect and a subsequent reduction in frequency. No known information is available to predict this frequency reduction for panels or plates with free edge conditions; however, predictions in reference 9 indicate that a simply supported sandwich panel with the same flexural rigidity, dimensions, and core shear modulus should have approximately one-half the first mode frequency predicted by classical plate theory, which neglects transverse shear. Similar calculations for the honeycomb panels and for the high-density-foam core panel predict frequency reductions due to transverse shear of about 2 and 10 percent, respectively.

Effect of Pressure on Natural Frequency

The pressure environment can alter frequency by producing an external air loading as well as by affecting the physical characteristics of the core materials. The air loading can be separated into two components: one component is in phase with the panel acceleration, and the other is in phase with the panel velocity. The first of these components or apparent mass affects the panel frequency, whereas the second affects the panel damping.

The effects of pressure on panel frequency are shown in figure 6. The first natural frequency of each panel is presented as a function of pressure ranging from 760 torr to 10^{-6} torr. No significant frequency changes occur below a pressure of 1 torr, which indicates that virtually no changes in material properties occur in this range of pressure. A significant effect, however, is noted at pressures above 1 torr. The details of this frequency-pressure relationship are shown in figure 7 as the ratio f_p/f_0 in percent, where f_p is the frequency experimentally determined at the pressure p and f_0 is the average value of the frequency data obtained at pressures below 1 torr. A 2-percent change in frequency with pressure is noted except in the case of the 2.1F panel, which has a frequency change of approximately 10 percent. Since each panel has the same area and mode shape, each should be acted upon by approximately the same effective air mass. Consequently, the lightest panel (2.1F) should experience the greatest change in frequency with changes in pressure. The magnitude of the apparent mass as determined from the frequency changes of the 3.6H, 5.2H, and 10.1F panels would account for or produce only one-half the observed frequency change for the 2.1F panel. The thickness of this panel was observed to increase with a decrease in pressure and calculations indicate that this increase in thickness could account for an additional 25 percent of the observed frequency

change. The remaining change in frequency is believed to be due to an increase in the shear rigidity of the core resulting from the slight core expansion and the increased pressure differential between the cell pressure and external pressure.

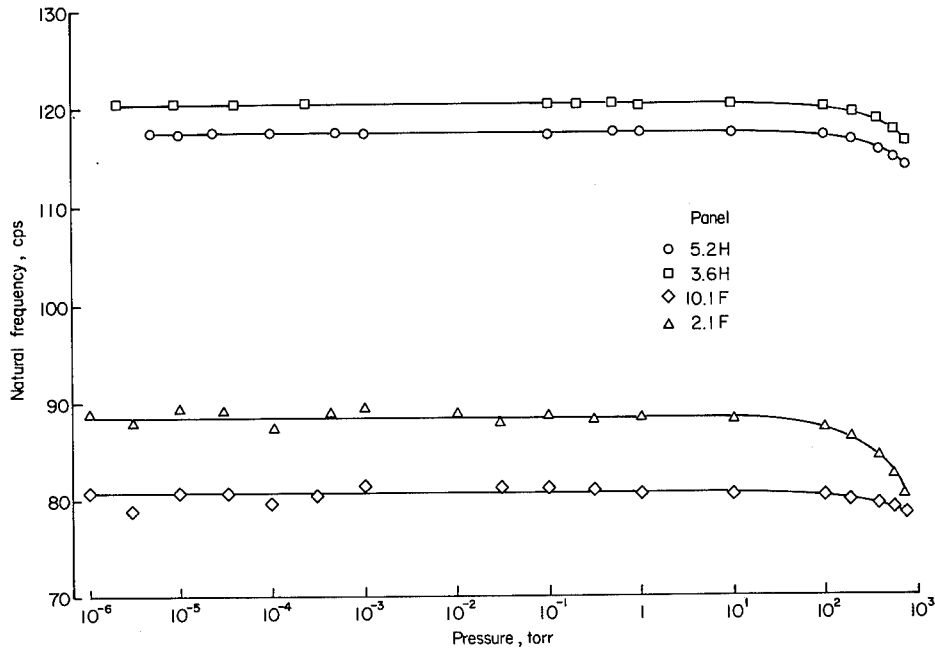

Figure 6.- Effect of pressure on panel frequency. First mode.

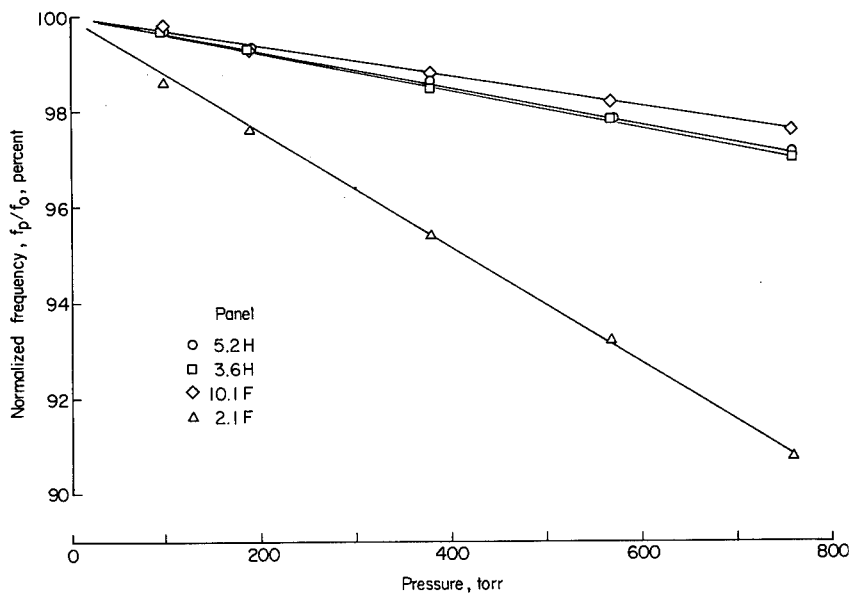

Figure 7.- Variation in panel frequency with pressure. First mode.

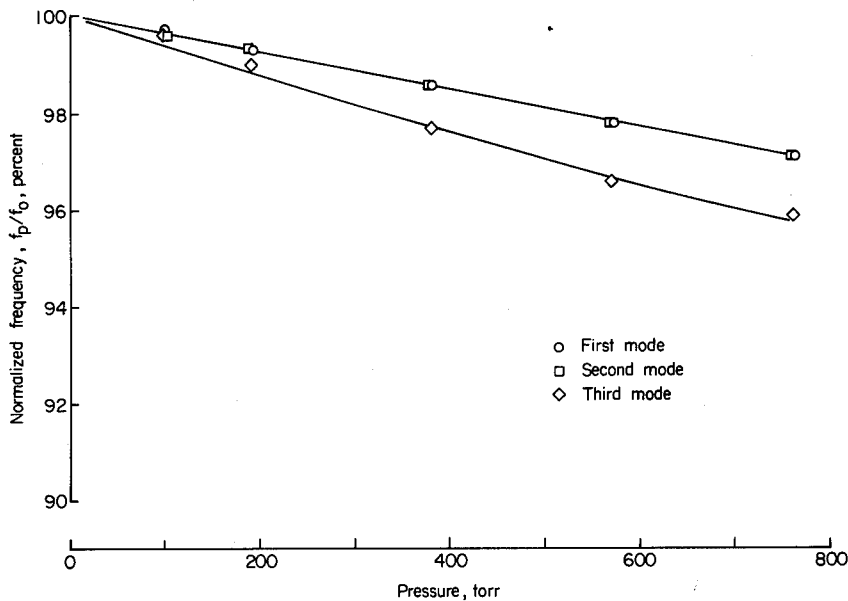

Figure 8.- Effect of pressure on frequency. First, second, and third modes; 5.2H panel.

The effect of pressure on the frequencies of the second and third modes of the panels is exemplified by data for the 5.2H panel shown in figure 8. The normalized frequency f_p/f_0 in percent is shown as a function of pressure for the first three modes of this panel. Essentially the same frequency-pressure dependence is noted for the first and second modes; however, a significantly greater change occurs for the third mode. This behavior may

be attributed to the similarity of the first two modes and to the much larger areas of the segments formed by the third mode. (See fig. 5.)

Effect of Pressure on Panel Damping

The damping-pressure relationship for the first vibration mode of the panels is presented in figure 9. No significant change in damping is noted in the pressure range between 1 torr and 10^{-6} torr. The structural damping of the foam core panels is significantly higher than that of the honeycomb core panels. Considerable change is noted, however, in the pressure range above 1 torr. Damping values obtained for the panels over this pressure range are shown in figure 10. The data indicate that the damping varies linearly with pressure and that the damping attributable to the presence of air at atmospheric pressure (760 torr) is less than the inherent structural damping. Because of the relatively high frequencies and low amplitudes, the observed change in damping with pressure is attributed to acoustic radiation rather than to the formation and shedding of vortices, since there is virtually no air flow over the panel edges. As predicted in reference 6, the acoustic radiation damping for the first mode of a simply supported plate mounted in a large baffle can be approximated by

$$\delta = \frac{64}{\pi^3} \frac{\rho S f}{m c}$$

where ρ is the air density, S is the plate area, f is the natural frequency of vibration, m is the plate mass per unit area, and c is the speed of sound in air. In the

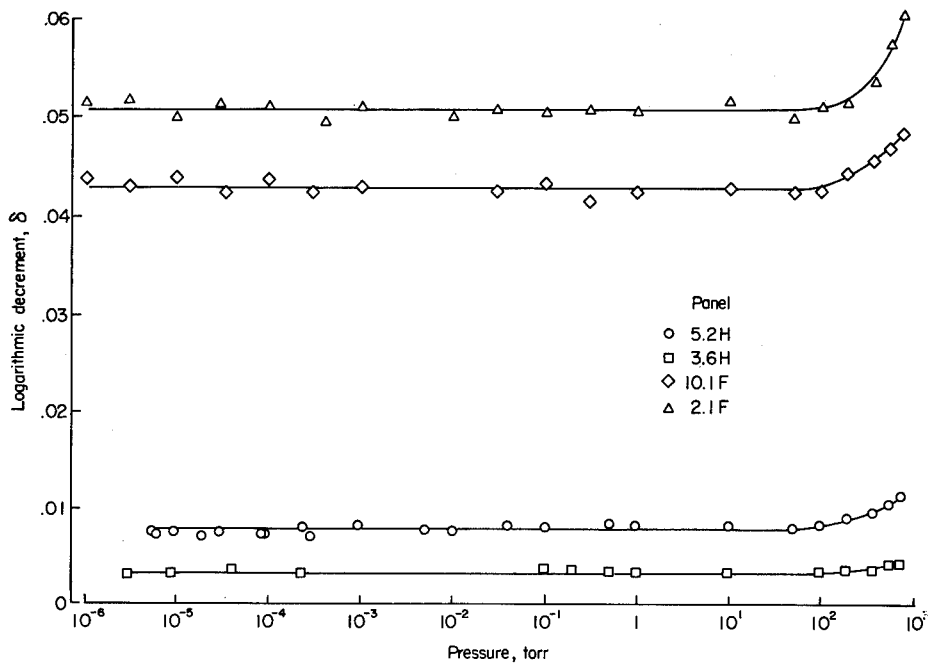

Figure 9.- Effect of pressure on panel damping. First mode.

present case, although there is qualitative agreement, the problem is much more complicated because of possible acoustic interaction between the segments produced by the mode shapes and also because of possible interaction between the two faces of the panels. The magnitude of these interactions and, hence, the magnitude of the total acoustic damping, is highly dependent on the acoustic wave length and the panel or modal segment size. If the wavelength is much less than the dimensions of the modal segments, the interaction between segments is small and each segment radiates as an independent source. If, on the other hand, the wavelength is on the order of or greater than the dimensions of the modal segments, the energy dissipated as acoustic radiation

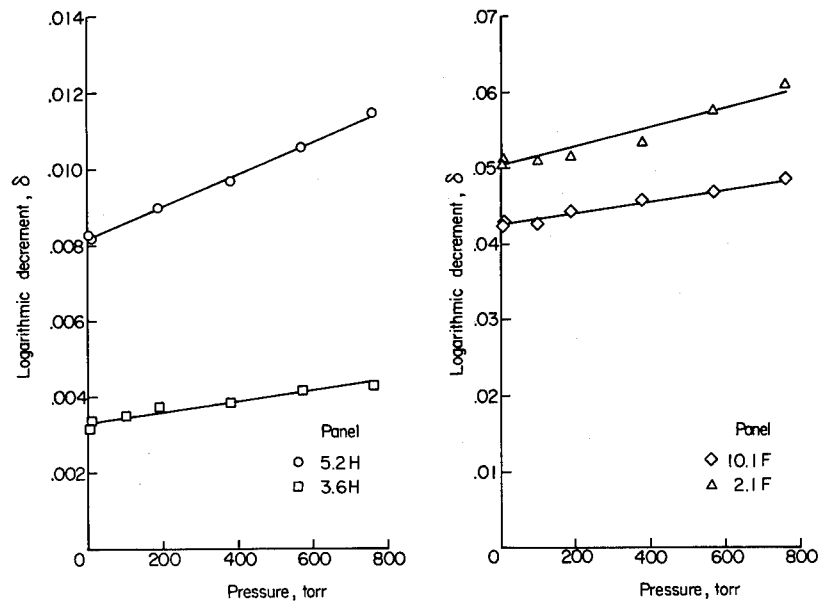

Figure 10.- Variation in panel damping with pressure. First mode.

by each segment is dependent upon the phase relationship between the segment and the acoustic pressure waves reaching it from the other segments. Consequently, the total panel damping can be either increased or decreased depending on the acoustic wavelength and distance between the modal segments. In the present investigation, the acoustic wavelengths in all cases are slightly greater than the modal segment dimensions.

An example of the effects of mode shape on the damping-pressure relationship is given in figure 11, where damping values of the first three modes of the 5.2H panel are

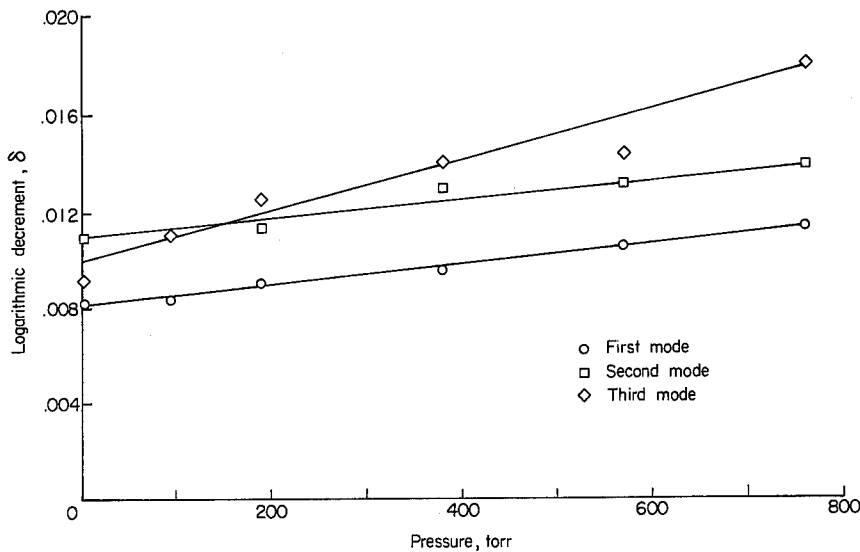

Figure 11.- Effect of pressure on damping. First, second, and third modes; 5.2H panel.

given as a function of pressure. Essentially the same magnitude of air damping is experienced by the first and second modes; however, the third mode experienced significantly greater air damping. As presented in reference 6, the first and second modes can be described as quadrupole acoustic sources and third mode, as a form of dipole. From the characteristics known about these types of sources, the above damping behavior is to be

expected, since a dipole is far more efficient as an acoustic source than is a quadrupole.

Effect of Amplitude on the Damping of the Panels

The effect of amplitude on the damping of the sandwich panels is illustrated in figure 12. The damping-amplitude relationships are given for the 5.2H and the 10.1F panels at both atmospheric pressure (760 torr) and 1 torr. There is approximately a 10-percent increase in damping in each case over the amplitude ranges investigated with the damping of the foam core panel showing the greatest amplitude dependency. For each panel, the air damping or difference in damping at atmospheric pressure and at 1 torr is essentially independent of amplitude, as is typical of damping due to acoustic radiation.

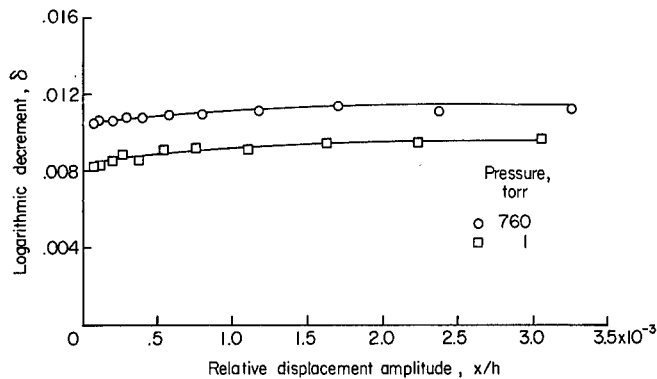

(a) First mode, 5.2H panel.

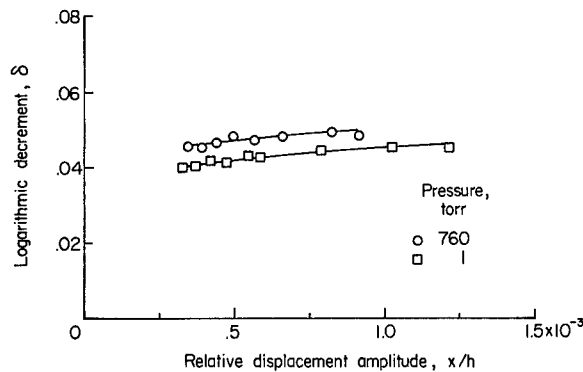

(b) First mode, 10.1F panel.

Figure 12.- Effect of vibration amplitude on panel damping.

CONCLUDING REMARKS

An investigation was conducted to determine the vibrational characteristics of sandwich panels in a pressure range from 760 torr (1 atmosphere) to 10^{-6} torr (1 torr = 133.3 N/m^2). The following conclusions are noted:

1. Virtually no changes in natural frequency or damping occur at pressures between 1 torr and 10^{-6} torr; however, significant changes in both natural frequency and damping occur in the pressure range between 1 atmosphere and 1 torr.

2. A reduction in pressure from 1 atmosphere to 1 torr results in an increase in natural frequency from 2 to 10 percent due to apparent mass effects and possible increases in panel thickness and shear rigidity.

3. A corresponding decrease in pressure results in a linear decrease in damping due to a reduction of acoustic radiation.

4. The effect of pressure on frequency and on damping is dependent upon the vibratory mode shape of the panel.

5. Neither the inherent structural damping nor the acoustic damping of the panels is strongly dependent on the amplitude of vibration.

6. Classical plate theory is applicable for obtaining frequencies and nodal patterns for the sandwich panels investigated, except in cases of extremely low core shear rigidity.

7. The spring bed support and excitation system provides a practical method for vibrational testing of panels in a vacuum environment.

Langley Research Center,

National Aeronautics and Space Administration,

Langley Station, Hampton, Va., March 17, 1966.

REFERENCES

1. Rayleigh, (Lord): The Theory of Sound. First Am. ed., vol. II, Dover Publ., 1945.
2. Fung, Y. C.: An Introduction to the Theory of Aeroelasticity. GALCIT Aeronautical Series. John Wiley & Sons, Inc., c.1955.
3. Ungar, Eric E.: Energy Dissipation at Structural Joints; Mechanisms and Magnitudes. FDL-TDR-64-98, U.S. Air Force, Aug. 1964.
4. Stephens, David G.; and Scavullo, Maurice A.: Investigation of Air Damping of Circular and Rectangular Plates, a Cylinder, and a Sphere. NASA TN D-1865, 1965.
5. Mangiorotty, R. A.: Acoustic Radiation Damping of Vibrating Structures. J. Acoust. Soc. Am., vol. 35, no. 3, Mar. 1963, pp. 369-377.
6. Hubbard, Harvey H.; and Houbolt, John C.: Vibration Induced by Acoustic Waves. Engineering Design and Environmental Conditions. Vol. 3 of Shock and Vibration Handbook, Cyril M. Harris and Charles E. Crede, eds., McGraw-Hill Book Co., Inc., c.1961, pp. 48-1 - 48-57.
7. Mechtly, E. A.: The International System of Units - Physical Constants and Conversion Factors. NASA SP-7012, 1964.
8. Walton, William C., Jr.: Applications of a General Finite-Difference Method for Calculating Bending Deformations of Solid Plates. NASA TN D-536, 1960.
9. Jacobson, M. J.: Effects of Orthotropic Cores on the Free Vibrations of Sandwich Plates. Shock Vib. Bull., Bull. 35, Pt. 3, U.S. Dept. Defense, Jan. 1966, pp. 9-14.

"The aeronautical and space activities of the United States shall be conducted so as to contribute . . . to the expansion of human knowledge of phenomena in the atmosphere and space. The Administration shall provide for the widest practicable and appropriate dissemination of information concerning its activities and the results thereof."

—NATIONAL AERONAUTICS AND SPACE ACT OF 1958

NASA SCIENTIFIC AND TECHNICAL PUBLICATIONS

TECHNICAL REPORTS: Scientific and technical information considered important, complete, and a lasting contribution to existing knowledge.

TECHNICAL NOTES: Information less broad in scope but nevertheless of importance as a contribution to existing knowledge.

TECHNICAL MEMORANDUMS: Information receiving limited distribution because of preliminary data, security classification, or other reasons.

CONTRACTOR REPORTS: Technical information generated in connection with a NASA contract or grant and released under NASA auspices.

TECHNICAL TRANSLATIONS: Information published in a foreign language considered to merit NASA distribution in English.

TECHNICAL REPRINTS: Information derived from NASA activities and initially published in the form of journal articles.

SPECIAL PUBLICATIONS: Information derived from or of value to NASA activities but not necessarily reporting the results of individual NASA-programmed scientific efforts. Publications include conference proceedings, monographs, data compilations, handbooks, sourcebooks, and special bibliographies.

Details on the availability of these publications may be obtained from:

SCIENTIFIC AND TECHNICAL INFORMATION DIVISION
NATIONAL AERONAUTICS AND SPACE ADMINISTRATION
Washington, D.C. 20546