

DOT/FAA/AR-96/15

Office of Aviation Research
Washington, D.C. 20591

The Development of a Flammability Test Method for Aircraft Blankets

Patricia Cahill

Airport and Aircraft Safety
Research and Development Division
FAA Technical Center
Atlantic City International Airport, NJ 08405

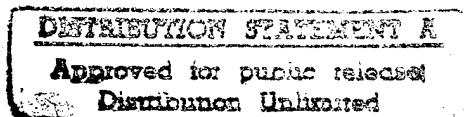

March 1996

Final Report

19960430 095

This document is available to the U.S. public
through the National Technical Information
Service, Springfield, Virginia 22161.



U.S. Department of Transportation
Federal Aviation Administration

DOT QUALITY IMPROVEMENT L

NOTICE

This document is disseminated under the sponsorship of the U.S. Department of Transportation in the interest of information exchange. The United States Government assumes no liability for the contents or use thereof. The United States Government does not endorse products or manufacturers. Trade or manufacturer's names appear herein solely because they are considered essential to the objective of this report.

Technical Report Documentation Page

1. Report No. DOT/FAA/AR-96/15		2. Government Accession No.		3. Recipient's Catalog No.	
4. Title and Subtitle THE DEVELOPMENT OF A FLAMMABILITY TEST METHOD FOR AIRCRAFT BLANKETS				5. Report Date March 1996	
				6. Performing Organization Code AAR-422	
7. Author(s) Patricia Cahill				8. Performing Organization Report No. DOT/FAA/AR-96/15	
9. Performing Organization Name and Address Airport and Aircraft Safety Research and Development Division FAA Technical Center Atlantic City International Airport, NJ 08405				10. Work Unit No. (TRAVIS)	
				11. Contract or Grant No.	
12. Sponsoring Agency Name and Address U.S. Department of Transportation Federal Aviation Administration Office of Aviation Research Washington, D.C. 20591				13. Type of Report and Period Covered Final Report	
				14. Sponsoring Agency Code	
15. Supplementary Notes					
16. Abstract Flammability testing of aircraft blankets was conducted in order to develop a fire performance test method and performance criteria for blankets supplied to commercial aircraft operators. Aircraft blankets were subjected to vertical Bunsen burner testing, 4-ply vertical testing, full-scale match and cigarette testing, and single- and 4-ply horizontal testing. It was found that the 4-ply horizontal test correlates well with the full-scale match tests, produces consistent test results, and realistically evaluates ease of ignition.					
17. Key Words Aircraft blankets, Polyester, Flammability, Material fire tests				18. Distribution Statement This document is available to the public through the National Technical Information Service (NTIS), Springfield, Virginia 22161.	
19. Security Classif. (of this report) Unclassified		20. Security Classif. (of this page) Unclassified		21. No. of Pages 34	22. Price

TABLE OF CONTENTS

	Page
EXECUTIVE SUMMARY	v
INTRODUCTION	1
Purpose	1
Background	1
DISCUSSION	1
Aircraft Blanket Materials	1
Experimental Flammability Testing of Polyester and Nonpolyester Blankets	2
Single-Ply Vertical Tests	2
Single-Ply Horizontal Tests	2
Match Test	3
Full-Scale Match and Cigarette Tests	3
4-Ply Vertical Tests	3
4-Ply Horizontal Tests	3
Nonpolyester Blankets	4
Polyester Blankets	4
Flammability Testing of Washed Polyester Blankets	4
Polyester Blanket Samples	4
Flammability Test Results	4
CONCLUSIONS	5
REFERENCES	6
APPENDICES	
A—Recommended Procedure for the 4-Ply Horizontal Flammability Test Method for Aircraft Blankets	
B—Test Specimen Holder Construction Drawings	

LIST OF TABLES

Table		Page
1	Test Samples	7
2	Vertical Bunsen Burner Tests	8
3	Single-Ply Horizontal Tests	9
4	Match Test Results (Three Tests)	10
5	Full-Scale Match and Cigarette Tests	11
6	4-Ply Vertical Bunsen Burner Tests	12
7	4-Ply Horizontal Tests	13
8	One Washing of Polyester Blankets	14
9	Two Washings of Polyester Blankets	15
10	Five Washings of Polyester Blankets	16
11	Ten Washings of Polyester Blankets	17
12	Fifteen Washings of Polyester Blankets	18

EXECUTIVE SUMMARY

On November 28, 1993, during gate departure of a Northwest Airlines 727 aircraft, the pilot declared an emergency after a fire was reported in an overhead stowage bin. Upon completion of their investigation, the Transportation Safety Board of Canada determined that the original source of fuel for the fire was the 100 percent polyester airline blankets stored in the overhead stowage bin. The Federal Aviation Administration (FAA) does not require flammability testing of airline blankets. Therefore in light of the above incident, the United States (U.S.) National Transportation Safety Board asked the FAA to develop a fire performance criteria for blankets supplied to commercial airline operators. After extensive testing performed at the FAA Technical Center, a 4-ply horizontal test method had been developed. The test involves mounting four layers of the blanket in an 8-inch-square metal test fixture and subjecting the material to a Bunsen burner flame from below for 12 seconds. The proposed method produces consistent test results, correlates well with full-scale testing, and is more realistic since the blankets are folded when stored in the aircraft stowage bins.

INTRODUCTION

PURPOSE.

The purpose of this work was to examine the flammability of airline blankets and to develop a fire test method that realistically evaluates the blanket's ease of ignition and flame propagation.

BACKGROUND.

On November 28, 1993, the pilot of a Northwest Airlines B727-200 aircraft declared an emergency after a fire was reported in an overhead stowage bin. The fire was noticed just as the aircraft was being pushed back from the loading gate at Dorval International Airport. The fire was extinguished by crew members and all passengers were safely evacuated.

The stowage bin involved in the fire contained a personal carry-on bag and five 100 percent polyester airline blankets in two separate piles. The blankets were supplied by two different manufacturers. Upon completion of their investigation, the Transportation Safety Board (TSB) of Canada determined that the original source of fuel for the fire was the 100 percent polyester airline blankets. This conclusion was based on TSB testing of a section of unburned blanket. In their first test, a lit match was placed at the edge of the blanket. In their second test, a lit match was placed directly on top of the blanket. In both cases, the blanket ignited and rapid propagation of flame was observed [1].

The Federal Aviation Administration (FAA) does not require flammability testing of airline blankets. Therefore in light of the above incident, the U.S. National Transportation Safety Board (NTSB) asked the FAA to develop a fire performance test method and performance criteria for blankets supplied to commercial airline operators [2]. Currently, many airlines only use blankets that meet the FAA vertical Bunsen burner test criteria specified in Federal Aviation Regulation (FAR) 25.853. However, this test may be inappropriate as a measurement of ignitability for certain types of blankets since the polyester blankets involved in the Northwest Airlines B727-200 fire met the test criteria.

DISCUSSION

AIRCRAFT BLANKET MATERIALS.

Airlines select blankets for coach and first class based on durability, weight, compactness, softness, and cost. While blankets fabricated from materials such as loom woven 60% wool/40% acrylic, nonwoven 100% acrylic, loom woven 100% cotton, and modacrylic are used by some of the airlines, the majority of the air carriers buy 100% polyester circular knit or 100% polyester warped knit blankets. (Reference table 1)

Polyester fiber is poly(ethyleneterephthalate). While poly(ethyleneterephthalate) is flammable, many polyester textiles will not ignite because the fabric melts away from a small ignition source or may self-extinguish by drip out. These mechanisms tend to be highly dependent on factors

such as weight, density, staple length, weave structure, and pile height. Therefore, ignition and total consumption may occur given the type of polyester sample tested and the nature of the test conditions.

Reference 3 states "to improve fire retardance, the molecular composition of poly-(ethyleneterephthalate) can be altered to contain bromine or by using bis(hydroxyethoxy) tetrabromobisphenyl A to replace some of the ethyleneglycol. Antimony oxide then can be included in the formulation to enhance the fire retardance effectiveness. Bromine can also be introduced by means of an additive incorporated during the melt spinning process, or it can be applied to the finished fabric using emulsion of tris (2,3-dibromopropyl phosphate)."

EXPERIMENTAL FLAMMABILITY TESTING OF POLYESTER AND NONPOLYESTER BLANKETS.

Ignition time, flameout time, and drip flame time were the criteria selected for horizontal testing. This criteria was also used for vertical testing along with the addition of burn length. A definition of each follows:

Ignition Time—Ignition time is the length of time the burner flame is applied to the specimen. It is 12 seconds for this test.

Flameout Time—Flame time is the time in seconds that the specimen continues to flame after the burner flame is removed from beneath the specimen. Surface burning that results in a glow but not in a flame is not included.

Drip Flame Time—Drip flame time is the time in seconds that any flaming material continues to flame after falling from the specimen to the floor of the chamber. If no material falls from the specimen, the drip flame time is reported to be 0 seconds, and the notation "No Drip" is also reported. If there is more than one drip, the drip flame time reported is that of the longest flaming drip. If succeeding flaming drips reignite earlier drips that flamed, the drip flame time reported is the total of all flaming drips.

The allowable burn length = eight inches, allowable flameout time = 15 seconds and allowable drip flame time = 5 seconds.

SINGLE-PLY VERTICAL TESTS. Twelve-second vertical Bunsen burner testing was performed on the aircraft blankets per FAR 25.853. Table 2 summarizes the results. The data indicate that all of the polyester samples had burn lengths, flameout times, and drip flame time all within specification. This method could not distinguish the relative ignitability among the samples. Drip out and shrinkage were the primary means by which the blankets escaped ignition.

SINGLE-PLY HORIZONTAL TESTS. Eleven- by eleven-inch samples were cut from each test blanket. Each sample was placed in the test fixture shown in figure B-4. While the actual area in the test rig is eight by eight inches, the test blanket samples were cut larger in order to pull them taut. The fixture was mounted horizontally in the test chamber. Each sample was exposed to a

Bunsen burner flame placed under the geometric center of the test blanket for 12 seconds. Table 3 summarizes the results.

The average flameout time for two different polyester blankets, E and G, exceeded the allowable 15-second maximum. Although in each case, only one out of the three samples of each type tested failed. This method did not produce consistent results. Hole formation and shrinkage were prevalent and appeared to inhibit ignition.

MATCH TESTS. Three 12- by 12-inch samples were cut from each test blanket. Each sample was individually crumpled into a ball and placed in a fire test chamber. A lit match was placed on a corner of sample. Table 4 summarizes the test results. The polyester test data showed that only material, E, (one of three samples) was consumed during this test. The other polyester samples shrunk back, melted, and self-extinguished by drip out.

FULL-SCALE MATCH AND CIGARETTE TESTS. In this series of tests, one blanket of each type was subjected to a lit cigarette and one blanket of each type was subjected to lit matches. The blankets were folded in the same configuration as received by the airlines. The lit cigarette was placed in a middle layer at the geometric center of each blanket. The lit matches were placed at two adjacent corners and on top of the blanket at the geometric center. Table 5 summarizes the results.

One polyester blanket was totally consumed during the full-scale match test. This same blanket (E) did not fail flameout or burn length when tested vertically. All other polyester blankets exhibited minimal flame propagation with the typical shrinking and melting. Cigarettes did not ignite any of the blankets tested.

4-PLY VERTICAL TESTS. Each test blanket was folded in half and then folded again resulting in a 4-ply (4 layer) configuration. Three samples of each blanket were cut into 3- by 12-inch test specimens. They were tested in accordance with FAR 25.853. Table 6 summarizes the test results.

By folding the blanket into a 4-ply (layer) configuration, it was initially thought that the increased mass might help to eliminate flame extinguishment by drip out. While more flameout time failures were observed, consistent test results for all polyester samples could not be achieved.

4-PLY HORIZONTAL TESTS. Each test blanket was folded in half and then folded again resulting in a 4-ply configuration. Three pieces of each blanket were cut into 11- by 11-inch test specimens. The same procedure was followed per the single-ply horizontal test. Table 7 summarizes the results.

Using the 15-second maximum flameout time as the pass/fail criterion, blanket E consistently failed this test method. Furthermore, all of the samples were consumed as was the case when they were subjected to full-scale match testing. In comparing the 4-ply test data of all other polyester blankets with full-scale match test data, a good correlation of results can be seen.

A detailed description of the recommended 4-ply horizontal test method can be found in appendix A of this report.

NONPOLYESTER BLANKETS. The data in the previous referenced tables clearly show that test blankets A, F, and I are highly flammable and that they failed all the vertical and horizontal tests. Furthermore, the majority of these blanket samples were totally consumed during both full- and small-scale testing. A failure means that the average flame time after removal of the flame source exceeded 15 seconds and/or drippings continued to flame more than an average of 5 seconds after falling. This criteria has been adopted for both vertical and horizontal testing. In addition, the average burn length for samples tested vertically cannot exceed 8 inches. Test blankets H and J performed well in all phases of testing. While not in service at this time, the 100% Flame Retardant (FR) treated wool blanket (H) is presently being evaluated for future use.

The 100% modacrylic blanket (J) is not commonly used by American carriers. Thermal decomposition testing performed at the FAA Technical Center demonstrated that modacrylics give off significant quantities of hydrogen cyanide [4].

POLYESTER BLANKETS. The two 100% polyester circular knit blankets (B and C) performed well in all phases of the test program. From table 1, it can be seen that blankets B and C are heavier than the other polyester blankets tested. Blanket D also performed well. This particular blanket was the only FR treated polyester blanket tested. Blanket G, the lightest weight polyester blanket, passed the regulation Bunsen burner test. However, it failed flameout time when folded in the 4-ply configuration and tested vertically. From table 3, it can be seen that only one of three samples failed the single-ply horizontal test. Blanket G performed well in all other testing. Blanket E passed the vertical Bunsen burner test but failed flameout time when folded in the 4-ply configuration and tested vertically (table 6). In this series of testing, two of the three samples failed. Blanket E also failed flameout time when tested horizontally in the single-ply configuration. From table 3, it can be seen that only one out of the three samples tested failed. Blanket E consistently failed (3/3 samples) when folded in the 4-ply configuration and tested horizontally. Furthermore, the drips were significant ignition sources. From table 4, it can be seen that only one of three samples failed the small-scale match test. In the full-scale series of testing, blanket E was totally consumed in the match test but did not ignite during the cigarette test.

FLAMMABILITY TESTING OF WASHED POLYESTER BLANKETS.

POLYESTER BLANKET SAMPLES. All of the polyester blankets (B, C, D, E, and G) were sent to a laundry which specializes in washing aircraft blankets. One of each type of blanket was washed 1, 2, 5, 10, and 15 times. The blankets were subjected to vertical Bunsen burner, 4-ply horizontal and full-scale match testing. Tables 8, 9, 10, 11, and 12 summarize the test results.

FLAMMABILITY TEST RESULTS. A comparison of the new and washed polyester blankets vertical Bunsen burner test results showed no significant differences. In some cases, the burn lengths were identical. Flameout times were also very similar with the exception of blanket E, which failed flameout time after five washings but passed when new. For some materials,

flameout time got smaller with more washings; in fact, flameout time was smallest—overall—with 15 washings. The 4-ply horizontal flameout time test results were slightly higher for blankets C and D after two washings compared to new C and D blankets. Blanket G, which immediately self-extinguished when new, continued to burn after one, two, and five washings, and its flameout times were considerably longer. Blanket E performed poorly as it did when tested new. All of blanket E's test samples were totally consumed with the exception of the sample tested after 15 washings. Approximately 90% of that sample was consumed. The results in the full-scale match tests were quite similar for both new and washed blankets. Again, blanket E was totally consumed when tested after each of the washing cycles.

CONCLUSIONS

1. The 4-ply horizontal test method produced consistent test results, correlated well with the full-scale match tests, and was more realistic since the blankets are folded when stored in the aircraft stowbins
2. The 60% wool/40% acrylic, the 100% acrylic, and the 100% cotton blankets were the most flammable and were consumed during each test.
3. The 100% FR treated wool and 100% FR treated modacrylic blankets exhibited the greatest resistance to ignition.
4. The FR treated 100% polyester blanket performed well. After 15 washings, it appeared that the FR treatment did not wash out.
5. The 100% polyester circular knit blankets (one of the two types of blankets believed to be the fuel source in the Northwest B727 incident) performed well. Both the new and washed blankets had similar test results.
6. Blanket G (the lightest weight polyester blanket) passed all flammability testing when new but behaved erratically after washing. Vertical burn test data for the washed blankets were very similar to new blanket data. However, during the 4-ply horizontal tests, flaming continued (after burner removal) after the first, second, and fifth washings although no flaming was noted after the tenth or fifteenth washing. Very little flame spread was noted during the full-scale match tests.
7. The 100% polyester warped knit blanket (E) passed vertical testing when new and when washed but consistently failed 4-ply horizontal testing (new and washed) and was consumed each time. This blanket also failed full-scale match testing.
8. Cigarettes did not ignite any of the blankets tested in this program.

REFERENCES

1. Foot, J.E., Engineering Report LP 154/97, Fire Source Analysis, Boeing 727-200, N27845, November 28, 1993.
2. David Hinson, letter, September 26, 1994, re: Safety recommendation A-94-131, James E. Hall, Acting Chairman, NTSB, 490 L'Enfant Plaza East, S.W., Washington, D.C.
3. National Research Council. Committee on Fire Safety Aspects of Polymeric Materials. Fire Safety Aspects of Polymeric Materials: V.1, Materials: State of the Art Report, Washington, D.C., National Academy of Sciences; 1977.
4. Spurgeon, J.C., Speitel, L.C., and Feher, R.E., "Thermal Decomposition Products of Aircraft Interior Materials," FAA-RD-77-20, April 1977.

TABLE 1. TEST SAMPLES

This table describes the aircraft blankets evaluated in the study.

Blanket	Composition	
A.	60% wool/40% acrylic	gray and white striped—non-FR treated
B.	100% polyester circular knit, 6.6 oz/yd ²	royal blue—non-FR treated
C.	100% polyester circular knit, 6.6oz/yd ²	navy blue—non-FR treated
D.	100% polyester warp knit, 3.0 oz/yd ²	maroon—FR treated*
E.	100% polyester warp knit, 4.2 oz/yd ²	navy blue—non-FR treated
F.	100% cotton loom woven	lavender—non-FR treated
G.	100% polyester warp knit (light wrap), 2.25 oz/yd ²	navy blue—non-FR treated
H.	100% wool (test blanket, not currently used)	navy blue—FR treated
I.	100% acrylic	navy blue—non-FR treated
J.	100% modacrylic	maroon—FR treated

* Flame Retardent (FR) treatment was incorporated during manufacturing process.

TABLE 2. VERTICAL BUNSEN BURNER TESTS
(data are the averages of three tests)

Blanket	Code	Flameout Time (seconds)	Burn Length (inches)	Flame Time Drippings (seconds)
A.	W/A	34.7	12.0	9.2
B.	PE	3.4	5.4	0
C.	PE	7.1	5.2	0
D.	FR PE	0	6.1	0
E.	PE	4.1	4.9	4.1
F.	C	8.26 (flame and glow)	12.0	0
G.	PE	0	5.5	0
H.	FR W	0	4.2	0
I.	A	50.9	2.0	0
J.	FR M	0	7.12	0

Key: W/A - Wool/Acrylic, PE - Polyester, C - Cotton, W - Wool, A - Acrylic, M - Modacrylic, FR - Flame Retardant

TABLE 3. SINGLE-PLY HORIZONTAL TESTS
(data are the averages of three tests)

Blanket	Code	Flameout Time (seconds)	Flame Time Drippings (seconds)	Notes
A.	W/A	144.6	24.6	all samples totally consumed.
B.	PE	1.2	0	hole formed and material shrunk back from flame.
C.	PE	1.3	0	hole formed and material shrunk back from flame.
D.	FR PE	0	0	hole formed—material charred
E.	PE	27.6	1 sample—7 second drippings	one sample totally consumed, samples 2 and 3—hole formed, no flame propagation
F.	C	125.1	0	all samples totally consumed—glowing burn.
G.	PE	50.7	1 sample—11 second drippings	one sample totally consumed, samples 2 and 3—hole formed, no flame propagation.
H.	FR W	2.9	0	all samples charred, no flame propagation.
I.	A	101.3	14.6	all samples totally consumed—very smoky.
J.	FR M	2.4	0	all samples curled back and charred—very smoky.

Key: W/A - Wool/Acrylic, PE - Polyester, C - Cotton, W - Wool, A - Acrylic, M - Modacrylic, FR - Flame Retardant

TABLE 4. MATCH TEST RESULTS (THREE TESTS)

Blanket	Code	Notes
A	W/A	all samples were 50% to 90% consumed—charring occurred—dense acrid smoke
B.	PE	minor flaming—self-extinguished by drip out
C.	PE	minor flaming—self-extinguished by drip out
D.	FR PE	materials shrunk back from flame—no propagation
E.	PE	samples 1 and 2 did not propagate the fire—melting occurred—sample 3 was totally consumed—flaming drips were new ignition sources
F.	C	samples totally consumed—glowing flame and afterglow
G.	PE	no flame propagation—materials shrunk back and would not ignite.
H.	FR W	samples charred—no flame propagation
I	A	samples totally consumed—very smoky
J.	FR M	smoky small areas of char—no flame propagation

Key: W/A - Wool/Acrylic, PE - Polyester, C - Cotton, W - Wool, A - Acrylic, M - Modacrylic, FR - Flame Retardant

TABLE 5. FULL-SCALE MATCH AND CIGARETTE TESTS

Blanket Code	Match	Cigarette
A. W/A	25% of the blanket consumed—material charred—dense smoke	blanket would not ignite—entire cigarette consumed—holes—scorching
B. PE	minimal flame propagation—flaming drips self-extinguished—material shrank back from flame	blanket would not ignite—shrank and melted—holes formed
C. PE	minimal flame propagation—flaming drips self-extinguished—material shrank back from flame	blanket would not ignite—shrank and melted—holes formed
D. FR PE	material shrank and melted—holes formed—no flame propagation	smoldered—no flame spread—holes formed
E. PE	blanket totally consumed	no ignition—material shrank and melted
F. C	blanket consumed—flaming and glowing burn—approximately 40 minutes in duration	blanket not available for testing
G. PE	no ignition—material melted and shrank back—holes formed—drippings did not ignite material	no ignition—blanket shrank and melted—holes formed
H. FR W	blanket material shrank back and charred—no flame propagation	no ignition—material charred—scorched
I. A	blanket totally consumed	no ignition—holes formed—blanket shrank and curled
J. FR M	no ignition—material charred—holes formed	no ignition—charred and holes formed

Key: W/A - Wool/Acrylic, PE - Polyester, C - Cotton, W - Wool, A - Acrylic, M - Modacrylic

TABLE 6. 4-PLY VERTICAL BUNSEN BURNER TESTS
(data are the averages of three tests)

Blanket	Code	Flameout Time (seconds)	Burn Length (inches)	Flame Time Drippings (seconds)
A.	W/A	99.3	12	18.9
B.	PE	12.1	4.5	1.6
C.	PE	12.5	4.4	1.0
D.	FR PE	0.56	4.8	0
E.	PE	473	5.6	13.0
F.	C	137.6 (flame and glow)	12.0	0
G.	PE	18.2	4.3	0
H.	FR W	0	5.1	0
I.	A	91.5	12.0	11.0
J.	FR M	0	6.8	0

Key: W/A - Wool/Acrylic, PE - Polyester, C - Cotton, W - Wool, A - Acrylic, M - Modacrylic

TABLE 7. 4-PLY HORIZONTAL TESTS
(data are the averages of three tests)

Blanket	Code	Flame Out Time (seconds)	Flame Time Drippings (seconds)	Notes
A.	W/A	226.3	9.0	all samples totally consumed—vast quantities of smoke
B.	PE	3.2	0	all samples shrunk and curled—hole formed.
C.	PE	3.0	0	all samples shrunk and curled—hole formed.
D.	FR PE	2.9	0	hole formed—all samples formed charred areas around hole.
E.	PE	113.3	14.9	all samples consumed—drips acted as secondary ignition source.
F.	C	501.2	0	two samples—flaming and glowing—85% consumed—third sample—bottom two layers consumed—glowing burn.
G.	PE	0	0	hole formed in all three samples—no flame propagation.
H.	FR W	4.8	0	hole formed in all three samples—all charred around edges of each layer.
I.	A	213.0	14.6	all samples totally consumed.
J.	FR M	0	0	hole formed in all samples—char formed around edges of all four layers.

Key: W/A - Wool/Acrylic, PE - Polyester, C - Cotton, W - Wool, A - Acrylic, M - Modacrylic, FR - Flame Retardant

TABLE 8. ONE WASHING OF POLYESTER BLANKETS

Blanket Code	Vertical (Average of Three Tests)			4-Ply Horizontal		Full-Scale Match	Notes
	Burn Length	Flameout Time (second)	Flameout Drippings	Flameout Time (second)	Flameout Drippings		
B.	5.9	5.8	0	0	0		material shrank and melted back—holes formed—no ignition
C.	4.9	5.1	0	7	0		material melted and shrank back—holes formed—no ignition
D.	5.7	5.8	0	0	0		no ignition—shrank back
E.	7.0	4.9	1	167	35		blanket consumed
G.	6.3	6.5	0	18	7		small amount of flame propagation—holes formed.

TABLE 9. TWO WASHINGS OF POLYESTER BLANKETS

Blanket Code	Vertical (Average of Three Tests)						4-Ply Horizontal		Full-Scale Match	Notes
	Burn Length	Flameout Time (second)	Flameout Drippings	Flameout Time (second)	Flameout Drippings	Flameout Time (second)	Flameout Drippings			
B.	6.1	3.3	0	0	0	0	0	0	material shrank—holes—no flame propagation	
C.	5.5	2.8	0	0	7	0	0	0	material shrank—holes—no flame propagation	
D.	6.0	0	0	0	13	0	0	0	edge binding thread ignited—fast burning—self-extinguished—holes formed	
E.	5.25	0	0	0	77	13	13	13	approximately 95% consumed	
G.	5.7	0	0	0	26	11	11	11	material melted and shrank rapidly—very minimal flame propagation	

TABLE 10. FIVE WASHINGS OF POLYESTER BLANKETS

Blanket Code	Vertical (Average of Three Tests)			4-Ply Horizontal		Full-Scale Match	Notes
	Burn Length	Flameout Time (second)	Flameout Drippings	Flameout Time (second)	Flameout Drippings		
B.	5.4	0	0	0	0		material shrank—holes formed—no flame propagation
C.	5.6	0	0	0	0		material shrank—holes formed—no flame propagation
D.	5.8	0	0	11	0		holes formed—material shrank back from flame
E.	6.0	40.5	3.6	144	39		blanket consumed by fire
G.	5.6	0	0	50	2		approximately 4 inches of burning along edge (thread)—self-extinguished—holes formed

TABLE 11. TEN WASHINGS OF POLYESTER BLANKETS

Blanket Code	Vertical (Average of Three Tests)			4-Ply Horizontal		Full-Scale Match	Notes
	Burn Length	Flameout Time (second)	Flameout Drippings	Flameout Time (second)	Flameout Drippings		
B.	4.8	0	0	0	0		material shrank—holes formed
C.	5.5	1.8	0	0	0		material shrank—holes formed
D.	6.4	0	0	0	0		holes formed—blanket shrank
E.	4.5	0	0	137	8		blanket consumed
G.	5.9	0	0	0	0		material melted and shrank—edge binding thread ignited, then self-extinguished

TABLE 12. 15 WASHINGS OF POLYESTER BLANKETS

Blanket Code	Vertical (Average of Three Tests)				4-Ply Horizontal		Full-Scale Match	Notes
	Burn Length	Flameout Time (second)	Flameout Drippings	Flameout Time (second)	Flameout Drippings			
B.	5.3	4.1	0	0	0	0	material shrank—holes formed—no flame propagation	
C.	5.2	3.2	0	0	0	0	material shrank—holes formed—no flame propagation	
D.	5.9	0	0	0	0	0	small amount of flame propagation—self-extinguished	
E.	4.5	2.1	2	68	11		blanket consumed approximately 90% consumed	
G.	5.4	0	0	0	0	0	minimal flame propagation—holes formed—self-extinguished	

APPENDIX A—RECOMMENDED PROCEDURE FOR THE 4-PLY HORIZONTAL FLAMMABILITY TEST FOR AIRCRAFT BLANKETS

Scope

This test method is intended for use in determining the resistance of blankets to flame when tested in the horizontal position and exposed to the Bunsen burner for 12 seconds.

Definitions

Ignition Time. Ignition time is the length of time the burner flame is applied to the specimen, 12 seconds for this test.

Flame Time. Flame time is the time in seconds that the specimen continues to flame after the burner flame is removed from beneath the specimen. Surface burning that results in a glow but not in a flame is not included.

Drip Flame Time. Drip flame time is the time in seconds that any flaming material continues to flame after falling from the specimen to the floor of the chamber. If no material falls from the specimen, the drip flame time is reported to be 0 seconds, and the notation "No Drip" is also reported. If there is more than one drip, the drip flame time reported is that of the longest flaming drip. If succeeding flaming drips reignite earlier drips that flamed, the drip flame time reported is the total of all flaming drips.

Test Apparatus

Test Cabinet. The test will be conducted in a draft-free cabinet fabricated in accordance with figures B-1, B-2, and B-3, or other equivalent enclosures acceptable to the FAA. A hole may be drilled into a wall to accommodate the test fixture. It is suggested that the cabinet be located inside an exhaust hood to facilitate clearing the cabinet of smoke after each test. Stainless steel or other corrosion resistant metal 0.040 inch (1 mm) thick should be used for the bottom surface of the chamber.

Test Fixture. The test fixture will be fabricated of corrosion resistant metal as shown in figure B-4, with its drawings in figure B-7. This is the same test fixture used for the forty-five-degree test specified in FAR 25.855.

Burner

The burner was a Bunsen or Tirrill type with a 3/8-inch (10-mm) inside diameter barrel and equipped with a needle valve located at the bottom of the burner barrel to adjust the gas flow rate and thereby adjust the flame height. There should also be a way to move the burner into and out of the test position when the cabinet door is closed.

Burner Fuel. Methane gas (99% minimum purity) or other burner fuel acceptable to the FAA should be used. Methane is the preferred fuel. It can be used without adding air through the aspirating holes at the bottom of the burner flame barrel; i.e., a pure diffusion flame.

Plumbing for Gas Supply. The necessary gas connections and the applicable plumbing were essentially those as shown in figure B-5. A control valve system with a delivery rate designed to furnish gas to the burner under pressure of $2\frac{1}{2} \pm \frac{1}{4}$ psi (17 ± 2 kPa) at the burner inlet was installed between the gas supply and the burner.

Flame Height Indicator. A removable height indicator was used to aid in setting the height of the flame. A suitable indicator has a prong extending 1.5 inches (38 mm) above the top of the burner barrel and spaced 1 inch (25 mm) away from the burner barrel as shown in figure B-5. If using methane as the burner fuel, it is desirable to have two prongs for measuring the flame height; one prong to indicate the height of the inner cone of the flame and one prong to indicate the height of the tip of the flame. For methane, it has been determined that when the height of the inner flame is 1 1/2 inches (38 mm) long, the proper flame profile is achieved.

Timer. A stopwatch or other device calibrated to the nearest 0.1 second was used to measure the time of application of the burner flame, the flame time, and the drip flame time.

Test Specimens

Specimen Selection. Specimens tested were cut from new aircraft blankets.

Specimen Number. At least three specimens should be prepared and tested.

Specimen Size. An 8- by 8-inch specimen is the exposed sample size; however, an 11- by 11-inch specimen should be cut in order to pull the specimen taut once secured in the test fixture. The excess material may be trimmed off.

Specimen Thickness. The specimen shall be of 4-ply configuration. This may be accomplished by folding the blanket in half and then folding it again or by stacking four individual blanket specimens cut to size.

Procedure

Burner Adjustment

- If using methane as the burner fuel, ensure that the air supply to the burner is shut off.
- Open the stopcock in the gas line fully and light the burner.
- Adjust the needle valve on the burner to give the proper 1 1/2-inch (38 mm) flame height and then remove the flame height indicator.

Test Procedure

- Insert the test fixture with specimen in place into the test cabinet. The bottom of the specimen should be 3/4 inch above the level at the top of the burner.
- Close the cabinet door and keep it closed during the test.
- The timer must be started immediately upon positioning the burner. Position the burner such that it is directly under the geometric center of the test specimen. This is shown in figure B-6.
- Apply the flame for 12 seconds and then withdraw it by moving the burner at least 3 inches (76 mm) away from the specimen or by turning the gas off. If the flame extinguishes during the ignition time for any reason, the test shall be rerun.
- If flaming material falls from the test specimen, determine the drip flame time for the specimen.
- Determine the flame time for the specimen.
- After all flaming ceases, the cabinet door should be opened slowly to clear the test cabinet of fumes and smoke. The exhaust fan may be turned on to facilitate clearing the smoke and fumes.
- Remove any material that fell from the specimen to the bottom of the cabinet. If necessary, clean the test cabinet window prior to testing the next specimen.

Report

Material Identification. Fully identify the material tested.

Test Results

Ignition Time. Report the ignition time was 12 seconds.

Flame Time. Report the flame time for each specimen tested. Determine and record the average value for flame time.

Drip Flame Time. Report the drip flame time for each specimen tested. Determine and record the average value for drip flame time. For specimens that have no drips, record "0" for the drip flame time and also record "No Drips."

Requirements

Flame Time. The average flame time for all of the specimens tested should not exceed 15 seconds.

Drip Flame Time. The average drip extinguishing time for all of the specimens tested should not exceed 5 seconds.

APPENDIX B—TEST SPECIMEN HOLDER CONSTRUCTION DRAWINGS

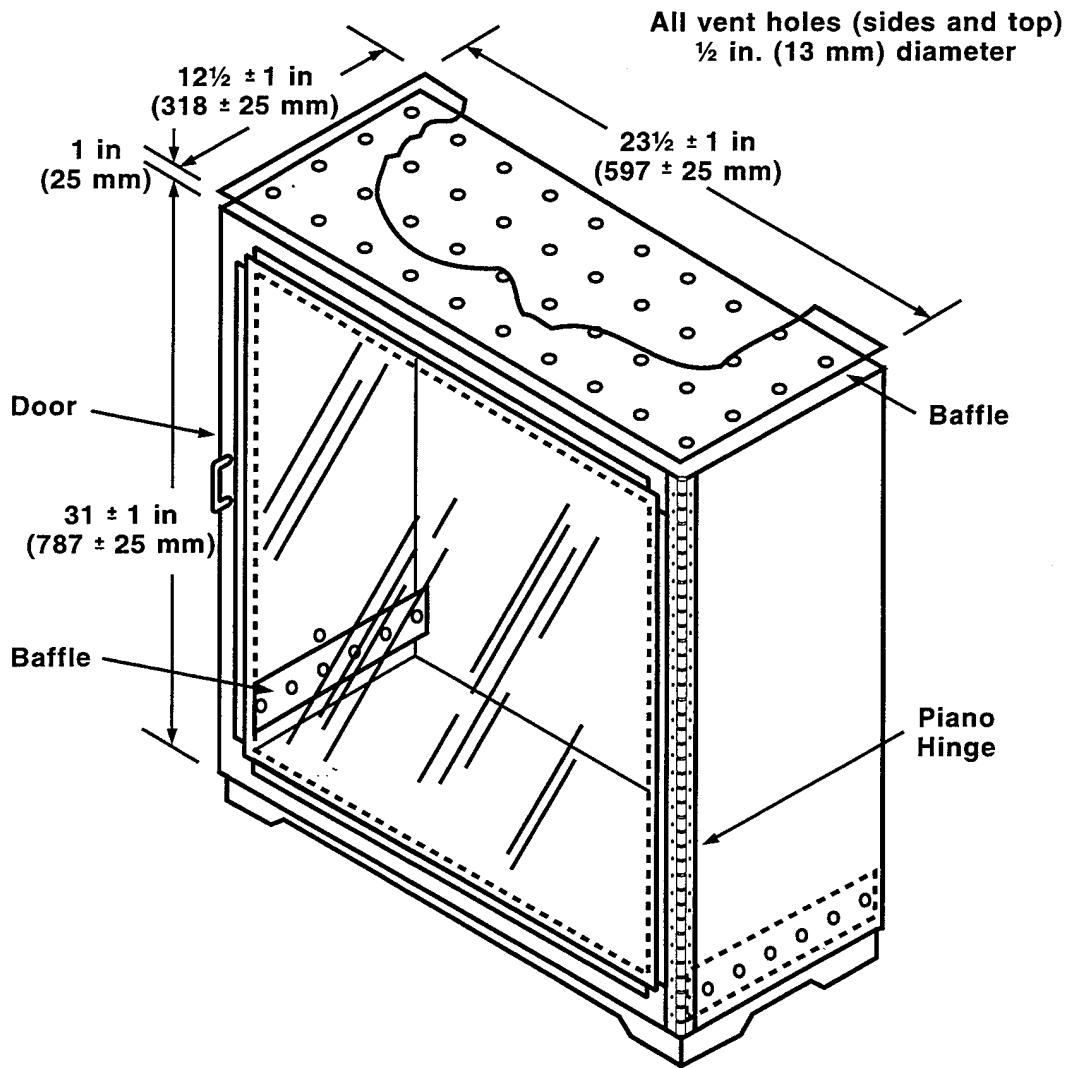
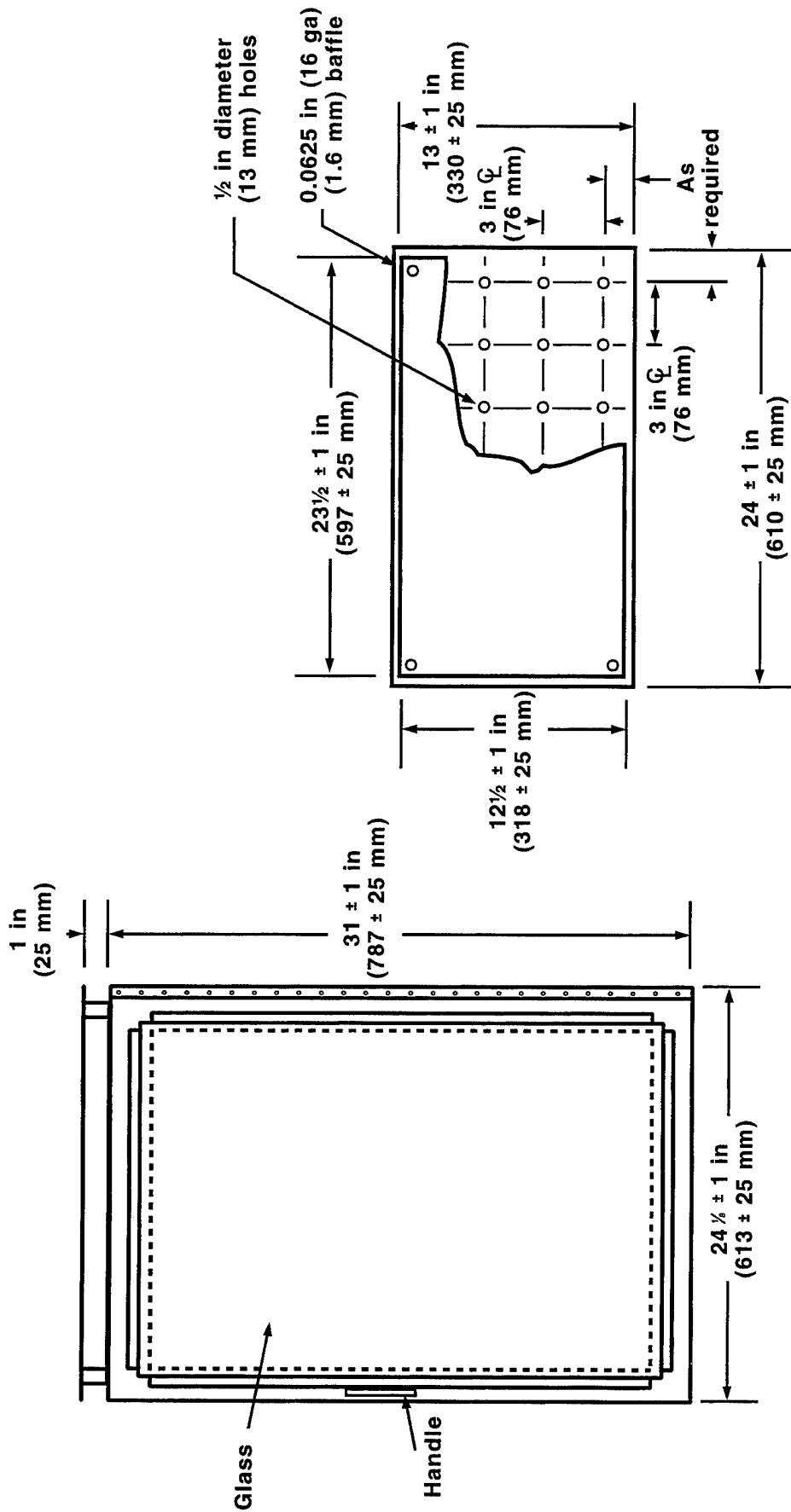

FIGURE B-1. SKETCH OF BUNSEN BURNER TEST CABINET



Top View Showing Holes and Baffle

FIGURE B-2. FRONT AND TOP VIEW OF BUNSEN BURNER TEST CABINET

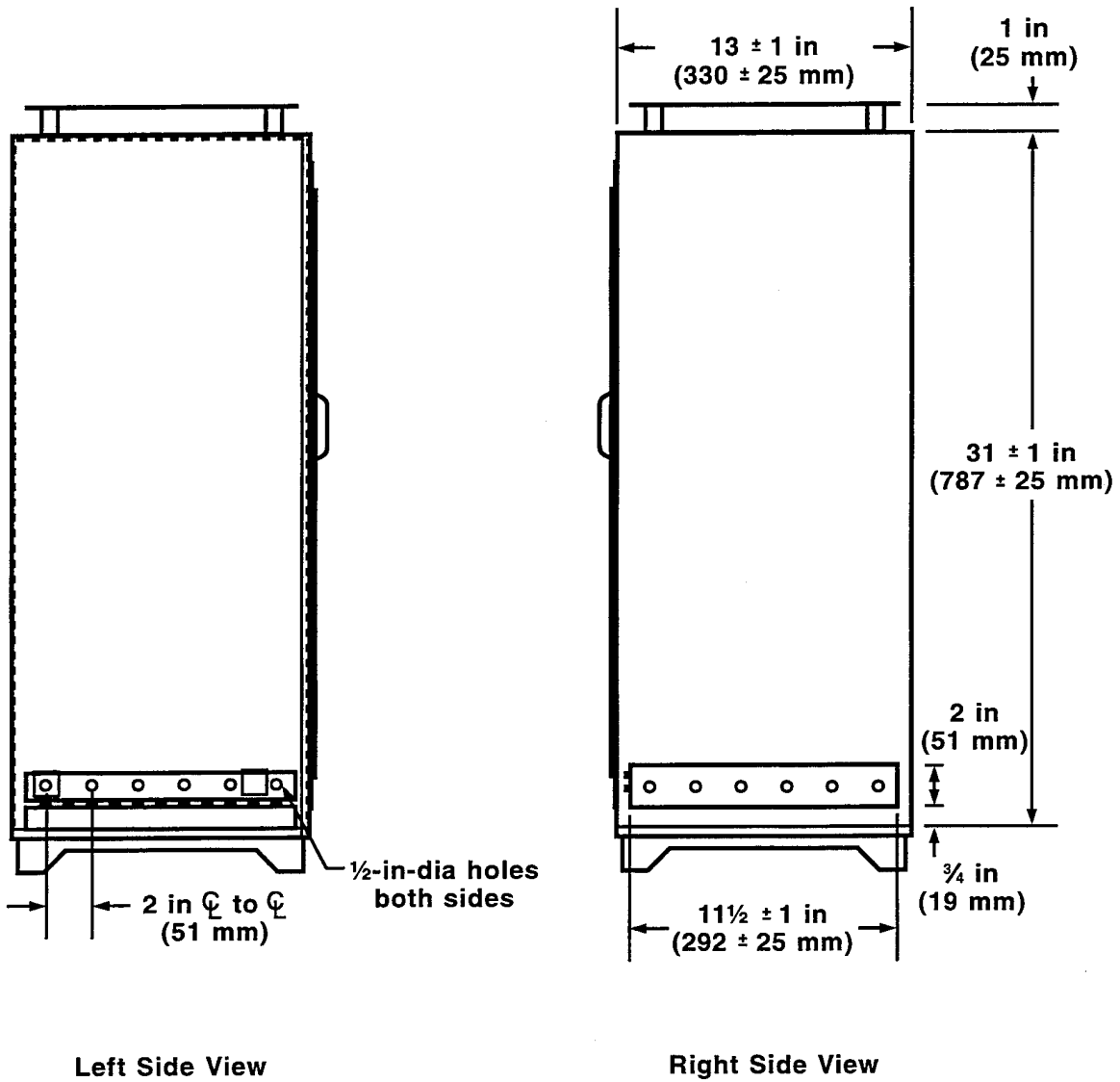

FIGURE B-3. SIDE VIEWS OF BUNSEN BURNER TEST CABINET

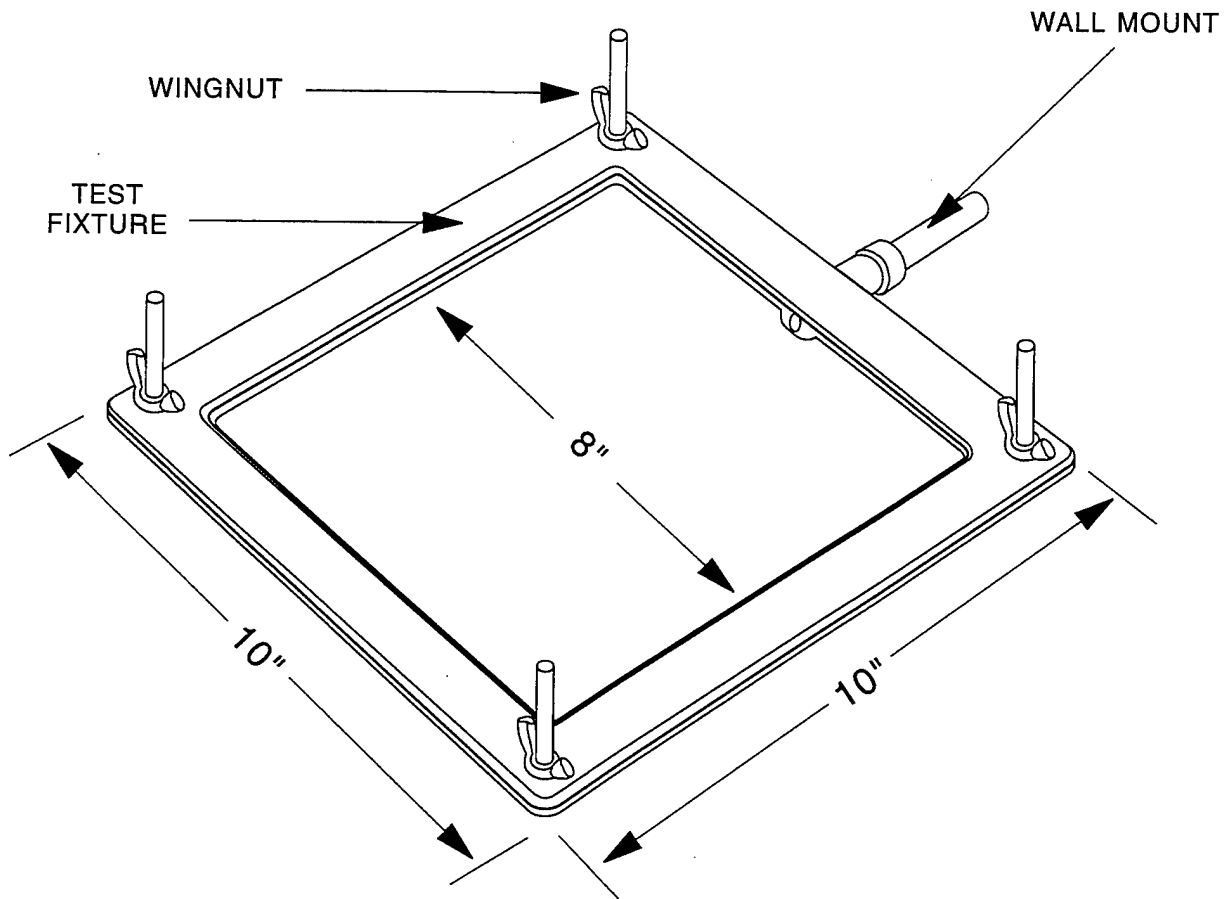

FIGURE B-4. HORIZONTAL TEST FIXTURE

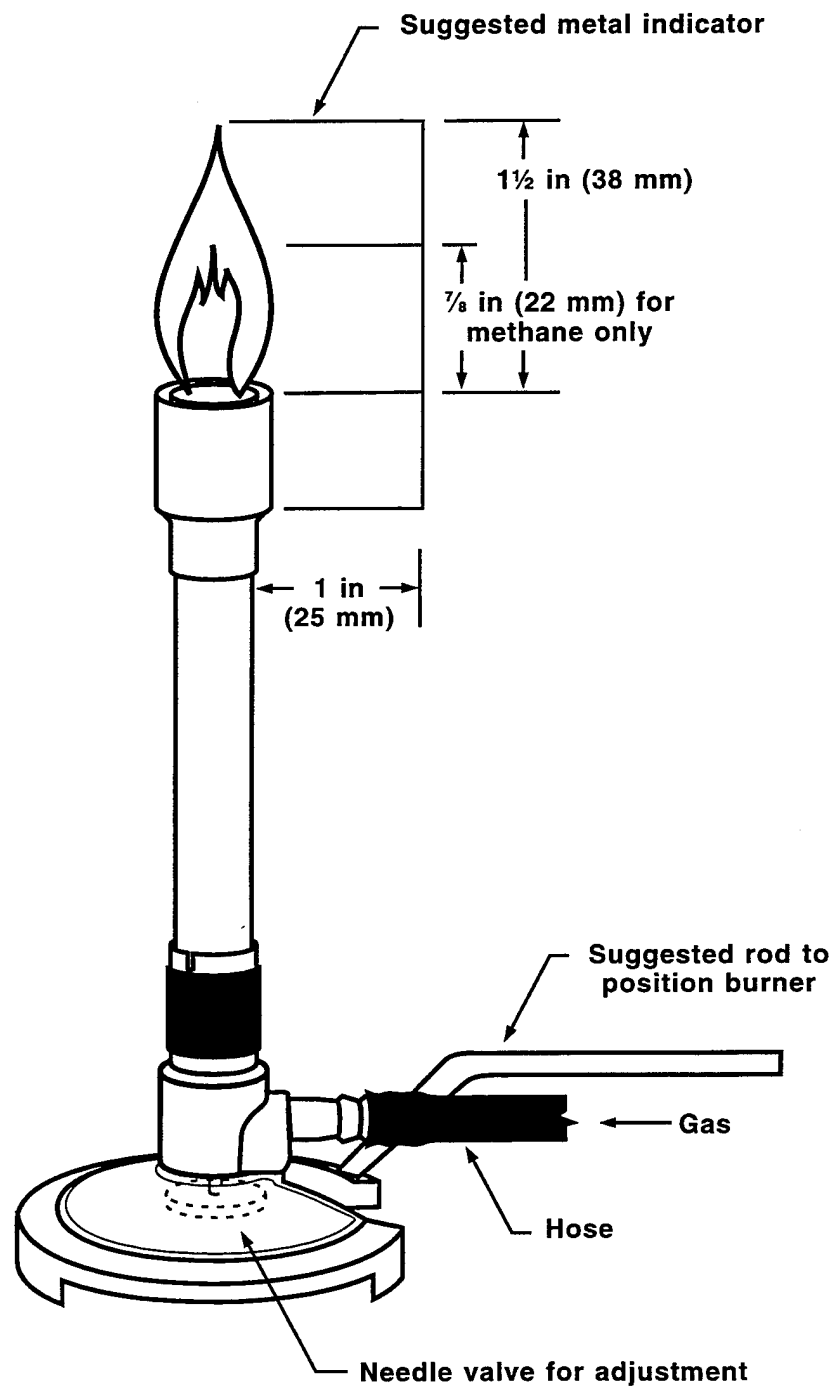

FIGURE B-5. BURNER PLUMBING AND BURNER FLAME HEIGHT INDICATOR

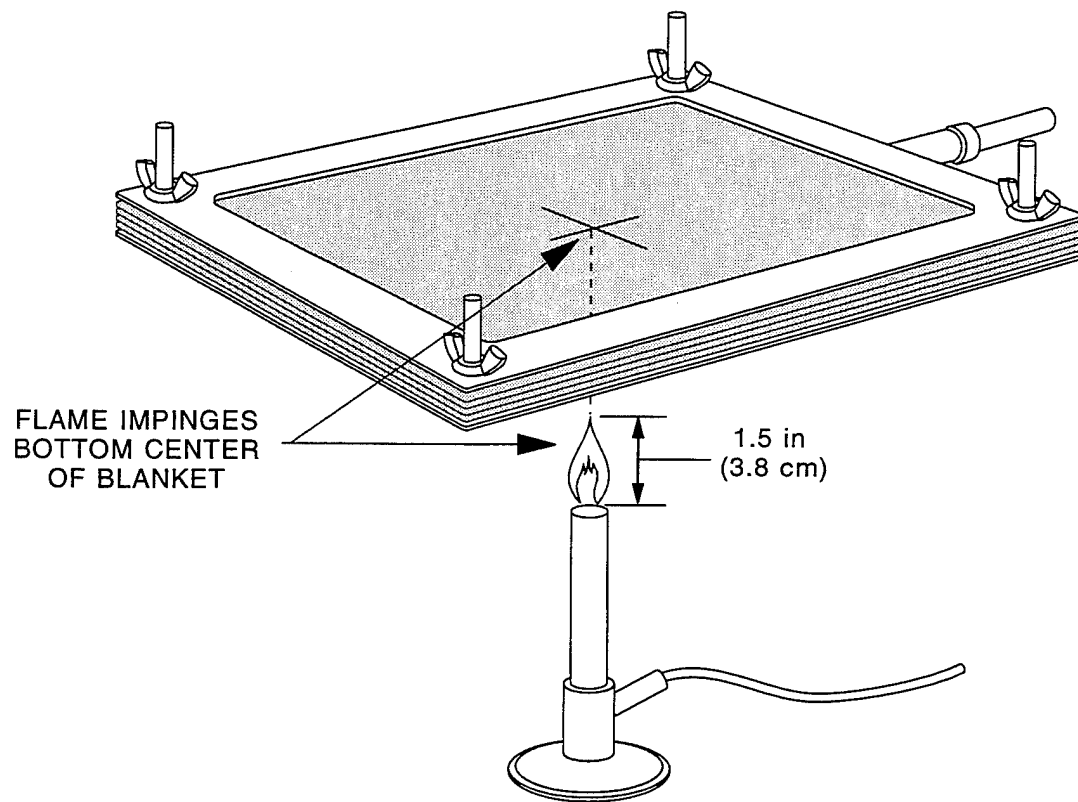
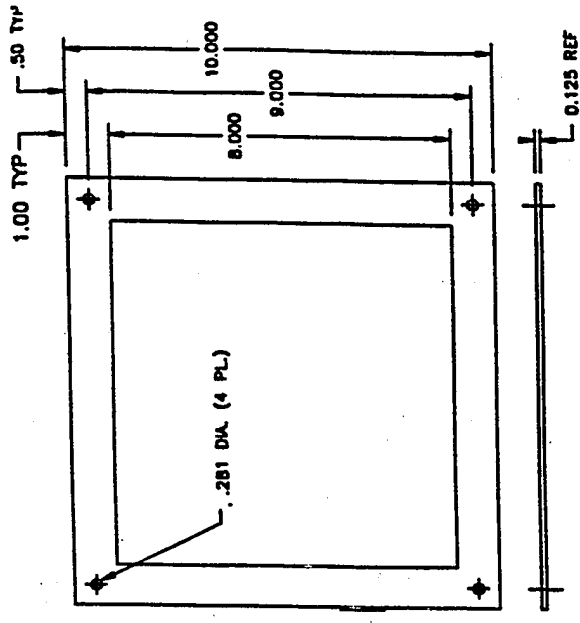
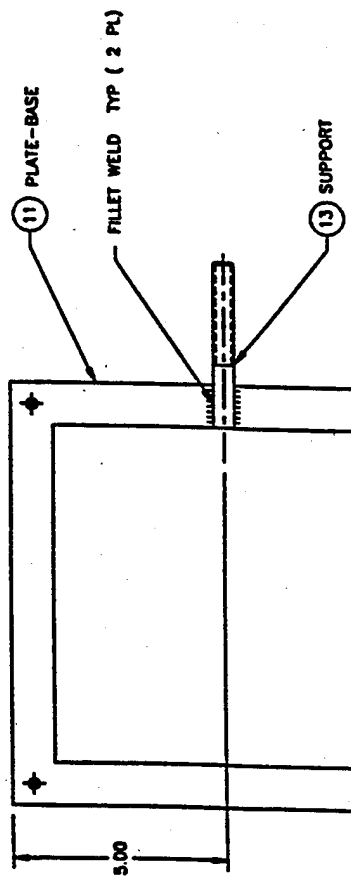

FIGURE B-6. HORIZONTAL TEST FIXTURE WITH 4-PLY BLANKET SAMPLE



2 PLATE-COVER

MATL: ALUMY. PL. .125 THICK
 QNTY: 1 REQ'D PER ASSY
 FINISH: VIBRATORY SAND & CAUSTIC DIP



11 PLATE-BASE

MATL: ALUMY. PL. .250 THICK
 QNTY: 1 REQ'D PER ASSY
 FINISH: VIBRATORY SAND & CAUSTIC DIP

13 SUPPORT

MATL: ALUMY. BAR .50 SQUARE
 QNTY: 1 REQ'D PER ASSY
 FINISH: VIBRATORY SAND & CAUSTIC DIP

1 PLATE ASS'Y

MAKE FROM PARTS NOTED
 QNTY: 1 REQ'D PER ASSY
 FINISH: VIBRATORY SAND & CAUSTIC DIP

TOLERANCES UNLESS NOTED	
1 PLACE	±.005
2 PLACE	±.010
3 PLACE	±.020
MILLIMETER	±.127

FIGURE B-7. TEST FIXTURE

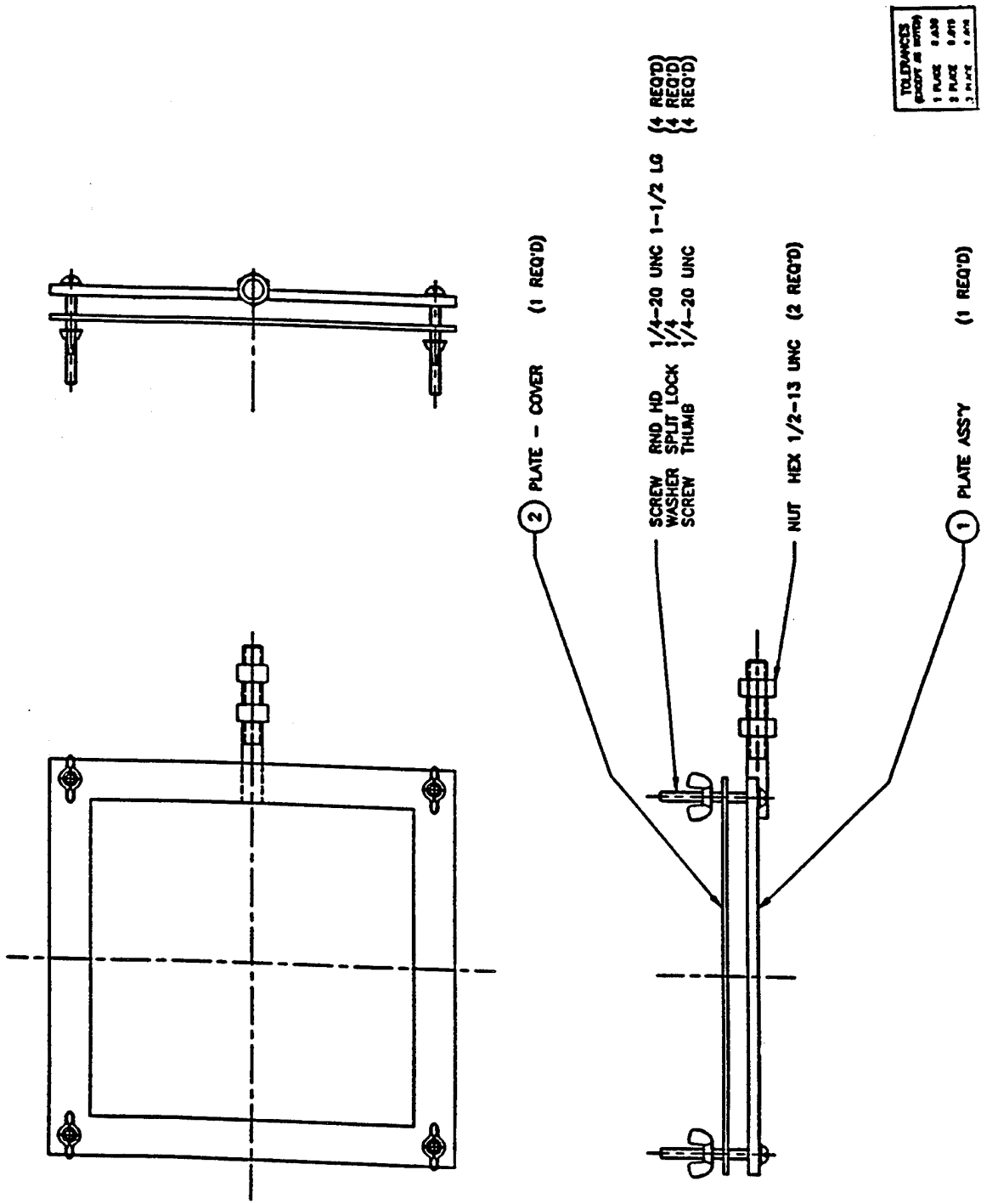

FIGURE B-7. TEST FIXTURE (CONTINUED)