

NASA TECHNICAL  
MEMORANDUM

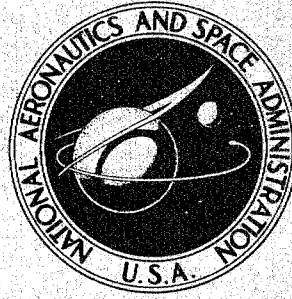

NASA TM X-1246

NASA TM X-1246

DISTRIBUTION STATEMENT A  
Approved for public release;  
Distribution Unlimited

19960419 039

SHEAR MODULI OF BORON FILAMENTS

*by Harvey W. Herring and V. Gopala Krishna*

*Langley Research Center*

*Langley Station, Hampton, Va.*

NATIONAL AERONAUTICS AND SPACE ADMINISTRATION • WASHINGTON, D. C. • JULY

DEPARTMENT OF DEFENSE  
PLASTICS TECHNICAL EVALUATION CENTER  
CAMP BELLEROS, WRIGHT PATTISON AIR FORCE BASE, DOVER, N. J.

*D*  
PLASTIC 8896

NASA TM X-1246

**SHEAR MODULI OF BORON FILAMENTS**

By Harvey W. Herring and V. Gopala Krishna

Langley Research Center  
Langley Station, Hampton, Va.

USING QUALITY INSPECTED P

**NATIONAL AERONAUTICS AND SPACE ADMINISTRATION**

---

For sale by the Clearinghouse for Federal Scientific and Technical Information  
Springfield, Virginia 22151 - Price \$1.00

## SHEAR MODULI OF BORON FILAMENTS

By Harvey W. Herring and V. Gopala Krishna  
Langley Research Center

### SUMMARY

The shear moduli of boron filaments were determined by a dynamic torsion-pendulum method and a static torque-twist method. A detailed description of the equipment and techniques involved in the two experimental methods is included. Similar vapor deposition processes were used by two different manufacturers to produce the boron filaments used in the study. Overall diameters of the filaments ranged from 0.0017 to 0.0030 inch (43 to 76  $\mu\text{m}$ ) and the average shear modulus ranged from about  $16 \times 10^3$  to  $20 \times 10^3$  ksi (110 to 138  $\text{GN}/\text{m}^2$ ).

### INTRODUCTION

Boron filaments have recently become of interest for reinforcement in certain composite-structure applications in which increased stiffness is required. These filaments are made by a continuous vapor deposition process in which boron from the hydrogen reduction of a boron halide compound is deposited onto the surface of a 0.0005-inch-diameter (13  $\mu\text{m}$ ) incandescent tungsten substrate wire. The resultant filament may have a diameter of about 0.001 inch (25  $\mu\text{m}$ ) or more and usually contains a 0.0006-to-0.0007-inch-diameter (15 to 18  $\mu\text{m}$ ) core of tungsten borides which is formed during manufacture as a result of the elevated temperature. The tensile strengths and tensile elastic moduli of several representative types of boron filament are reported in reference 1.

The present paper presents the results of a study of the shear moduli of several boron filaments by two independent methods: dynamic torsion pendulum and static torque twist. A knowledge of the shear modulus is necessary to characterize a particular material completely and may be useful in calculations involved in structural design work. In the case of the torsion-pendulum method, the effects of variations in filament length, tensile stress, and oscillatory amplitude were investigated. A limited number of tests were performed with 0.0050-inch-diameter (127  $\mu\text{m}$ ) beryllium wire to provide a basis for comparison. Beryllium wire, like boron, is characterized by low density and a high value of Young's modulus. The validity of the test techniques was established by using 0.0040-inch-diameter (102  $\mu\text{m}$ ) steel wire, a material for which the shear modulus is well known.

The units used for the physical quantities defined in this paper are given in both U.S. Customary Units and the International System of Units (SI) (ref. 2). The appendix presents factors relating these two systems of units.

### SYMBOLS

$c_2$	viscous damping coefficient associated with oscillation of torsion pendulum, rad/s
$E$	Young's modulus of elasticity, ksi (GN/m <sup>2</sup> )
$G$	shear modulus of elasticity, ksi (GN/m <sup>2</sup> )
$I$	moment of inertia of cantilever rod cross section, in <sup>4</sup> (cm <sup>4</sup> )
$I_{xx}$	mass moment of inertia of pendulum bob, slug-ft <sup>2</sup> (kg-m <sup>2</sup> )
$J$	polar moment of inertia of filament specimen, in <sup>4</sup> (cm <sup>4</sup> )
$L$	length of filament specimen, in. (cm)
$l$	length of cantilever rod, in. (cm)
$P_A, P_B$	coupling forces, lbf (N)
$s$	distance between cantilever rods, in. (cm)
$T$	torque, in-lbf (m-N)
$\delta_A, \delta_B$	deflections of cantilever rods, in. (cm)
$\theta$	twist angle, rad
$\sigma$	tensile stress, ksi (MN/m <sup>2</sup> )
$\tau$	period of oscillation of torsion pendulum, s
$\Omega$	damped angular frequency of torsion pendulum, rad/s
$\omega$	natural angular frequency of torsion pendulum, rad/s

## TEST SPECIMENS

The boron filaments tested were produced by two different manufacturers (table I) and were produced in continuous lengths by a vapor deposition process involving the reduction of  $BCl_3$  vapor (ref. 1). The filaments contained tungsten boride cores approximately 0.006 inch ( $15 \mu m$ ) in diameter. Filament A from one manufacturer was 0.0017 inch ( $43 \mu m$ ) in diameter. Filaments B and C were two separate lots of filament produced by the other manufacturer; each was 0.0030 inch ( $76 \mu m$ ) in diameter.

## TEST METHODS

Two independent test methods were used in this investigation to determine the shear moduli of boron filaments. One, a dynamic method, embodies the classical torsion pendulum normally used to determine moments of inertia of irregularly shaped masses. The other is the more familiar static torque-twist method.

### Torsion-Pendulum Method

The torsion pendulum used in this investigation is shown in figures 1 and 2. Filament specimens were suspended from a fixture attached to the top of a transparent plastic enclosure (fig. 1). The enclosure served to shield the pendulum from air currents. Attached to the bottom end of the specimen was a bob consisting of a rectangular steel beam to which a plane mirror was affixed. A small steel rod was bonded to the underside of the beam and extended downward into a container of oil to damp the linear oscillation of the pendulum. Rotary

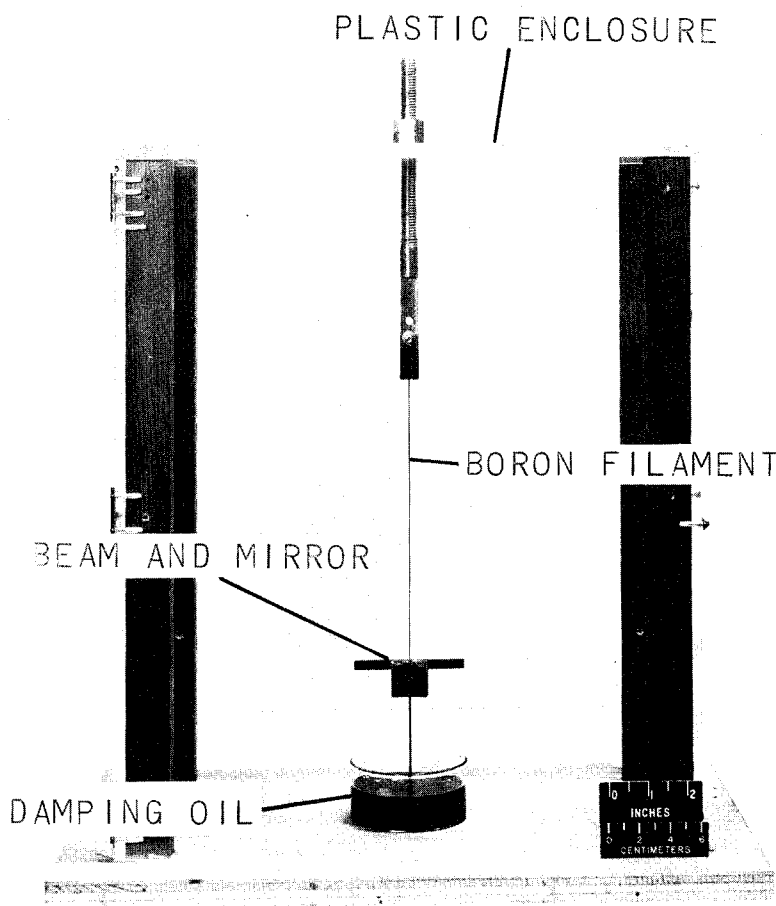

L-66-1134

Figure 1.- Torsion pendulum used in obtaining shear moduli of filaments.

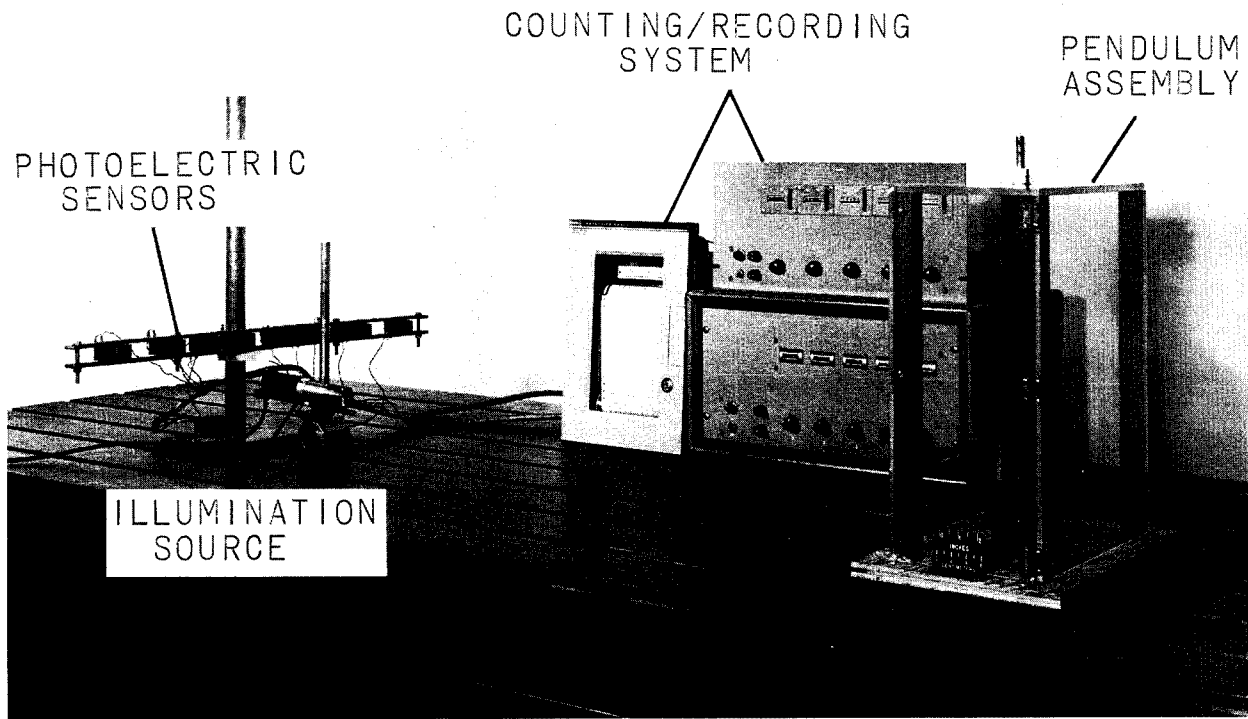

L-66-1135

Figure 2.- Apparatus used to obtain filament shear modulus by the torsion-pendulum method.

oscillation of the pendulum was initiated magnetically, and a high-intensity beam of light from an external source was reflected by the mirror across a series of photoelectric sensors spaced at measured intervals along a straight line (fig. 2). This bank of sensors was separated a known distance from the pendulum. Each time the reflected light beam traversed a photoelectric cell, a count was registered on a dial counter and recorded on a strip chart which progressed at a predetermined speed. Corrections were applied to compensate for refraction of the reflected light beam by the plastic shield.

The torsion pendulum is considered to be a system of damped free vibration with one degree of freedom subject to only viscous external damping, and its motion is described mathematically in the following discussion (see also refs. 3 and 4).

The damped frequency of oscillation of the pendulum  $\Omega$  may be determined by first measuring the period  $\tau$ , and then solving the relation

$$\Omega = 2\pi/\tau$$

The damped frequency is related to the natural frequency  $\omega$  by the expression

$$\Omega = \omega^2 - c_2^2$$

where  $c_2$  is a damping coefficient which may be experimentally determined by first counting the number of oscillations necessary for a specified decay in amplitude and then solving the equation

$$c_2 = (\ln \theta_n - \ln \theta_{n+y}) / y\tau$$

where  $\theta_n$  is the amplitude of the pendulum in its  $n$ th oscillation, and  $\theta_{n+y}$  is the amplitude  $y$  cycles later.

The natural frequency of oscillation may then be calculated. It is related to the filament shear modulus  $G$  by the fundamental relationship

$$G = \omega^2 I_{xx} L / J$$

where  $I_{xx}$  is the mass moment of inertia of the pendulum bob,  $L$  is the length of the filament specimen sustaining the bob, and  $J$  is the polar moment of inertia of the filament.

#### Static Torque-Twist Method

The apparatus (fig. 3) used for determining shear modulus by the torque-twist method involves the indirect measurement of the restoring torque in a twisted filament specimen. The filament to be tested is again suspended from the top of the transparent plastic enclosure. The pendulum bob is fabricated so that it has two radial arms (fig. 4) which extend outward to make contact with the upper ends of two 0.033-inch-diameter (840  $\mu\text{m}$ ) steel rods attached to a rigid base to form cantilevers. When the filament specimen is twisted an angle  $\theta$  and maintained at that angle by means of the cantilever rods, the restoring torque results in the application of two coupling forces to the free ends of the cantilever rods. The resulting deflections are measured with two filar microscopes, which have been calibrated with a stage micrometer, and are accurate to within 0.0001 inch (2.5  $\mu\text{m}$ ). The coupling forces can then be calculated from the equations

$$P_A = 3\delta_A EI / l^3$$

$$P_B = 3\delta_B EI / l^3$$

where  $P_A$  and  $P_B$  are the coupling forces,  $\delta_A$  and  $\delta_B$  are the cantilever deflections,  $E$  is Young's modulus of steel,  $I$  is the moment of inertia of the cantilever cross section, and  $l$  is the cantilever length. The restoring torque  $T$  is then given by

$$T = \frac{S}{2} (P_A + P_B)$$

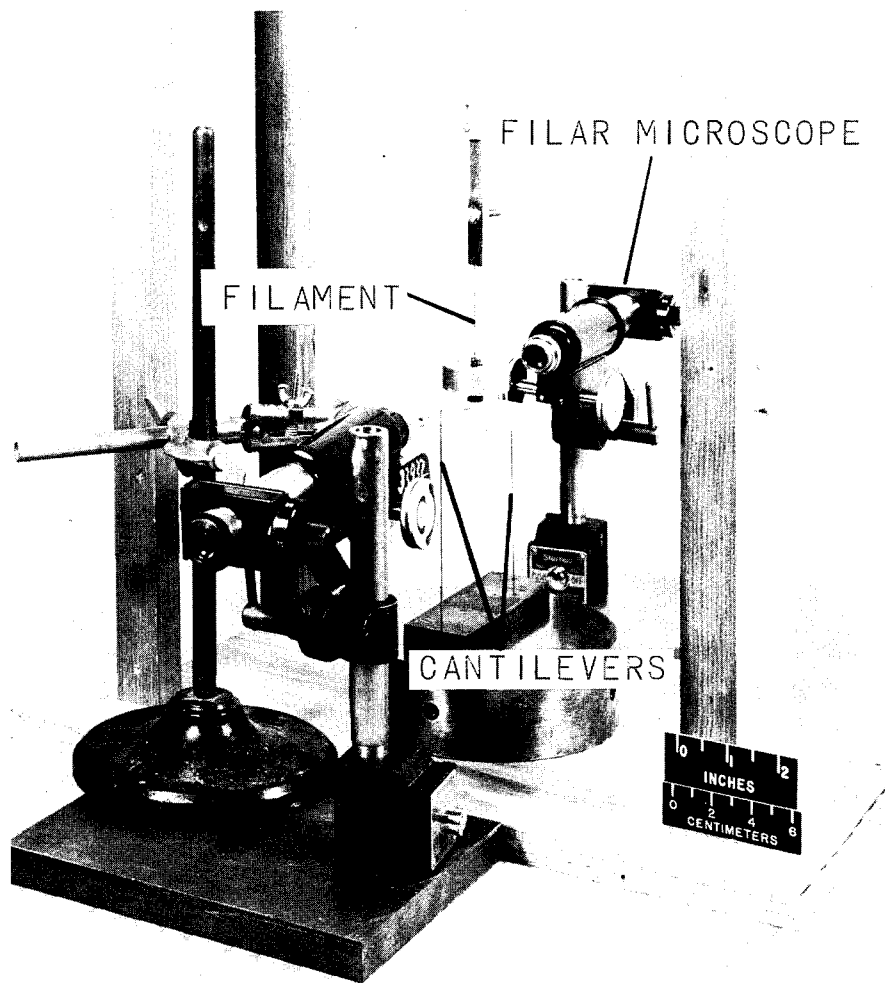

L-66-1136  
 Figure 3.- Torque-twist apparatus for determination of filament shear modulus.

where  $s$  is the distance between the two cantilever rods. The shear modulus  $G$  may then be calculated by using the familiar torque-twist relationship

$$G = TL/J\theta$$

where  $L$  is the length of the filament specimen, and  $\theta$  is the angle of twist.

### RESULTS AND DISCUSSION

Average values of shear modulus for the various boron filaments tested ranged from about  $16 \times 10^3$  to  $20 \times 10^3$  ksi ( $110$  to  $138$  GN/m<sup>2</sup>) and are listed in table II. These values are based on 20 tests each of 5-inch-long (12.7 cm) specimens in the torsion pendulum,

and 20 tests of 2-inch-long (5.1 cm) specimens in the torque-twist apparatus. A small number of torsion-pendulum tests were performed by using 0.005-inch-diameter ( $127 \mu\text{m}$ ) beryllium wire to provide a basis for comparison. Beryllium wire is similar to boron filament in that it is characterized by low density and a high Young's modulus. The validity of the test techniques was established by using 0.004-inch-diameter ( $102 \mu\text{m}$ ) steel wire. The value of shear modulus determined for beryllium wire was  $18.0 \times 10^3 \text{ ksi}$  ( $124 \text{ GN/m}^2$ ). This number is comparable with the value  $20 \times 10^3 \text{ ksi}$  ( $138 \text{ GN/m}^2$ ) given in reference 5 for beryllium bar and sheet stock. The shear modulus obtained for steel wire was  $11.8 \times 10^3 \text{ ksi}$  ( $81.4 \text{ GN/m}^2$ ) which is in agreement with the handbook value for steel.

The results of torque-twist tests of three different lengths of type C filament specimens are presented in figure 5 as a torque-twist curve. The solid line shows a linear relationship between torque and twist for a shear modulus of  $17.7 \times 10^3 \text{ ksi}$  ( $122 \text{ GN/m}^2$ ) – a value which is in excellent agreement with the shear modulus obtained from the torsion pendulum (table II).

When specimen length and oscillatory amplitude were varied in the torsion-pendulum method, the value of shear modulus obtained remained essentially constant. The effect of

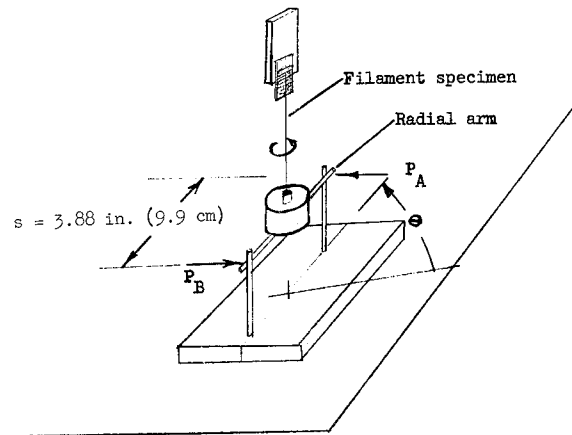

(a) Schematic of torque-twist apparatus.

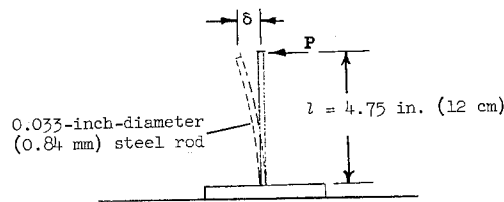

(b) Cantilever construction.

Figure 4.- Details of pendulum bob and cantilever arrangement in apparatus used to obtain shear moduli of filaments by static torque-twist method.

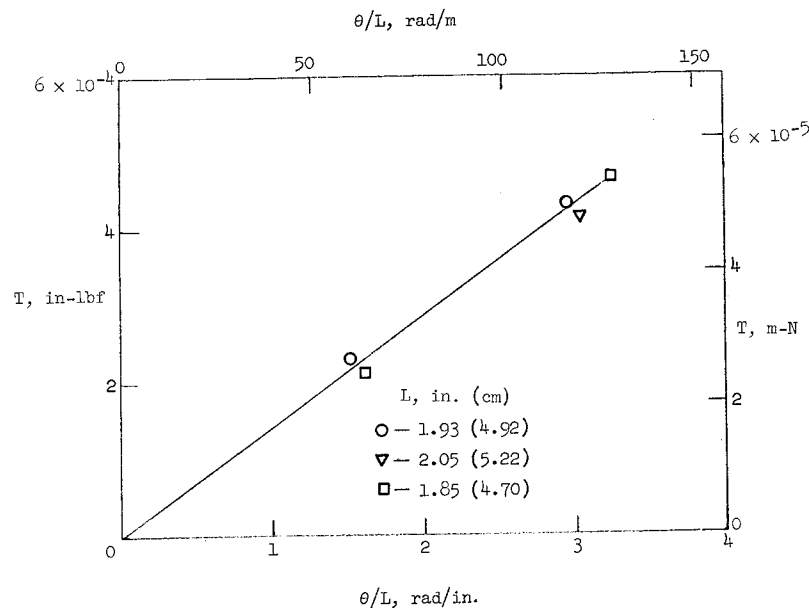

Figure 5.- Torque-twist curve for type C boron filament of 0.0030-in. ( $76 \mu\text{m}$ ) diameter.

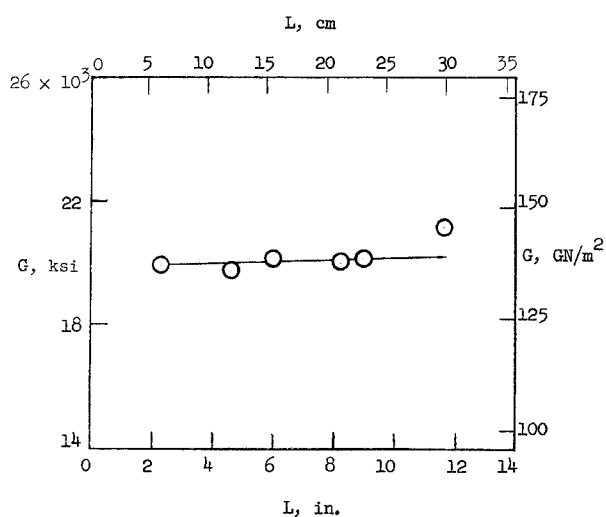

Figure 6.- Effect of specimen length on shear modulus of type A filament from torsion-pendulum tests.

specimen length on the shear modulus of filament A is shown in figure 6. When length was varied in tests of six separate specimens, shear modulus varied only slightly from a value of about  $20 \times 10^3$  ksi ( $138 \text{ GN/m}^2$ ). Figure 7 shows the effect of variation in oscillatory amplitude on the shear modulus of filament B. Each point shown is an average of two tests of separate specimens. Over a range of  $60^\circ$  ( $\frac{\pi}{3}$  rad), a twofold variation in  $\theta$ , there was no significant change in shear modulus.

The effect of varying the torsion-pendulum weights, and consequently, the tensile stress of the filament is shown in

figures 8 and 9 for filaments B and C. The tensile stress was varied up to 140 ksi ( $965 \text{ MN/m}^2$ ) and had no effect on shear modulus, except that, in both curves shear modulus decreases sharply as tensile stress is reduced below 18 ksi ( $106 \text{ MN/m}^2$ ). The reason for this decrease is probably that the lower stresses are not sufficient to remove the curvature which exists in the filament as a result of its manufacture and packaging.

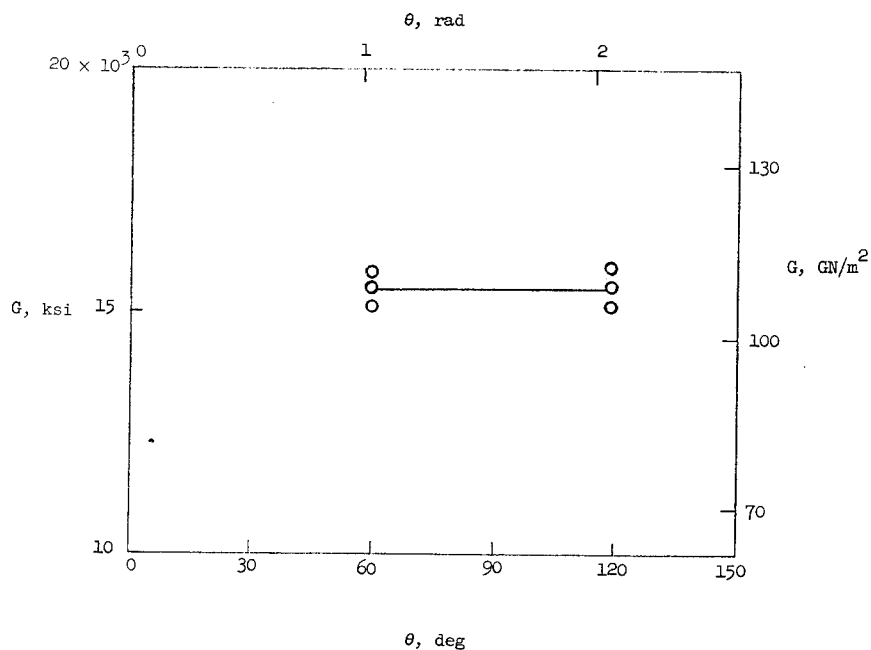

Figure 7.- Effect of oscillatory amplitude on shear modulus of filament B from torsion-pendulum tests.

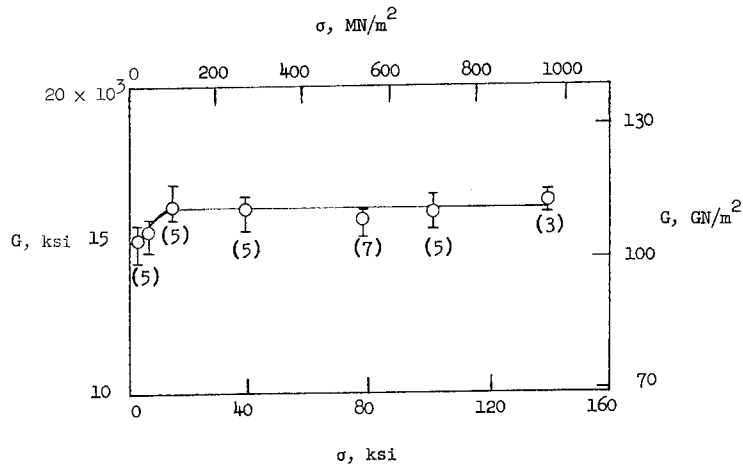

Figure 8.- Effect of tensile stress on shear modulus of type B filaments from torsion-pendulum tests. Numbers in parentheses represent number of tests conducted.

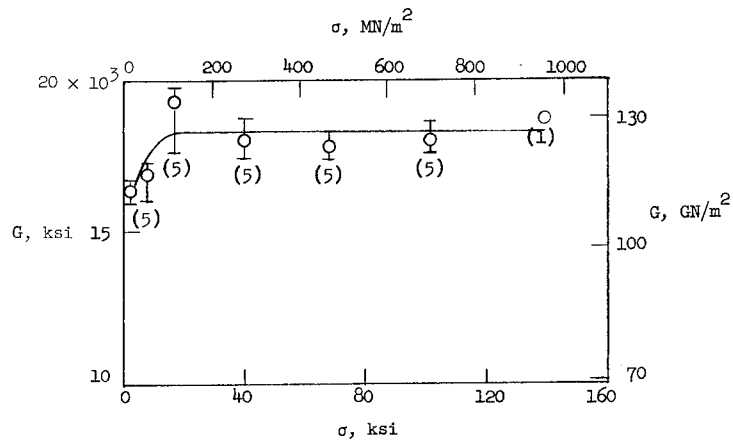

Figure 9.- Effect of tensile stress on shear modulus of type C filaments from torsion-pendulum tests. Numbers in parentheses represent number of tests conducted.

## CONCLUDING REMARKS

The results of a brief investigation to determine the shear moduli of boron filaments by independent torsion-pendulum and torque-twist methods are presented. For boron filaments produced by two different manufacturers, the average shear modulus ranged from about  $16 \times 10^3$  to  $20 \times 10^3$  ksi (110 to 138 GN/m<sup>2</sup>). In tests utilizing the torsion pendulum, specimen length and oscillatory amplitude were varied with no discernible effect on filament shear modulus. The effect of varying torsion-pendulum weights, and consequently, filament tensile stress was also studied. Variations in specimen tensile stress up to 140 ksi (965 MN/m<sup>2</sup>) during testing had no significant effect on shear modulus provided the stress was great enough to keep the filament straight along its length.

Langley Research Center,  
National Aeronautics and Space Administration,  
Langley Station, Hampton, Va., March 29, 1966.

## APPENDIX

### Conversion of U.S. Customary Units to SI Units

The International System of Units (SI) was adopted by the Eleventh General Conference on Weights and Measures, Paris, October 1960, in resolution No. 12 (ref. 2). Conversion factors for the units used herein are given in the following table:

Physical quantity	U.S. Customary Unit	Conversion factor (*)	SI Unit
Angle	deg	$1.745329 \times 10^{-2}$	radians (rad)
Length	in.	0.0254	meters (m)
Stress	ksi = 1000 lbf/in <sup>2</sup>	$6.895 \times 10^6$	newtons per sq meter (N/m <sup>2</sup> )
Torque	in-lbf	0.113	meter-newtons (m-N)

\*Multiply value given in U.S. Customary Unit by conversion factor to obtain equivalent value in SI Unit.

Prefixes to indicate multiple of units are as follows:

Prefix	Multiple
micro ( $\mu$ )	$10^{-6}$
milli (m)	$10^{-3}$
centi (c)	$10^{-2}$
mega (M)	$10^6$
giga (G)	$10^9$

## REFERENCES

1. Herring, Harvey W.: Selected Mechanical and Physical Properties of Boron Filaments. NASA TN D-3202, 1966.
2. Mechtly, E. A.: The International System of Units – Physical Constants and Conversion Factors. NASA SP-7012, 1964.
3. Pletta, Dan H.: Engineering Statics and Dynamics. The Ronald Press Co., c.1951.
4. Timoshenko, S.; and Young, D. H.: Vibration Problems in Engineering. Third ed., D. Van Nostrand Co., Inc., c.1955.
5. Crawford, Robert F.; and Burns, A. Bruce: Strength, Efficiency, and Design Data for Beryllium Structures. ASD Tech. Rept. 61-692, U.S. Air Force, 1962.

TABLE I.- MANUFACTURERS OF BORON FILAMENTS  
USED IN THIS STUDY

Filament	Manufacturer
A	United Aircraft Corp. East Hartford, Connecticut
B, C	Texaco Experiment, Inc. Richmond, Virginia

TABLE II.- SHEAR MODULUS OF BORON FILAMENTS\*

Filament	Diameter		Shear modulus for --			
	in.	$\mu\text{m}$	Torsion pendulum method		Torque twist method	
			ksi	$\text{GN}/\text{m}^2$	ksi	$\text{GN}/\text{m}^2$
A	$1.7 \times 10^{-3}$	43	$20.2 \times 10^3$	140	-----	---
B	3.0	76	15.8	109	-----	---
C	3.0	76	18.0	124	$17.7 \times 10^3$	122

\*Each shear modulus value tabulated is an average of 20 tests of separate filament specimens.