

N

NASA TECHNICAL NOTE



NASA TN D-3392

NASA TN D-3392

REPRODUCTION OF THIS DOCUMENT IS UNLIMITED  
EXCEPT WHERE SHOWN OTHERWISE  
IN THE FOOTNOTES TO THIS DOCUMENT

19960419 041

# COMPATIBILITY OF POLYMERIC MATERIALS WITH FLUORINE AND FLUORINE-OXYGEN MIXTURES

*by Louis M. Russell, Harold W. Schmidt, and Larry H. Gordon*  
*Lewis Research Center*  
*Cleveland, Ohio*

DTIC QUALITY INSPECTED 1

NATIONAL AERONAUTICS AND SPACE ADMINISTRATION • WASHINGTON, D. C. • JUNE 1966

8877  
2018

# DISCLAIMER NOTICE

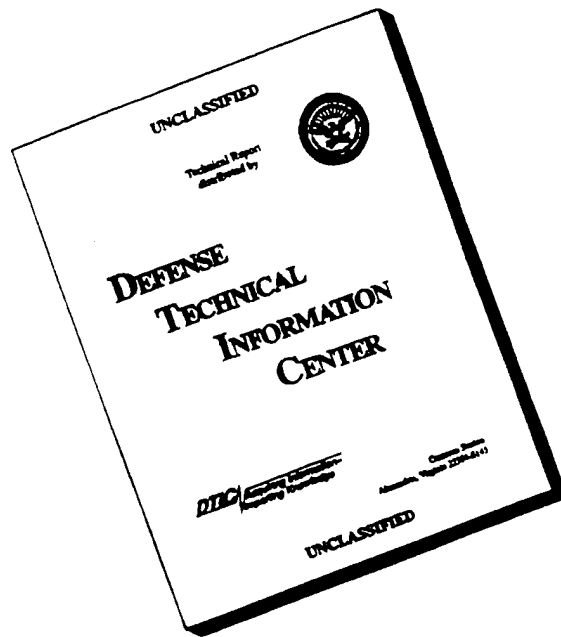

**THIS DOCUMENT IS BEST QUALITY AVAILABLE. THE COPY FURNISHED TO DTIC CONTAINED A SIGNIFICANT NUMBER OF PAGES WHICH DO NOT REPRODUCE LEGIBLY.**

NASA TN D-3392

COMPATIBILITY OF POLYMERIC MATERIALS WITH FLUORINE  
AND FLUORINE-OXYGEN MIXTURES

by Louis M. Russell, Harold W. Schmidt, and Larry H. Gordon

Lewis Research Center  
Cleveland, Ohio

NATIONAL AERONAUTICS AND SPACE ADMINISTRATION

---

For sale by the Clearinghouse for Federal Scientific and Technical Information  
Springfield, Virginia 22151 - Price \$2.00

COMPATIBILITY OF POLYMERIC MATERIALS WITH FLUORINE  
AND FLUORINE-OXYGEN MIXTURES

by Louis M. Russell, Harold W. Schmidt, and Larry H. Gordon

Lewis Research Center

SUMMARY

Compatibility tests were performed on a number of polymeric materials with the use of various mixtures of fluorine and oxygen in both gaseous and liquid states. The purpose of these tests was to investigate the feasibility of using fluorine-oxygen mixtures in rocket-propulsion systems containing some nonmetallic materials. The tests were divided into two major areas, static tests and dynamic tests.

In the static tests, a number of test samples were exposed to various FLOX (fluorine-oxygen) mixtures, both gaseous and liquid, at atmospheric pressure and virtually static conditions in order to obtain information on compatibility solely as a function of fluorine concentration. The results of these tests are given in bar-graph form. The reactivity of the materials tested with FLOX under static conditions is a function of the concentration of fluorine in the mixture.

In the dynamic tests, selected materials were exposed to fluorine and FLOX at various combinations of concentration and flow velocity. Reactivity profiles were generated for these materials as functions of these two parameters. These graphs show the areas of compatibility and noncompatibility of selected materials in a dynamic fluorine or FLOX environment. At any given fluorine concentration, flow velocity was a strongly significant parameter in the reactivity of FLOX with all materials tested. Generally the fluorocarbon polymers, particularly the fully fluorinated, straight-chain polymers were the most compatible with fluorine and with FLOX.

In both static and dynamic tests, a comparison between cryogenic liquid and ambient-temperature gaseous test results indicated that the liquid was the more reactive.

It was concluded that some of the materials tested may be considered for use in rocket systems with fluorine or FLOX under controlled conditions of exposure; however, because of possible variations in quality and because polymers are more sensitive to contamination than metals in a fluorine environment, they should be used with a margin of safety.

## INTRODUCTION

Fluorine is one of the highest energy oxidizers possible for chemical rocket propulsion. The use of fluorine as a rocket oxidizer or as an additive to liquid oxygen in present rocket propulsion systems would provide a significant increase in payload capability for many missions. The reactivity or compatibility of nonmetallic materials with fluorine and fluorine-oxygen mixtures (FLOX) has not been specifically determined, and it is generally recognized that some nonmetallic materials, particularly some polymers, are desirable for use as gaskets and seals in rocket oxidizer systems. Therefore, before the use of fluorine or FLOX was considered, particularly in existing rocket systems, an investigation was required to determine the compatibility of various polymeric materials that could be considered for use in a fluorine or a FLOX environment.

In order to determine the limits of FLOX compatibility, tests were made under static and dynamic conditions with both liquid and gaseous FLOX. In static tests, samples were exposed to increasing fluorine concentrations until either reaction occurred or the 100 percent fluorine level was reached. In dynamic tests, the nonmetallic materials were fabricated into orifice configurations and exposed to increasing fluorine concentrations and flow velocities. These tests gave information on reactivity of FLOX with various polymers as functions of the aforementioned parameters. The information included herein should be helpful in the selection and application of polymeric materials in fluorine or fluorine-oxygen environments. Tests were also performed to verify the miscibility of liquid fluorine with liquid oxygen. The results of these tests are discussed in appendix A.

## APPARATUS AND PROCEDURE

### STATIC FLOX TESTS

#### Apparatus

A schematic diagram of the test apparatus, located at the Lewis Research Center, used in the static tests is shown in figure 1. In liquid FLOX testing, the test chamber was a graduated glass cylinder in which fluorine and oxygen gas were condensed. A liquid-nitrogen Dewar surrounded the test chamber and thereby maintained a constant temperature of  $-320^{\circ}$  F. The FLOX concentrations were controlled by using the graduated cylinder to measure required quantities of fluorine and oxygen. The supply and vent connections were made through a stainless-steel plate to which the glass cylinder was clamped, and a Teflon gasket was used between the glass and the plate. The test sample was lowered into and raised from the FLOX mixture by means of a remote push-pull rod system, which was also used to agitate the sample in the FLOX mixture. A steel cylinder, which could be purged with helium when it was desired to provide an inert atmosphere for the sample, was located above the test chamber to contain the sample between tests. All tubing and fittings were stainless steel or copper, and all oxygen, fluorine, and FLOX valves had metal-to-metal seats and Teflon packing. In gaseous FLOX testing, the liquid-nitrogen Dewar was removed, and FLOX concentrations were controlled by the use of visually readable rotameters as shown in figure 1. Two attractive features of this apparatus were (a) many

materials could be tested in a short period of time, and (b) the use of a glass test chamber allowed visual observation and photographic recording of reaction phenomena.

### Procedure

Test sample cleaning. - The cleaning procedure used for the samples tested in this program was as follows:

- (1) Washing with soap and water, rinsing with water, and drying in air; this step was used for samples which were visibly dirty from machining, handling, etc.
- (2) Washing with an appropriate cleaning solvent (listed in table V)
- (3) Thorough drying with clean, dry helium
- (4) Recleaning in the event of any accidental or suspected recontamination

Liquid tests. - In a typical static liquid FLOX compatibility test, a sample of known weight was secured to the movable sample holder rod, inserted by remote control into the FLOX mixture, and exposed to FLOX for 15 seconds. The sample was then agitated for another 45 seconds. If no reaction occurred, the sample was withdrawn into the helium-inerted tube; more fluorine was added to increase the concentration; and the sample was reimmersed. Percentage increases in fluorine concentration were arbitrarily chosen at the discretion of the operators, depending upon the material being tested. If the sample survived the maximum FLOX concentration (generally about 80 to 85 percent fluorine), it was then immersed and agitated in 100 percent liquid fluorine for 5 minutes. If the sample survived, it was then removed, inspected, and reweighed, and a new sample was inserted.

Gaseous tests. - In a typical gaseous FLOX test, the sample was held on a stationary sample holder. Gaseous FLOX at controlled concentration and pressure (2 lb/sq in. gage or less) was slowly passed through the test chamber for 3 minutes at each concentration. The concentration was increased by increasing the fluorine flow relative to the oxygen flow.

### DYNAMIC FLOX TESTS

#### Apparatus

The dynamic FLOX test installation, located at the Plum Brook Station, consisted of a closed-loop flow system, a test chamber for destructive testing, a large containment vessel, and a remote control room. A simple schematic diagram of the flow system is shown in figure 2. The vent system and the purge system are not shown in this diagram for the sake of clarity. The flow tank, the receiver tank, and the weigh tank were stainless steel, and all piping and tubing were stainless steel or copper. All valves shown in the diagram

were globe-type valves with metal bellows seals, metal-to-metal seats, and aluminum gaskets. The same type of valve was used in the vent system, but the purge system included both globe-type and diaphragm-type valves. The containment vessel, a 38-foot-diameter metal sphere, was used to ensure containment of reactions, FLOX spills, or other similar occurrences. The overall test facility is shown in figure 3.

In gaseous testing, only the weigh tank, the flow tank, and the receiver tank were immersed in liquid nitrogen. A surge tank was used to dampen pressure fluctuations, and a hot water heat exchanger was used both to ensure complete gasification and to obtain uniform temperatures.

Orifices were fabricated from the materials to be tested and placed between two concentrically serrated pipe stub ends as shown in figure 4. Pressure for sealing was provided by the bolted flanges. The orifice test specimens were designed to accomplish smooth flow through the passage. Grooves were cut around the outside of the specimens and "clamshell" brass adaptors inserted into the grooves to minimize the possibility of leaks at the serrations due to shrinkage of the specimens under cryogenic temperatures and to prevent compression distortion of the test piece from flange sealing pressure.

#### Procedure

Test sample cleaning. - The cleaning procedure for the samples was the same as that used for the static tests.

Liquid test. - In liquid FLOX testing, flow through the specimen was accomplished by pressurizing the flow tank with high-pressure helium while only slightly more than atmospheric pressure was maintained in the receiver tank. Test fluid was forced through only one specimen at a time. At each particular fluorine concentration, flow rates were increased in increments. Smaller increments were chosen as the suspected reaction point was approached. Flow rates were controlled by operation of a flow control valve downstream of the test sections. Mass flow rates were measured by both a rotating vane flowmeter and a Venturi meter for backup as shown in figure 2. Velocities  $V$  were calculated by use of the continuity equation

$$V = \frac{\dot{W}}{\rho A}$$

where

$A$  test sample flow area, sq ft

$\dot{W}$  mass flow rate, lb/sec

$\rho$  fluid density, lb/cu ft

Gaseous tests. - In gaseous FLOX testing, the supply tank pressure was maintained constant at 400 pounds per square inch gage (maximum working pressure for the gas tests), and flow velocities were controlled by means of a

valve downstream of the test sections. Mass flow was measured with a calibrated orifice upstream of the test sections. Upstream and downstream test section header pressures were also measured, and velocities were calculated by use of the equation for perfect gas flow through a nozzle (ref. 1):

$$V_2^2 = V_1^2 + \frac{2g_c k p_1 v_1}{k - 1} \left[ 1 - \left( \frac{p_1}{p_2} \right)^{(k-1)/k} \right]$$

where

$V_2$  test sample flow passage velocity, ft/sec

$V_1$  approach velocity, ft/sec

$g_c$  gravitational constant, 32.2 ft/sec<sup>2</sup>

$k$  specific-heat ratio,  $C_p/C_v$

$p_1$  upstream header pressure, lb/sq ft abs

$v_1$  specific volume, cu ft/lb

$p_2$  downstream header pressure, lb/sq ft abs

$C_p$  specific heat at constant pressure

$C_v$  specific heat at constant volume

## RESULTS

### STATIC FLUORINE AND FLOX TESTS

#### General

Results for all the materials tested statically in gaseous and liquid FLOX and fluorine are given in bar graph form in figures 5(a) (solid materials) and (b) (greases and water). The gap between the no-reaction bar and the reaction symbol exists because fluorine concentration was increased in increments; this gap represents the region between tested concentrations where reaction might or might not occur. The results showed that reactions with these materials do not occur simply because fluorine is present but are a function of the concentration of fluorine in the mixture. Chemical identification of all solid materials tested statically and dynamically is given in table I. These results are for conditions of atmospheric pressure, exposure times of from 1 to 5 minutes at each concentration, virtually zero flow, and carefully controlled conditions of cleanliness. It should not be assumed, for example, that a material is safe for use in a dynamic FLOX system even though it was statically tested with 100 percent fluorine without reacting. It is shown subsequently that these

materials reacted at lower concentrations under dynamic conditions.

Particular care should be taken in using the results of the tests with greases and water. Previous Lewis experience has shown that these materials sometimes initially exhibit an inhibition to reactions with fluorine but may react at any time without warning.

#### Liquid Tests

In static liquid testing, two types of reaction were observed: vigorous, smooth-burning reactions and rapid, explosive reactions.

A typical slow-burning surface reaction is shown in color photographs in figure 6. This sequence shows a neoprene O-ring being tested in 83.5 percent liquid FLOX (a fluorine-oxygen mixture containing 83.5 percent fluorine by weight). The reaction, once initiated, seemed to propagate itself over an increasingly large area. Burning was smooth and quiet. The 12 frame sequence shown occurred in 1/2 second.

An explosive reaction is shown in figure 7. The sample tested in this sequence was Bakelite, a phenol-formaldehyde, and the test fluid was 78 percent FLOX. The reaction occurred very rapidly (the six frames shown occurred within 1/24 sec) and was quite violent, considering the size of the sample (0.7 g).

#### Gaseous Tests

The gaseous static FLOX tests were run at ambient temperature and atmospheric pressure conditions. Some of the samples which reacted in the gaseous tests were observed to smolder before ignition. In other words, the sample appeared to react slowly until its combustion temperature was reached, at which time it ignited. All reactions with gaseous fluorine or FLOX were nonexplosive in static testing.

### DYNAMIC FLUORINE AND FLOX TESTS

#### Liquid Tests

Pressure effects. - Previous tests (ref. 2) with liquid and gaseous fluorine at two pressure levels, atmospheric and 1500 pounds per square inch gage, have shown an effect of pressure on reactivity under static conditions. Several materials which did not react at atmospheric pressure did react at 1500 pounds per square inch gage with gaseous and/or liquid fluorine. For this reason, attempts were made during the dynamic test program to determine the effect of pressure on reactivity. The following six materials were used: Teflon TFE, Rulon A, Kel-F 81, Teflon FEP, Kel-F 82, and Kynar.

The materials to be tested were fabricated into 0.56-inch-diameter orifices 0.25 inch long. Generally, the FLOX or fluorine flow was maintained constant through the orifices by the downstream flow control valve, while the upstream

pressure was varied from 25 to 400 pounds per square inch gage (the maximum system working pressure for this test period). All materials tested withstood both FLOX and 100 percent liquid fluorine at 400 pounds per square inch gage and a nominal flow rate of 2 pounds per second (12.25 ft/sec) for 30 seconds. It was apparent that the pressure range of 25 to 400 pounds per square inch gage was not great enough to obtain measurable data on the effect of pressure for these materials at the flow velocity selected.

Velocity effects. - These tests were performed to explore the effect of velocity on reactivity. The upstream pressure was varied as needed to obtain the desired flow velocities. The test specimens were 1-inch-long, 1/8- or 1/4-inch-diameter tubular orifices, and the typical exposure time was 30 seconds at each set of conditions. The following materials were tested in this configuration: Halon TFE, Teflon TFE, Plaskon 2400, Kel-F 81, Rulon A, Nickel-filled Teflon, Halon TVS, Teflon FEP, Kel-F 81 amorphous, Kel-F 82, Kynar, Viton A, Lucite, CPE 401, CPE 402, and CPE 403-XCL.

Maximum system working pressure was increased from 400 to 1500 pounds per square inch gage during the test program in order to increase maximum liquid flow velocity from 170 to approximately 330 feet per second. This increase was necessary because the original maximum conditions were not severe enough to cause reactions with polytetrafluoroethylene-type materials. These materials, Halon TFE G-80 and Teflon TFE, proved to be the most compatible of all materials tested, having withstood flow velocities in the region of 225 to 280 feet per second at high fluorine concentrations.

Reactions with all materials were combusive and ranged from smooth, slow-burning to rapid explosions. Generally, the highly fluorinated and chlorinated polymers produced slower, milder reactions than those having atoms such as hydrogen in their molecular structures or those containing noncompatible additives. There were, however, exceptions to this trend. A nonexplosive reaction of a specimen with liquid FLOX under dynamic conditions, for example, is shown in figure 8. The specimen was Lucite, a transparent plastic with a high hydrogen content which ignited in 50 percent FLOX at a flow velocity of 84 feet per second. This material was tested because its transparency allowed an inside view of the reaction by photographic means. In the first frame of figure 8, the FLOX is passing through the specimen. The second frame shows the reaction being initiated a fraction of a second later, the third frame shows the steady bright glow which continued for about 6 seconds, and the final frame shows the reaction after the specimen had burned through. The film speed was 24 frames per second. Figure 9 is a closeup view of the same reaction (the apparent distortion was caused by the immersion of the specimen in liquid nitrogen). In the first frame, the FLOX is flowing through the specimen (fluid not visible in the photographic print). The second frame shows the reaction initiation. In the actual motion-picture film, the flame is visibly more brilliant on the upstream side of the specimen flow passage. This indicates that the reaction had been initiated at the throat of the rounded orifice inlet, although photographic reproduction does not show this. The third frame shows the steady bright glow, and the fourth shows the burn through. Film speed was again 24 frames per second, but there was no attempt to synchronize this camera with the camera used for figure 8. The amount of heat produced was sufficient to melt and con-

some part of the metal flanges which held the specimen.

A nonexplosive reaction of a specimen with 100 percent liquid fluorine under dynamic conditions is shown in figure 10. The specimen is Kel-F 82, which ignited and glowed evenly for several seconds under a flow velocity of 35 feet per second.

An explosive reaction of a specimen with liquid fluorine under dynamic conditions is shown in figure 11. The first frame shows the five test sections with flow occurring in test section 5 (extreme right, Rulon A specimen). The following frames show the explosion which occurred an instant later.

From the data obtained, liquid FLOX reactivity profiles were generated for the selected materials. Since a material must be tested at several concentrations and flow velocities in order to generate a reactivity profile, only those materials of greatest interest were chosen. These reactivity profiles (fig. 12) show the areas of compatibility and noncompatibility as functions of fluorine concentration and flow velocity.

The dashed lines on these profiles represent an average through the highest nonreaction test points. As mentioned in the Procedure section under DYNAMIC FLOX TESTS, flow velocity was increased in arbitrary increments. Smaller increments were chosen as the suspected reaction point was approached in order to obtain nonreaction points as close to the reaction points as practical. The highest nonreaction test points are therefore not necessarily the highest nonreaction points attainable. The solid lines on these profiles are experimental limit lines, which include the lowest of the nonreaction test points and are drawn parallel to the average nonreactivity limit lines. In some cases (e.g., fig. 12(e)), the two curves coincide. The areas to the left of the solid lines are considered nonreactivity regions under ideal conditions.

Figure 13 is a composite of all the liquid FLOX reactivity profiles showing relative compatibilities of the different materials. In each case, the line shown is the maximum nonreactivity limit line. The greater resistance of the polytetrafluoroethylenes (TFE) is clearly shown. The Halon TFE samples were made specifically for these tests, whereas the Teflon TFE samples were from shelf stock made either to specification MIL P 19468 or the more rigid AMS 3656. Plaskon 2400 samples were also made specifically for these tests. Materials which were tested only once are represented in bar graph form in figure 14.

These results were obtained under smooth flow and other carefully controlled conditions of testing. In actual practice, a wide margin of safety should be used. Differences in reactivity with fluorine are possible with supposedly identical materials because of variations in fabrication processes, which may produce voids, impurities, or other differences in a material; therefore, materials selected for fluorine or FLOX environments should be of the highest possible quality. Because of the lack of statistical test information,

no fixed factor of safety can be given. The margin to be used should depend upon the acceptable level of risk for the particular application. In all applications of polymeric materials exposed to fluorine or FLOX, the severity of environmental conditions should be minimized as much as possible.

### Gaseous Tests - Velocity Effects

These tests were performed to explore the effect of velocity on reactivity with gaseous FLOX and fluorine. In short duration testing (30 sec at each set of conditions) with 1/4-inch-diameter orifice specimens, nine materials withstood maximum conditions of 100 percent gaseous fluorine flow at sonic velocity (about 900 ft/sec) for several seconds and average velocities from 700 to 880 feet per second. It was intended to expose these specimens to sonic velocity for the full 30 seconds, but because of the high mass flow through a 1/4-inch test orifice at maximum flow conditions, a rapid back-pressure buildup in the system reduced the velocity to less than sonic during the test runs. Table II gives a list of the nine materials, together with average velocities withstood without a reaction and the sonic velocity duration time.

A gaseous FLOX reactivity profile of Viton A is shown in figure 15. Reactions usually occurred with this material at or near sonic velocity before the back-pressure buildup had time to reduce the velocity. Only at a concentration of 34 percent fluorine was there no reaction at sonic velocity with this material. Sonic velocity was maintained for about 9 seconds at this concentration; then the velocity decreased to an average of 700 feet per second for 60 seconds.

## DISCUSSION

### VELOCITY EFFECTS

Dynamic FLOX tests have shown that several materials which did not react when exposed to fluorine and FLOX under static conditions were reactive under dynamic conditions. Kel-F 82, for example, reacted with 100 percent liquid fluorine when exposed to a velocity of 35 feet per second and with 60 percent FLOX when exposed to a velocity of 170 feet per second (fig. 12(c)). In dynamic gaseous FLOX tests the effect of velocity was also demonstrated. Viton A, which is a fluorinated synthetic rubber, did not react when exposed to gaseous fluorine under static conditions but did react with gaseous fluorine at a flow velocity of 585 feet per second and with gaseous 50 percent FLOX at a velocity of 900 feet per second (fig. 15). The same trend is noticed in all the reactivity profiles. The higher the flow velocity, the lower the fluorine concentration each material withstood. Increasing the velocity of the fluorine or FLOX increases the average energy state at the reaction zone and thereby increases the ability of the fluorine molecules to initiate a reaction. The energy of activation required for ignition of materials varies with the material. In other words, if two materials are subjected to identical conditions of fluo-

rine exposure and neither material ignites, it does not necessarily mean that the two materials are equally compatible with fluorine. One material may have been closer to its reaction point than the other. The energy of activation required for spontaneous ignition of metals is generally much greater than for polymers.

#### CHEMICAL COMPOSITION AND MOLECULAR STRUCTURE

The test results show that the compatibility of nonmetallic materials with fluorine and FLOX is also largely dependent upon their chemical composition and molecular structure. For example, Teflon FEP (fluorinated ethylene propylene) was more reactive than Teflon TFE (polytetrafluoroethylene). Table I shows the difference in molecular structure. Teflon TFE is a straight-chain polymer, whereas in the FEP molecule, every fourth carbon atom has linked to it another carbon atom in a side link. Because of the confusion sometimes created by both materials being called Teflon, simple laboratory procedures have been established for distinguishing between the two materials. These procedures are outlined in appendix B.

A comparison between the reactivity profiles of Kel-F 82 and Kel-F 81 (figs. 12(c) and (g)) shows that Kel-F 81 is more compatible with fluorine and FLOX. Table I shows a difference in their chemical composition as well as in their molecular structure. The Kel-F 81 molecule is a simple straight chain structure consisting of carbon, chlorine, and fluorine, whereas Kel-F 82 is a copolymer of chlorotrifluoroethylene and vinylidene fluoride, which also has a straight chain structure but contains some hydrogen atoms.

Rulon A, which is Teflon TFE impregnated with a molybdenum disulfide filler (for better wear characteristics), reacted with fluorine and FLOX at about half the velocity required for reaction of unimpregnated Teflon TFE. The presence of the filler is suspected of making the material more susceptible to attack by fluorine.

Nickel-filled Teflon (Teflon TFE impregnated with finely divided nickel particles) also reacted with 100 percent liquid fluorine at about half the velocity required for reaction of unimpregnated Teflon TFE, although nickel in bulk form is certainly compatible with fluorine. This reaction may have been caused by the finely divided state of the nickel or a difference in the surface texture created by the ingrained particles.

The trend was that the unimpregnated, highly fluorinated, and highly chlorinated materials were more compatible with FLOX and fluorine than materials containing atoms such as hydrogen in their molecular structure or materials impregnated with some noncompatible additive. The fluorinated polymers, particularly the fully fluorinated straight-chain polymers, were the most compatible materials.

## CRYSTALLINITY EFFECTS

Kel-F 81 in amorphous form (hereinafter called Kel-F 81 amorphous) was tested to determine the effect of crystallinity on reactivity. The crystallinity of a material is a measure of the orderliness of the molecules in its structure. A material with a disorderly molecular arrangement is considered amorphous, although materials are generally neither entirely crystalline nor amorphous. Different degrees of crystallinity are obtained by varying the cooling rate during the molding process. The faster the cooling rate, the more amorphous the material will be. Figure 16 shows reactivity profiles of Kel-F 81 at different degrees of crystallinity. The relative positions of these curves show that Kel-F 81 amorphous reacted under less severe conditions than crystalline Kel-F 81. An attempt was made to transform Kel-F 81 amorphous to crystalline form. Two amorphous specimens were heated to a temperature just below their melting point and allowed to cool slowly (33° F/hr) to room temperature, which transforms the material from amorphous to crystalline. These specimens were then tested in the same manner as the other Kel-F 81 specimens, and the results are shown in figure 16. The reactivity profile falls in the same general position as that of the crystalline Kel-F 81. On the basis of the limited number of data points, the heat-treating process did increase the resistance of the material to FLOX. These tests indicate that the orderly arrangement of the molecules in the crystalline case makes the material less susceptible to fluorine attack than in the amorphous case with its irregular molecular alignment.

X-ray diffraction photographs were taken to measure the crystallinity of Kel-F and other materials. Figure 17 shows X-ray diffraction photographs of five different materials. The relative degree of crystallinity is estimated from the relative sharpness of the diffraction rings. Teflon TFE appears to be more crystalline than Teflon FEP. The difference in crystallinity is similarly observed between crystalline Kel-F 81 and Kel-F 81 amorphous. The heat-treated Kel-F 81 amorphous shows a degree of crystallinity quite similar to that of the crystalline Kel-F 81. These photographs verify that the heat-treating process did transform the amorphous material to a more crystalline state, and the test results indicate that the higher state of crystallinity resulted in a greater resistance to the fluorine environment.

## EXPOSURE TIME EFFECTS

A limited number of tests were performed on some materials with fluorine and FLOX under gaseous dynamic conditions to gain information on the effect of exposure time. In order to attain sustained high velocities, it was necessary to reduce the specimen orifice diameter from 1/4 to 1/8 inch to avoid the previously mentioned back-pressure buildup. Three specimens were tested, Teflon TFE, Kel-F 81 amorphous, and Kel-F 82, and sustained velocities up to a maximum of sonic were attained in each case. Teflon TFE successfully withstood 100 percent gaseous fluorine flow at the sonic velocity of 900 feet per second for 30 minutes. Kel-F 81 amorphous ignited after 5 minutes at 900 feet per second, and Kel-F 82 ignited after 15 minutes of flow at 900 feet per second; however, both specimens had just previously been exposed to lower flow velocities (see table III) for 30 minutes without reacting.

A Viton A specimen was exposed to gaseous 50 percent FLOX flow at 200 feet per second for 30 minutes. There was no reaction at this velocity during the extended time run. In order to obtain an additional data point for this material, the specimen was then subjected to the sonic velocity of 900 feet per second. The specimen reacted almost immediately.

The effect of exposure time on reactivity of liquid FLOX was not specifically examined; however, many short duration test runs were consistently made on the same test specimen with no effect until the reaction conditions for the material (concentration and velocity) were reached. The reaction points seemed to be independent of the total exposure time leading up to the reaction conditions. In addition, past Lewis experience has shown that some nonmetals, Teflon TFE, for example, can be used successfully in valves for packing and seats for prolonged time durations. Exposure time in itself is therefore not felt to be a significant factor in either the gaseous or the liquid FLOX case. It may have some effect at marginal exposure conditions of fluorine concentration and flow velocity; however, it would require more statistical-type testing, including some very long run times (hours rather than minutes), to verify this possibility.

#### LIQUID AND GASEOUS FLOX COMPARISON

Since a temperature difference of 350° F or more existed between liquid (-320° F) and gaseous (30° to 70° F) test conditions, it was initially expected that, with gas at the higher temperature or enthalpy, the flow velocity and/or fluorine concentration required for reaction would be less than for the liquid case. Normally, at the higher temperature, a material is closer to its enthalpy of activation; however, the static test results of figure 5 show that reactions occurred more readily in the liquid than in the gas for particular fluorine concentrations. The evidence indicates that the higher molecular density (number of fluorine molecules per unit volume) of the liquid has an important effect on reaction initiation. This evidence is supported by the static test results of reference 2, which indicate that the gaseous fluorine at high pressure (1500 lb/sq in. gage) is more reactive than at ambient pressure. In this case, the combination of higher molecular density of the high-pressure gas plus the greater enthalpy at room temperature enhances reaction initiation as does the higher molecular density of the liquid at cryogenic temperature. The decreased reactivity due to the diluent effect of oxygen in a FLOX mixture also seems to substantiate the premise that reactivity is partly a function of the molecular density of fluorine at a potential reaction zone.

The greater reactivity of the cryogenic liquid was also noticed in the dynamic tests. A comparison between the liquid and the gaseous reactivity profiles for Viton A (figs. 12(a) and 15) shows that much higher velocities were required to obtain reactions with gaseous FLOX than with liquid FLOX at similar concentrations. This fact, together with the fact that many other materials which did not react with gaseous fluorine at sonic velocity did react with liq-

uid FLOX at much lower velocities, is evidence that the cryogenic liquid is more reactive than the ambient-temperature gas at pressures up to 400 pounds per square inch gage. The effect of higher molecular density in the liquid case seems to exceed the effect on reactivity which is normally characteristic of increases in temperature and enthalpy.

#### REACTION RATES

As previously mentioned, some of the materials seemed to burn slowly and others explosively in fluorine or in FLOX. Table IV(a) lists the materials and how they reacted under static conditions. Blank spaces in this table mean that the material either did not react in the manner indicated at the head of the column or was not tested under those conditions. Graphite, which is a very porous material, reacted explosively from static exposure to 100 percent liquid fluorine after a delay of  $1\frac{1}{2}$  minutes. After the test, 85 percent of the sample was intact. Generally, the fluorocarbon and chlorocarbon polymers tended to react more slowly than other materials. It was consistently observed that once a reaction had been initiated, the rate of reaction was not affected by the concentration of fluorine in the FLOX mixture.

Table IV(b) lists the materials and how they reacted under dynamic conditions. Rulon A (Teflon TFE impregnated with a molybdenum disulfide filler) reacted explosively, whereas the nonimpregnated Teflons burned smoothly. Evidently, the presence of the filler affected not only the material's reaction point but also its rate of reaction. Kynar, which is an unimpregnated resin, also reacted explosively. Table I shows, however, that this material contains many hydrogen atoms in the side links of its molecular structure.

An observation made in connection with the explosive reactions was that in both static and dynamic cases a large portion of the sample usually remained after the reaction. As in the case of graphite, the materials may absorb FLOX interstitially to a certain depth. When reaction occurs, it involves only that portion of the material which has absorbed FLOX, and the explosive effect separates the reactant from the unreacted material and thus prevents further reaction.

The slow-burning reactions were initiated at the surface of the materials, progressed over an increasingly large area, and burned inward until the source of reactant was depleted or removed. The photographs of the nonexplosive reaction shown in figure 6 (neoprene) illustrate this type of reaction.

A thorough investigation of reaction mechanisms and reaction rates was beyond the scope of this program. These subjects, however, warrant a more complete investigation.

#### SYSTEM CLEANLINESS

The importance of cleanliness in a fluorine system is generally well recognized. All fluorine or FLOX systems must be free from dirt, oil, grease,

moisture, and other such contaminants. Reactions of fluorine or FLOX with these foreign materials can trigger a reaction with the parent material. This is particularly true for polymers because of the relatively low activation energies required for spontaneous ignition as compared with metals. The cleaning procedure used for the samples tested in this program is given in the Procedure section of this report, and the cleaner and the solvents used for the various materials are given in table V. The solvents were chosen on the basis that they would not tend to dissolve the particular material nor be absorbed by the material to an appreciable degree. The samples were not soaked in the solvents for an extended period of time.

### SUMMARY OF RESULTS

In an investigation of the compatibility of polymeric materials with fluorine and fluorine-oxygen (FLOX) mixtures, the following results were obtained:

1. Reactions between FLOX (fluorine-oxygen mixture) and polymeric materials under static conditions were a function of the concentration of fluorine in the mixture, which reflects the quantity of fluorine molecules per unit volume. Under dynamic conditions, at any given fluorine concentration, flow velocity was a highly significant parameter in the reactivity of FLOX with all materials tested.
2. The compatibility of polymeric materials with fluorine and FLOX was largely dependent upon their chemical composition and molecular structure. Generally, the unimpregnated, highly fluorinated and highly chlorinated materials were more compatible than materials containing atoms such as hydrogen in their molecular structure or materials impregnated with some noncompatible additive. The fluorocarbon polymers, particularly the fully fluorinated straight-chain polymers, such as Halon TFE and Teflon TFE, were the most compatible with fluorine and FLOX.
3. The reactivity of the materials tested was affected by their crystallinity. Materials with higher crystallinity (orderly molecular alignment) were more resistant to attack by fluorine and FLOX than the more amorphous materials (disorderly molecular alignment).
4. In both static and dynamic FLOX tests, a comparison between cryogenic-liquid ( $-320^{\circ}$  F) and ambient-temperature gaseous ( $30^{\circ}$  to  $70^{\circ}$  F) test results indicated that the liquid was the more reactive at pressures up to 400 pounds per square inch gage.
5. Generally, the highly fluorinated and highly chlorinated polymers produced slower, milder reactions than those having atoms such as hydrogen in their molecular structures or those containing noncompatible additives. It was consistently observed that once reaction had been initiated, the rate of reaction was not noticeably affected by the concentration of fluorine in the FLOX mixture.

## CONCLUSIONS

The following conclusions were drawn from the results of an investigation of the compatibility of polymeric materials with fluorine and fluorine-oxygen (FLOX) mixtures:

1. Some polymeric materials may be considered for use in rocket systems with fluorine or FLOX under controlled conditions of exposure; however, because of possible variations in quality and because polymers are more sensitive to contamination than metals in a fluorine environment, a margin of safety should be provided based upon the acceptable level or risk for the particular application. Where flight reliability is required, qualification testing must be performed.

2. Generally, the highly fluorinated and highly chlorinated materials are more suitable for use in fluorine or FLOX systems than materials containing atoms such as hydrogen in their molecular structures or materials impregnated with some noncompatible additive. Of all materials tested, the polytetrafluoroethylenes, Halon TFE and Teflon TFE, are the most promising for practical application in fluorine or fluorine-oxygen environments.

3. The strong significance of flow velocity on reactivity of polymeric materials with fluorine or FLOX indicates that some of these materials are suitable for use as static seals if it is assumed that no contamination is present. Exposure to direct flow should be avoided except under conditions where the risk is acceptable.

4. The orderly molecular arrangement of the more crystalline type materials makes them less susceptible to fluorine attack than the amorphous materials with their irregular molecular alignment. A material selected for use should therefore be of the highest crystalline form available for the particular material that has the desired mechanical properties.

5. The reactivity of polymeric materials with fluorine and FLOX increases as a function of molecular density (number of fluorine molecules per unit volume) present at the point of reaction initiation.

Lewis Research Center,  
National Aeronautics and Space Administration,  
Cleveland, Ohio, December 10, 1965.

## APPENDIX A

### MISCIBILITY TESTS

Tests were performed to verify the miscibility of liquid oxygen and liquid fluorine and to demonstrate their mixing characteristics. The apparatus was the same as that used in static FLOX compatibility tests (fig. 1). Equal amounts of gas were condensed at atmospheric pressure and liquid-nitrogen temperature ( $-320^{\circ}$  F) with no agitation.

Preliminary tests were made with liquid nitrogen (50 lb/cu ft) and liquid oxygen (75 lb/cu ft). When nitrogen was condensed upon liquid oxygen, a definite interface formed. Mechanical agitation (by the sample holder) was ineffective in mixing the two fluids; however, upon mixing by helium bubbling, they remained mixed and apparently homogenous for the observed time of 15 minutes. A comparison test was performed by the condensation of nitrogen onto FLOX; the liquid nitrogen in this case diffused and mixed with the FLOX as it was condensed. Apparently, the presence of fluorine enhanced self mixing.

During the condensation of oxygen onto liquid fluorine (97 lb/cu ft), an interface formed. At this interface, the pale-bluish color of LOX immediately began changing to the characteristic yellowish-amber color of fluorine as the interface began to rise. The interface was evidently a result of the rate of condensation being greater than the rate of diffusion of the fluorine into the LOX. (A stationary interface could not be maintained.) The rate at which the interface ascended was approximately  $1/4$  inch per minute. In approximately 15 minutes, the total contents of the vessel (diam., 2 in.) appeared uniform in color and so remained for an observed time of 5 minutes. These miscibility tests indicated that liquid oxygen and liquid fluorine are miscible in all proportions and tend to be self-mixing. Since this self-mixing occurred slowly, some mixing process, such as helium bubbling, is recommended in practice to assure immediate and thorough mixing, particularly in large systems.

## APPENDIX B

### TEFLON TFE AND TEFLON FEP DIFFERENTIATION TEST

FLOX compatibility tests indicated that Teflon TFE is preferable to Teflon FEP for use with this oxidizer; however, it is not immediately apparent in some cases whether a Teflon component consists of TFE or FEP because of such factors as artificial pigmentation or thinness of material. At ambient temperatures, unpigmented TFE of substantial thickness normally has an opaque, milky-white color. When TFE is heated to about 500° F, it begins to decompose to gaseous products in trace quantities. This decomposition increases with increasing temperature. At about 600° F, it becomes translucent, and above 620° F, it becomes an amorphous gel. Normally, FEP has a pale-gray, translucent appearance, but sometimes it has a very light-bluish or light-brownish tint. It melts to a very viscous fluid above 530° F. In order to distinguish Teflon TFE from FEP, the following laboratory test is recommended:

The Teflon component or a representative sample should be heated to approximately 600° F for about 20 minutes in a standard laboratory oven. If multiple samples are available, they can be stacked during heating to test for adhesion. If possible, a weight load may be applied to the specimen to test for deformation. Upon removal from the oven, the Teflon samples should have the following characteristics:

#### (1) TFE

(a) Configuration of the sample will not have changed; that is, sharp corners, bends, etc. remain intact.

(b) During cooling, an unpigmented specimen will change from a translucent condition to its original opaqueness.

(c) The sample will not adhere to itself.

(d) The sample will not have deformed under load.

#### (2) FEP

(a) The sample will show definite signs of melting; sharp corners will not exist.

(b) Only a slight, if any, change in translucency will be evident during cooling.

(c) The sample will adhere to itself.

(d) The sample will have deformed under load.

#### REFERENCES

1. Smith, Joe M.: Introduction to Chemical Engineering Thermodynamics. McGraw-Hill Book Co., Inc., 1949.
2. Price, Harold G., Jr.; and Douglass, Howard W.: Nonmetallic Material Compatibility With Liquid Fluorine. NACA RM E57G18, 1957.
3. Russell, Louis M.; Schmidt, Harold W.; and Clarke, Robert F.: Reaction Characteristics of FLOX Spills Upon Various Materials. NASA TN D-3118, 1966.

TABLE I. - MATERIALS IDENTIFICATION

Trade name	Chemical name or description	Molecular structure
Teflon TFE	Polytetrafluoroethylene	$\left[ \begin{array}{c} \text{F} \quad \text{F} \\   \quad   \\ -\text{C} - \text{C}- \\   \quad   \\ \text{F} \quad \text{F} \end{array} \right]_n$
Halon TFE, G-80	Polytetrafluoroethylene	$\left[ \begin{array}{c} \text{F} \quad \text{F} \\   \quad   \\ -\text{C} - \text{C}- \\   \quad   \\ \text{F} \quad \text{F} \end{array} \right]_n$
Rulon A	Polytetrafluoroethylene with MoS <sub>2</sub> filler	$\left[ \begin{array}{c} \text{F} \quad \text{F} \\   \quad   \\ -\text{C} - \text{C}- \\   \quad   \\ \text{F} \quad \text{F} \end{array} \right]_n + \text{MoS}_2$
Nickel-filled Teflon	Polytetrafluoroethylene with nickel-powder filler	$\left[ \begin{array}{c} \text{F} \quad \text{F} \\   \quad   \\ -\text{C} - \text{C}- \\   \quad   \\ \text{F} \quad \text{F} \end{array} \right]_n + \text{Ni}$
15-Percent glass-filled Teflon	Polytetrafluoroethylene with glass fibers	$\left[ \begin{array}{c} \text{F} \quad \text{F} \\   \quad   \\ -\text{C} - \text{C}- \\   \quad   \\ \text{F} \quad \text{F} \end{array} \right]_n + \text{Glass}$
Kel-F 81	Polychlorotrifluoroethylene (CTFE)	$\left[ \begin{array}{c} \text{F} \quad \text{Cl} \\   \quad   \\ -\text{C} - \text{C}- \\   \quad   \\ \text{F} \quad \text{F} \end{array} \right]_n$
Flaskon 2400	Polychlorotrifluoroethylene (CTFE)	$\left[ \begin{array}{c} \text{F} \quad \text{Cl} \\   \quad   \\ -\text{C} - \text{C}- \\   \quad   \\ \text{F} \quad \text{F} \end{array} \right]_n$
Halon TWS (now called Flaskon 2200)	Polychlorotrifluoroethylene (CTFE)	$\left[ \begin{array}{c} \text{F} \quad \text{Cl} \\   \quad   \\ -\text{C} - \text{C}- \\   \quad   \\ \text{F} \quad \text{F} \end{array} \right]_n$
Teflon FEP	Fluorinated ethylene propylene	$\left[ \begin{array}{c} \text{F} \quad \text{F} \quad \text{F} \quad \text{F} \\   \quad   \quad   \quad   \\ -\text{C} - \text{C} - \text{C} - \text{C}- \\   \quad   \quad   \quad   \\ \text{F} \quad \text{F} \quad \text{F}-\text{C}-\text{F} \quad \text{F} \\ \quad \quad \quad   \\ \quad \quad \quad \text{F} \end{array} \right]_n$
Kynar	Vinylidene fluoride	$\left[ \begin{array}{c} \text{H} \quad \text{F} \quad \text{H} \quad \text{F} \\   \quad   \quad   \quad   \\ -\text{C} - \text{C} - \text{C} - \text{C}- \\   \quad   \quad   \quad   \\ \text{H} \quad \text{F} \quad \text{H} \quad \text{F} \end{array} \right]_n$
Kel-F 82	Copolymer of CTFE and 3 mole percent vinylidene fluoride	-----
Mylar	Polyethylene terephthalate	$\left[ \begin{array}{c} \text{H} \quad \text{H} \\   \quad   \\ \text{O}=\text{C} - \text{C} = \text{C} - \text{C} = \text{C} - \text{C}=\text{O} - \text{O} - \text{C} - \text{C} - \text{O} - \\   \quad   \quad   \quad   \quad   \quad   \quad   \quad   \\ \text{H} \quad \text{H} \quad \text{H} \quad \text{H} \quad \text{H} \quad \text{H} \end{array} \right]_n$
Lucite	Polymethyl methacrylate	$\left[ \begin{array}{c} \text{H} \quad \text{O} = \text{C} - \text{OCH}_3 \\   \quad   \\ -\text{C} - \text{C} - \\   \quad   \\ \text{H} \quad \text{CH}_3 \end{array} \right]_n$
Tygon	Polyvinyl chloride-acetate	$\left[ \begin{array}{c} \text{H} \quad \text{Cl} \quad \text{H} \quad \text{Cl} \quad \text{H} \quad \text{O} \\   \quad   \quad   \quad   \quad   \quad    \\ -\text{C} - \text{C} - \text{C} - \text{C} - \text{C} - \text{C} - \text{O} - \text{C} - \text{CH}_3 \\   \quad   \quad   \quad   \quad   \quad   \\ \text{H} \quad \text{H} \quad \text{H} \quad \text{H} \quad \text{H} \quad \text{H} \end{array} \right]_n$
Nylon	Polyamide	$\left[ -\text{C} - \begin{pmatrix} \text{H} \\   \\ \text{C} \\   \\ \text{H} \end{pmatrix} - \text{C} - \text{N} - \begin{pmatrix} \text{H} \\   \\ \text{C} \\   \\ \text{H} \end{pmatrix} - \text{N} \right]_n$
Bakelite	Phenol formaldehyde	Not available



TABLE II. - GASEOUS-FLUORINE COMPATIBILITY TESTS

Material (1/4-in. tubular orifice)	Duration of sonic velocity, (900 ft/sec), sec	Average velocity for 30-sec period, ft/sec
Halon TFE	10	825
Teflon TFE	Unknown <sup>a</sup>	Unknown <sup>a</sup>
Rulon A	11	750
Kel-F 81	4	825
Teflon FEP	5	750
Halon TVS	8	700
Kel-F 81 amorphous	9	850
Kel-F 82	16	880
Kynar	2	825

<sup>a</sup>Instrument malfunction.

TABLE III. - GASEOUS-FLUORINE TIME EXPOSURE TESTS

Material (1/8-in. tubular orifice)	No reaction		Reaction	
	Velocity, ft/sec	Time, min	Velocity, ft/sec	Time, min
Teflon TFE	900 (Sonic)	30	-----	--
Kel-F 81 amorphous	372	30	900 (Sonic)	5
Kel-F 82	279	30	900 (Sonic)	15

TABLE IV. - TEST REACTIONS

(a) Static tests

Material	Type of reaction			
	Smooth burning		Explosive burning	
	Gas	Liquid	Gas	Liquid
Viton A		✓		
IS-53	✓	✓		
IS-63		✓		
Tygon		✓		
Neoprene		✓		
Polyurethane foam	✓			
Graphite				✓
Nylon				✓
Polyethylene				✓
Buna N				✓
Bakelite				✓

(b) Dynamic tests

Teflon TFE		✓		
Halon TFE		✓		
Kel-F 81		✓		
Plaskon 2400		✓		
Halon TVS		✓		
Nickel-filled Teflon		✓		
Teflon FEP		✓		
Kel-F 81 amorphous	✓	✓		
Kel-F 82	✓	✓		
Lucite		✓		
Rulon A				✓
Kynar				✓
Viton A			✓	✓
CPE 401		✓		
CPE 402				✓
CPE 403-XCL		✓		

TABLE V. - SPECIMEN CLEANING SOLVENTS

[Initial cleaner, soap and water.]

Cleaning solvent (a)	Material
Trichloroethylene <sup>b</sup>	Halon TFE Teflon TFE Teflon FEP Nickel-filled Teflon Rulon A Mylar Kynar
Acetone	Kel-F 81 Kel-F 81 amorphous Plaskon 2400 Halon TVS
Methanol	Kel-F 82
Hydrofluoric acid	Graphite
Alcohol	All CPE's

<sup>a</sup>These solvents are not necessarily recommended solvents but were those used by the experimenters. The samples were not soaked in the solvents for an extended period of time.

<sup>b</sup>Successfully used on all other materials for which basis for choice was not found.

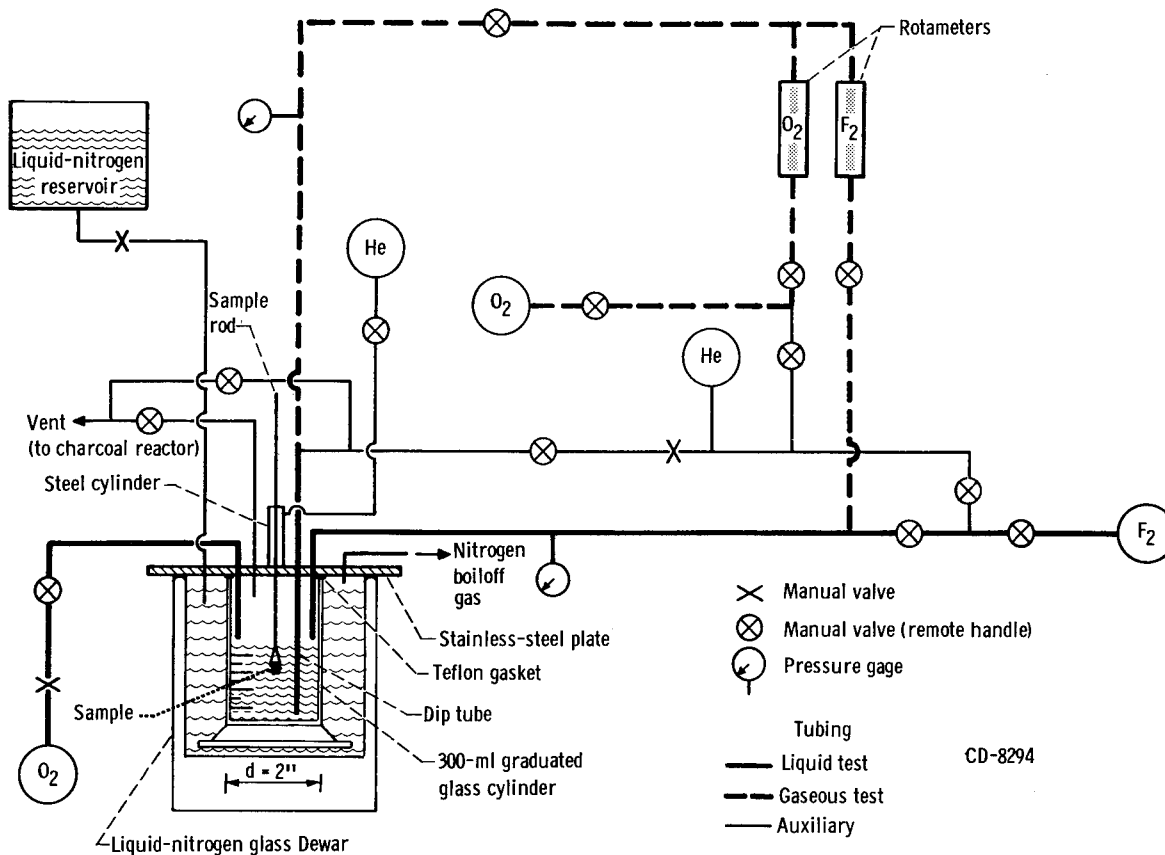

Figure 1. - Static FLOX system (not to scale).

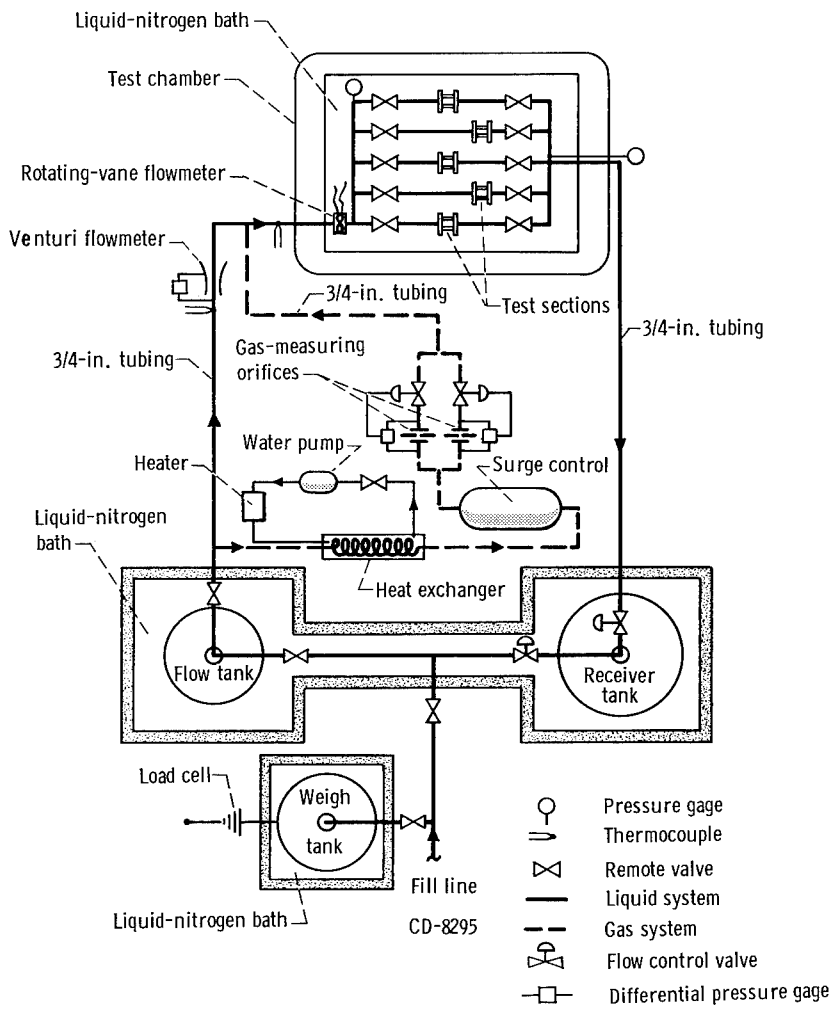
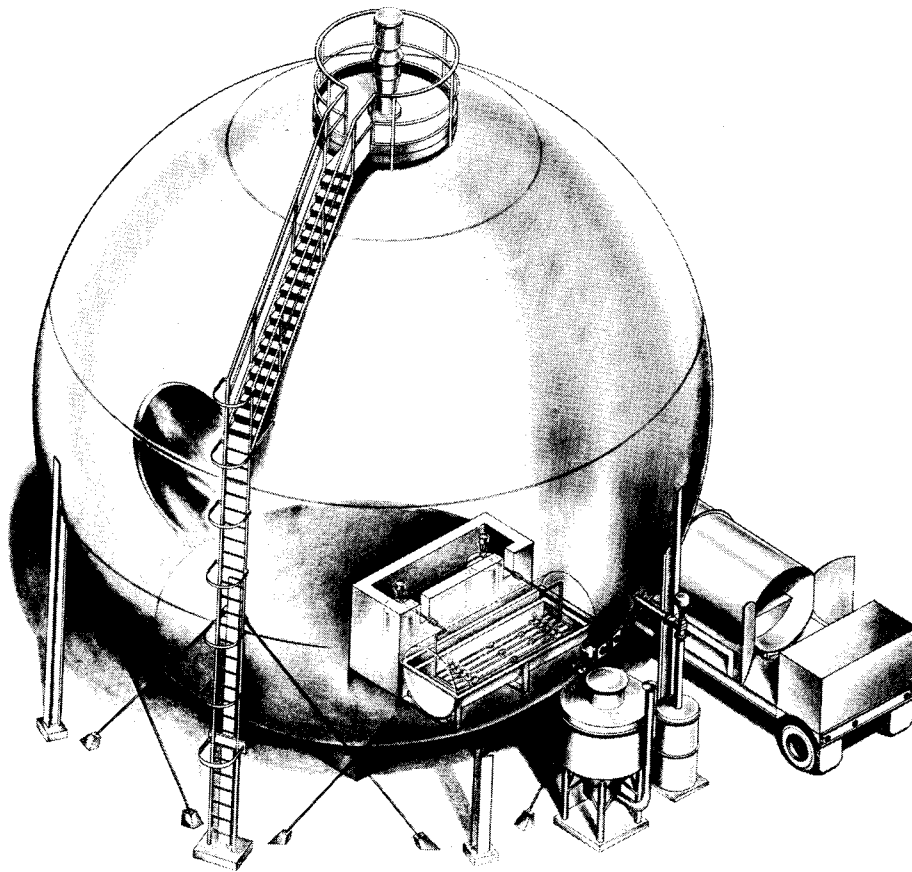
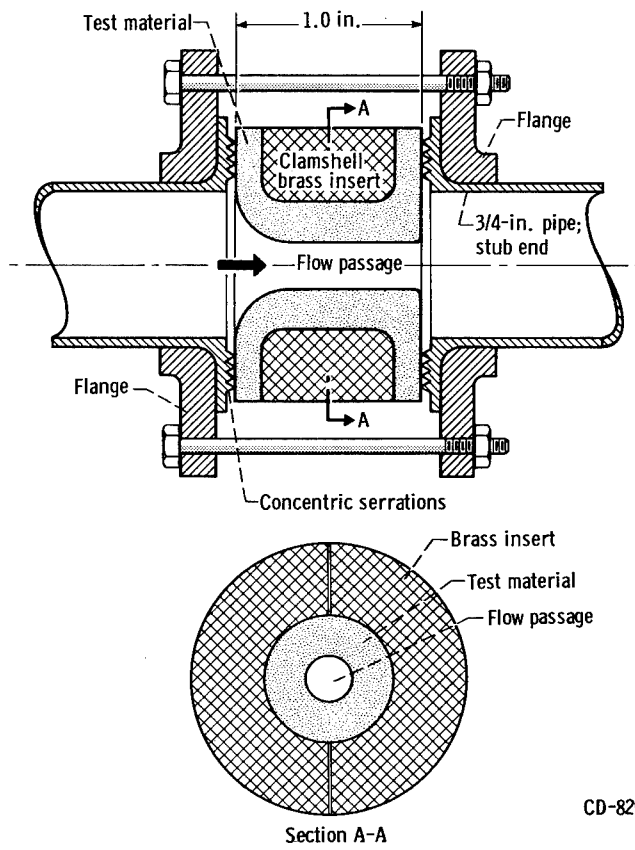

Figure 2. - Dynamic FLOX flow diagram (not to scale).



CD-8342

Figure 3. - Dynamic FLOX test facility.



CD-8293

Figure 4. - Dynamic FLOX test specimen holder (not to scale).

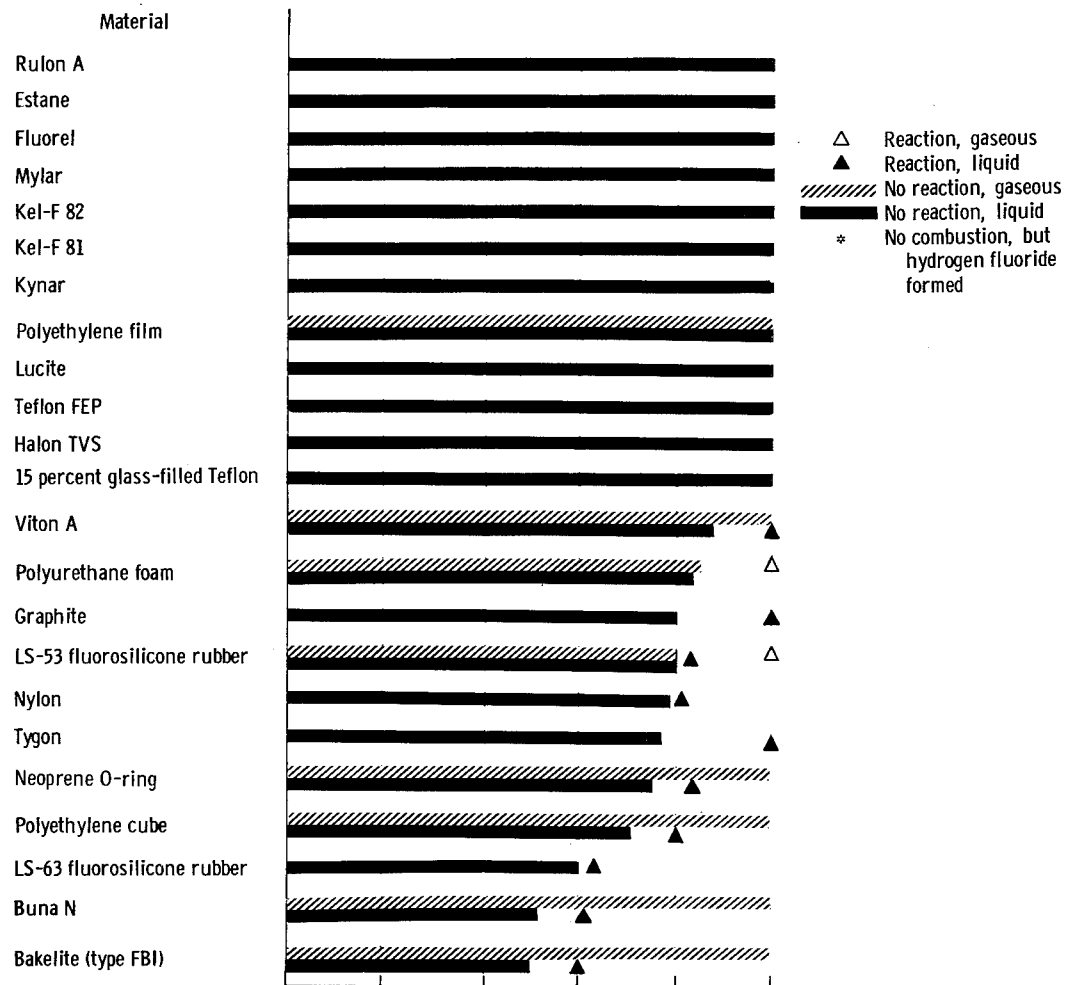

(a) Solid materials.

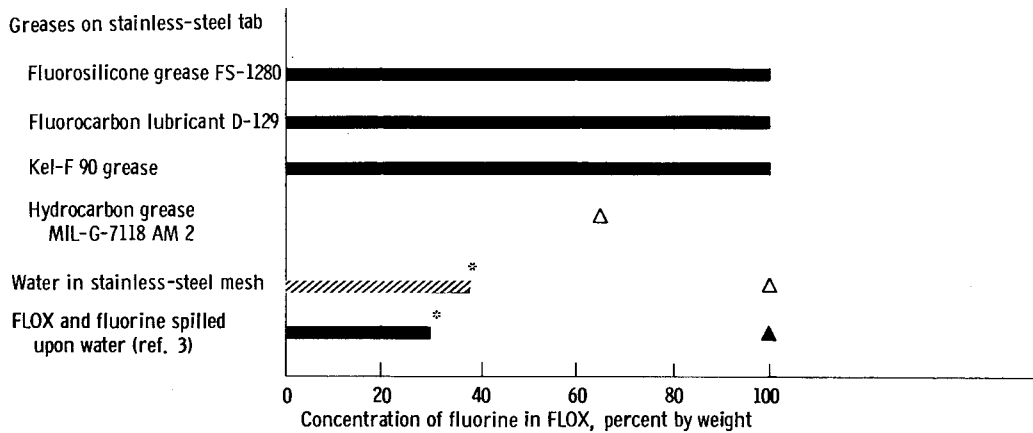

(b) Greases and water.

Figure 5. - Static FLOX compatibility test results. Liquid FLOX temperature,  $-320^{\circ}\text{F}$ ; gaseous FLOX temperature,  $20^{\circ}$  to  $40^{\circ}\text{F}$ ; pressure, atmospheric. (These results should not be used as a guide in selecting materials for use under dynamic conditions or for pressures greater than atmospheric.)

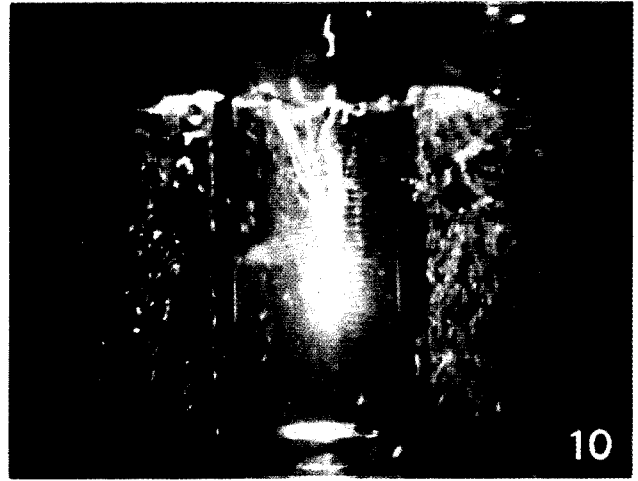
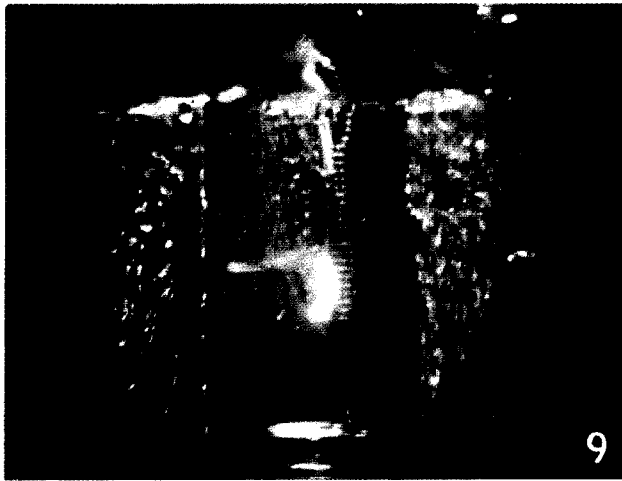
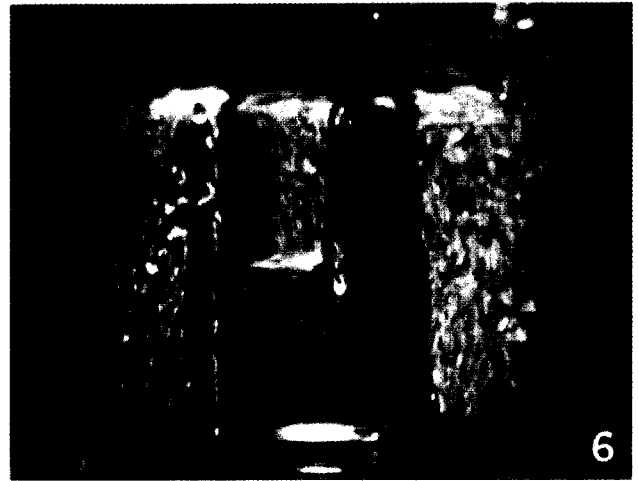
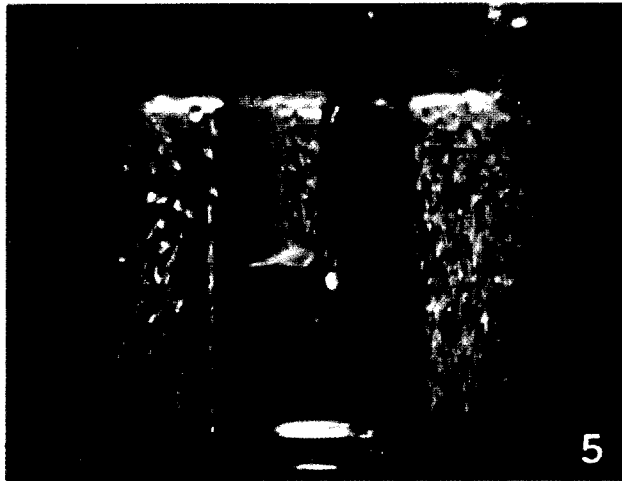
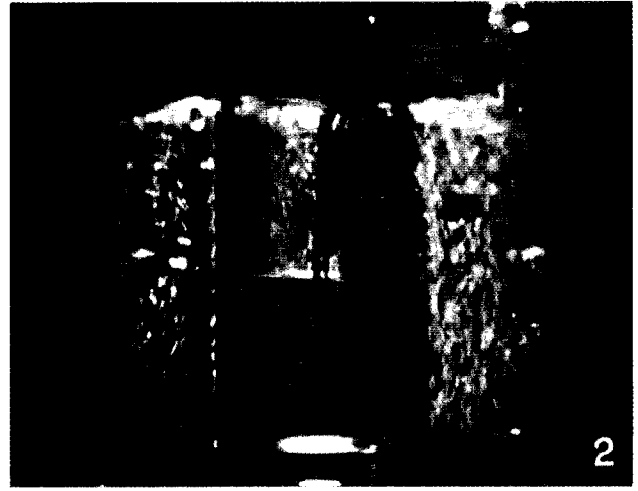
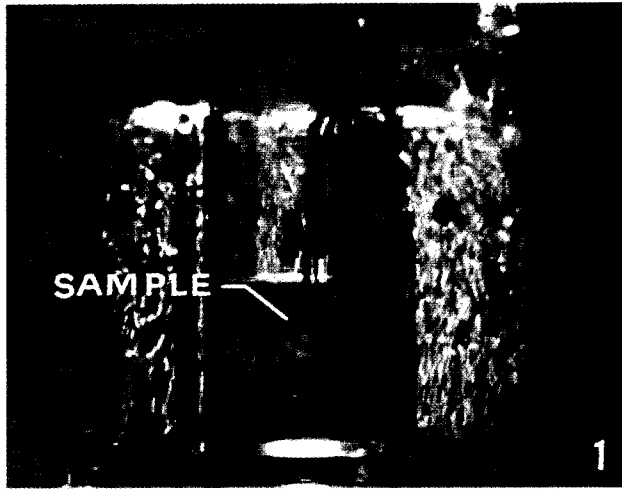
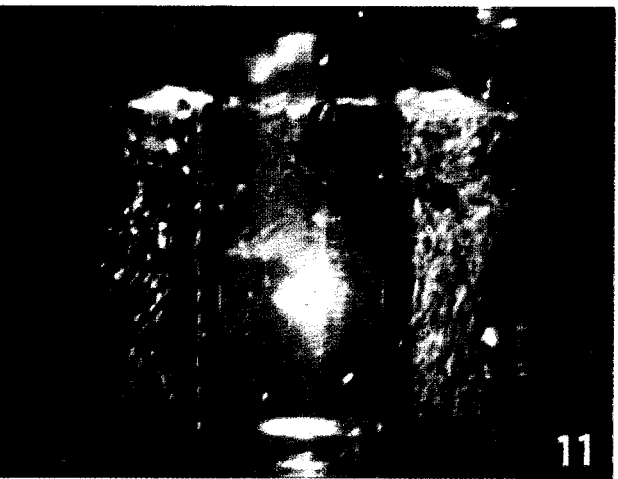
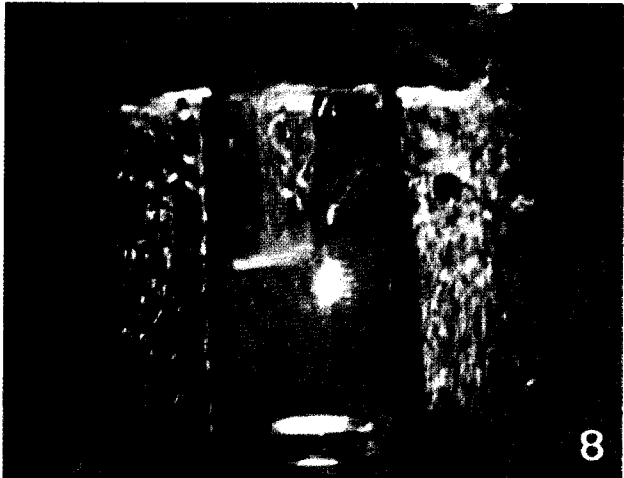
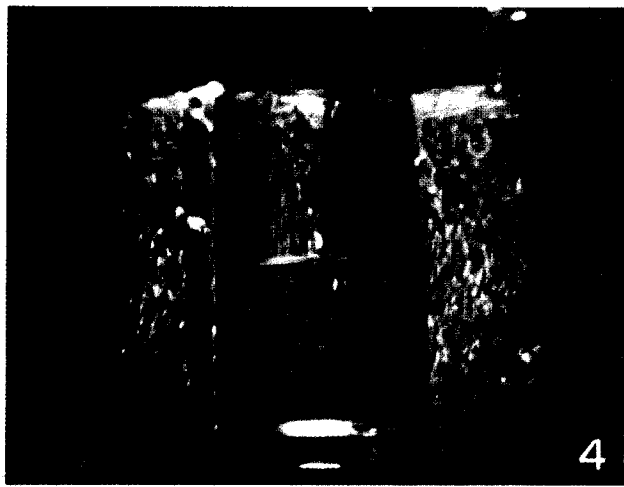
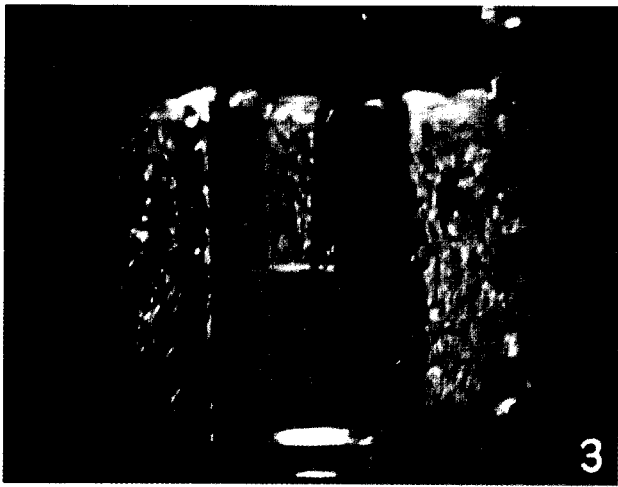
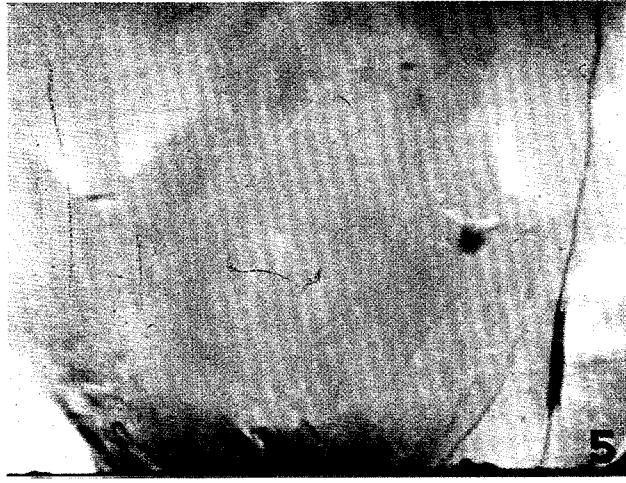
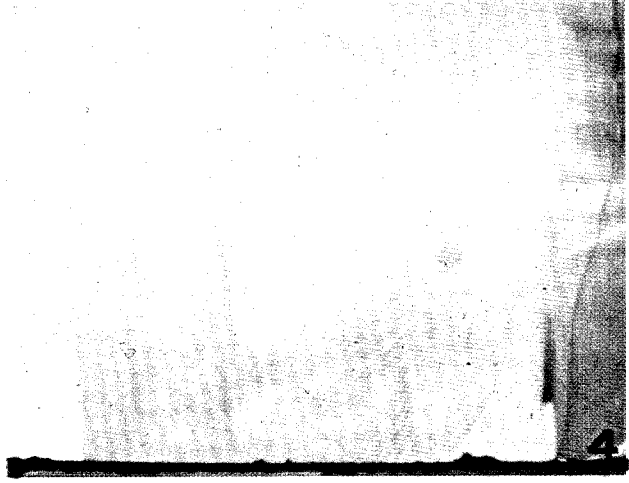
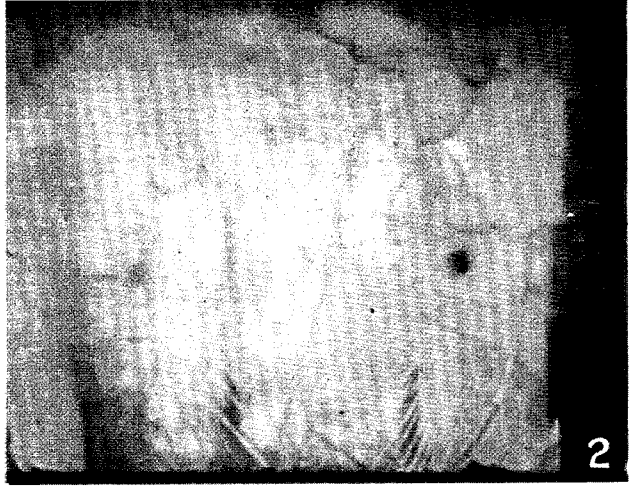
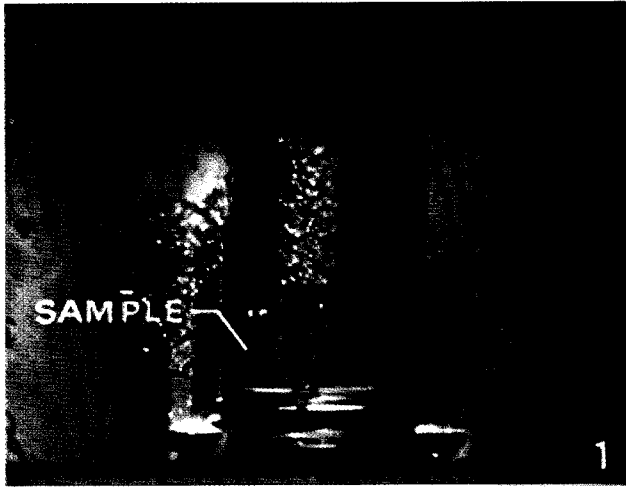

Figure 6. - Static liquid FLOX compatibility test for



Neoprene O-ring. Film speed, 24 frames per second.



C-65-3600

Figure 7. - Static liquid FLOX compatibility test for Bakelite. Film speed, 144 frames per second.

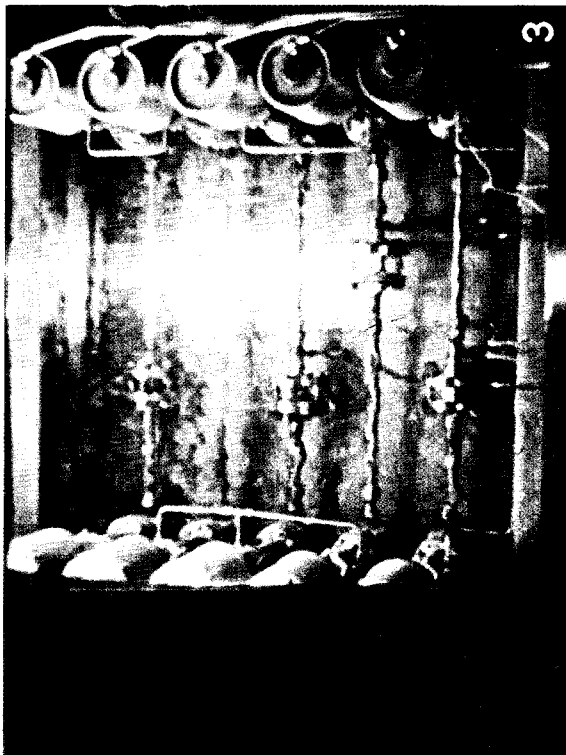
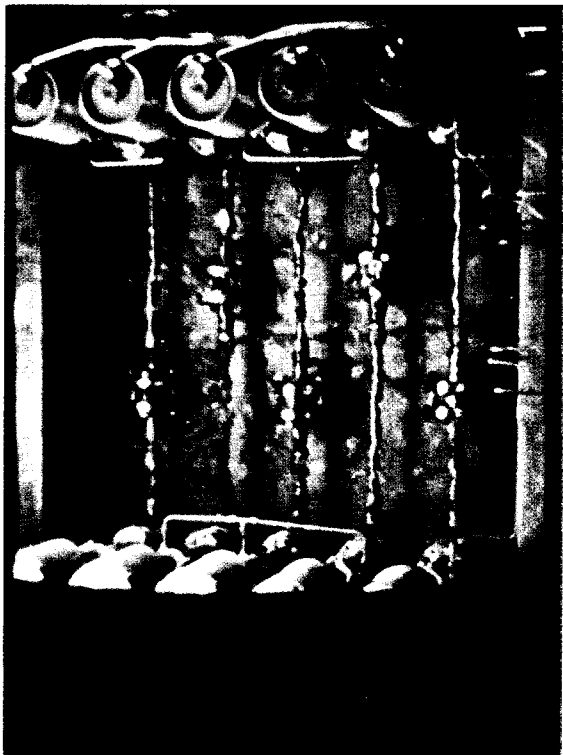
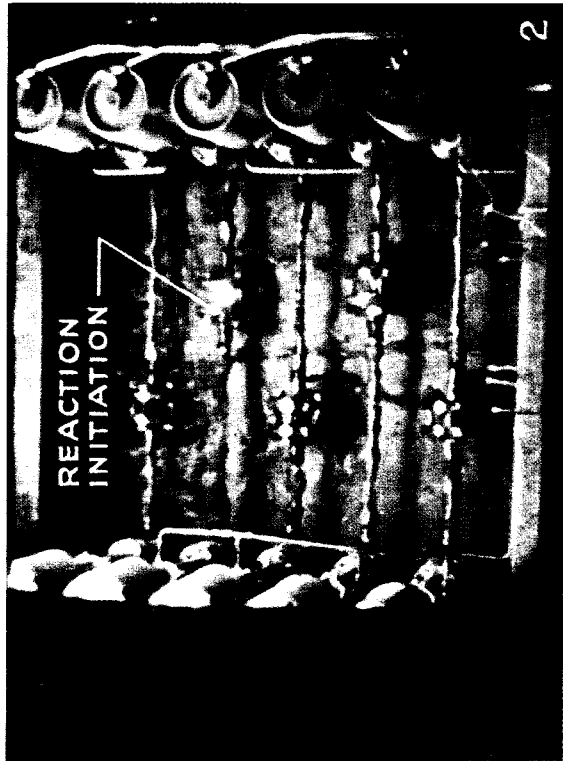

C-65-3601

Figure 8. - Dynamic ELOX compatibility test for Lucite. Film speed, 24 frames per second; time interval between frames 3 and 4, 9 seconds.

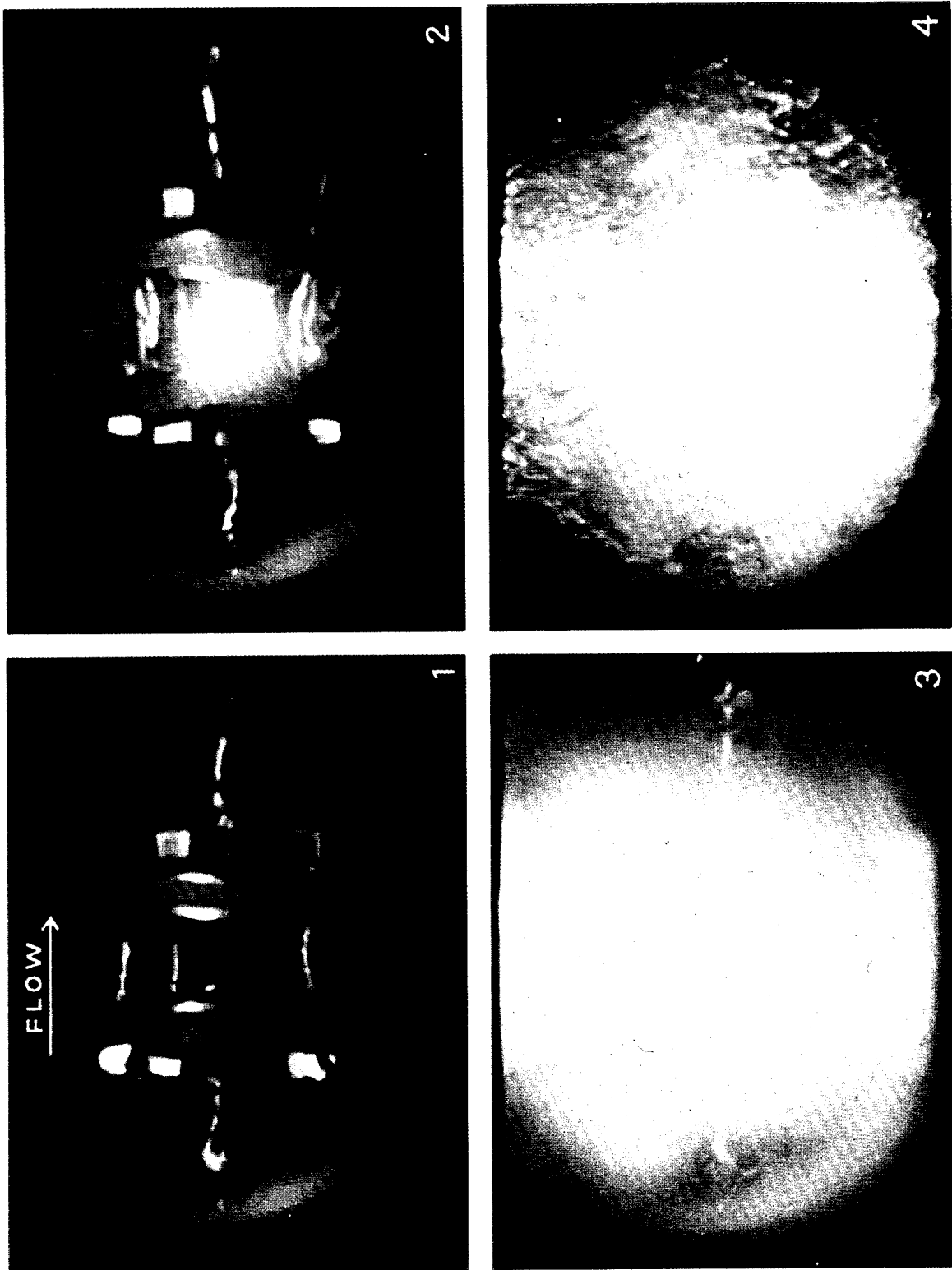
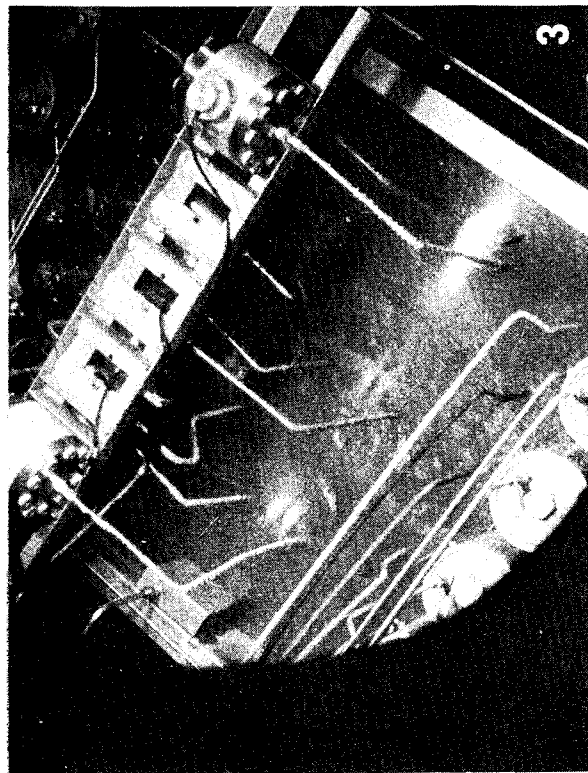
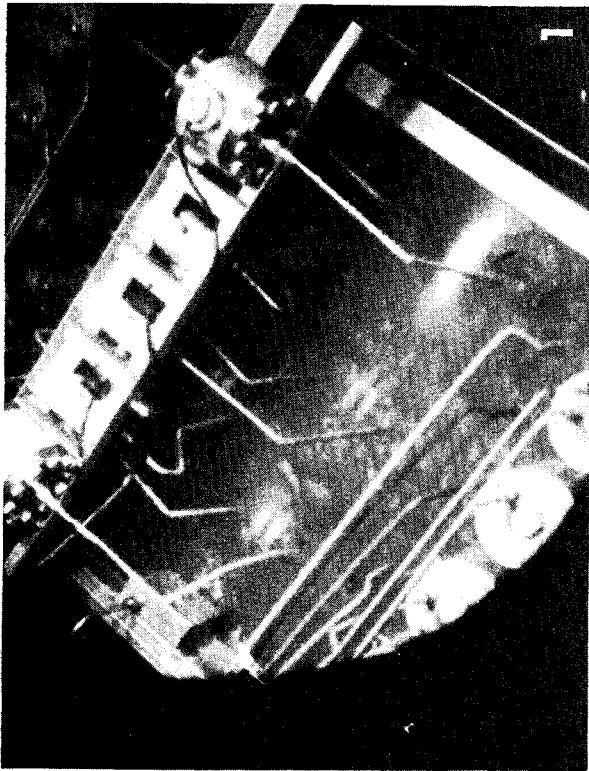
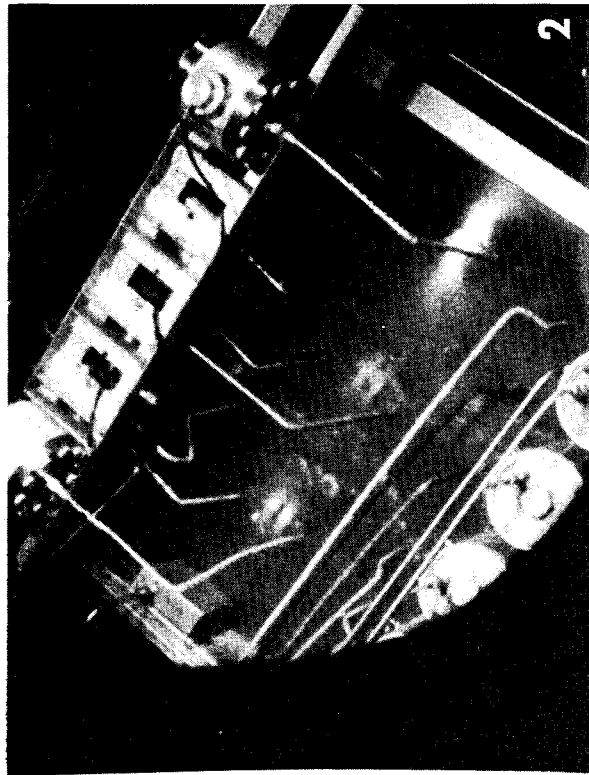
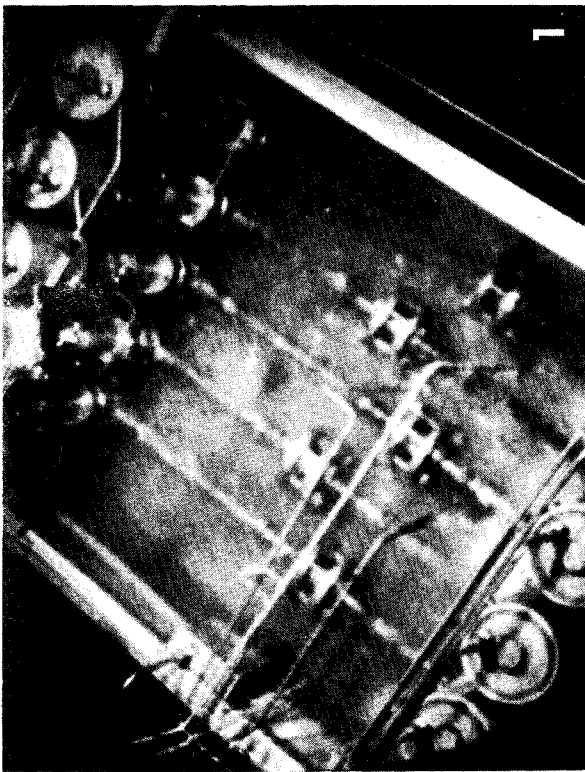

Figure 9. - Closeup view of dynamic FLOX compatibility test for Lucite. Film speed, 24 frames per second; time interval between frames 3 and 4, 9 seconds.



C-65-3603

Figure 10. - Dynamic fluorine compatibility test for Kel-F 82. Film speed, 24 frames per second.



1

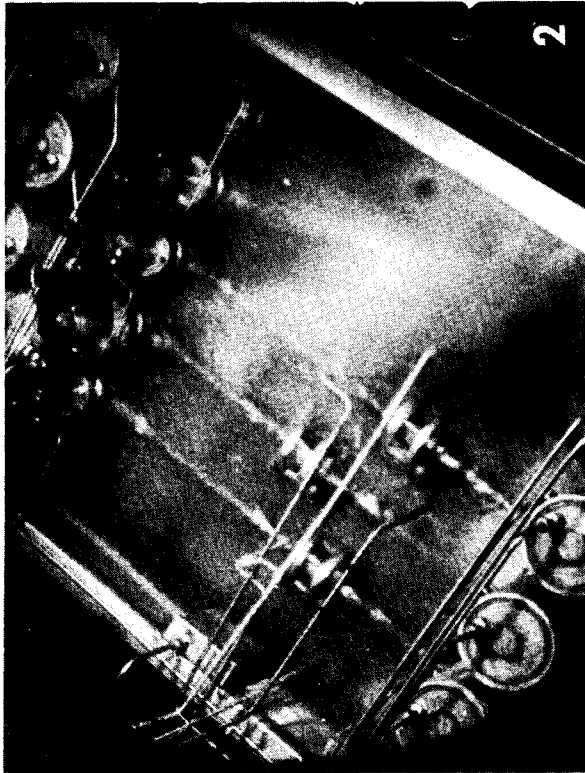

2

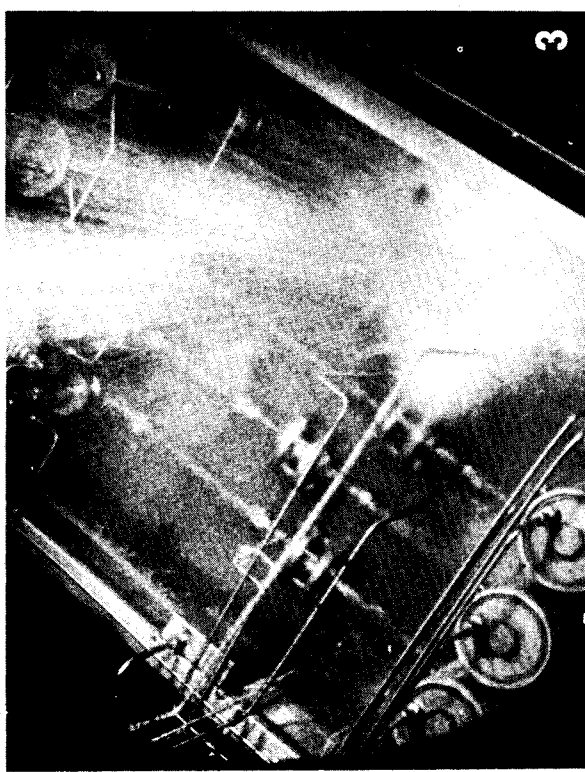

3



4

C-65-3604

Figure 11. - Dynamic fluorine compatibility test for Rulon A. Film speed, 24 frames per second.

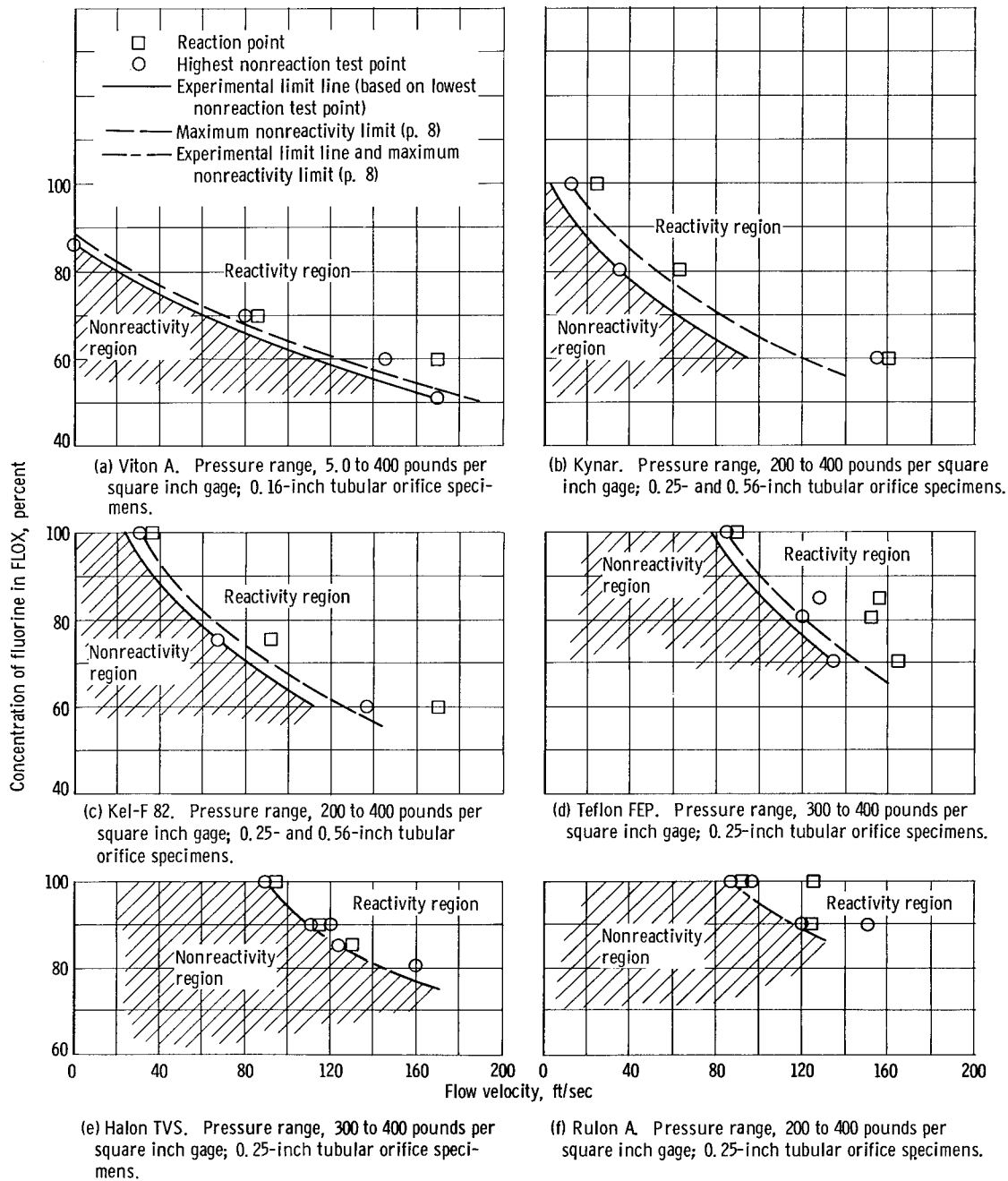

Figure 12. - Liquid FLOX reactivity profile. Test temperature,  $-320^{\circ}\text{F}$ .

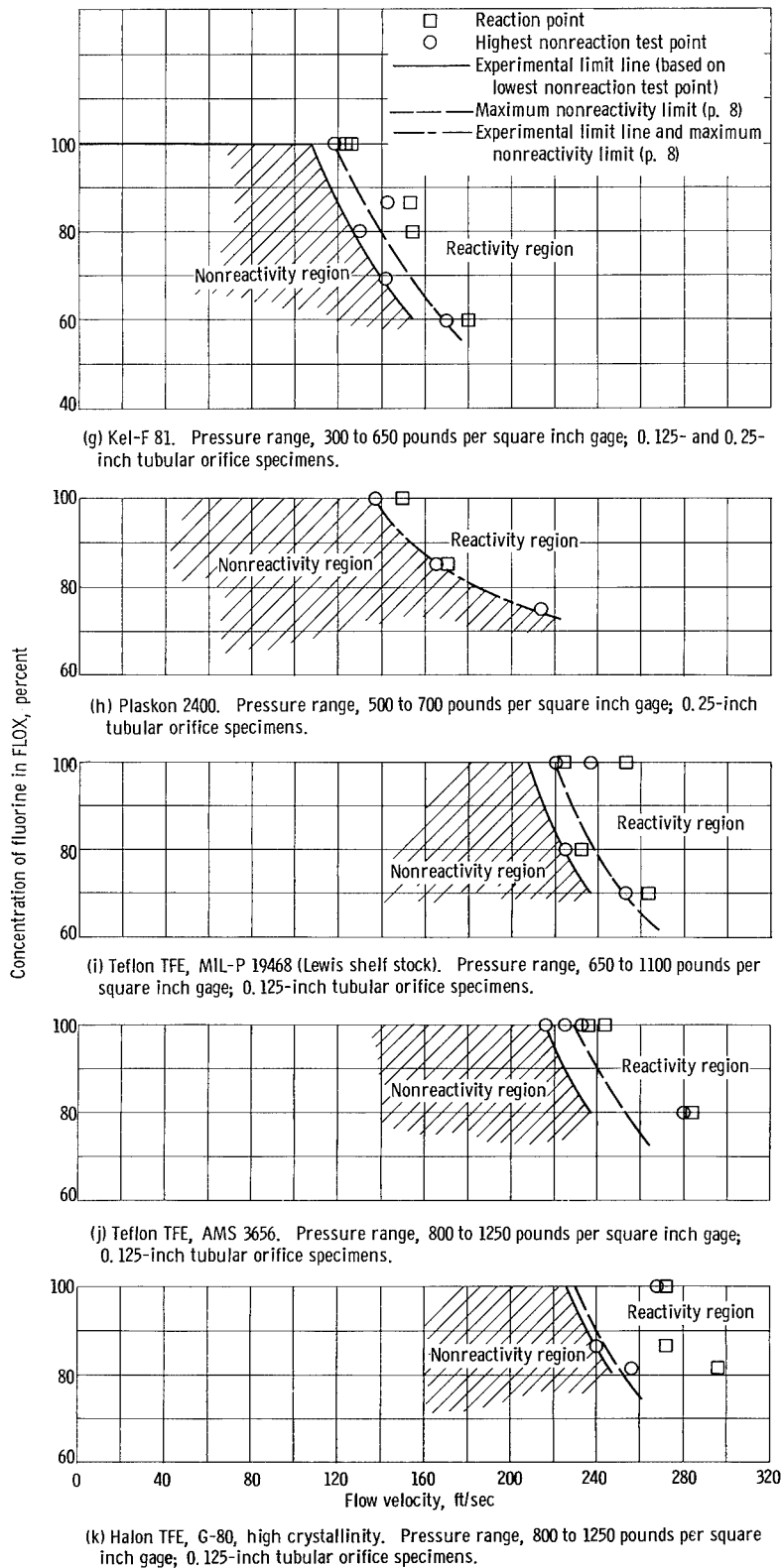

Figure 12. - Concluded.

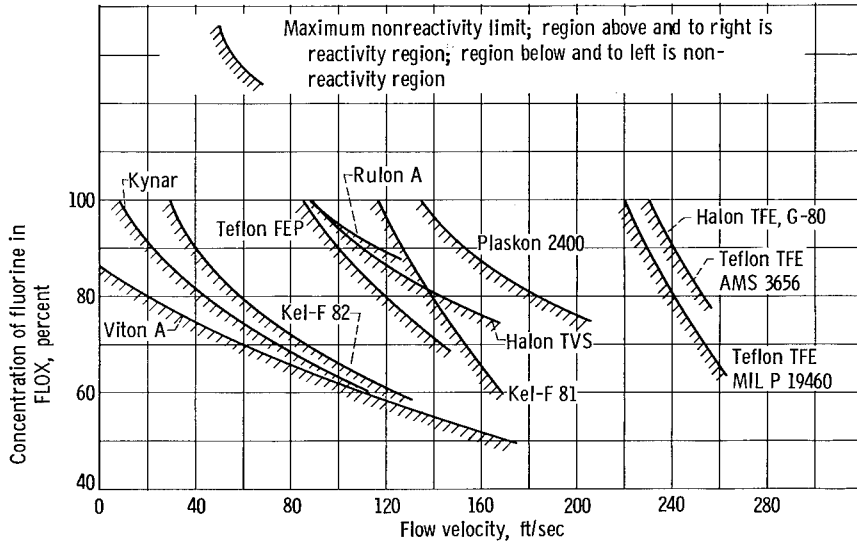

Figure 13. - Composite liquid FLOX reactivity profiles. (This composite intended for comparison purposes only; for details, see individual reactivity profiles.)

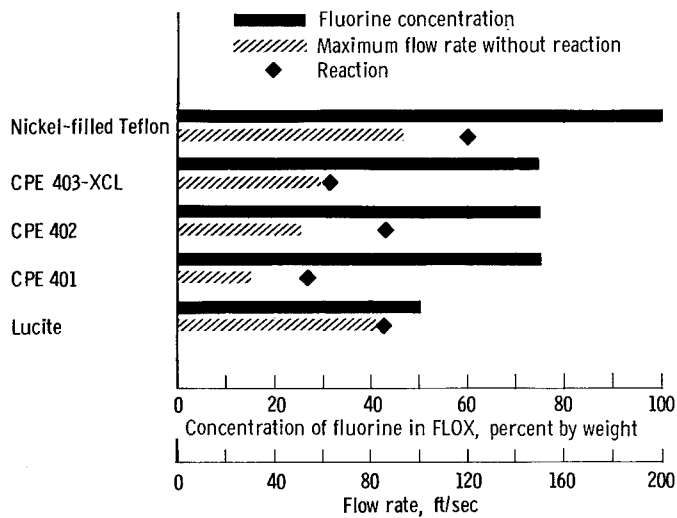

Figure 14. - Dynamic liquid FLOX compatibility tests (single data points). Pressure range, 100 to 400 pounds per square inch gage; temperature, -320° F; specimen configuration, 0.25-inch orifices.

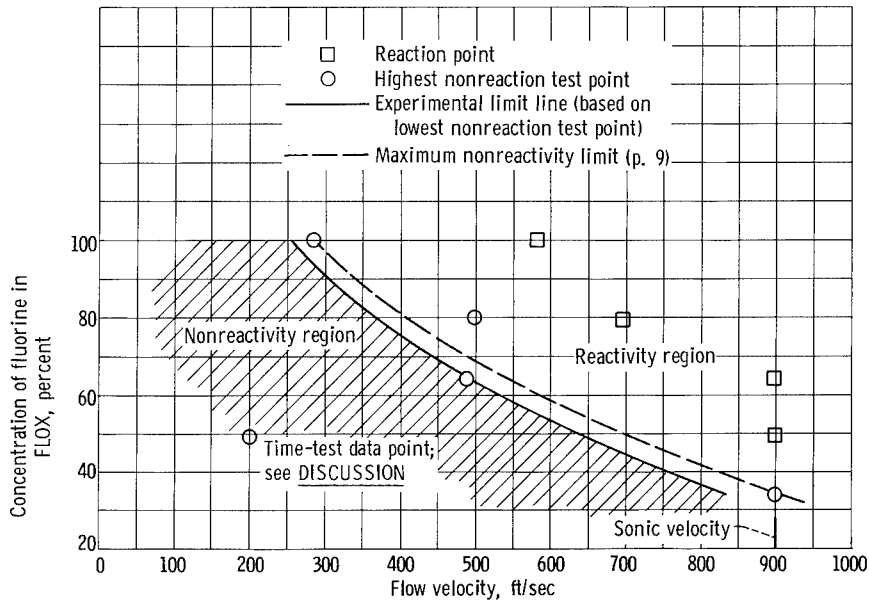

Figure 15. - Gaseous FLOX reactivity profile for Viton A. Temperature, 60° F; 0.20-inch tubular orifices.

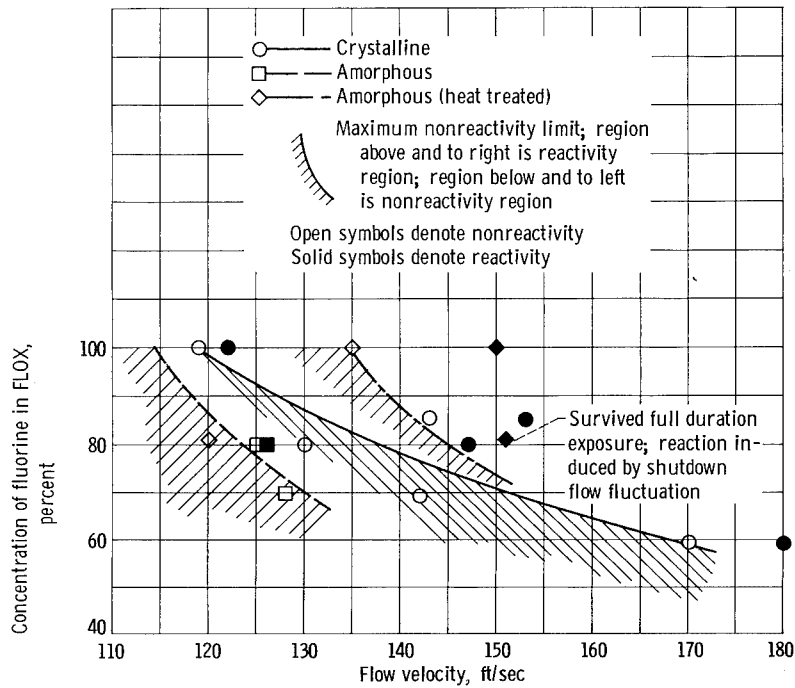
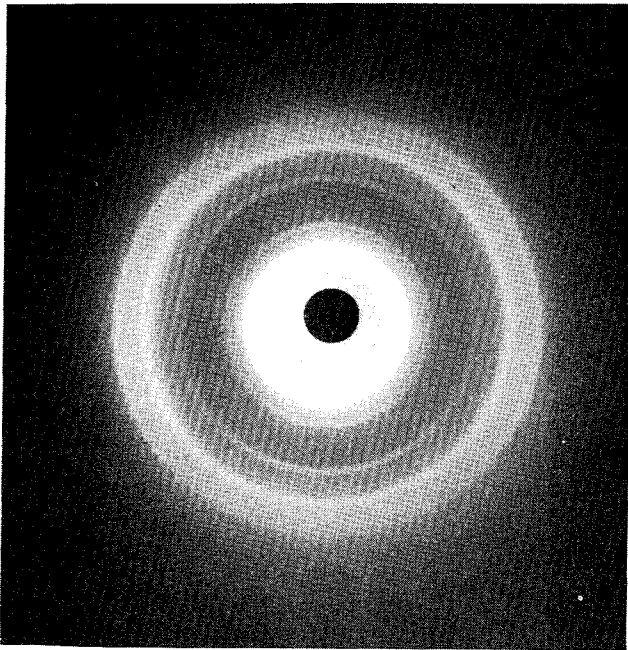
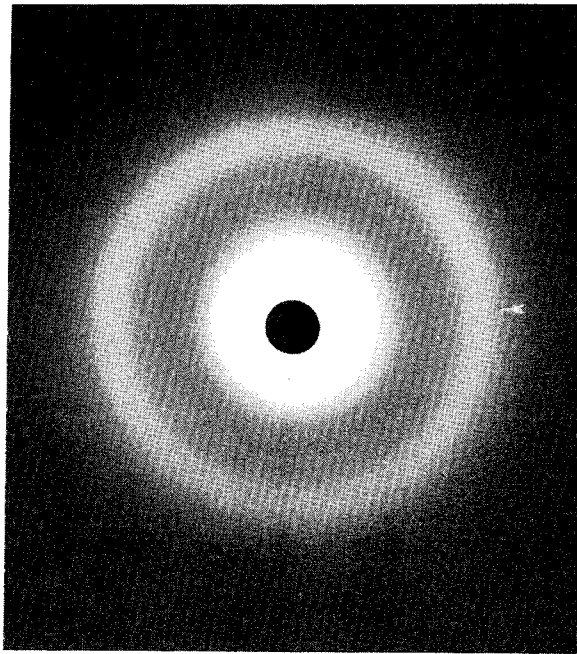

Figure 16. - Liquid FLOX compatibility profiles for crystallinity effects for Kel-F 81.



(a) Teflon TFE.



(b) Teflon FEP.

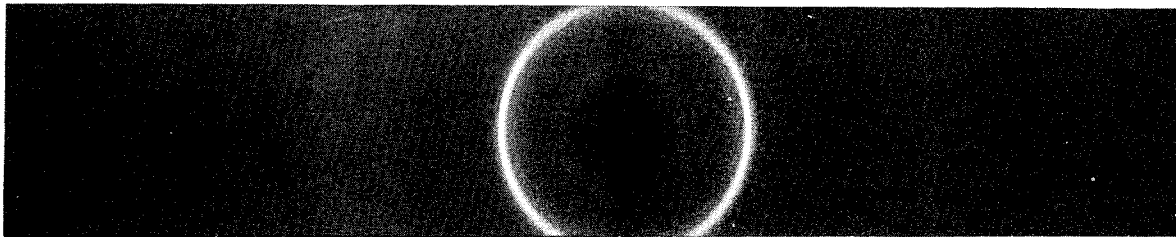

(c) Crystalline Kel-F 81.

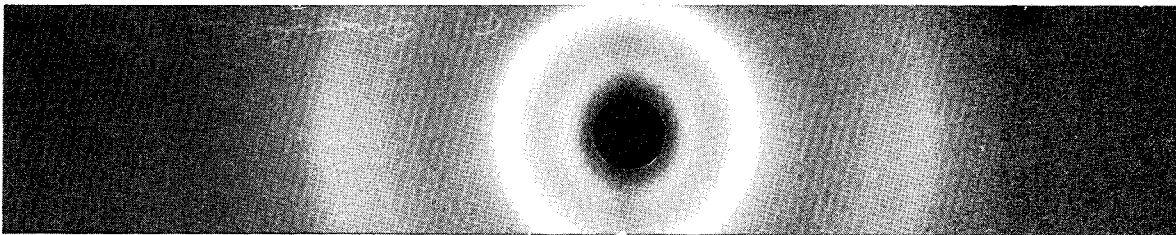

(d) Kel-F 81 amorphous.

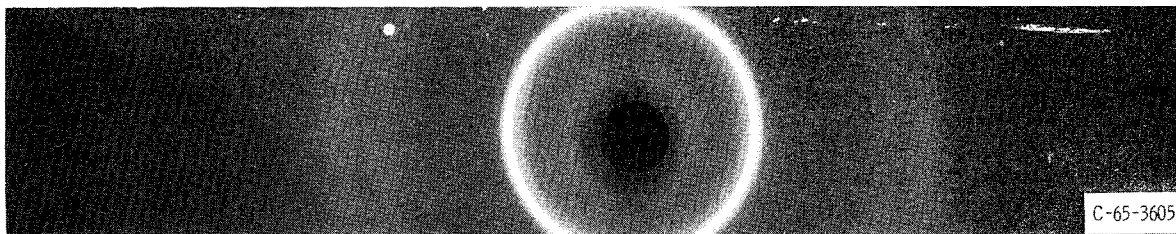

(e) Kel-F 81 amorphous (heat treated).

Figure 17. - X-ray diffraction diagrams.