

N75-15052

File
*1

1101

NASA TECHNICAL NOTE

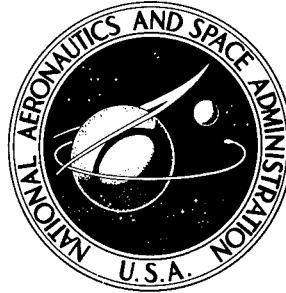

NASA TN D-7880

NASA TN D-7880

19960419 057

DYNAMIC LOAD CAPACITIES OF
GRAPHITE-FIBER - POLYIMIDE COMPOSITES
IN OSCILLATING PLAIN BEARINGS
TO 340° C (650° F)

*Harold E. Sliney, Thomas P. Jacobson,
and Harold E. Munson*

*Lewis Research Center
Cleveland, Ohio 44135*

PLASTECC



22166

NATIONAL AERONAUTICS AND SPACE ADMINISTRATION • WASHINGTON, D. C. • JANUARY 1975

DISTRIBUTION STATEMENT A
Approved for public release;
Distribution Unlimited

DTIC QUALITY INSPECTED 1

DISCLAIMER NOTICE

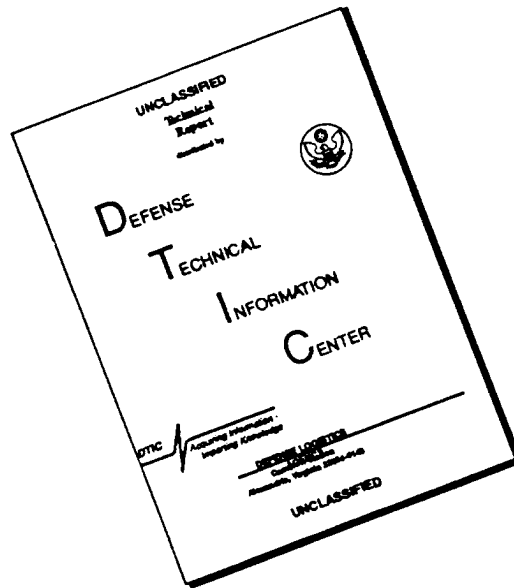

THIS DOCUMENT IS BEST QUALITY AVAILABLE. THE COPY FURNISHED TO DTIC CONTAINED A SIGNIFICANT NUMBER OF PAGES WHICH DO NOT REPRODUCE LEGIBLY.

1. Report No. NASA TN D-7880	2. Government Accession No.	3. Recipient's Catalog No.	
4. Title and Subtitle DYNAMIC LOAD CAPACITIES OF GRAPHITE-FIBER - POLYIMIDE COMPOSITES IN OSCILLATING PLAIN BEARINGS TO 340° C (650° F)		5. Report Date January 1975	
		6. Performing Organization Code	
7. Author(s) Harold E. Sliney, Thomas P. Jacobson, Lewis Research Center; and Harold E. Munson, Marlin-Rockwell Div., TRW, Inc., Jamestown, N. Y.		8. Performing Organization Report No. E-8118	
		10. Work Unit No. 505-04	
9. Performing Organization Name and Address Lewis Research Center National Aeronautics and Space Administration Cleveland, Ohio 44135		11. Contract or Grant No.	
		13. Type of Report and Period Covered Technical Note	
12. Sponsoring Agency Name and Address National Aeronautics and Space Administration Washington, D. C. 20546		14. Sponsoring Agency Code	
		15. Supplementary Notes	
16. Abstract Load capacities were determined for plain spherical bearings with self-lubricating spherical elements of graphite-fiber-reinforced-polyimide, and for plain cylindrical bearings with thin-wall liners of the composite in the bearing bores. Composites consisted of a 1-to-1 weight ratio of graphite fibers and polyimide. Oscillation was at an amplitude of $\pm 15^\circ$ at a frequency of 1 hertz. Bearings with composite ball material had a load capacity of approximately 69 MN/m^2 (10 000 psi) at room temperature and 25 MN/m^2 (3600 psi) at 340° C (650° F). Bearings with thin-wall composite liners had much higher load capacities of 280 MN/m^2 (40 000 psi) at room temperature and 240 MN/m^2 (35 000 psi) at 320° C (600° F). Friction coefficients were in the range of 0.12 to 0.19. The addition of 10 wt. % graphite fluoride solid lubricant to the composition of the thin-wall liners reduced friction coefficients into the range of 0.10 to 0.12.			
17. Key Words (Suggested by Author(s)) Airframe bearings; Space shuttle bearings; Self-lubricating composites; Self-aligning bearings; Fiber-reinforced polymers; Graphite fibers; Polyimide		18. Distribution Statement Unclassified - unlimited STAR category 37 (rev.)	
19. Security Classif. (of this report) Unclassified	20. Security Classif. (of this page) Unclassified	21. No. of Pages 16	22. Price* \$3.25

DYNAMIC LOAD CAPACITIES OF GRAPHITE-FIBER - POLYIMIDE COMPOSITES IN OSCILLATING PLAIN BEARINGS TO 340° C (650° F)

by Harold E. Sliney, Thomas P. Jacobson, and Harold E. Munson*

Lewis Research Center

SUMMARY

Load capacities were determined for plain spherical bearings with self-lubricating elements of graphite-fiber-reinforced-polyimide, and for plain cylindrical bearings with thin-wall liners of the composite in the bearing bores. Composites consisted of a 1-to-1 weight ratio of graphite fibers and polyimide. Oscillation was at an amplitude of $\pm 15^\circ$ at a frequency of 1 hertz. Bearings with composite ball material had a load capacity of approximately 69 MN/m^2 (10 000 psi) at room temperature and 25 MN/m^2 (3600 psi) at 340° C (650° F). Bearings with thin-wall composite liners had much higher load capacities of 280 MN/m^2 (40 000 psi) at room temperature and 240 MN/m^2 (35 000 psi) at 320° C (600° F). Friction coefficients were in the range of 0.12 to 0.19. The addition of 10 wt. % graphite fluoride solid lubricant to the composition of the thin-wall liners reduced friction coefficients into the range of 0.10 to 0.12.

INTRODUCTION

Plain spherical bearings (also known as rod end bearings) are used in applications requiring oscillating motion and self-aligning capability. Aerospace applications include airframe bearings and bearings for engine control linkages. Airframe control surface bearings are a particularly difficult application because of the requirement for exceptionally high dynamic load capacity. Further, aerodynamic heating in supersonic flight, especially at speeds of Mach 3 or higher, will heat control surface bearings above the 163° C (325° F) service limit for reinforced polytetrafluorethylene (PTFE)-lined bearings currently used in many aircraft.

An alternative to PTFE is the family of high-temperature polyimide polymers. Some of these polyimides retain good mechanical strength for at least 1000 hours at

* Marlin-Rockwell Division, TRW, Inc., Jamestown, New York.

260° C (500° F) and for over 200 hours at 320° C (600° F) (refs. 1 and 2). It has also been demonstrated by investigators including Giltrow and Lancaster that graphite-fiber-reinforced-polyimide has good friction and wear characteristics (refs. 3 and 4).

A preliminary study of oscillating bearings, which were self-lubricated with graphite-fiber-reinforced-polyimide composite, was performed in this laboratory (ref. 5). Bearings were tested from 24° to 340° C (75° to 650° F) at unit loads up to 35 MN/m² (5000 psi). Composites with various fiber contents were studied. Promising results were obtained with an approximately 1-to-1 fiber to resin ratio.

The purpose of the research described in the present report was to determine the dynamic load capacities of self-aligning plain spherical and plain cylindrical oscillating bearings with molded graphite-fiber-polyimide self-lubricating elements. The composition selected for this study was 50 wt. % chopped graphite fibers - 50 wt. % polyimide.

Three bearing designs were evaluated. In two of these, the self-lubricating composite was a structural component of the bearing, the spherical element. The other design was a cylindrical bearing with a thin-wall composite liner in the bore.

Experiments were designed to show whether the unsupported composite has a useful load capacity and to determine the increase in load capacity possible when the composite is constrained by a rigid metal backing. Dynamic load capacities were determined in step load tests at room temperature, 320° and 340° C (600° and 650° F).

BEARING MATERIALS AND DESIGNS

The resin used in the composite bearing material is a so-called addition-type polyimide which is described in reference 6. Addition polymers consolidate during a final cure by a polymerization reaction which does not release volatile reaction products. The more conventional condensation-type polyimides consolidate during the cure by a reaction which releases large volumes of volatile matter, predominantly water vapor. The necessity of disposing of volatiles makes it difficult to achieve a dense, cured polymer body without a large number of voids. The addition-type polymer was therefore used in order to avoid this problem.

The graphite is in the form of chopped fibers 6.4×10^{-3} meter (1/4 in.) long, with an equivalent diameter of 7.6×10^{-6} meter (0.0003 in.) and a specific gravity of 1.4. The fibers have a tensile strength of 600 MN/m² (90 000 psi). The composite has a yield strength of about 200 MN/m² (30 000 psi) and an elastic modulus of 4.4 GN/m² (640 000 psi).

The outer races and the journal are made of 440-C-HT steel hardened to Rockwell C-60. This alloy has a hot hardness of Rockwell C-57 at 340° C (650° F) and had good oxidation resistance in air to about 540° C (1000° F). The sliding surfaces are ground to a 10^{-7} -m (4- μ in.) rms finish.

The three test bearing designs are illustrated in figure 1. In figures 1(a) and (b) the spherical elements of the bearings are molded composites of graphite-fiber-reinforced-polyimide resin with 50 wt. % fiber. In design 1, the bearing is free to turn on either its journal or on the ball o. d. , the shorter moment arm to the journal surface results in lower torque for motion at the journal, therefore, oscillation is predominantly on the journal with some creeping possible on the ball o. d. With this mounting method, the bearing is essentially a self-aligning plain cylindrical bearing. Design 2 has a 440-C-HT liner in the bore of the ball; the ball is clamped to the journal and all relative motion is limited to the interface between the ball o. d. and the outer race. In both designs, the spherical o. d. of the ball permits the bearing to accept misalignment.

Design 3 is not intended to be a practical bearing. It is merely a convenient arrangement for testing thin-wall composite liners at high unit loads. The design consists of a small steel bushing with a thin-wall composite liner (0.64 cm (1/4 in.) bore and length and 0.16 cm (1/16 in.) thickness) which is mounted in the bore of a larger spherical bearing. The assembly is basically a small cylindrical bearing utilizing the spherical bearing as a self-aligning mounting.

Unit loads are defined here in the conventional manner as the radial load per unit of projected area of the sliding surfaces. The projected area for journal oscillation in the bearing bore is the product of the bore length and diameter; for ball oscillation in the outer race, it is the product of the ball diameter and the width of the outer race. The sliding surfaces, bearing clearances, and dimensions relevant to calculating unit loads are given in table I. Figure 2 gives unit loads as a function of total load for the three different bearing designs.

BEARING TEST MACHINE AND PROCEDURE

Two bearing test machines were used. The first machine (fig. 3) was fully described in reference 5. It is capable of testing bearings at radial loads up to about 1.3×10^4 N (3000 lb), and it was used to test the small bore bearings of design 3. The other machine (fig. 4) was capable of bearing loads up to about 3.6×10^4 N (8000 lb) and was used to determine load capacities of bearing designs 1 and 2.

The second machine mounts two bearings in pressure contact against a reciprocating friction drive. By adjusting the stroke of the drive rod, the desired amplitude of angular oscillation can be achieved in the test bearings. Reciprocating motion is provided by a crank mechanism and has a frequency range of 0.4 to 4 hertz. Bearing torque is measured by means of strain gages in a load cell that is mounted directly in the reciprocating drive rod. Two bearings are loaded against each other by dead weights acting through a compound lever system with a 187 to 1 mechanical advantage.

High-temperature capabilities are provided by an enclosing oven capable of temperatures up to 650° C (1200° F). Bearing torque and temperature are continuously recorded.

Bearing radial wear is indicated during the tests by means of dial gages suitably mounted on the test machines. The dial gages indicate any changes in the eccentricity of the bearing. Changes in dial gage readings are used as an indication of wear only during bearing operation at constant load and temperature in order to minimize errors caused by load or thermal deflections in the test machine.

The bearing test conditions were: oscillation of 1 hertz and a $\pm 15^\circ$ amplitude; temperatures of no external heat addition, 320° C (600° F), and 340° C (650° F); step loads increasing in increments of 2200 N (500 lb) at intervals of 10 minutes; duration, until the bearing failed.

The failure load is here defined as either the load at which the composite bearing material fractured or the load at which a disproportionate increase in wear rate ensued. Fracture was detected as a sudden increase in bearing eccentricity and excessive wear was detected as a continuous but disproportionately rapid increase in bearing eccentricity.

RESULTS AND DISCUSSION

Friction

Friction coefficients, which were calculated from bearing torque, are given in figures 5, 6, and 8 as a function of radial unit load at room temperature and at 340° C (650° F).

Figure 5 relates to bearing design 1 in which the ball is made of polyimide composite and oscillation occurs at the journal/bore interface. Friction coefficients in the room temperature experiments tended to decrease with increasing load and reached a minimum at about 41 MN/m² (6000 psi) then gradually increased until the balls fractured. The same general trend occurred in the 340° C (650° F) experiments but fracture occurred at lighter loads.

Figure 6 relates to bearing design 2 in which the ball is made of polyimide composite, but the bore is reinforced with a cylindrical steel bushing and oscillation occurs at the ball/outer race interface. Here, again, friction coefficients at room temperature decreased with load but became constant above 34 MN/m² (5000 psi).

The term room temperature experiment indicates that no furnace heat was supplied to the bearings. Actual bearing temperatures resulting from frictional heat generation are given in figure 7 as a function of radial load for bearing designs 1 and 2.

Figure 8 gives the friction coefficients for the thin-walled polyimide composite bushings (bearing 3). Friction coefficients were in the range of 0.12 to 0.19 at all loads and both temperatures (room and 320° C (600° F)).

The addition of 10 wt. % graphite fluoride (CF_x) to the composition reduced friction coefficients. At room temperature the friction coefficient was a constant 0.10 at all loads; at 320° C (600° F), friction coefficients were 0.10 to 0.12 at all loads.

Load Capacities

As previously described, bearing dynamic load capacities were determined by progressively increasing the radial load on the test bearing until the polyimide composite fractured or a large disproportionate increase in wear rate occurred.

As might be expected intuitively and from strength of materials consideration (ref. 7), the load capacities of bearings with thin composite liners were much higher than those with composite ball material. However, the data indicate that even the polyimide composite balls can carry useful loads.

The load capacities are summarized in table II and figure 9. The load capacities of bearings with polyimide composite balls were over 69 MN/m² (10 000 psi) at room temperature and above 25 MN/m² (3600 psi) at 340° C (650° F).

In design 1, the bearings failed, at their limiting load, by fracture of the composite ball. A failed bearing of this design is shown in figure 10. The sliding surfaces in the bore generally appeared to be in good condition. Failure was initiated by cracking then fracture of the ball along the contact between the edges of the outer race and the ball.

In design 2, failure did not generally occur by gross fracture, but at the limiting load, severe wear of the sliding surface of the ball was observed. This is shown in figure 11. The steel bore insert apparently was effective in preventing gross fracture of the ball. Before the limiting load was reached, the sliding surface of the ball was in good condition, but some roughening that appeared to be small-scale spalling was observed just outside the race contact area. This type of damage can also be seen on the bearing in figure 11.

Design 3 had by far the highest load carrying capacities: 280 MN/m² (40 000 psi) at room temperature and 240 MN/m² (35 000 psi) at 320° C (600° F). These values meet or exceed the room temperature load capacity requirements in the military specifications MIL B 81820-A for PTFE-lined airframe control surface bearings (ref. 8). The load capacity of PTFE-lined bearings decreases rapidly above 160° C (325° F) while the polyimide-lined bearings retain load capacity in excess of 240 MN/m² (35 000 psi) to at least 320° C (600° F).

Friction heat generation can be a factor in limiting the load capacity of sliding bear-

ings. Low friction coefficients are therefore desirable, not only for minimizing bearing torque, but also to minimize heat generation. As indicated earlier, the addition of 10 wt. % graphite fluoride $(CF_x)_n$ solid lubricant to the polyimide composite liners resulted in a significant decrease in friction coefficients (fig. 8). However, there was a moderate loss of load capacity in spite of the reduced heat generation. Therefore, a trade-off exists in which the solid lubricant addition provides a desirable reduction in bearing torque but results in a small reduction (less than 10 percent) in load capacity. These observations (in addition to the observation that the composites never appeared to have undergone thermal degradation in any of the tests) tends to indicate that the ultimate limiting factors in the load capacities of these bearings involve mechanical strength rather than thermal effects at the sliding velocities used.

The load-capacity determinations were made on comparatively small polyimide composite liners in order to achieve high unit loads with the available bearing test machine which has a maximum radial load capability of 1.3×10^4 N (3000 lb). The small composite liner is shown in figure 12.

The results with the small cylindrical liners are favorable, but it will be prudent to determine load capacities of larger bearings with polyimide liners in order to enable reliable predictions of load capacities over a range of bearing sizes.

SUMMARY OF RESULTS

Load capacities were determined for plain bearings with self-lubricating elements of graphite-fiber-reinforced-polyimide. The composite was evaluated as a ball material and as a thin-wall bearing liner material. Composites consisted of a 1-to-1 weight ratio of graphite fibers and polyimide. Dynamic load capacity tests consisted of step-wise increases in radial load at about 2200 N (500 lb) increments until bearing structural failure or a large and disproportionate increase in wear rate occurred. Oscillation frequency was 1 hertz at $\pm 15^\circ$ amplitude. Temperatures were: no external heat addition (nominal room temperature), 320° C (600° F), and 340° C (650° F).

The principal results were as follows:

1. Dynamic load capacities of 280 MN/m^2 (40 000 psi) at nominal room temperature and 240 MN/m^2 (35 000 psi) at 320° C (600° F) were achieved in cylindrical steel bearings with thin-wall, graphite-fiber-reinforced-polyimide liners. Friction coefficients were reduced by about 30 percent (typically from 0.15 to 0.10) at the cost of a small reduction in load capacity by the addition of 10 wt. % graphite fluoride $(CF_x)_n$ to the composite formulation.

2. Plain spherical bearings, with spherical elements made of the composite, had a load capacity of about 69 MN/m^2 (10 000 psi) at room temperature and 25 MN/m^2

(3600 psi) at 340° C (650° F).

3. The previous results demonstrate that oscillating bearings employing thin-wall graphite-fiber-polyimide liners should be useful in very high load, low speed applications such as aircraft control surface bearings to temperatures of at least 320° C (600° F). For light-to-moderate load applications, the molded composite may be used as the ball material in plain spherical bearings.

Lewis Research Center,
National Aeronautics and Space Administration,
Cleveland, Ohio, November 11, 1974,
505-04.

REFERENCES

1. Browning, C. E.; and Marshall, J. R., II: Graphite Fiber Reinforced Polyimide Composites. *J. Composite Mat.*, vol. 4, no. 3, July 1970, pp. 390-403.
2. Hanson, M. P.; and Serafini, T. T.: Effects of Thermal and Environmental Exposure on the Mechanical Properties of Graphite/Polyimide Composites. NASA TN D-6604, 1972.
3. Giltrow, G. P.: The Influence of Temperature on the Wear of Carbon Fiber Reinforced Resins. *ASLE Trans.*, vol. 16, no. 2, April 1973, pp. 83-90.
4. Giltrow, J. P.; and Lancaster, J. K.: Friction and Wear of Polymers Reinforced with Carbon Fiber. *Nature*, vol. 214, no. 5093, 1967, p. 1106.
5. Sliney, H. E.; and Johnson, R. L.: Graphite-Fiber-Polyimide Composites for Spherical Bearings to 340° C (650° F). NASA TN D-7078, 1972.
6. Delvigs, Peter; Serafini, Tito T.; and Lightsey, George R.: Addition-Type Polyimides from Solutions of Monomeric Reactants. NASA TN D-6877, 1972.
7. Collings, T. A.: Transverse Compressive Behavior of Unidirectional Carbon Fibre Reinforced Plastics. *Composites*, vol. 5, no. 3, May 1974, pp. 108-116.
8. Military Specification, Bearings, Plain, Self-Lubricating, Self-Aligning, Low Speed. MIL B-81820, Dept. Defense, Mar. 31, 1972.

TABLE I. - BEARING SLIDING CONTACT DIMENSIONS

Bearing characteristic	Design 1	Design 2	Design 3
Sliding interface	Journal/bore	Ball o. d. /outer race	Journal/bore
Clearance, cm (in.)	0.0038 (0.0015)	0.0038 (0.0015)	0.0025 (0.0010)
Diameter, cm (in.)	1.591 (0.6265)	2.924 (1.151)	0.6353 (0.2501)
Length, cm (in.)	1.91 (0.75)	1.40 (0.55)	0.64 (0.25)
Projected area, cm ² (in. ²)	3.03 (0.47)	1.60 (0.63)	0.16 (0.063)

TABLE II. - INDIVIDUAL RESULTS OF DYNAMIC
LOAD CAPACITY TESTS

Temperature	Limiting load	
	MN/m ²	psi
Design 1		
Room temperature	74	11 000
	74	11 000
340 ^o C (650 ^o F)	25	3 600
	25	3 600
	44	6 400
Design 2		
Room temperature	74	11 000
	74	11 000
	69	10 000
340 ^o C (650 ^o F)	33	4 800
Design 3		
Room temperature	280	40 000
320 ^o C (600 ^o F)	240	35 000
Design 3 with 10 wt. % (CF _x) _n additive in composite		
Room temperature	260	37 500
320 ^o C (600 ^o F)	220	32 500

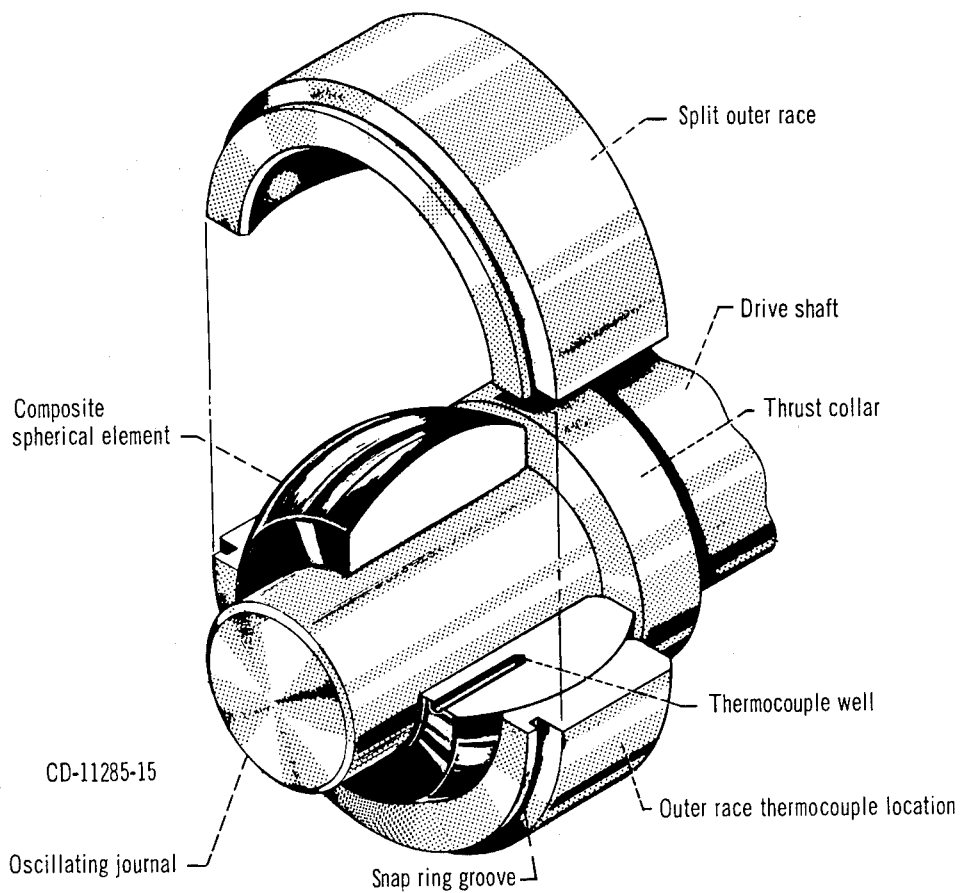

(a) Design 1; molded composite ball. Journal oscillates in bearing bore.

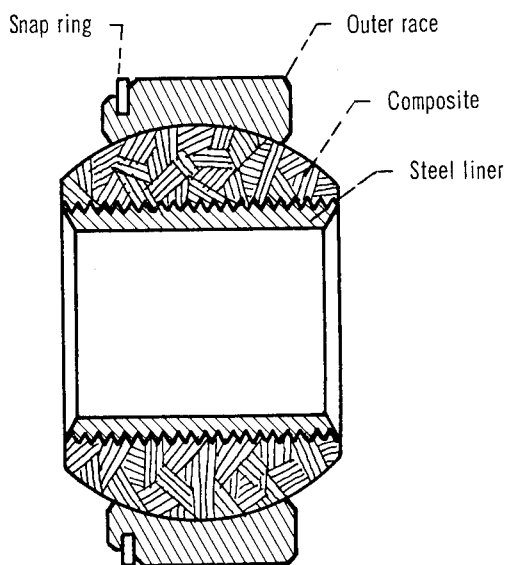

(b) Design 2; molded composite ball with steel-reinforced bore. Ball oscillates in outer race.

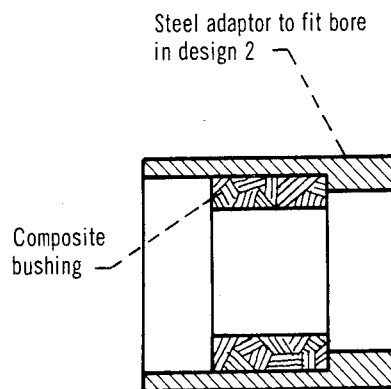

(c) Design 3; composite bushing and adaptor to allow testing to high unit loads. Journal oscillates in bore of bushing.

Figure 1. - Experimental bearing configurations.

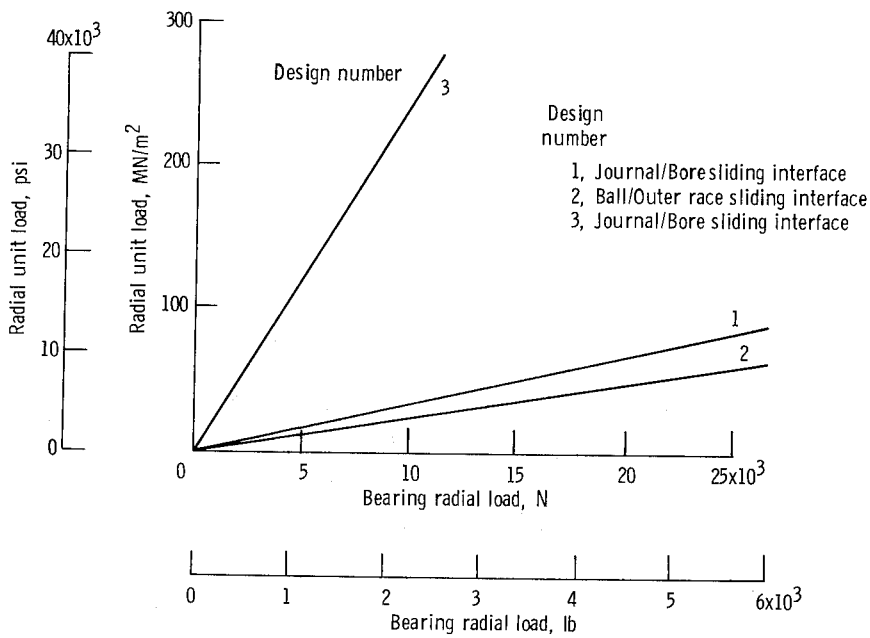

Figure 2. - Unit loads at sliding surface as a function of total radial load for three bearing designs used in this study.

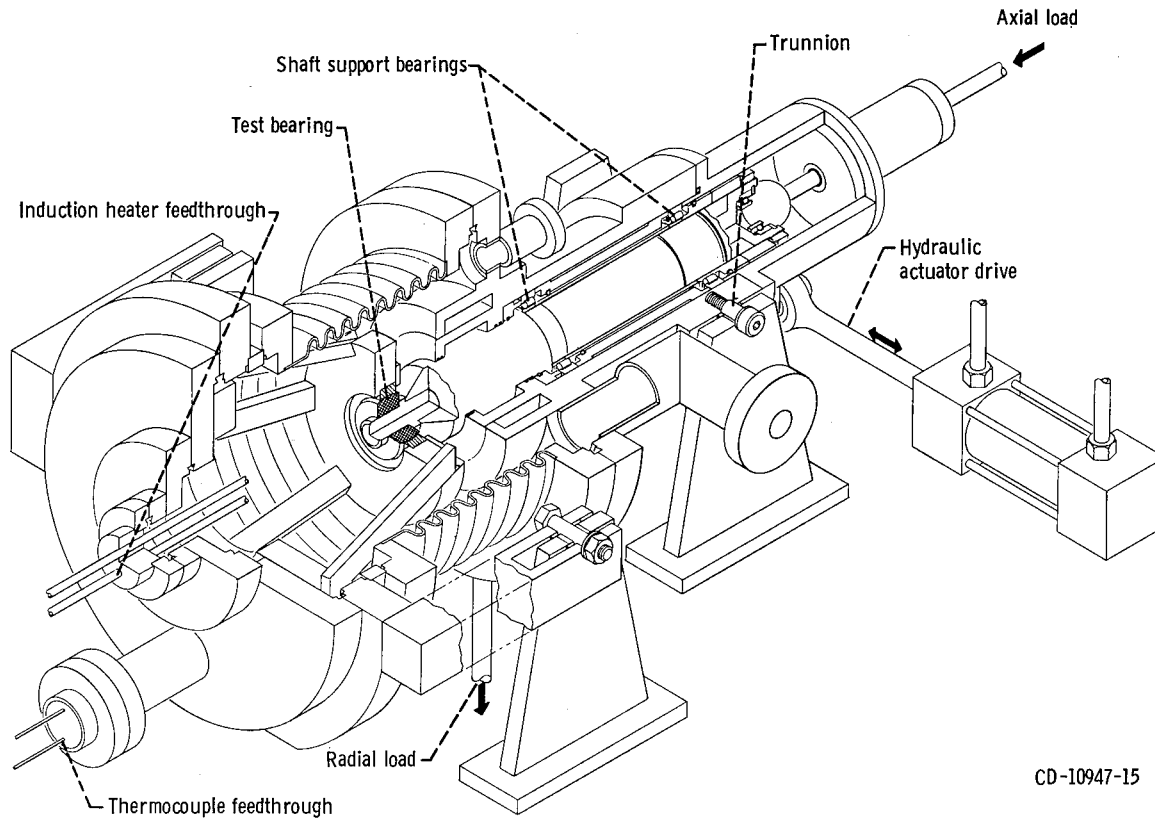

Figure 3. - High-temperature oscillating bearing test rig.

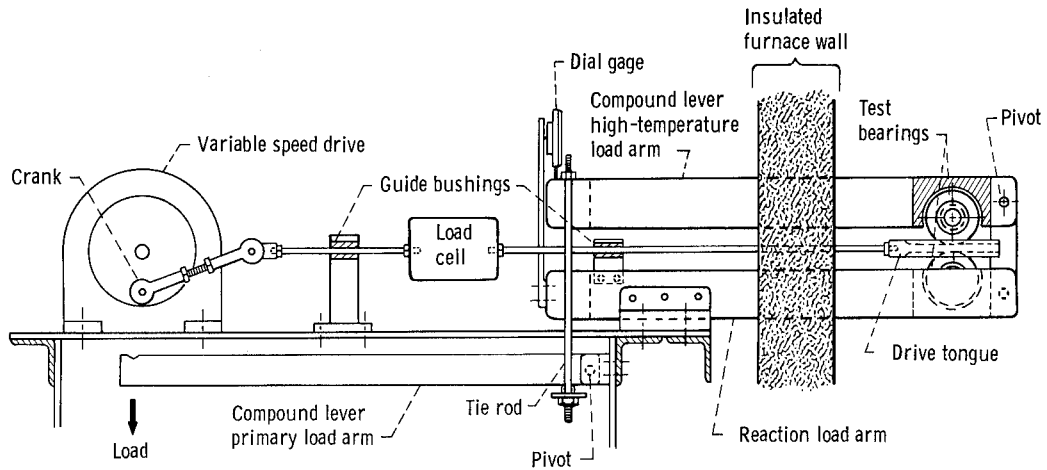

Figure 4. - High-temperature oscillating bearing test rig (high load capability).

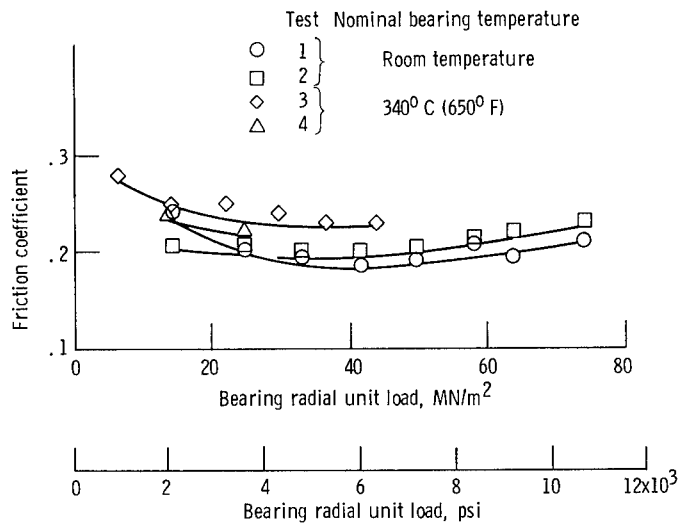

Figure 5. - Friction for journal/bore sliding contact (polyimide composite ball) design 1. Oscillation frequency at $\pm 15^\circ$ amplitude, 1 hertz.

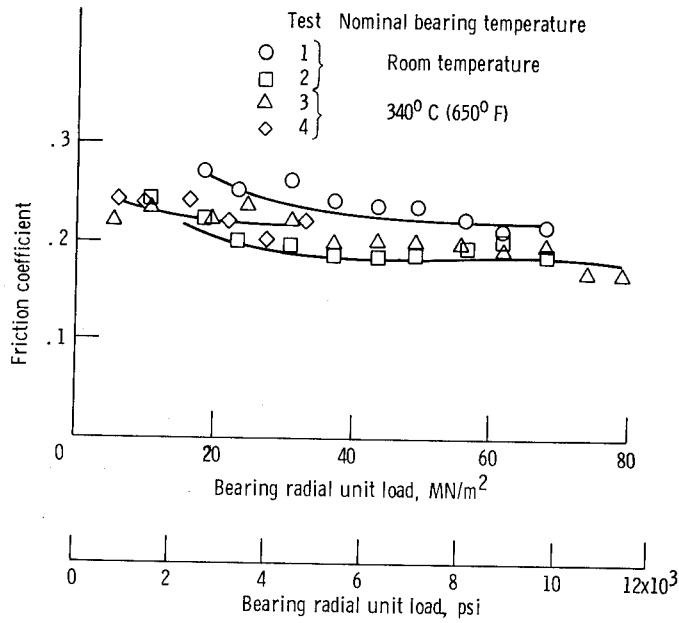

Figure 6. - Friction for ball/outer race sliding contact (polyimide composite ball with steel bore) design 2. Oscillation frequency at $\pm 15^\circ$ amplitude, 1 hertz.

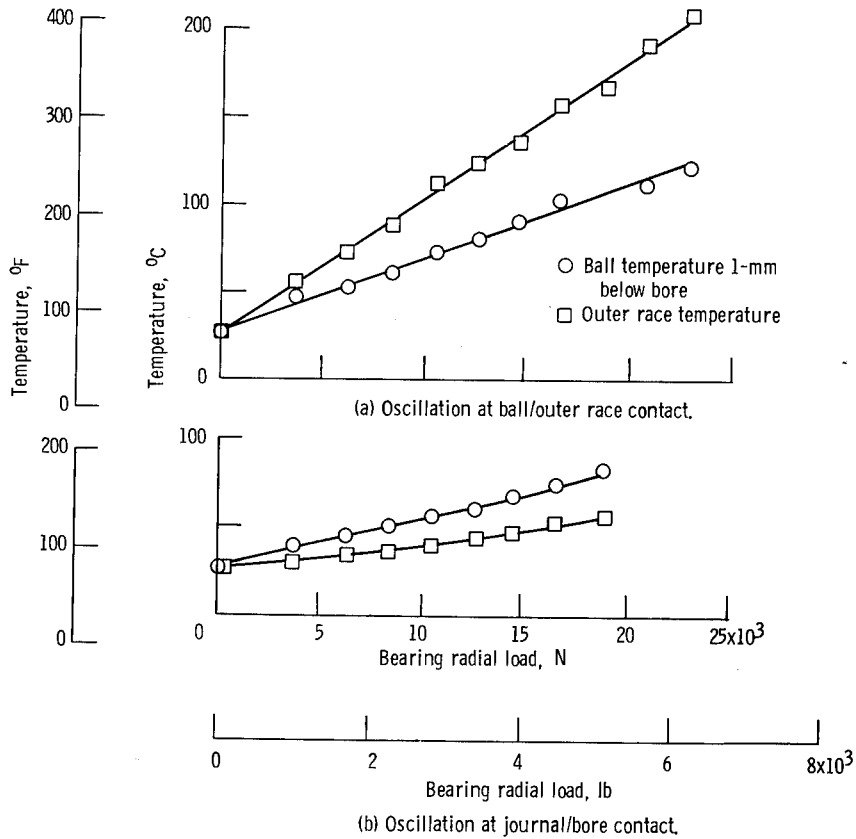

Figure 7. - Friction-induced bearing temperatures for two methods of bearing mounting. Nominal room temperature tests; oscillation frequency at $\pm 15^\circ$ amplitude, 1 hertz.

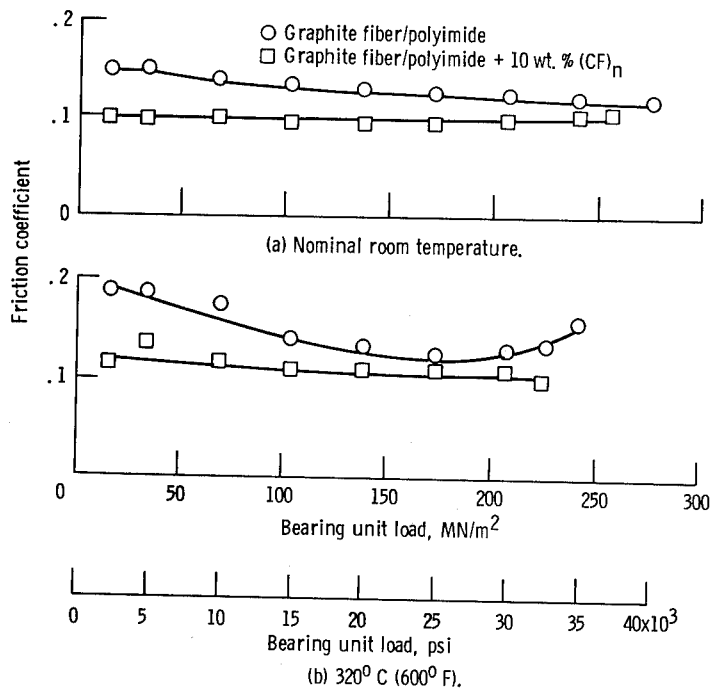

Figure 8. - Influence of (CF)_n addition on friction of bearings with thin-wall polyimide composite liner in cylindrical bore. Oscillation frequency at ±15° amplitude, 1 hertz.

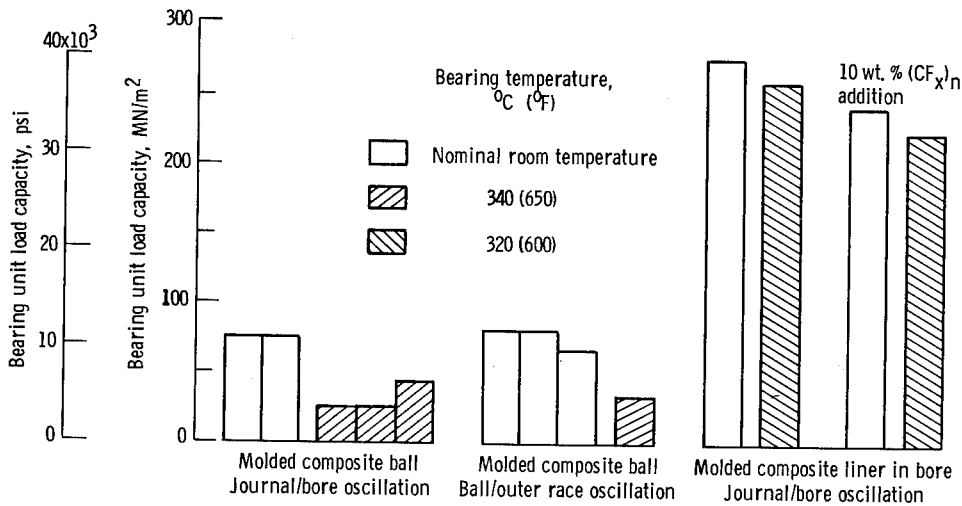
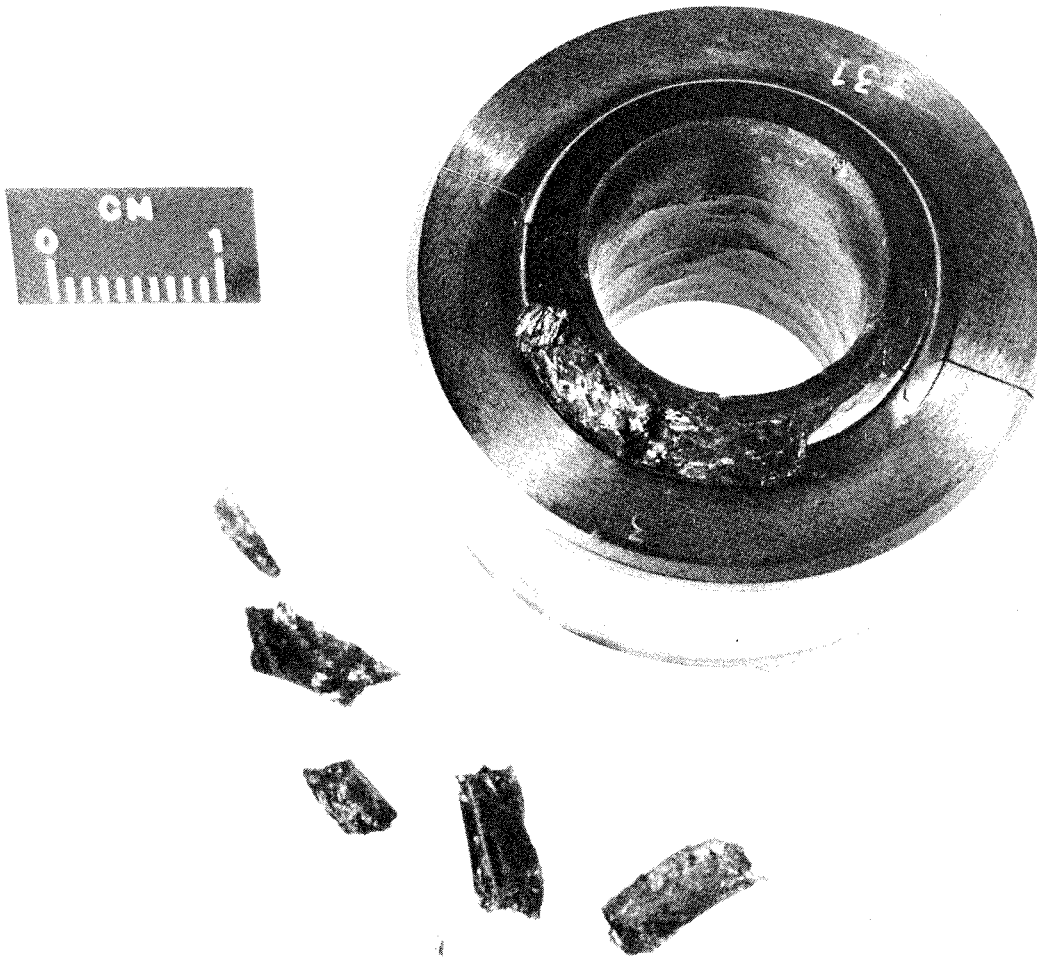

Figure 9. - Unit load capacities of three bearing designs with graphite-fiber - polyimide composite self-lubricating elements. Capacities determined during oscillation frequencies of 1 hertz at ±15° amplitude.



C-74-2011

Figure 10. - Fracture failure of design 1 bearing subjected to load capacity test.



C-74-2012

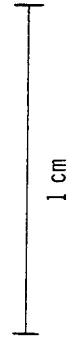
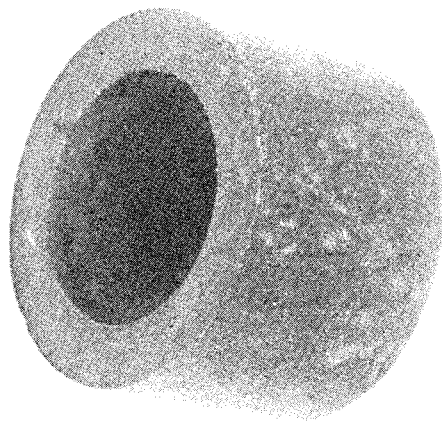

Figure 11. - Scoring failure of design 2 bearing subjected to load capacity test.



C-74-2008

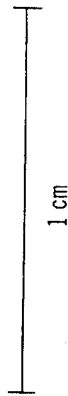

Figure 12. - Small composite liner used in design 3 bearings (6.4- by 6.4-mm bore, 1.6-mm wall).