

WL-TR-96-4037

INTELLIGENT PROCESS CONTROL FOR
PULSED-LASER DEPOSITION



JAMES A. GREER

PVD PRODUCTS, INC.
35 CABOT ROAD
WOBURN MA 01801-1003

DECEMBER 1995

FINAL REPORT FOR 05/05/95-11/05/95

APPROVED FOR PUBLIC RELEASE; DISTRIBUTION IS UNLIMITED.

19960422 026

MATERIALS DIRECTORATE
WRIGHT LABORATORY
AIR FORCE MATERIEL COMMAND
WRIGHT PATTERSON AFB OH 45433-7734

EXES QUALITY INSPECTED 1

NOTICE

When Government drawings, specifications, or other data are used for any purpose other than in connection with a definitely Government-related procurement operation, the United States Government incurs no responsibility or any obligation whatsoever. The fact that the government may have formulated or in any way supplied the said drawings, specifications, or other data, is not to be regarded by implication, or otherwise in any manner construed, as licensing the holder, or any other person or corporation; or as conveying any rights or permission to manufacture, use, or sell any patented invention that may in any way be related thereto.

This report has been reviewed by the Office of Public Affairs (ASC/PA) and is releasable to the National Technical Information Service (NTIS). At NITS, it will be available to the general public, including foreign nations.

This technical report has been reviewed and is approved for publication.

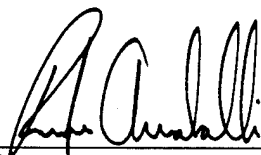

LT. RONJON ANNABALLI
Materials Process Design Branch
Integration and Operations Division
Materials Directorate

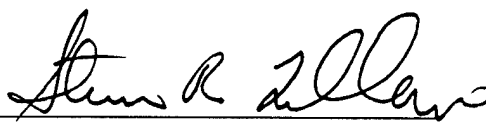

DR. STEVEN R. LECLAIR, Chief
Materials Process Design Branch
Integration and Operations Division
Materials Directorate

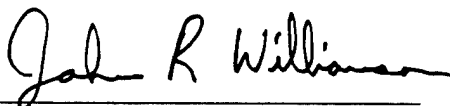

JOHN R. WILLIAMSON, Chief
Integration and Operations Division
Materials Directorate

If your address has changed, if you wish to be removed from our mailing list, or if the addressee is no longer employed by your organization please notify WL/MLIM Bldg 653, 2977 P Street, Suite 13, WPAFB, OH 45433-7746 to help us maintain a current mailing list.

Copies of this report should not be returned unless return is required by security considerations, contractual obligations or notice on a specific document.

REPORT DOCUMENTATION PAGE

Form Approved
OMB No. 0704-0188

Public reporting burden for this collection of information is estimated to average 1 hour per response, including the time for reviewing instructions, searching existing data sources, gathering and maintaining the data needed, and completing and reviewing the collection of information. Send comments regarding this burden estimate or any other aspect of this collection of information, including suggestions for reducing this burden, to Washington Headquarters Services, Directorate for Information Operations and Reports, 1215 Jefferson Davis Highway, Suite 1204, Arlington, VA 22202-4302, and to the Office of Management and Budget, Paperwork Reduction Project (0704-0188), Washington, DC 20503

1. AGENCY USE ONLY (Leave blank)		2. REPORT DATE DEC 1995	3. REPORT TYPE AND DATES COVERED FINAL 05/05/95--11/05/95	
4. TITLE AND SUBTITLE INTELLIGENT PROCESS CONTROL FOR PULSED-LASER DEPOSITION			5. FUNDING NUMBERS C F33615-95-C-5820 PE 65502 PR 3005 TA 05 WU 5J	
6. AUTHOR(S) JAMES A. GREER				
7. PERFORMING ORGANIZATION NAME(S) AND ADDRESS(ES) PVD PRODUCTS, INC. 35 CABOT ROAD WOBURN MA 01801-1003			8. PERFORMING ORGANIZATION REPORT NUMBER	
9. SPONSORING/MONITORING AGENCY NAME(S) AND ADDRESS(ES) MATERIALS DIRECTORATE WRIGHT LABORATORY AIR FORCE MATERIEL COMMAND WRIGHT PATTERSON AFB OH 45433-7734			10. SPONSORING/MONITORING AGENCY REPORT NUMBER WL-TR-96-4037	
11. SUPPLEMENTARY NOTES THIS IS A SMALL BUSINESS INNOVATION RESEARCH, PHASE 1 REPORT.				
12a. DISTRIBUTION AVAILABILITY STATEMENT APPROVED FOR PUBLIC RELEASE; DISTRIBUTION IS UNLIMITED.			12b. DISTRIBUTION CODE	
13. ABSTRACT (Maximum 200 words) This report reviews the activity in the field of thin films grown by Pulsed Laser Deposition (PLD) over the past ten years. Over 260 materials have been deposited by PLD for numerous applications, and the field is still very active. Applications for materials deposited by PLD are numerous and include areas such as electronics, opto-electronics, magnetic, tribological, and biological. At present, the most likely near term production application which will require laser deposited material is high temperature superconducting filters for use in the mobile communications industry. The market for such devices has been estimated at approximately \$500M. This report also describes unique tools with which to improve the infrastructure and help to control the pulsed laser deposition process. These tools include a novel deposition rate monitor based on atomic absorption which might also be used to monitor film composition as well. Also, an in-situ fluence monitor has been developed to measure the energy which actually enters the deposition chamber, and a constant fluence optical train has been designed to be compatible with large area PLD, based on raster scanning the laser over large diameter targets.				
14. SUBJECT TERMS PULSED LASER DEPOSITION, PLD, LASER ABLATION, INTELLIGENT PROCESS CONTROL			15. NUMBER OF PAGES 28	
			16. PRICE CODE	
17. SECURITY CLASSIFICATION OF REPORT UNCLASSIFIED	18. SECURITY CLASSIFICATION OF THIS PAGE UNCLASSIFIED	19. SECURITY CLASSIFICATION OF ABSTRACT UNCLASSIFIED	20. LIMITATION OF ABSTRACT SAR	

Intelligent Process Control for Pulsed Laser Deposition

Introduction

As this report will show, Pulsed-Laser Deposition (PLD) has become a very popular research technique with which to grow a wide range of different chemical compounds. To date, over 260 different materials have been deposited by PLD by numerous research laboratories around the world. The main focus of these laboratories has been on developing thin films of otherwise difficult to fabricate materials. While the process PLD has become very popular in recent years it has some potential drawbacks which need to be addressed if it is to become a standard deposition tool. Little attention has been paid to the scale-up the PLD process for large-area production applications. Furthermore, little infrastructure exists to support PLD either as a research tool or a full-fledged production deposition technique. An infrastructure needs to be developed in order to fully capitalize on the potential advantages of the laser deposition process.

PVD Products has conducted a survey of the work which has been on-going within the thin film community to find emerging applications for materials which are being grown by PLD that are nearing the production phase. One such material is the high temperature superconducting compound of $Y_1Ba_2Cu_3O_{7-x}$ (YBCO). Uses for YBCO are quite broad, and this material has several potential near-term applications including low-loss, narrow band filters for the commercial cellular phone market, as well as several low-loss microwave device applications for emerging military systems. In the latter half of this Phase I program, PVD Products developed a large-area PLD system concept which could address these emerging applications as well as provide PLD with some unique tools with which to monitor and control several of the relevant variables of the deposition process.

This report will discuss some of the more interesting findings of the PLD survey, as well as provide a concept for a large-area PLD system with which to deposit YBCO (or other materials). Three new techniques used to monitor and control some of the deposition parameters of this unique process will be discussed as well.

PLD Literature Search

A broad based search was conducted of the technical literature to find various applications for the PLD process. This included a computer search of the technical literature as well as a patents search. Telephone interviews were conducted with several researchers from various companies, universities, and government laboratories involved with the PLD process.

The computer search generated an extensive print-out of 56 pages of patents and 472 pages of technical articles for the last four years. Not all of the findings in the printouts were PLD related, but the bulk of the technical articles in the literature search were. As described below, a large

fraction of the work dealing with PLD process revolves around high temperature superconductors.

Over 125 US and foreign patents dealing with pulsed-laser deposition have been issued over the past five years. Over 25% of these patents are related to the growth of high temperature superconductors and related buffer layers. Over 26 Patents have been issued to the Japanese conglomerate Sumitomo Electric Industries. These Sumitomo patents mostly deal with the deposition of different high temperature superconducting compounds and buffer layers, process techniques, novel target preparations, equipment, as well as techniques to scale the process. Other Japanese companies actively involved in such patent activity include Matsushita Electric Industries, and Fujitsu Ltd. It is interesting that these companies are clearly working extensively with the laser deposition process to deposit HTS and other materials, but they do not publish their work in the open literature the way most Japanese universities and US companies typically do. The most active company involved in patents related to PLD in the US has been Energy Conversion Devices, Inc. They have been granted patents on fluorinated YBCO thin films with basal plane texture when deposited onto non-lattice matched substrates. ECD has also patented two ideas relating to the deposition of multilayers of Ge and Si for the use in solar cell applications. Jeff Cheung of Rockwell has also patented several ideas pertaining to PLD including reduced particle schemes, as well as techniques to deposit films on curved surfaces.

In 1992 Kathy L. Saenger's Appendix in the book entitled *Pulsed Laser Deposition of Thin Films* edited by D. B. Chrisey and G. K. Hubler (J. Wiley and Sons, 1994) listed over 175 materials which had been deposited by PLD up to that point. Since then, over 90 more materials have been deposited by PLD as described below. This list was comprised from both articles found in the literature, or from phone conversations with various researchers working in the field of PLD. Appendix A of this report provides a reference for each new material which has been deposited since 1993 not included in K. Saenger's list. The new list provides only one reference for each of these materials, as a comprehensive reference list for each material is well beyond the scope of this report.

The materials are broken down into several groups including high temperature superconductors (including buffer layers), ferroelectrics, magnetic materials, metals, hard and tribological coatings (including diamond and DLC), and other compounds. However, due to the large variety of materials and wide range of applications only selective compounds and applications are discussed in this report. Furthermore, applications based on superlattice structures are not considered, while they are of scientific interest, they are far to removed from useful near-term applications.

Low and High Temperature Superconductors:

High Temperature Superconductors remains the most active area of research utilizing the PLD process. Over 250 references were found in the literature search for films grown by PLD this class of materials, and of these YBCO is still the most popular HTS material being deposited by PLD. While an extensive amount of work has been conducted on the growth of thin films of HTS materials, production applications for YBCO appears to remain elusive. However, one commercial application appears to be on the horizon. The use of HTS materials to replace the

existing filter banks in cellular phone repeater stations is most likely the first large scale application for thin films of HTS materials. The incorporation of HTS materials into such filter banks will provide enhanced filter performance allowing more tightly spaced channels, while replacing a complete rack of power hungry YIG filters presently used in this application. Superconductor Technologies has been working on this application for several years, and according to Eric Smith at STI, when this process goes to production, STI will need to increase its throughput of HTS thin film material by between one and two orders of magnitude. Superconductor Technology will compete with Conductus, Inc. as well as Superconducting Core Technologies for this business. Conductus has been working in the growth of HTS materials using PLD as well as several other growth processes. Superconducting Core Technologies is a small start-up company which is currently assessing a variety of thin film deposition approaches. Projections for HTS wireless communications market indicate that sales will be on the order of \$500 million. STI is currently evaluating several technologies with which to grow HTS materials including PLD and MOCVD. While STI believes that MOCVD will likely be the technique used to grow materials such as YBCO for production applications this process is still under development. At present, STI has demonstrated YBCO films with T_c 's > 90 K, with J_c 's > 2 MA/cm² and $R_s \sim 1 \text{ m}\Omega/$ (scaled to 10 GHz) both measured at 77 K grown by MOCVD over two-inch diameter LaAlO₃ substrates. These MOCVD films still have CuO outgrowths with particle densities even more severe than that produced by the PLD process. Even with these encouraging results, STI feels that the best HTS materials are still grown by PLD. Furthermore, Eric Smith says that, in his view, PLD will provide all the materials for the most critical HTS applications which require the highest quality superconducting films for some time to come.

Other uses for thin films of HTS materials include Magnetic Resonance Imaging and Sensor Systems which are expected to generate markets on the order of \$150 million and \$100 million, respectively. Furthermore, a wide variety of microwave devices such as low-loss filters and delay lines are being developed for military applications. High Q resonators for very low noise oscillators, power transmission lines, low loss antennas, and more. The market size for these military microwave applications is presently unknown. However, it is unlikely that these types of devices will be incorporated into military hardware until several devices are integrated a complete superconducting package which makes efficient and cost effective use of the associated cryogenic system

In the last few years, new compounds of superconductors have been deposited by PLD as well. The Hg based HTS material (HgBa₂CaCu₂O_y) has been grown in thin film form by laser ablation at 248 nm. Several other HTS compounds including TmBaSrCu₃O_{7-x} and TmBa₂Cu₃O_{7-x} along with PrBa₂Cu₃O_{7-x} and PrBa₂Cu₃O_{7-x}. Buffer layers for YBCO of LaAlO₃ and NdAlO₃ were formed on sapphire substrates by depositing LaO₂ and NdO₂ and annealing the films at elevated temperatures. Furthermore, metallic low temperature superconductors of MoN_x, NbN_x and SnSi have been grown at NRL using 248 nm.

Ferroelectrics:

A wide variety of ferroelectric materials have been deposited by PLD. Several of these materials display spontaneous polarization which makes them useful for several applications. Such applications include non-volatile Random Access Memory (RAM), capacitors based on materials with high dielectric constants and microelectromechanical structures. These materials include a

variety of oxide compounds such as SrTiO_3 , BaTiO_3 , PLZT, BaSrTiO_3 , $\text{Bi}_4\text{Ti}_3\text{O}_{12}$, KTN, PbGeO_{11} , PbTiO_3 , to name a few. Thin films of these materials grown by PLD have demonstrated some very encouraging performance, but have not yet made it into commercial applications for a variety of reasons. The high dielectric applications suffer mostly from the low breakdown voltages of a large fraction of the capacitors. While some capacitors demonstrate the ability to withstand high voltages, the applications would require that a large fraction ($f > 99\%$) of the capacitors formed by the film can withstand the design voltage (typically between 3 and 10 V). The RAM applications suffer from several problems including larger than desired leakage currents and retention. While improvements in the retention of the films have been realized by a variety of techniques (some PLD based), these materials are not expected to enter the commercial market place in the short term.

Even if PLD demonstrated the ability to grow these compounds with the desired properties other hurdles need to be overcome before these materials are used for the intended applications. For example, some companies interested in developing these applications are concerned about the fact that PLD is not a standard deposition technique. One such company, a mid-sized California based capacitor house, said that they would not invest in PLD until other companies involved in similar technology, such as Motorola, Intel, or Hewlett Packard had already done so. This barrier of corporate fear of any new process will be difficult to break. Furthermore, integrating these materials into Si and GaAs technology will take some materials development to overcome the large differences in thermal coefficient of expansions and high anneal temperatures for several of the relevant compounds.

Magnetic Materials:

Several classes of magnetic materials have been deposited by PLD these include oxides and non-oxides alike. The applications include ferromagnetic components based on thin films, and magnetic memory storage. ARPA has funded a Ferromagnetic Consortium for about three years. Under this funding a variety of ferromagnetic materials have been deposited by PLD including YIG, NiFeO_4 , $\text{Zn}_x\text{Fe}_{3-x}\text{O}_4$, and $\text{BaFe}_{12}\text{O}_{12}$. The devices fabricated with these materials include microwave circulators, isolators, tunable phase shifters and filters, and delay lines. The major problems associated with these applications are two fold. First, thick films are needed for most applications varying from over 25 μm for devices which operate at 35 GHz, to over 100 μm for devices which operate at X-band. Deposition rates approaching 15 $\mu\text{m}/\text{hour}$ have been demonstrated, and films over 100 μm have been deposited. However these deposition rates and film thickness have been obtained over small areas only. Either multiple or more powerful excimer lasers will be required to obtain growth rates approaching 50 to 100 $\mu\text{m}/\text{hour}$ over areas approaching 100 to 200 cm^2 . The other problem associated with this application is that the goal is to deposit these materials on substrates such as Si and GaAs. This presents a variety of materials issues including film stress, thermal coefficients of expansions mismatches, and low deposition or post-deposition anneal temperatures. While some progress has been made in these areas the properties of the films deposited onto these substrates still need to be improved for the intended applications.

Other magnetic materials which have been deposited over the last few years include $\text{La}_{1-x}\text{Sr}_x\text{MnO}_2$, $\text{Nd}_{0.7}\text{Sr}_{0.3}\text{MnO}_3$, and $\text{Co}_x\text{Cu}_{1-x}$. These materials display Giant Magneto Resistance (GMR), which has potential use in magnetic recording applications. The basic physics of these

materials are still being studied, and the thin films formed by PLD display some interesting and yet unexplained results. Also, the GMR effect is dominant near the magnetic phase transition for the material and strongly depends on film composition.

Metals

Almost all the metals have been deposited by PLD. While the low temperature metals such as Al, Au, Fe, and Cu produce lots of particulates yielding rough surface morphologies, the more refractory metals such as Pt, Co, Ti, V, Nb, W, Re, Ni, and Ta produce some of the smoothest films grown by PLD. Most applications to date have been for simple electrical contacts to devices made from films also grown by PLD. For the most part, the deposition of these metals would most likely be conducted using more standard techniques such as electron beam evaporation or sputtering. However, some applications for metals deposited by PLD exist. These include the deposition of materials such as W and Re for use in X-ray photolithography masks. The advantage of PLD in this case is its ability to deposit only a small amount of material with each laser pulse, thereby obtaining multi-layer films with precise and abrupt interfaces. Work in Germany is focusing on the use of these materials for making 4-inch diameter X-ray photomasks. Other applications for metals include thin film batteries. Here, the application is for contact to the electrolytes. The contacts are typically formed with proprietary alloys which contain between 6 and 9 different elements. PLD allows the users to easily obtain films of these materials with the correct composition more easily than any other deposition approach. Magnetic metal alloys have also been deposited for magnetic recording head applications. Multilayer metals have also been used to form x-ray mirrors.

Other applications includes reactive metal deposition to form new compounds. Such examples include laser ablation of Mg in oxygen to form MgO (a buffer layer for HTS compounds). Since MgO does not readily absorb the UV radiation, reactive ablation of the metal forms a convenient means of obtaining the desired material. Another example is that of ablation of V in oxygen to form various VO compounds for IR detector applications. On final example of this approach is plasma enhanced PLD of liquid Ga in a NH_2 atmosphere. In this case, the plasma dissociates the ammonia providing atomic N to form GaN. This material has several electrooptic applications.

Tribological and Hard Coatings:

A variety of materials have been deposited for both tribological and protective coating applications. These materials come in two basic forms, solid lubricants and hard coatings. Included in the solid lubricant class are compounds such as MoS_2 , WS_2 , NbSe_2 , NbS_2 , and NbTe_2 . Other materials include hBN, CF_x , TiO_2 , PbO , PbMoO_4 , CeF_3 , BaF_2 , and CaF_2 . Hard coatings include materials such as cBN, DLC, B_4C , Cr_3C_2 , SiC, TiC, Si_3N_4 , TiN, C_3N_4 , and various oxides. It turns out that the intrinsic stress in the oxide films can be controlled by controlling the background gas pressure during deposition and that the hardness of the materials has been found to depend on the film stress.

Some recent work in the area of hard coatings includes the laser deposition of diamond films. In this case a hot filament was placed directly in front of the substrate in an H_2 background. The filament dissociates the hydrogen forming a sufficient atomic flux to the substrate surface to preferentially etch away any sp^2 bonded C which is formed from the condensing vapor produced by

the ablation of a graphite target. Diamond films have been reported to have been grown at substrate temperatures as low as 600°C using this PLD approach.

DLC has been grown by PLD for several years and has many different applications. One application is related to the flat panel display market. DLC has been used as the field emitters in cold cathode flat panel displays by SI Diamond, Inc. They have successfully fabricated DLC films over areas of about 4 square inches and have made working displays. However, it appears that SI Diamond is now looking towards CVD deposition of diamond for future larger area display devices.

Another related hard material is that of C_3N_4 . This material has been deposited by PLD in conjunction with an RF atomic nitrogen source by researchers at Harvard, and this compound is predicted to be harder than that of diamond. It is still unclear which phase or phases of C_3N_4 is being formed in the PLD process, and research continues.

Work on the growth of cBN is still continuing, but it is unlikely that PLD will be the best way to deposit this material over large areas. This is due to the fact the material is grown by an ion beam assisted PLD process, and the ratio of the neutral B and N fluxes need to be balanced properly in order to get the proper cubic phase. The problem is to obtain the proper fluxes to the entire substrate with the PLD approach where the plume is highly forward directed. Many applications for cBN include hard coatings for tools and several microelectronic applications.

Other Materials:

A variety of other oxide materials have been deposited for a variety of applications. Flat Panel Displays based on Field Emitter Arrays (FEA's) are in need of efficient phosphors materials in thin film form. Such materials have been deposited by PLD including Eu, Tm, and Tb doped YAGG to form red, blue, and green phosphors, respectively for high brightness applications. Furthermore, SrS doped with either Eu or Sm has been deposited for low voltage displays applications. Another emerging thin film phosphor is the thiogallate Ce:CaGa₂S₄, which has been grown by both MOCVD and more recently, PLD. Finally, conductive transparent oxides are needed in thin film form to act as either an over or underlayer for the phosphor materials. Both In₂O₃ and GaInO₃ have been deposited by PLD. GaInO₃ has the advantage of a broader transmission band than In₂O₃.

Another interesting oxide is Yb₂O₃. This material has been deposited on Si substrates to be used as a selective emitter for energy conversion applications. When this material is heated it emits intense light at about 1.1 μm, which is very close to the peak absorption in Si based solar cells. Thus, electricity can be formed readily by heating the Yb₂O₃ film with a flame generated by butane providing an efficient mobile power source. Another similar oxide, BaZrO₃ has been successfully deposited by PLD for direct thermoelectric conversion applications. A non-oxide related material, CuInSe₂ or CIS, for use in solar cells has also been deposited by PLD.

The Japanese have also been working on depositing a variety of piezo-electric materials including LiTaO₃ and LiNbO₃ for SAW devices. Such devices could be used for a variety of filters in everything from garage door openers to cellular telephone applications. There is interest in

scaling up PLD process to 4-inch diameter substrates to address applications for such devices from a Japanese based company.

Biological materials have also been deposited. Kathy Cotell from NRL has deposited hydroxiapatite material for orthopedic implant applications. More recently, she has reported on the successful deposition of films of bovine (cow) collagen material. Applications for such collagen films would be to aid in the healing of burn victims.

Large-Area PLD System Design Concept

It appears that the high temperature superconducting compounds, and in particular, YBCO, will be the first materials to be utilized in commercial and military systems. However, until the proper infrastructure for the PLD process is developed, the applications will not be realized unless other deposition approaches improve significantly in order to match or exceed the quality of films presently being deposited by PLD. In order to create an infrastructure to support the process and help PLD become a standard deposition technique, several key areas need to be addressed. These include the size of substrates which can be coated uniformly by PLD, deposition rate monitoring and control, and the accurate measurement and control of the "on-target" laser fluence. Furthermore, for certain applications, such as the in-situ growth of HTS materials, reliable, large-area substrate heaters are needed. A number of these area's were addressed as "paper-studies" under the scope of the Phase I program, and the results are presented below. The idea was to develop the framework for a large-area PLD system which could be used to demonstrate that PLD process can in fact be used for large-area deposition and meet the demands of both commercial and military applications for YBCO. In this case, a system capable of addressing 100 mm (4-inch) diameter substrates was considered. This size substrate was chosen as it is the largest size available for LaAlO_3 , the material of choice for most thin film HTS applications.

Large-Area PLD Approach

The best approach to scaling up the laser deposition process is to use large-area targets along with programmable laser beam rastering and substrate rotation. This approach has been successfully utilized to uniformly deposit films over 200 mm (8-inch) diameter substrates. The process also provides for incorporating the deposition rate monitor described below, as well as the on-target laser fluence measurement scheme. A schematic of a large-area deposition system is shown in Figure 1. Here an incident excimer laser beam is reflected off a programmable mirror through a window (discussed in detail below) which rasters the laser beam across a radii (or full diameter) of a large diameter target. Allowing the beam to dwell longer at larger target radii provides for uniform properties of the film deposited onto the rotating substrate located about 15 cm away from the target. The target is also rotated so that the target material is removed at a constant rate over the target surface. This technique has several advantages over alternative large area approaches which utilize small area targets with fixed position laser beams. First, with proper care, target resurfacing is not required, and it is much easier to obtain reproducible results. Furthermore, the life times of the large area targets are significantly longer than that of the standard small diameter targets and target trenching is non-existent.

Also shown in Figure 1 is a large-area substrate heater which utilizes black body radiation to heat the transparent LaAlO_3 substrate. With this approach, the substrate is suspended only at its

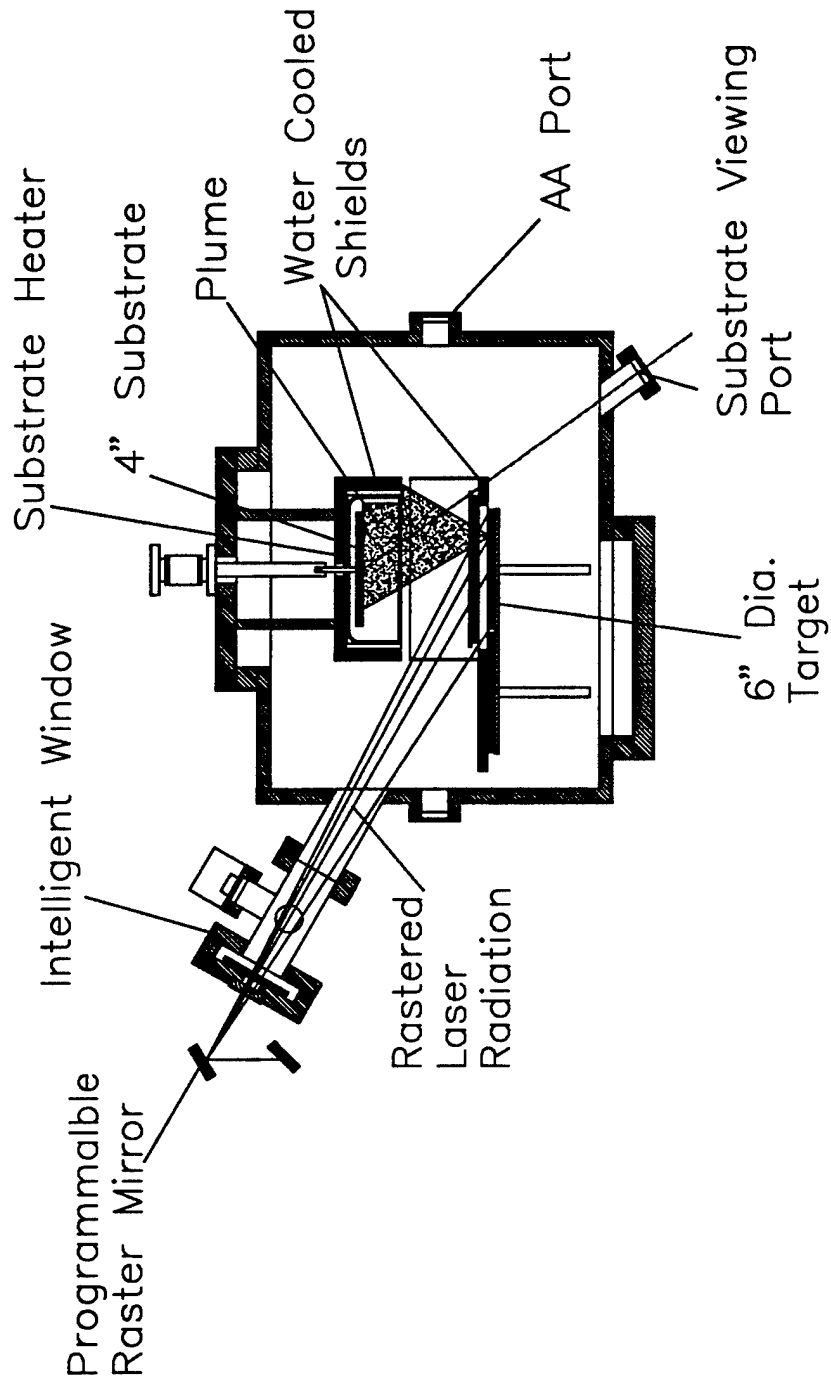

Figure 1. Schematic of a Basic Large-Area PLD System for Depositing YBCO over 4-inch Diameter Substrates

edges, and does not make any other contact with the substrate holder. Thus, silver paste is not required to heat the substrate. The advantage of this approach is that it provides more uniform heating of large-area substrates, and the fact that the backside of the substrate remains clean making subsequent process step easier. On the other hand, this approach requires more energy to be put into the system to heat the substrate which puts a strain on the heating elements. Furthermore, since the substrate is not in good thermal contact with a heated block the substrates temperature can only be inferred from the heat input. However, this black body approach has been accepted by several labs depositing HTS materials over large area substrates including Superconductor Technology, Conductus, Naval Research Labs, to name a few. Water cooled shields will be required to remove the estimated 3 kW of energy required to heat the 4-inch diameter substrate to temperatures of up to 750°C. A water cooled shield will also sit directly in front of the ablation target in order to minimize the targets temperature during deposition as shown in Figure 1.

Deposition Rate Monitoring:

Figure 2 shows the incorporation of a proposed deposition rate monitor into the large area PLD system. The rate monitor is based on an existing product called ATOMICAS which is sold by Intelligent Sensor Technology, Inc. of Mountain View Ca., and utilizes Atomic Absorption (AA) to calculate the density of the condensing vapor species. The current ATOMICAS system would need to be modified to make it compatible with the pulsed nature of the PLD process.

Atomic Absorption Spectroscopy (AAS) has shown to be a powerful technique for monitoring deposition rates in conventional physical vapor deposition process such as thermal evaporation and sputtering. Its utility as a diagnostic tool for laser ablation of YBCO has also been demonstrated by several groups. Preliminary estimations from published data of the values of key parameters of Cu atoms in a PLD system indicate the following.

Atomic number density near the substrate	$n \sim 10^{11} - 10^{12}/\text{cm}^3$
Absorption at $nl \sim 50 \times 10^{10}/\text{cm}^2$, where l is the absorption path length in cm	$A = 50\%$
Plume flyby time near the substrate	$t \sim 50 \times 10^{-6} \text{ sec}$

Due to the pulsed nature of the flux to be detected, the proposed scheme of an AA monitor for the PLD process will be different from that incorporated in the ATOMICAS (JVST A13, 1797 (1995)). A schematic diagram of the modified system is shown in Figure 2. This configuration has the advantage that the entire sensing device is external to the deposition chamber. However, due to the long absorption path length, the absorption signal may be saturated for dense ablation plumes. In such a case, a fiber optic probe with a shorter absorption path length on the order of a few mm may be a better choice. To prevent the windows from becoming coated in standard deposition systems the windows are mounted on flanges with long tubes with a high aspect ratio. A similar approach will be taken for the PLD process, but with the forward directionality of the ablation plume, AA window coatings are not expected to be a problem. In the proposed system, a copper Hollow Cathode (HC) lamp produces a very narrow band DC light beam which passes through the deposition region as shown. Copper is the best choice to monitor the deposition rate of the YBCO compound since ground state Cu has a large absorption cross section, it is the most abundant of the metal cations in the YBCO compound, and Cu hollow cathode lamps have a higher output energy than that of Y or Ba lamps.

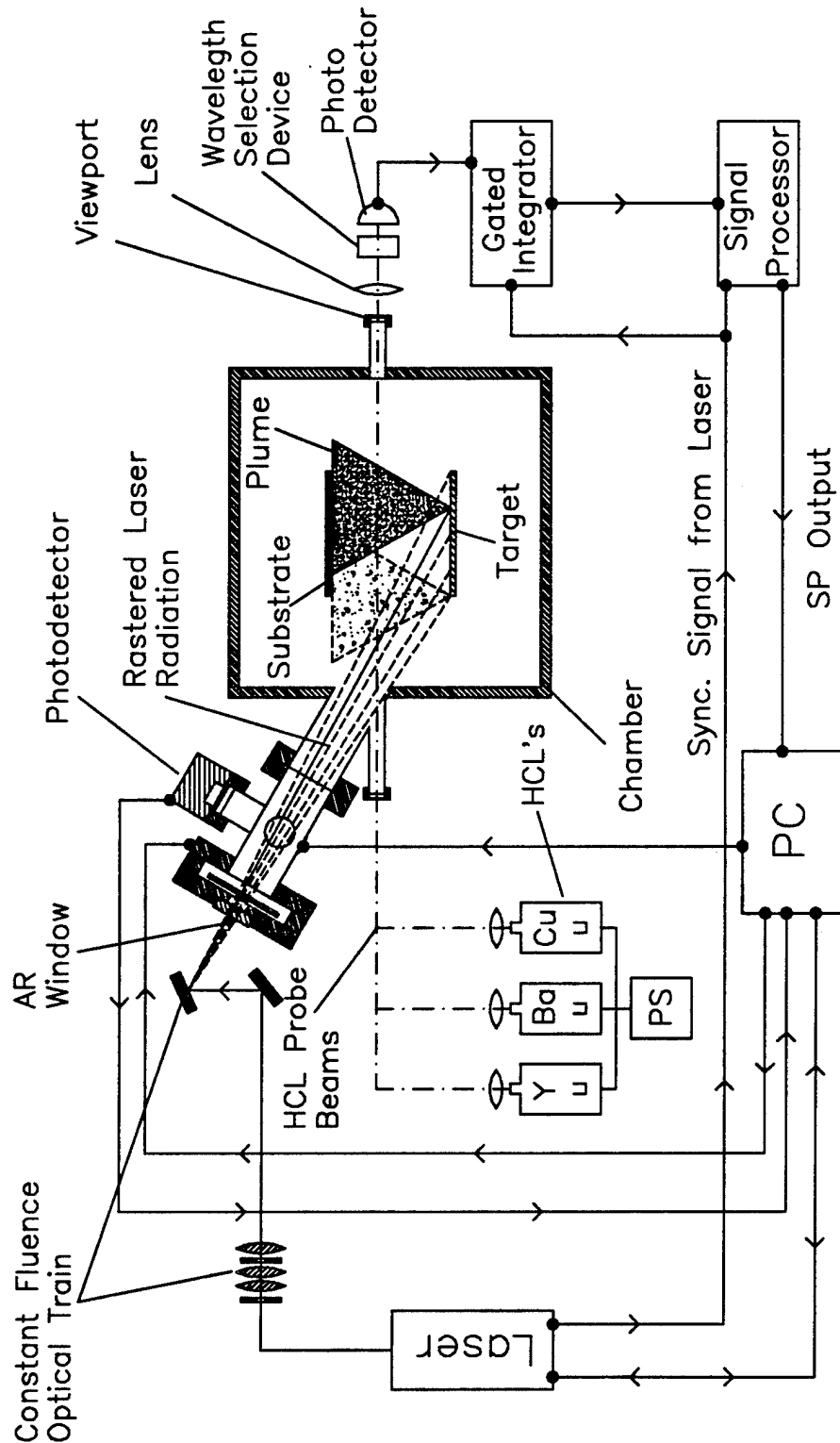

Figure 2. Schematic of an Atomic Absorption Deposition Rate Monitor Incorporated Into a Large-Area PLD System. This System is Shown With 3 HCL's and Could Be Used For Monitoring of the Film Composition as Well.

To achieve a high signal-to-noise ratio from the detector output, the atomic line emission source needs to be as intense as possible. Typically, outputs of a hollow cathode lamp at the strongest atomic emission line is less than 10^{-8} W. Due to self-absorption, this optical output power can not be increased by operating the HCL at a higher current. Tunable diode lasers are capable of providing much higher optical power, but these devices are limited to wavelengths in the visible region. In fact, a diode laser operating at 670 nm has recently been used in for monitoring Y deposition in an evaporative YBCO growth process by Stanford University with excellent accuracy and signal to noise ratio allowing them to resolve deposition rates as low as $0.03 \text{ \AA}/\text{sec}$. In the proposed system we plan to use a Cu HCL as the light source in combination with a photodetector with the highest sensitivity and the lowest noise. Conventional HCL's are relatively low cost (\$100-\$450), and have long life (at least 500 hours under normal operating conditions). Thus, with a deposition rate of $\sim 1 \text{ \mu m}/\text{hour}$ for YBCO over 4-inch diameter and a desired film thickness of $\sim 1 \text{ \mu m}$ (which is thicker than usually used for HTS applications), the lamp will last at least 500 runs. Thus, the cost to run the lamp for a typical film growth will be approximately \$1 which compares to the cost of $\sim \$850$ for a 4-inch diameter LaAlO_3 substrate. In the proposed system, the HCL will operate in a DC mode during deposition. The interaction of the ablation plume with the probing optical beam will cause a short decrease in the optical intensity reaching the detector. A wavelength selection device (either a narrow band optical filter or a monochromator) tuned to the atomic emission wavelength is placed in front of the photodetector to reject unwanted radiation from the ambient and the HCL. Due to the short duration of absorption, a fast photodetector is necessary. On the other hand, the limited light output of the HCL also demands for the detector to have the highest signal-to-noise ratio possible. A logical choice for the detector is the photomultiplier tube (PMT) for its high sensitivity and fast response. A gated integrator will also be used to capture the short drop in the optical signal and detect the change of transmission in the optical train for normalization purposes. The basic signal detection scheme is shown in Figures 3 and 4. With the gated detection system in sync with the laser, each measurement cycle involves the determination of light intensity from the HCL with and without absorption by the ablated plume. The difference between the two measurements thus determines the absolute absorption value regardless of any long term drift in the HCL output or changes in window transmission due to deposited film coatings.

At the Cu emission line of 325 nm, a typical PMT has a quantum efficiency of about 20% and a cathode radiant sensitivity of about $0.05 \text{ A}/\text{W}$. For a gating period of $100 \times 10^{-6} \text{ s}$ and a cathode current of $5 \times 10^{-10} \text{ A}$ (assuming an optical radiant power of $1 \times 10^{-8} \text{ W}$ at the cathode), the theoretical shot noise limitation on the S/N ratio is only about 5×10^2 . Furthermore, in the absorption process, the real signal is the amount of optical signal reduction due to absorption, not the full scale signal used for calculating the above S/N ratio. This signal reduction is a function of the gating period and may be only a small fraction of unabsorbed signal. A short gating period is favored for a large signal change due to absorption, but at the expense of poorer S/N ratio. Other factors, such as the uncertainty in the time delay between the laser and arriving plume, must also be considered in choosing the optimal gate width. In practice, it is necessary to use a gate width which is longer than the plume fly-by time, and consequently resulting a less favorable "real signal" due to absorption. It appears that for Cu, a S/N of 1×10^2 may be achievable using the above parameters in a real system. By averaging 100 samples the S/N ratio will be improved by a factor of 10 (square root of 100) to a respective value of 1×10^3 . Using a repetition rate of 100 Hz the response time of the system will be 1 second, which is more than adequate for "real-time"

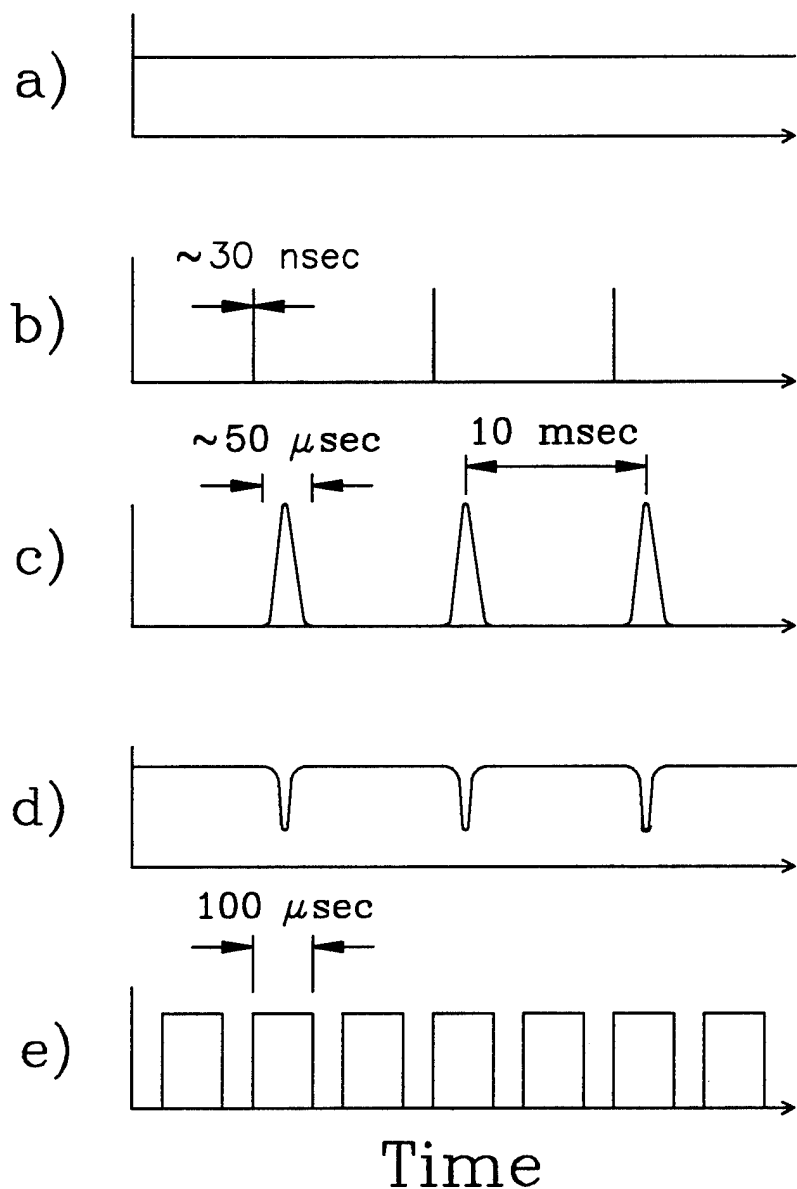

Figure 3. a) The Output Intensity as a Function of Time From the Cu Hollow Cathode Lamp. b) The Temporal Profile of the Laser Pulses Incident on the Ablation Target. c) The Temporal Profile of the Ground State Atomic Cu Flux Density as it Passes Through the AA Probe Beam. d) The Temporal Profile of the HCL Lamp Intensity as Measured by the Photomultiplier Tube. e) The Gating Signal Used for Data Acquisition.

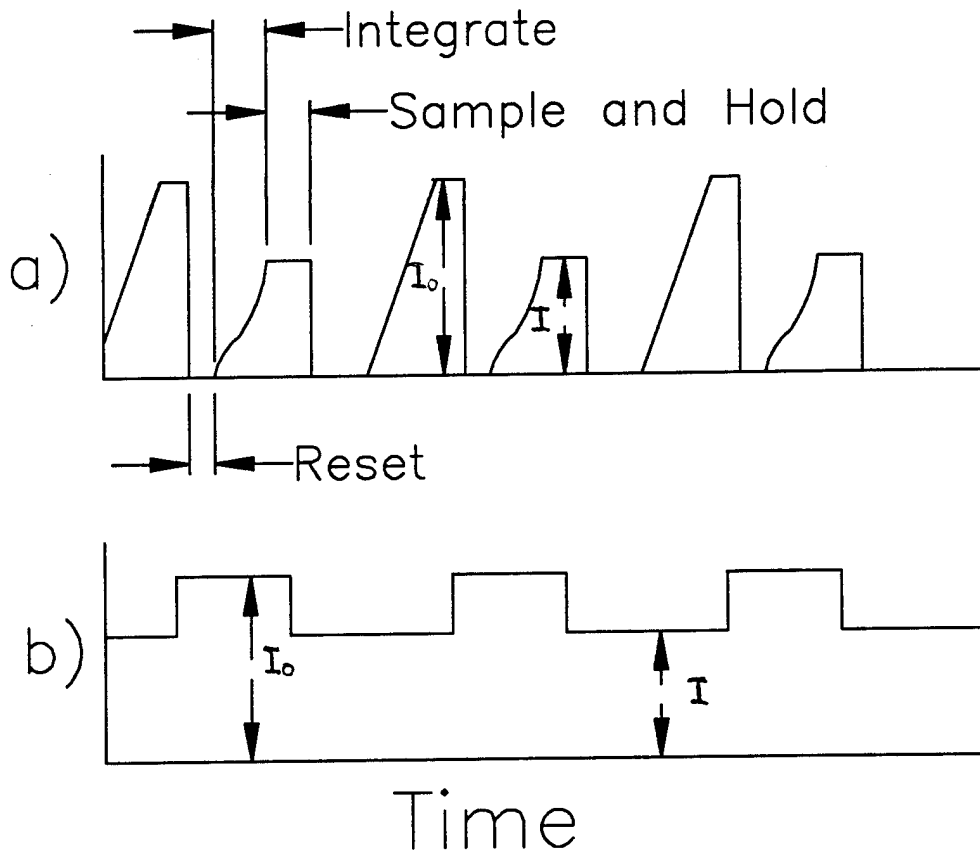

Figure 4. a) Schematic of the Gated Integrator Output as a Function of Time.
b) The Corresponding Sample-And-Hold Signal Provided to the Microprocessor or Computer.

feedback control purposes of the PLD process. This means that one can control the Cu atomic density to better than 1% with a 1 second response time. To further improve the performance, new light sources need to be evaluated with higher intensity or to average more pulses which would result in a lower response time. For materials, such as Y, whose wavelengths are accessible by tunable diode lasers, their usage may be worth consideration.

Simultaneously using three HCL lamps, one for Y, Ba, and Cu, with the associated detectors, would possibly allow the composition of the plume to be monitored in real time, as well. A system which incorporates three such HCL's is shown in Figure 2. In such a system, the Cu line could be used to control deposition rate through proper feedback control, and the condensing film composition could be monitored, and possibly controlled by varying deposition parameters such as laser fluence, substrate temperature or background gas pressure. However, in order for the composition of YBCO to be accurately monitored and controlled, a software package would need to be developed to obtain data in real time, utilize an extensive data base which keeps track of multiple YBCO film compositions (as determined by RBS or EDXA) for films deposited under several conditions, and make the appropriate parameter response in order to obtain the correct film composition.

On-Target Laser Fluence and Control

Another aspect of creating the proper infrastructure for the PLD process is to provide a way to accurately measure and control the energy which reaches the ablation target. According to Eric Smith at Superconductor Technologies, the on-target fluence needs to be controlled to within $\pm 5\%$ in order to produce the highest quality YBCO films. However, most PLD systems today cannot accurately measure or monitor the energy entering the deposition chamber. Typically, researchers monitor the output energy of the laser and assume that a fixed fraction of that output energy is reaching the target. However, the energy reaching the target may change for a variety of reasons. Simply cleaning the laser optics can increase beam brightness, even at a fixed output energy, thus increasing the fluence. Changes in beam brightness can produce variations as much as 20 to 25% in the on-target laser fluence. Furthermore, as the deposition process proceeds, the entrance window for the laser beam becomes coated with some of the ablated flux. This is more of a problem for large-area systems where a lot more material is usually deposited. The window coating may be removed somewhat by the laser beam, but since the fluence is usually low at the window the film tends to build up. If the window coating is removed by the laser beam it also tends to remove some of the underlying fused silica material with it, altering the surface texture of the window. This degradation in the window optic also causes degradation in the uniformity of the focused laser spot.

A solution has been developed by PVD Products, Inc. to overcome these problems. A schematic of the "Intelligent WindowTM" is shown in Figure 5. In this case, a high quality AR coated Suprasil II window acts as the chamber entrance window for the laser beam. Directly inside the chamber is a second "sacrificial" quartz window which can be rotated by a rotary feedthrough (not shown). A small aperture is located in front of the internal quartz window to minimize the area of the coating which reaches this sacrificial plate. Thus, as the internal window gets coated and the fluence drops, a fresh surface can be exposed to the laser beam without breaking vacuum by simply rotating the feedthrough. Furthermore, a reflecting optic can be placed directly in front of the incident laser beam and reflect the incident light energy which enters the chamber out

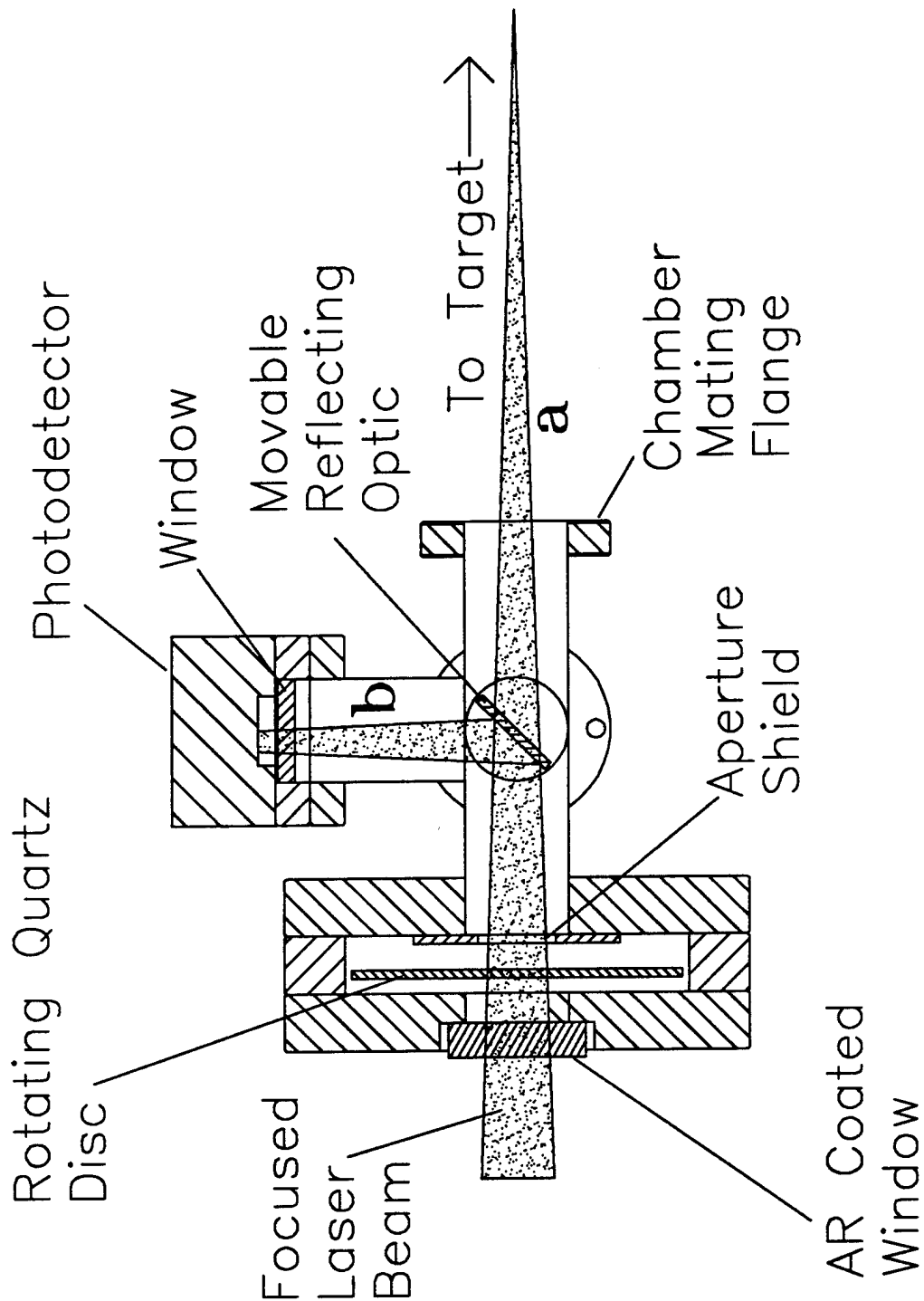

Figure 5. Schematic of the Cross-Section of an "Intelligent Window™".

through a second window as shown in Figure 5. The reflected energy can then be measured by an appropriate detector. Thus, the energy which actually enters the chamber can be measured before, during, or after each run. If the energy changes during a run, then, with proper system control, the appropriate steps can be taken to alleviate the situation.

Several "Intelligent Windows™" have been built, tested, and sold to customers. These units are all manually controlled without interfacing to computers for real time monitoring and control. However, it is a relatively straightforward task to motorize the actuators and interface them to a computer with the proper intelligent control software.

Constant Fluence Optical Train:

One of the problems with large-area PLD systems which have utilized a rastered laser beam and a simple focus type optical train is the fact that the on-target laser fluence changes as the laser beam is rastered across the large diameter target. This is due to the fact that the laser spot size changes in response to the slight change in laser beam path length. This problem becomes more serious as the raster path length increases to accommodate larger target (and substrate) sizes increase.

A concept for a constant fluence optical train has been developed for use in the large-area PLD system for operation at 248 nm. A schematic of the system is shown in Figure 6. The output of the laser passes through an adjustable beam attenuator to set the desired output energy. This system also includes an anamorphic relay to image and re-size the laser exit pupil onto a rectangular aperture, a beam homogenizer which consists of two elements to produce a uniform image of the aperture on the ablation target, and two programmable scanning mirrors which allows the beam to be rastered across a large diameter target. The anamorphic relay consists of two pairs of cylindrical lenses, one pair imaging the horizontal axis of the laser beam, and the other pair imaging the vertical axis. These lens pairs, which are interleaved, will be designed to produce a suitably sized image of the rectangular laser exit pupil at an aperture, while maintaining collimation. The homogenizer starts with an aperture, followed immediately by a four-segment lens which breaks the beam into four identically-sized sub-beams. A second four segment lens recombines the sub-beams in the target plane and simultaneously images the aperture onto the same plane. Thus, a uniform, well defined beam will be produced and impinge upon the target. The fluence will be kept to a low level at both the relay and homogenizer elements while maintaining a practical optical path length by using a demagnification factor of 3X for the beam homogenizer. This results in an optical path length of approximately 3 meters from laser to the vacuum chamber's entrance window for the system present design. Thus, the beam will need to be transported by a set of relay optics in order to obtain the desired on-target properties depending on laser and chamber locations. The optical system described should be able to produce fluences of up to 5 J/cm^2 with an overall optical efficiency of ~65% while keeping the on-target laser fluence constant to within $\pm 5\%$. Once the scanning mirror is properly programmed, the PLD system should be able to produce very uniform and reproducible films over large diameter substrates.

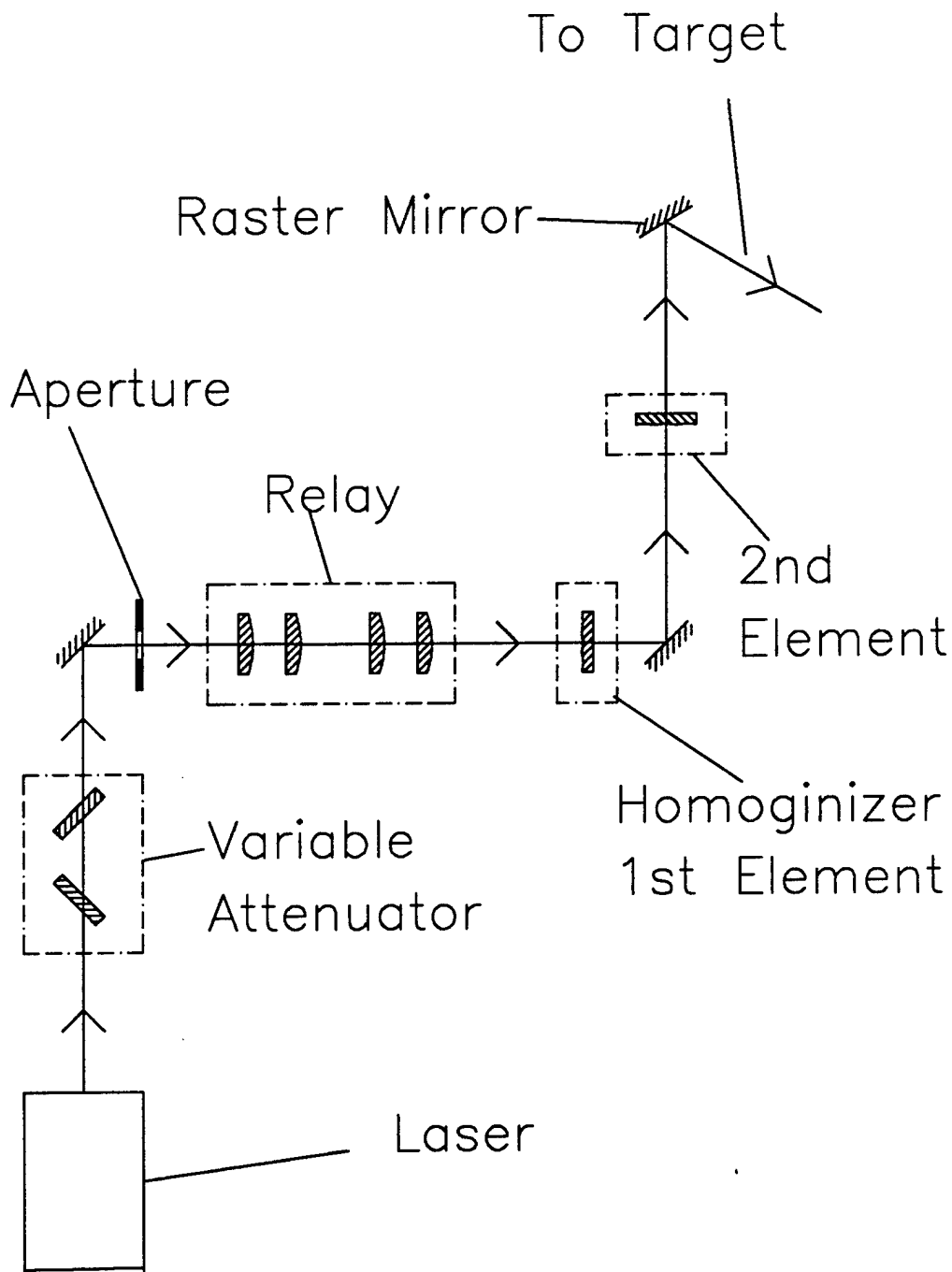

Figure 6. A Constant Fluence Optical Train for the Large-Area PLD Process. The Overall Optical Path Length is about 3 Meters.

Summary of Phase I Accomplishments

The objectives of Phase I were to first conduct a comprehensive literature search of the emerging PLD process and determine potential near-term applications. The second objective was to develop and evaluate feedback control processes which could be used to improve the performance of a large-area PLD to help make it compatible with production-oriented applications.

A comprehensive search for the PLD process was conducted of the technical literature over the last four years and builds upon work published in "Pulsed Laser Deposition of Thin Films" (Edited by D. B. Chrisey and Graham K. Hubler, J. Wiley and Son 1994). Over the past ten years this process has become a very useful research tool with which to deposit thin films of well over 250 different materials for literally hundreds of different applications. The number of groups involved in PLD is still increasing at a rapid pace, and with the level of ongoing research utilizing this unique deposition tool, it is likely that several applications requiring production equipment will soon emerge. At present it appears that YBCO is the material which is closest to production applications. The cellular phone market place for YBCO is projected to be ~\$500M, and at present, there is no clear deposition approach for YBCO which is capable of meeting the throughput demands for this application.

It is clear from the literature search that before PLD becomes a useful production tool the proper infrastructure needs to be built up to support large-scale production-oriented applications. This infrastructure includes the ability to deposit films over large areas with the uniformity required for the particular application, better process control including deposition rate monitors, composition monitors, improved lasers, as well as computer-controlled closed-loop feed-back of numerous deposition variables. Temperature monitors for transparent substrates used for several PLD applications (including HTS materials) and large-area robust oxygen resistant heaters are needed as well. Furthermore, the inherent fear displayed by "Corporate America" of something "new" needs to be addressed and overcome. It is likely that PLD will be used first not by large corporations, but by small start-up companies such as Superconductor Technologies or Conductus, which have niche applications that cannot be addressed with alternative deposition techniques. As an infrastructure is built up to support the PLD systems installed at these small companies, then larger corporations will be more willing to buy into the process for their own particular applications.

During the second half of the Phase I Program the design of a number of process control devices were evaluated which should significantly improve the infrastructure of production oriented PLD. These include a deposition rate monitor which is based on atomic absorption for the PLD process. It appears that making modifications to an existing commercially available deposition rate product could yield a film growth rate monitor which is compatible with large area PLD. Furthermore, an extension of the AA technique which utilizes three sources with three independent detectors was designed. With proper calibration and computer control this three element AA unit may allow the composition of the film to be monitored during deposition as well. A constant fluence optical train was also designed to be compatible with large area PLD. This system coupled with the Intelligent Window should provide an excellent way to measure and control the on-target laser fluence during laser deposition. Finally, a basic large-area PLD system to deposit YBCO over 4-inch diameter substrates was designed. This design of this system is compatible with the incorporation of the AA rate monitor, constant fluence optical train, and Intelligent Window.

Proposed Future Work

In Phase I we have developed a basic design for a large-area PLD system which is capable of depositing YBCO films over 4-inch diameter substrates. Future work will focus on the realization of a large-area PLD machine which incorporates an AA deposition rate monitor, constant fluence optical train, Intelligent Window, with a computer control package which will be able to monitor and control the complete PLD process.

The results of this research effort will be a commercial large-area PLD source for advanced materials compatible with production applications. This source will be capable of large-area, high rate deposition of high T_c superconductors as well as ferroelectric, piezoelectric, magneto-optic and non-linear optical materials. All of these materials have been identified as critical to the success of the US advanced materials and processing community. Furthermore, each of the process control items discussed above will be developed into individual products which can bolt onto existing small area research-based PLD systems. These products will help to further advance the productivity of these research based machines.

Appendix A

Additional Materials Deposited By PLD Since 1993

Material	Comment	Laser	Reference
C ₆₀	Buckyballs	KrF (248 nm)	Yoshimoto et al. , 1993
Tb:YAGG	Thin Film Phosphor	KrF (248 nm)	Greer et al. 1994a
Eu:YAGG	Thin Film Phosphor		Greer et al. 1994a
Tm:YAGG	Thin Film Phosphor		Greer et al. 1994a
Tb:YAG	Thin Film Phosphor		Hirata et al. 1995
SrS:Eu,Sm	Thin Film Phosphor		Mathews, et al 1994
Ce:CaGa ₂ S ₄	Thin Film Phosphor	KrF	Unpublished
GaInO ₃	Transparent Conducting oxide	KrF (248)	Phillips, et al. 1994
Yb ₂ O ₃	Thermophotovoltaics	KrF (248)	Greer 1994 unpublished
CuInSe ₂	photovoltaics	XeCl (308)	Levoska et al. 1993
LiCoO ₂	energy storage	XeCl (308)	Antaya, et al. 1994
Pr ₂ O ₃			Tarsa et al. 1993
LaO ₂	HTS Buffer layers	KrF (248)	Greer et al. 1990
NdO ₂	HTS Buffer layers	KrF (248)	Greer et al. 1990
TmBa ₂ Cu ₃ O _{7-x}	HTS		Rao et al. 1995
TmBaSrCu ₃ O _{7-x}	HTS		Stangl et al. 1995
(CaCuO ₂) _m (Ba ₂ CuO ₂ CO ₃) _n	HTS		Allen et al. 1995
PrBa ₂ Cu ₃ O _{7-x}	HTS	XeCl (308)	Sung et al. 1994
HgBa ₂ CaCu ₂ O _y	HTS	KrF	Higuma et al. 1994
PrBa ₂ Cu ₃ O _{7-x}	HTS	KrF	Mercey, et al. 1995
MoN _x , NbN _x , SnSi	LTS	KrF	Treece et al. 1994
La _{1-x} Sr _x MnO _z	Magnetic recording	KrF (248)	Ju et al. 1994
CoO, Co ₃ O ₄	Magnetic recording	KrF (248)	Feiler et al.
Fe ₃ O ₄	Magnetic recording	Nd:YAG (1.06)	Choi, H.S.; et al.
Bi ₃ Fe ₅ O ₁₂	Magnetic recording	KrF (248)	Simon, et al.
Nd _{0.7} Sr _{0.3} MnO ₃	Magnetic recording	KrF	Xiong et al. 1995

Material	Comment	Laser	Reference
$\text{Co}_x\text{Cu}_{1-x}$	Magnetic recording	KrF (248)	Huai, Y.; et al. 1994
$\text{La}_{1-x}\text{Sr}_x\text{MnO}_3$	Magnetic recording		Krishnan et al, 1995
$\text{La}_{0.7}\text{Ca}_{0.3}\text{NbO}_3$	Magnetic recording	KrF	Hundley et al. 1995
EuS, EuSe, EuTe	magnetic semiconductors	KrF (248)	Mulloy et al, 1993
FeSiGaRu	magnetic	KrF	van de Riet et al. 1993
LaNiO_3	paramagnetic & SNS barrier	KrF (248)	Satyalakshmi et al. 1993
MnSb	Ferromagnetic		Shvets et al. 1992
LiFeO_3	magnetic	KrF	Oliver et al. 1994
$\text{Pb}_{1-x}\text{La}_x\text{Ti}_{1-x/4}\text{O}_3$	Ferroelectric	KrF (248)	
$\text{Bi}_2\text{VO}_{5.5}$	Ferroelectric	ArF (193)	Beesabathina et al. 1994
CaTiO_3	Ferroelectric	Ar F (193)	Tabata, et al. 1995a
Ca:SrTiO ₃ , Zr:SrTiO ₃	Ferroelectric	KrF	Knauss et al. 1995
Nb:Bi ₄ Ti ₃ O ₁₂ , La:Bi ₄ Ti ₃ O ₁₂	Ferroelectric	KrF (248)	Lampe 1994
Mg:PbTiO ₃ Nb:PbTiO ₃	Ferroelectric		Uusimiki, et al 1994
Bi:YIG	magneto-optic	ArF (193)	Kidoh, et al. 1994
RbTiOPO ₄ , RbRiOPO ₄	nonlinear optical	KrF (248)	Liu, et al. 1994
$\text{Ba}_2\text{NaNb}_5\text{O}_{15}$	electro-optic	KrF (248)	Liu, J. et al. 1994.
LiTaO_3	electro-optic	KrF (248)	Liu, J. et al. 1994b
KNbO_3	electro-optic	KrF (248)	Zaldo, et al. 1994
GaN	electro optic	KrF (248)	Leuchtner et al. 1995
KTiOPO ₄	non-linear optic	KrF	Xiong et al. 1994
FeSi_2	optoelectronics	KrF (248)	Olk et al. 1994
Nd:YAG	optical waveguides		Ahmed et al. 1995
MgF_2 , CaF_2 , LaF_3 , SrF_2	AR coatings	CO_2	Cheung et al. 1992
Er_2O_3	optical	ArF (193)	Sanchez et al. 1994
$7\text{Ga}_2\text{S}_3 \cdot 3\text{La}_2\text{S}_3$	IR optics	KrF (248)	Youden et al. 1993

Material	Comment	Laser	Reference
VO ₂ , V ₃ O ₅ ,	IR Detectors	ArF	Kim et al. 1994
MnTe	electro optics	Nd:YAG	Misiewicz et al. 1993
CdMnTe	magnetic sensor		Debowski, 1995
TaC			Teghil et al. 1994
AlN	dielectric		Vispute, et al. 1995
Si ₃ N ₄	dielectric	ArF (193)	Fogarassy et al. 1994
Teflon	friction	KrF	Blanchett, et al. 1993
NiS			Lee et al. 1993
CoSi ₂	buffer layer	KrF (248)	Kumar et al. 1991
FeSn, FeHf, FeAl, FeMn, FeNi, FeTi, FeCr, FeCr, FeNb, FeTa	inter-metalics	KrF	Krebs et al.; 1993
Cu-Ni, Ag-Ni	intermetalics	ArF (193)	van Ingen et al. 1994
CoCrTa, CoCrPt	intermetalics	KrF (248)	Ishikawa et al. 1994
BaZrO ₃	thermoelectric conversion	KrF	Leuchtner et al. 1994
mordenite, faujafite zeolite structures	sensors, gas seperation	Nd:YAG (532)	Dye et al. 1995
(Zr, Sn)TiO ₂			Tabata et al. 1995b
β-FeSi ₂			Panzner, et al. 1995
LiTaO ₃	Acoustics	ArF (193)	Shibata, et al. 1993
AgGaS ₂	semiconductor	XeCl (308)	Uchiki et al. 1993
Human Collagen	Skin repair	KrF	Conklin, et al. 1995
NbTe _x			Grangeon et al. 1995
ErO ₂			Queralt, et al. 1995
polyperinaphthanl ene			Yudasaka et al. 1994
CoSi ₂			Glebovsky, 1994a
WSi ₂			Glebovsky, et al. 1994b

References for Appendix A:

- Ahmed, K.; Mukherjee, P.; Witanachchi, S.; to be presented at the Fall MRS Meeting, Boston, MA, Dec. 1995.
- Allen, J.L., Mercey, B., Prellier, W., Hamet, J.F., Hervieu, M. and Raveau, B., *Physica C*, vol. 241 No. 1-2, pp. 158-166, 1995.
- Antaya, M.; Cearn, K.; Preston, J.S.; Reimers, J.N.; and Dahn, J.R.; *J. Appl. Phys.*, **76**, pp 2799-2806, 1994.
- Bauer, S.; Beckers, L.; Fleuster, M. Schubert, J. Zander, W.; and Buchal, Ch.; *Mat. Res. Soc. Symp. Proc.* **Vol. 341**, pp. 283-288, 1994.
- Beesabathina, D. P.; Salamanca-Riba, L.; Hegde, M.S.; Satyalakshmi, K.M.; Prasad, K.V.R.; and Varma, K.B.R.; *Mat. Res. Soc. Symp. Proc.*; **Vol. 341**, pp. 399-404, 1994.
- Choi, H.S.; Ahn, J.S.; Jo, J.; Noh, T.W.; Chun, S.H. Chun, and Khim, Z.J.; *Mat. Res. Soc. Proc.* **Vol. 341**, pp.35-40, 1994.
- Cheung, J.T.; Sankur, H.; and Chang, T.; *Optics and Photonics News*, pp. 25-27, June, 1992.
- Conklin, J.A.; Cotell, C.M.; To be presented at the Fall MRS Meeting, Boston, MA, Dec. 1995.
- Debowski, J.J., Lebecki, K., and Buchanan, M., *Proceedings of the IEEE Instrumentation and Measurement Technology Conference*, Irvine, CA, May 1993, published 1995.
- Dye, R.; and Peachey, N.; *Laser Focus World*, pp. 9, May, 1995.
- Feiler, D.; and Williams, Stanley, *Mat. Res. Soc. Symp. Proc.* **Vol. 341**, pp.29-34, 1994.
- Foggarassy, E.; Fuchs, C.; Slaoui, A.; de Unamuno, S.; Stoquert, J.P.; Marine, W.; and Lang, B.; *J. Appl. Phys.* **76**, pp 2612-2620, 1994.
- Glebovsky, V.G., Oganyan, R.A., Ermolov, S.N., and Kolosova, E.V., *Thin Solid Films* **Vol. 248**, No. 2. pp. 145-148. 1994a.
- Glebovsky, V.; Ermolov, S.; Oganyan, R. and Kolosova, E.; Presented at the Fall MRS Meeting, Boston, Dec. 1994b.
- Grangeon, F., Sassoli, H., Mathey, Y., Autric, M., Pailarey, D., and Marine, W., *Applied Surface Science*, **Vo. 86**, pp. 160-164, 1995.
- Greer, J.A.; Van Hook, H.J.; Tabat, M.D.; Nguyen, H.Q.; Gammie, G.; and Koufopoulos, P.F.; *Mat. Res. Soc. Symp. Proc.* **Vol. 345**, pp. 281-288, 1994.

- Greer, J.A.; Tabat, M.; *Mat. Res. Soc. Symp. Proc. Vol. 341*, pp. 87-94, 1994b.
- Higuma, H. Miyashita, S.; and Uchikawa, F.; *Appl. Phys. Lett.* **65**, pp. 743-745, 1994.
- Hirata, G.A.; Lopez, O.A.; Shea, L.E.; Yi, J.Y.; McKittrick, J. Cheeks, T.; to be presented at the 42nd National Symposium of The American Vacuum Society, Minneapolis, MN, October, 1995.
- Huai, Y. Chaker, M.; Pepin, H.; Boily, S.; Bian, X.; and Cochrane, R.W.; *J. of Magnetism and Magnetic Materials*, 1994.
- Hundley, M.F.; Hawley, M.; Heffner, R.H.; Jia, Q.X.; Neumeier, J.J.; esmer, J.; Thompson, J.D.; and Wu, X.D.; *Appl. Phys. Lett. Vol. 67*, pp. 860-862, 1995.
- Ishikawa, A.; Tanahashi, K.; Yahisa, Y.; Hosoe, Y.; and Shiroishi, Y.; *J. Appl. Phys.* **75** pp. 59785980, 1994.
- Jo, W.; Kim, K.H.; Noh, T.W.; Kwon, S.D.; and Choe, B.D.; *Mat. Res. Soc. Symp Proc. Vol. 361*, pp. 33-38, 1995.
- Ju, H.L.; Kwon, C.; Li, Qi, Greene, R.L.; Venkatesan, T.; *Appl. Phys. Lett.* **65**, pp. 2108-2110, 1994.
- Kang, Y.M.; Ku, J.K.; and Baik, S.; *Mat. Res. Soc. Symp. Proc. Vol. 361*, pp. 569-574, 1995.
- Kidoh, H.; Yashima, H.; Morimoto, A.; and Shimizu, T.; *Jpn. J. Appl. Phys. Vol. 33*, pp. 4094-4099, 1994.
- Kim, D.H.; and Kwok, H.S.; *Appl. Phys. Lett.* **65**, pp. 3188-3190, 1994.
- Knauss, L.A.; Pond, J.M.; Treece, R.E.; Horowitz, J.S.; Mueller, c.H.; Donovan, E.P.; and Chrisey, D.B.; to be Presented at the Fall MRS Meeting, Boston, MA, Dec. 1995.
- Krebs, H.; Bremert, O.; *Appl. Phys. Lett.* **62**, pp. 2341- 2343, 1993.
- Krishnan, K.M.; Modak, A.R.; to be presented at the Fall MRS Meeting, Boston, MA, Dec. 1995.
- Kumar, A.; and Naryan, J.; *Appl. Phys. Lett.* **59**, pp. 1785-1787, 1991.
- Lampe, D. R.; Westinghouse Electric Corp. Final Report, DARPA Contract # N00014-90-C-0159, 1994.
- Lee H.; Kanai, M.; Kawai, T.; and Kawai, S.; *Jap. Journ. Appl. Phys. Part 1, Vol. 32*. pp. 2100-2100, 1993.
- Leuchtner, et al. Unpublished Results, 1994.

- Leuchtner, R.E.; Hristakos, L. Borck, W. and Li, Y.; to be presented at the Fall MRS Meeting, Dec. 1995.
- Levoska, J.; Hill, A.E.; Leppavuroi, S.; Kusmartseva, O.; Tomlinson, R.D.; and Pilkington, R.D.; Jpn. J. Appl. Phys. Vol. 32, pp. 32-33, 1993.
- Liu, J.M.; Zhang, F.; Liu, Z.G.; Zhu, S.N.; Shi, L.J.; Wu, Z.C.; and Ming, N.B.; Appl. Phys. Lett. **65**, pp. 1995-1997, 1994a
- Liu, J.M.; Liu, Z.G.; Zhang, M.S.; Zhu, S.N.; Wu, Z.C.; J. Phys. Condens. Matter. **6**, pp. 5409-5414, 1994.
- Liu, Z.G.; Liu, J.M.; Ming, N.B.; Wang, J.Y.; Liu, Y.G.; Jiang, M.H.; J. Appl. Phys. **76**, pp. 8215-8217, 1994.
- Mathews, S.A.; Pique, A.; and Mathur, M.; Presented at the Spring MRS Meeting, April, San Fransisco, 1994.
- Mercey, B.; Gupta, A.; Hervieu, M.; and Raveau, B.; Journal of Solid State Chemistry, Vol. **116**, no. 2, pp. 300-306, 1995.
- Misiewicz, J.; Huber, C.; Heiman, D.; Vu, T.Q.; Applied Surface Science **69**, pp. 156-160, 1993.
- Mulloy, M.P.; Blau, W.J.; and Lunney, J.G.; J. Appl. Phys. **73**, pp 4104-4106, 1993.
- Niu, C.; Lu, Y.Z.; and Leiber, C.M.; Science, Vol. 261. pp. 334-336, 1993.
- Oliver, S.A., Vittoria, C., Galestrino, G., Martellucci, S., Petrocelli, G., Tebano, A., and Paroli, P., IEEE Transactions on Magnetics, Vol. 30, No. 6, PP 4933-4935, 1994.
- Olk, C.H.; Karpenko, O.P.; Yalisove, S.M.; Doll, G.L.; and Mansfield, J.F.; J. Materi. Res.; Vol. 9, #11, pp 2733-2736, 1994).
- Panzner, M.; Mai, H.; Schoeneich, B.; Selle, B.; Lange, H.; Henrion, W.; Wittke, T.; Lenk, A.; Teresiak, A.; and Groetzxchel, R.; Materials Science Forum Vol. 173-174, pp. 123-128, 1995.
- Phillips, J.M.; Kwo, J.; Thomas, G.A.; Carter, S.A.; Cava, R.J.; Hou, S.Y.; Krajewski, J.J.; Marshall, J.H.; Peck, W.F.; Rapkine, D.H.; and van Dover, R.B.; Appl. Phys. Lett. **65** (1), pp. 115-117, 1994.
- Queralt, X., Ferrater, C., anchez, F., Aguiar, R., Palau, J., and Varela, M., Spplied Surface Science, Vol. **86**, pp. 95-98, 1995.
- Rao, R., Pinto, R., Purandare, S. C., Apte, P.R., Gupta, L.C., Vijayaraghavan, R., Datar, B.S., and Shirodkar, V.S., Superconductor Science & Technology, Vol. **8**, No. 2, pp. 108-111, 1995.

Sanchez, F.; Queralt, X.; Ferrater, C.; Aguiar, R.; and Varela, M.; *Vacuum* **Vol. 45**, pp. 1129-1130, 1994.

Simion, B.M.; Ramesh, R.; Keramidas, V.G.; Pfeffer, R.L.; Thomas, G. and Marinero, E.; *Mat. Res. Soc. Symp. Proc. Vol. 341*, pp. 65-70, 1994.

Sung, G.Y.; Suh, J.D.; and Nahm, S.; *Mat. Res. Soc. Symp. Proc. Vol. 341*. pp. 177-182, 1994.

Satyalakshmi, K.M.; Mallya, R.M.; K.V.Ramanathan, Wu, X.D.; Brainard, B.; Gautier, D.C.; Vasanthacharya, N.Y.; and Hegde, M.S.; *Appl. Phys. Lett.* **62**, pp 1233-1235, 1993.

Shibata, Y.; Kaya, K.; and Akashi, K.; *Appl. Phys. Lett.* **62**, pp. 3046-3048, 1993.

Shevets, I.V.; Cugat, O.; Lunney, J.G.; Coey, J.M.D.; *Journal of Appl. Phys.*, **Vol. 73**, pp 6845, 1992.

Stangl, E., Proyer, S., and Hellebrand, B., *Physica C*, **Vol. 243**, No. 1-2, pp. 69-75, 1995.

Tabata, H.; Tanaka, H.; Kawai, T.; *Mat. Res. Soc. Symp. Proc. Vol. 361*, pp. 533-538, 1995a.

Tabata, H.; Toyota, Y.; Kobayaski, M.; Yoshino, Y.; Katayama, Y.; Kawai, T.; to be presented at the Fall MRS Meeting, Boston, MA,, 1995b.

Tarsa, E.J.; Speck, J.S.; and Robinson, McD.; *Appl. Phys. Lett.* **63**, pp. 539-541, 1993.

Teghil, R, D'Alessio, L.; De maria, G.; and Ferro, D.; Presented at the E-MRS Spring Conference, Symposium B, Strasbourg, France, May, 1994.

Treece, R.E.; Horowitz, J.S.; Claassen, J.H.; and Chrisey, D.B.; *Appl. Phys. Lett.* **65**, pp. 2860-2862, 1994.

Uchiki, H.; Machida, O.; Tanaka, A.; and Hirasawa, H.; *Jpn. J. Appl. Phys.* **Vol. 32**, pp L764-L766, 1993.

Uusimiki, A. Zhang, HX.; Leppavuori, S>, Moilanen, H.; and Rautioaho, R.; *Ferroelectrics Letters Section*, Vol. 17, no. 5-6, pp. 105-110, 1994.

van der Reit, E.; Kools, J.C.S.; and Dieleman, J.; *Journal of Appl. Phys.*, **Vol. 73**, pp 8290-8286, 1993.

van Ingen, R.P.; Fastenau, R.H.J.; and Mittemeijer, E.J.; *J. Appl. Phys.* **76**, pp. 1871-1873, 1994.

Vispute, R.D.; Wu, H.; Jagannadham, K.; and Naryan, J.; To be presented at the Fall MRS Meeting, Boston, MA, Dec. 1995.

Xiong, G.C.; Li, Q.; Ju, H.L.; Greene, R.L.; Venkatesan, T.; To be presented at the Fall MRS Meeting, Boston, MA, Dec. 1995.

Xiong, F., Hagerman, M., Zhou, H., Kozhevnikov, V., Wong, G.K., Poeppelmeier, K., Ketterson, J.B., Chang, R.P.H., and White, C.W., *Journal of Vacuum Science and Technology A*, Vol. 12, No. 4, pt. 1, pp. 1446-1450, 1994.

Yadasaka M., Tasaka, Y., Tanaka, M., Kamo, H., Ohki, H., Usami, S., and Yoshimura, S., *Appl. Phys. Lett.*, **64**, pp. 3237-3239, 1994.

Youden, K.E.; Grevatt, T.; Eason, R.W.; Rutt, H.N.; Deol, R.S.; and Wylangowski, G.; *Appl. Phys. Lett.* **63**, pp. 1601-1603, 1993.

Youden, K.E.; Thony, S.S.; Hesselink, L.; and Harris Jr. J.S.; *Mat. Res Soc. Symp. Proc. Vol. 361*, pp. 173-178, 1995.

Yoshimoto M, T. Arakane, T. Asakawa, K. Horiguchi, K. Hirai, and H. Koinuma, *Jpn. J. Appl. Phys. Vol 32 (1993)* pp. L 1081 - L 1084.

Zaldo, C.; Gill, D.S.; Eason, R.W.; Mendiola, J.; Chandler, P.J.; *Appl. Phys. Lett.* **65**, pp. 502-504, 1994.