

Responsibility for all statements in this paper rests with the authors. • All rights reserved. • For permission to publish write ISA, 530 Wm. Penn Place, Pittsburgh, Pa. 15219

*In NASA
N66-29355*

DEVELOPMENT OF ABLATION SENSORS FOR ADVANCED REENTRY VEHICLES

By Peter J. LeBel and James M. Russell III

NASA Langley Research Center
Langley Station, Hampton, Va.

DISSEMINATION STATEMENT A

Approved for public release;
Distribution Unlimited

Presented at the Instrument Society of America
20th Annual ISA Conference and Exhibit

19960419 001

DEPARTMENT OF DEFENSE
PLASTICS TECHNICAL EVALUATION CENTER
PICATINNY ARSENAL, DOVER, N. J.

Los Angeles, California
October 4-7, 1965

DTIC QUALITY INSPECTED 1

PLASTIC
9009

DEVELOPMENT OF ABLATION SENSORS FOR ADVANCED REENTRY VEHICLES

By Peter J. LeBel and James M. Russell III
Aerospace Technologists
NASA Langley Research Center
Langley Station, Hampton, Va.

ABSTRACT

Three sensors to measure the ablation parameters of advanced heat-shield materials during reentry have been developed by the Instrument Research Division of the NASA Langley Research Center.

The make wire sensor is designed to measure rate of recession of the char layer interface in a charring ablator, while the light pipe and spring wire sensors are designed to measure material surface recession rates. These sensors have been extensively tested in arc-jet facilities to evaluate their performance in a simulated reentry heating environment. The results of these tests indicate that each of the three types is capable of measuring material surface (or char interface) position to an accuracy in the order of 0.01 inch. The sensors have been flight tested on a Scout reentry vehicle in a nosecone of the Project Apollo heat-shield material at heating conditions approximating those to be encountered during atmospheric reentry from a lunar mission.

This paper will describe the design and mode of operation of the make wire, light pipe, and spring wire sensors and the results of the development program undertaken to qualify them for flight.

INTRODUCTION

The increasing number of manned space missions emphasizes the importance of extensive and often sophisticated instrumentation to monitor the many systems in the spacecraft and insure its safe return to earth. One of the most important of these systems is the ablative heat shield which gives the spacecraft and its occupants thermal protection during the critical period of reentry into the earth's atmosphere. In order to assess the thermal protection efficiency of a heat shield, instrumentation is needed to measure the thermal and physical changes which occur in the heat shield during the reentry period. Ablation sensing instrumentation is also a useful tool in the ground development and evaluation of thermal-protection materials.

Figure 1 is a photograph of a cross section of a typical charring ablator and serves to illustrate the measurement regions of interest.

Desirable measurements include rate of recession of the ablator surface, rate of recession of the interface between the char layer and the virgin material, surface temperature, and temperature gradients through the material. Important characteristics of any ablation sensor are that it accurately and reliably measure one or more of these parameters with a minimum effect on the thermal properties of the heat shield.

ABLATION SENSING TECHNIQUES

Recognizing the importance of ablation information, a survey was conducted to determine the feasibility of developing flight instrumentation to make the required measurements. All known existing sensor techniques and several new and unique suggestions were studied. Based on this survey, it was decided to pursue the development of three of these techniques which appeared to overcome some of the basic measurement problems. These were the make wire sensor to measure rate of recession of the char layer interface and the light pipe and spring wire sensors to measure ablator surface recession rate. The development and operation of these sensors is described in detail in the following paragraphs.

MAKE WIRE ABLATION SENSOR

Many of the recently developed ablation materials, when subjected to heat, decompose and form a residue or "char" which exhibits a high electrical conductivity. The make wire sensor utilizes this high conductivity to provide a measurement of the position of the interface between the char and virgin material as a function of time.

The sensing element consists of a pair of electrically open circuited wires imbedded in the ablation material. During the ablation process, the char interface reaches the location of the sensor and the resistance between the wires decreases. This impedance change is used to actuate electronic circuitry which provides the proper signal for the spacecraft telemetry system. Up to eight pairs of wires stepped in depth in a single plug of ablator provide a measure of char interface recession rate.

Important advantages of this device are its simplicity, inherent reliability, and ability to withstand the severe environment associated with space vehicles. In addition, the sensor is not affected by the ionized plasma surrounding a reentry vehicle, and the effects of the sensor upon the thermal and physical properties of the ablation material have been minimized.

Figure 2 is a photograph showing the various stages of assembly of the make wire sensor. The sensing elements are fabricated from 10-mil-diameter platinum wire. Platinum was chosen because when heated, it does not form an insulating oxide which would interfere with the wire-to-char contact. A 30-mil-diameter head is formed on one end of the wire. This provides large surface area to insure good contact with the char with a minimum of foreign material imbedded in the heat shield. A cylindrical plug of ablator is machined into three sections. Pairs of wires are fitted into 10-mil grooves machined into the center section at each depth. The three sections of ablator are then bonded together with epoxy resin to form a cylindrical plug. Up to eight pairs of wires may be inserted in an 0.5-inch-diameter plug of ablator in this manner.

The sensor plug is attached to a bakelite cartridge which contains mounting rings fabricated from printed circuit board. One ring provides a common connection for one wire of each pair. The second ring provides a mounting lug for the second wire of each pair and for shielded lead wires. Resistors (100 K Ω) are soldered between the mounting rings to provide a means for checking sensor lead continuity. The entire assembly is bonded to the sensor plug and filled with epoxy resin. The completed sensor is then bonded into and made an integral part of the heat shield.

Figure 3 is a schematic of the signal conditioning circuitry developed for the make wire sensor. This circuitry was designed around a bistable solid state switch (Q_2) which becomes conducting with a small positive potential change at its input and thereafter remains conducting regardless of any further positive or negative change at the input. Circuit operation may be explained as follows: As the char layer reaches the sensor, the resistance between the wires begins to decrease causing Q_1 's base-to-collector potential to decrease. When this voltage reaches a predetermined level, Q_1 conducts, current flows into the base of Q_2 which conducts, and voltage is produced at terminal E. Incorporation of transistor Q_1 permits operation of the sensor at ground potential and eliminates the possibility of shorting the power supply should the char become grounded. Use of this circuitry minimizes variations in sensor output due to char contact resistance and, in addition, reduces any possible effects that the random variations of the ionized plasma might have on sensor output. Each circuit element requires a volume of 0.2 cubic inch, weighs 0.2 ounce, and requires 30 milliwatts of power.

Each sensing element and associated signal conditioning circuit will yield one data point of char interface recession. Several data points when plotted together describe the rate of recession of the char layer interface.

LIGHT PIPE ABLATION SENSOR

The light pipe ablation sensor utilizes a high melting point optical fiber to channel the light present at the surface of an ablating heat shield to a photoresistive diode located at a remote, lower temperature point in the ablator. The changing resistance of the diode, as a result of the light input, is used to provide a measurement of material surface recession.

When the ablation process occurs (fig. 4), the area above the end of the light pipe becomes a source of radiation. As the material surface ablates, this area approaches the end of the light pipe causing an increase in the light transmitted to the photodetector, as shown by the diode current versus time curve. A predetermined current level (I_1 in fig. 4) which can be used to correlate surface position with time is selected experimentally. Several sensors at various depths in the ablator will provide surface position data which can be correlated with time to yield recession rate.

The infrared rejection filter is designed to improve sensor accuracy by making it less sensitive to the infrared emission (wavelengths longer than 0.7 micron) from the low temperature area near the char layer interface.

Small physical size coupled with light weight is achieved in the fabrication of the sensor. The measurement is unaffected by the ionized plasma surrounding a reentry body or by the electrical conductivity of the char layer. In addition, the effect of the light pipe sensor on the thermal and physical properties of the material has been minimized.

The sensor elements are imbedded in the 1/4-inch-diameter plug of the ablation material. Figure 5 shows the light pipe sensor in both dismantled and assembled states. The light pipe material used is 0.016-inch-diameter synthetic white sapphire (Al_2O_3). The selection of this material was based upon its high melting point (3700° F) and mechanical strength characteristics. The selection of an infrared filter material was based on a consideration of the desired spectrum to be filtered (wavelengths longer than 0.7 micron). The photodetector is a silicon photoresistive diode that decreases in resistance with increasing light intensity incident upon a photosensitive crystal. This particular device was chosen because of its small physical size (0.080 inch diameter), high operating temperature capability (250° F), and spectral response.

An alternate configuration employs as many as six sensing elements in a single 0.5-inch-diameter plug of ablation material. The disadvantage of this fabrication technique is the lack of a method to check the calibration of completed sensors.

The signal conditioning circuitry developed for the light pipe sensor is similar in design and operation to the make wire sensor circuitry previously described.

The practicability of the light pipe sensor as a temperature indicator has been investigated and the measurement appears feasible. Preliminary tests involved the use of a light pipe sensor and an iridium-iridium rhodium thermocouple installed at the same depth in a specimen of ablator. The light pipe sensor was calibrated in terms of temperature by use of a tungsten source to approximate black body radiation. The data showed that the light pipe sensor and thermocouple outputs tracked each other well but were separated by 300° F. These results indicate that the major development problem may be establishment of a technique for accurately calibrating the sensor output in terms of temperature. The advantage of such a device would be measurement of temperature to 3700° F in a reentry environment and large signal output (5 volts) with no amplification.

SPRING WIRE SENSOR

Ablation sensors must generally be custom designed for a particular application or a specific material. The spring wire sensor, however, is designed to obtain a measurement of ablation material surface recession rate in a wide variety of charring and noncharring ablators.

The spring wire sensor (fig. 6) consists of a metal tube attached to a snap action switch. A 0.003-inch-diameter tungsten wire is fixed to the leaf spring of the switch, passed through and attached to the end of the tube with the spring held in tension. The tubing is imbedded in the ablator at the desired depth shown as "a" and the switch assembly (occupying a volume of 0.1 cubic inch) is fastened to the ablator substructure with mounting screws. As the material ablates to the location of the sensor the very steep temperature gradient at and just beyond the surface softens the tubing and releases the wire, allowing the switch to close. The output from a series of these units stepped in depth in the ablator will measure material surface recession rate when correlated with time.

The spring wire sensor measurement is unaffected by the ionized plasma or by the electrical conductivity of the char layer. Also, since the sensor output is a positive switch closure, only a simple voltage divider resistance network is needed to provide the proper signal for the telemetry system.

The choice of material for the support tube is dictated by the expected surface temperature of the ablator; 0.020-inch OD tungsten-rhenium tubing has been used successfully with high-temperature ablators such as the Apollo heat-shield material. For lower temperature ablators, molybdenum, aluminum, and stainless-steel tubing have been used successfully; 0.003-inch-diameter tungsten wire has worked well as the spring wire. Figure 7 is a photograph of the spring wire sensor assembly showing both a single sensor and a ganged assembly of four sensors.

The length of wire or support tubing and the configuration of the switch may be altered to conform to the configuration of the flight payload without affecting the operation of the sensor. An alternate approach to the sensor design is to eliminate the support tube and anchor the wire directly to a fine metal disk imbedded in the ablator. The operation of the sensor in this case is the same as previously described, the material surface reaches the location of the sensor, the disk melts and releases the wire allowing the switch to close. This design has been successfully used in materials such as Teflon which do not form a weak char layer during ablation.

DEVELOPMENT TEST PROGRAM

The program which was undertaken to develop and qualify ablation sensors for flight included feasibility tests using an oxygen-acetylene torch and arc-jet tests for the best possible ground simulation of the reentry heating environment. Each of these tests is described briefly in the following paragraphs.

Feasibility Tests

To obtain an indication of the practicability of various ablation sensing techniques, laboratory tests were conducted using an oxygen-acetylene torch as the heat source. For these tests a single sensor plug was imbedded in a 3/4-inch-diameter ablator sample. Heating conditions were varied by adjusting nozzle size, distance from nozzle to sample, and gas composition. Sensor output was observed on a recording oscillograph. Heating rates from 100 to 300 Btu/ft²-sec and run times to 80 seconds were obtained.

The results of these tests indicated the feasibility of make wire, light pipe, and spring wire measurements in several advanced ablation materials and established the basic sensor design. To determine precise system accuracies in a more realistic oxidizing environment and one that better simulates reentry heating, arc-jet tests were conducted.

Arc-Jet Tests

Tests have been conducted in Langley Research Center electric arc jet facilities. The advantages of these tests include the ability to carefully control test conditions, large specimen size which permits the simultaneous test of several sensors, and most important, the arc jet provides a better ground simulation of the reentry heating environment.

The make wire, light pipe, and spring wire sensors were tested in a variety of advanced ablators. All of these materials were charring composites which consisted of phenolic, epoxy, or other resins filled with organic or inorganic materials in the form of powder, fibers, or microballoons. The results of these tests indicate the general applicability of these techniques to this class of materials.

To date more than 60 ablation sensor tests have been conducted in the arc-jet facilities at heating rates from 80 to 800 Btu/ft²-sec in various gaseous environments with stream temperatures up to a maximum of 7,000° F.

Ground Test Results

As an example of the test procedure, figure 8 is a plot of the results of an arc-jet test of a 3-inch-diameter specimen of low-density Apollo type ablator containing make wire and light pipe sensors. The heating rate was 100 Btu/ft²-sec with air as the heating environment. Plotted is material thickness of the specimen in inches versus test time in seconds. The specimen was subjected to the stream until the recession caused the last sensor to be activated. At this time, the specimen was removed from the jet. The final location of the surface (or char layer interface) as predicted from the data is compared with the micrometer-measured position to obtain sensor accuracy. In this case, for the light pipe sensors as an example, the predicted material thickness from the data was 0.79 inch and the micrometer-measured thickness was 0.80 inch yielding an accuracy of 0.01 inch. Similar measurements can be made for the make wire sensor. The Y-axis separation between the curves represents the changing thickness of the char layer as a function of time.

It should be emphasized that using this technique, only the last data point can be checked for accuracy. Photographic techniques have been employed in an effort to obtain a continuous correlation of recession with time with limited success. The accuracy of the film data is uncertain for two reasons. First, the specimen may ablate at an angle, or may burn more rapidly at the center than at the edges. This type of ablation cannot be detected optically. Second, variations in the index of refraction due to the hot gases may mask the true surface location. Because of these limitations, other techniques for externally

monitoring material ablation in the ground facility are being studied.

Figure 9 illustrates the data from a test of a 3-inch-diameter Apollo type ablator specimen instrumented with four spring wire and four light pipe sensors. This test was conducted at a heating rate of 200 Btu/ft²-sec in air. Once again, material thickness of the specimen in inches versus test time in seconds is plotted. Both sensors predicted the final surface location to within 0.01 inch of the actual measured position, and the maximum separation or deviation between the two curves at any time is less than 0.01 inch.

These results, typical of many arc-jet tests over a wide range of test conditions, indicate that the make wire, light pipe, and spring wire sensors are capable of measurements in the order of 0.01 inch in several advanced ablation materials.

Flight Tests

The final phase of the sensor development program includes an evaluation of the sensor performance in a reentry environment. To date, one such flight test has been completed. Four sensors of each type were installed in LRC Scout Reentry payload R-4 in a nose cap of the Apollo heat-shield material and boosted to a reentry velocity of 28,000 feet per second. The data indicated that both the make wire and spring wire sensors functioned properly and provided information on the recession rate of the Apollo ablator. Three of the four light pipe sensors malfunctioned and it has been concluded that this malfunction was due to an error in payload wiring rather than a sensor failure. Details of the R-4 flight test are contained in a classified NASA Technical Memorandum.

Several additional sensor flight tests are planned with a variety of advanced ablaters under flight conditions varying from a simulated lifting reentry to a trajectory which will simulate reentry from a lunar mission. Some of the payloads will be recoverable to permit a detailed examination of the material and instrumentation that has been subjected to the reentry environment.

CONCLUSIONS

Three sensors to measure the in-flight thermal parameters of an ablative reentry vehicle heat shield have been developed at the NASA-Langley Research Center. These include the make wire sensor to measure rate of recession of the char layer interface and the spring wire and light pipe sensors to measure surface recession rate. The results of extensive ground tests in arc-jet facilities indicate a measurement accuracy in the order of 0.01 inch for each of the three

types. The ablation sensors have undergone complete environmental tests and have been flight tested in a reentry environment in a nose cap of the Apollo heat-shield material.

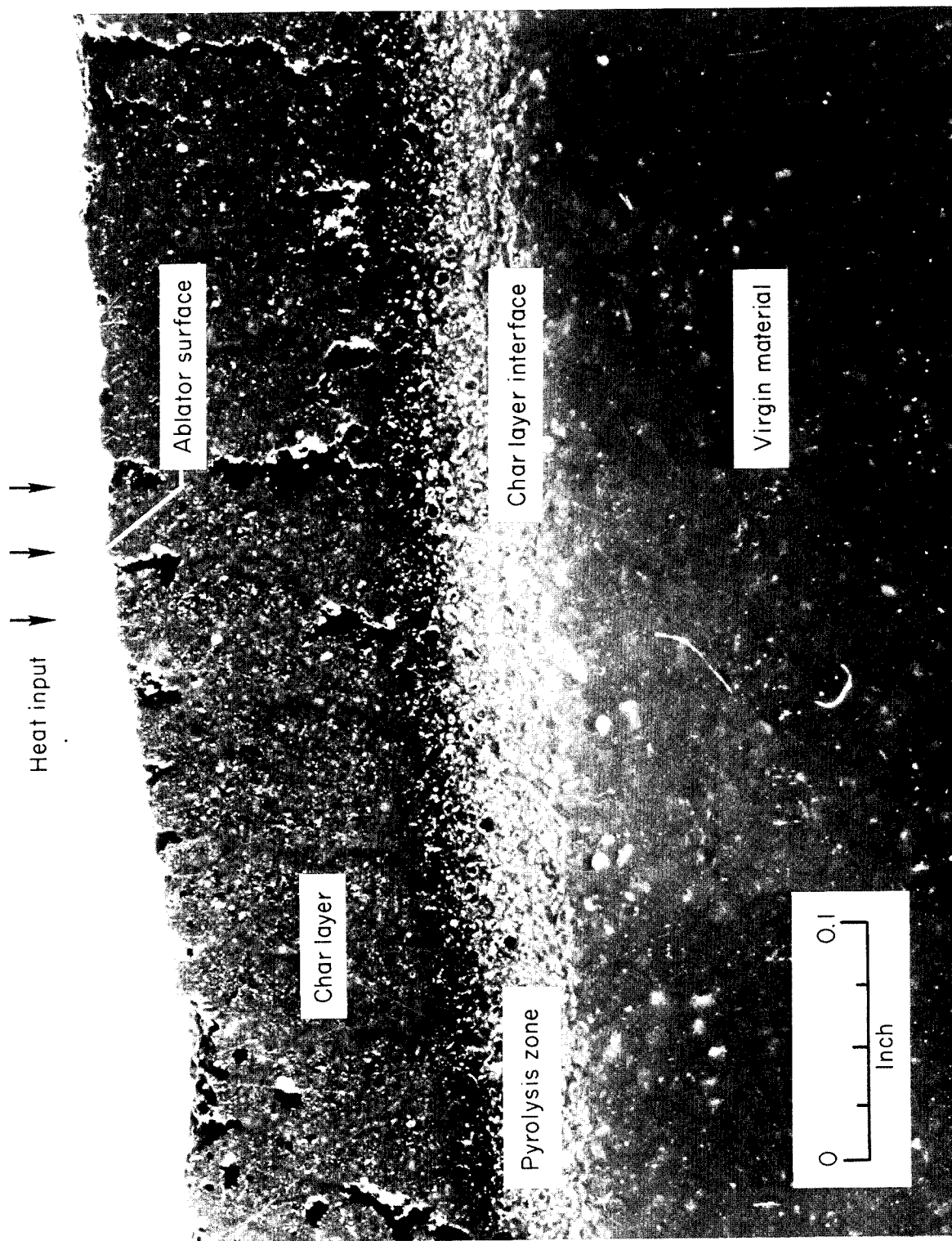

Figure 1.- Typical charring ablator.

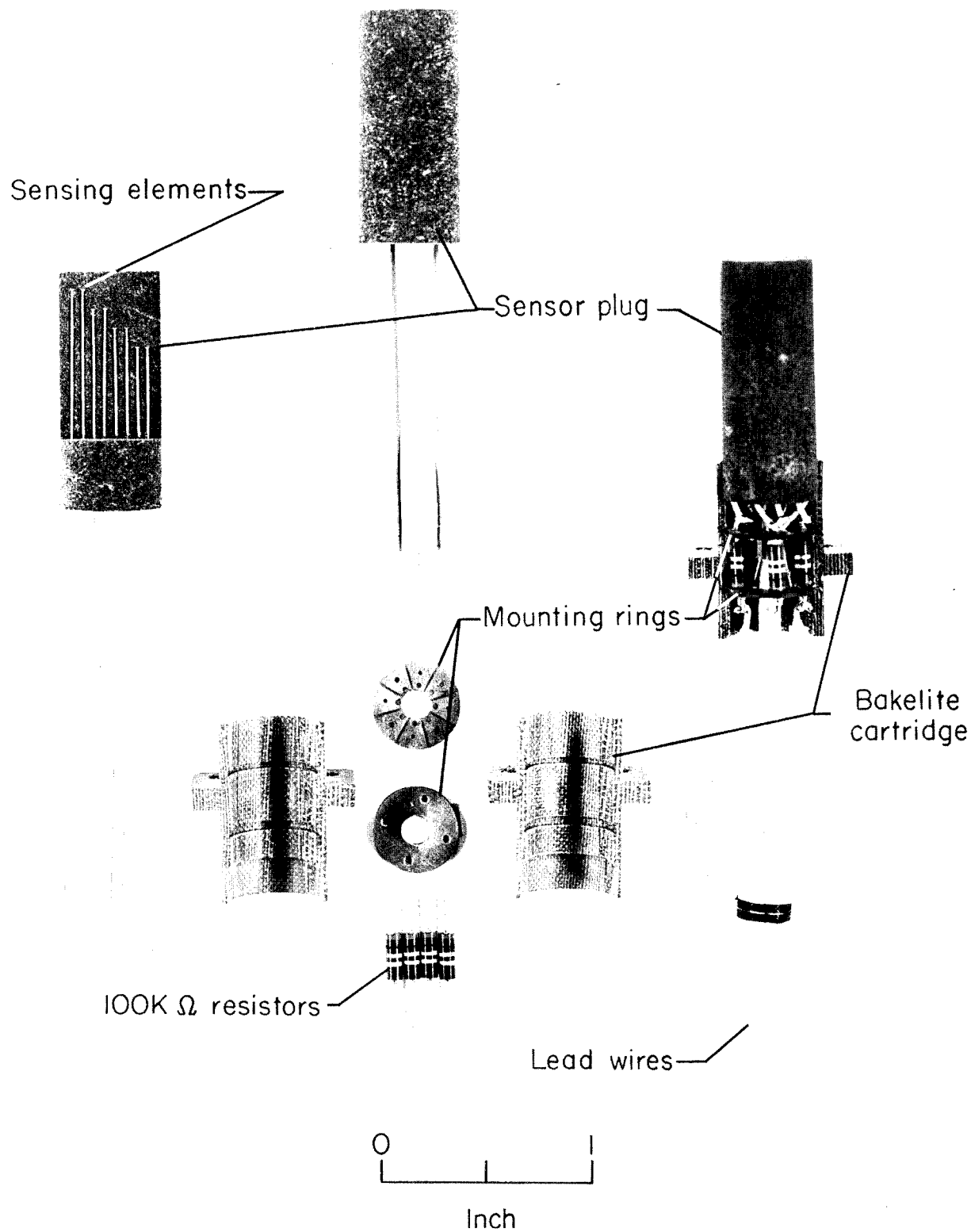

Figure 2.- Make wire sensor assembly.

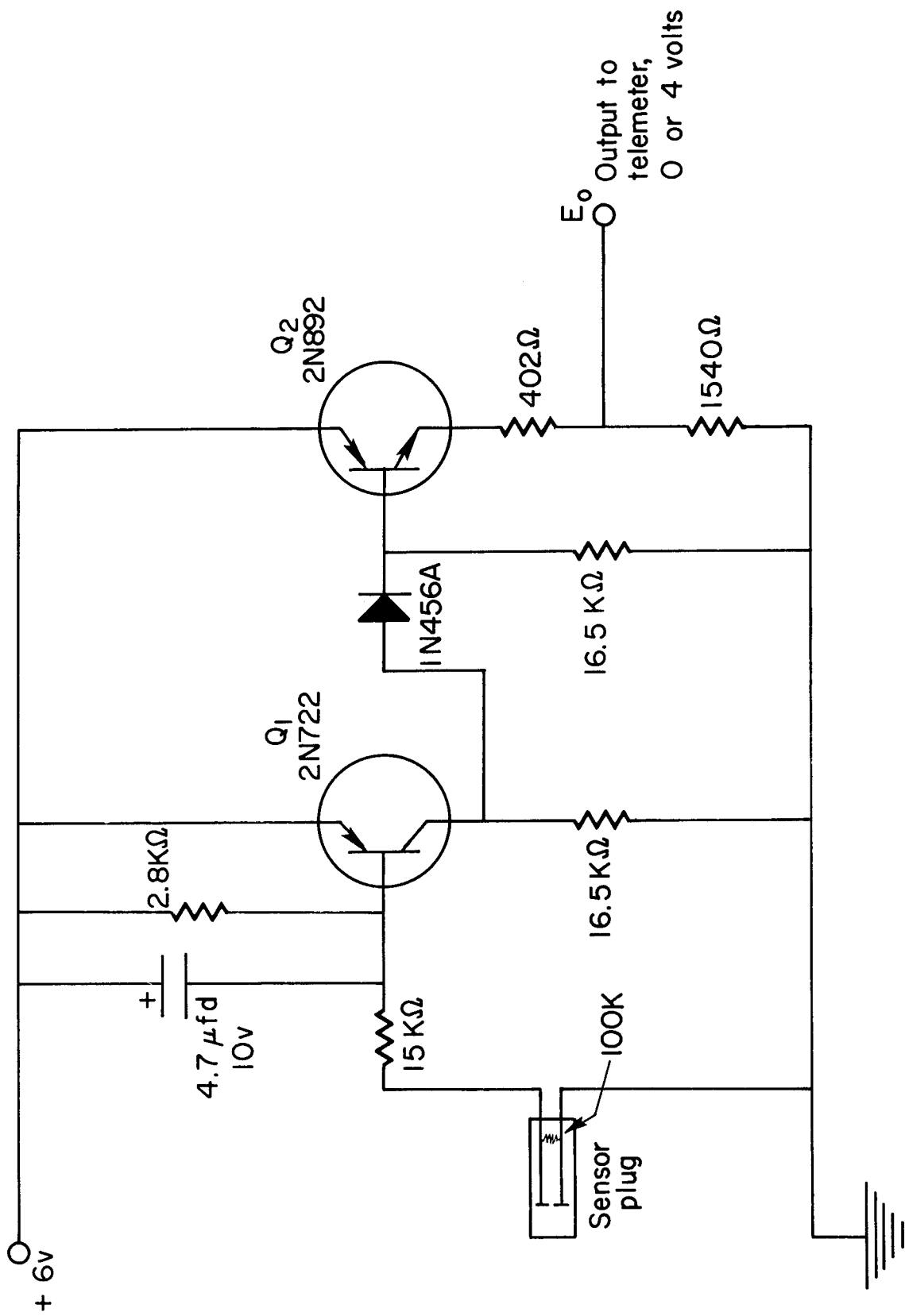

Figure 3.- Make wire ablation sensor signal conditioning circuitry.

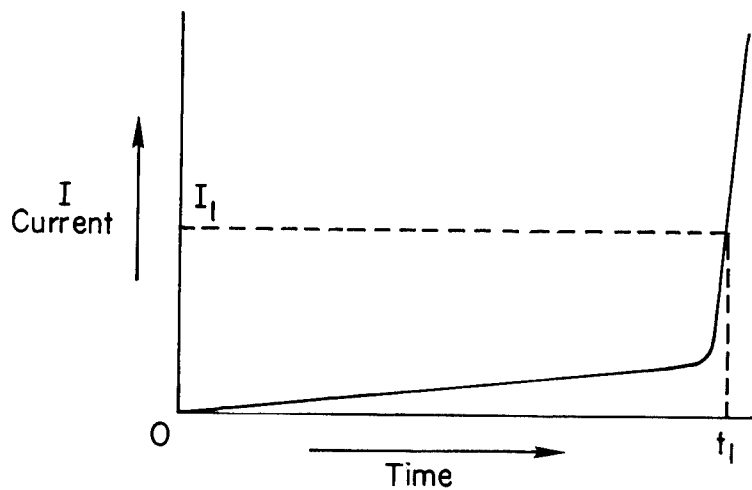
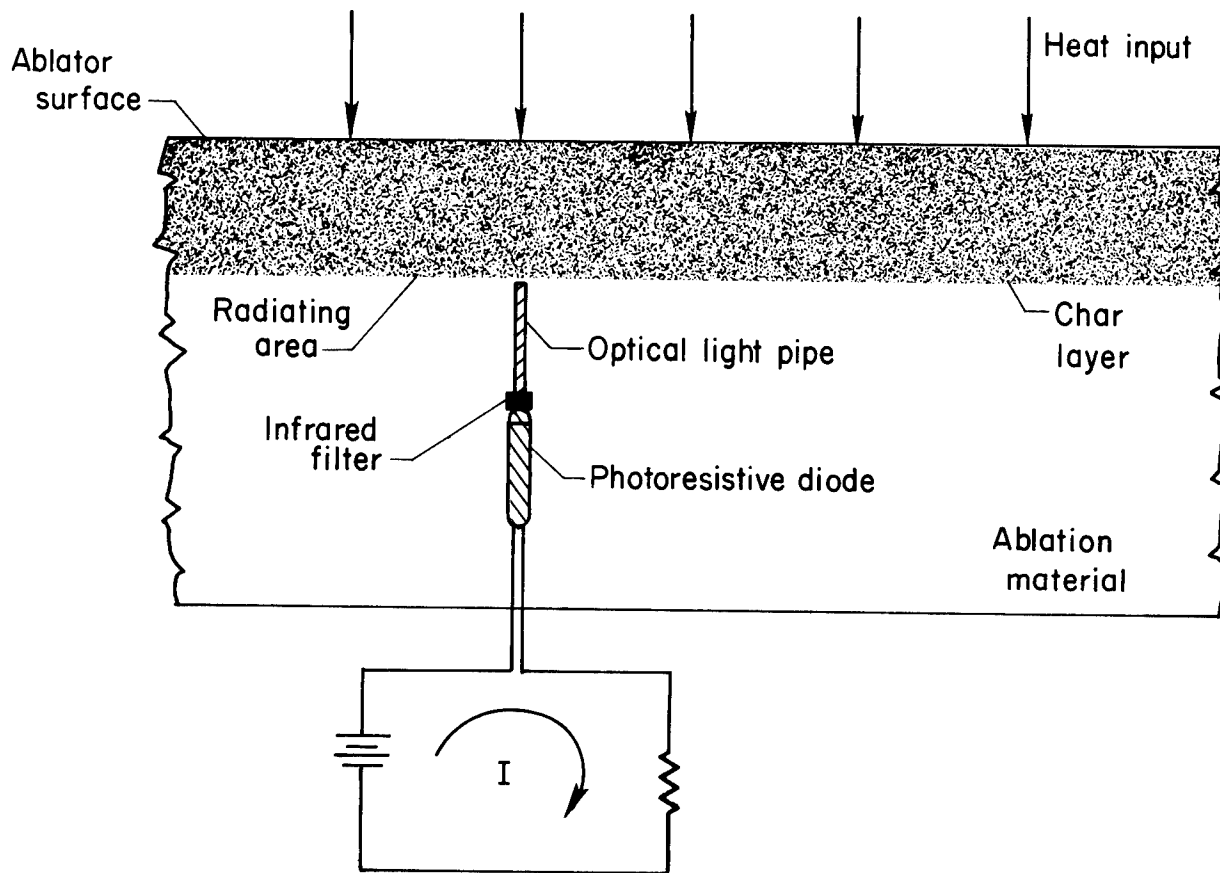

Figure 4.- Mode of operation, light pipe ablation sensor.

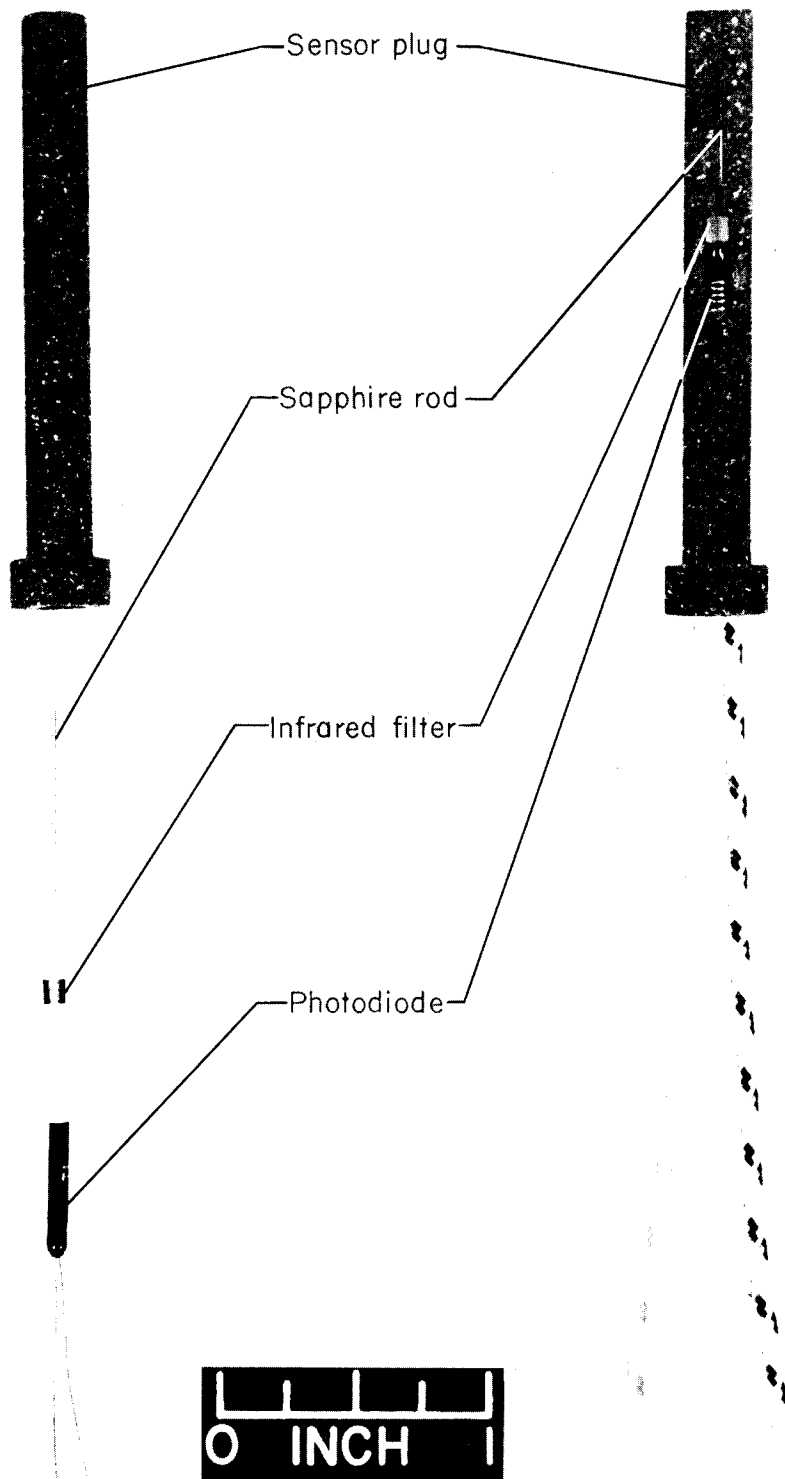

Figure 5.- Light pipe sensor assembly.

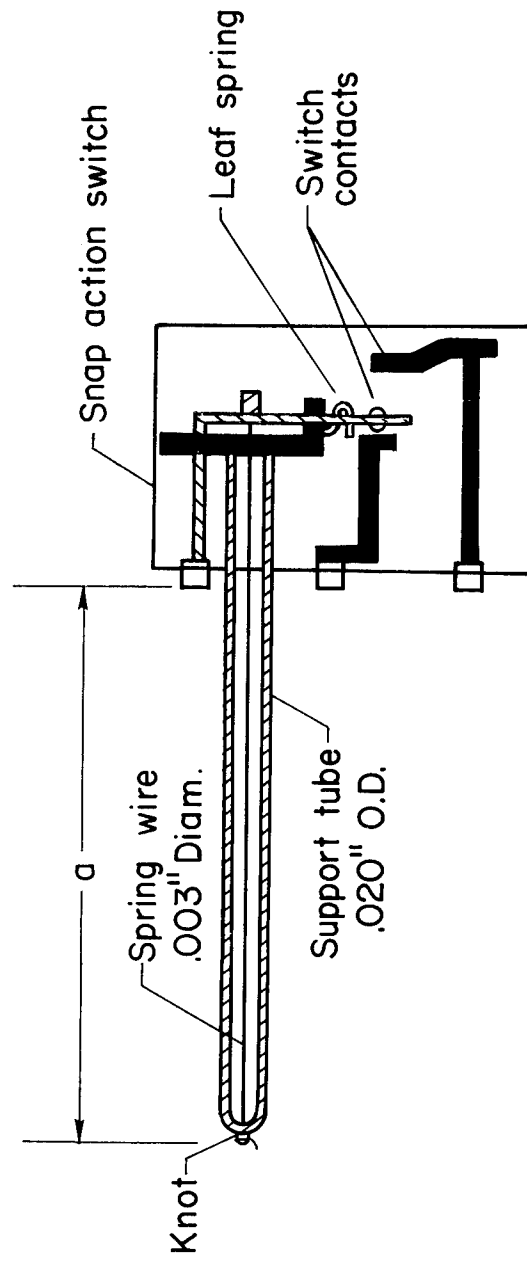

Figure 6.- Spring wire sensor assembly schematic diagram.

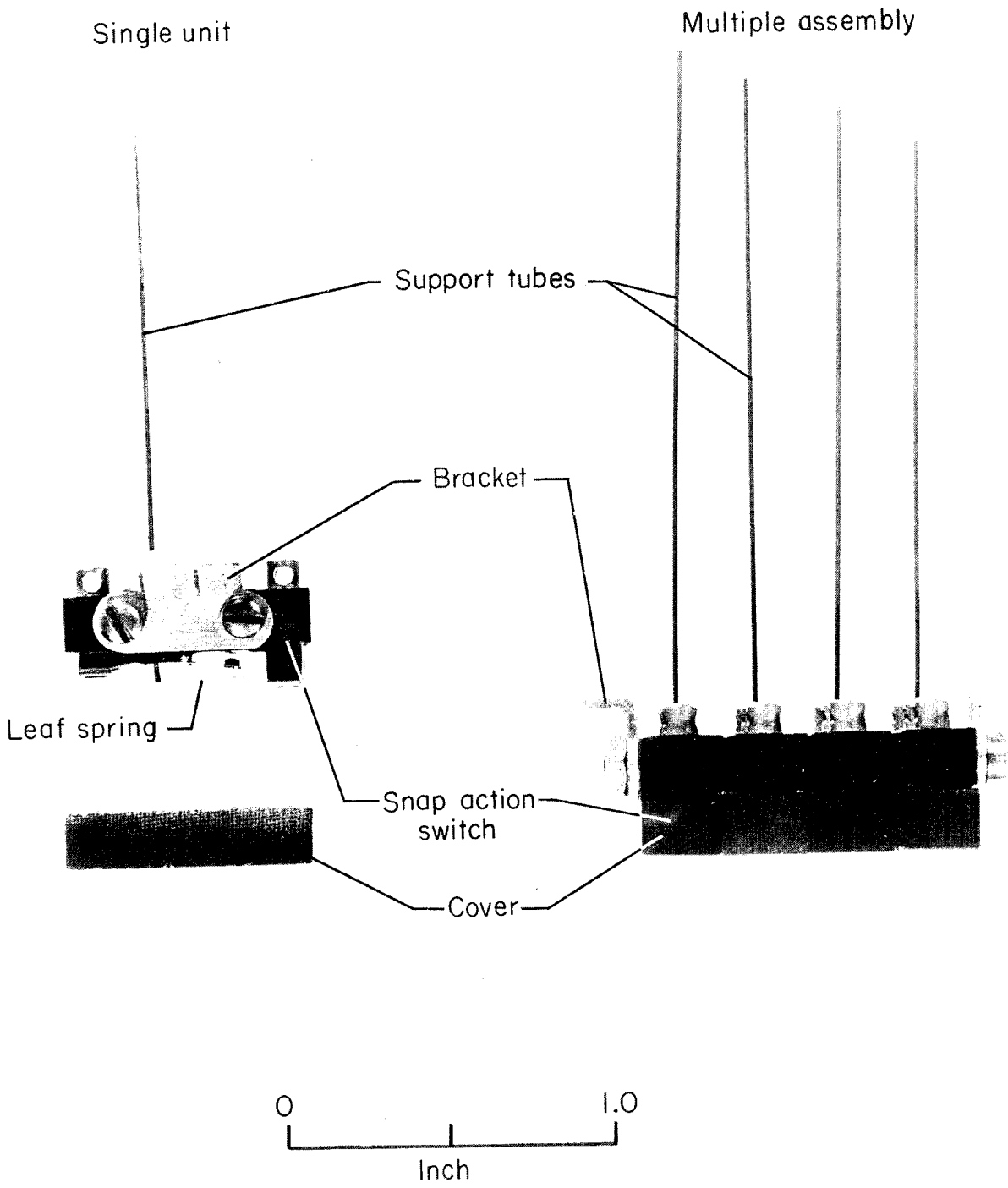

Figure 7.- Spring wire sensor assembly.

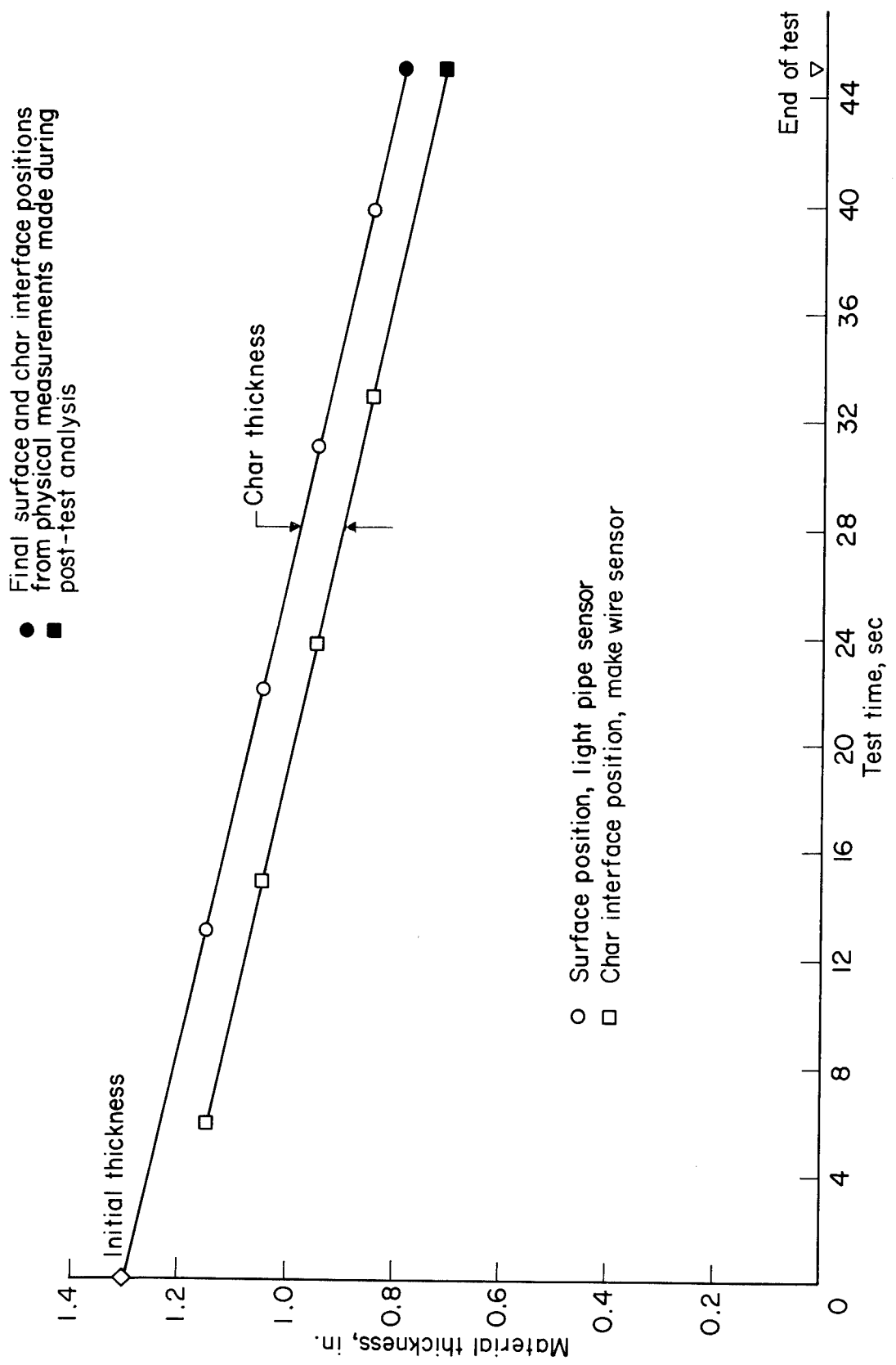

Figure 8.- Arc-jet test results of make wire and light pipe sensors using Apollo type ablator.

● Final surface positions from physical measurements made during post-test analysis
▲

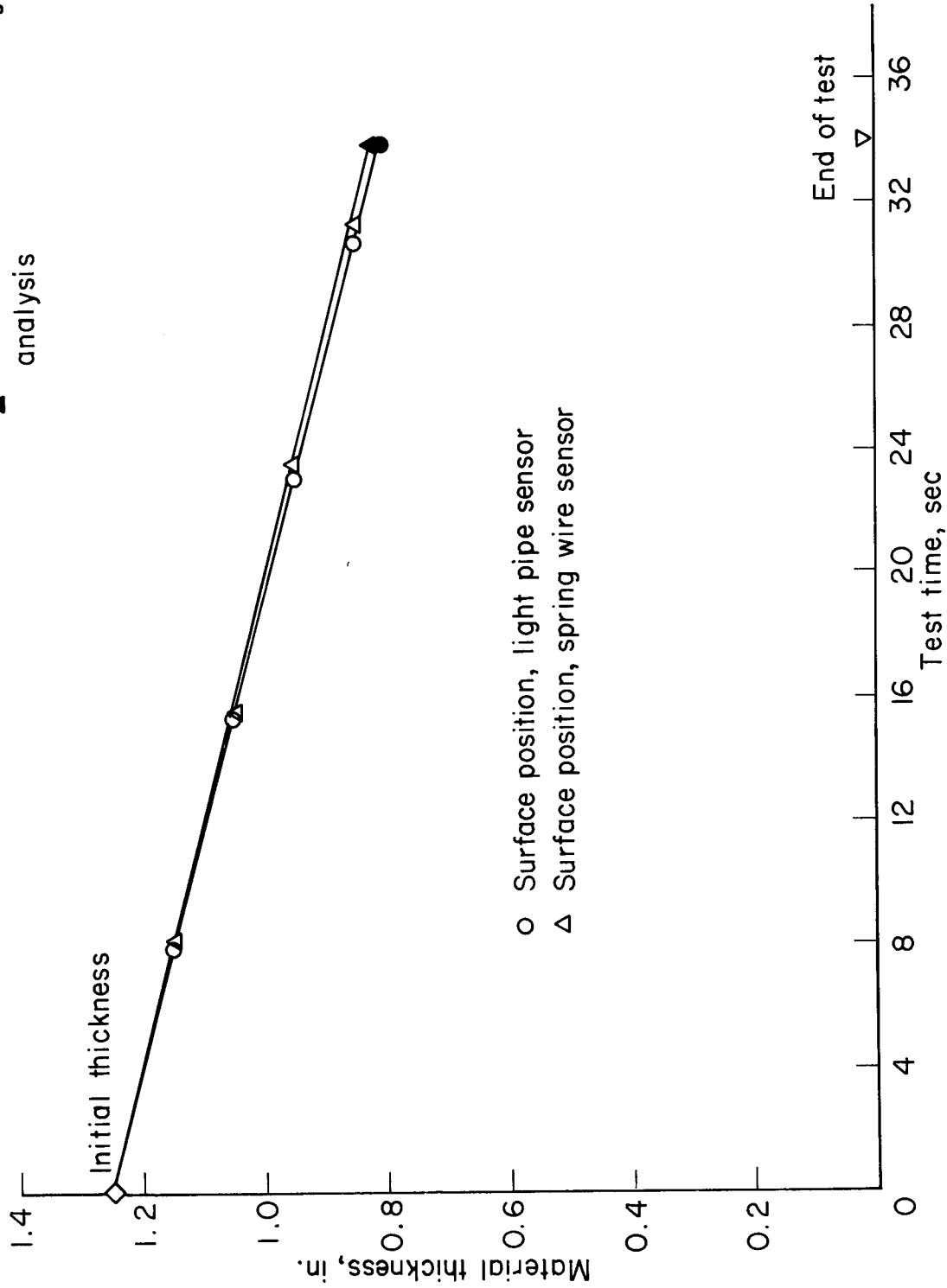

Figure 9.- Arc-jet test results of light pipe and spring wire sensors using Apollo type ablator.