

ame
2/5/92

ADD444197

AD # 87
PLASTECH # 15

DEPARTMENT OF DEFENSE
PLASTICS TECHNICAL EVALUATION CENTER
PICATINNY ARSENAL, DOVER, N. J.



Technical Series

19960424 047

ATC Report No. ARTC-8

TENTATIVE REQUIREMENTS FOR TRANSPARENT
PLASTIC ENCLOSURE MATERIALS

1 June 1954

RESTRICTION BY AIRCRAFT I.A.
Approved for public release
Distribution Unlimited

*Aircraft Industries Association,
610 Shoreham Bldg.,
Washington 5, D. C.*

UNCLASSIFIED/UNLIMITED

DTIC QUALITY INSPECTED 1

4B
PLASTECH
0015

DISCLAIMER NOTICE



THIS DOCUMENT IS BEST QUALITY AVAILABLE. THE COPY FURNISHED TO DTIC CONTAINED A SIGNIFICANT NUMBER OF PAGES WHICH DO NOT REPRODUCE LEGIBLY.

ADD 444197

(12) ~~24~~
79

Aircraft Technical Committee Report No. [ARTC-8,] Rept #
date

(6)

TENTATIVE REQUIREMENTS FOR TRANSPARENT
PLASTIC ENCLOSURE MATERIALS

Title

1 June 1954

(10) - ?

Prepared by the [Aircraft Research and Testing Committee,
Aircraft Industries Association of America, Inc., ^{then} date

new name & address: Aerospace Industries Association of America
1725 DeSales St., N.W.
Washington, DC 20036
(202) 347-2315

TABLE OF CONTENTS

Part I - INTRODUCTION

	Page
Forward	i
Purpose	iii
Part II - ARTC-W-38 TENTATIVE REQUIREMENTS FOR TRANSPARENT MATERIALS	
Plastic Enclosure Materials	1-24
Part III - APPENDIX-SCREENING TEST RESULTS	
General Notes	25
Heat of Distortion	26-27
Tensile Strength - Ultimate, Plain and Notched	28
Tensile Elongation	29
Tensile Modulus, Plain and Notched	29
Barcol Hardness	29
Work to Break, Plain and Notched	30-31
Ultimate Tensile vs Temperature	32
Stress-Strain Curves	33-37
Flexural Strength, Plain and Notched	38-39
Flexural Modulus, Plain and Notched	40
Impact Strength, Plain and Notched	41
Creep Curves	42-43
Weathering Under Tensile Load	44-45
Weathering Under Flexural Load	46
Long Time Flexural Tests, Plain and Notched - Data	47-57
Long Time Flexural Tests, Plain and Notched - Curves	58-68
Craze Resistance	69-71
Forming - Results	72
Cementing - Results	73-74

INTRODUCTION

FOREWARD

With the advent of higher performance aircraft designs there has been a definite requirement for transparent materials for aircraft glazing use with improved properties over those existant in materials available during World War II.

With the above problem in mind the AIA - ARTC sought to affect some improvement in transparent materials for use as canopies, windows and domes made of transparent plastic materials of both the monolithic and laminated type and for pressurized and non-pressurized applications. The W-38 subcommittee was subsequently established for that purpose.

The initial objectives of the W-38 subcommittee were as follows:

- a. Assemble and issue all available test information on present transparent monolithic materials.
- b. Establish and issue a list of aircraft industry requirements for improved transparent materials.

On August 9, 1950 the subcommittee completed and released an AIA document entitled "The Summary of the Properties of Transparent Plastic Aircraft Enclosure Materials." This information was released to the services, the material suppliers and the aircraft industry. It was a compilation of data submitted by the services, the material suppliers and the industries own data.

On September 12, 1950, the "Tentative Requirements for Transparent Plastic Enclosure Materials" was released. This constituted the best list of needed requirements for monolithic materials that could be established by

the industry and was released as such to the services and material suppliers. This list also provided specific test methods for the evaluation of materials.

The new materials being made available prompted the ARTC to initiate a cooperative test program to evaluate these materials in accordance with certain of the tests specified in the list of requirements.

PURPOSE

(29)

This ~~particular~~ report presents the test requirements for transparent materials ^{for aircraft glazing use} and includes a summary of the industry's cooperative testing on a group of these materials. The materials tested included: Plex IA, Plex II, 5014XP, 5015XP, Sierracin 611, Polymer K, and HE 5621.

21

Tables of test data (~~evidently~~ ^{probably} now obsolete) are included.

AUTITOR, MODIFIED

REVISED TENTATIVE REQUIREMENTS FOR
TRANSPARENT PLASTIC ENCLOSURE MATERIALS

- NOTE: (a) Following are the tentative requirements for transparent plastic enclosure materials as revised by the W-38 Subcommittee of the Aircraft Research & Testing Committee at meetings up to and including the one held May 13, 1952.
- (b) All specimens shall be annealed for 16 hours at 25°F below their average heat distortion temperature and cooled at a rate not to exceed 50°F per hour. Following annealing and immediately prior to test, all specimens shall be conditioned for 96 hours at 77 ± 2°F and 50 ± 5% R. H.

MONOLITHIC MATERIAL

- A. Optical Properties - The material shall have optical properties equal to or better than MIL-P-6886 acrylic. **
- B. Heat Distortion Point - Material shall have a heat distortion point of 230°F when tested per ASTM D648-45T at 264 psi. Temperature rise shall be 2°C per minute. (This satisfies present requirements but a heat distortion point of 250°F will be needed in the near future.)
- C. Craze Resistance - The material shall have no tendency to craze or deteriorate under fiber stress of at least 4500* psi with or without solvent action when tested in accordance with MIL-P-6997 except (1) a nominal .125 inch fulcrum radius shall be used, (2) the load shall be applied for ten minutes before addition of solvents, and (3) no crazing during the first five minutes of solvent application shall be apparent.

The solvents to be applied continuously shall be isopropyl alcohol and toluene per Specification TT-T-548. Crazing tests shall also be conducted in the same manner at 2000, 3000, 4000 and 5000 psi and the stress recorded at which crazing first appears.

- D. Tensile Strength - The material must have a tensile strength equal to or better than acrylic base plastics per MIL-P-6886.** Tests shall be conducted per ASTM-D638-49T except wider modifications in the configuration and preparation of Type I specimens are to be allowed. These modifications are to be reported. The ultimate tensile strength after 2 hours at 230°F and tested at 230°F shall not be less than 4000* psi.
- E. Flexural Strength - The material shall have a flexural strength of not less than 16,000* psi when tested per ASTM-D790-45T or L-P-406a. Load deflection curves shall be obtained.
- F. Notch Sensitivity (scratched flexural) -
1. When tested per ASTM-D-790-45T with a scratch on the tensile side, the material shall have a flexural strength of 10,000* psi or not less than 60%* of un-notched ultimate strength at room temperature. Scratch or notch shall be .004 to .007 inches in depth normal to the specimen length in the center of the span extending to within 0.05 inches of either edge as made by a hardened steel scribe .250 inches in diameter, tapered to a point in the distance of one inch, point radius not to be more than .002 inches. Load deflection data shall be reported.
 2. The flexural strength at -65°F shall not be less than the room temperature strength. The specimen shall be conditioned for 24 hours at -65°F and tested at -65°F. Load deflection data shall be reported.

3. The notched flexural strength at 120°F shall be determined and reported.

G. Impact Test - Tests shall be in accordance with ASTM-D-256-41T with the following exceptions:

1. The cantilever beam (Izod type) test shall be used. Weight of the pendulum, scale graduations and construction shall be such as to provide a total range of at least 2 ft. lbs. readable to an accuracy of .02 ft. lbs.
2. The specimen shall be made from sheet stock of .250 nominal thickness and shall be $.250 \pm .010$ thick by $.500 \pm .000$ wide by $2.50 \pm .100$ long. At least one surface shall be left in the as-manufactured condition. Machined surfaces within the central inch of the specimen length shall be smooth-finished with 400 grit abrasive or finer. No polishing is permitted on the as-manufactured surface. The specimen must not be overheated in preparation.
3. The specimen shall be mounted flatwise in the clamps of the impact machine so that the pendulum strikes across the thickness dimension causing tension in the as-manufactured surface.
4. Notched specimens shall be prepared by placing the scratch in the tension (as manufactured) surface at the centerline of the specimen and extending across the .500 inch dimension to within .05 inches of either edge. The scratch shall be $.004 - .007$ deep, made with a hardened steel scribe .250 inches in diameter tapered to a point in the distance of 1 inch, point radius not to exceed .002 inches. The notched specimen shall be mounted so that the distance from the scratch to the level of the top of the clamping surface is $.000 - .010$ inches.

5. Tests shall be conducted at room temperature and at -65°F .
6. Test Values - Impact test values averaged from a group of five, shall not be less than indicated below. Individual test values shall not deviate more than 20% from the average. Desired values are the same for room temperature and for -65°F .

Plain Specimen	1.5 ft./lbs.	* per inch of width
Notched Specimen	.5	*

H. Elevated Temperature Creep Tests - When subjected to four of the temperature-stress cycles described under paragraphs 1 through 8 below, .25 inch thick tensile test specimens, prepared as per Specification LP-406a Method 1011 (Type I Specimens), shall not exhibit more than 3 per cent* permanent extension between gage marks. Cycle specimens as follows:

1. Place test specimens in a circulating air oven at $230 \pm 3^{\circ}\text{F}$ for one hour at zero load.
2. Maintaining the test specimen at $230 \pm 3^{\circ}\text{F}$ apply a tensile stress of 600 psi for one hour.
3. Remove the tensile stress and allow specimen to remain unloaded at $230 \pm 3^{\circ}\text{F}$ for one hour.
4. Repeat steps 2 and 3 two additional times.
5. Maintaining the test specimen at $230 \pm 3^{\circ}\text{F}$ apply a tensile stress of 600 psi for one hour.
6. After the one hour loading period and while maintaining the test specimen under the 600 psi stress at $230 \pm 3^{\circ}\text{F}$., determine the maximum extension.

7. Unload the specimen and allow it to cool at room temperature and stand unloaded for 16 hours.
 8. Determine the permanent extension at room temperature at zero load after the 16 hour unloaded period.
 9. One temperature-stress cycle consists of steps 1 through 8 inclusive. Extension at load and at no load for each cycle shall be recorded.
- I. 10,000 Hour Flexural Strength Requirements: (Tentative) Material shall have 10,000 hour flexural strength of 3000* psi without crazing or deterioration when determined by the following method:
1. Test shall be conducted per ASTM-D790-45T using .250 material, except the specimen shall have a standard scratch per the short time notched bending test. Test conditions shall be $50 \pm 5\%$ R.H. and $75 \pm 5^\circ\text{F}$ temperature. Three specimens shall be loaded to 50% ultimate stress determined from the short time notched bending test, three loaded at 60%* ultimate and three at 80%* ultimate. Record the initial deflection of each specimen and the creep each 24 hours. Also record the time of failure in hours.
 2. Plot the results on log-log graph paper with the ordinates representing hours and the abscissae maximum fiber stress in bending as calculated by the simple beam formula. Place a point for the short time ultimate stress on the ordinate representing 0.1 hour, and place points for the time of failure in hours of 50, 60 and 80% ultimate stress specimens on their proper ordinates. Draw a straight line between the short time ultimate stress point and the center of the group of points obtained from loads less

than ultimate. Extend this line to the ordinate 10,000 hours and record the stress allowable at that point. This stress shall be considered the 10,000 hour flexural strength.

J. Weathering Tests

Test arrangement and conditions shall be in accordance with ASTM-D674-42T with the following exceptions:

1. Minor modifications are permitted in the shape of the specimen to insure proper gripping and uniform loading within the test length. Suitable specimens and grips are shown in attached figures 1 and 2 (pages 14 and 15). Deviations from these specifications are to be reported.
2. The specimen shall be made of standard sheet product, and the as-manufactured surfaces shall be free of scratches and not disturbed during fabrication of the specimen.
3. Materials need not be classified into groups of materials. Extensometers and deformation measurements are not required. Gage marks shall not be made on the specimen.
4. Duplicate specimens shall be tested at constant stresses of 1. 2000 psi, 2. 4000 psi and 3. 6000 psi.
5. The test shall be conducted under exposure condition, in a region where incident sunlight under clear sky conditions would be unobstructed for at least 60%* of the daylight hours. Protection from ground winds and artificial disturbances is desired.
6. Observations shall be made and reported of the nature and time required for any kind of deterioration, and the total time until fracture occurs.

7. Simultaneous tests shall be conducted on the unknown material and on MIL-P-6886 acrylic material to establish a basis for comparison. Requirements are as follows:

The average "life-time" under 4000 psi shall be in excess of the average time for fracture of MIL-P-6886 acrylic at 4000 psi.

The average "life-time" under 6000 psi shall be in excess of the average time for fracture of MIL-P-6886 acrylic at 4000 psi.

"Life-time" is defined as the time required to produce any objectionable discoloration, deterioration, or crazing discernible under the most critical lighting conditions, within the test length.

- K. Forming - Material shall be capable of being formed to a spherical segment as follows: 1/4 thick sheet, 1 ft. in diameter shall be capable of being drawn to a depth of 3 inches for canopies and 6 inches for domes.

In conducting the forming tests fixed clamping shall be used and no slippage shall occur. Depth of draw at forming pressures of 3, 6, 9, 12, psi and higher pressures if necessary and forming procedure and temperatures shall be reported. Exceptions to the above requirements will be allowed for those applications which do not require high temperature performance, high degree of forming, etc.

- L. Hardness - The material at room temperature shall have a minimum hardness value of 35 when determined by the Barcol impressor.

- M. Joining - The material shall be capable of being joined by conventional cementing procedures and a minimum bond strength of 3500* psi shall be required when tested in accordance with the test for Bond Strength of Monolithic Transparent Enclosure Materials (Enclosure D, Minutes of June 11 and 12, 1951, Meeting, ARTC-WR-51-87 July 17, 1951). Test is outlined on pages 16 through 24.
- N. Flammability - It is desirable that the burning rate does not exceed that of MIL-P-6886** acrylic.
- O. Water Absorption - The water absorption shall not exceed that of MIL-P-6886** acrylic.
- P. Coefficient of Thermal Expansion - The coefficient of thermal expansion shall not be greater than, and it is desirable that it be less than MIL-P-6886** acrylic.

LAMINATED MATERIAL

- Note: (a) All tests shall be conducted on a standard laminate having .150 faces and .20 interlayer, and tensile values shall be based on the face sheet area only.
- (b) Heat stability tests shall be performed on all material prior to test.

A. Heat Stability and Forming

1. Heat Stability:

- 1.1 Requirements: After heating for one half hour, as described in paragraph 1.2 below, the laminated sheet shall conform to the physical property requirements defined in this specification.

- 1.2 Test Procedure:
- 1.2.1 A test specimen of the laminated sheet, minimum four square inches, shall be hung vertically in a circulating air oven stabilized at temperature referred to in paragraph A-2 below.
- 1.2.2 After heating one half hour, the test specimen shall be removed from the oven, cooled at room temperature at a rate not to exceed 50°F per hour.
2. Forming Temperature Range: The manufacturer shall define the processes and forming temperature range to be used in forming parts. The forming temperature range is defined as the difference between the maximum and minimum temperatures that may be used in the forming process without deleteriously affecting the laminated sheet. The forming temperature range shall not be less than 20°F.
3. Forming Requirements: This requirement covers three different grades of laminated sheet with respect to forming properties (i.e., sheet usable for forming (1) Shallow Drawn Shapes, (2) Deep Drawn Shapes, and (3) Single Curvature Shapes).
- 3.1 Shallow Drawn Shapes (Canopies)
The laminated sheet shall be capable of being drawn to a depth of 2 inches when formed through a 14 inch diameter ring. The sheet shall also be capable of being formed into a single curvature shape with a radius of 7 inches.
- 3.2 Deep Drawn Shapes (Domes): The laminated sheet shall be capable of being formed into a hemisphere with a radius of 7 inches.

3.3 Single Curvature Shapes (Windows): The laminated sheet shall be capable of being formed into a single curvature shape with a radius of 20".

B. Optics

1. Original Haze - The haze in the as-received condition shall be no greater than 4.0% when measured in accordance with the test for Visible Light Transmission and Haze, Method 3021, of Specification L-P-406a.
2. Minor Optical Defects - The total number of minor defects shall not exceed three per four square feet and all minor defects shall be at least six inches apart. Minor defects include any imbedded particles, sleeks, orange peel, bubbles, or scratches which reduce visibility through the plastic. Blemishes which do not individually reduce visibility through the plastic shall be disregarded. Defects within one inch of the edge of the sheet shall be disregarded. Inclusions such as lint, hair, and dust particles shall not be considered blemishes unless they individually affect an area greater than that equal to the area of a circle with a diameter of 0.20 inches. Splices in the interlayer will be allowed.
3. Angular Deviation - The material shall contain no variations which cause an angular deviation of more than 8 minutes either side of the undeviated position. The movement of the image shall not be irregular or wavy. The angular deviation shall be determined in accordance with the test method for Optical Uniformity, Method 3041 of Specification L-P-406a.

4. Optical Distortion - The optical distortion value of the material shall be no less than 12 inches excluding a margin of two inches when tested in accordance with Optical Uniformity, Method 3041 of Specimen L-P-406a.

C. Fracture Resistance at Low Temperature - A specimen approximately eight square inches in area shall be cooled to $-18^{\circ} \pm 2^{\circ}\text{C}$ ($0 \pm 4^{\circ}\text{F}$) for sufficient time to insure equilibrium temperature throughout the laminate. The specimen shall be placed on a rigid flat surface with the geometric center of the specimen over a 1/2 inch diameter hole in the flat surface and immediately struck near the geometric center with a one pound ball dropped from a height of 8 feet. If both layers of the face sheet are not fractured, the specimen shall be turned over and struck again with the same force.

After fracture at low temperature in accordance with the above test, the test specimen shall show no delamination from any crack in the face sheet material.

D. Long Time Tensile Test

Test arrangement and conditions shall be in accordance with ASTM D674-48, with the following exceptions:

1. Minor modification is permitted in the shape of the specimen to insure proper gripping and uniform loading within the test length. Suitable specimen and grip configuration Fig. I and II respectively (pages 14 and 15). Deviations from these specifications are to be reported.

2. The specimen shall be made from standard sheet product. The as-manufactured surfaces shall be kept free of scratches and undisturbed during the fabrication of the specimen.
3. Machining of the specimen shall be accomplished with cutters and speeds which introduce no local heating or surface effects into the specimen. Generally recommended is a small diameter router cutter turning at high speed, but traversing slowly; best combination of speeds and cutter face angles should be determined for the particular test material. If necessary, specimens should be finished with 400 sandpaper and polished. Polariscopic examination can sometimes be used to check for strains by the machining operations.
4. Machined edges of the specimen which remain exposed after installation in the test grips shall be coated with EC 226 cement (Minnesota Mining & Manufacturing Company) and allowed to dry for 24 hours before loading.
5. Measurement of elongation is not required. No gage marks shall be made on the specimen.
6. Specimens shall be tested at constant stresses of 1,000, 2,000, 4,000 and/or 6,000 psi.
7. The tests shall be conducted under outside exposure conditions in an area where incident sunlight under a clear sky would be unobstructed for at least 60% of the daylight hours. Protection from ground winds and artificial disturbances is desired.
8. Observations shall be made to determine the time for crazing to be initiated, the time to failure, and any unusual behavior during the test.

FIG. II

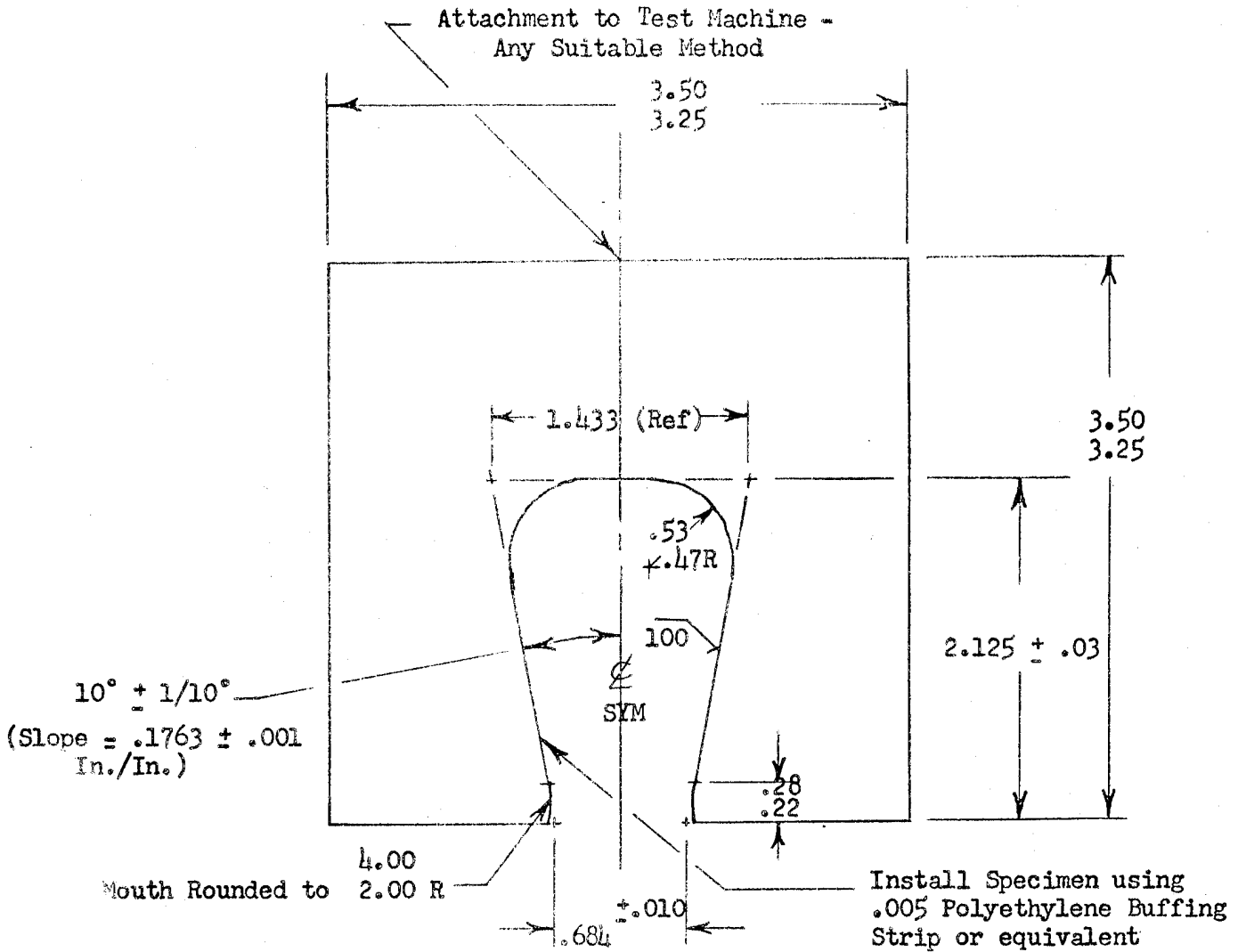

Material: 3/4 thick 24ST aluminum alloy plate or equivalent
Anodize

GRIP - PLASTIC

Scratches Not Permissible
 Thickness: As Received

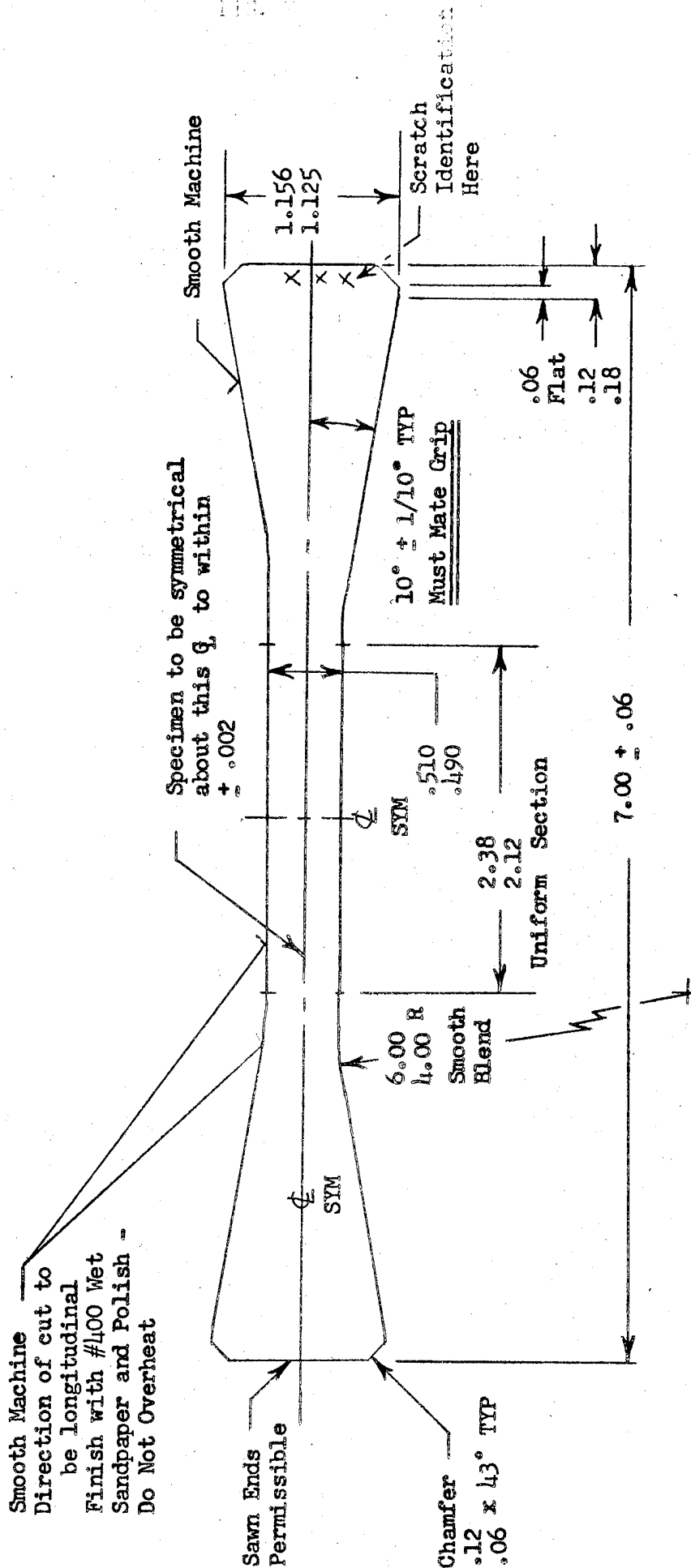

PLASTIC TENSILE COUPON

TENTATIVE SPECIFICATION FOR TESTING BOND STRENGTH OF TRANSPARENT PLASTIC

ENCLOSURE MATERIALS

1. Scope

1.1 This specification describes a test procedure for determining the bond strength, based on compression shear, of monolithic transparent plastic enclosure materials.

2. Test Specimen

2.1 The nominal specimen configuration shall be as shown in Figure 1.

3. Apparatus

3.1 The test jig used shall be as shown in Figures 2, to 7 (pages 18 to 24).

3.2 All tests shall be conducted on a standard universal testing machine of suitable capacity.

4. Procedure

4.1 Preparation of control specimens

4.1.1 When required, five control specimens shall be made to conform to Figure 1, and shall be made of Plexiglas II, Specification MIL-P-5425.

4.1.2 Soak cemented joints shall be prepared from 0.250 Plexiglas II strips milled to one inch widths. Except for the areas to be jointed, the strips shall be masked with cellophane tape. One joint half shall be soaked for 17 minutes in acrylic monomer base cement, Specification No. AN-C-144 (catalyzed with 0.4 grams per pound of crystalline

benzoyl peroxide) and placed into position over the remaining joint half. The two joint halves shall be held together with a pressure of approximately 5 psi for a minimum of 24 hours. Following this the joints are to be heat cured for 24 hours at $120 \pm 5^{\circ}\text{F}$ before being sawed and milled to the configuration shown in Figure 1.

4.2 Preparation of Test Specimens

4.2.1 Five test specimens shall be prepared from 1 inch milled strips of the material under consideration, and shall conform to Figure 1.

4.2.2 When applicable, specimens shall be prepared in a manner similar to the control specimens Par. 4.1.2. For other materials joints shall be made with suitable cements and in accordance with the manufacturer's instructions.

4.3 Testing of Specimens

4.3.1 Specimens shall be accurately measured and then tested by using the test jig shown in Figure 2. The specimens shall be placed in the jig, and the testing machine started. The head travel shall be adjusted to $0.05 \pm 25\%$ inches per minutes, and shall be maintained until the specimen ruptures.

5. Test Data

5.1 The test report shall include the following data:

5.1.1 Type of material and manufacturer's designation.

5.1.2 The cement and procedure used for bonding the material.

5.1.3 The results of the five control specimens and the average result expressed in pounds per square inches of shear.

5.1.4 The results of the five specimens under consideration and the average result expressed in pounds per square inch of shear.

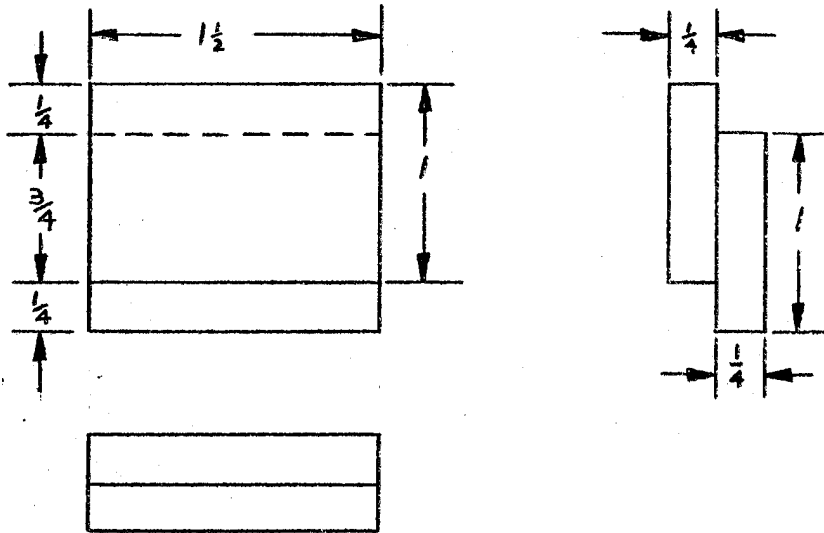

TOLERANCE $+0 -\frac{1}{32}$

FIGURE 1
 SPECIMEN
 CONFIGURATION
 SCALE - FULL SIZE

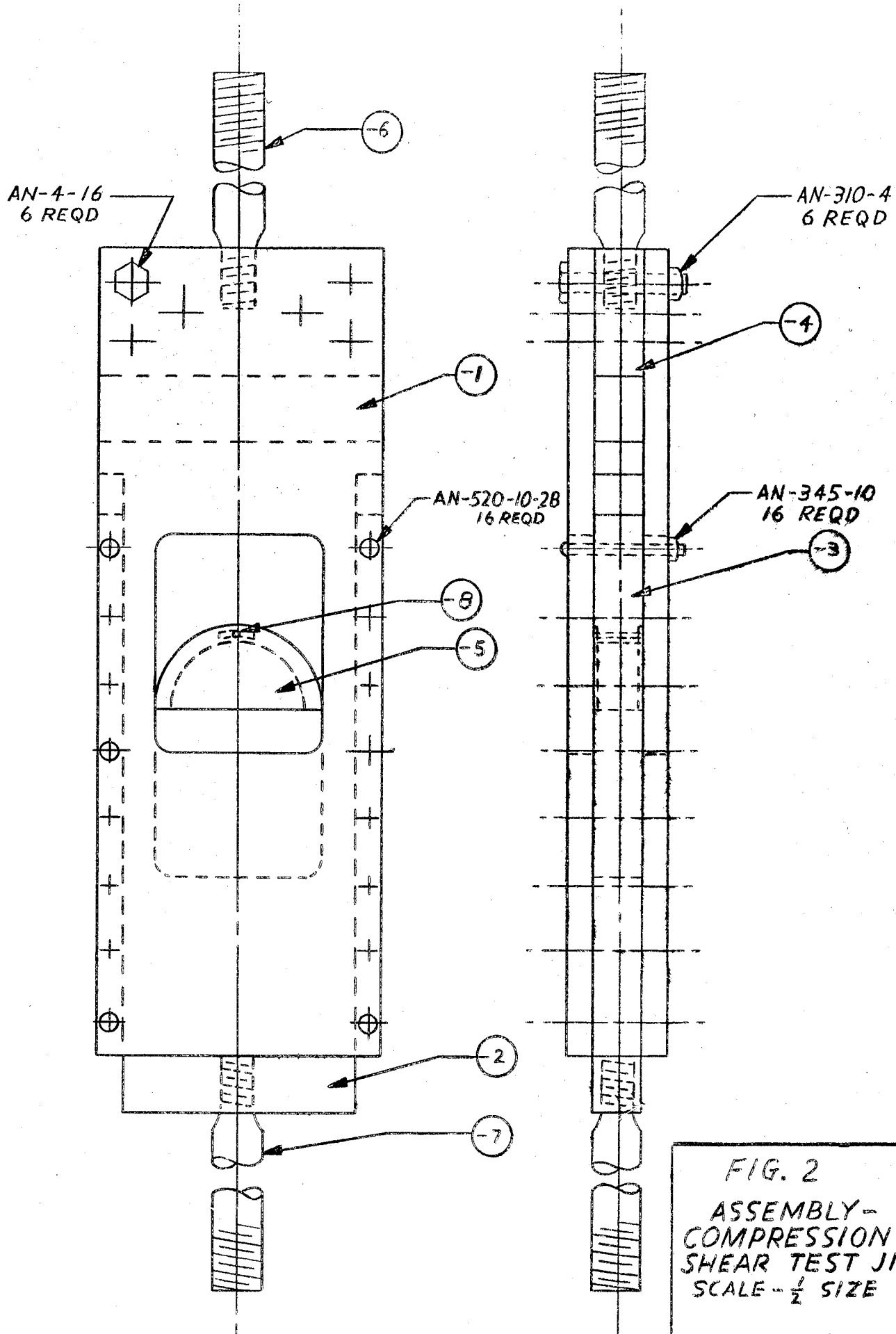

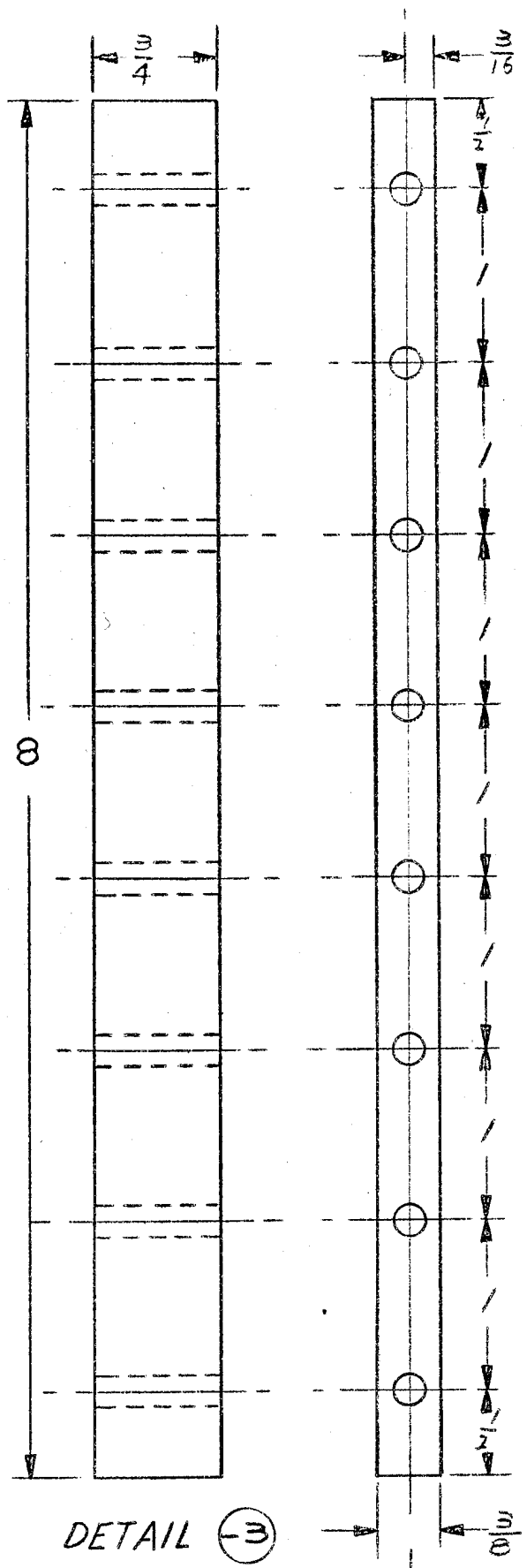

NOTES: 1. MATERIAL-
COLD ROLLED STEEL
2. TWO PIECES REQD.
3. DRILL HOLES FOR
AN-520-10-28 SCREWS.

FIG. 5
DETAIL -3
COMPRESSION
SHEAR TEST JIG
SCALE - FULL SIZE

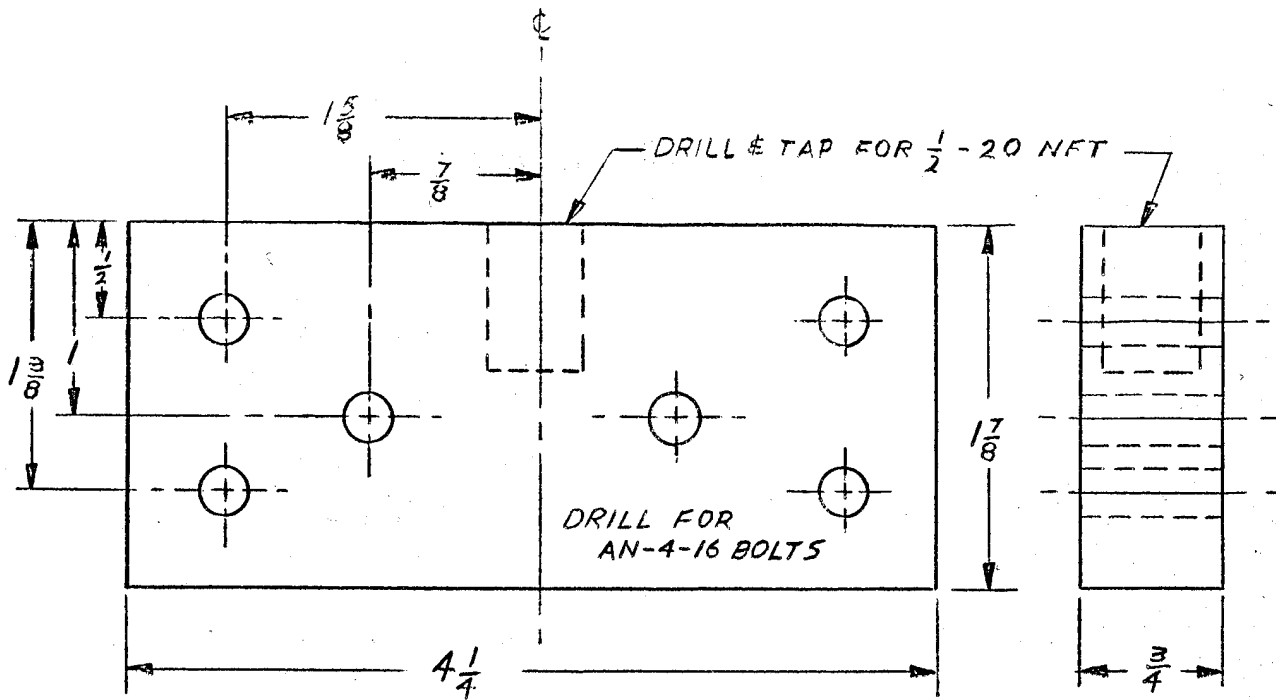

DETAIL (4)

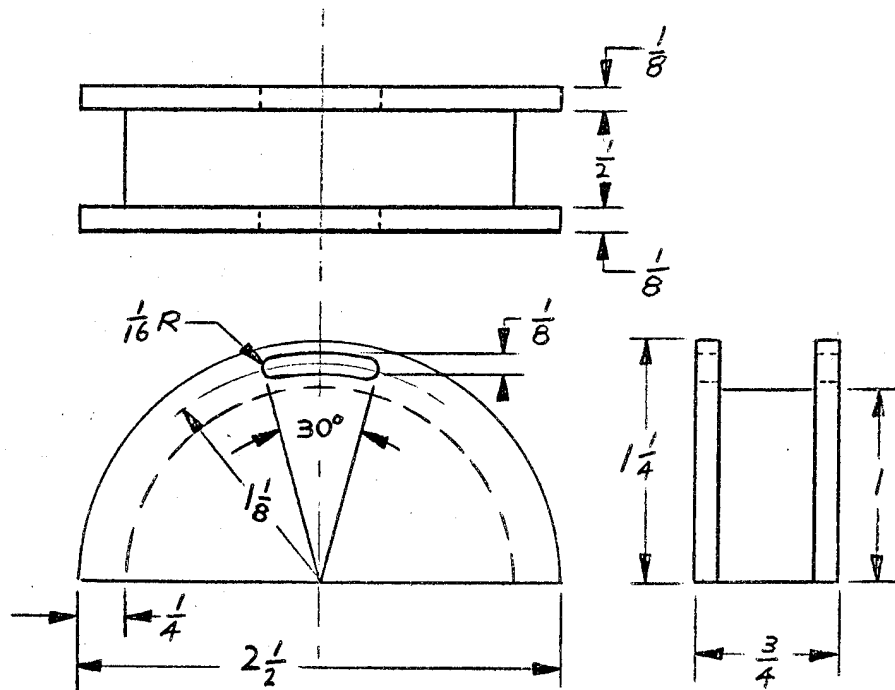

DETAIL (5)

MATERIAL - COLD ROLLED STL.

FIG. 6
 DETAILS 4 & 5
 COMPRESSION
 SHEAR TEST JIG
 SCALE - FULL SIZE

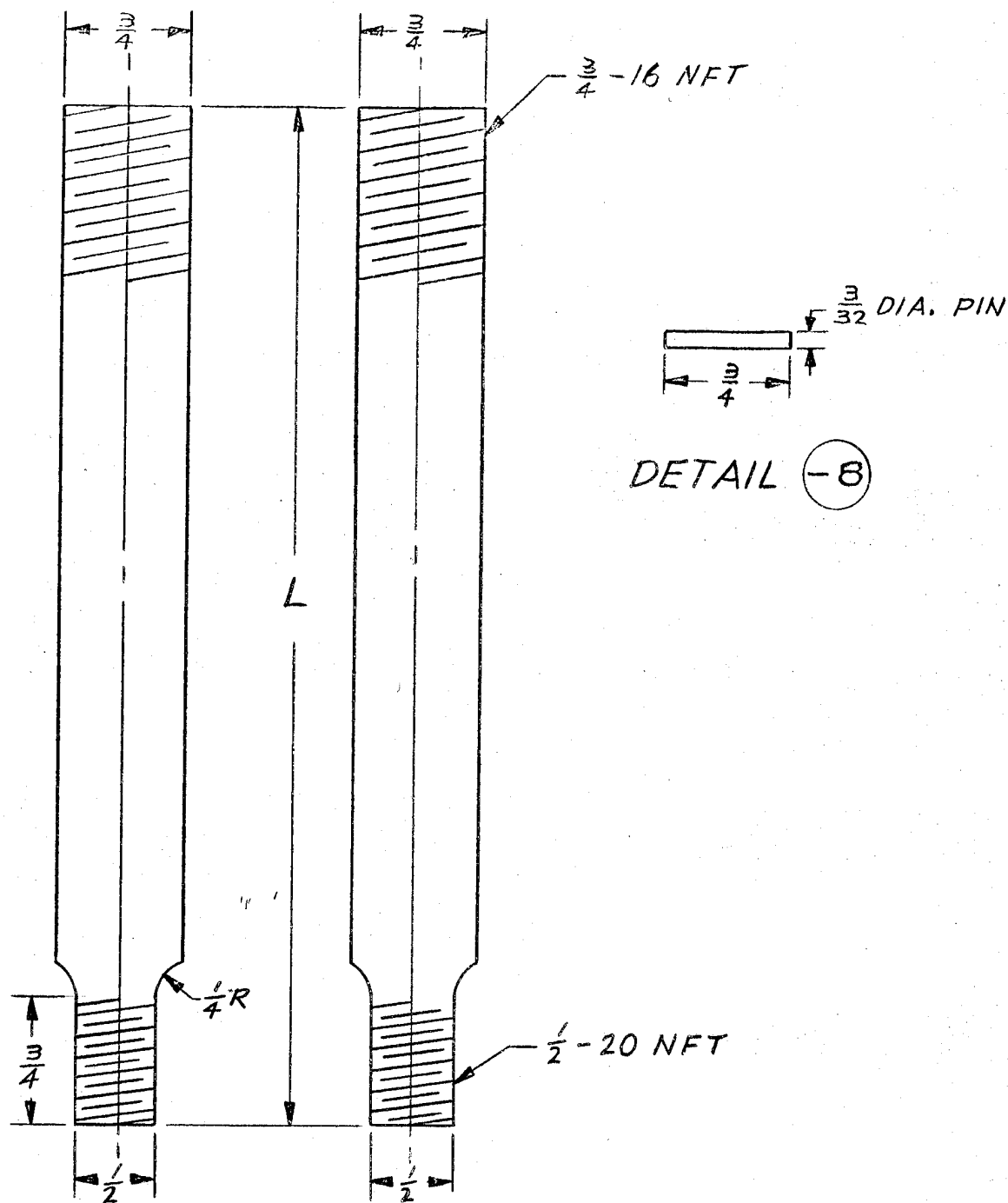

DETAILS (6) & (7)

NOTE: 1. MATERIAL - COLD ROLLED STEEL
 2. DIM. "L" TO FIT TESTING MACHINE

FIG. 7
 DETAILS - 6 - 7 & - 8
 COMPRESSION
 SHEAR TEST JIG
 SCALE - FULL SIZE

GENERAL NOTES ON TEST RESULTS

1. On data sheets the following abbreviations are used in "Source of Data" columns:

B - Boeing Airplane Company

D - Douglas Aircraft Company

L - Lockheed Aircraft Corporation

N. A. - North American Aviation, Inc.

Nor. - Northrop Aircraft, Inc.

2. The 10,000 hour flexural strength values as represented on the long time flexural graphs are not absolute because of the spread of plotted time values at 50, 60, 80 and 100% of ultimate stress, it is possible to vary the slopes of the straight lines thus obtaining different intersections with 10,000 hour ordinates.

HEAT OF DISTORTION

<u>MATERIAL</u>	<u>DATA SOURCE</u>	<u>NUMBER SPECIMENS</u>	<u>RESULTS - °F</u>		
			<u>MAXIMUM</u>	<u>MINIMUM</u>	<u>AVERAGE</u>
Plex IA	L	1	-	-	165
Plex II	L	1	-	-	202
5014XP	N.A.	5	221	208.5	214.5
5105XP	N.A.	5	226.4	221.9	223.3
Sierracin 611	L	4	221	217	219
	N.A.	5 *(1)	183.2	174.2	179.2
	N.A.	5 *(2)	179.6	176.9	177.8
MACA	L	10	189	179	184
	N.A.	5	275	271.4	272.5
Polymer K	N.A.				246
HE5621	N.A.				236

* (1) No annealing - 96 hr. at $77 \pm 2^\circ\text{F}$ and $50 \pm 3\%$ relative humidity.

* (2) Before Machining - 1/2 hr. at $275 \pm 2^\circ\text{F}$.

After Machining - annealed 23.5 hrs. at $155 \pm 3^\circ\text{F}$ followed by 96 hrs. at $77 \pm 2^\circ\text{F}$ and $50 \pm 3\%$ relative humidity.

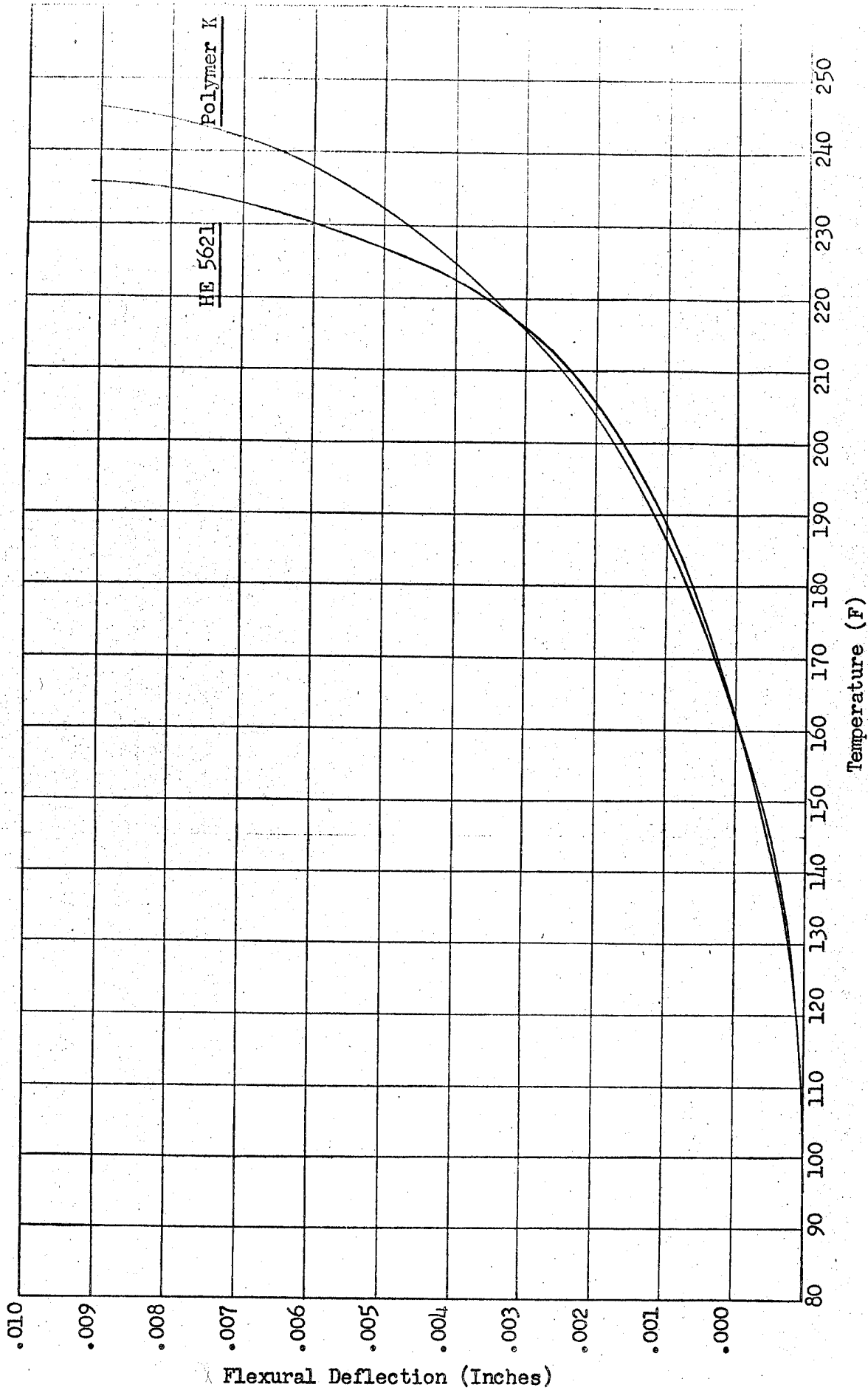

FLEXURAL DEFLECTION VERSUS TEMPERATURE

Source: North American

TENSILE ULTIMATE

MATERIAL	SPECIMEN CONDITION	TEST TEMP. °F	DATA SOURCE	NO. SPEC.	RESULTS - PSI		
					MAXIMUM	MINIMUM	AVERAGE
Plex IA	Plain	R.T.	B	2	8,050	5,160	6,605
Plex II	Plain	R.T.	B	2	8,900	8,770	8,835
	Plain	R.T.	L	9	9,960	8,430	9,580
	Plain	75	D	3	12,100	11,600	11,900
	Plain	160	D	3	8,400	7,500	8,000
	Plain	200	D	3	4,700	3,800	4,200
	Plain	230	D	3	2,800	2,400	2,600
5014XP	Plain	R.T.	B	3	12,270	10,370	11,600
	Notched	R.T.	B	3	8,730	8,200	8,500
5105XP	Plain	R.T.	B	3	11,680	10,340	11,090
	Plain	R.T.	L	2	10,460	10,250	10,355
	Plain	75	D	3	12,200	11,800	11,900
	Plain	160	D	3	8,800	8,300	8,500
	Plain	200	D	3	7,500	6,600	6,900
	Plain	230	B	3	2,600	2,300	2,500
	Notched	R.T.	B	3	9,290	7,970	8,720
Sierracin 611	Plain	R.T.	B	2	10,710	10,140	10,420
	Plain	R.T.	L	15	10,350	8,900	9,600
	Plain	75	D	3	10,300	8,000	8,900
	Plain	160	D	3	6,400	6,000	6,200
	Plain	200	D	3	2,400	2,100	2,200
	Plain	230	D	3	1,800	1,300	1,500
	Notched	R.T.	B	3	6,500	5,960	6,240
General	Plain	R.T.	B	3	17,850	13,870	16,790
Analine	Plain	75	D	3	18,000	17,600	17,900
MACA	Plain	160	D	3	14,400	14,000	14,200
	Plain	200	D	3	11,000	10,600	10,800
	Plain	230	D	3	8,300	8,100	8,200
	Notched	R.T.	B	3	13,320	12,000	12,450
Polymer K	Plain	R.T.	B	3	12,200	11,530	11,980
	Notched	R.T.	B	3	10,700	8,520	9,270
HE5621	Plain	R.T.	B	1	-	-	11,540
	Notched	R.T.	B	3	10,430	10,270	10,330

TENSILE ELONGATION

DATA SOURCE: LOCKHEED

MATERIAL	SPECIMEN CONDITION	TEST TEMP. °F	NUMBER SPECIMENS	RESULTS - %		
				MAXIMUM	MINIMUM	AVERAGE
Plex IA	Plain	R.T.	1	-	-	3.5
Plex II	Plain	R.T.	9	4.8	2.7	4.0
5105XP	Plain	R.T.	2	4.6	4.4	4.5
Sierracin 611	Plain	R.T.	15	3.5	2.5	3.0

TENSILE MODULUS

DATA SOURCE: BOEING

MATERIAL	SPECIMEN CONDITION	TEST TEMP. °F	NUMBER SPECIMENS	RESULTS - PSI X 10 ³		
				MAXIMUM	MINIMUM	AVERAGE
Plex IA	Plain	R.T.	2			350
Plex II	Plain	R.T.	2			421.75
5014XP	Plain	R.T.	3	612	565	587
5105XP	Plain	R.T.	3	541	512	525
Sierracin 611	Plain	R.T.	3	567	550	557
MACA	Plain	R.T.	3	846	826	834
Polymer K	Plain	R.T.	3	476	455	465
	Notched	R.T.	3	481	464	470
HE5621	Plain	R.T.	3	500	485	492
	Notched	R.T.	3	507	507	507

BARCOL HARDNESS

MATERIAL	TEST TEMP. °F	DATA SOURCE	NUMBER SPECIMENS	MAXIMUM	MINIMUM	AVERAGE
Plex II	R.T.	L	9	50	42	46
5105XP	R.T.	L	2	-	-	48
Sierracin 611	R.T.	L	15	46	42	44
MACA	R.T.	D	-	70	60	65

WORK TO BREAK *

DATA SOURCE: BOEING

MATERIAL	SPECIMEN CONDITION	TEST TEMP. °F	NUMBER SPECIMENS	RESULTS - IN. LBS./IN. WIDTH		
				MAXIMUM	MINIMUM	AVERAGE
Plex IA	Plain	-65	2	22.55	21.50	22.02
	Plain	R.T.	3	56.80	31.20	43.42
	Notched	-65	3	12.50	6.44	8.71
	Notched	R.T.	5	9.47	4.50	6.28
Plex II	Plain	-65	3	27.75	25.00	26.42
	Plain	R.T.	3	72.00	58.90	67.40
	Notched	-65	3	7.65	7.15	7.33
	Notched	R.T.	4	10.16	7.50	8.42
5014XP	Plain	-65	3	33.8	27.8	30.9
	Plain	R.T.	3	45.7	42.0	44.0
	Plain	120	3	47.3	33.5	40.0
	Notched	-65	3	10.6	7.6	9.4
	Notched	R.T.	3	10.8	9.4	10.1
	Notched	120	3	11.5	10.2	11.2
5105XP	Plain	-65	3	32.6	30.4	31.7
	Plain	R.T.	3	67.6	57.3	64.2
	Plain	120	3	82.1	48.5	62.0
	Notched	-65	3	11.4	8.5	9.5
	Notched	R.T.	3	13.7	10.8	12.5
	Notched	120	3	17.4	14.6	16.4
Sierracin 611	Plain	-65	3	17.5	13.5	15.9
	Plain	R.T.	3	41.5	23.8	31.1
	Plain	120	3	57.8	38.8	46.6
	Notched	-65	3	4.5	2.8	3.7
	Notched	R.T.	3	8.6	2.1	5.3
	Notched	120	3	9.9	4.0	7.4
MACA	Plain	-65	3	38.0	34.4	36.3
	Plain	R.T.	3	40.8	39.0	40.0
	Plain	120	3	40.4	37.8	38.7
	Notched	-65	2	13.2	9.6	11.4
	Notched	R.T.	3	13.2	11.8	12.5
	Notched	120	3	16.4	14.3	15.5
Polymer K	Plain	-65	3	29.70	17.70	24.80
	Plain	R.T.	2	75.70	64.50	70.10
	Plain	120	3	43.60	40.80	42.00
	Notched	-65	3	4.30	4.00	4.20
	Notched	R.T.	3	11.80	10.70	11.40

WORK TO BREAK (Continued)

<u>MATERIAL</u>	<u>SPECIMEN CONDITION</u>	<u>TEST TEMP. °F</u>	<u>NUMBER SPECIMENS</u>	<u>RESULTS - IN. LBS./IN. WIDTH</u>		
				<u>MAXIMUM</u>	<u>MINIMUM</u>	<u>AVERAGE</u>
HE5621	Plain	-65	3	33.00	25.80	29.60
	Plain	R.T.	3	50.00	41.10	44.50
	Plain	120	3	87.10	44.20	59.10
	Notched	-65	3	6.20	5.20	5.50
	Notched	R.T.	3	21.60	18.20	20.20
	Notched	120	3	17.70	15.20	16.40

* Area Under Load-Deflection Curve

Test: Ultimate Tensile Stress vs. Temperature.

Materials: As Noted.

Note: Curves are of Average Values, Highest and Lowest Values Also Shown.

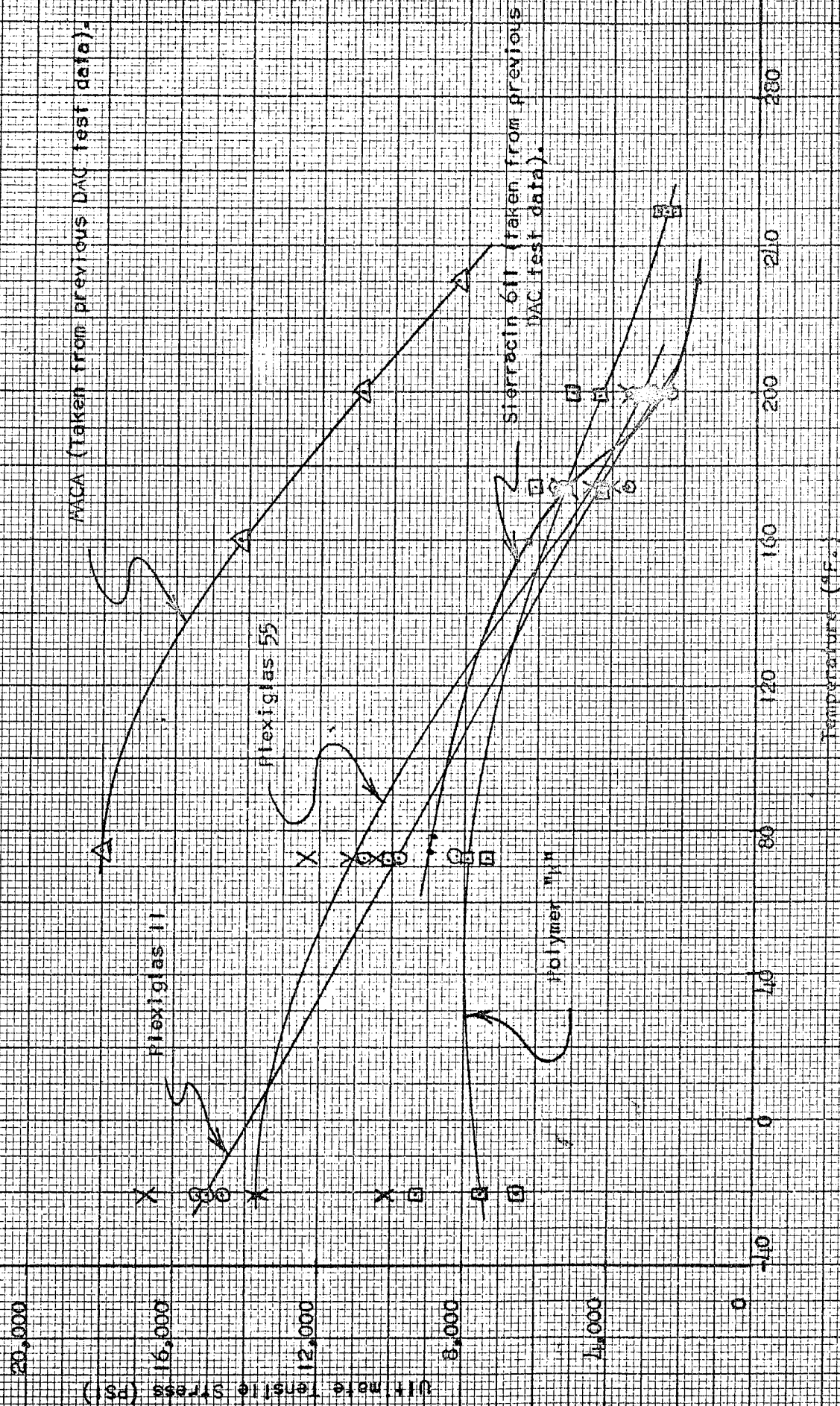

Test: Tensile Stress - Strain.
 Material: Plexiglas 55
 Legend: □ - 200°F
 ○ - 73°F
 △ - 175°F
 X - 200°F

Test Temp.	Type Failure
200°F.	Fracture
73°F.	Fracture
175°F.	Necked Down
200°F.	Necked Down

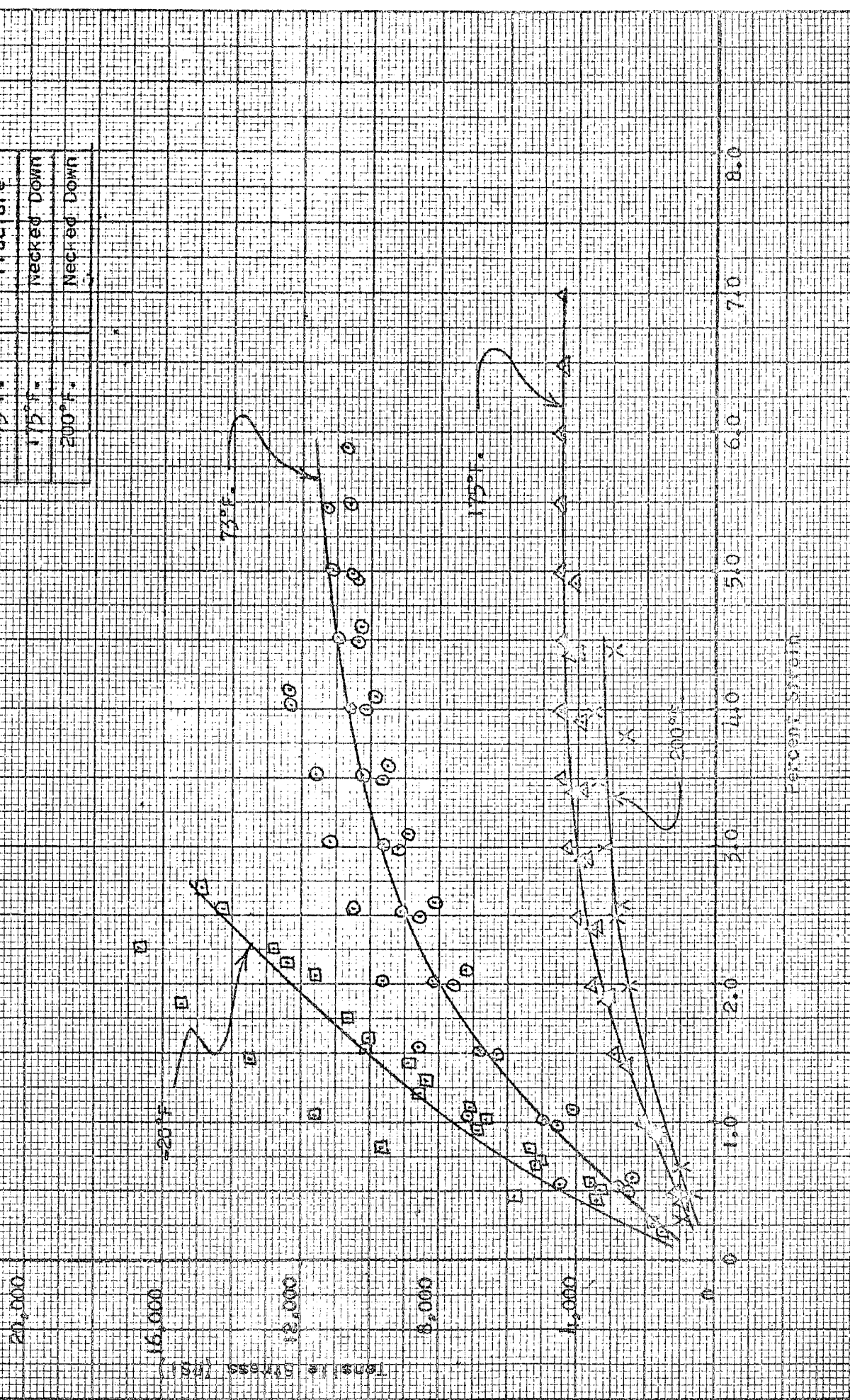

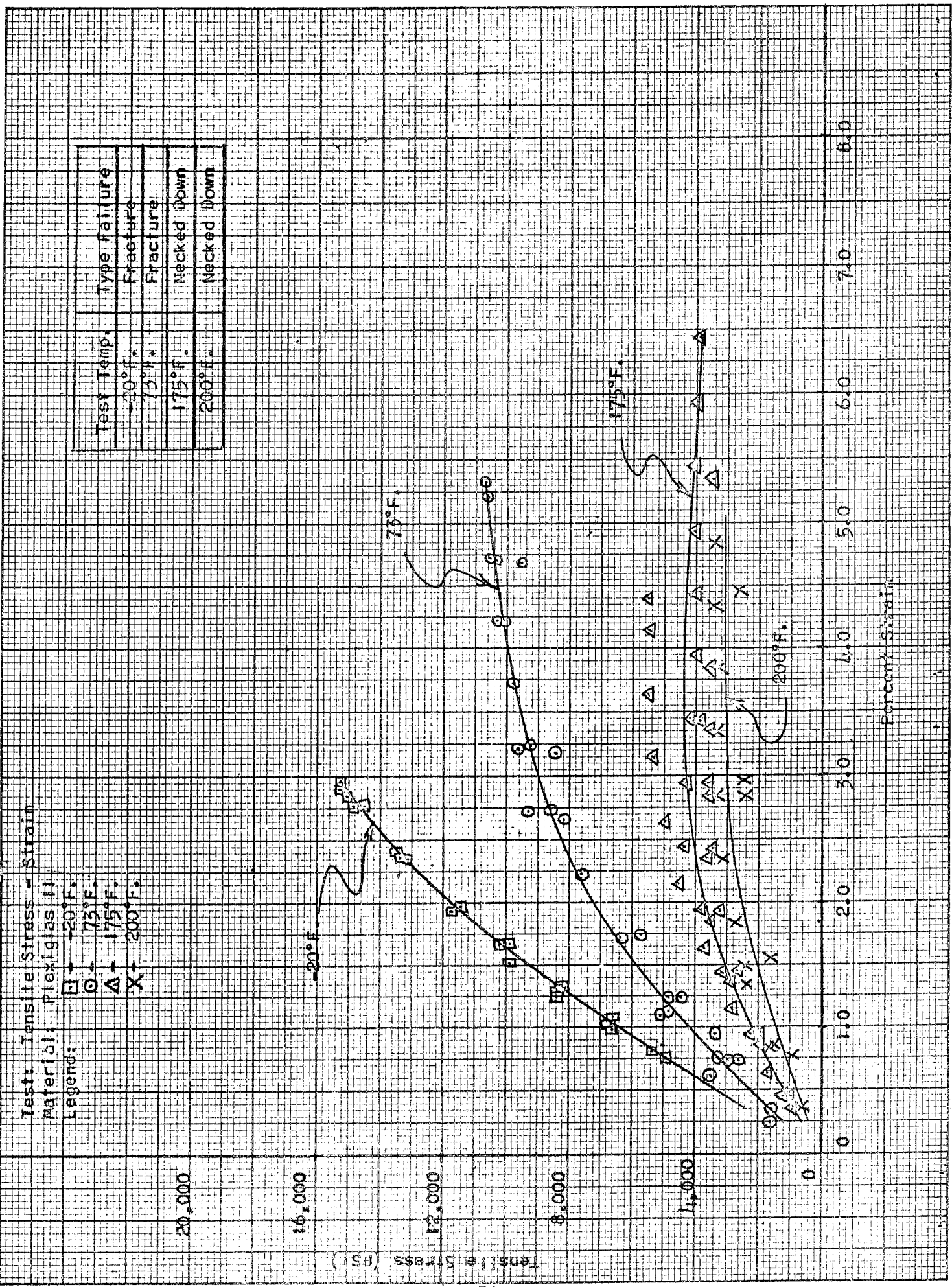

Test: Tensile Stress - Strain
 Material: Plexiglas II
 Legend:
 □ - 20°F.
 ○ - 73°F.
 △ - 175°F.
 X - 200°F.

Test Temp.	Type Failure
20°F.	Fracture
73°F.	Fracture
175°F.	Necked Down
200°F.	Necked Down

TENSILE STRESS (PSI)

PERCENT STRAIN

Test: Tensile Stress - Strain,
 Material: Sierracin 611,
 Notes: Curves taken from previous DAC Test Data.
 Legend: ○ - 75°F.
 △ - 160°F.
 ✕ - 200°F.
 □ - 250°F.

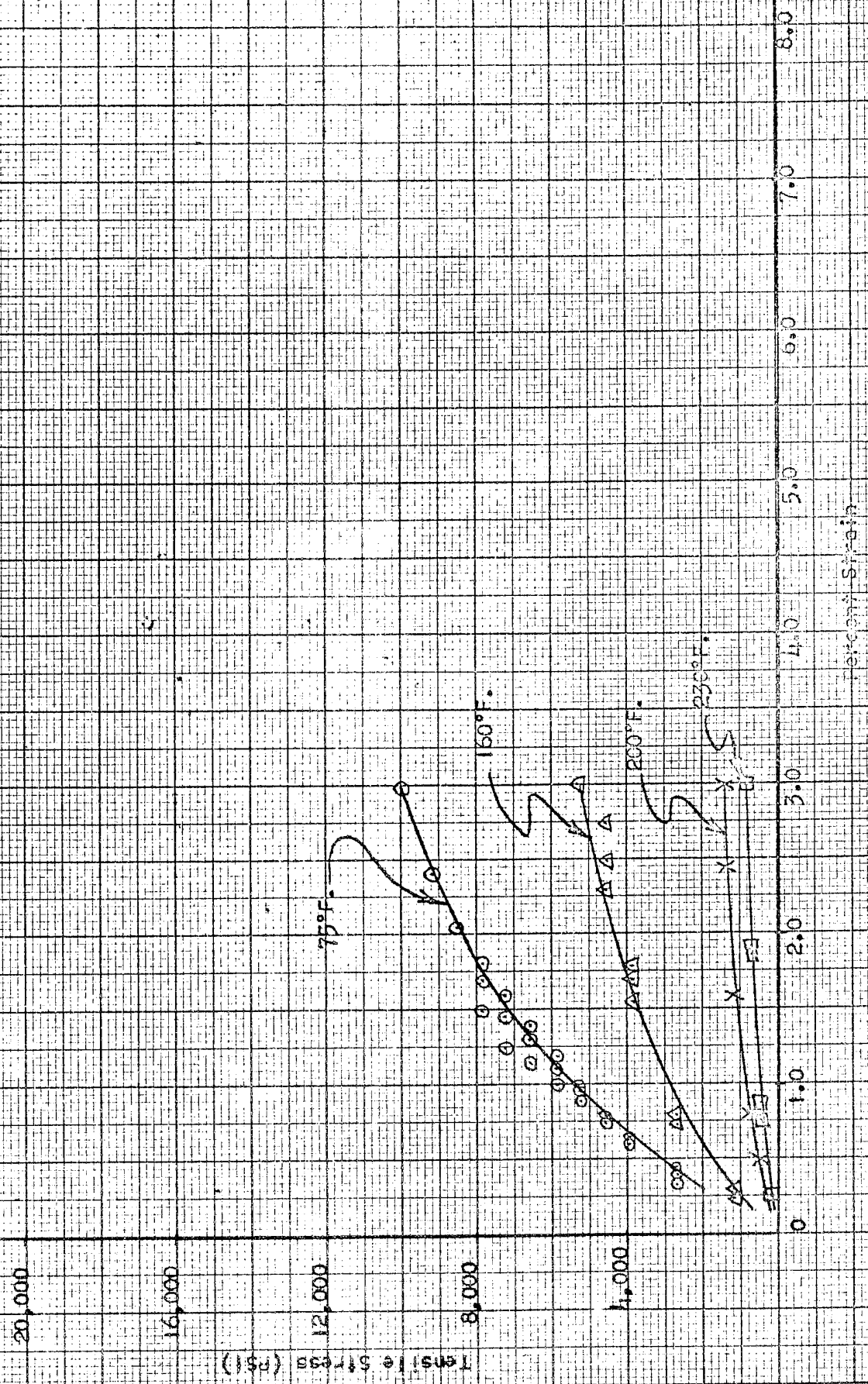

Test: Tensile Stress - Strain

Material: WACA

Note: Curves Taken From Previous DAC Test Data.

Legend:

○ - 75°F.

△ - 160°F.

X - 200°F.

□ - 230°F.

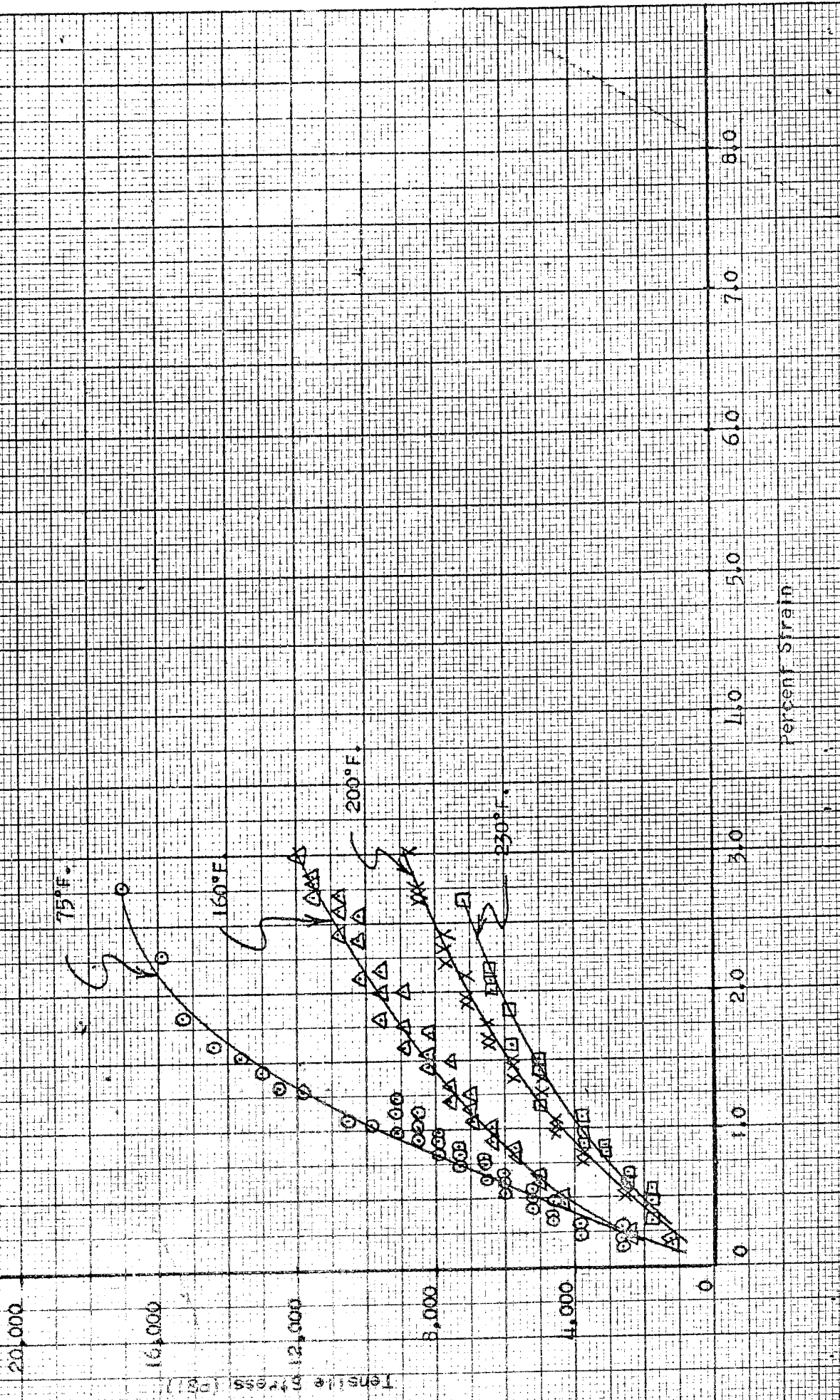

Tensile Stress (psi)

Percent Strain

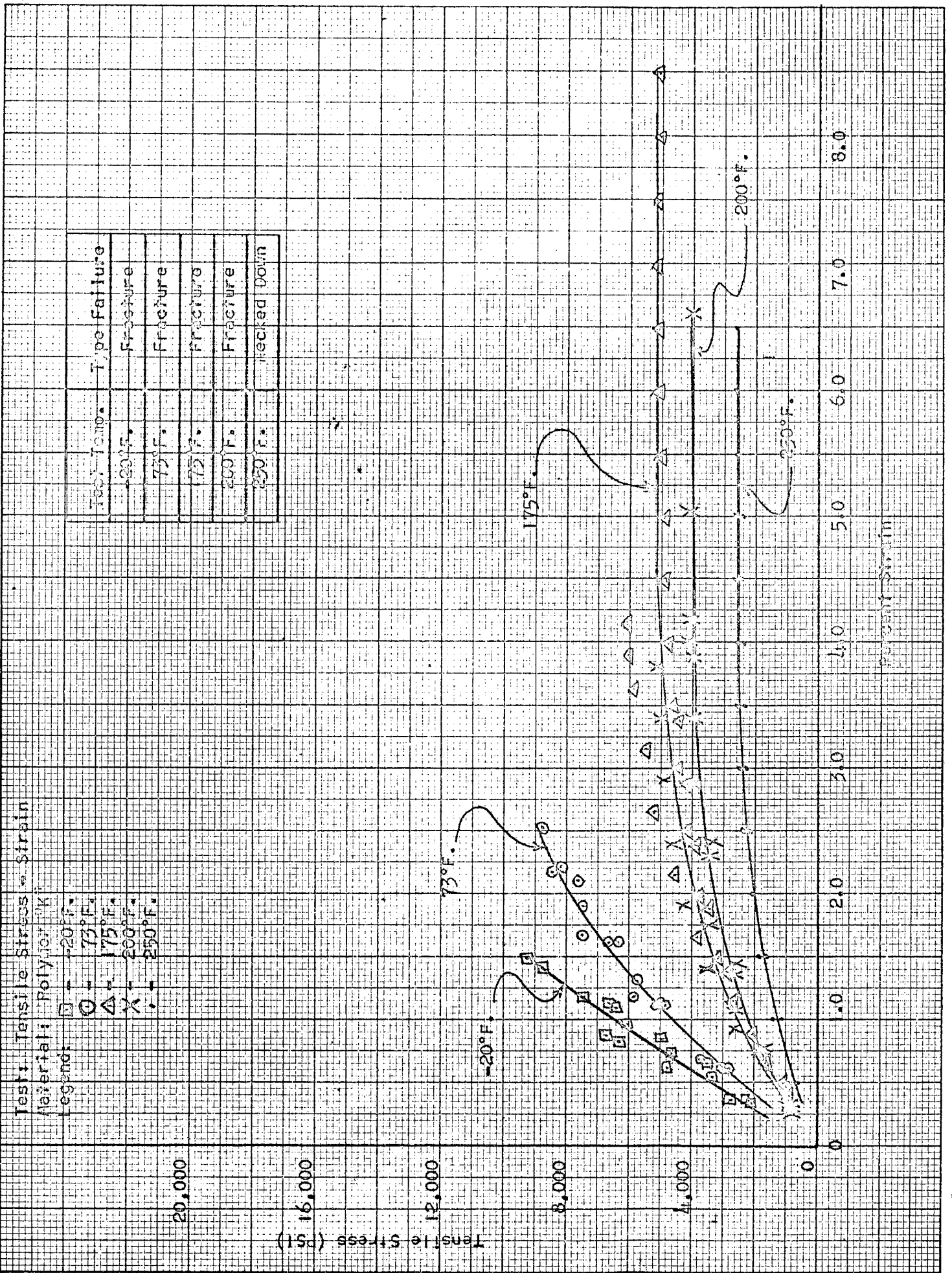

FLEXURAL STRENGTH

MATERIAL	SPECIMEN CONDITION	TEST TEMP. °F	DATA SOURCE	NO. SPEC.	FLEXURAL ULTIMATE - PSI		
					MAXIMUM	MINIMUM	AVERAGE
Plex IA	Plain	-65	B	5	18,750	17,570	18,020
	Plain	R.T.	B	5	16,100	14,200	15,004
	Plain	120	B	1	-	-	11,900
	Notched	-65	B	5	12,990	9,200	11,000
	Notched	R.T.	B	9	11,950	5,970	8,780
	Notched	120	B	2	7,520	6,110	6,815
Plex II	Plain	-65	B	3	21,000	20,200	20,460
	Plain	R.T.	B	3	18,600	17,820	18,170
	Plain	R.T.	L	8	18,300	15,300	17,100
	Plain	R.T.	D	-	-	-	20,100
	Notched	-65	B	3	10,430	10,110	10,290
	Notched	R.T.	L	4	10,000	7,400	8,800
	Notched	R.T.	D	-	-	-	19,600
5014XP	Plain	-65	B	3	23,250	21,500	22,600
	Plain	R.T.	B	3	19,500	19,110	19,300
	Plain	120	B	3	17,400	15,300	16,200
	Notched	-65	B	3	13,100	11,260	12,400
	Notched	R.T.	B	3	10,730	9,970	10,300
	Notched	120	B	3	9,630	9,240	9,500
5105XP	Plain	-65	B	3	21,825	21,300	21,490
	Plain	-60	L	2	22,890	20,500	21,700
	Plain	R.T.	B	3	19,500	18,700	19,210
	Plain	R.T.	L	2	17,520	17,460	17,490
	Plain	R.T.	D	-	-	-	24,500
	Plain	120	B	3	17,100	15,580	16,140
	Plain	120	L	2	13,760	13,370	13,560
	Notched	-65	B	3	12,155	10,417	11,090
	Notched	-60	L	2	14,017	12,980	13,500
	Notched	R.T.	B	3	10,970	9,900	10,510
	Notched	R.T.	L	2	9,350	9,000	9,180
	Notched	R.T.	D	-	-	-	14,500
	Notched	120	B	3	10,680	9,955	10,395
	Notched	120	L	2	9,350	9,260	9,300
	Sierracin 611	Plain	-65	B	3	15,160	13,100
Plain		R.T.	B	3	17,380	14,395	15,620
Plain		R.T.	L	10	20,600	14,400	17,000
Plain		R.T.	D	-	-	-	18,600
Plain		120	B	3	13,750	12,900	13,250
Notched		-65	B	3	7,450	5,980	6,740
Notched		R.T.	B	3	8,680	4,360	6,560
Notched		R.T.	L	6	10,100	8,380	9,400
Notched		R.T.	D	-	-	-	14,000
Notched		120	B	3	7,360	4,744	6,280

FLEXURAL STRENGTH (Continued)

<u>MATERIAL</u>	<u>SPECIMEN CONDITION</u>	<u>TEST TEMP. °F</u>	<u>DATA SOURCE</u>	<u>NO. SPEC.</u>	<u>FLEXURAL ULTIMATE - PSI</u>		
					<u>MAXIMUM</u>	<u>MINIMUM</u>	<u>AVERAGE</u>
MACA	Plain	-65	B	3	26,600	25,400	26,070
	Plain	R.T.	B	3	24,050	22,800	23,320
	Plain	R.T.	D	-	-	-	25,600
	Plain	120	B	3	22,000	21,500	21,800
	Notched	-65	B	2	15,900	14,000	14,950
	Notched	R.T.	B	3	13,460	12,690	13,070
	Notched	R.T.	D	-	-	-	18,600
	Notched	120	B	3	16,410	13,420	14,780
	Polymer K	Plain	-65	B	3	21,770	15,620
Plain		R.T.	B	2	21,680	20,750	21,215
Plain		120	B	3	17,100	16,900	17,010
Notched		-65	B	3	8,460	8,300	8,350
Notched		R.T.	B	3	10,610	10,420	10,530
Notched		120	B	3	9,390	8,760	9,140
HE5621		Plain	-65	B	3	22,900	21,000
	Plain	R.T.	B	3	18,860	18,280	18,560
	Plain	120	B	3	18,630	16,660	17,540
	Notched	-65	B	3	10,030	9,380	9,620
	Notched	R.T.	B	3	14,030	13,000	13,600
	Notched	120	B	3	12,200	11,860	12,060

FLEXURAL MODULUS

SOURCE: BOEING

MATERIAL	SPECIMEN CONDITION	TEST TEMP. °F	NUMBER SPECIMENS	RESULTS - PSI X 10 ³		
				MAXIMUM	MINIMUM	AVERAGE
Plex IA	Plain	-65	2	-	-	706
	Plain	R.T.	5	-	-	433.3
Plex II	Plain	-65	3	-	-	780
	Plain	R.T.	3	-	-	447
5014XP	Plain	-65	3	887	834	860
	Plain	R.T.	3	607	546	574
	Plain	120	3	487	447	465
5105XP	Plain	-65	3	852	740	794
	Plain	R.T.	3	515	504	509.5
	Plain	120	3	444	427.5	433
Sierracin	Plain	-65	3	754	718	738
	Plain	R.T.	3	518	501.5	512
	Plain	120	3	350	333.9	341
MACA	Plain	-65	3	1052	1043	1050
	Plain	R.T.	3	831.5	782	803
	Plain	120	3	697	685.5	692
Polymer K	Plain	-65	3	923	741	804
	Plain	R.T.	2	546	408	457
	Plain	120	3	414	396	407
	Notched	-65	3	865	837	848
	Notched	R.T.	3	534	524	528
	Notched	120	3	497	485	492
489-21	Plain	-65	3	900	837	872
	Plain	R.T.	3	472	431	458
	Plain	120	3	382	272	342
	Notched	-65	3	850	816	829
	Notched	R.T.	3	488	482	485
	Notched	120	3	508	439	466

IMPACT STRENGTH

DATA SOURCE: LOCKHEED

<u>MATERIAL</u>	<u>SPECIMEN CONDITION</u>	<u>TEST TEMP. °F</u>	<u>NUMBER SPECIMENS</u>	<u>RESULTS - FT. LBS./INCH</u>		
				<u>MAXIMUM</u>	<u>MINIMUM</u>	<u>AVERAGE</u>
Plex IA	Plain	R. T.	-			1.4
	Notched	R. T.	-			1.4
Plex II	Plain	R. T.	3	1.70	1.53	1.61
	Notched	R. T.	3	1.01	.98	.99
5105XP	Plain	R. T.	5	1.53	1.29	1.41
	Notched	R. T.	5	.54	.39	.45
Sierracin 611	Plain	R. T.	5	1.77	.87	1.18
	Notched	R. T.	6	.27	.18	.22
MACA	Plain	R. T.	5	1.53	1.33	1.45
	Notched	R. T.	5	.63	.57	.62
	Plain	-60	5	1.67	1.50	1.55
	Notched	-60	5	1.50	.33	.81

CREEP

Loaded At Elevated Temperatures (600 PSI)

Source: North American

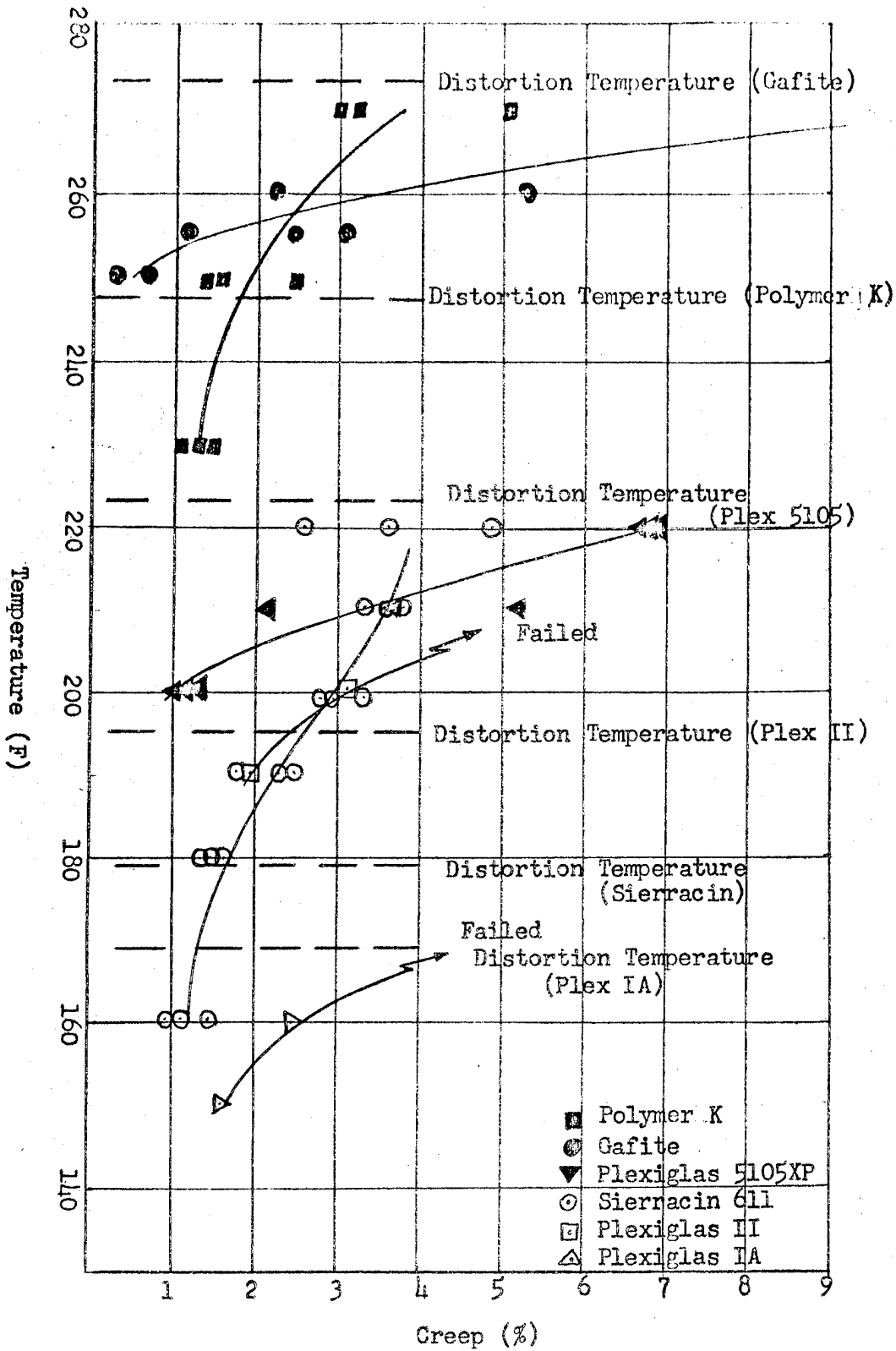

CREEP

Unloaded At Room Temperature

Source: North American

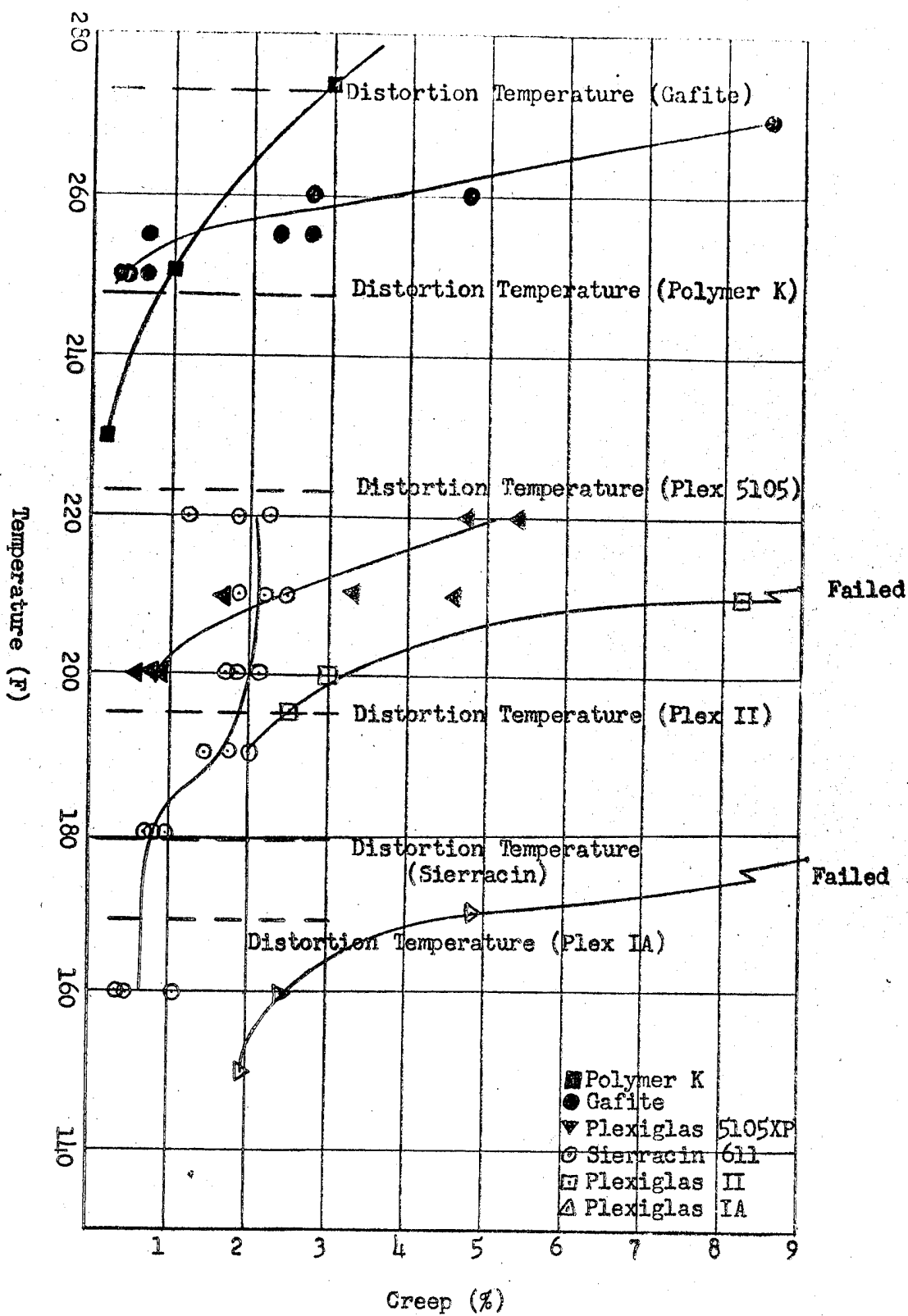

WEATHERING UNDER LOAD - TEXTILE

SOURCE: LOCKHEED

<u>MATERIAL</u>	<u>STRESS</u>	<u>TIME TO CRAZE</u>	<u>TIME TO FAIL</u>
Plex IA	2000	4 days	55 days
	4000	6 hours	3 days
Plex II	2000	39 days	155 days
	4000	4 days	12-1/2 days
	4000	3 days	15 days
	4000	16 days	28 days
	4000	7 days	13 days
	6000	1-1/2 hours	4-1/2 days
	6000	5-3/4 hours	1-1/4 days
5105XP	2000	>92 days	>92 days
	2000	>92 days	>92 days
	4000	8 days	45 days
	4000	8 days	45 days
	6000	20 hours	6 days
	6000	20 hours	6 days
Sierracin 611	2000	>145 days	>145 days
	2000	>145 days	>145 days
	4000	>145 days	>145 days
	4000	>145 days	>145 days
	4000	>93 days	>93 days
	4000	>18 days	>18 days
	4000	>18 days	>18 days
	6000	No Craze	42 days

OUTDOOR WEATHERING TESTS
UNDER CONSTANT TENSION

Source: Lockheed,
Data as of 8-18-52

Legend:

- Sierracin 611 Solid
- ◆ Sierracin 212 Solid
- ▲ Sierracin 611 Laminate
- ♣ 5105 XP Solid
- Plexiglas II Solid
- × Plexiglas IA Solid
- + Plexiglas II Laminate

Indicates test still going

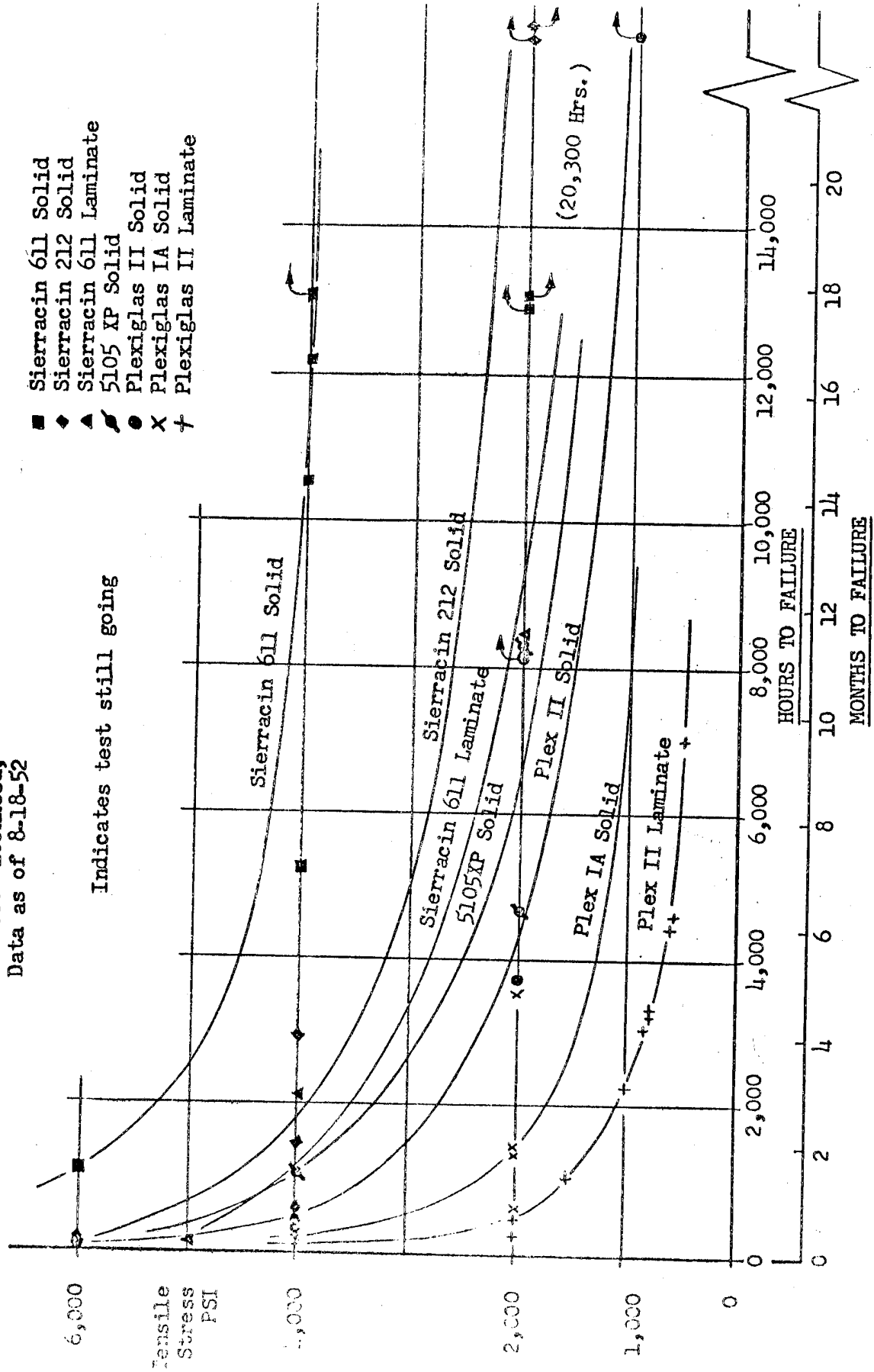

WEATHERING UNDER LOAD - FLEXURAL

SOURCE: DOUGLAS

<u>MATERIAL</u>	<u>STRESS - PSI</u>	<u>EXPOSURE</u>	<u>TIME TO CRAZE</u>	<u>TIME TO FAIL</u>
Plex II	10,000	Indoor	52 minutes	>110½ hours
	15,000	Indoor	39 minutes	890 hours
	3,000	Roof	613 hours	>627 hours
	5,000	Roof	124 hours	324 hours
	7,500	Roof	6 hours	28 hours
	10,000	Roof	45 minutes	23 hours
5105XP	10,000	Indoor	78 minutes	>110½ hours
	10,000	Indoor	60 minutes	240 hours
	3,000	Roof	>637 hours	>637 hours
	5,000	Roof	>600 hours	>600 hours
	7,500	Roof	29 hours	182 hours
	10,000	Roof	1.75 hours	23 hours
Sierracin 611	7,000	Indoor	No Craze	275 hours
	10,000	Indoor	No Craze	¼ to > 110½ hours
	15,000	Indoor	No Craze	27 to 53 minutes
	3,000	Roof	No Craze	>637 hours
	5,000	Roof	No Craze	>600 hours
	7,500	Roof	No Craze	14.5 to > 384 hours
10,000	Roof	No Craze	.5 to 70 hours	
MACA	10,000	Indoor	115 minutes	>110½ hours
	15,000	Indoor	89 minutes	127 hours
	3,000	Roof	>637 hours	>637 hours
	5,000	Roof	>600 hours	>600 hours
	7,500	Roof	148 hours	206 to > 384 hours
	10,000	Roof	7.5 hours	32 hours

LONG TIME FLEXURAL TEST

PLEX IA - 1/4 INCH THICKNESS

Data Source: Boeing

<u>Specimen Number</u>	<u>Condition</u>	<u>Stress (PSI)</u>	<u>Time to Craze (Hours)</u>	<u>Time to Fail (Hours)</u>
1089	Plain	7000	21*	>4128.5
1090	Plain	7000	21*	>4128.5
1091	Plain	7000	21*	>4128.5
1085	Plain	9000	8	71.5
1086	Plain	9000	8	70
1087	Plain	9000	8	70
1088	Plain	9000	8	94
1081	Plain	11000	No Craze	4.25
1082	Plain	11000	No Craze	5.00
1083	Plain	11000	No Craze	6.00
1084	Plain	11000	No Craze	6.00
1069	Notched	4000	No Craze	>4128.5
1070	Notched	4000	No Craze	>4128.5
1071	Notched	4000	240*	>4128.5
1065	Notched	5000	144.5*	>4108.75
1066	Notched	5000	144.5*	>4108.75
1067	Notched	5000	144.5*	1824
1068	Notched	5000	144.5*	>4108.75

Flexural Control Static Ultimate Stress (PSI)

<u>Condition</u>	<u>No. Specs.</u>	<u>Max.</u>	<u>Min.</u>	<u>Average</u>
Plain	5	16,100	14,200	15,000
Notched	9	11,950	5,970	8,780

* Lightly Crazed

LONG TIME FLEXURAL TEST

PLEX II

Data Source: Boeing

<u>Matl. Thick.</u>	<u>Specimen Number</u>	<u>Condition</u>	<u>Stress (PSI)</u>	<u>Time to Craze (Hours)</u>	<u>Time to Fail (Hours)</u>
1/4	997	Plain	5,000	3576 *	>7656
1/4	998	Plain	5,000	3576 *	>7656
1/4	999	Plain	5,000	3576 *	>7656
1/4	1000	Plain	5,000	3576 *	>7656
1/4	1001	Plain	7,000	47 *	>7656
1/4	1002	Plain	7,000	47 *	>7656
1/4	1003	Plain	7,000	47 *	>7656
1/4	1004	Plain	7,000	47 *	>7656
1/4	1005	Plain	9,000	47 **	>7656
1/4	1006	Plain	9,000	47 **	>7656
1/4	1007	Plain	9,000	47 **	5296
1/4	1008	Plain	9,000	47 **	>7656
1/4	1011	Plain	11,000	47 **	399
1/4	1012	Plain	11,000	47 **	879
1/4	981	Notched	3,000	No Craze	> 7104
1/4	982	Notched	3,000	No Craze	> 7104
1/4	983	Notched	3,000	No Craze	> 7104
1/4	984	Notched	3,000	No Craze	> 7104
1/4	985	Notched	4,000	No Craze	>7656
1/4	986	Notched	4,000	No Craze	>7656
1/4	987	Notched	4,000	No Craze	>7656
1/4	988	Notched	4,000	No Craze	>7656
1/4	989	Notched	5,000	2520 *	> 7656
1/4	991	Notched	5,000	3576 *	>7656
1/4	992	Notched	5,000	3576 *	>7656
1/4	993	Notched	6,000	216 *	1800
1/4	994	Notched	6,000	216 *	2112
1/4	995	Notched	6,000	216 *	1344
1/4	996	Notched	6,000	216 *	600
3/4	957	Plain	5,000	4032 *	> 8112
3/4	958	Plain	5,000	4032 *	>8112
3/4	959	Plain	5,000	2234 *	>7608
3/4	960	Plain	5,000	3528 *	>7608
3/4	961	Plain	7,000	351 **	> 8136
3/4	962	Plain	7,000	351 **	> 8136

LONG TIME FLEXURAL TEST

PLEX II (Continued)

Data Source: Boeing

<u>Matl. Thick.</u>	<u>Specimen Number</u>	<u>Condition</u>	<u>Stress (PSI)</u>	<u>Time to Craze (Hours)</u>	<u>Time to Fail (Hours)</u>
3/4	963	Plain	7,000	48.25 **	>7608
3/4	964	Plain	7,000	48.25 **	>7608
3/4	965	Plain	9,000	185.5 **	>7800
3/4	966	Plain	9,000	185.5 **	6624
3/4	941	Notched	3,000	No Craze	>8136
3/4	942	Notched	3,000	No Craze	>8136
3/4	943	Notched	3,000	No Craze	>7608
3/4	944	Notched	3,000	No Craze	>7608
3/4	945	Notched	4,000	3552 *	>7608
3/4	946	Notched	4,000	4056 *	>8136
3/4	947	Notched	4,000	4056 *	>8136
3/4	948	Notched	4,000	4272 *	>7296
3/4	949	Notched	5,000	2424 *	>7800
3/4	950	Notched	5,000	2232 *	>7608
3/4	951	Notched	5,000	1920 *	>7296
3/4	952	Notched	5,000	1920 *	2064

Flexural Control Static Ultimate Stress (PSI)

<u>Condition</u>	<u>No. Specs.</u>	<u>Max.</u>	<u>Min.</u>	<u>Average</u>
.25 Plain	3	18,600	17,800	18,200
.25 Notched	3	9,350	8,100	8,750
.75 Plain	3	16,100	15,800	15,900
.75 Notched	3	10,500	8,400	9,500

* Lightly Crazed

** Heavily Crazed

LONG TIME FLEXURAL TEST

5105 XP MATERIAL - 1/4 INCH THICKNESS

Data Source: Boeing

<u>Specimen Number</u>	<u>Condition</u>	<u>Stress (PSI)</u>	<u>Time to Craze (Hours)</u>	<u>Time to Fail (Hours)</u>
1418	Plain	9,200	23 Hours	2424 - 2472
1419	Plain	9,200	27 1/2 Hrs.	1511 - 1534
1420	Plain	9,200	3 Hours	4536 - 4540
1424	Plain	11,100	3 Hours	392 Hours
1425	Plain	11,100	3 Hours	291 Hours
1426	Plain	11,100	3 Hours	286 Hours
1430	Plain	13,000	1.7 Hours	10.7 Hours
1431	Plain	13,000	1.7 Hours	15 - 23 Hours
1432	Plain	13,000	2.0 Hours	15 - 23 Hours
1436	Plain	14,800	23 Min.	61 Min.
1437	Plain	14,800	-	25 Min.
1438	Plain	14,800	30 Min.	107 Min.
1421	Notched	5,000	No Craze	>6500
1422	Notched	5,000	No Craze	>6500
1423	Notched	5,000	No Craze	>6500
1427	Notched	6,000	No Craze	>6500
1428	Notched	6,000	5326	>6500
1429	Notched	6,000	5326	>6500
1433	Notched	7,000	28.5 Hours	5064 - 5088
1434	Notched	7,000	52.7 Hours	2928 - 2935
1435	Notched	7,000	52.7 Hours	54 Hours
1439	Notched	8,000	No Craze	3 Min.
1440	Notched	8,000	-	3 Min.
1441	Notched	8,000	-	-

Flexural Control Static Ultimate Stress (PSI)

<u>Condition</u>	<u>No. Specs.</u>	<u>Max.</u>	<u>Min.</u>	<u>Average</u>
Plain	3	19,500	18,700	19,200
Notched	3	11,000	9,900	10,500

NOTE: FINAL RESULTS

LONG TIME FLEXURAL TEST

S611 MATERIAL - 1/4 INCH THICKNESS

Data Source: Boeing

<u>Specimen Number</u>	<u>Condition</u>	<u>Stress (PSI)</u>	<u>Time to Fail (Hours)</u>
1460	Plain	8,300	54 - 117
1461	Plain	8,300	36.5
1462	Plain	8,300	2.7
1466	Plain	10,000	1.6
1467	Plain	10,000	1.0
1468	Plain	10,000	3.0
1472	Plain	6,000	>6500
1473	Plain	6,000	>6500
1474	Plain	6,000	>6500
1478	Plain	7,000	77 - 141
1479	Plain	7,000	5088-5112
1480	Plain	7,000	245 - 309
1463	Notched	4,200	11.2
1464	Notched	4,200	4.7
1465	Notched	4,200	21 - 24
1469	Notched	5,000	6.2
1470	Notched	5,000	13
1471	Notched	5,000	30
1475	Notched	5,800	20 Sec.
1476	Notched	5,800	98 Min.
1477	Notched	5,800	0
1481	Notched	3,400	1870 - 4896
1482	Notched	3,400	>6500
1495	Notched	3,400	102 - 166 Hrs.

Note: No Craziing was observed

Flexural Control Static Ultimate Stress (PSI)

<u>Condition</u>	<u>No. Specs.</u>	<u>Max.</u>	<u>Min.</u>	<u>Average</u>
Plain	3	17,400	14,400	15,600
Notched	3	8,700	4,400	6,600

NOTE: FINAL RESULTS

LONG TIME FLEXURAL TEST

S-212 - 3/4 INCH THICKNESS

Data Source: Boeing

<u>Specimen Number</u>	<u>Condition</u>	<u>Stress (PSI)</u>	<u>Time to Fail (Hours)</u>
633	Plain	5,000	>8136
634	Plain	5,000	>8136
637	Plain	7,000	3434
638	Plain	7,000	6936
641	Plain	9,000	352.8
642	Plain	9,000	161.75
615	Notched	2,500	>7800
616	Notched	2,500	>7800
601	Notched	3,000	>8136
602	Notched	3,000	>8136
617	Notched	3,500	305.25
618	Notched	3,500	377.25
603	Notched	4,000	3.25
614	Notched	4,000	5.25

Note: No Craziing was observed

Flexural Control Static Ultimate Stress (PSI)

<u>Condition</u>	<u>No. Specs.</u>	<u>Max.</u>	<u>Min.</u>	<u>Average</u>
Plain	6	17,400	10,800	14,400
Notched	4	6,100	5,200	5,600

LONG TIME FLEXURAL TEST

S-212-A - 3/4 INCH THICKNESS

Data Source: Boeing

<u>Specimen Number</u>	<u>Condition</u>	<u>Stress (PSI)</u>	<u>Time to Fail (Hours)</u>
693	Plain	5,000	>5336
694	Plain	5,000	>2568
697	Plain	7,000	432
698	Plain	7,000	432
701	Plain	9,000	43
702	Plain	9,000	41.5
669	Notched	3,000	7056
670	Notched	3,000	2232
673	Notched	4,000	192
674	Notched	4,000	216.75
679	Notched	5,000	41.5

Note: No Craziing was observed

Flexural Control Static Ultimate Stress (PSI)

<u>Condition</u>	<u>No. Specs.</u>	<u>Max.</u>	<u>Min.</u>	<u>Average</u>
Plain	4	19,000	16,900	18,000
Plain	4	11,200	8,800	9,700

LONG TIME FLEXURAL TEST

S-53

Data Source: Boeing

<u>Matl. Thick.</u>	<u>Specimen Number</u>	<u>Condition</u>	<u>Stress (PSI)</u>	<u>Time to Craze (Hours)</u>	<u>Time to Fail (Hours)</u>
1/4	916	Plain	9,000	28.25 *	>4130.5
1/4	917	Plain	9,000	28.25 *	>4130.5
1/4	918	Plain	9,000	28.25 *	>4130.5
1/4	913	Plain	11,000	28.25	250
1/4	914	Plain	11,000	28.25	250
1/4	915	Plain	11,000	28.25	290
1/4	892	Notched	5,000	No Craze	>4107.75
1/4	893	Notched	5,000	3100.5 *	>4107.75
1/4	889	Notched	6,000	No Craze	>4108.25
1/4	890	Notched	6,000	3101 *	1344
1/4	891	Notched	6,000	No Craze	>4108.25
3/4	821	Notched	3,000	No Craze	>8112
3/4	822	Notched	3,000	No Craze	>8112
3/4	825	Notched	4,000	No Craze	>8112
3/4	826	Notched	4,000	No Craze	>8112
3/4	829	Notched	5,000	No Craze	2016
3/4	830	Notched	5,000	No Craze	>7800

Flexural Control Static Ultimate Stress (PSI)

<u>Matl. Thick.</u>	<u>Condition</u>	<u>No. Specs.</u>	<u>Max.</u>	<u>Min.</u>	<u>Average</u>
.25	Plain	4	19,800	14,500	18,000
.25	Notched	4	10,200	8,100	9,500
.75	Plain	4	17,500	16,300	16,900
.75	Notched	4	9,800	8,100	9,000

* Lightly Crazed

LONG TIME FLEXURAL TEST

MACA MATERIAL - 1/4 INCH THICKNESS

Data Source: Boeing

<u>Specimen Number</u>	<u>Condition</u>	<u>Stress (PSI)</u>	<u>Time to Craze (Hours)</u>	<u>Time to Fail (Hours)</u>
1519	Plain	11,000	23.5 Hrs.	6425 - 6450
1520	Plain	11,000	23.5 Hrs.	6425 - 6450
1521	Plain	11,000	23.6 Hrs.	4966 - 5038
1525	Plain	14,000	52 Min.	221 Hrs.
1526	Plain	14,000	21 Hrs.	486-502 Hrs.
1527	Plain	14,000	21 Hrs.	198-214 Hrs.
1531	Plain	16,300	-	18 Min.
1532	Plain	16,300	1 Hr. 7 Min.	31-47 Hrs.
1533	Plain	16,300	1 Hr. 10 Min.	30.6 Hrs.
1537	Plain	18,600	-	35 Min.
1538	Plain	18,600	50 Min.	7-23 Hrs.
1539	Plain	18,600	50 Min.	7-23 Hrs.
1522	Notched	6,500	No Craze	>6500
1523	Notched	6,500	No Craze	>6500
1524	Notched	6,500	No Craze	>6500
1528	Notched	7,900	5014	>6500
1529	Notched	7,900	No Craze	4824-4848
1530	Notched	7,900	No Craze	>6500
1534	Notched	9,200	No Craze	293 Hrs.
1535	Notched	9,200	No Craze	126-166 Hrs.
1536	Notched	9,200	No Craze	125-166 Hrs.
1540	Notched	10,500	No Craze	7-23 Hrs.
1541	Notched	10,500	No Craze	7-23 Hrs.
1542	Notched	10,500	No Craze	55-119 Hrs.

Flexural Control Static Ultimate Stress (PSI)

<u>Condition</u>	<u>No. Specs.</u>	<u>Max.</u>	<u>Min.</u>	<u>Average</u>
Plain	3	24,000	22,800	23,300
Notched	3	13,500	12,700	13,100

NOTE: FINAL RESULTS

LONG TIME FLEXURAL TEST
POLYMER "K"
 DATA SOURCE: BOEING

<u>Material Thickness</u>	<u>Specimen Number</u>	<u>Condition</u>	<u>Stress PSI</u>	<u>Time to Fail Hours</u>
1/4	1670	Plain	8520	>2136
	1671	Plain	8520	>2136
	1672	Plain	8520	>2136
	1676	Plain	10,640	>2136
	1677	Plain	10,640	120
	1678	Plain	10,640	>2136
	1682	Plain	12,780	2.5
	1683	Plain	12,780	13
	1684	Plain	12,780	.08
	1688	Plain	17,030	Immediate
	1689	Plain	17,030	Immediate
	1690	Plain	17,030	Immediate
	1667	Notched	4220	>2136
	1668	Notched	4220	>2136
	1669	Notched	4220	>2136
	1673	Notched	5270	>2136
	1674	Notched	5270	>2136
	1675	Notched	5270	>2136
	1679	Notched	6320	4.8
	1680	Notched	6320	1200
	1681	Notched	6320	>2136
	1685	Notched	8430	Immediate
	1686	Notched	8430	Immediate
	1687	Notched	8430	.03

NOTE:

*Material did not craze.

LONG TIME FLEXURAL TEST

HE 5621

DATA SOURCE: BOEING

<u>Material Thickness</u>	<u>Specimen Number</u>	<u>Condition</u>	<u>Stress PSI</u>	<u>Time to Fail Hours</u>
1/4	1622	Plain	7430	>2136
	1623	Plain	7430	>2136
	1624	Plain	7430	>2136
	1628	Plain	9280	360
	1629	Plain	9280	>2136
	1630	Plain	9280	>2136
	1634	Plain	11,130	78
	1635	Plain	11,130	53
	1636	Plain	11,130	190
	1640	Plain	14,850	.20
	1641	Plain	14,850	.02
	1642	Plain	14,850	.05
	1619	Notched	5440	>2136
	1620	Notched	5440	>2136
	1621	Notched	5440	>2136
	1625	Notched	6800	>2136
	1626	Notched	6800	>2136
	1627	Notched	6800	>2136
	1631	Notched	8160	>2136
	1632	Notched	8160	>2136
	1633	Notched	8160	>2136
	1637	Notched	10,880	7
	1638	Notched	10,880	Immediate
	1639	Notched	10,880	Immediate

NOTE:

MATERIAL DID NOT CRAZE

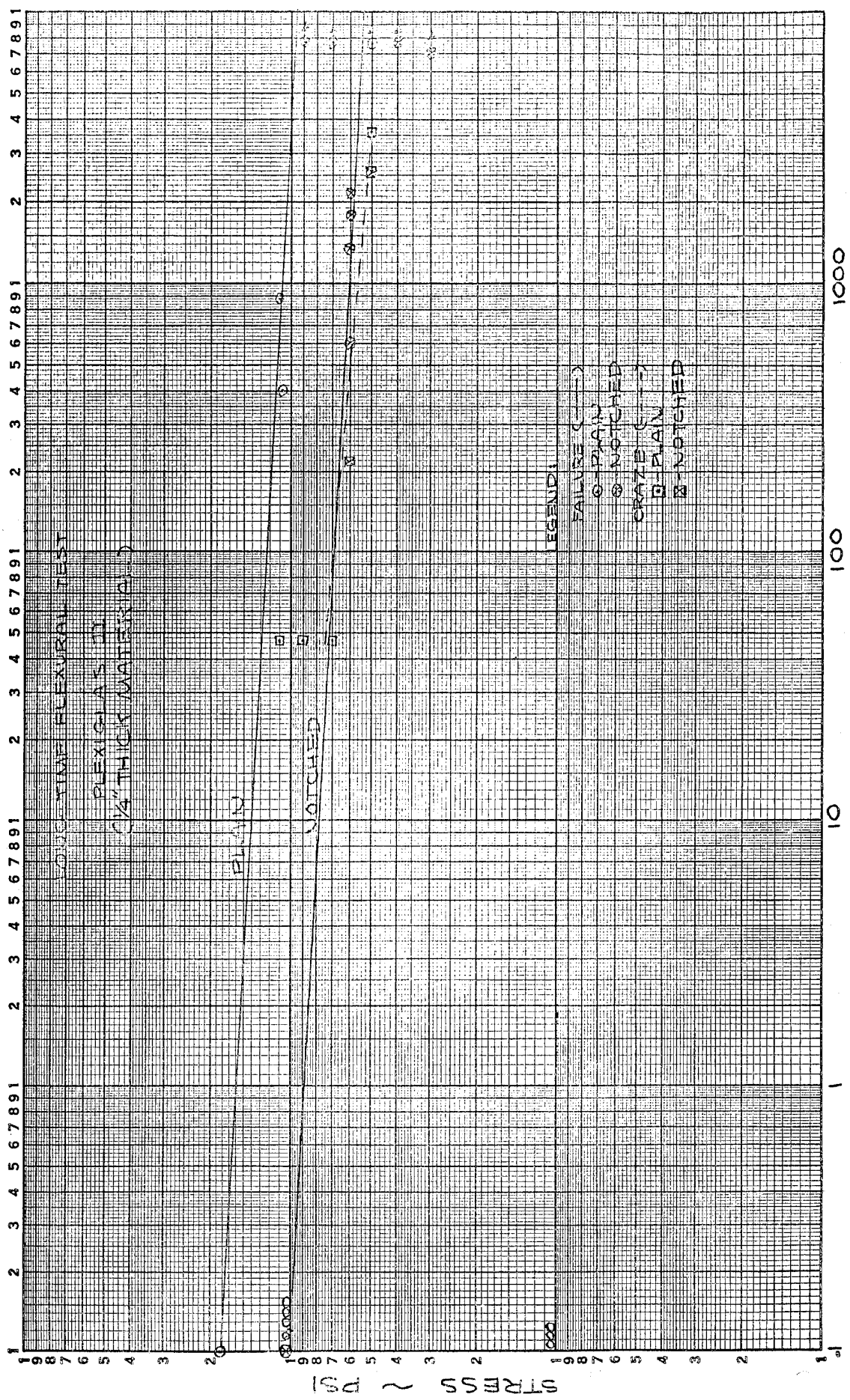

359-125G KEUFFEL & ESSER CO.
 Logarithmic, 3 X 5 Cycles.
 F. C. C. Sheet.
 MADE IN U. S. A.

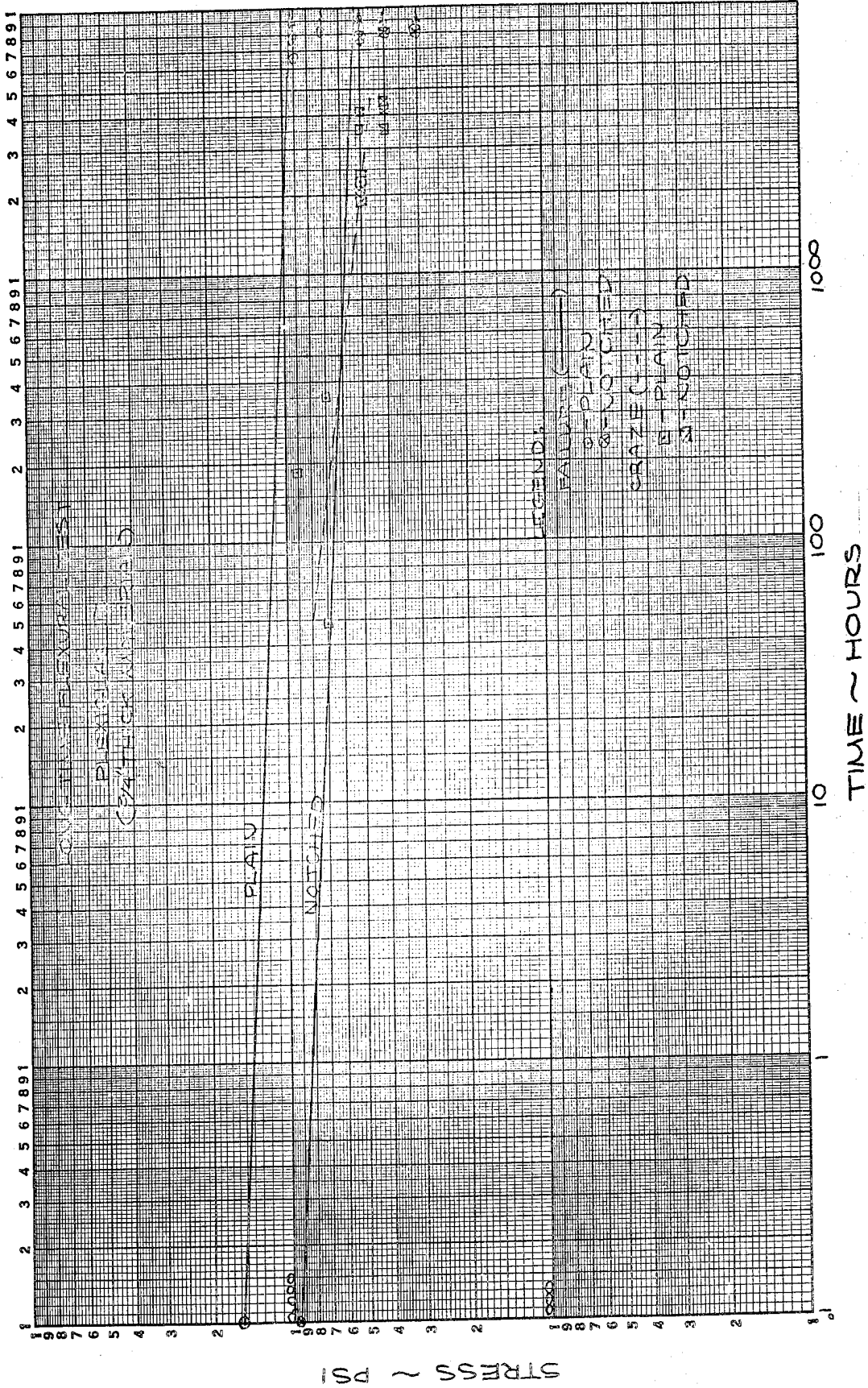

STRESS ~ PSI

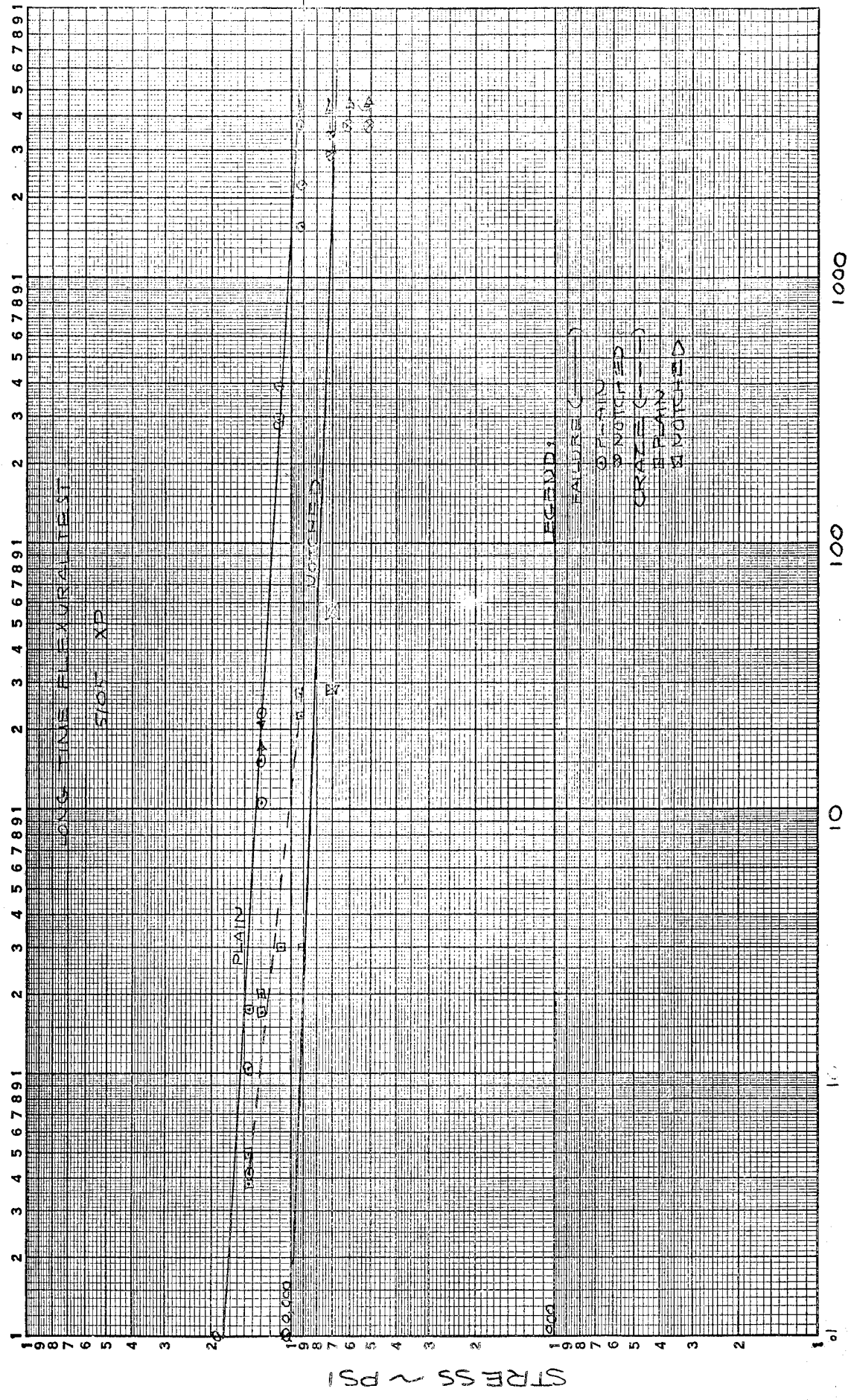

STRESS ~ PSI

TIME ~ HOURS

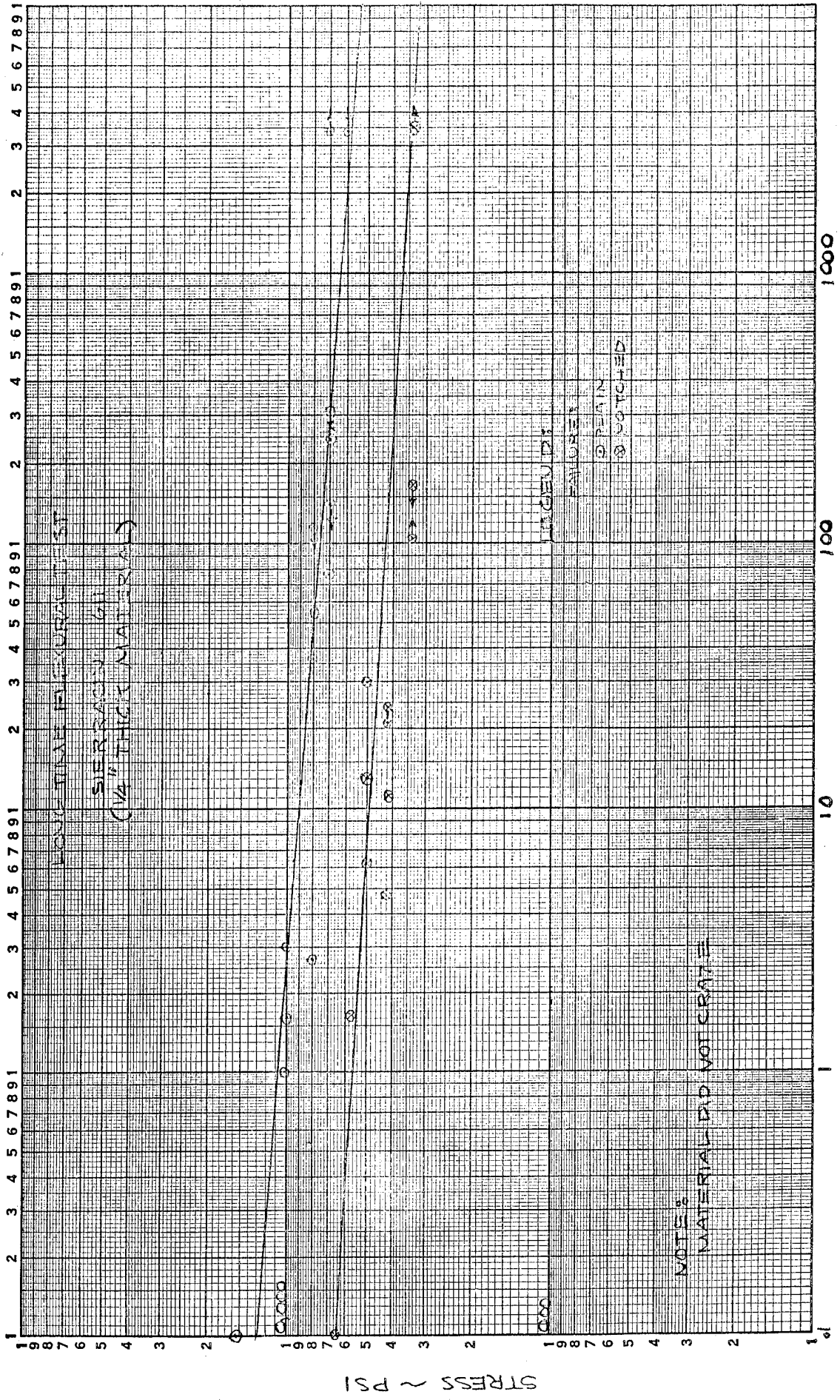

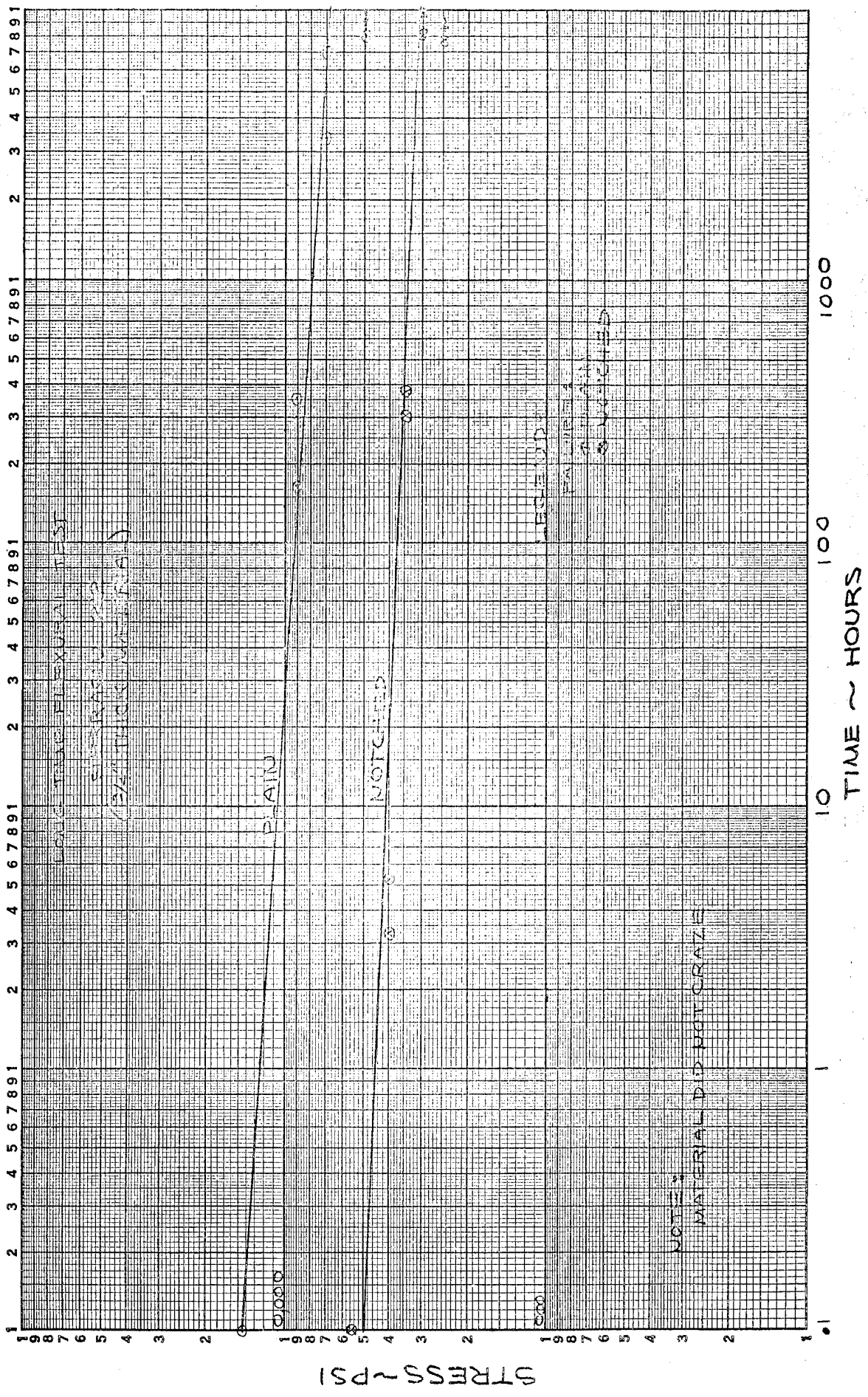

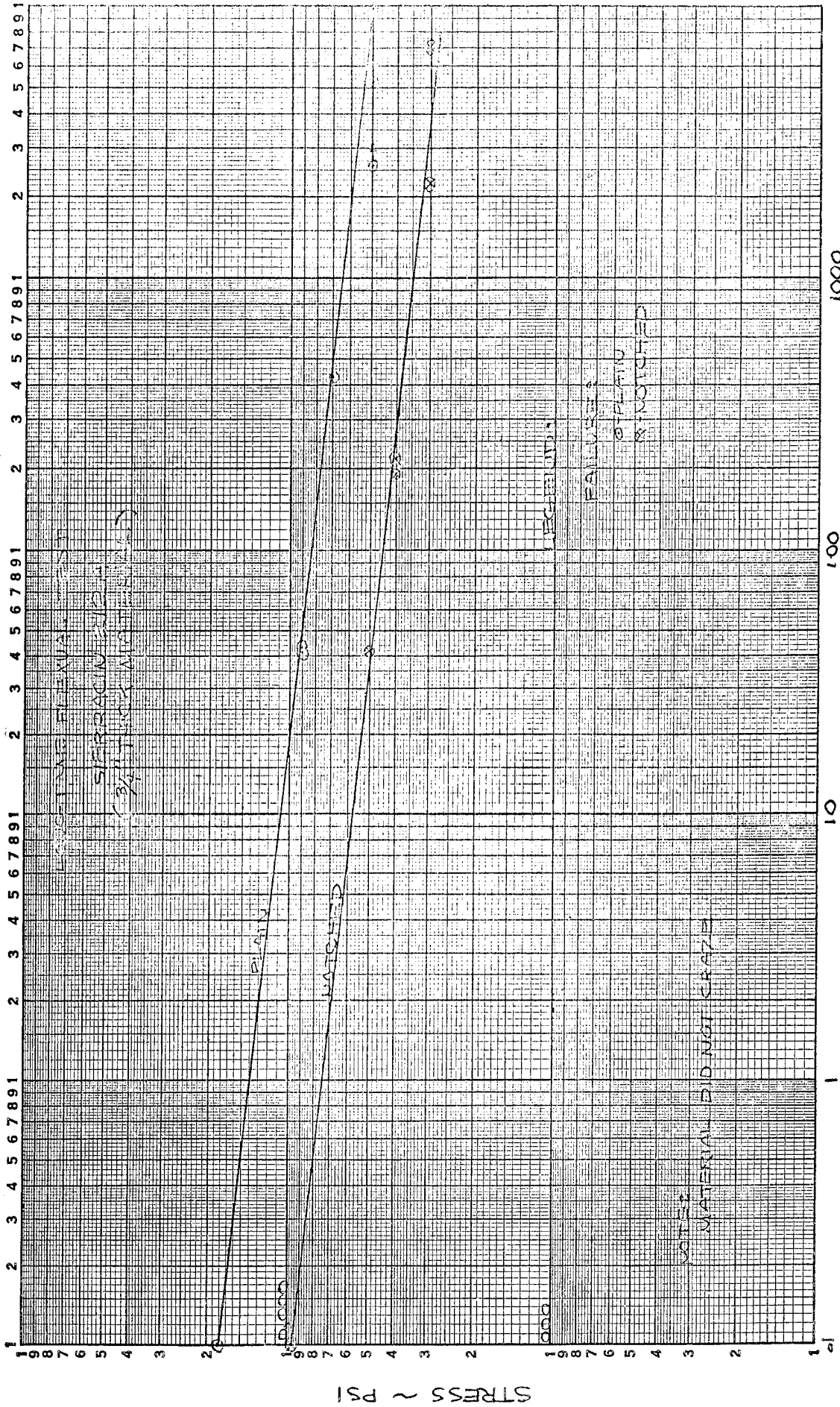

STRESS ~ PSI

TIME ~ HOURS

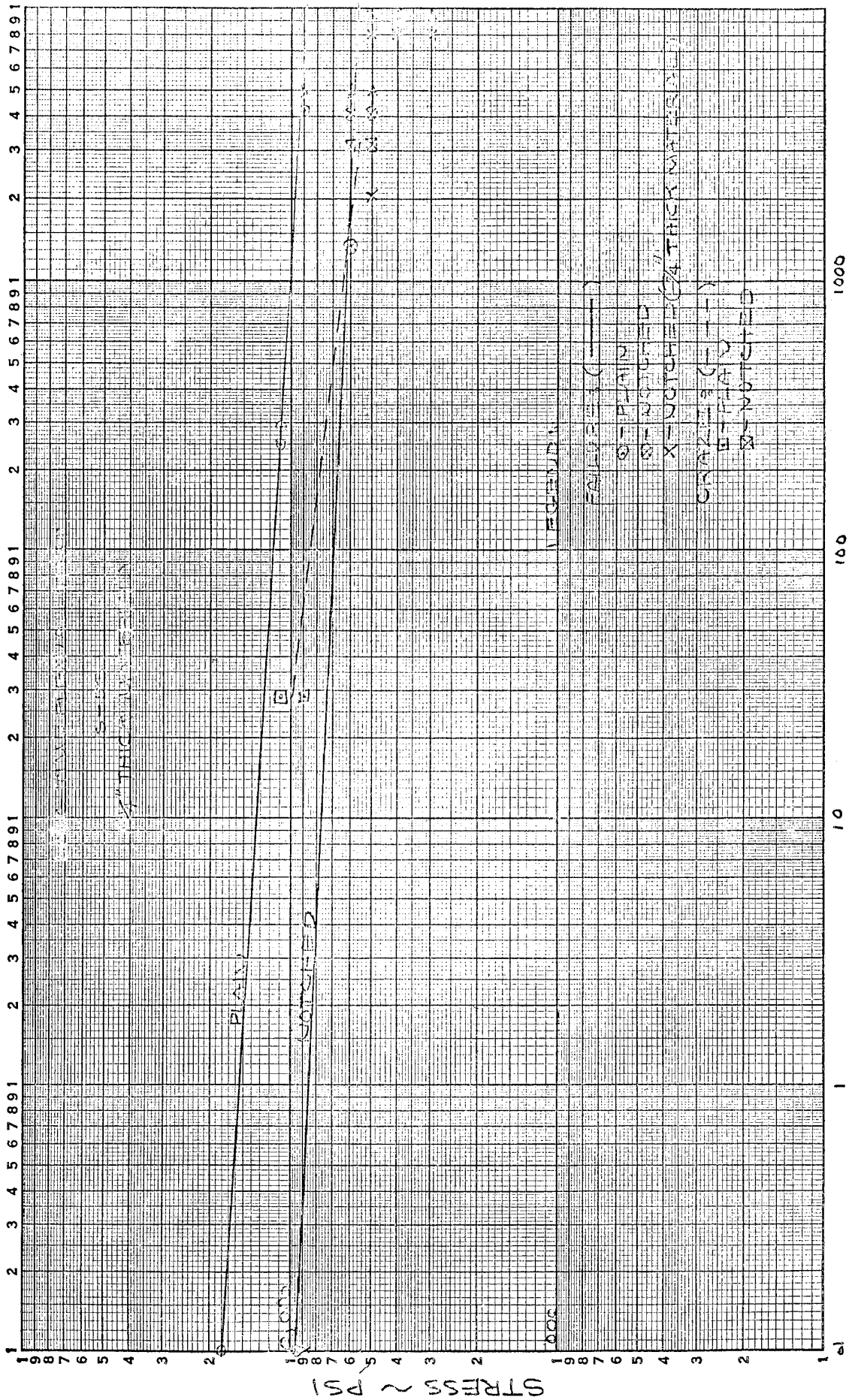

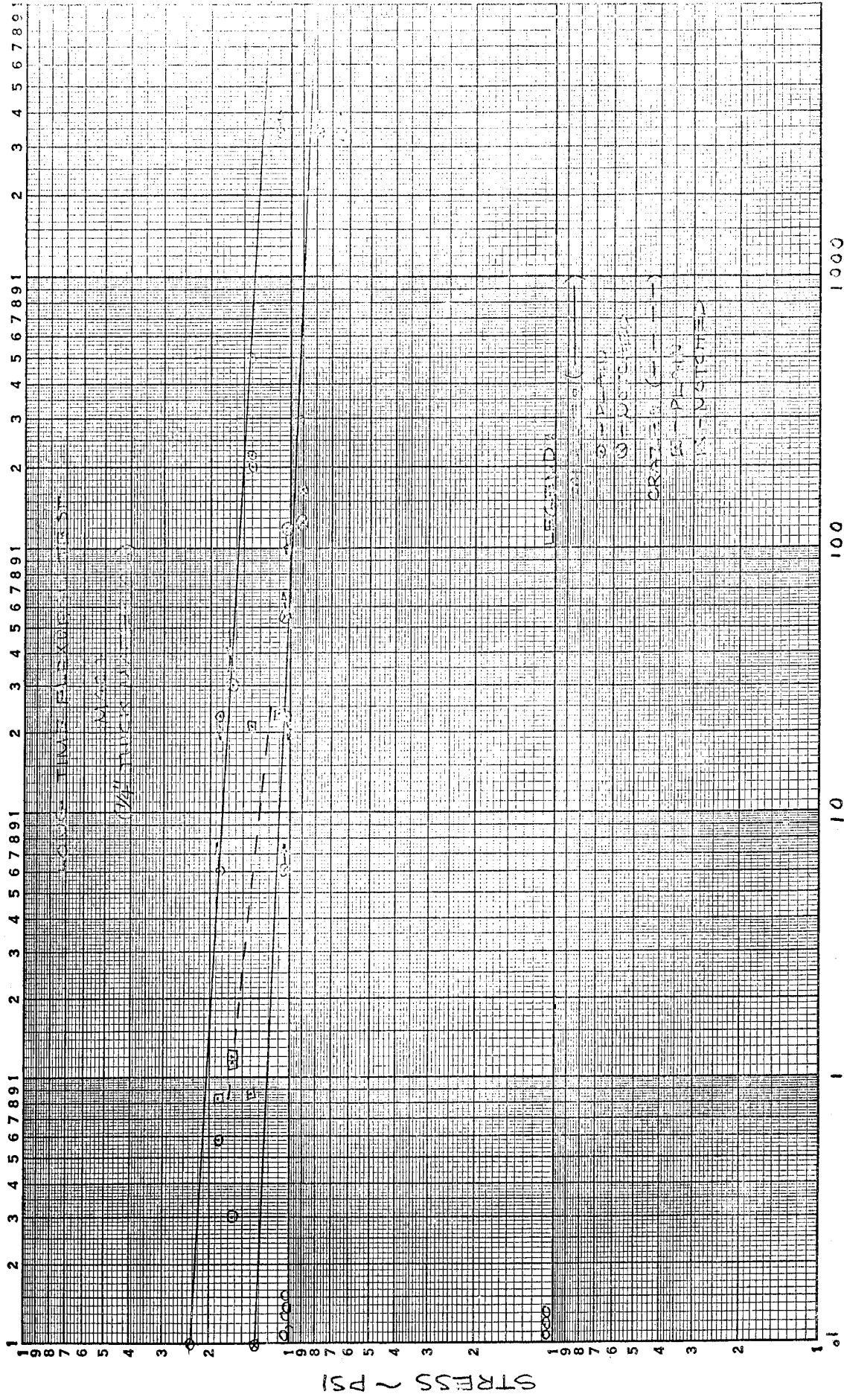

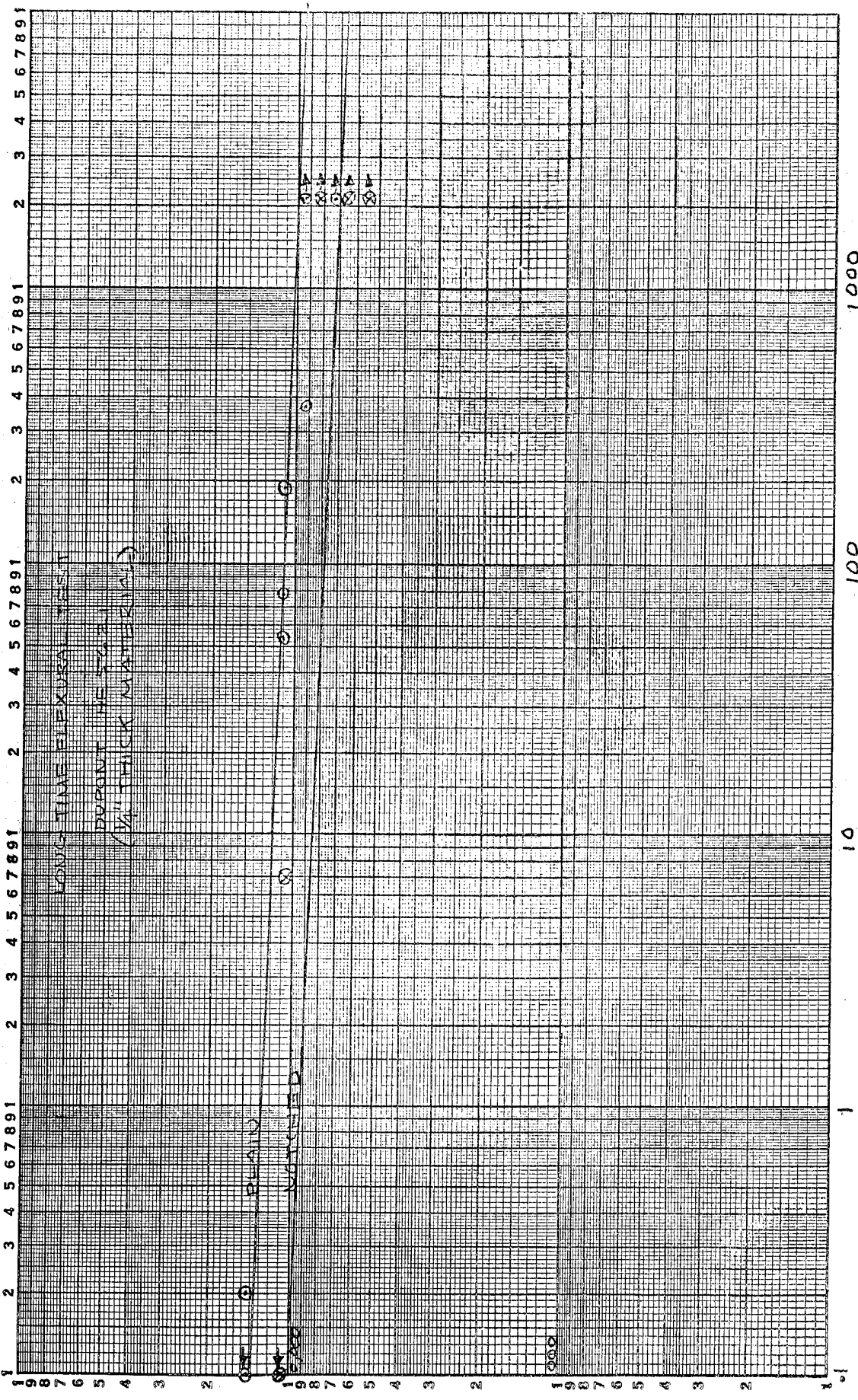

STRESS ~ PSI

CRAZE RESISTANCE

MATERIAL	SOLVENT	STRESS	DATA (1)		RESULTS - SECONDS			
			SOURCE	NO.	MAXIMUM	MINIMUM	AVERAGE	
Plex II	Toluene	1000	Nor.	1	5 minutes - No craze			
		2000	Nor.	2		(2)	300 (3)	
		2000	L.	2			240	
		2000	D	-	5 minutes - No craze			
		3000	L	2			60	
		4000	L		Immediate			
	Isopropyl Alcohol	1000	L	2	1 hour - No craze			
		1000	Nor.	1	5 minutes - No craze			
		2000	L	2			1800	
		2000	D	-	5 minutes - No craze			
		2000	Nor.	3			276 (2)	
		3000	L	2			420	
	MEK	Acetone	4000	L	2	120 immediate		
			500	Nor.	1	5 minutes - No craze		
			1000	Nor.	1			13
			2000	Nor.	2		(4)	30
			500	L	1	5 minutes - No craze		
			1000	L	2	180	120	150
	Lacquer Thinner	1500	L	1			60	
		2000	L	2			Immediate	
1000		L	2			1500		
2000		L	2			60		
3000		L	2			Immediate		
Ethylene Glycol		2000	L	1	1 hour - No craze			
	4000	L	1			1500		
	Propylene Glycol	2000	L	1	1 hour - No craze			
		4000	L	-			600	
5105XP	Toluene	1000	L	2	1 hour - No craze			
		2000	L	2			1800	
		3500	D	-	5 minutes - No craze			
		4000	Nor.	1	5 minutes - No craze			
		4000	L	2			90	
		4500	Nor.	3		(2)	300	
	Isopropyl Alcohol	1000	L	2	1 hour - No craze			
		2000	L	2			1380	
		3000	L	2			720	
		3000	Nor.	1	5 minutes - No craze			
		3500	D	-	5 minutes - No craze			
		4000	L		Immediate			
	MEK	Acetone	4000	Nor.	2	288	150	219
			1000	Nor.	1	5 minutes - No craze		
			1500	Nor.	1	5 minutes - No craze		
			2000	Nor.	3	300	120	196
			1000	L	2			270
			2000	L	2			120
	Acetone	4000	L	2			Immediate	

CRAZE RESISTANCE (Continued)

MATERIAL	SOLVENT	STRESS	DATA (1)		RESULTS - SECONDS			
			SOURCE	NO.	MAXIMUM	MINIMUM	AVERAGE	
5105XP	Lacquer Thinner	1000	L	2	1 hour - No craze			
		2000	L	2			900	
		3000	L	2			120	
		4000	L				Immediate	
Sierracin 611	Toluene	-	D	-	5 minutes - No craze			
	Toluene	15000	L	1	10 minutes - No craze			
	Isopropyl Alcohol	4000	L	1	1 hour - No craze			
		16000	L	1	10 minutes - No craze			
		-	D	-	5 minutes - No craze			
	Acetone	12000	L	1			2200	
		13000	L	1			1200	
		14000	L	1			600	
	Ethylene Glycol	4000	L	1	1 hour - No craze			
	Propylene "	4000	L	1	1 hour - No craze			
	1% NaOH	8000	L	1	10 minutes - No craze			
		10000	L	1	10 minutes - No craze			
	Butyl Lactate	8000	L	1	10 minutes - No craze			
		10000	L	1			600 (8)	
	14000	L	2	720 (8)	300 (8)	510 (8)		
MACA	Toluene	4000	Nor.	1	5 minutes - No craze (5)			
		5000	Nor.	1	5 minutes - No craze (5)			
		6000	Nor.	1	5 minutes - No craze (5)			
		6000	D	-	5 minutes - No craze (5)			
		7000	Nor.	1	5 minutes - No craze (5)			
		7000	Nor.	1	5 minutes - No craze (6)			
		7500	Nor.	2	300	294	297 (6)(2)	
		8000	Nor.	1	5 minutes - No craze (5)			
		9000	Nor.	1	5 minutes (3) (5)			
		10000	Nor.	1			216 (5)	
		Isopropyl Alcohol	4500	Nor.	1	5 minutes - No craze (5)		
			5000	Nor.	1	5 minutes - No craze (5)		
			6000	Nor.	1	5 minutes - No craze (5)		
			6000	D	-	5 minutes - No craze (5)		
			7000	Nor.	1	5 minutes - No craze (5)		
			8000	Nor.	1	5 minutes - No craze (5)		
	9000		Nor.	1	5 minutes - No craze (5)			
	MEK	9000	Nor.	3	300	180	260 (6)(7)	
		9500	Nor.	1			234 (6)	
		10000	Nor.	2		(2)	300 (5)	
		3000	Nor.	1	5 minutes - No craze (5)			
		4000	Nor.	1	5 minutes - No craze (5)			
		4000	Nor.	1	5 minutes - No craze (6)			
4500		Nor.	1	5 minutes - No craze (6)				
5000	Nor.	2	300	174	237 (5)			
5000	Nor.	2	126	120	123 (6)			

(Continued)

CRAZE RESISTANCE

DATA SOURCE: NORTHROP

<u>MATERIAL</u>	<u>SOLVENT</u>	<u>STRESS</u>	<u>NO. SPEC.</u>	<u>RESULTS - SECONDS</u>		
				<u>MAXIMUM</u>	<u>MINIMUM</u>	<u>AVERAGE</u>
Polymer K	Toluene	5000	2	64,802	61,226	63,014
		7000	3	3,605	7,212	4,810
		9000	3	2,475	2,245	2,363
		10000	3	1,704	1,488	1,595
		11000	3	963	653	769
	Isopropyl Alcohol	10000	3	1,576	1,052	1,244
		12000	3	520	472	498
		14000	3	Broke when preloaded		
	MEK	3000	3	82,320	27,300	59,400
		4000	3	6,900	3,240	4,780
		4500	3	283	200	239
		5000	3	203	140	178
		6000	3	112	83	102
	HE5621	Toluene	4500	3	10,852	10,839
5000			3	10,860	10,080	10,480
6000			3	1,101	1,099	1,100
7000			3	103	100	102
9000			2	24	23(9)	24
9500			3	15	12	13
Isopropyl Alcohol		4500	3	2,110	1,994	2,064
		5000	3	1,573	1,510	1,535
		6000	3	331	329	330
		7000	3	139	138	139
		9000	3	79	77	78
MEK		10000	3	38	36	37
		10500	3	11	9	10
		3000	3	249	233	242
		4000	3	151	127	139
		4500	3	94	81	86
		5000	3	59	57	58
		6000	3	19	17	18
6500	3	6	5	6		

- (1) All Lockheed crazing data was recorded to the nearest minute and obtained per LAC Specification 1-848.
- (2) Light Craze
- (3) One specimen did not craze until load was momentarily reapplied.
- (4) Pronounced Craze
- (5) Sheet "A"
- (6) Sheet "B"
- (7) One specimen did not craze
- (8) Specimen failed
- (9) One specimen failed on preload

FORMING

Source of Data: Douglas Aircraft Company

6" Diameter Hemispherical Shape.
Using Air-pressure Fixture.

	Temperature, °F.				
<u>3" Depth Draw</u>	275	300	325	350	375
	Air-Pressure, P.S.I.				
Plexiglas II Thickness, In.	30 (.271)	20 (.235)	18 (.276)	17 (.266)	15 (.278)
MACA Thickness, In.	-	-	20 (.231)	18 (.263)	10 (.232)
Plexiglas 5105 Thickness, In.	-	26 (.254)	19 (.231)	19 (.231)	18 (.231)

Various Draw Depths
at 275°F

Plexiglas 5105	.254" Thickness	1-1/2" Draw	20 P.S.I.
	.254" "	2" Draw	30 P.S.I.
	.254" "	2-5/8" Draw	32 P.S.I.
	.244" "	2-3/4" Draw	36 P.S.I.
Sierracin 611	.251" "	1/2" Draw	22 P.S.I.
	.253" "	1/2" Draw	24 P.S.I.

- Note 1. -Marks indicate conditions under which the sheet tested was obviously too rigid.
2. MACA - Methylalpha-Chloro-Acrylate.
 3. Sierracin 611 = Selectron 44.
 4. Sierracin 611 sheets broke at 275°F:
 - a. Three, under 10 to 40 P.S.I. air-pressure.
 - b. Two, using male plug and manual load application.

Results of Cementing Tests of Transparent Plastics

Source: Convair - San Diego

Specimen:

Compression shear type specimens consisted of two milled strips of transparent material 1" x 8" x .250" overlapped in bonding by 3/4 inch to form bonded pads 1-1/4" x 8" which were cut into test specimens 1 inch wide.

Bonding Procedure

Plexiglas II was prepared by masking with cellophane tape and dipping one milled strip in ethylene dichloride for 17 minutes. The masking tape was removed and the soaked strip was placed in position over the unsoaked strip with a 3/4" overlap. The two joint halves were then bonded 30 hours with a pressure of 5 psi.

Sierracin, 5105 XP, and Gafite bonds were all prepared with Epon Adhesive VI. Faying surfaces were cleaned thoroughly with Fullercol (Denatured Ethyl Alcohol). The adhesive was then applied to both bonding surfaces and the strips were placed in position with contact pressure only, (approximately 1-2 psi). All specimens were allowed to cure at room temperature for 24 hours.

Annealing Procedure

Specimens were annealed as follows prior to test:

Plexiglas II	120° + 2°F for 20 hours
Sierracin 611	175° + 2°F for 20 hours
Rohm & Haas 5105 XP	190° + 2°F for 20 hours
General Analine Gafite (MACA)	250° + 2°F for 20 hours

Conditioning Specimens

All specimens were conditioned prior to test for 96 hours at 77°F ± 2°F and 50 ± 5% relative humidity.

Results

Results in terms of pounds per sq. in. in compressive shear are tabulated below.

<u>Spec. No.</u>	<u>Plexiglas II</u>	<u>5105 XP</u>	<u>Sierracin 611</u>	<u>Gafite (MACA)</u>
1	3390	4800	3420	3990
2	3570	5150	4395	3700

Results (Continued)

<u>Spec. No.</u>	<u>Plexiglas II</u>	<u>5105 XP</u>	<u>Sierracin 611</u>	<u>Gafite (MACA)</u>
3	3300	4250	4150	3500
4	3395	4780	4800	5210
5	3930	5100	5520	4450
6	3280	4950	4060	5255
7				4600
Average	3478	4838	4391	4386