

Technical Report

R 778

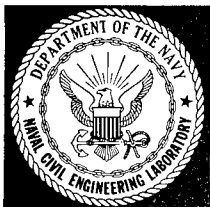

Sponsored by

NAVAL FACILITIES ENGINEERING COMMAND

November 1972

NAVAL CIVIL ENGINEERING LABORATORY

Port Hueneme, California 93043

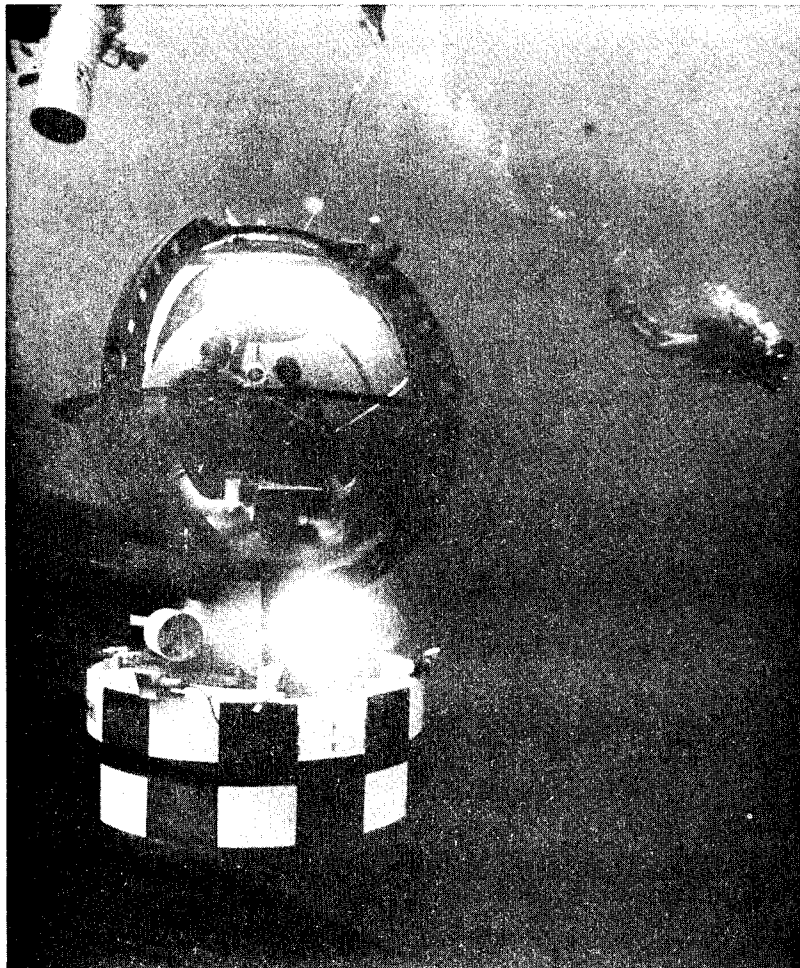

OPERATIONAL EVALUATION OF NEMO,
AN ACRYLIC-HULLED SUBMERSIBLE

Approved for public release; distribution unlimited.

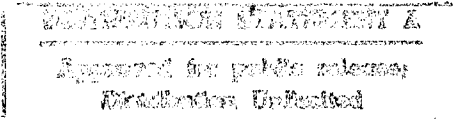

19960425 068

THIS QUALITY INSURED 2

PLASTIC 18241

OPERATIONAL EVALUATION OF NEMO, AN ACRYLIC-HULLED SUBMERSIBLE

Technical Report R-778

YF 38.535.005.01.006

by

P. K. Rockwell and H. J. Migliore

ABSTRACT

The Naval Civil Engineering Laboratory has conducted an operational evaluation of NEMO (Naval Experimental Manned Observatory), an acrylic-hulled submersible. The objectives of the program were to determine the benefits of the panoramic visibility afforded by the transparent acrylic plastic hull, to evaluate the overall design and modes of operation of NEMO, and to judge the potential application of NEMO-type vehicles to the Navy's oceanographic and ocean engineering needs. It is concluded that (1) visibility through the hull is free from shape distortion, making NEMO an excellent observation platform, (2) objects look smaller and closer than actual, (3) operator comfort is good, (4) design of the vehicle is basically sound, simple, and reliable, (5) vehicle operation has been demonstrated to be safe, and (6) NEMO's versatility and usefulness are hampered by the lack of a true hovering/flying capability. It is recommended that future transparent-hulled vehicles have more mobility than NEMO and that a manipulation arm be added.

Approved for public release; distribution unlimited.

CONTENTS

	page
INTRODUCTION	1
OPERATIONAL EVALUATION	1
Visibility and Personnel Comfort	2
Maneuverability	6
DESIGN CONSIDERATIONS	9
Battery Pack	9
Winch System	11
Ballast System	12
Safety Systems	13
Personnel Comfort	14
CONCLUSIONS	15
RECOMMENDATIONS	16
ACKNOWLEDGMENTS	16
REFERENCES	16

INTRODUCTION

The Naval Civil Engineering Laboratory in 1965 became involved in a research and development program with the overall objective to design, fabricate, test, and evaluate a pressure-resistant submersible hull with panoramic visibility capable of operating to 600-foot depths. A transparent acrylic plastic pressure hull was developed¹ and the design was verified analytically and experimentally.²⁻⁶ The end product of this research and development program was the research submersible NEMO (Naval Experimental Manned Observatory), which was christened in May 1970 (Figure 1). A full system description of NEMO is presented in Reference 7. The purpose of this report is to present the results of the operational and design evaluation of NEMO performed by NCEL.

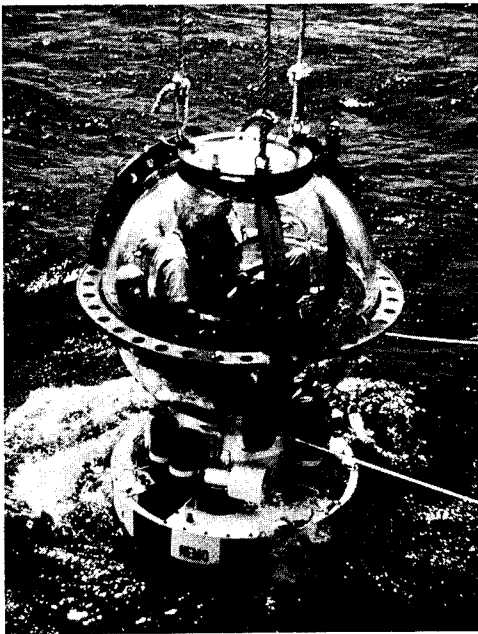

Figure 1. NEMO (Naval Experimental Manned Observatory).

OPERATIONAL EVALUATION

The objectives of this evaluation, conducted during the period May 1970 through February 1972, were:

1. To use NEMO under various circumstances to ascertain under what conditions panoramic visibility is clearly superior to partial visibility (that is, as provided by multiple viewports).
2. To evaluate NEMO's design and modes of operation for reliability, safety, and potential application of NEMO-type vehicles to the Navy's oceanographic and ocean engineering needs.

Visibility and Personnel Comfort

Visibility from any submersible is a function of the hull characteristics, the design configuration of the submersible, and the internal environment. Personnel comfort affects the ability of the observer to effectively use the visibility provided. The factors affecting visibility and personnel comfort as they relate to NEMO are discussed in the following sections.

Hull Characteristics. The basic advantage of acrylic hulls is that they permit omnidirectional viewing. Conventional metal hulls depend on a number of viewports, resulting in restricted views in preselected directions. Also, viewports distort the view. Distortion was considered a potential problem for acrylic plastic hulls. However, Trowbridge⁸ analyzed the optical characteristics of viewing through the NEMO sphere and concluded that objects should look smaller and closer than they really are but that no shape distortion should be discernible.

All 89 dives performed with NEMO have served to help evaluate the visual characteristics of the acrylic hull. In December 1970 and January 1971, a formal visibility study was conducted to quantify the heretofore qualitative observations.

An experiment was designed by the Naval Personnel and Training Research Laboratory (NPTRL) to determine empirical relationships between perceived and actual size and distance of circular targets.⁹ Ten circular targets fixed to stakes were driven into the sediment in 50 feet of water near Anacapa Island (Figure 2). A large iron clump was placed at the focal point of the array and NEMO's anchor cable was attached to the clump. This provided a known reference point to which NEMO could descend repeatedly to standardize the data taken during the experiment. Subjects were instructed to estimate the size of the discs, the distance between NEMO and the discs, and to read an eye chart placed at the center of the array. The subjects ranged from experienced NEMO operators who also had scuba diving experience, to neophytes who had never been underwater, either in a submersible or by diving. The significant results of this study are:

1. The experimental results corresponded well with the theory of Reference 8; that is, subjects tended to underestimate both size and distance.
2. The experience level resulted in significantly different estimations. Experienced NEMO operators estimated accurately the size and distance, whereas subjects who had never been underwater significantly underestimated size and distance.
3. All subjects agreed that the shapes of objects and underwater life appeared to be normal.

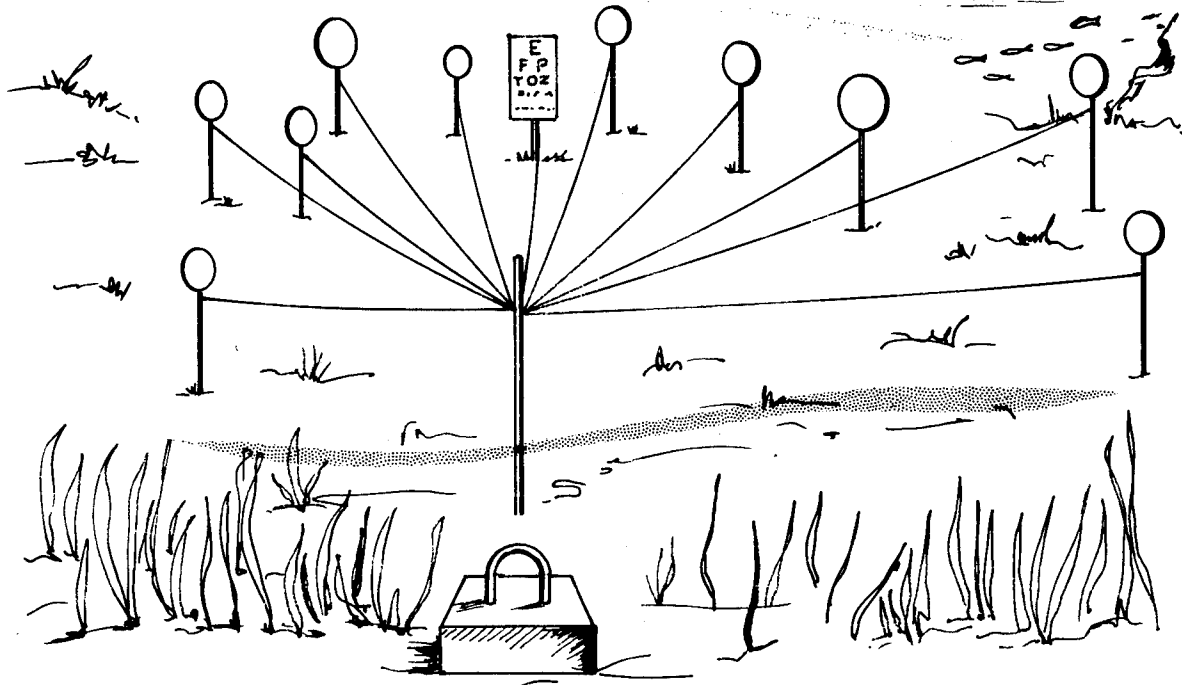

Figure 2. Visibility array.

It is interesting to point out the rapid acclimation of the two experienced subjects to the size and distance discrepancies noted above. With fewer than 20 hours in NEMO, both operators unknowingly had adjusted their perception to account for the optical characteristics of the hull. A novice observer could probably adjust even more rapidly if instructed by an experienced operator to compensate for the discrepancies.

Design Configuration. Since the primary purpose of using an acrylic hull is to provide excellent viewing, the NEMO system was designed to present a maximum unobstructed view to its occupants (Figure 1). The lower unit, which consists of the service module, battery, ballast tanks, and winch system, is smaller in diameter than the hull. The operator can easily see the bottom as he approaches it. The only obstruction to viewing is the structural cage assembly. These members are slender and positioned so that the operator has a 120-degree unobstructed field of vision directly in front of him. Equally important, the section joints do not significantly affect the view (Figure 3).



Figure 3. View from NEMO at 40-foot depth.

The ability of NEMO to rotate, as provided by the hydraulic propulsion motors, allows the operator to position NEMO so that the viewed object is directly in front of the submersible. During the January 1971 cruise, the excellent visibility provided by the transparent hull was found helpful during short near-bottom horizontal excursions through a kelp bed.

NEMO's upward visibility allows the operator to ensure that the surface is clear of craft, kelp, and other obstructions before breaking the surface. He is also able to see when the towline, tag lines, and lifting lines are being attached, so he is in close contact with the launch and retrieval operations as well as with underwater operations.

Environment/Atmosphere Control. Internal environment affects visibility, since the humidity is usually high and moisture condenses in the hull. Also, extreme temperatures can make long-duration missions uncomfortable. In a conventional submersible the observer can simply wipe the viewport, but in NEMO the whole inside surface of the hull must be wiped clean. Design modifications have reduced the fogging problem to a minimum. That is, fogging occurs only when NEMO must spend long periods of time at the surface. The

sun produces a greenhouse effect (trapping infrared radiation), which results in increased temperature and humidity. The normal operational procedures for NEMO minimize the amount of time spent at the surface, and thus minimize fogging. While NEMO is submerged, the humidity control system reduces fogging of the hull walls.

During the builder's trials in the Bahama Islands, the NEMO atmosphere reached uncomfortably high temperatures and humidity. The causes of the high internal temperature were:

1. Long periods of time spent at the surface in direct sunlight
2. Poor heat-conduction properties of acrylic
3. Warm (80°F) water temperature
4. Heat generated by the occupants, internal electronics, and chemical reaction of the CO₂ scrubbing compound (Baralyme)

The high humidity resulted from:

1. High humidity of the air at the outset (85%)
2. Insufficient water absorption by NEMO's passive silica gel bags
3. Perspiration and respiration of the occupants

The high humidity caused fogging of the interior surfaces of the sphere, which degraded the visibility.

Several solutions to the temperature and humidity problem have been tried. The system now in use consists of the following:

1. An active silica gel bed located in the top 3 inches of the scrubber blower canister
2. Closed cans of ice placed near the scrubber blower outlet to condense moisture not removed by the active silica gel bed
3. A small fan directed over the personnel hatch, which is the only good heat-transfer surface in the NEMO hull
4. A drip ring located beneath the hatch to catch water condensed on the hatch
5. Preconditioning the air inside NEMO between dives to bring the air to ambient temperature and humidity (This is accomplished with a blower.)

Several experiments were conducted in the laboratory to evaluate the above changes. Laboratory and at-sea conditions differed only in that the laboratory tests were conducted in air (a worst-case condition, since the heat-conduction properties of the hatch/water interface is part of the cooling

system). Both in the laboratory and during subsequent cruises, the present methods showed marked improvement over the original humidity/temperature control system.

Nonetheless, the NEMO atmosphere control system could be further improved. Specifically, methods are needed to protect the hull from direct sunlight while on the surface and to more effectively remove moisture from the internal atmosphere.

Seating. The most frequent complaint regarding conventional submersibles is that the observer must assume uncomfortable positions to use the viewports. In NEMO, the seating position of the operator and observer (Figure 4) is very comfortable. The personnel can see up, down, and to the sides with a simple head motion, and rotation of NEMO provides viewing in all directions. Even though the seat location is not in the exact center of the sphere, occupants can look through the hull at any angle without experiencing distortion. The erect seating position is ideal for data taking, and the seat design is comfortable for long-duration dives. The only objection to the interior arrangement is the lack of storage space. This drawback does not significantly reduce the comfort of the crew but does cause inconvenience and wasted time in gaining access to some items.

Maneuverability

NEMO can be maneuvered in three modes: vertical winching, translation, and rotation.

Vertical Winching. NEMO as an observation platform emphasizes vertical mobility as provided by a self-contained winch system.* Normally, NEMO lowers its anchor, vents the ballast tanks, and winches down the anchor line. Several advantages of NEMO's vertical mode of operation are:

1. Sophisticated propulsion systems and hydrodynamic design are eliminated, making the system less costly and more reliable.
2. Recovery is simplified since the location is well defined and does not change appreciably.
3. No buoyancy, propulsion, or trim controls are needed to station-keep.
4. NEMO without its anchor is always positively buoyant, so a simple provision for cutting the anchor cable provides a large degree of safety.

* NEMO's usefulness is limited to observation in its present configuration. The addition of a manipulator arm would enhance its ability.

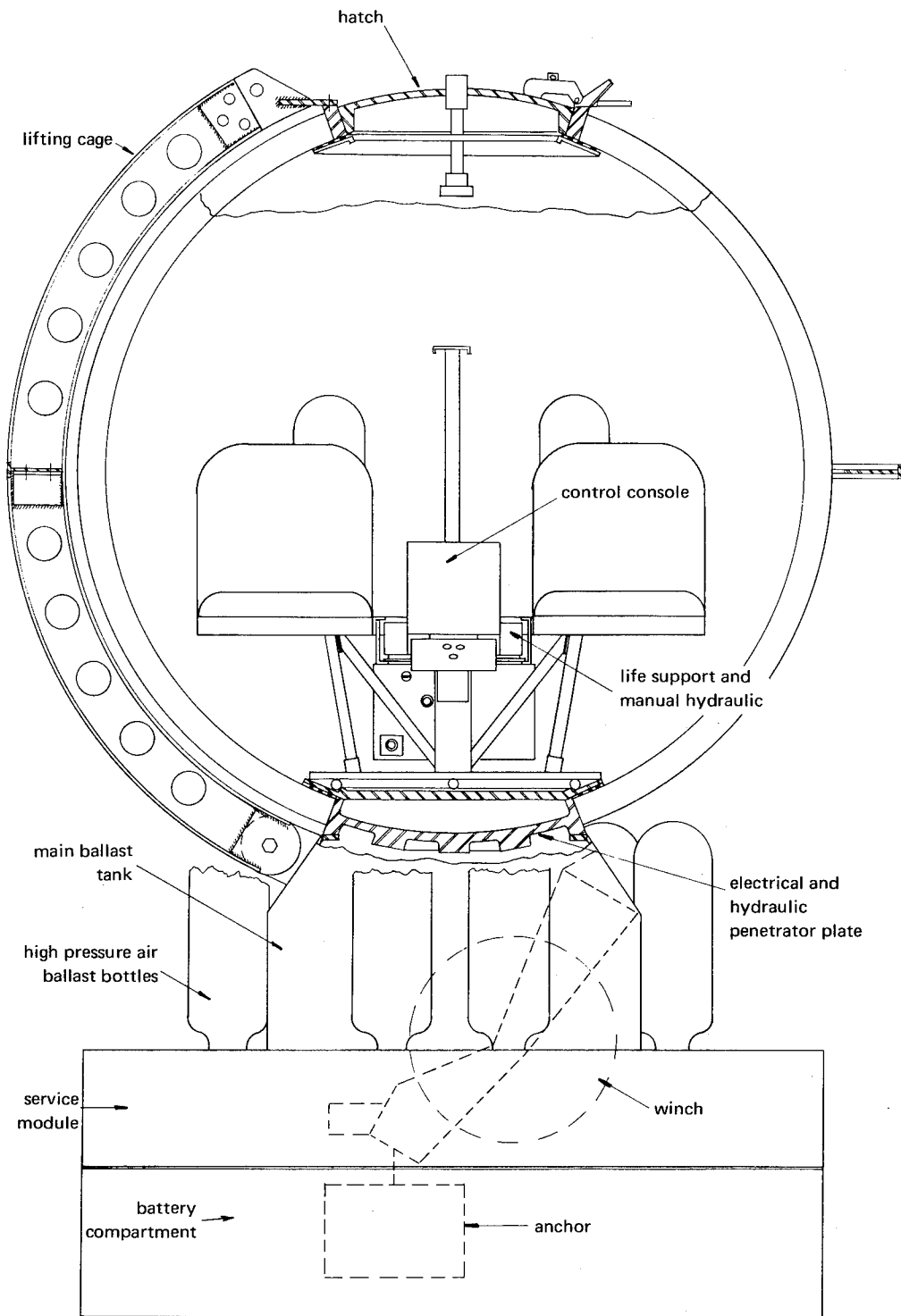

Figure 4. Schematic of NEMO system.

Some disadvantages of vertical mobility as a primary mode of operation are also readily seen.

1. NEMO cannot function effectively as a search and inspection platform; this limits the usefulness of its primary advantage—good visibility.
2. If the translation capability is not available, NEMO must surface to reposition itself with respect to the object under study.
3. Dropping the anchor from the surface may result in damaging the object under study, since positioning the anchor contains some error.
4. Winch-controlled ascents and descents consume more power than buoyancy-controlled ascents and descents do.

The anchor/winch system design is such that when the winch is started during descent, the anchor lifts off the bottom. This results in lateral motion of NEMO if currents are present, and at the very least causes the bottom sediment to be disturbed, reducing visibility. For example, during the SEACON* inspection dive, the anchor was accurately placed 12 feet from the viewport end of the SEACON structure. Six stops were made during descent, and when NEMO reached the bottom it was about 40 feet away from the structure.

Furthermore, whenever the winch is stopped during descent, NEMO coasts past the stop point, and on many occasions has contacted the bottom, stirring up the sediment and damaging the winch protection cage.

Translation. During the visibility dives of December and January, accurate bottom positioning was required to standardize the visual judgments from dive to dive. To place NEMO in the intended spot on the ocean floor, the anchor line was shackled to a prepositioned clump. Obviously, this method is not feasible for other than diver-depth operations. Thus, a translation capability is desirable for accurate positioning. NEMO can translate short distances by using the ballast system to achieve neutral buoyancy, then moving with the rotation motors.

Early in the evaluation program it was discovered that (as predicted) buoyancy control for translation was difficult. With open ballast tanks, changes in depth result in volume changes of the air in the tank, altering the buoyancy of NEMO. For some of the shallow dives, the gas expansion as NEMO lifted off the bottom resulted in several unplanned ascents, since the rate that air could be vented from the tanks could not "catch up" with the rate at which the air expanded. This operational problem led to the design of the semihard ballast tank discussed in the recommendations section.

* NCE L Seafloor Construction experiment.

Rotation. NEMO's capability of rotating about its vertical axis has proved useful. During the July sea trials, NEMO descended alongside a rock outcrop which was behind the passengers. By rotating NEMO, a close examination of the sea life attached to the rocks was made possible. During the December and January visibility studies, the current and surge on the bottom tended to rotate NEMO away from the visual array. By using the rotation motors, NEMO was held in the correct orientation while data were being taken. Finally, during the January cruise, it was desired to translate out of a kelp bed. By rotating NEMO, a clear path was chosen, and NEMO translated about 50 feet out of the kelp bed.

DESIGN CONSIDERATIONS

In addition to evaluation of NEMO from a mission-oriented standpoint (that is, as a control and observation center), the subsystems were evaluated. The emphasis here was on the component and subsystem adequacy, taking into account NEMO's expected performance characteristics. Changes made to the as-delivered system are documented, and specific recommendations are made where appropriate for subsystem modifications.

Battery Pack

During the builder's trials in the Bahamas and at Anacapa Island, one acrylic battery cover cracked. The battery compensator, which is a rolled-diaphragm piston-type compensator, was suspect. The pressure differential needed to move the compensator piston was measured to determine whether the compensator was working correctly. It was found that a 1-psi differential was needed to compensate, but a 3- to 4-psi differential was needed to reset the compensator. Since the battery pack is equipped with 1.5-psi pop-off valves to allow hydrogen gas expulsion, mineral oil was escaping through the pop-off valves instead of resetting the compensator. The compensator was disassembled, serviced, reassembled, and retested. The operational differential pressures were both about 1 psi, but the reset time for the compensator was about 10 seconds. During the January cruise, NEMO was winched to the surface in 5-foot increments with 30-second stops every 5 feet to determine whether the compensator would reset. The compensator did not reset, and apparently was deficient in two ways: (1) The compensator volume (about 1 gallon) was inadequate to compensate for oil compression, gassing, and trapped air in the battery pack. (The design of the battery pack does not allow expulsion of all trapped air before a dive.) (2) The reaction time was

so slow that pressure built up in the pack on ascent, causing oil to escape through the relief valves instead of resetting the compensator. A 5-gallon bladder-type compensator system (Figure 5) has replaced the original compensator. This change has eliminated the compensation problem.

Recommendation. The existing battery pack covers are flat plates of acrylic plastic with a domed region leading to the battery pack vent lines. In theory, all the gas in the battery pack should migrate to those domed regions and be vented out. In practice, however, gas pockets remain at other regions under the flat plates and are never vented. This problem can be eliminated by replacing the present cover with a sloping surface design, where the high point would connect with the vent line. This design would ensure that all entrapped gasses are eliminated both before and during a dive. Thus, the compensator would only have to make up for fluid compression, there would be less fluid lost during ascent, and the possibility of hydrogen gas buildup would be reduced.

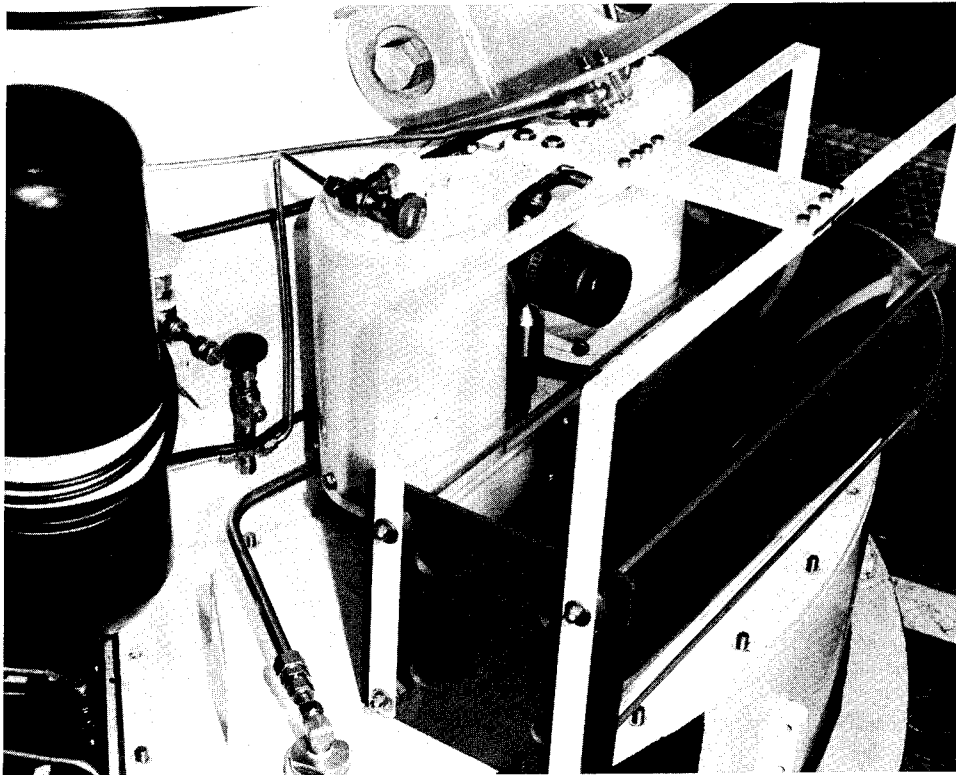

Figure 5. Compensator and ABT (auxiliary ballast tank) flood valve.

Winch System

Several problems involving the winch system were encountered. When NCEL received NEMO after the July sea trials, the winch barrel gear teeth and pawl mounting shaft were bent and the cable guide/pawl follower mechanism was loose. Upon repairing and installing the level wind mechanism, it was discovered that the cable guide mechanism could strike the barrel gear housing, preventing the pawl from returning on the barrel gear, and thus bending the barrel gear teeth. Also, the barrel gear bearings and spacer were being pushed out of position. A bearing retainer was added and the spacers were sized to allow the pawl follower to return correctly. During the December cruise, the anchor cable chafed against the leading edges of the cable guide, causing the cable to fray and unlay. In one instance, enough cable had unlayed to stall the winch during descent, and NEMO had to return to the surface. Teflon guides were fabricated to lead the cable smoothly into the cable guide. During the January cruise, these guides prevented the cable from chafing, and with the other improvements, winching operations proceeded smoothly.

Vibration and side loads caused the cable guide/pawl follower connection to loosen periodically. The entire assembly had to be removed to permit tightening. This problem was alleviated by welding a plate to the pawl follower and through-bolting this assembly to the cable guide assembly. Three benefits resulted:

1. The bolts are larger, and can be torqued down tighter than before. Also, lock washers were included.
2. By moving the cable guide mechanism away from the barrel gear, the angle of attack of the anchor cable is reduced, thus reducing the chafing action mentioned above.
3. Should the mechanism loosen, the bolts can be reached easily and tightened in a matter of minutes.

This design change has effectively eliminated the winch problems.

Recommendation. Presently, the winch control system consists of three functions: on/off, reel-in/reel-out, and fast/slow. All functions are go/no-go in nature, with no provision for fine control. As a result, the anchor lifts off the bottom during start-up, and NEMO coasts past the intended stop point. To eliminate these problems, it is recommended that the winch system have a variable rate control, thus allowing controlled acceleration and deceleration.

Ballast System

In the normal winching mode, the ballast system is used only once (flooding at the surface to submerge) and would be blown only in an emergency to overcome the weight of the anchor if the winch should fail. However, NEMO's rotation motors allow translation, and very delicate control of the ballast system is required during this operation. The simplest way to achieve neutral buoyancy for translation is to blow the auxiliary ballast tank (ABT) first then put a small amount of air in the main ballast tank (MBT). As NEMO lifts off the bottom, the air expands since the ballast tanks are open to seawater. Therefore, it is necessary to continually adjust the air volume in the tanks to avoid surfacing or settling back on the bottom. One of the problems encountered is that the position of the solenoid valve in the ABT requires starting a siphon to let air out. Since the tank is at ambient pressure, the siphon cannot be started and air cannot be vented from the tank. To correct this situation, the solenoid valve was placed atop the ABT, with the air inlet to the valve going uphill (Figure 5). This modification has resulted in quicker and more reliable response to flooding the ABT, improving the neutral buoyancy control.

Recommendation. The NEMO ballast tanks cannot be easily controlled in shallow water since both tanks are open to seawater. This phenomenon can be controlled by the operator at deeper depths, since the rate of air expansion is much slower than at shallow depths. The modification of NEMO's auxiliary ballast tank from an "open" to a "semihard" or pressure-compensated ballast tank would effectively eliminate this control problem. A semihard ballast tank (Figure 6) is an ambient-pressure ballast tank, closed to seawater by valves, with an automatic control system (regulator and relief valve) which maintains a constant volume of air in the tank even though NEMO changes depth. The regulator/relief valve system senses change in ambient pressure, and lets in water or adds air as needed to maintain constant air volume. In other words, once the operator has put the correct amount of air in the ballast tank to achieve neutral buoyancy, the buoyancy does not change with depth unless the operator changes it. The addition of a semihard ballast tank should make neutral buoyancy easier to achieve, resulting in increased safety, greater translation ability, less ballast air consumption, and fewer operator-controlled changes.

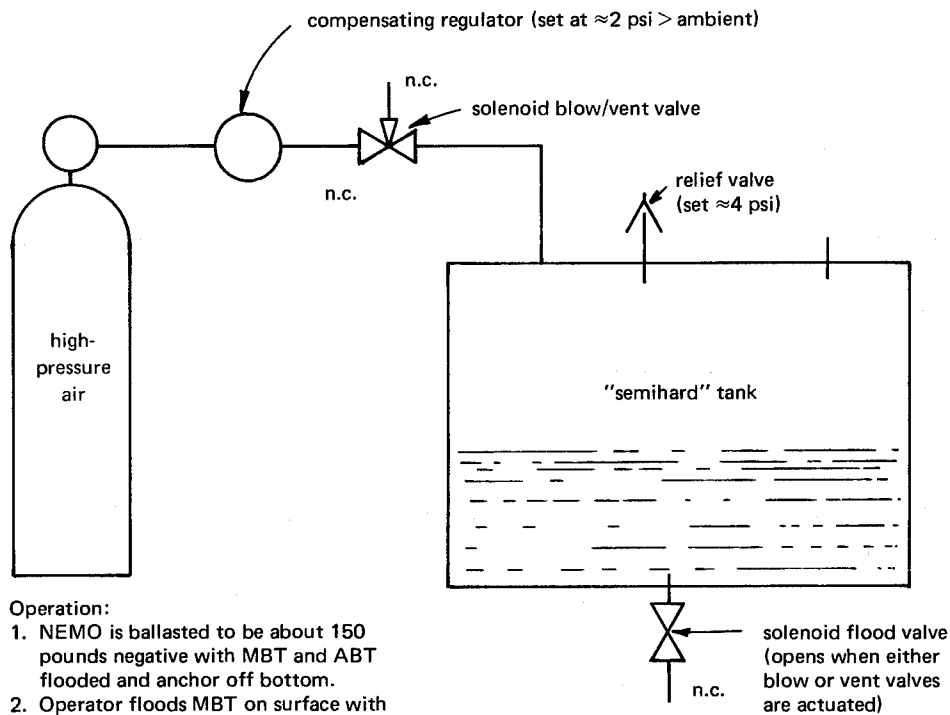

Operation:

1. NEMO is ballasted to be about 150 pounds negative with MBT and ABT flooded and anchor off bottom.
2. Operator floods MBT on surface with semihard ballast tank dry until NEMO about 25 pounds positive.
3. Operator vents semihard ballast tank to achieve descent.
4. Operator controls descent by regulating water volume in semihard ballast tank.
5. Pressure regulator feeds gas into semihard ballast tank as NEMO descends to prevent collapse.
6. Relief valve vents gas from semihard ballast tank during ascent to prevent explosion.

Figure 6. Schematic of semihard ballast tank.

Safety Systems

Currently, NEMO can return to the surface by employing one of six different methods.

1. Winch to the surface (normal).
2. Free ascend (normal) by blowing ballast.
3. Freewheel the winch (emergency).
 - a. Hydraulic system on, winch motor off, and winch lock off.
 - b. Hydraulic system off, winch motor in "run" position and winch lock in "off" position.
 - c. Electrical power failure.

4. Cut the anchor cable with the manual hydraulic system (emergency).
5. Cut the anchor cable with the explosive cutter (emergency).
6. Drop the battery pack by cutting the main power cable (explosively) and releasing the battery pack with the manual hydraulic system.

However, considerable attention has been given to locating NEMO if it is stuck on the bottom with no immediate danger to the occupants. Two drawbacks are apparent if NEMO must employ emergency methods to surface:

1. Expensive equipment may be lost (the battery pack).
2. NEMO may surface uncontrollably, thus creating the potential hazard of striking something at the surface.

It is considered desirable to be able to positively locate NEMO at the bottom so that:

1. The surface support would know that NEMO was stuck but not in immediate danger.
2. Action could be taken to look at NEMO's condition and either correct the situation or aid in recovery.

For these reasons, an emergency float buoy has been installed on NEMO. The solenoid release mechanism is actuated from the control console, and the buoy travels to the surface paying out a buoyant shot line which remains attached to NEMO. Thus by use of scuba divers, hardhat divers, or a submersible, NEMO could be aided or recovered more efficiently and safely than without the emergency buoy.

Personnel Comfort

Humidity/Temperature Control Recommendations. The humidity inside the NEMO hull is controlled by desiccant (silica gel) and by cold condensing surfaces (in the form of cans of frozen water). The temperature, also, is controlled by these cans of ice. Both the humidity and temperature have been maintained adequately. However, if the NEMO hull is exposed to the sun for a period of time the internal temperature rises uncontrollably. A more effective humidity/temperature control system is needed, such as a heat exchanger. The cooling medium for the exchange could be ambient seawater circulated by a small pump. Similar systems have proved to be effective for other submersibles, and result in a more comfortable, safer working environment. Also, fogging of the viewing surfaces would be reduced. While on the surface, the acrylic hull should be protected from direct sunlight by a cover.

Storage Space Recommendation. Many essential items, such as silica gel and Baralyme, must be stowed in back of or under the seats and around the occupants' feet. This practice results in wasted time and inconvenience when retrieving the items. The adoption of a heat exchanger would increase storage space by eliminating or reducing the number of cans of ice and the amount of silica gel. A more compact emergency rebreathing device would be advantageous. Redesigning the interior and taking advantage of component miniaturization could lead to more effective space use.

CONCLUSIONS

NEMO has made 89 dives to depths ranging from 25 to 612 feet to evaluate the system design and the usefulness of the acrylic-hull concept for manned submersible vehicles. Conclusions are:

1. Visibility through the hull is excellent.
 - a. There is no shape distortion.
 - b. Objects look smaller and closer than actual.
 - c. An excellent view of surroundings is afforded.
 - d. The panoramic visibility readily provides identification of potential hazards during surfacing, submerging, or translating.
 - e. The visibility allows the operator to observe directly the launch/recovery operations.
2. Personnel comfort is good.
 - a. The seating position allows comfortable viewing in all directions.
 - b. The humidity/temperature control provides a comfortable environment under most operational conditions.
3. Vehicle control is simple and reliable.
 - a. Rotation capability provides straight-on viewing of the surroundings.
 - b. Vertical mode of operation using the anchor/winch system enables no-power station keeping and allows checking overhead before surfacing.
 - c. Ballast control allows horizontal excursions using the rotation motors, but needs improvement.
4. Repair and maintenance are easy because of the simplicity of the design.
5. Operational safety has been well established.

RECOMMENDATIONS

NEMO has performed successfully. Nonetheless, several recommendations can be made which would improve the versatility and convenience of future transparent-hulled vehicles.

NEMO can maintain station at any depth to 600 feet with safety, reliability, and a minimum of power. Therefore, NEMO can be an effective and useful tool for the scientist who simply wants to descend in a preselected area and observe the surroundings. However, many dives with NEMO have demonstrated that the lack of a true hovering/flying ability hampers NEMO's versatility. With a more effective mobility feature, NEMO could descend to the bottom in a controlled fashion and translate to the desired position. Once in position, NEMO could use its present station-keeping mode for inspection or observation missions. This limited capability for translation could be effected by redesigning the thruster system and either adding a vertical thruster or providing better control of the ballast system.

Finally, the addition of a simple manipulator arm for sample retrieval and limited work capability would provide much more effective use of the excellent visibility provided by the acrylic plastic hull.

ACKNOWLEDGMENTS

NCEL's operational evaluation of NEMO was this laboratory's first experience in operating a manned submersible. The assistance provided by the Naval Ship Systems Command Material Certification Team, and Submarine Development Group 1 in certification and operation of NEMO is greatly appreciated. The operation, evaluation, and technical support were made possible by the contributions of LT Robert E. Elliott, CEC USN; LTJG Richard G. Luthy, CEC USNR; and Messrs. Gene A. Edgerton and John R. McKay of NCEL.

REFERENCES

1. Naval Civil Engineering Laboratory. Technical Report R-676: Development of a spherical acrylic plastic pressure hull for hydro-space application, by J. D. Stachiw. Port Hueneme, Calif., Apr. 1970. (AD 707363)
2. Southwest Research Institute. Final Report on Contract N00123-67-C-2123: NEMO stress analysis and material investigation, by R. C. DeHart, T. Wah, and L. R. Calcote. San Antonio, Tex., Mar. 1968.

3. Naval Civil Engineering Laboratory. Technical Note N-1113: The spherical acrylic pressure hull for hydrospace application, pt. 2. Experimental stress evaluation of prototype NEMO capsule, by J. D. Stachiw and K. L. Mack. Port Hueneme, Calif., Oct. 1970. (AD 715772)
- 4.—. Technical Note N-1134: The spherical acrylic pressure hull for hydrospace application, pt. 4. Cyclic fatigue of NEMO capsule #3, by J. D. Stachiw. Port Hueneme, Calif., Oct. 1970. (AD 715345)
- 5.—. Technical Report R-716: Structural analysis of a full-scale spherical acrylic plastic pressure hull, by M. R. Snoey and M. G. Katona. Port Hueneme, Calif., Mar. 1971. (AD 882099L)
- 6.—. Technical Note N-1094: The spherical acrylic pressure hull for hydrospace application, pt. 3. Comparison of experimental and analytical stress evaluations for prototype NEMO capsule, by H. Ottsen. Port Hueneme, Calif., Mar. 1970. (AD 709914)
- 7.—. Technical Report R-749: NEMO, a new concept in submersibles, by P. K. Rockwell, R. E. Elliott, and M. R. Snoey. Port Hueneme, Calif., Nov. 1971. (AD 735103)
8. T. Trowbridge. "Optical properties of a spherical plastic underwater observatory NEMO," *Journal of Engineering for Industry*, vol. 93, no. 2, May 1971, pp. 710-716. (ASME paper no. 70-Unt-A)
9. Naval Personnel and Training Research Laboratory. Technical Bulletin STB-71-8: Size and distance estimation from an acrylic submersible, by C. L. Eversole. San Diego, Calif., Mar. 1971. (AD 722320)

DISTRIBUTION LIST

SNDL Code	No. of Activities	Total Copies	
—	1	12	Defense Documentation Center
FKAIC	1	10	Naval Facilities Engineering Command
FKNI	6	6	NAVFAC Engineering Field Divisions
FKN5	9	9	Public Works Centers
FA25	1	1	Public Works Center
—	9	9	RDT&E Liaison Officers at NAVFAC Engineering Field Divisions and Construction Battalion Centers
—	257	257	NCEL Special Distribution List for persons and activities interested in reports on Deep Ocean Studies

Naval Civil Engineering Laboratory

OPERATIONAL EVALUATION OF NEMO, AN ACRYLIC-HULLED SUBMERSIBLE, by P. K. Rockwell and H. J. Migliore
TR-778 18 p. illus November 1972 Unclassified

1. Acrylic plastic submersible 2. Hydrospace operations I. YF 38.535.005.01.006

The Naval Civil Engineering Laboratory has conducted an operational evaluation of NEMO (Naval Experimental Manned Observatory), an acrylic-hulled submersible. The objectives of the program were to determine the benefits of the panoramic visibility afforded by the transparent acrylic plastic hull, to evaluate the overall design and modes of operation of NEMO, and to judge the potential application of NEMO-type vehicles to the Navy's oceanographic and ocean engineering needs. It is concluded that (1) visibility through the hull is free from shape distortion, making NEMO an excellent observation platform, (2) objects look smaller and closer than actual, (3) operator comfort is good, (4) design of the vehicle is basically sound, simple, and reliable, (5) vehicle operation has been demonstrated to be safe, and (6) NEMO's versatility and usefulness are hampered by the lack of a true hovering/flying capability. It is recommended that future transparent-hulled vehicles have more mobility than NEMO and that a manipulation arm be added.

Naval Civil Engineering Laboratory

OPERATIONAL EVALUATION OF NEMO, AN ACRYLIC-HULLED SUBMERSIBLE, by P. K. Rockwell and H. J. Migliore
TR-778 18 p. illus November 1972 Unclassified

1. Acrylic plastic submersible 2. Hydrospace operations I. YF 38.535.005.01.006

The Naval Civil Engineering Laboratory has conducted an operational evaluation of NEMO (Naval Experimental Manned Observatory), an acrylic-hulled submersible. The objectives of the program were to determine the benefits of the panoramic visibility afforded by the transparent acrylic plastic hull, to evaluate the overall design and modes of operation of NEMO, and to judge the potential application of NEMO-type vehicles to the Navy's oceanographic and ocean engineering needs. It is concluded that (1) visibility through the hull is free from shape distortion, making NEMO an excellent observation platform, (2) objects look smaller and closer than actual, (3) operator comfort is good, (4) design of the vehicle is basically sound, simple, and reliable, (5) vehicle operation has been demonstrated to be safe, and (6) NEMO's versatility and usefulness are hampered by the lack of a true hovering/flying capability. It is recommended that future transparent-hulled vehicles have more mobility than NEMO and that a manipulation arm be added.

Naval Civil Engineering Laboratory

OPERATIONAL EVALUATION OF NEMO, AN ACRYLIC-HULLED SUBMERSIBLE, by P. K. Rockwell and H. J. Migliore
TR-778 18 p. illus November 1972 Unclassified

1. Acrylic plastic submersible 2. Hydrospace operations I. YF 38.535.005.01.006

The Naval Civil Engineering Laboratory has conducted an operational evaluation of NEMO (Naval Experimental Manned Observatory), an acrylic-hulled submersible. The objectives of the program were to determine the benefits of the panoramic visibility afforded by the transparent acrylic plastic hull, to evaluate the overall design and modes of operation of NEMO, and to judge the potential application of NEMO-type vehicles to the Navy's oceanographic and ocean engineering needs. It is concluded that (1) visibility through the hull is free from shape distortion, making NEMO an excellent observation platform, (2) objects look smaller and closer than actual, (3) operator comfort is good, (4) design of the vehicle is basically sound, simple, and reliable, (5) vehicle operation has been demonstrated to be safe, and (6) NEMO's versatility and usefulness are hampered by the lack of a true hovering/flying capability. It is recommended that future transparent-hulled vehicles have more mobility than NEMO and that a manipulation arm be added.

Naval Civil Engineering Laboratory

OPERATIONAL EVALUATION OF NEMO, AN ACRYLIC-HULLED SUBMERSIBLE, by P. K. Rockwell and H. J. Migliore
TR-778 18 p. illus November 1972 Unclassified

1. Acrylic plastic submersible 2. Hydrospace operations I. YF 38.535.005.01.006

The Naval Civil Engineering Laboratory has conducted an operational evaluation of NEMO (Naval Experimental Manned Observatory), an acrylic-hulled submersible. The objectives of the program were to determine the benefits of the panoramic visibility afforded by the transparent acrylic plastic hull, to evaluate the overall design and modes of operation of NEMO, and to judge the potential application of NEMO-type vehicles to the Navy's oceanographic and ocean engineering needs. It is concluded that (1) visibility through the hull is free from shape distortion, making NEMO an excellent observation platform, (2) objects look smaller and closer than actual, (3) operator comfort is good, (4) design of the vehicle is basically sound, simple, and reliable, (5) vehicle operation has been demonstrated to be safe, and (6) NEMO's versatility and usefulness are hampered by the lack of a true hovering/flying capability. It is recommended that future transparent-hulled vehicles have more mobility than NEMO and that a manipulation arm be added.

Naval Civil Engineering Laboratory

OPERATIONAL EVALUATION OF NEMO, AN ACRYLIC-HULLED SUBMERSIBLE, by P. K. Rockwell and H. J. Migliore
TR-778 18 p. illus November 1972 Unclassified

1. Acrylic plastic submersible 2. Hydrospace operations I. YF 38.535.005.01.006

The Naval Civil Engineering Laboratory has conducted an operational evaluation of NEMO (Naval Experimental Manned Observatory), an acrylic-hulled submersible. The objectives of the program were to determine the benefits of the panoramic visibility afforded by the transparent acrylic plastic hull, to evaluate the overall design and modes of operation of NEMO, and to judge the potential application of NEMO-type vehicles to the Navy's oceanographic and ocean engineering needs. It is concluded that (1) visibility through the hull is free from shape distortion, making NEMO an excellent observation platform, (2) objects look smaller and closer than actual, (3) operator comfort is good, (4) design of the vehicle is basically sound, simple, and reliable, (5) vehicle operation has been demonstrated to be safe, and (6) NEMO's versatility and usefulness are hampered by the lack of a true hovering/flying capability. It is recommended that future transparent-hulled vehicles have more mobility than NEMO and that a manipulation arm be added.

Naval Civil Engineering Laboratory

OPERATIONAL EVALUATION OF NEMO, AN ACRYLIC-HULLED SUBMERSIBLE, by P. K. Rockwell and H. J. Migliore
TR-778 18 p. illus November 1972 Unclassified

1. Acrylic plastic submersible 2. Hydrospace operations I. YF 38.535.005.01.006

The Naval Civil Engineering Laboratory has conducted an operational evaluation of NEMO (Naval Experimental Manned Observatory), an acrylic-hulled submersible. The objectives of the program were to determine the benefits of the panoramic visibility afforded by the transparent acrylic plastic hull, to evaluate the overall design and modes of operation of NEMO, and to judge the potential application of NEMO-type vehicles to the Navy's oceanographic and ocean engineering needs. It is concluded that (1) visibility through the hull is free from shape distortion, making NEMO an excellent observation platform, (2) objects look smaller and closer than actual, (3) operator comfort is good, (4) design of the vehicle is basically sound, simple, and reliable, (5) vehicle operation has been demonstrated to be safe, and (6) NEMO's versatility and usefulness are hampered by the lack of a true hovering/flying capability. It is recommended that future transparent-hulled vehicles have more mobility than NEMO and that a manipulation arm be added.

Naval Civil Engineering Laboratory

OPERATIONAL EVALUATION OF NEMO, AN ACRYLIC-HULLED SUBMERSIBLE, by P. K. Rockwell and H. J. Migliore
TR-778 18 p. illus November 1972 Unclassified

1. Acrylic plastic submersible 2. Hydrospace operations I. YF 38.535.005.01.006

The Naval Civil Engineering Laboratory has conducted an operational evaluation of NEMO (Naval Experimental Manned Observatory), an acrylic-hulled submersible. The objectives of the program were to determine the benefits of the panoramic visibility afforded by the transparent acrylic plastic hull, to evaluate the overall design and modes of operation of NEMO, and to judge the potential application of NEMO-type vehicles to the Navy's oceanographic and ocean engineering needs. It is concluded that (1) visibility through the hull is free from shape distortion, making NEMO an excellent observation platform, (2) objects look smaller and closer than actual, (3) operator comfort is good, (4) design of the vehicle is basically sound, simple, and reliable, (5) vehicle operation has been demonstrated to be safe, and (6) NEMO's versatility and usefulness are hampered by the lack of a true hovering/flying capability. It is recommended that future transparent-hulled vehicles have more mobility than NEMO and that a manipulation arm be added.

Naval Civil Engineering Laboratory

OPERATIONAL EVALUATION OF NEMO, AN ACRYLIC-HULLED SUBMERSIBLE, by P. K. Rockwell and H. J. Migliore
TR-778 18 p. illus November 1972 Unclassified

1. Acrylic plastic submersible 2. Hydrospace operations I. YF 38.535.005.01.006

The Naval Civil Engineering Laboratory has conducted an operational evaluation of NEMO (Naval Experimental Manned Observatory), an acrylic-hulled submersible. The objectives of the program were to determine the benefits of the panoramic visibility afforded by the transparent acrylic plastic hull, to evaluate the overall design and modes of operation of NEMO, and to judge the potential application of NEMO-type vehicles to the Navy's oceanographic and ocean engineering needs. It is concluded that (1) visibility through the hull is free from shape distortion, making NEMO an excellent observation platform, (2) objects look smaller and closer than actual, (3) operator comfort is good, (4) design of the vehicle is basically sound, simple, and reliable, (5) vehicle operation has been demonstrated to be safe, and (6) NEMO's versatility and usefulness are hampered by the lack of a true hovering/flying capability. It is recommended that future transparent-hulled vehicles have more mobility than NEMO and that a manipulation arm be added.

Unclassified

Security Classification

DOCUMENT CONTROL DATA - R & D		
<i>(Security classification of title, body of abstract and indexing annotation must be entered when the overall report is classified)</i>		
1. ORIGINATING ACTIVITY <i>(Corporate author)</i> Naval Civil Engineering Laboratory Port Hueneme, California 93043		2a. REPORT SECURITY CLASSIFICATION Unclassified
		2b. GROUP
3. REPORT TITLE OPERATIONAL EVALUATION OF NEMO, AN ACRYLIC-HULLED SUBMERSIBLE		
4. DESCRIPTIVE NOTES <i>(Type of report and inclusive dates)</i> Not final; May 1970—February 1972		
5. AUTHOR(S) <i>(First name, middle initial, last name)</i> P. K. Rockwell and H. J. Migliore		
6. REPORT DATE November 1972	7a. TOTAL NO. OF PAGES 18	7b. NO. OF REFS 9
8a. CONTRACT OR GRANT NO.	9a. ORIGINATOR'S REPORT NUMBER(S) TR-778	
b. PROJECT NO. YF 38.535.005.01.006		
c.	9b. OTHER REPORT NO(S) <i>(Any other numbers that may be assigned this report)</i>	
d.		
10. DISTRIBUTION STATEMENT Approved for public release; distribution unlimited.		
11. SUPPLEMENTARY NOTES	12. SPONSORING MILITARY ACTIVITY Naval Facilities Engineering Command Washington, D. C. 20390	
13. ABSTRACT <p>The Naval Civil Engineering Laboratory has conducted an operational evaluation of NEMO (Naval Experimental Manned Observatory), an acrylic-hulled submersible. The objectives of the program were to determine the benefits of the panoramic visibility afforded by the transparent acrylic plastic hull, to evaluate the overall design and modes of operation of NEMO, and to judge the potential application of NEMO-type vehicles to the Navy's oceanographic and ocean engineering needs. It is concluded that (1) visibility through the hull is free from shape distortion, making NEMO an excellent observation platform, (2) objects look smaller and closer than actual, (3) operator comfort is good, (4) design of the vehicle is basically sound, simple, and reliable, (5) vehicle operation has been demonstrated to be safe, and (6) NEMO's versatility and usefulness are hampered by the lack of a true hovering/flying capability. It is recommended that future transparent-hulled vehicles have more mobility than NEMO and that a manipulation arm be added.</p>		

Unclassified

Security Classification

14 KEY WORDS	LINK A		LINK B		LINK C	
	ROLE	WT	ROLE	WT	ROLE	WT
NEMO Submersible Spherical pressure hull Acrylic plastic Hydrospace Transparent hull Manned submersible						

Unclassified

Security Classification