

OK
and
1/28/92

Rec'd 8/6/62

UCRL 7255

University of California Ernest O. Lawrence Radiation Laboratory

19960424 045

DISTRIBUTION STATEMENT A
Approved for public release;
Distribution Unlimited

VISCOELASTICITY OF POLYMERS

DEPARTMENT OF DEFENSE
PLASTICS TECHNICAL EVALUATION CENTER
PICATINNY ARSENAL, DOVER, N. J.

Livermore, California

UNCLASSIFIED/UNLIMITED

DTIC QUALITY INSPECTED 1

PLASTIC
5650 0395

DISCLAIMER NOTICE

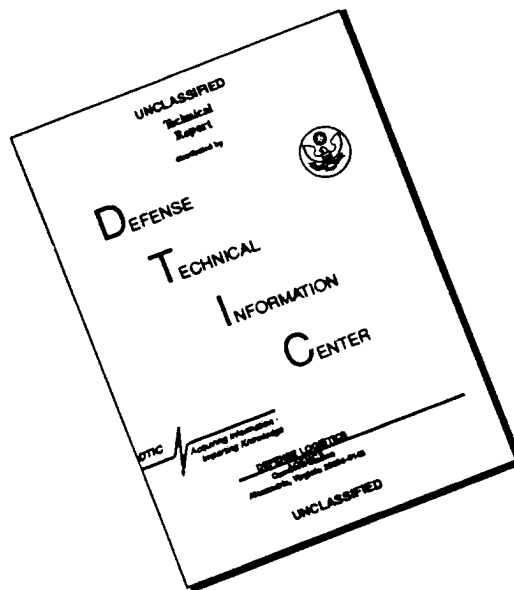

THIS DOCUMENT IS BEST QUALITY AVAILABLE. THE COPY FURNISHED TO DTIC CONTAINED A SIGNIFICANT NUMBER OF PAGES WHICH DO NOT REPRODUCE LEGIBLY.

UNIVERSITY OF CALIFORNIA
Lawrence Radiation Laboratory
Livermore, California

Contract No. W-7405-eng-48

VISCOELASTICITY OF POLYMERS

Maurice Zaslavsky

February 26, 1963

CONTENTS

	<u>Page No.</u>
Abstract	
Introduction	1
Phenomenological Aspects	2
Mathematical Relationships	8
Experimental Aspects	22
The Combined Stress Viscoelastic Project at LRL	24
Summary	29
References	31

VISCOELASTICITY OF POLYMERS

Maurice Zaslavsky

Lawrence Radiation Laboratory, University of California

Livermore, California

February 26, 1963

ABSTRACT

A review of the state of the art of viscoelasticity from the applied mechanics standpoint is presented. Both linear and nonlinear viscoelasticity is discussed with reference to both the theoretical and experimental aspects. A simple design problem is used as an example and extensions of the problem are discussed. The experimental approach of the Combined Stress Viscoelastic Project at Lawrence Radiation Laboratory is presented.

VISCOELASTICITY OF POLYMERS

Maurice Zaslowsky

Lawrence Radiation Laboratory, University of California

Livermore, California

February 26, 1963

INTRODUCTION

This paper discusses the phenomenological, mathematical, and experimental aspects of viscoelasticity and relates them to the experimental work being done at Lawrence Radiation Laboratory (LRL). The portion dealing with phenomenological aspects describes the relationship between molecular structure of a polymer and its associated mechanical properties. The relationships between time, temperature, stress, and strain are discussed. Included is a discussion on the ability to compress the time scale by increasing the test temperature (time-temperature shift). The theory of mechanical equivalence is discussed. This theory states that materials which have certain identical physical properties are expected to have identical mechanical properties. The Boltzmann superposition principle is described along with a comparison of the strain-hardening and time-hardening theories.

The mathematical section gives an example of a viscoelastic stress analysis for a relatively simple problem by means of mechanical models and by so-called "empirical" means. The methods for handling nonlinear problems, variations in temperature, and a generalized state of stress are discussed. The conversion of a viscoelastic stress analysis into an elastic stress analysis by the use of the Laplace transform is described.

The section on experimental aspects explains the relationship between creep, stress relaxation, constant crosshead velocity, sinusoidal, and birefringence tests.

The objective of the LRL experimental research effort is primarily to determine the applicability of the existing equations and develop more adequate equations where needed for the stress-strain relationship of linear and nonlinear viscoelasticity as a function of stress state, temperature, and humidity.

A secondary object is to determine whether the arbitrary criterion of failure (by excessive flow) as used on metals at high temperature is applicable to viscoelasticity.

Two other papers are scheduled to follow this one. The first will discuss the experimental apparatus in detail, and the second will compare the experimental results with existing theory, and possibly propose new theory.

THE PHENOMENOLOGICAL ASPECTS

The object of this section is to classify viscoelasticity as a phenomenon and indicate the conditions under which it occurs.

The Structure of Polymers

The structure of organic materials is complex; it does not exhibit grains nor does it appear to operate under the same kind of mechanisms as one finds in metals. In general, polymers can be classified as crystalline, amorphous, or combinations of the two. Crystalline polymers are polymers whose molecules are arranged in a definite geometric array. Amorphous polymers are ones whose molecular chains intertwine with one another and represent no pattern at all. X-ray and Geiger counter techniques are used to distinguish between amorphous and crystalline constituents in a polymer. Dislocations, which account for flow in metals at moderate stresses, have been observed

in polymers that are 90% or more crystalline (1).¹ In less crystalline

¹ The numbers in parentheses refer to the list of references at the end of this paper.

polymers, dislocations have not been observed. It can be readily noted that in such semicrystalline polymers, the relationships between the state of stress and strain under various temperature and humidity conditions are more complex and therefore more difficult to describe than in the wholly amorphous or wholly crystalline polymers. The mechanical properties of such semicrystalline polymers are more dependent on the amorphous constituent than on the crystalline constituent (2).

Linear Viscoelasticity

While it is indeed true that we live in a nonlinear world, little progress has been made as yet in solving nonlinear problems. Linear approximations to them are often attempted. Linear viscoelasticity results in differential equations in which the function and its derivatives appear only in the first degree, i. e.,

$$A \frac{\partial^2 u}{\partial x^2} + B \frac{\partial^2 u}{\partial x \partial y} + C \frac{\partial^2 u}{\partial y^2} + D \frac{\partial u}{\partial x} + E \frac{\partial u}{\partial y} + Fu = G(x,y). \quad (1)$$

Nonlinear theory results in equations like

$$\frac{\partial^2 u}{\partial x^2} + 2u \frac{\partial u}{\partial y} = 3xy, \quad (2)$$

where $u \frac{\partial u}{\partial y}$ is the nonlinear term (3). Such equations are difficult or impossible to solve exactly. Therefore, much concentrated effort must be made in the nonlinear theory with the object of obtaining a general solution which will incorporate linear effects.

The following questions arise: 1. How do you know when a material behaves linearly? 2. How do you define the mathematical relationship between stress, strain, and time? Consideration of the second question will be deferred until later.

Viscoelasticity is concerned with the time dependence of a material. If one were to run creep tests, for example, the load or stress would be independent of time but the deformation would be a function of time. This can be seen in Fig. 1; $\epsilon_1(t)$ is the resultant deformation of σ_1 . Doubling σ_1 would result in a deformation of $2\epsilon_1(t)$, if the material behaved linearly. If the function were other than $2\epsilon_1(t)$, then the material would be nonlinear and nonlinear differential equations would be required to describe such behavior. The conditions under which linear theory is realistic are extremely limited. Linearity limits are given in Table 1.4 of ref. (4), for several plastics and rubbers. Experiments by Leaderman, Marin and others, on which Table 1.4 of ref. (4) is based, indicate that the assumption of linearity is valid up to several percent strain. Tobolsky (1) and Staverman and Schwarzl (5) have indicated that linear theory (especially when extended to include temperature) is generally not applicable to semicrystalline polymers. However, if the magnitude of strain in semicrystalline polymers is considerably reduced as compared with amorphous polymers, then linear theory may be applicable. Hence the linearity limit goes from (for example) 3% to 0.3%. In the recent rheology conference at Johns Hopkins (6) several papers were presented wherein linear theory was applied to semicrystalline polymers, because for many engineering applications the interest is in small deformations.

Relationship Between Viscoelastic Behavior and Molecular Structure

At the present time, little has been determined as to the relationship between the mechanical behavior of polymers and their structure. The polymer

chains coil, uncoil, slip past one another. To understand the total effect or spectrum of such interactions for a linear material becomes mathematically very difficult. It is felt that the heart of the solution to polymer physics lies in thermodynamics; however, the subject of thermodynamics is itself very complex and thermodynamic experiments on polymers are extremely difficult. Therefore, other experimental techniques have been used to extend the area of knowledge. Tobolsky, in his recent book (1), summarizes what he has done in relating experimental viscoelasticity to molecular structure. Tobolsky has stated two theories regarding the mechanical properties of polymers and molecular structure: (a) Two amorphous polymers are mechanically equivalent if their glass transition temperatures, melting temperatures, and chain lengths are equivalent. (b) Two crystalline polymers are mechanically equivalent if they have equivalent glass temperature, melting temperature, chain length, percent crystallinity, and crystalline texture.

In an effort to understand the molecular structure of polymers better, attempts have been made to study the polymers in their fluid or viscous regions. In this way, the motion of molecules can be studied in relation to other molecules. General experiments such as sinusoidal, creep, or stress relaxation tests can be used. Several theories have been suggested as a result of this experimental effort (4, 6).

The Conditions under which a Polymer will be Viscoelastic

The total deformation that occurs under a particular load, σ_1 , can be broken up into the sum of the deformations which are a result of different phenomena (4).

$$\sum_{i=1}^3 \epsilon_i = \epsilon_1 + \epsilon_2 + \epsilon_3 \tag{3}$$

where ϵ_1 is the elastic (time-independent) strain; ϵ_2 is the viscoelastic (time-dependent) strain; ϵ_3 is the viscous strain, $\sigma_1 t / \rho$, where ρ is the viscosity and t is time. At room temperature ρ is extremely large and ϵ_1 can be considered negligible, therefore one has primarily ϵ_2 . If the temperature increases and the polymer is amorphous, then the viscous effect will begin to become the dominant term; or if the polymer is crosslinked, then ρ will still be very large. If the temperature is lowered ϵ_2 becomes smaller and ϵ_1 becomes more significant. Crystallites or bulky side groups assist in retarding flow (7).

Viscoelastic Deformation and the Shift Function

In the previous section the effect of temperature has been considered. The objective is to mathematically correlate time, temperature, stress, and strain. The particular correlation for linear materials is referred to as the time-temperature superposition principle and makes use of a shift function. The shift function relates time and temperature. A material sees elastic and viscoelastic deformation $\epsilon_1 + \epsilon_2(t)$, as shown in Fig. 2.

By shifting such a curve with respect to the time axis, the effect at another temperature can be obtained. The shift function can include both vertical and horizontal shifts. If a shift function is applicable to a linear viscoelastic material, then the polymer is referred to as a thermorheologically simple (5) material. This is important not only in characterizing a material, but for analysis (8). For polymethyl methacrylate (Lucite),

$$\phi(T) = 10^{3.6} \exp \left\{ \frac{-6.908}{10^3} (110-T) \left[T - 40 + 0.0365(T - 80)^2 \right] \right\} \quad (4)$$

where T is in degrees centigrade, and $\phi(T)$ is the shift function. The temperature range where this is valid is 80-110°C.

It should be noted that linear viscoelastic deformation is recoverable, provided sufficient time has been allowed for the polymer to relax. Non-linear viscoelastic recoverable deformation is discussed later. If the load is removed, one instantly obtains the elastic deformation, and after sufficient time the viscoelastic deformation reaches an asymptotic value. The difference between this value and zero is the permanent deformation ϵ_3 . Furthermore, ϵ and σ can be tensile, compressive, or shear strains and stresses, and the material properties needed (e.g., ρ) are to be consistent.

Superposition Principle, Strain Hardening, Time Hardening, and Mechanical Equations of State (9)

It is the ability to predict the resultant strain from a known load, or vice versa, that is the objective of analysis. The four theories mentioned above are attempts at this.

The Boltzmann superposition principle states that the stresses and their resultant strains are additive. This is actually the linearity concept as shown in Fig. 1.

If $\epsilon_1(t)$ is a result of σ_1 , and $\epsilon_2(t)$ is a result of σ_2 , then $\epsilon_1(t) + \epsilon_2(t)$ is a result of $\sigma_1 + \sigma_2$. The relationship is reversed for stress relaxation, and $\sigma_1(t) + \sigma_2(t)$ is the result of $\epsilon_1 + \epsilon_2$.

The strain hardening and time hardening theories are illustrated by Fig. 3. A creep test is performed at a stress level σ_1 (test 1), and another creep test is performed at a higher stress level, σ_2 (test 2). At time t_1 the stress level of test 1 is increased to σ_2 . If the strain hardening theory is applicable, the test 1 curve to the right of t_1 will parallel the test 2 curve to the right of point A; if the time hardening theory is applicable, the test 1 curve to the right of t_1 will parallel the test 2 curve to the right of point B.

The mechanical equation of state indicates that the stress is a function of both strain rate and temperature. It assumes that the material does not change in getting to a particular stress state nor does the direction taken in any stress space in arriving at a given point yield different results. It should be noted that amorphous polymers do not have a well-defined structure, so that the mechanical equation of state may be applicable.

An investigation by Findley and Khosla (10) on four unfilled thermoplastics indicated that the mechanical equation of state is applicable when the stress is constant or increasing, and the superposition principle predicted results closer than the strain hardening theory which in turn predicted closer results than the time hardening theory (36% off). It should be noted that the maximum deformation never exceeded 4% in this investigation.

The principal objective of our work is to relate the mechanical properties of plastics to engineering design problems. Of course, the chemistry portion of the problem cannot be ignored. Consequently we will note molecular structure (e. g., molecular weight, monomer content) but leave the study of molecular motion to rheologists who have a greater chemistry background.

MATHEMATICAL RELATIONSHIPS

Even simple problems in viscoelasticity require difficult mathematics, and therefore a viscoelastic solution has not been attempted by most engineers. In addition, limitations on solvable problems have made many engineers feel that these solutions are too unrealistic. However, the present effort in research is devoted to elimination of as many as possible of these restrictions. Final mathematical relationships should be comparable to elastic solutions given in Roark (11) and therefore be easily usable by the working engineer.

No matter how anyone may look at this problem, a viscoelastic solution, where obtainable, is much superior to an elastic solution when viscoelastic

materials are employed. The elastic solution may have meaning at $t = 0$ and at temperatures below room temperature, where the elastic modulus is independent of time. The limiting stress, the so-called yield strength, has no meaning when applied to polymers at any temperature above the glass temperature. This then brings up the criterion of failure, which for polymers appears to be arbitrary and can be set by the designers. Functional tests of whole components are a means of checking an analysis for a particular problem, but they are highly expensive.

It was pointed out in the last section that the Boltzmann superposition principle is a reasonably good approximation for linear viscoelasticity. That

is, $\sum_{i=1}^N \sigma_i$ correlates with $\sum_{i=1}^N \epsilon_i(t)$. The question that of course arises is how

can σ_1 be related to $\epsilon_1(t)$ in an equation? If this can be determined then σ_i can be related to $\epsilon_i(t)$. Note that the process is reversible: ϵ_i can be correlated to $\sigma_i(t)$.

The approach taken is to use models consisting of springs and dashpots, the spring representing the elastic response, and the dashpot representing the viscous effect. Typical models are those of Kelvin, Maxwell, and Burger (4, 12, 13, 14). The plan of this section is to solve a typical problem, with notes and references on how the solution could be extended to other problems (15).

Statement of Problem

A constant force P is applied to a rod of length ℓ and area a for a period t_1 , at room temperature, T_r . If the deflection δ in the direction P is kept below δ_1 , what is the maximum force P that can be applied and which is the best material? Humidity will be assumed not to be a problem and $\delta_1/\ell = \epsilon_1$ is of the order of a few percent.

One solution of course can be to take many rods and subject them to tensile creep tests. If the temperature in the problem changed to a value other than T_r , or the geometry changed, an infinite number of tests would have to be run.

The elastic solution would be

$$\sigma = P/a, \quad (5)$$

$$\delta/l = \epsilon = \sigma/E \quad (6)$$

where E is the modulus of elasticity. The fact that we are dealing with an ϵ_1 of the order of a few percent makes the theory of linear viscoelasticity applicable. After final selection of a material, tests should be included that will check this assumption.

From the problem it is evident that P is independent of time, and since a viscoelastic material is selected ϵ will be a function of time, $\epsilon(t)$. Therefore

$$\epsilon_1 = \epsilon(t_1) = \delta(t_1)/l \quad (7)$$

where $\delta \leq \delta_1$. The material property E is the relation between σ and ϵ . This relation can be described by models as discussed earlier.

The Kelvin model (see Fig. 4) will be used in this problem. For most materials, the simple models will not describe the material adequately. Therefore more complex models, like a generalized Kelvin model, may be used when more accurate descriptions are required. The abundant computer facilities at LRL permit handling such complexities.

The stress in the spring (Fig. 4) is $K_1\epsilon$ and the stress in the dashpot is $K_2 \frac{d\epsilon}{dt}$. From equilibrium,

$$\sigma = \sigma_1 + \sigma_2 \quad (8)$$

$$= K_1 \epsilon + K_2 \frac{d\epsilon}{dt} = K_1 \epsilon + K_2 \frac{d}{dt} (\epsilon) \quad (9)$$

$$= \epsilon \left[K_1 + K_2 \frac{d}{dt} \right]. \quad (10)$$

$$\frac{\sigma}{\epsilon} = E(t) = \left[K_1 + K_2 \frac{d}{dt} \right], \quad (11)$$

where $E(t)$ is a time-dependent modulus.

$$\delta = \frac{P}{a} \frac{l}{E}, \quad (6)$$

the elasticity solution. Now replacing E by $E(t)$ and δ by $\delta(t)$, note that P is independent of t .

$$\delta(t) = \frac{P}{a} \frac{l}{E(t)} \quad (12)$$

$$= \frac{Pl}{a} \frac{1}{K_1 + K_2 \frac{d}{dt}}. \quad (13)$$

$$\left[K_1 + K_2 \frac{d}{dt} \right] \delta(t) = \frac{Pl}{a}.$$

$$K_1 \delta(t) + K_2 \frac{d\delta(t)}{dt} = \frac{Pl}{a} \left(\frac{1}{K_2} \right). \quad (14)$$

Equation (14) is a linear differential equation. If the material was nonlinear Eq. (14) would not be linear. Now we solve (14).

$$\frac{d\delta(t)}{dt} + \frac{K_1}{K_2} \delta(t) = \frac{Pl}{aK_2},$$

$$\therefore \delta(t) = C_1 \exp \left(- \frac{K_1}{K_2} t \right) + \frac{1}{K_1} \frac{Pl}{a}. \quad (15)$$

From the initial condition of the problem $t = 0$, $\delta(t) = \delta(0) = 0$.

$$C_1 = -\frac{Pl}{aK_1}, \quad (16)$$

$$\begin{aligned} \therefore \delta(t) &= -\frac{Pl}{aK_1} \exp\left(-\frac{K_1}{K_2}t\right) + \frac{1}{K_1} \frac{Pl}{a} \\ &= \frac{1}{K_1} \left(\frac{Pl}{a}\right) \left[1 - \exp\left(-\frac{K_1}{K_2}t\right)\right]. \end{aligned} \quad (17)$$

Since $\delta(t_1) \cong \delta_1$

$$\text{then } \delta_1 = \frac{1}{K_1} \frac{Pl}{a} \left[1 - \exp\left(-\frac{K_1}{K_2}t_1\right)\right]. \quad (18)$$

Solving for P, we get

$$P = \frac{\delta_1 K_1 a}{l} \frac{1}{1 - \exp\left(-\frac{K_1}{K_2}t_1\right)}. \quad (19)$$

From Eq. (19) it is seen that the only unknown is P; K_1 , K_2 are constants determined for a particular material. In this case, it would be best to run tensile creep curves for times of the order of t_1 . The constants K_1 and K_2 should be independent of stress since they are material properties.

Determining K_1 and K_2 may be done as follows.

$$\frac{\sigma}{\varepsilon} = K_1 + K_2 \frac{d}{dt}. \quad (11)$$

From a tensile creep test in the linear range, of order σ_1 , t_1 , T_r ,

$$\sigma_1 = K_1 \varepsilon + K_2 \frac{d\varepsilon}{dt} \quad \text{or} \quad \frac{d\varepsilon}{dt} + \frac{K_1}{K_2} \varepsilon = \frac{\sigma_1}{K_2}. \quad (20)$$

Equation (20) is a linear differential equation.

$$\epsilon = C \exp\left(-\frac{K_1}{K_2}t\right) + \frac{\sigma_1}{K_1}. \quad (21)$$

The boundary conditions $t = 0, \epsilon = 0, \sigma = \sigma_1$ (see Fig. 5) give

$$0 = C + \frac{\sigma_1}{K_1}, \quad \text{or} \quad C = -\frac{\sigma_1}{K_1}. \quad (22)$$

$$\therefore \epsilon = -\frac{\sigma_1}{K_1} \exp\left(-\frac{K_1}{K_2}t\right) + \frac{\sigma_1}{K_1} = \frac{\sigma_1}{K_1} \left[1 - \exp\left(-\frac{K_1}{K_2}t\right)\right] = \epsilon(t). \quad (23)$$

The data will determine explicit values of ϵ and t from 0 to t_1 , e.g., ϵ_0, t_0 .

$$\epsilon_0 = \frac{\sigma_1}{K_1} \left[1 - \exp\left(-\frac{K_1}{K_2}t_0\right)\right].$$

σ_1 is a test condition and is known. Therefore K_1 and K_2 can be determined from any two pairs of values of ϵ, t . A material whose values for K_1 and K_2 give the greatest value for P in Eq. (19) is the optimum material.

There is another approach one can take to the solution of such problems (16, 17).

$$\epsilon = mt^n. \quad (24)$$

Equation (24) appears to describe many rigid polymers well; m, n are constants, m being a function of stress (σ), n being independent of stress. A creep test on different materials could determine a series of values for n , then for each value

$$\epsilon_1 = \epsilon(t_1) = \frac{\delta(t_1)}{l} = mt_1^n. \quad (25)$$

The value $m(\sigma_1)$ can be obtained. Hence unique values of $m(\sigma_1)$, n , are obtained for each material. Knowing the value of $m(\sigma_1)$ experimentally (when n was obtained), one can run a test at a different stress level until m_1 is reached. The stress σ_1 is the maximum load for a particular material. Of the materials tested, the one having the largest σ_1 would be selected as optimum. A check should be made at the end to see that n is independent of stress.

The problem used as an example is in itself a creep test. This is felt most when the validity of $\epsilon = mt^n$ is questioned. In this particular problem, the ordinary creep test can determine the validity of the assumptions. It is when multiaxial stress problems arise, and this equation is extended, that there are no longer inexpensive and fast checks of the assumptions (7, 18, 19).

Extensions of the Problem

In working with the Kelvin model, the following relationship was determined

$$\frac{\sigma}{\epsilon} = \left[K_1 + K_2 \frac{d}{dt} \right]; \quad (11)$$

$\frac{d}{dt}$ represents an operation to be performed on a function that varies with t .

As an example $D \left\{ x^2 + 2 \right\} = 2x$ means that $D = d/dx$ is a differential operation on the function $f(x) = x^2 + 2$, and $f'(x) = 2x$. D is therefore called an operator.

$P = d/dt$ is an operator. When more complex models are used the relation above becomes more involved.

$$\begin{aligned} \frac{\sigma}{\epsilon} &= K_2 \frac{d}{dt} + K_1 = \frac{P}{Q} \\ &= \frac{K_{n+1} \frac{d^n}{dt^n} + K_n \frac{d^{n-1}}{dt^{n-1}} + \dots + K_1}{R_{n+1} \frac{d^n}{dt^n} + R_n \frac{d^{n-1}}{dt^{n-1}} + \dots + R_1} \end{aligned} \quad (26)$$

where K_{k+1} and R_{k+1} , where $k = 0, \dots, n$ are the material parameters determined from experiment.

The most simple type of element where $\sigma/\varepsilon = P/Q$ is the Burger model (Fig. 6), with

$$\frac{\sigma}{\varepsilon} = \frac{K_3 \frac{d^2}{dt^2} + K_2 \frac{d}{dt}}{R_3 \frac{d^2}{dt^2} + R_2 \frac{d}{dt} + R_1} \quad (27)$$

Provided the system is linear, an approximate representation of the material is possible.

This means that for a generalized Kelvin model (several simple Kelvin models in series),

$$\varepsilon = \frac{\sigma_1}{K_0} + \sum_{i=1}^n \frac{\sigma_1}{K_i} \left[1 - e^{-t/\tau_i} \right] + \frac{\sigma_1 t}{\rho} \quad (28)$$

where $\frac{\sigma_1 t}{\rho}$ is the viscous term, τ_i is the ratio of spring constant to dashpot constant, and is known as the retardation time, $\frac{\sigma_1}{K_0}$ is the initial elastic strain.

The inverse of the modulus is the compliance ($Y_i = 1/K_i$).

$$\varepsilon(t) = \sigma_1 \sum_{i=1}^{\infty} Y_i \left[1 - e^{-t/\tau_i} \right]$$

Because of the nature of the molecular chain, a continuous function is more nearly correct.

$$\varepsilon(t) = \sigma_1 \int_0^{\infty} Y(\tau) \left(1 - e^{-t/\tau} \right) d\tau \quad (29)$$

where τ is a dummy variable.

Equation (29) represents the integral form of $\epsilon(t)/\sigma_1 = Q/P$. The integral form is equivalent to the operator form Q/P , provided the times under consideration are short. Q/P is not equivalent to the integral form at the upper limit, ∞ , of the integral form. Equation (29), in order to be evaluated, may be transformed to eliminate the integral sign. The Laplace transform is ideally suited for such problems. Recently, Lee and Rogers (20) indicated how numerical integration can be used to solve the integral equations. Using such mathematical techniques, one can go from the integral form to operator form and back again to the integral form.

The other approach, which we will call the empirical approach, is the determination of the best value of (m, n) in Eq. (24) by curve fitting.

The mathematical approach when the problem is nonlinear has only recently been defined. Some nonlinear work has been done from the standpoint of creep of metals at elevated temperatures (21). While creep in both polymers and metals involves time dependence, the phenomena are different, and assumptions involving polymers generally do not correlate with assumptions involving metals. People are working on the nonlinear mathematical approach and a solution is believed possible (22). The empirical approach has the advantage that a solution is readily available by performing a uniaxial test in the nonlinear range, and obtaining the best fit for m and n in Eq. (24). The nonlinear mathematical approach, as far as it has been developed (22), is a most complex subject.

If the problem was extended to include temperature or long time periods, the time-temperature superposition principle could be used.

If the material is linear throughout a temperature region, one could obtain a shift function, which would translate $E(t)$. For example, if one were to perform a creep test at an elevated temperature (above room temperature)

for a short period of time and determine $E(t)$, it would have the same value as an $E(t)$ determined at room temperature at the end of a considerably longer period of time. This shift function can be used in analysis. Furthermore, while it is of course best to run the longer period test at room temperature, one may not have the time or the facilities to run such extended tests. Therefore this extension provides a means whereby useful data can be accumulated in a short time.

In the empirical approach, m and n are probably both functions of temperature.

Most practical applications involve stresses in more than one direction. The elasticity relationship between stress and strain is given by Hooke's generalized law.

$$\epsilon_1 = \frac{\sigma_1}{E} - \frac{\mu}{E} (\sigma_2 + \sigma_3). \quad (30)$$

Permutation of the subscripts 1, 2, 3 will give the strains in the other directions. From the generalized relationship, it is seen that two material properties, μ and E , are needed. When this relationship is extended to linear viscoelasticity, again two relationships are needed. Instead of $\mu(t)$, the shear modulus $G(t)$ is used. Note that $1/G(t) = J(t)$, the shear compliance. For a linear viscoelastic isotropic material showing neither instantaneous elastic deformation nor viscous deformation, the general integral relationship between stress and strain corresponding to Eq. (30) above is (23)

$$\epsilon_{ij}(t) = \sum_{b=1}^N \int_{-\infty}^t \left\{ \left(1 - e^{-\lambda^b(t-\tau)} \right) \left[\alpha^b d\sigma_{ij}(\tau) - \beta^b \delta_{ij} d\sigma_{kk}(\tau) \right] \right\}, \quad (31)$$

$i, j = 1, 2, 3$, τ is a dummy variable.

For the operator form,

$$\frac{E}{2G} - 1 = \mu,$$

$$\varepsilon_1 = \frac{\sigma_1}{E} - \left(\frac{1}{2G} - \frac{1}{E} \right) (\sigma_2 + \sigma_3),$$

$$\varepsilon_1(t) = \frac{\sigma_1}{E(t)} - \left(\frac{1}{2G(t)} - \frac{1}{E(t)} \right) (\sigma_2 + \sigma_3). \quad (32)$$

In Eq. (32), σ is not a function of time; in the integral form σ is given as a function of time (τ), representing the most general case. (Equation (32) can be extended by substituting $\sigma_1 = \sigma_1(t)$, $\sigma_2 = \sigma_2(t)$, $\sigma_3 = \sigma_3(t)$.)

If one were dealing only with the theoretical aspect of linear viscoelasticity, Eq. (31) would be satisfactory. However, in solving real problems it is necessary to use actual material properties. Therefore, let us reduce this general form to one more appropriate. Let $i = j = 1$:

$$\varepsilon_{ij} = \varepsilon_{11} = \varepsilon_x(t).$$

That is, let us determine the normal strain in the x direction, $\varepsilon_x(t)$, in terms of all the stresses, $\sigma_y \neq \sigma_z \neq 0$. We use tensor notations:

$$\sigma_{kk} = \sigma_{11} + \sigma_{22} + \sigma_{33} = \sigma_{xx} + \sigma_{yy} + \sigma_{zz}. \quad (33)$$

$$\delta_{ij} = \begin{cases} 1 & \text{for } i = j, \\ 0 & \text{for } i \neq j. \end{cases}$$

$$\therefore \varepsilon_x(t) = \sum_{b=1}^N \int_{-\infty}^t \left\{ \left(1 - e^{-\lambda^b(t-\tau)} \right) \left[\alpha^b d\sigma_x(\tau) - \beta^b (d\sigma_x(\tau) + d\sigma_y(\tau) + d\sigma_z(\tau)) \right] \right\}. \quad (34)$$

By definition

$$\frac{1}{2G(t')} = \sum_{b=1}^N a^b \left\{ 1 - e^{-\lambda^b t'} \right\} H(t'),$$

where

$$H(t') = \begin{cases} 0 & \text{for } t \leq 0, \\ 1 & \text{for } t > 0. \end{cases}$$

For the elastic case,

$$\beta = \frac{\mu}{E} = \frac{1}{2G} - \frac{1}{E}.$$

Changing to a time-dependent modulus,

$$\frac{1}{2G(t')} - \frac{1}{E(t')} = \sum_{b=1}^N \beta^b \left\{ 1 - e^{-\lambda^b t'} \right\} H(t').$$

Letting $t' = t - \tau$, we get

$$\begin{aligned} \epsilon_x(t) = \int_{-\infty}^t \frac{d\sigma_x(\tau)}{2G(t-\tau)} + \int_{-\infty}^t \left[\frac{1}{E(t-\tau)} - \frac{1}{2G(t-\tau)} \right] \\ \left[d\sigma_x(\tau) + d\sigma_y(\tau) + d\sigma_z(\tau) \right]. \end{aligned} \quad (35)$$

In terms of the compliance rather than moduli,

$$\epsilon_x(t) = \int_{-\infty}^t \frac{J(t-\tau)}{2} d\sigma_x(\tau) + \int_{-\infty}^t \left[Y(t-\tau) - \frac{1}{2} J(t-\tau) \right] \left[d\sigma_x(\tau) + \dots + d\sigma_z(\tau) \right]. \quad (36)$$

Therefore it is seen that if $G(t)$ and $E(t)$ are known through creep or relaxation experiments in shear and uniaxial tension, respectively, the entire stress-strain relation is given by (36) for linear strains in the x direction.

In terms of all the stresses as a function of all the strains,

$$\sigma_x(t) = 2 \int_{-\infty}^t G(t-\tau) d\epsilon_x(\tau) + \int_{-\infty}^t \left[E(t-\tau) - \frac{2}{3}G(t-\tau) \right] \left[d\epsilon_x(\tau) + d\epsilon_y(\tau) + d\epsilon_z(\tau) \right]. \quad (37)$$

The preceding relationships are valid for linear viscoelasticity. Only recently has the problem been defined mathematically for nonlinear viscoelasticity. However, it appears that it will take many years for the solution.

Onaran and Findley (18) have suggested an equation which would be used in the linear as well as the nonlinear region.

$$\epsilon_{ij}(t) = \delta_{ij} \left\{ \sum_{a=0}^N \left[\epsilon_0' F_1(\sigma_{kk}) - e_0' F_2(\sigma_{kk}) + m'(t - \xi_a)^n F_3(\sigma_{kk}) - p'(t - \xi_a)^q F_4(\sigma_{kk}) \right] \right\} + \sum_{a=0}^N \left[e_0' F_2(\sigma_{ij}) + p'(t - \xi_a)^q F_4(\sigma_{ij}) \right], \quad (38)$$

where $F_1(\sigma)$, $F_2(\sigma)$, $F_3(\sigma)$, $F_4(\sigma)$ are nonlinear stress functions; ϵ_0' , m' , n , e_0' , p' , q are experimental constants. For uniaxial tensile creep, Eq. (38) reduces to an equation similar to Eq. (24).

A question that is as yet unanswered is how valid is Eq. (38)?

Use of the Laplace Transform and Correspondence Principle

There are two items that should be included in this section to make the report complete: the Laplace transform and the correspondence principle (24, 25).

If $Y(t)$ is a continuous function² of t , then

²With a slight modification, the theory here can be extended to sectionally (piecewise) continuous functions.

$$y(s) = \int_0^{\infty} e^{-st} Y(t) dt = \mathcal{L}Y(t), \quad (39)$$

$$\mathcal{L}^{-1} y(s) = Y(t), \quad (40)$$

where \mathcal{L} is the one-sided Laplace transform of the function $Y(t)$, and \mathcal{L}^{-1} is the inverse one-sided Laplace transform of the function $y(s)$. For derivatives of $Y(t)$, the Laplace transform is

$$\mathcal{L}Y^{(n)}(t) = s^n y(s) - s^{n-1}Y(0) - s^{n-2}Y'(0) - s^{n-3}Y''(0) \dots, \quad (41)$$

for example, when $Y^{(n)}(t) = Y''(t)$, then from Eq. (41),

$$\begin{aligned} \mathcal{L}Y''(t) &= s^2 y(s) - sY(0) - Y'(0) \\ &= s^2 \mathcal{L}Y(t) - sY(0) - Y'(0). \end{aligned}$$

It can be seen that with the aid of Eq. (41) many differential equations can be easily solved.

In addition to the continuity of $Y(t)$, the theory of Laplace transforms is based also on the concept that $Y(t)$ does not grow faster than Me^{at} as t goes to infinity, where M and a are constants. This is referred to as the exponential order of the function $Y(t)$.

An important aid in solving viscoelastic problems makes use of the convolution theorems. The convolution of two functions $Y(t)$ and $G(t)$ is defined as

$$Y(t)*G(t) = \int_0^t Y(\tau)G(t-\tau) d\tau. \quad (42)$$

if $y(s)$ and $g(s)$ are the Laplace transforms of $Y(t)$ and $G(t)$, respectively, then

$$y(s)g(s) = \mathcal{L}\left\{Y(t)*G(t)\right\} = \int_0^{\infty} e^{-st} \int_0^t Y(\tau)G(t-\tau) d\tau dt. \quad (43)$$

In the solution of elastic stress analysis problems where the material properties are not in simple form (E^n), the Laplace transform may be applied to the differential equation of the viscoelastic case, thus removing the time variable and leaving an elastic solution. Using the inverse Laplace transform, one can obtain the viscoelastic solution. The Laplace transform need not necessarily be applied to the differential equation. If an elastic solution exists to an equivalent elastic problem, the inverse Laplace transform can be applied almost directly (25). Care must be taken that the spatial distribution in both the viscoelastic problem and the corresponding elastic problem is maintained. This "correspondence" between viscoelastic problems and elastic problems is very important.

EXPERIMENTAL ASPECTS

The most common experiments on viscoelastic materials are as follows:

1. Creep
 - A. Uniaxial tension or compression
 - B. Torsion
2. Stress relaxation
 - A. Uniaxial tension and compression
 - B. Torsion
3. Constant crosshead velocity for different velocities
 - A. Uniaxial tension or compression
 - B. Torsion (constant rate of twisting)
4. Sinusoidal tests where either stress or strain is the independent variable

5. Birefringence tests

All the above can be performed at different temperature and humidity. For an ideal isotropic, linear viscoelastic material, creep, stress relaxation, and constant crosshead velocity yield equivalent information. Knowing the behavior under one situation, the behavior under the other situation can be determined (26, 27).

Creep and stress relaxation experiments cannot be performed for times less than about 1 minute. To obtain data for shorter times, sinusoidal experiments can be utilized. This has a further advantage in that additional decades of time can be obtained. First it should be pointed out that one can use a universal testing machine if one has relatively low capacity load cells and good frequency control. More applicable and less expensive equipment is commercially available for this purpose (28, 29). It is similar to a fatigue tester. (See also ref. (30) for production stress relaxation tests.) The time range for such sinusoidal tests is 10^{-1} to 10^{-4} sec ($10 < \omega < 10^4$); it can be extended to cover 10^3 to 10^{-8} sec. Both the sinusoidal technique and the creep or stress relaxation technique can overlap in their time scales.

In a sinusoidal test, the stress or strain at a particular frequency is the independent variable and the object is to observe the dependent variable. Between the stress and strain there is a lag whose phase angle δ is called the loss angle and is a function only of the frequency ω . The ratio of the maximum stress to the maximum strain is also a function of ω only. The strain (or stress) can be broken up into two parts, one in phase with the other variable, the other 90° out of phase. Therefore, one can construct moduli which are complex, sometimes referred to as dynamic moduli.

The birefringence technique may be used in conjunction with the sinusoidal creep, or stress relaxation experiments to measure the orientation of the

polymer chains. A serious handicap of this technique is that only a few materials have the necessary birefringence properties.

It should be noted again that all of these experiments can be done at elevated temperature, and the time and temperature superposition principle utilized.

Many of the techniques referred to are being utilized at LRL. Robert Jackson (31) is running uniaxial compression creep experiments in which a dead weight is placed on a foam plastic and the axial deformation is measured as a function of time. This is done at several temperatures (Applied Mechanics Laboratory). Stress relaxation experiments have been performed on polyethylene at LRL using an Instron universal testing machine where a constant tensile deformation was applied and the stress measured as a function of time (32).

At Site 300, the Weapons Division has performed many axial compression creep tests on live high explosives.

THE COMBINED STRESS VISCOELASTIC PROJECT AT LRL

The objectives of the research effort in the Support Division are as follows:

1. To experimentally verify the stress-strain (constitutive) relationships for linear viscoelasticity as a function of stress state, temperature, and humidity.
2. To experimentally verify available or new equations that will take account of nonlinearity in stress and strain at different stress states, temperatures, and humidities.
3. To determine whether the arbitrary criterion of failure used on metals at elevated temperature (33) is applicable to plastics.

Much of the experimental equipment for biaxial creep tests at LRL was designed by Findley and Gjelsvik and reported in ref. (19). Further

elaboration of this and additional equipment to be used on this project will be described in a succeeding UCRL report.

The approach taken toward objectives 1 through 3 is to apply biaxial stresses to thin-walled tubular specimens. If an internal pressure is applied to such a specimen, the radial stress is negligible compared with the hoop stress. If in addition an axial tensile or compressive strength is applied, a biaxial state of stress is produced. An internal pressure without any addition of an axial force generates a biaxial stress due to the effect of the pressure in the axial direction. It is extremely important that the wall thickness be uniform so that the tangential stress will not vary around the circumference.

Test Procedure

The approach described above permits producing any stress combination to the right of the σ_t axis. (Fig. 7). If the material is assumed isotropic and homogeneous, the isotropic lines aa' and aa'' can be added. While no such yield surface exists for such materials, it will be the objective then to reach a particular σ_{θ_1} , σ_{z_1} and observe the deformation (axial and tangential) with respect to time. This is to be done until the entire stress space is covered. Checks outside of θ will determine the validity of isotropy. The paths to take to reach σ_{θ_1} , σ_{z_1} will be radial in these experiments and will be traversed at a linear rate (see Fig. 8), with $P_i(t)/P_z(t) = K$ for all tests. For one particular point, the effect of changing K to reach σ_{θ_1} , σ_{z_1} , as well as the path taken, will be investigated.

Thin-walled tubular specimens will be subjected to both torsional (shear) and tangential stresses, and the shear, axial, and tangential strains will be observed as a function of time. All of this is to be done as a function of both temperature and humidity. It is anticipated that under each radial path in Fig. 7, five points will be investigated over the linear and nonlinear region.

Small differences in temperature and humidity have much influence on the mechanical properties of polymers. Figure 9 indicates the effect of relative humidity on tensile strength for polymethyl methacrylate (PMMA) (13).

McLoughlin and Tobolsky (34) have also shown the effects of humidity on PMMA as shown in Fig. 10.

Because of the influence of temperature and humidity, a special (applied mechanics) laboratory was built at LRL with temperature controlled to $73.4 \pm 1^\circ\text{F}$ at a relative humidity of $50 \pm 1\%$.

The material selected for this investigation, polymethyl methacrylate (PMMA), is sold under the trade names Lucite and Plexiglas. The reasons PMMA was selected are as follows:

1. Much information is already available on PMMA.
2. It is linear over a usable range of stress and strain, but under large enough strains it is nonlinear.
3. Designers are using linear viscoelastic theory, including the time-temperature superposition principle.
4. PMMA is compatible with aluminum. Aluminum particles (Reynolds 400 XF) averaging 7 microns and varying from dust to 25 microns are to be mixed with PMMA (50% by weight). This material is to be investigated as thoroughly as plain PMMA. The objective here is to determine the effect on the constitutive equations of a time-independent material embedded in a time-dependent material such as high explosives.

The molecular structure of PMMA is shown in Fig. 11. The glass temperature of PMMA, T_g , is 378°K . If the temperature is below T_g , the creep phenomenon does not depend significantly on molecular weight provided that the molecular weight is above some particular value. This minimum value of

molecular weight for PMMA is not known. Authorities agreed, however, that the higher the molecular weight the better the creep behavior. Nielsen (35) has stated $Z_c = 208 = 2M_c/M_0$, where M_c is the critical molecular weight and M_0 is the molecular weight of the monomer unit. The repeating unit in a polymer is known as a monomer (see Fig. 12). A linear polymer is made up of adding many monomers in a chain. The monomer content of a polymer is the number of monomers that are not tied into the chain. Therefore for good creep resistance it is desirable to have a polymer with a low monomer content.

All specimens are being made from the same batch of PMMA. The monomer content and the number average/weight average molecular weight distribution will be reported. The material is being prepared by Monsanto Chemical Co., in Dayton, Ohio.

Tobolsky (1, 36) has investigated the effect of annealing PMMA (Fig. 13). This gives us an idea of the effect of crazing, in which small microcracks suddenly appear in the material. It is not known how or why they occur. In view of Fig. 13 a cooling rate of 5°C/hour from 120°C is to be utilized prior to testing.

Review of Some of the Literature Available on PMMA

Figure 14 shows stress relaxation versus time (34, 37). The stress at a particular time t is divided by the initial constant strain and the ratio plotted against time. The time-temperature superposition principle is valid for PMMA so in Fig. 14 Tobolsky has divided the curve into several distinct parts as follows (where ϵ is constant and a few percent in magnitude):

Region A. Time effects not pronounced. Not sensitive to molecular weight.

Dependent on annealing rate.

Region B. Linear viscoelastic region. Sensitive to time and temperature.

Not sensitive to molecular weight above critical molecular weight.

Region C. Transition region to rubbery flow.

Region D. Rubbery flow.

As shown in Fig. 14, the primary linear viscoelastic area is between 95 and 113°C. While military requirements are -65 to +165°F, to observe the linear viscoelasticity phenomenon one should go to 234°F (112°C). This linear viscoelastic region is seen again in Nielsen's work (35) on PMMA using sinusoidal techniques (Fig. 15).

On the basis of the work of Marin and Pao (38) and Staverman and Schwarzl (5), linearity in PMMA occurs at room temperature below 1420 psi = 10^8 dynes/cm² stress or 0.01 in./in. strain.

At room temperature, quite nonlinear and very time dependent results are obtained for PMMA. Not only is almost all of the strain nonlinear, but it appears to be nonrecoverable (see Figs. 16 and 17). This is often referred to as the plasticity effect in polymers.

Sherby and Dorn (39) in 1957 showed that PMMA for large values of strain (200%) in the temperature region $-10^\circ\text{C} \leq T \leq 140^\circ\text{C}$ is entirely anelastic (completely recoverable) when the load is removed and the specimen is subjected to further increase in temperature. Without further increase in temperature, permanent strain can exist as was observed by Marin and Pao (38) at room temperature (Fig. 17); it appears that if time went to infinity the material would not recover. Permanent strain can exist in nonlinear deformation at any temperature, in addition to the viscous effect (ϵ_3) associated with linear viscoelasticity. At room temperature there is no viscosity effect in the linear region due to linear viscoelasticity.

The effect on tensile strength as a function of crosshead speed is given by Bartoe and reported by Dietz et al.(40) for PMMA. Data on other features of the behavior of PMMA are reported by Knowles and Dietz (41). Thermal expansion for PMMA is given by Sherby and Dorn in ref. (39).

SUMMARY

It has been shown that for viscoelastic materials the interrelationship between stress, strain, time, and temperature makes stress analysis more difficult than for elastic materials. Several approaches to linear viscoelastic stress analysis have been discussed. These are:

1. Solving the differential equation for the appropriate model.
2. Using the appropriate empirical constants.
3. Relating time to temperature.
4. Transforming viscoelastic analysis into equivalent elastic analysis with the Laplace transform.

All of the methods require experimentally determined constants and a fairly sophisticated mathematical treatment.

It has been shown that little theory exists and essentially no experimental work has been done in the nonlinear region of viscoelasticity. The same status of limited theory and virtually no experimental work exists in the area of multi-axial viscoelastic stress fields. The experimental projects at LRL are undertaken to contribute in the areas mentioned above, i. e.,

1. Criteria for failure for viscoelastic analysis.
2. Experimental data to verify existing theories or to guide development of a new theory that will include nonlinear viscoelastic stress fields as a function of temperature and humidity.

Acknowledgments

Grateful acknowledgment is given the following LRL personnel for their help: to Jay Lepper (Process Materials and Development), for his assistance in processing the material; to Robert Jackson and Robert Westbrook (Support Division), and Wallace Clements (Technical Information Division), for reviewing the manuscript. The many helpful comments and suggestions of Prof. William Findley (Brown University) are greatly appreciated.

This work was done under the auspices of the U. S. Atomic Energy Commission.

REFERENCES

- (1) A. V. Tobolsky, "Properties and Structures of Polymers," John Wiley & Sons, New York (1960).
- (2) E. A. W. Hoff, "Some Mechanical Properties of a Commercial Polymethyl Methacrylate," Journal of Applied Chemistry, Vol. 2, p. 441 (1952).
- (3) R. V. Churchill, "Fourier Series and Boundary Value Problems," McGraw-Hill Book Company, Inc., New York (1941).
- (4) H. A. Stuart, "Die Physik Der Hochpolymeren," Band IV, Springer-Verlag, Berlin (1956).
- (5) F. Schwarzl and A. J. Staverman, "Time-Temperature Dependence of Linear Viscoelastic Behavior," Journal of Applied Physics, Vol. 23, No. 8, p. 838 (1952).
- (6) Annual Meeting of Society of Rheology, Johns Hopkins University, November 1-3, 1962.
- (7) W. N. Findley, "The Effect of Temperature and Combined Stresses on Creep of Plastics," Second International Reinforced Plastics Conference, sponsored by The British Plastics Federation, London, England, December 1960.
- (8) R. Muki and E. Sternberg, "On Transient Thermal Stresses in Viscoelastic Materials with Temperature-Dependent Properties," Journal of Applied Mechanics, Vol. 28, p. 193 (1961).
- (9) L. Finnie and W. R. Heller, "Creep of Engineering Materials," McGraw-Hill Book Co., Inc., New York (1959).
- (10) W. N. Findley and G. Khosla, "Application of the Superposition Principle and Theories of Mechanical Equation of State, Strain, and Time Hardening to Creep of Plastics under Changing Loads," Journal of Applied Physics, Vol. 26, No. 7, p. 821 (1955).

- (11) R. J. Roark, "Formulas for Stress and Strain," McGraw-Hill Book Co., Inc., New York (1954).
- (12) J. D. Ferry, "Viscoelastic Properties of Polymers," John Wiley & Sons, Inc., New York (1961).
- (13) T. Alfrey, Jr., "Mechanical Behavior of High Polymers," Vol. VI, Interscience Publishers, Inc., New York (1948).
- (14) F. R. Eirich, "Rheology - Theory and Applications," Vol. II, Academic Press, Inc., New York (1958).
- (15) R. A. Westmann, "Introduction to Viscoelasticity," Term Paper, Univ. California, Berkeley, 1960 (Prof. K. S. Pister).
- (16) W. N. Findley and D. B. Peterson, "Prediction of Long-Time Creep with Ten-Year Creep Data on Four Plastic Laminates," Proceedings, Am. Soc. Testing Matls., Vol. 58, p. 841 (1958).
- (17) J. Marin and Y. Pao, "On the Accuracy of Extrapolated Creep-Test Relations for Plexiglas Subjected to Various Stresses," Transactions, Am. Soc. Mechanical Engineers, Vol. 74, p. 1231 (1952).
- (18) K. Onaran and W. N. Findley, "Combined Stress Creep Experiments on Viscoelastic Material with Abrupt Changes in State of Stress," Brown University, Report EMRL-22, December 1962.
- (19) W. N. Findley and A. Gjelsvik, "A Versatile Bi-Axial Testing Machine for Investigation of Plasticity, Creep or Relaxation of Materials Under Variable Loading Paths," Brown University, Report EMRL-19, August 1961.
- (20) E. H. Lee and T. G. Rogers, "Solution of Viscoelastic Stress Analysis Problems Using Measured Creep or Relaxation Functions," Journal of Applied Mechanics, Paper No. 62-WA-18.

- (21) M. I. Rozovskii, "Nonlinear Equations for Creep and Relaxation of Materials in a Complex Stressed State," UCRL Trans. 473(L).
- (22) S. L. Koh and A. C. Eringen, "On the Foundations of Nonlinear Thermo-Viscoelasticity," Perdue University, Technical Report 20, June 1962.
- (23) D. R. Bland, "The Theory of Linear Viscoelasticity," Pergamon Press, New York (1960).
- (24) R. V. Churchill, "Operational Mathematics," Second Edition, McGraw-Hill Book Co., Inc., New York (1958).
- (25) E. H. Lee, "Stress Analysis in Visco-Elastic Bodies," Quarterly of Applied Math., Vol. 13, p. 183 (1955).
- (26) W. N. Findley, "Derivation of a Stress-Strain Equation from Creep Data for Plastics," Proceedings, First U. S. National Congress of Applied Mechanics, 1951, pp. 595-602.
- (27) W. N. Findley, "Prediction of Stress Relaxation from Creep Tests of Plastics," Brown University, Report EMRL-7 (February 1957).
- (28) B. Maxwell, "An Apparatus for Measuring the Response of Polymeric Materials to an Oscillating Strain, ASTM Bulletin, No. 215, July 1956.
- (29) L. E. Nielsen, "Dynamic Mechanical Properties of High Polymers," Society of Plastics Engineers Journal, Vol. 16, No. 5, p. 525 (1960)
- (30) R. J. Curran, R. D. Andrews, Jr., and F. J. McGarry, "Device for Measuring Stress Relaxation of Plastics," Modern Plastics, Vol. 38 No. 3, p. 142 (1960).
- (31) R. J. Jackson, Lawrence Radiation Laboratory (private communication).
- (32) M. Zaslowsky, "The Effect of Radiation on Low Density Polyethylene," UCID-4443 ENS 117, March 19, 1962.
- (33) H. J. Tapsell, "Creep Under Combined Tension and Torsion," Engineering, July 1940.

- (34) J. R. McLoughlin and A. V. Tobolsky, "The Viscoelastic Behavior of Polymethyl Methacrylate," Journal of Colloid Science, Vol. 7, p. 555 (1952).
- (35) L. E. Nielsen, "Mechanical Properties of Polymers," Reinhold Publishing Corp., New York (1962).
- (36) J. R. McLoughlin and A. V. Tobolsky, "Effect of Rate of Cooling on Stress Relaxation of Polymethyl Methacrylate," Journal of Polymer Science, p. 658, September 1951.
- (37) W. N. Findley, "Creep and Relaxation of Plastics," Ch. 8 in "High Temperature Effects in Aircraft Structure," Pergamon Press, New York (1958).
- (38) J. Marin and Y. Pao, "Creep Properties of Lucite and Plexiglas for Tension, Compression, Bending, and Torsion," Transactions, Am. Soc. Mechanical Engineers, Vol. 73, p. 705 (1951).
- (39) O. D. Sherby and J. E. Dorn, "Anelastic Creep of Polymethyl Methacrylate," Journal of the Mechanics and Physics of Solids, Vol. 6, p. 145 (1958), Pergamon Press Ltd., London.
- (40) A. G. H. Dietz, W. J. Gailus, and S. Yurenka, "Effect of Speed of Test Upon Strength Properties of Plastics," Proceedings, Am. Soc. Testing Matls., Vol. 48, p. 1160 (1948).
- (41) J. K. Knowles and A. G. H. Dietz, "Viscoelasticity of Polymethyl Methacrylate - An Experimental and Analytical Study," Mechanical Engineering, Vol. 76, p. 531 (1954). Third Edition.

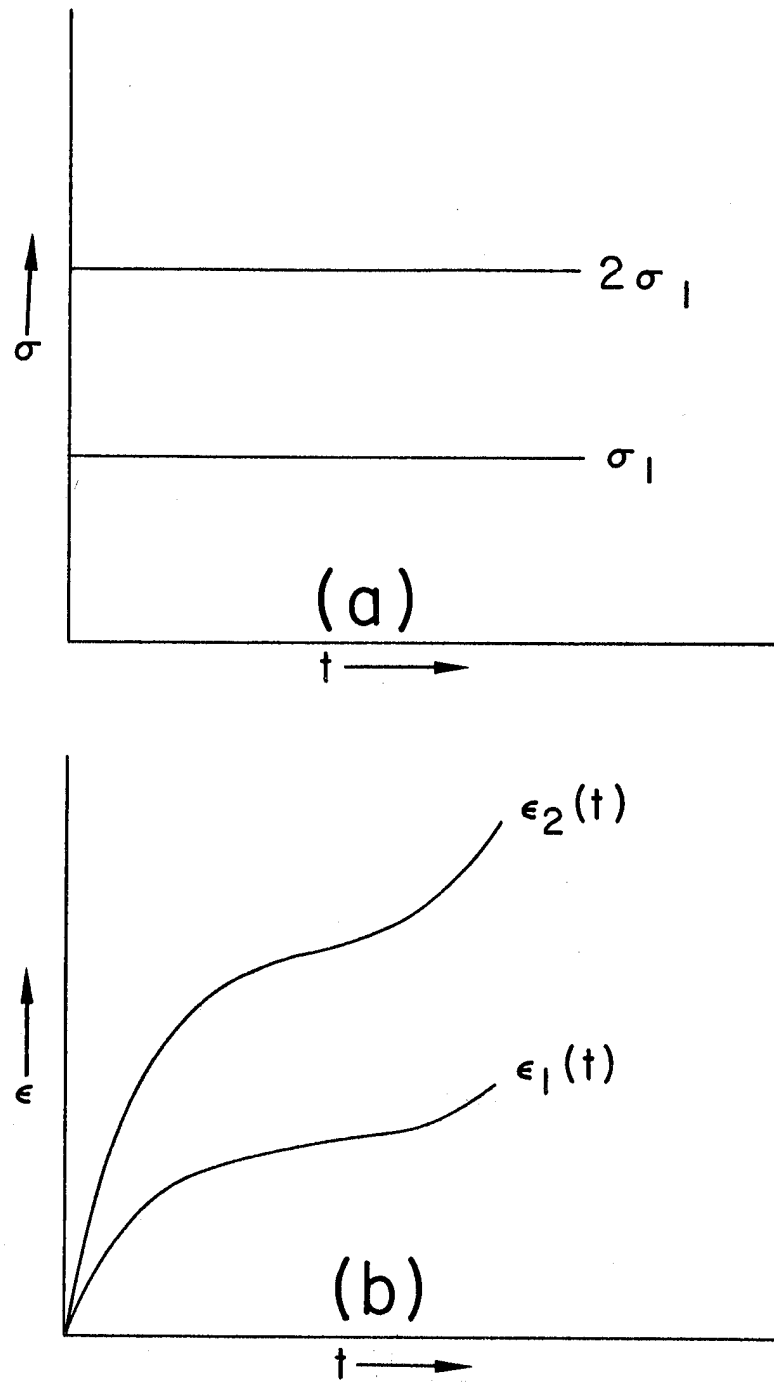

Fig. 1. In viscoelastic material, constant (time-independent) load (a) produces time-dependent deformation (b).

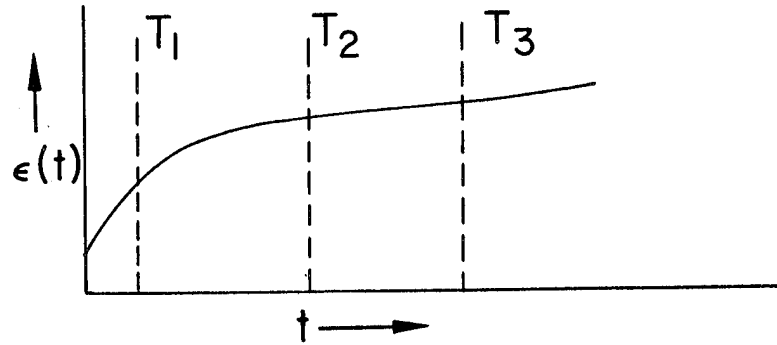

Fig. 2. Time-temperature relation for viscoelastic material.

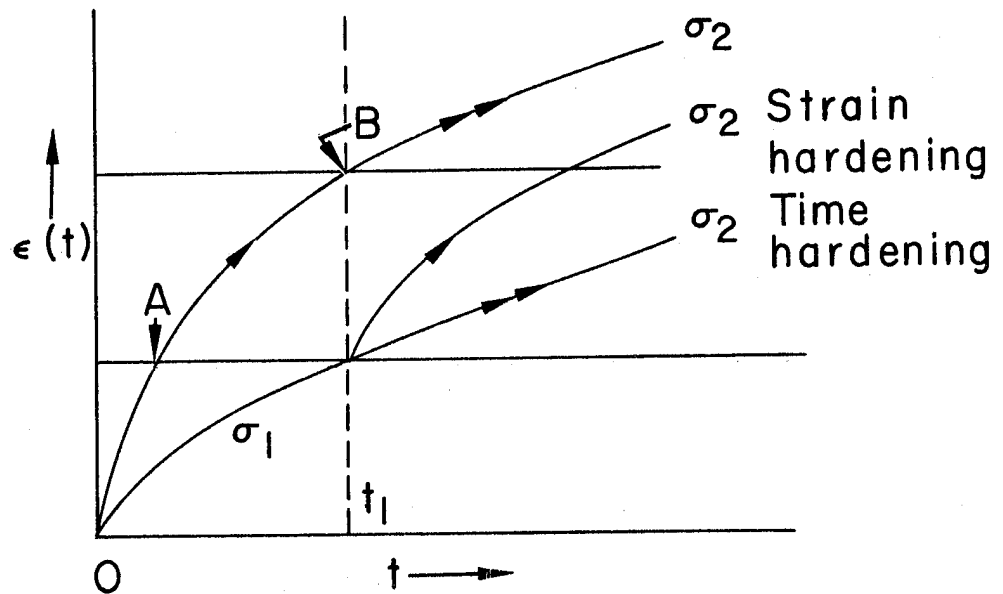

Fig. 3. Illustration of strain hardening and time hardening theories.

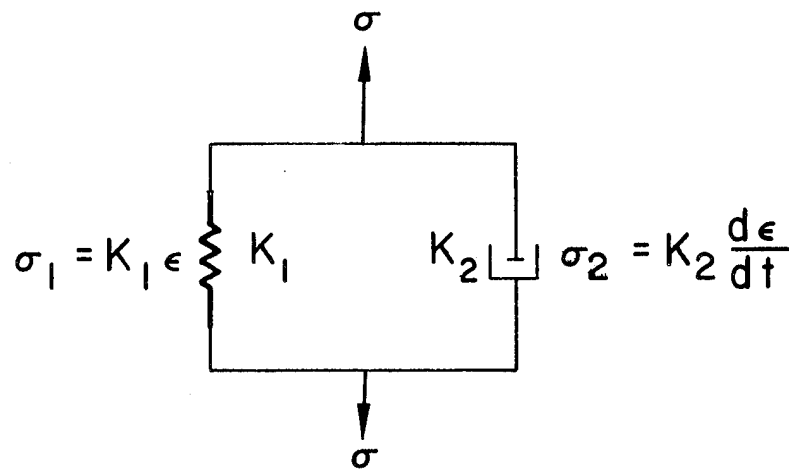

Fig. 4. Kelvin model.

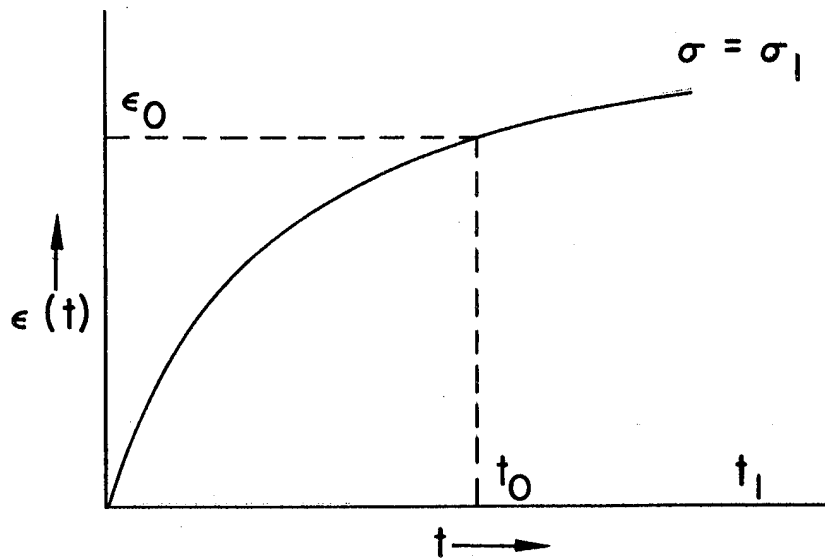

Fig. 5. Typical creep curve.

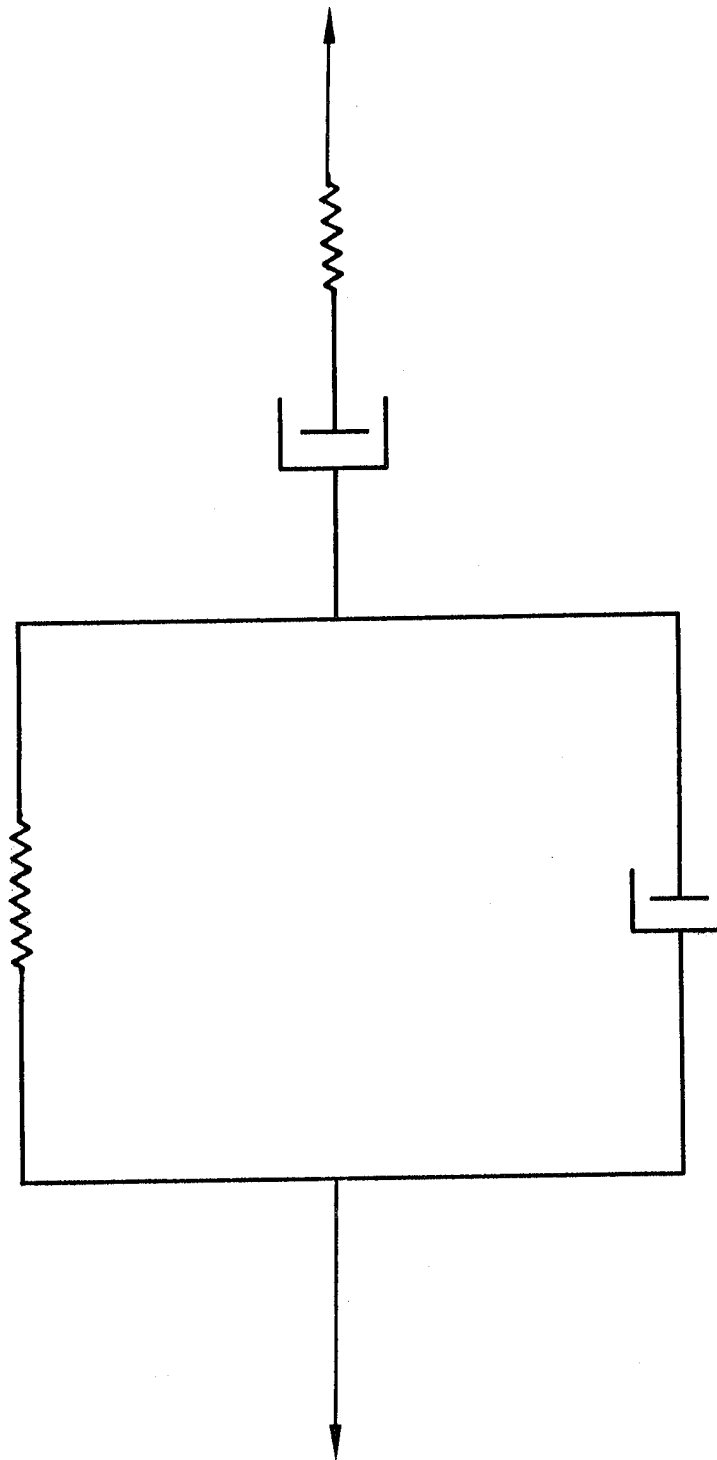

Fig. 6. Burger model, for $\sigma/\epsilon = P/Q$.

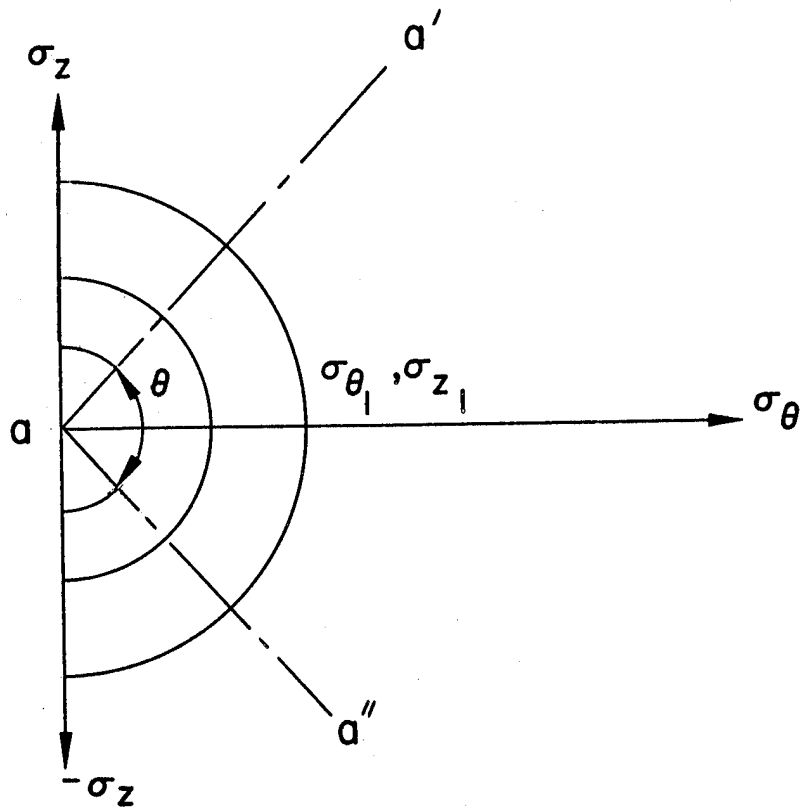

Fig. 7. Two-dimensional stress space.

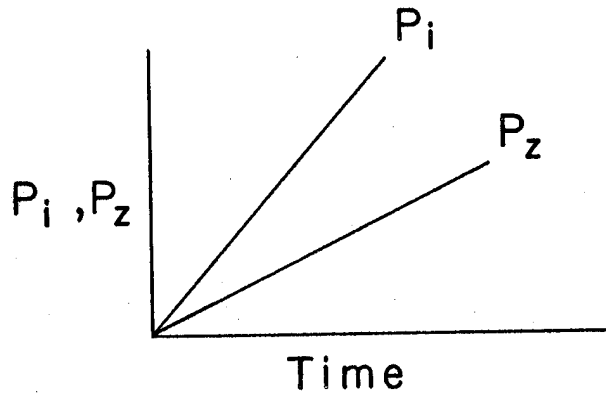

Fig. 8. Internal pressure and axial load control rate.

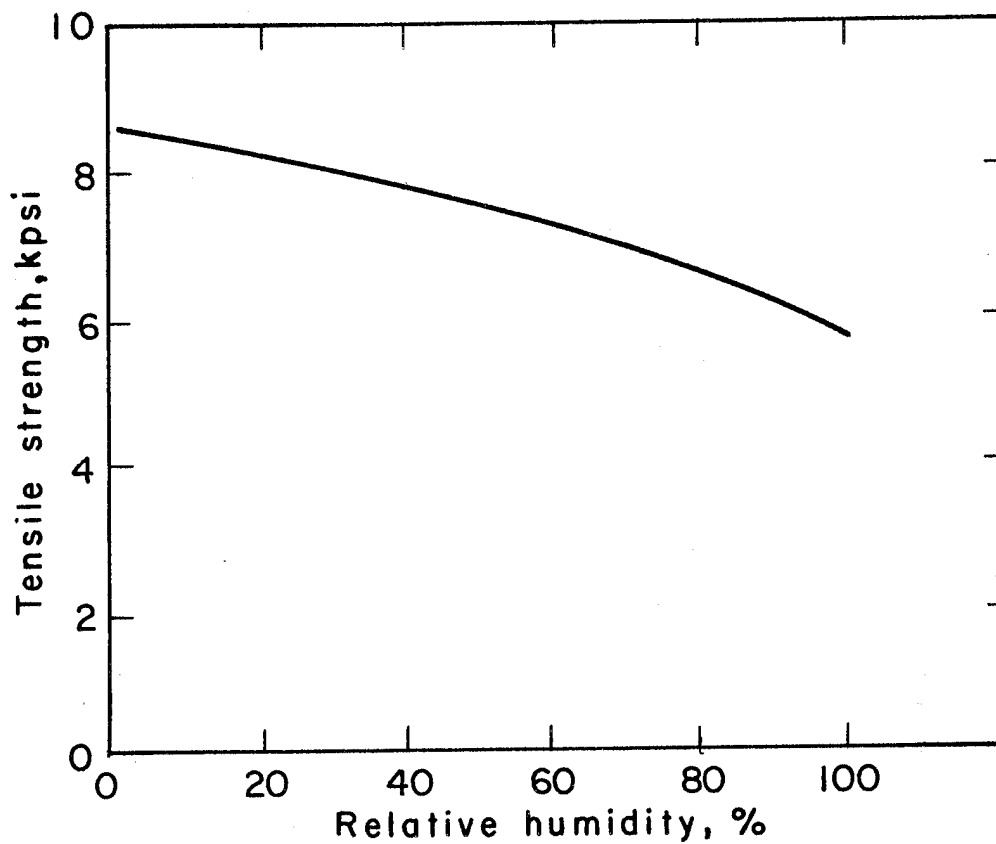

Fig. 9. Effect of relative humidity on tensile strength of polymethyl methacrylate at 77°F. (Courtesy T. Alfrey, Jr., "Mechanical Behavior of High Polymers," Vol. VI, Interscience Publishers, Inc., New York (1948), p. 524.)

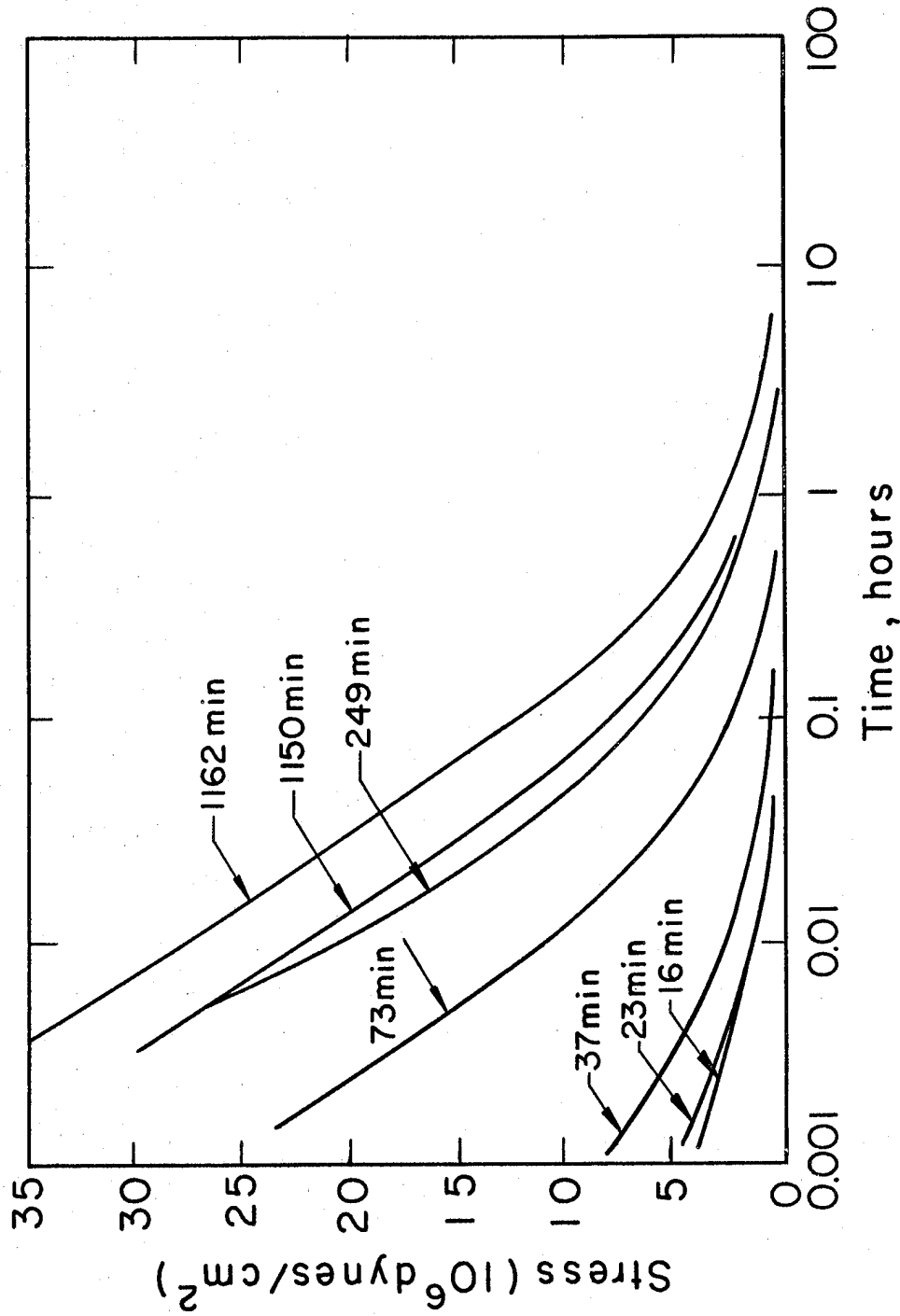

Fig. 10. Effect of water content on stress relaxation of polymethyl methacrylate at 108°C. All runs at same elongation. (Courtesy J. R. McLoughlin and A. V. Tobolsky, Journal of Colloid Science, Vol. 7, p. 555 (1952).)

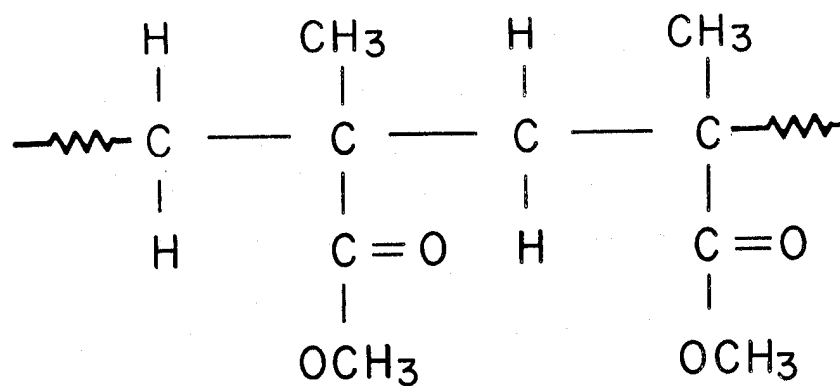

Fig. 11. Molecular structure of PMMA.

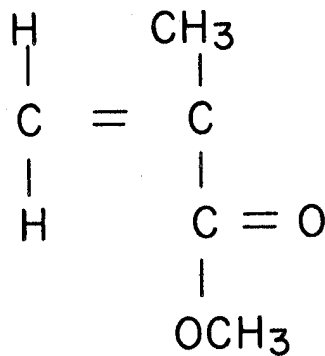

Fig. 12. Monomer unit for PMMA.

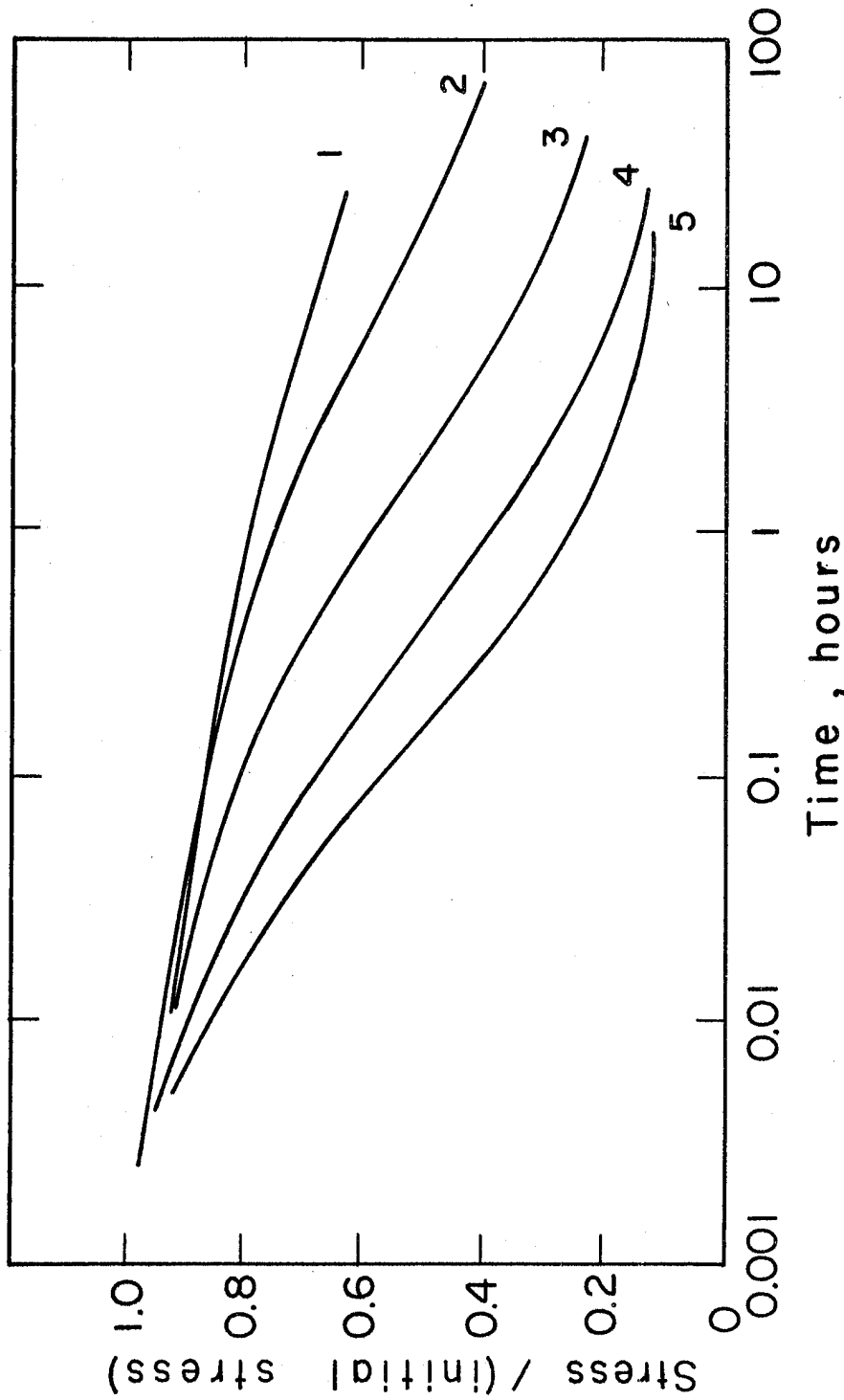

Fig. 13. Effect of cooling rate on stress relaxation of polymethyl methacrylate at 80°C. (1) 5°C/hour, (2) 30°C/hour, (3) convection in 25°C air, (4) plunged in 25°C oil, (5) plunged in naphtha-dry ice bath. (After J. R. McLoughlin and A. V. Tobolsky, *Journal of Polymer Science*, p. 653 (Sept. 1951).)

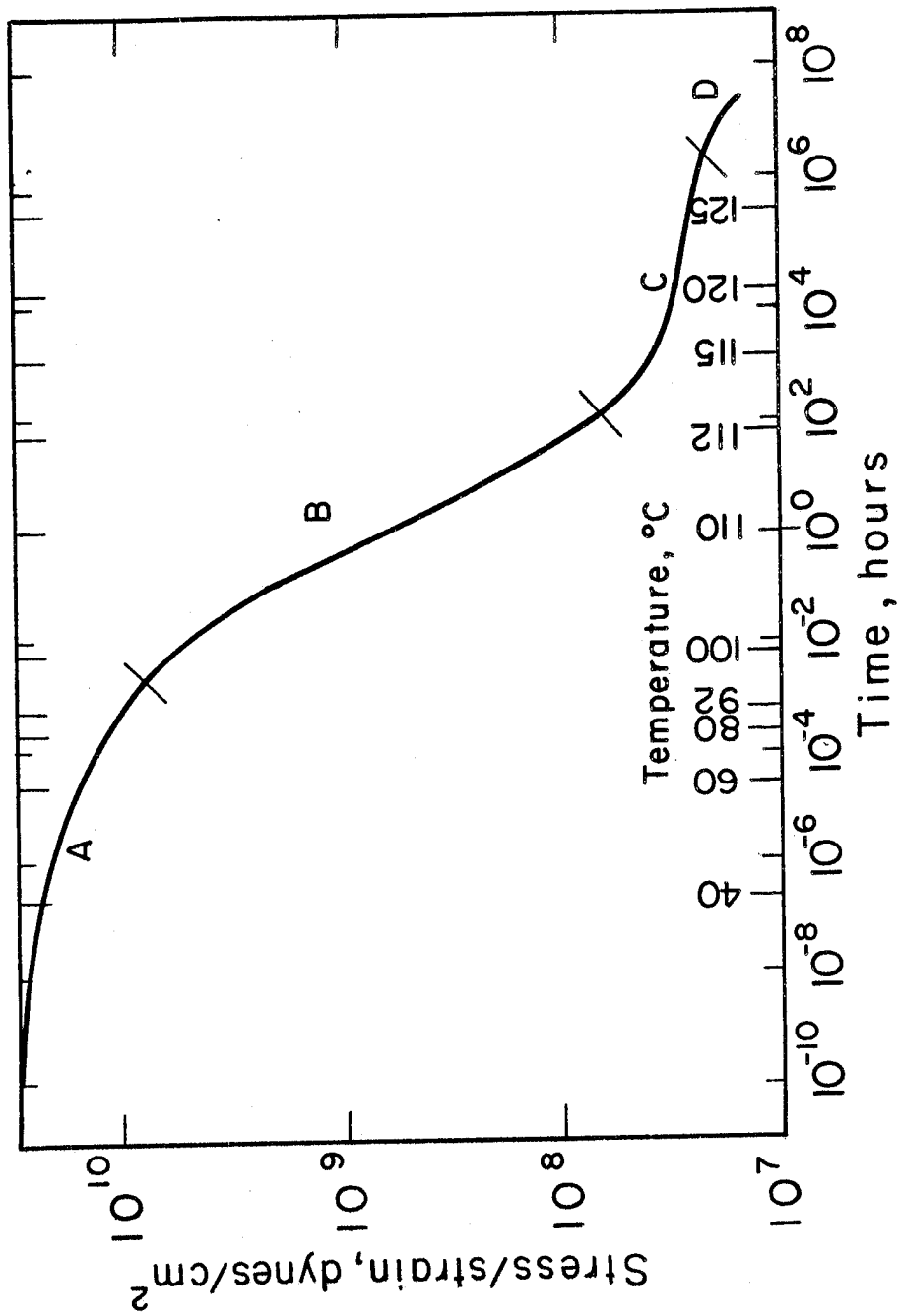

Fig. 14. Composite stress relaxation curve for polymethyl methacrylate. (Courtesy Tobolsky and McLoughlin, Journal of Polymer Science (1952).)

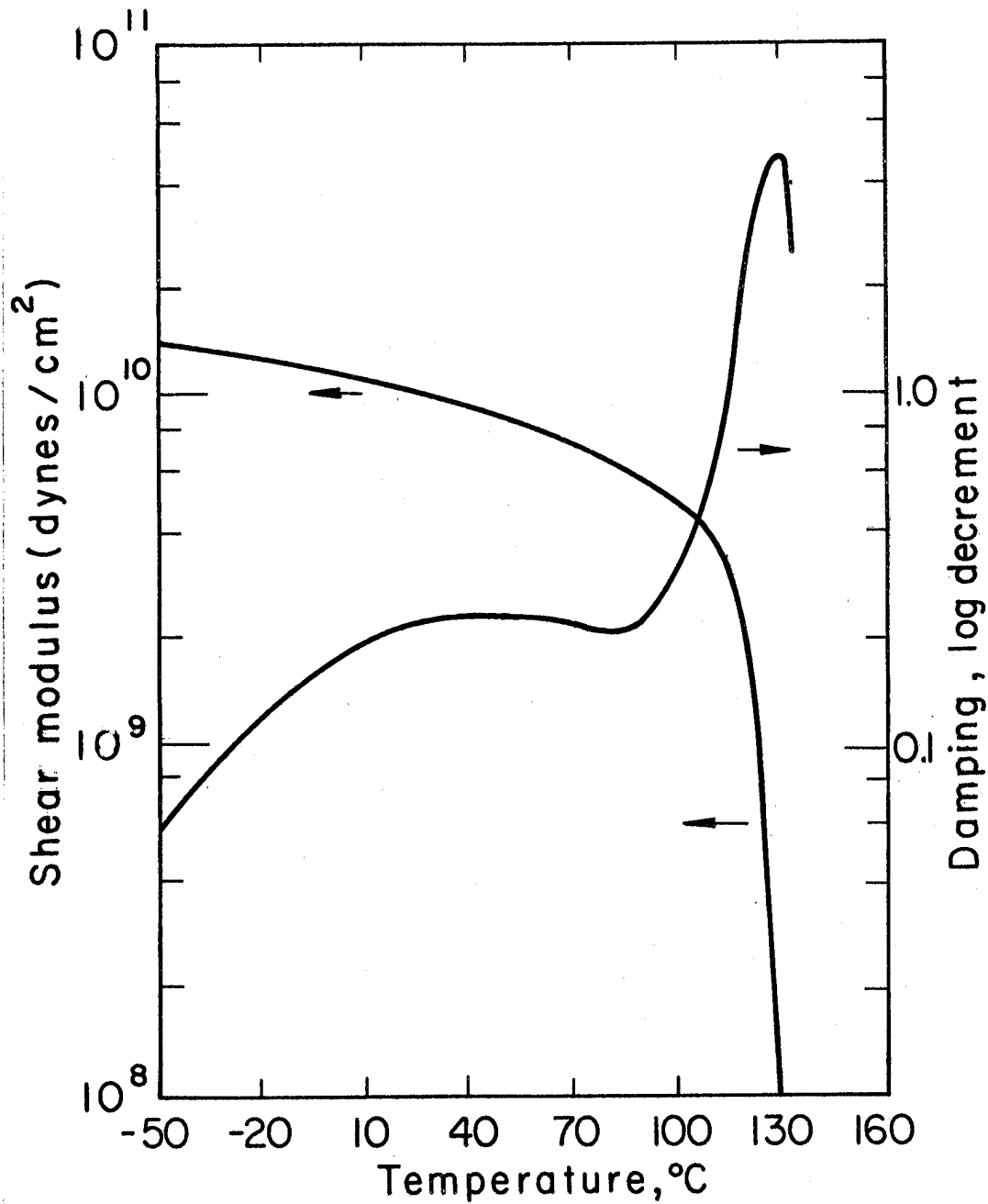

Fig. 15. Dynamic mechanical properties of polymethyl methacrylate. (Courtesy L. E. Nielsen, *Soc. Plastics Engineers Journal*, Vol. 16, p. 525 (1960).)

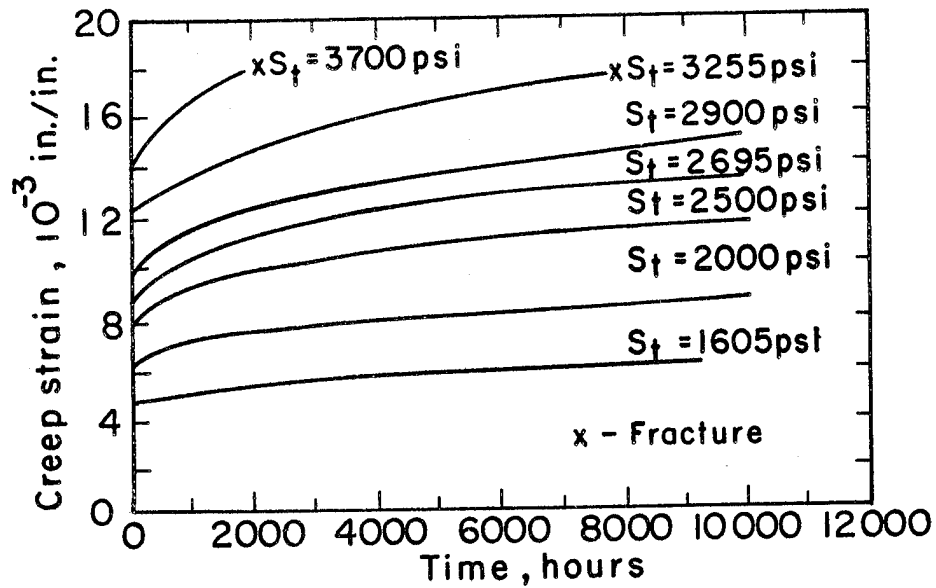

Fig. 16. Tension creep-time relations for Lucite. (Courtesy J. Marin and Y. Pao, Transactions, Am. Soc. Mechanical Engineers, Vol. 73, p. 705 (1951).)

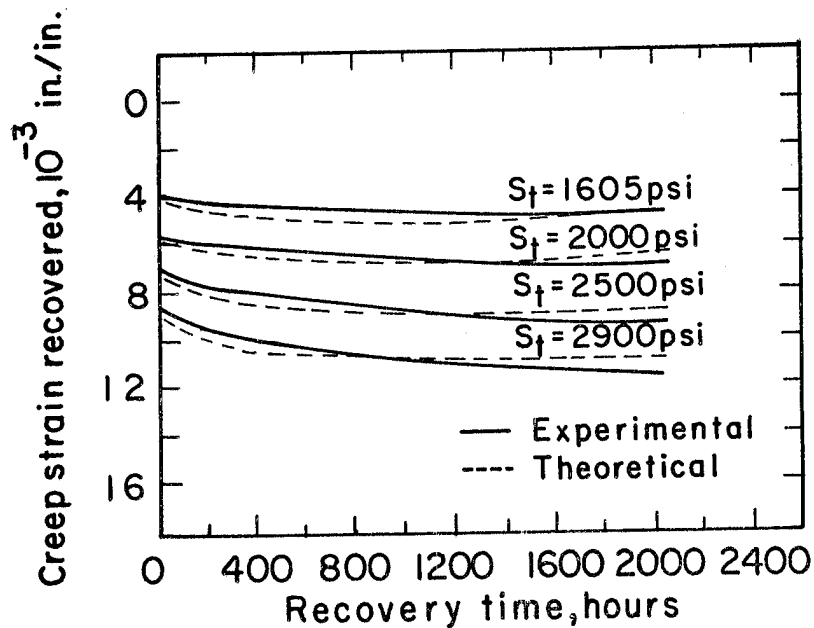

Fig. 17. Tension creep recovery curves for Lucite. (Courtesy J. Marin and Y. Pao, Transactions, Am. Soc. Mechanical Engineers, Vol. 74, p. 1231 (1952).)

LEGAL NOTICE

This report was prepared as an account of Government sponsored work. Neither the United States, nor the Commission, nor any person acting on behalf of the Commission:

A. Makes any warranty or representation, expressed or implied, with respect to the accuracy, completeness, or usefulness of the information contained in this report, or that the use of any information, apparatus, method, or process disclosed in this report may not infringe privately owned rights; or

B. Assumes any liabilities with respect to the use of, or for damages resulting from the use of any information, apparatus, method or process disclosed in this report.

As used in the above, "person acting on behalf of the Commission " includes any employee or contractor of the commission, or employee of such contractor, to the extent that such employee or contractor of the Commission, or employee of such contractor prepares, disseminates, or provides access to, any information pursuant to his employment or contract with the Commission, or his employment with such contractor.