

ADD 406 565

NONDESTRUCTIVE TESTS FOR STRUCTURAL ADHESIVES

Coye T. Vincent, Physicist
Physical Sciences Division

Stanford Research Institute
Menlo Park, California

This is an advance copy of a paper to be presented at the Western Electronic Show and Convention to be held at the Cow Palace, San Francisco, California, August 20-23, 1957.

DEPARTMENT OF DEFENSE
PLASTICS TECHNICAL EVALUATION CENTER
PICATINNY ARSENAL, DOVER, N. J.

RESTRICTION STATEMENT A
Approved for public release;
Distribution Unlimited

UNCLASSIFIED/UNLIMITED

DTIC QUALITY INSPECTED 1

19960424 076

PLASTEC

2081

NONDESTRUCTIVE TESTS FOR STRUCTURAL ADHESIVES*

by

Coye T. Vincent, Physicist
Physical Sciences Division
Stanford Research Institute
Menlo Park, California

*make Abstract
non-destructive tests
in files*

Introduction

The use of high strength adhesives in the fabrication of metal composite structures, is a technique which is coming into extensive use in many fields of design and manufacturing, particularly those related to aircraft. The use of adhesives and adhesive techniques has made it possible to satisfy design requirements that would be extremely difficult or even impossible to satisfy by conventional fastening methods. Since these high strength adhesives are thermosetting in the main, obtaining their ultimate strength at the end of a cure, the quality of these bonds is widely affected by a number of factors. Destructive tests such as tension, compression, and shear tests, together with a specialized test called a "peel test," are widely used. All of these methods determine bond quality by destroying the bond, which has the disadvantage of making the tested assembly unusable. As a result, the evaluation of usable bonded assemblies is based upon rigid process control and random destructive testing of production run parts. These methods are quite satisfactory in some applications. However, there are many applications in which a direct and immediate indication of bond strength of usable assemblies is necessary. Situations in which the adhesive bond contributes to the structural integrity

*The work described herein has been performed under contract AF33(616)-2035 with the Materials Laboratory, Wright Air Development Center.

of aircraft exemplify these applications. [the need for a non-destructive, non-damaging method of bond evaluation has thus arisen] and only with the development of such a method will designers be able to exploit fully the adhesive fastening technique.

The most common fabrication method for aircraft is that using an adhesive bond to fasten two or more pieces of metal. Typical constructions employing this method are lap joints or laminates, and lightweight "honeycomb sandwich" panels of metal facings bonded to metal honeycomb cores. The strength of the "honeycomb sandwich" assembly is dependent upon an adequate core-to-facing bond. Metals and plastics are the usual materials for this assembly. Figure 1 shows examples of lap joint and sandwich construction.

The adhesives used in such applications are complex organic materials. The faying surfaces of the metal pieces must be extremely clean and properly etched. The application of the adhesive requires extreme cleanliness and rigid control of thickness. The cure time, cure temperature, and cure pressure must be held within narrow limits. The state of the art of adhesive bonding does not appear to be sufficiently advanced to allow an analytical approach to the problem of nondestructive testing. Publications indicate, however, that in some cases the service properties of an adhesive bond can be predicted from ultrasonic measurement of the complex elastic modulus^(1,2). The complex elastic modulus is one that includes the effects of viscosity in describing the

1. Dietz, A. G. H., Closmann, P. J., Kavanagh, G. M., and Rossen, J. N. The Measurement of Dynamic Modulus in Adhesive Joints at Ultrasonic Frequencies. Proc. ASTM 50 (1950), 117.
2. Dietz, A. G. H., Bockstruck, H. N., and G. Epstein. Non-destructive Determination of Mechanical Properties and Deterioration of Adhesives. ASTM Spec. Tech. Pub. 138, 1952.

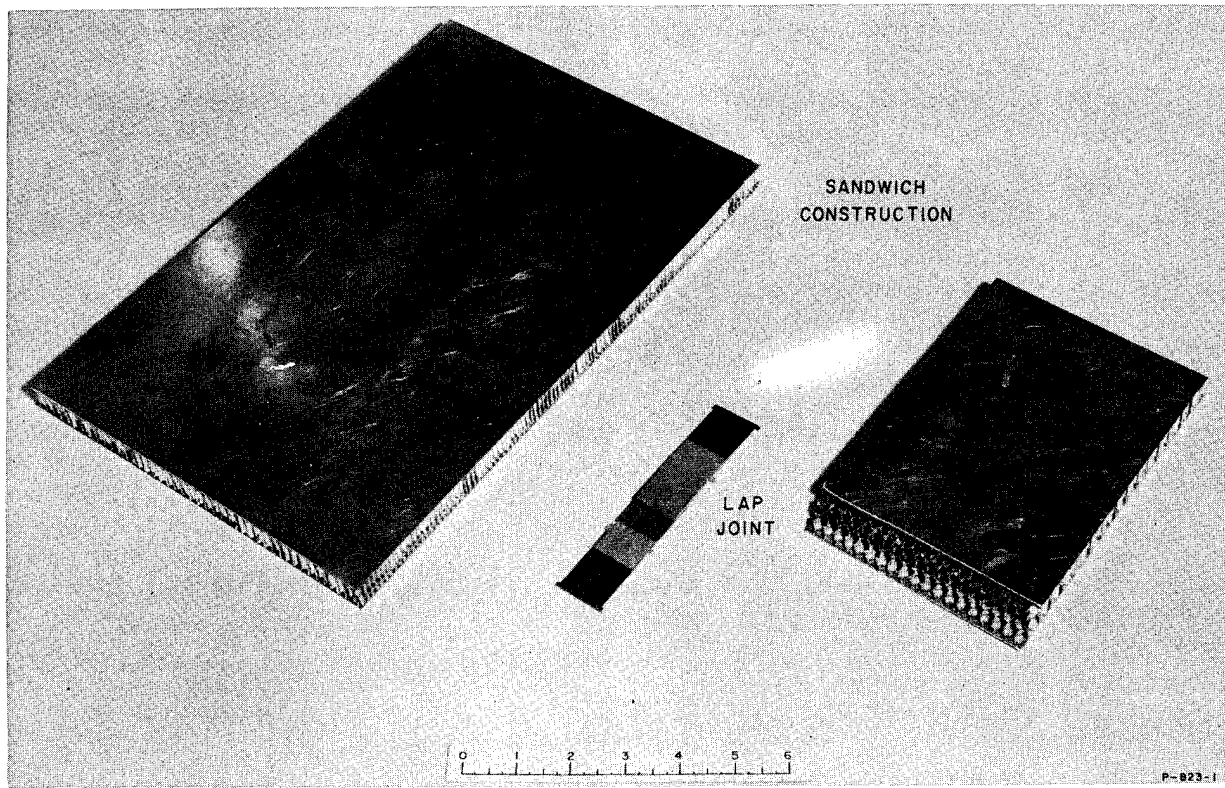

FIG. 1
TYPICAL ADHESIVE BONDED METAL PARTS

stress-strain relationship of a forced oscillating system. The conversion of mechanical to thermal energy (loss) is thus included in the system description.

During an experimental survey of possible usable parameters for bond quality determination, it appeared that this loss parameter was a useful one. The relationship seemed sufficiently close to permit the use of loss observations as a basis of nondestructive bond quality evaluation in most cases, and the exceptions appeared to result from faulty technique rather than nonapplicability of the method.

Apparatus for studying this method has been constructed and is designated functionally as the STUB-meter (STanford Ultrasonic Bond-meter), although this term does not represent any particular circuitry.

Description of Technique

The system under consideration consists of a driving mechanism or transducer tightly coupled to a workpiece or test specimen. The transducer is electrically excited and transforms a part of the electrical energy into mechanical energy. It transmits this mechanical energy as vibrations through the couplant into the test piece. It is evident that the vibrational characteristics of the system as a whole are determined by the electrical properties of the driver, the mechanical properties of the driver, and the mechanical properties of the test piece. The mechanical system can be characterized by its mass, stiffness, and losses, and these quantities are individually made up of contributions from the driver, the test piece, and the couplant used between them. The electrical behavior of the system is related to the mechanical behavior by means of a transformation factor³, which permits the electrical measurements of the system to be considered as representative of the mechanical system.

3. Hueter and Bolt. Sonics. Chapter 4. John Wiley and Sons, New York, N.Y., 1955.

In the STUB-meter technique, the system is continuously supplied with vibrational energy and the system behavior is examined as a function of the driving frequency. The mechanical resonances of the system are of particular interest. Driving frequencies are chosen which are outside the resonances of the test piece, so that the mechanical resonances observed will be those of the driver only. These spectra of resonances of the driver may be catalogued by exciting the driver when it is freely oscillating in free air. The amplitude and frequency of these resonances will change when the driver is tightly coupled to the test piece. These changes are caused by the mass, stiffness, and losses of the test piece. The effects of the contributions are shown by the idealized resonance curves of Figure 2. Changes in the mass and stiffness of the system affect the frequency of the resonance curve, whereas the changes in loss affect the amplitude of the resonance.

The effects of the presence of adhesive bonds in the test piece are to be found in these mass, stiffness, and loss parameters. If a test piece made of two members with an adhesive layer between them is considered, the bond or no-bond conditions are determinable from mass and stiffness considerations. In the no-bond case, the mass and stiffness of the outer member only are added to the system; but in the bond case the mass and stiffness of the complete test piece are in the system. Assuming that a bond is present in the test piece, the quality of the bond may not be determined from mass and stiffness considerations alone.

The change in system losses, however, may be indicative of bond quality. The losses in the system are related to the visco-elastic properties of the materials that make up the system and are a measure of the mechanical energy that is converted into heat

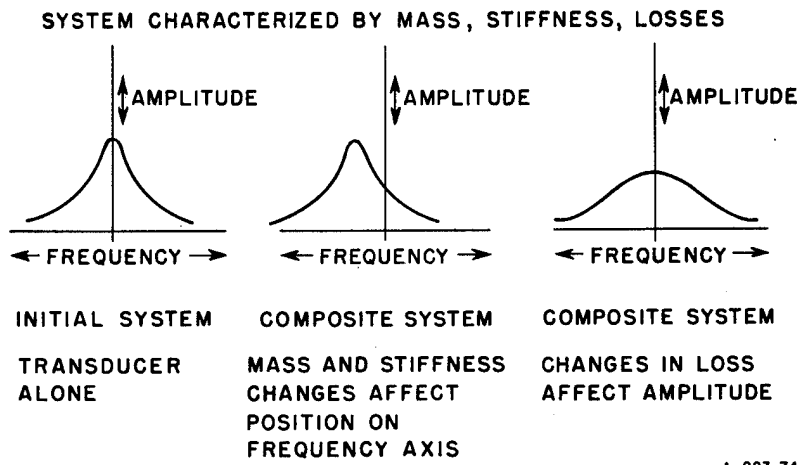

A-823-74

FIG. 2
EFFECTS OF LOADING

by the alternate compression and extension of the system under the forcing vibrations of the driver. The losses of the driver and metal members are small, fixed, and known in terms of their effects, and leave only the loss of the adhesive as a variable. This loss is a characteristic of the physical properties of the adhesive. Variations in the quality of the adhesive bond produce variations in the system losses. Only the loss in that portion of the adhesive actually attached to both members is contributed to the system losses.

The mass, stiffness, and loss behavior of the system can be used as the basis for a comparison method for adhesive bond evaluation. A "standard" adhesive bonded structure is examined by the STUB-meter for its mass, stiffness, and loss characteristics and is then evaluated by destructive tests. The mass, stiffness, and loss characteristics of other specimens of the supposed same construction are then compared to those of the standard, and variations from standard behavior are interpreted as variations in the quality of the adhesive bond. The defects that are encountered in bonding practice affect the test parameters and thus indicate their presence.

The qualitative treatment given above is an extreme simplification of a complex situation. For the single-degree-of-freedom case, the direct analytical approach does not appear to be feasible at present; and it is, therefore, necessary to attack it by experimental study and plausibility argument.

Method of Application

The transducers used in the STUB-meter are barium titanate discs, or short cylinders with fired-on silver electrodes on the flat surfaces. They are polarized axially. Coupling this driver to the test specimen is accomplished by a liquid film of light

mineral oil called the couplant.

When polarized, barium titanate becomes piezoelectric; therefore, when an alternating voltage is applied to the electrodes, the transducer changes its physical dimensions slightly due to the interaction of the electric field with the polarization of the barium titanate crystals. Thus, the transducer vibrates mechanically at the frequency of the electric driving voltage.

The driving voltage is produced by a frequency modulated oscillator and power amplifier. The center frequencies that have been used range from 100 kcps to 1 mcs with up to 100 percent frequency modulation. The transducer is fed from a constant current source. The behavior of the transducer is observed through an amplitude modulation detector with the aid of an oscilloscope whose sweep is locked to the frequency of the frequency modulating voltage. This arrangement allows the response of the transducer to be observed as a function of frequency. Figure 3 is an oscilloscope photograph of a transducer resonance and shows the effects of several types of loading. The horizontal coordinate represents vibration frequency and the vertical component represents the vibration amplitude.

The mechanical behavior of the cylindrical barium transducers is rather complex and results in each transducer having a number of resonances that are not harmonically related. These resonances form a pattern or spectrum of peaks in the frequency ranges in which we are interested. Patterns of several transducers are shown in Figure 4. The patterns of these resonances depend upon the aspect ratio (radius/thickness) of the unit, and its dimensions. Units with the same aspect ratios, although of different frequencies, have the same patterns, or spectra of resonances. An example of this

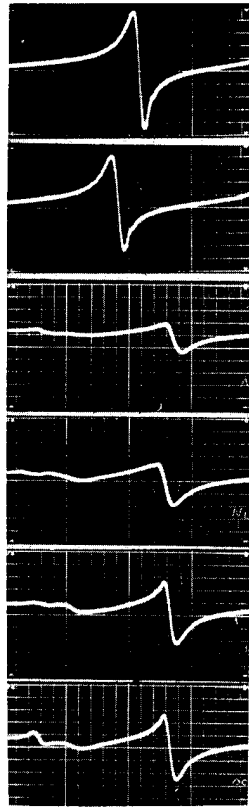

FREE PROBE

PROBE ON SKIN ONLY

PROBE ON LAMINATE
SATISFACTORY BOND

PROBE ON LAMINATE
DEGREASED, BUT NOT
ACID CLEANED

PROBE ON LAMINATE
UNDERCURED BOND

PROBE ON LAMINATE
OVERCURED BOND

P-823-110

FIG. 3
EFFECTS OF LOADING ON TRANSDUCER RESONANCE

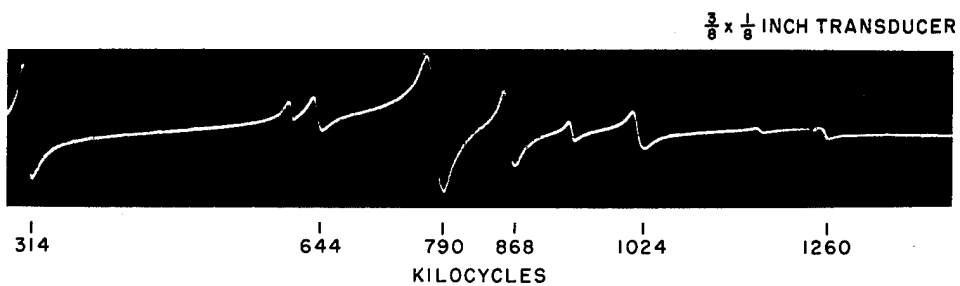
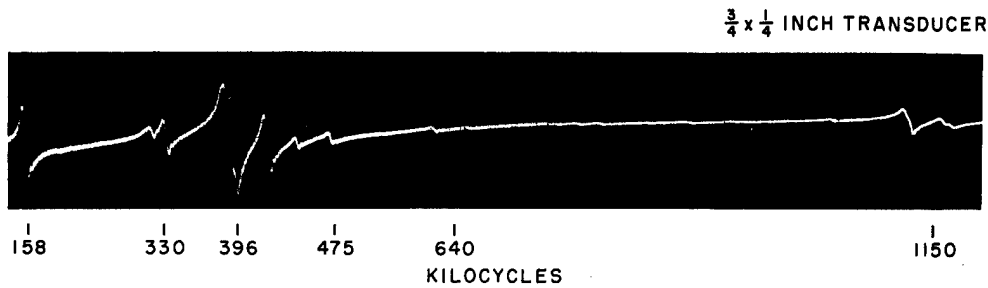

ASPECT RATIO 3:1

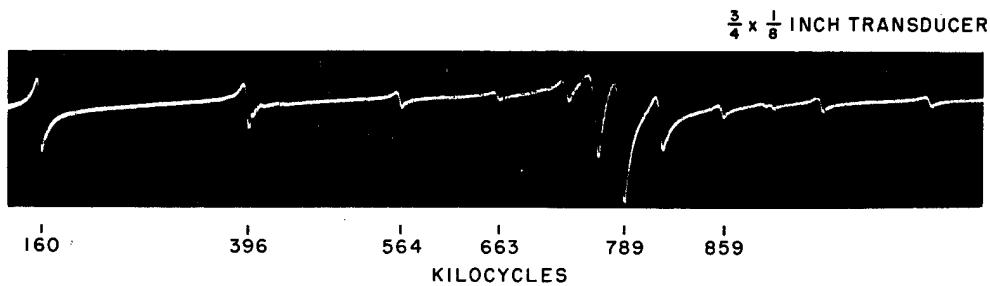

ASPECT RATIO 6:1

P-823-98

FIG. 4
RESONANCE PATTERNS

is shown in Figure 5. Each peak represents a particular mode of vibration, with some of these vibration modes being more useful than others in the bond evaluation problem. Most of these modes are "mixed" in the sense that they cannot be described as purely axial or purely radial. Study of the possible system vibration modes and determination of their usefulness in bond evaluation are current activities in the STUB-meter development.

The relative surface densities (mass per unit area) of the transducer and test piece are quite important to the technique. The amplitude of a particular transducer resonance becomes smaller as the surface density of the test piece is increased. As the density of the test piece is further increased, the resonance almost disappears and a new resonance peak is developed, the amplitude of which is sometimes comparable to that of the original peak. Such behavior is shown in Figure 6. These patterns are termed "primary" and "secondary" patterns. There have been cases in which even "tertiary" patterns have been observed. The primary patterns result from the transducer's contributing a major portion of the system characteristics, and the higher patterns occur when the test piece characteristics become the predominant factor in the system. Both primary and secondary patterns can be useful in bond evaluation, but primary patterns are more useful since they can be more easily recognized and measured with respect to the free probe or probe-skin pattern.

Description of Equipment

Electronics

Figure 7 is a block diagram of typical STUB-meter circuitry⁴.

4. For complete schematic diagrams of the electronic circuits see WADC Technical Report 54-231, Part 4. Wright Air Development Center, Wright-Patterson Air Force Base, Ohio.

1 x $\frac{1}{2}$ INCH TRANSDUCER

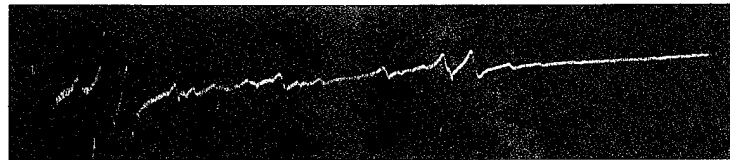

115 200 280 530 600
KILOCYCLES

$\frac{3}{4}$ x $\frac{3}{8}$ INCH TRANSDUCER



153 261 374 597 704 801
KILOCYCLES

$\frac{1}{2}$ x $\frac{1}{4}$ INCH TRANSDUCER

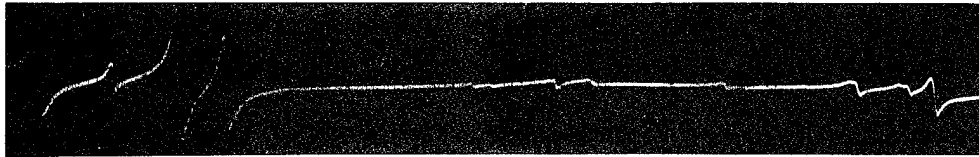

226 315 392 446 885 1355
KILOCYCLES

ASPECT RATIO 2:1

P-823-100

FIG. 5
RESONANCE PATTERNS

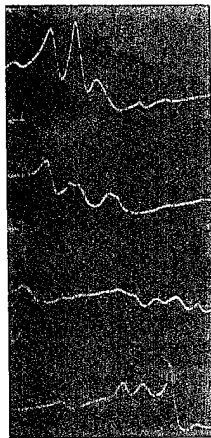

NO LOAD - PRIMARY PATTERN
 1 x $\frac{1}{8}$ INCH TRANSDUCER

LOAD - .011 INCH ALUMINUM
 PRIMARY PATTERN

LOAD - .018 INCH ALUMINUM
 TRANSITION

LOAD - .022 INCH ALUMINUM
 SECONDARY PATTERN

750 600
 KILOCYCLES

A-823-76

FIG. 6
 PRIMARY-SECONDARY PATTERN TRANSITION

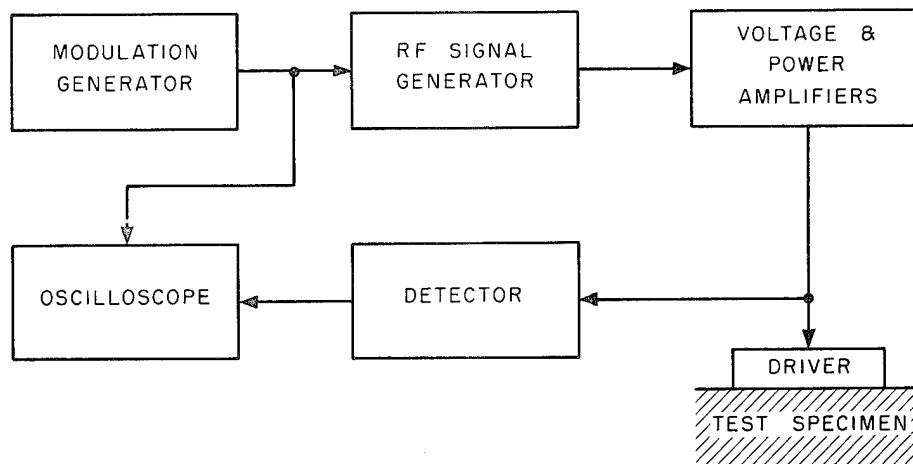

FIG. 7
 FUNCTIONAL BLOCK DIAGRAM OF ULTRASONIC EQUIPMENT
 FOR BOND STRENGTH TESTING

The oscillator provides control of the center frequency and frequency variations of the signal supplied to the transducer. The range of frequencies covered is from 100 kcps to 1100 kcps. The oscillator is capable of being 100 percent frequency modulated with a triangle function. Two types of oscillator circuits have been employed. The first makes use of a saturable reactor as the frequency controlling LC circuit of a modified Colpitts oscillator. The other is an RC oscillator in which the cathode-plate resistance of a set of "control tubes" is utilized to frequency modulate the oscillator.

The modulation generator generates a triangle function of controlled variable amplitude. This is accomplished by successively clipping and amplifying a 60-cycle sine wave to produce a square wave. This square wave is then integrated to give a triangle voltage. The voltage is fed to the saturable reactor of the first oscillator and to the grids of the "control tubes" of the second.

The voltage and power amplifier has a flat frequency response from 30 kcps to 2000 kcps. The power available to the load is 35-milliamperes R. F. current across a 1000-ohm load. The output stage must act as a constant current source of low impedance; therefore, a cathode follower output is used.

The detector is a crystal diode with a resistance-capacitance filter. Its function is to remove the high frequency components and pass only the amplitude modulation or complex wave form that is imposed by the transducer.

A well-regulated power supply is essential.

The output of the detector is fed to the vertical input of a 5-inch cathode ray oscilloscope. A Polaroid-Land oscilloscope camera is provided for making trace photographs of the oscilloscope screen.

Transducers and Transducer Mountings

The function of the transducer is to convert the electrical energy supplied to it into mechanical energy. Barium titanate discs 1/8-inch to 1-inch in diameter and 1/8-inch to 3/4-inch in thickness have been employed in this capacity. Since any constrictive forces placed on the discs by the mountings tend to decrease their sensitivity, the driver is mounted in the probe holder with a flexible adhesive and held against a flexible cushion. The probe holder is made of metal and of a convenient size for easy handling. Conducting paint is used to make a ground connection from the bottom silver electrode to the grounded metal case of the probe. The ungrounded side of the amplifier cable fitting is connected to the barium titanate disc by means of a spring-loaded contact inside the probe.

Couplant

In the use of the STUB-meter, as in other ultrasonic techniques, it is necessary to utilize a liquid film to transmit energy from the driver into the work piece. If no liquid is used, the driver and test specimen are separated by a thin film of compressible air which is a poor transmitting medium. The replacement of air by a liquid medium produces a satisfactory mechanical coupling. The electrical properties of the couplant take no part in the measurements. A good couplant must thoroughly wet the surfaces of both the probe and the test piece, and must have high density and low viscous loss. A certain minimum pressure is required to establish the proper contact between the driver and test specimen. Pressure beyond this point has little or no effect.

Experimental Results and Data Analysis

The limit of usefulness of the STUB-meter is not presently known. Experiments show satisfactory correlation between non-destructive tests and destructive tests, but

in some examples satisfactory correlation was not obtained. Experimental work is presently going on in an effort to determine areas of usefulness of the technique and to define its limitations.

Oscilloscope patterns that result from typical bonds are shown in Figure 3. The amplitude of the individual resonances can be plotted against the ultimate strength of the tested specimen determined by a destructive test. Such a plot is shown in Figure 8. These were honeycomb sandwich panels that had 0.016-inch aluminum skins bonded to aluminum honeycomb core with FM-47 adhesive. They were surveyed with a STUB-meter using a 1 x 1/4-inch probe in the frequency region around 400 kc. Many other graphs similar to this have been obtained, some having more scatter, others having less.

A large number of variables that may or may not affect the results of a STUB-meter survey are involved. These can be separated into two classes: those associated with the test pieces and those related to the STUB-meter; those associated with the test specimen include materials, adhesives, and the geometrical configuration of both of these; those related to the STUB-meter are transducer geometry and the frequency range employed. It may be concluded then that for a given test piece there seems to be an optimum STUB-meter setting.

In order to prove the applicability of the STUB-meter, a program has been established with the cooperation of several aircraft manufacturers. Certain bonded structures fabricated by the manufacturers are destructively tested after having been surveyed with the STUB-meter. These tests provide a consistent group of data for a study of the correlation between destructive and non-destructive tests. Nine laboratory-type STUB-meters have been constructed and placed in aircraft plants. Figure 9 is a photograph of one of

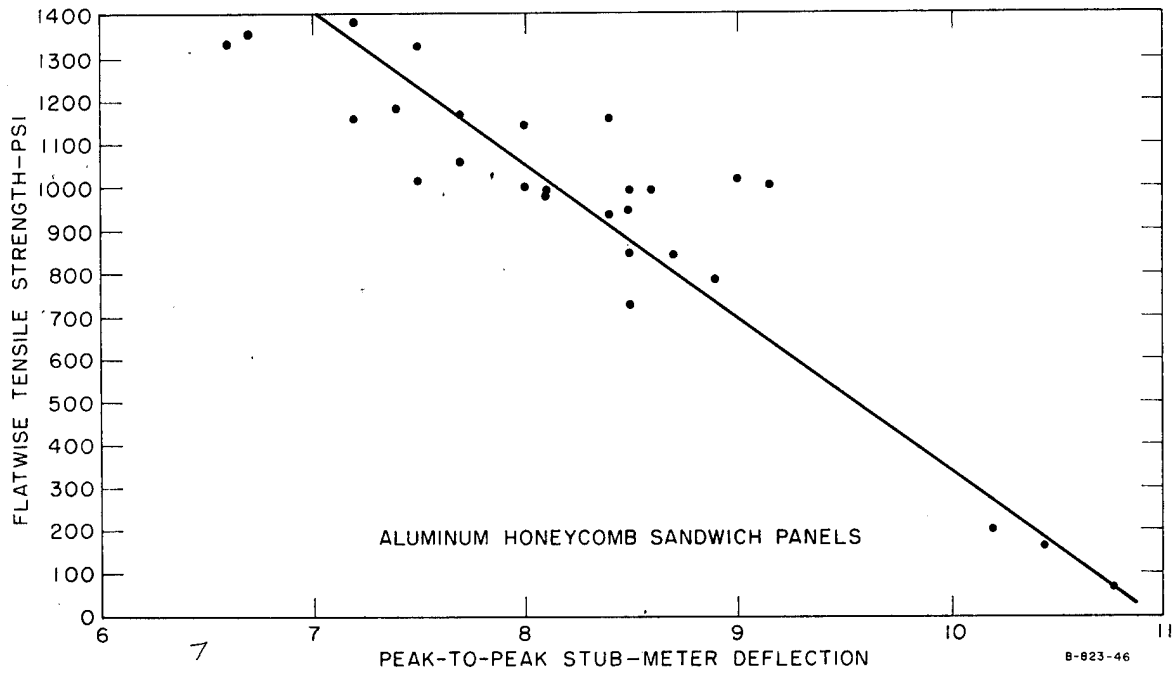

FIG. 8
 STUB-METER DEFLECTION VS FLATWISE TENSILE STRENGTH
 1/8 INCH HEX CELL SAMPLES

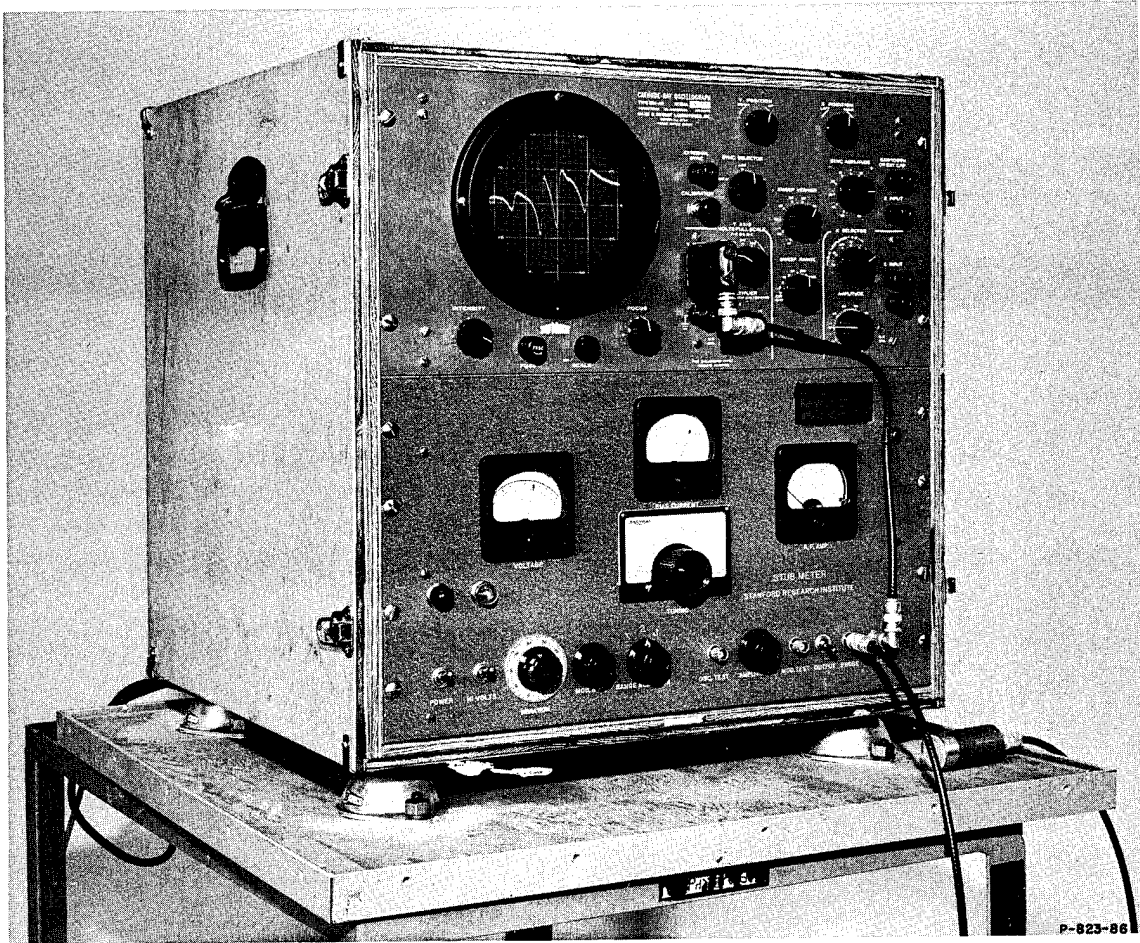

FIG. 9
MODEL 3 STUB-METER

these units. These instruments are supplied with a Polaroid-Land camera for recording the oscilloscope traces. Trace photographs, destructive tests, and test specimen descriptions are sent to SRI, where they are transcribed to punched cards. As soon as a statistically significant body of data is collected, it is analyzed for correlation coefficients. An IBM 650 electronic calculator is utilized to do most of the analysis. The IBM 650 is provided with a program routine which enables it to compute the means, standard deviations, and simple correlation coefficients. The program will handle as many as 33 variables and up to 9999 observations.

A curve-fitting routine has also been devised for the electronic calculator. This programmed routine is called PALS (Polynomial Approximation by Least Squares). It fits a least square polynomial of order n to a set of m weighted observation points, utilizing the orthonormalizing method. The order n may be as high as 100 and m may be as large as 33. The routine gives the coefficients of the approximating polynomials and its residuals, and it can be programmed to stop automatically whenever it reaches a polynomial which has a residual less than a given value.

∩ A correlation plot of shear strength versus STUB-meter amplitude is shown in Figure 10. It consists of data from 244 specimens of 2-ply metal-to-metal laminates 0.020-inch thick bonded with Narmco M3C and MN3C adhesive. They were inspected with a 1 x 1/8-inch probe in the region of 800 kcps. Ninety-two percent of the points fell within the ± 500 psi lines drawn over the points.

Figure 11 is a correlation plot of 84 points from four groups of data obtained from lap shear specimens. The data are normalized to the free-probe pattern and show ∩ frequency shift plotted against shear strength. The computed correlation coefficient

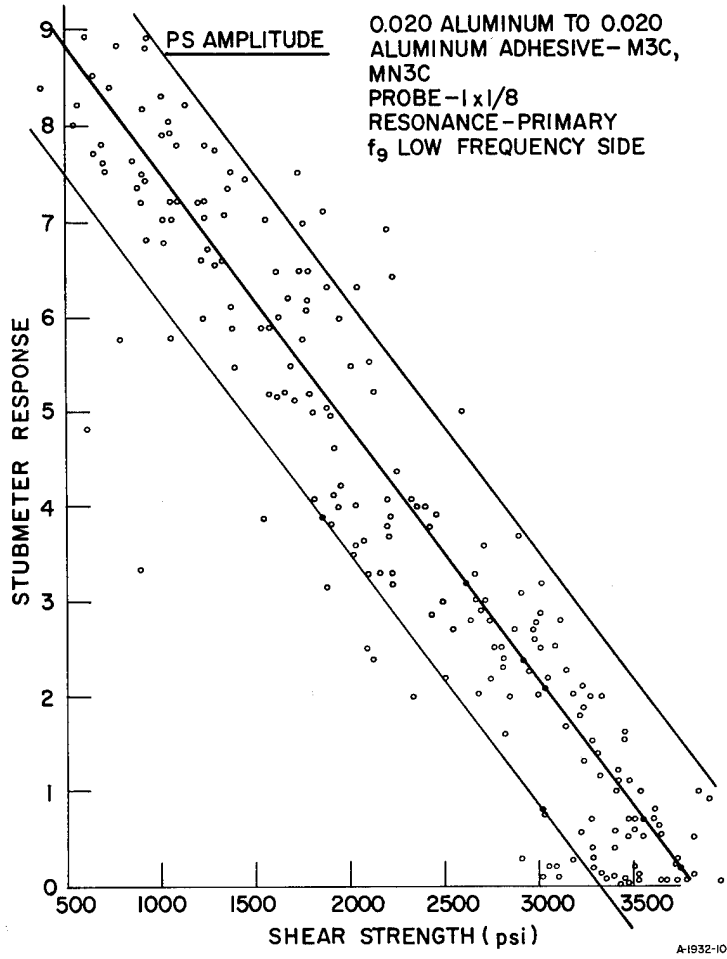

FIG. 10
CORRELATION PLOT
Shear Strength vs STUB Meter Response

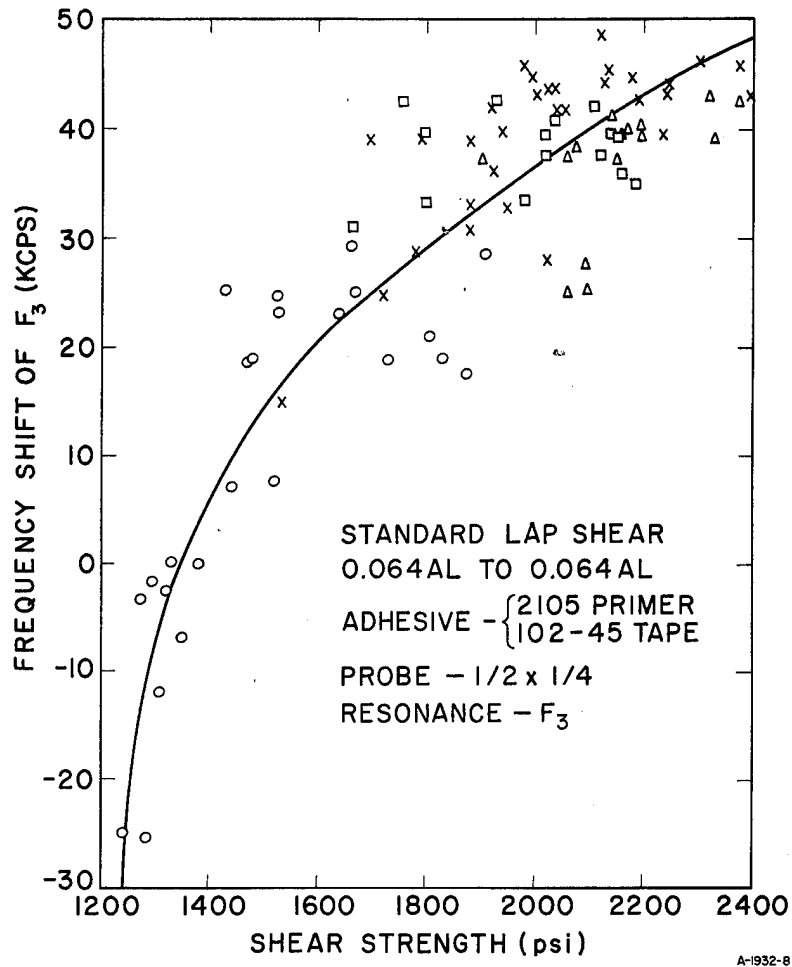

FIG. 11
 CORRELATION PLOT
 Shear Strength vs Frequency Shift

is 0.69. This is on a scale of 1.0 for complete correlation and 0.0 for complete randomness.

Another of the standard destructive tests used by the aircraft industry is the "peel" test. In this test one of the skins of the adhesively bonded piece is "peeled" or rolled up around a drum. The torque producing force is then plotted against its position along the specimen to obtain a "peel record." Such a record is shown in Figure 12 for a laminated test specimen which had three de-laminations measuring 1 inch, 1/2 inch, and 1/4 inch in diameter. The corresponding STUB-meter resonance patterns are shown.

The Model 3 STUB-meter described herein was designed to be used as a laboratory instrument and not intended for use as a production control inspection instrument. It has been recognized that a useful inspection instrument would need to be much smaller and less complex in operation and recording than the Model 3; a "go - no go" read-out would be preferable.

Figure 13 is an example of such simplified apparatus which has been constructed in order to obtain a feeling for the size and shape that such instrumentation might take. No oscilloscope is used in this case; the maximum amplitude of the resonance is read from a one inch meter located in the top of the probe. Screwdriver adjustments are provided for frequency, percent modulation and power output.

This instrument is adjusted, using the more versatile Model 3, to inspect one particular bonded configuration. If the adhesive type, skin thickness, or probe size are changed, new settings of the controls are again made using the Model 3.

The applicability of the STUB-meter to systems other than adhesive bonds has not

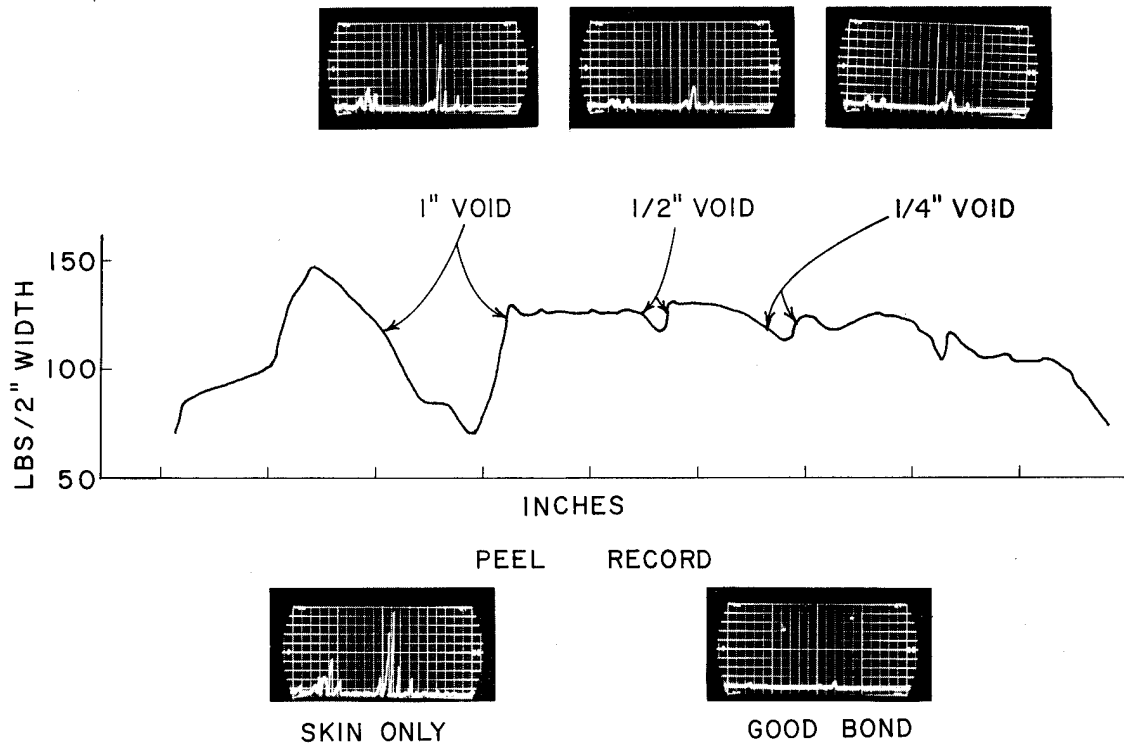

0.016 AL to 0.016 AL

LAMINATE

4021

PROBE 1 X 1/4

A-1932-12

FIG. 12
STUB-METER TRACES AND PEEL RECORD

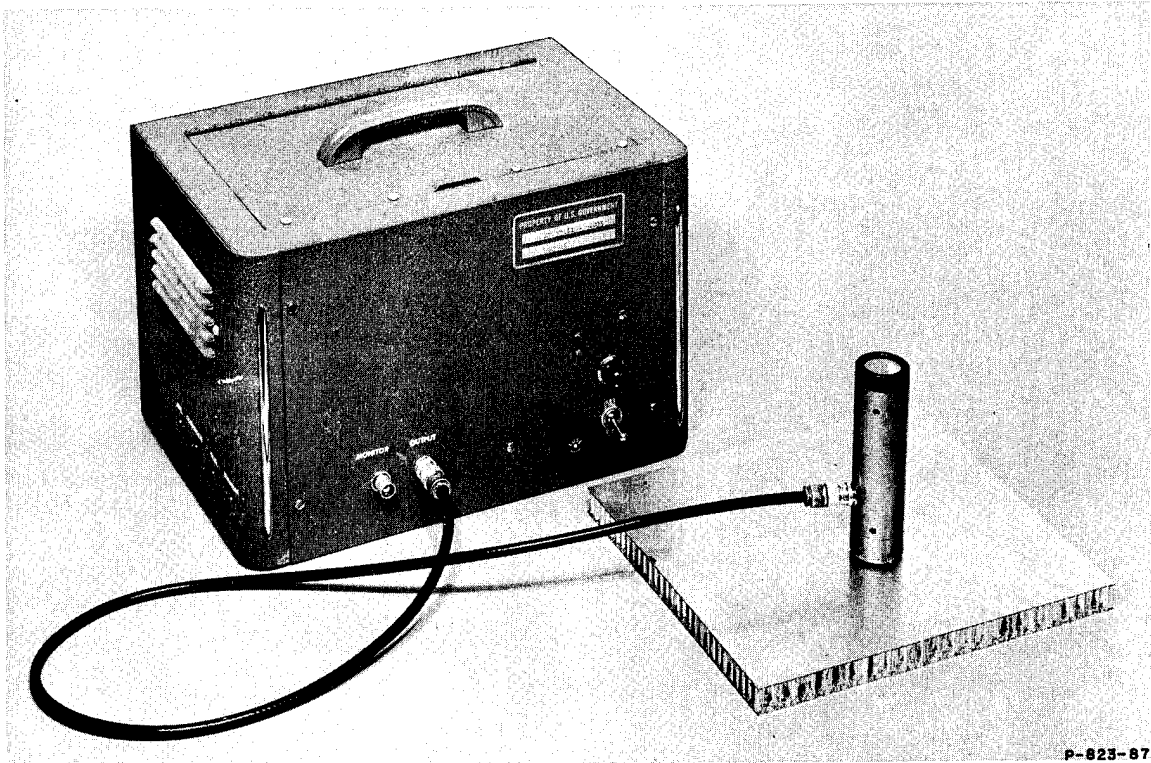

FIG. 13
MODEL 4 STUB-METER

been examined in any detail. Evaluation of plastic laminates and plastic honeycomb is a current activity at SRI. Since adhesive and other bonds are employed in almost every fabrication process, the technique described here may be useful in many other areas.