

ARMY RESEARCH LABORATORY



# Training Effectiveness Evaluation of an MLRS Fire Control Panel Trainer Using Distributed Interactive Simulation

Michael M. Copenhaver  
Harry L.F. Ching  
Linda G. Pierce

ARL-CR-294

MARCH 1996

**prepared by**

CAE-Link Corporation  
Falls Church, Virginia

**under contract**

MDA903-92-D-0039

Approved for public release; distribution is unlimited.

DTIC QUALITY INSPECTED 1

19960502 100

CIMUL8™/SPECT8™/DISIP8™ are trademarks of BDM Corporation.

The findings in this report are not to be construed as an official Department of the Army position unless so designated by other authorized documents.

Citation of manufacturer's or trade names does not constitute an official endorsement or approval of the use thereof.

Destroy this report when it is no longer needed. Do not return it to the originator.

# REPORT DOCUMENTATION PAGE

Form Approved  
OMB No. 0704-0188

Public reporting burden for this collection of information is estimated to average 1 hour per response, including the time for reviewing instructions, searching existing data sources, gathering and maintaining the data needed, and completing and reviewing the collection of information. Send comments regarding this burden estimate or any other aspect of this collection of information, including suggestions for reducing this burden, to Washington Headquarters Services, Directorate for Information Operations and Reports, 1215 Jefferson Davis Highway, Suite 1204, Arlington, VA 22202-4302, and to the Office of Management and Budget, Paperwork Reduction Project (0704-0188), Washington, DC 20503.

1. AGENCY USE ONLY (Leave blank)		2. REPORT DATE March 1996	3. REPORT TYPE AND DATES COVERED Final		
4. TITLE AND SUBTITLE Training Effectiveness Evaluation of an MLRS Fire Control Panel Trainer Using Distributed Interactive Simulation			5. FUNDING NUMBERS PE: 6.27.16 PR: 1L162716AH70 MDA903-92-D-0039		
6. AUTHOR(S) Copenhaver, M.M.; Ching, H.L.F.; Pierce, L.G.					
7. PERFORMING ORGANIZATION NAME(S) AND ADDRESS(ES) CAE-Link Corporation Falls Church, Virginia			8. PERFORMING ORGANIZATION REPORT NUMBER		
9. SPONSORING/MONITORING AGENCY NAME(S) AND ADDRESS(ES) U.S. Army Research Laboratory Human Research & Engineering Directorate Aberdeen Proving Ground, MD 21005-5425			10. SPONSORING/MONITORING AGENCY REPORT NUMBER ARL-CR-294		
11. SUPPLEMENTARY NOTES The contracting officer's representative (COR) is Dr. Linda Pierce, U.S. Army Research Laboratory, ATTN: AMSRL-HR-MF, FT Sill, OK 73503 (telephone 405-442-5051).					
12a. DISTRIBUTION/AVAILABILITY STATEMENT Approved for public release; distribution is unlimited.			12b. DISTRIBUTION CODE		
13. ABSTRACT (Maximum 200 words)  The Depth and Simultaneous Attack (D&SA) Battle Lab and the Fort Sill Field Element, Human Research and Engineering Directorate (HRED) of the U.S. Army Research Laboratory (ARL) collaborated to establish a fire support command and control (FSC2) test bed. The core of the FSC2 test bed is an interface that allows fire support command and control tactical equipment to interact in a seamless manner with computer-generated equipment and forces on the synthetic battlefield. The interface reported in a separate report (Bouwens, Ching, & Pierce, in press) was accomplished using communications protocols that comply with the requirements outlined in the distributed interactive simulation (DIS) protocol data unit (PDU) standards 2.0.3. The objective of this project was to evaluate the FSC2 Test Bed through the conduct of a training effectiveness evaluation (TEE) of a multiple launch rocket system (MLRS) fire control panel trainer (FCPT). In the TEE, soldiers operated the FCPT, which was linked via DIS PDUs to a synthetic environment in which both computer-generated forces and "soldier-in-the-loop" forces interacted in a seamless manner. The training environment supported this test. However, further experimentation is needed to define the advantages, as well as the limits of using the DIS environment to support the development of collective and individual training programs.					
14. SUBJECT TERMS digitization distributed interactive simulation (DIS) fire support			15. NUMBER OF PAGES 95		
			16. PRICE CODE		
17. SECURITY CLASSIFICATION OF REPORT Unclassified		18. SECURITY CLASSIFICATION OF THIS PAGE Unclassified	19. SECURITY CLASSIFICATION OF ABSTRACT Unclassified	20. LIMITATION OF ABSTRACT	

TRAINING EFFECTIVENESS EVALUATION OF AN MLRS FIRE CONTROL PANEL  
TRAINER USING DISTRIBUTED INTERACTIVE SIMULATION

Michael M. Copenhaver  
Harry L.F. Ching  
Linda G. Pierce

March 1996

APPROVED:   
ROBIN L. KEESSE  
Director, Human Research &  
Engineering Directorate

Approved for public release; distribution is unlimited.

U.S. ARMY RESEARCH LABORATORY

Aberdeen Proving Ground, Maryland

# CONTENTS

EXECUTIVE SUMMARY .....	3
INTRODUCTION .....	5
System Description .....	5
Objective .....	7
METHODOLOGY .....	8
Subjects .....	8
Procedure for Testing Students .....	9
Data Collection Process .....	10
RESULTS AND DISCUSSION .....	12
Time Data .....	12
Error Data .....	15
Questionnaire Data from Students .....	16
Questionnaire Data from SMEs .....	18
Human Factors Evaluation of the Physical Characteristics of the FCPT .....	19
CONCLUSION .....	21
REFERENCES .....	23
APPENDICES	
A. Acronym List .....	25
B. MLRS Mission Programs .....	29
C. Biographical Data Collection and Questionnaire .....	67
D. Observational Data Collection Form .....	79
DISTRIBUTION LIST .....	83
FIGURES	
1. Distributed Integrated Simulation System .....	8
2. Desktop Fire Control Panel Trainer .....	13
3. Response Times for Students for each Experimental Simulation Scenario Run ..	14
4. Errors Committed by Students for each Experimental Simulation Scenario Run	16

## TABLES

1. Student Background Data .....	9
2. SME Background Data .....	9
3. Response Time Statistics for All Students Across each Experimental Simulation Scenario Run .....	14
4. Errors Committed by Students for each Experimental Simulation Scenario Run	15
5. Student Responses to Quantitative Questionnaire Items .....	17
6. Students' Responses to the Two Open-ended Questionnaire Items .....	17
7. SME Responses to Quantitative Questionnaire Items .....	18
8. SMEs' Responses to the Nine Open-ended Questionnaire Items .....	20

## EXECUTIVE SUMMARY

Described in this report is the conduct of a training effectiveness evaluation (TEE) of a multiple launch rocket system (MLRS) fire control panel trainer (FCPT) using the distributed interactive simulation (DIS) environment.

Soldier performance data were collected during an assessment of the MLRS FCPT for the U.S. Army Research Laboratory (ARL) and the Depth and Simultaneous Attack (D&SA) Battle Lab at Fort Sill, Oklahoma. Time response data were captured directly from the DIS network via a data logger personal computer (PC). Data were also obtained through observations of task performance accuracy on the trainer. In addition, student questionnaires were completed to assess user acceptance of the trainer as a training device. Questionnaires were also completed by subject matter experts (SMEs) regarding the fidelity of the MLRS FCPT. In addition, SMEs provided time criterion estimates for the selected scenario that soldier trainees performed on the MLRS FCPT. The criterion estimate provided a basis upon which to evaluate trainees' response times. Statistical analyses were conducted on time and error data from soldiers' performance on the MLRS FCPT as well as their responses to the questionnaire items.

The TEE demonstrated that the DIS environment can effectively support simulated training exercises and is capable of supporting automated data collection. Analyses of the data that were collected revealed a clear learning trend; soldiers required significantly less time to complete firing missions with additional scenario runs. On average, soldiers were able to meet the estimated time criterion level of performance after the second scenario run. Soldiers also committed fewer errors with additional scenario runs. Overall, the soldiers had a very positive regard for the trainer in the interactive simulation environment. SMEs also had very favorable comments about the trainer in the simulation environment and encouraged further exploration of future training applications of the DIS.

This effort served as proof of principle that a) a training device can be successfully integrated into a DIS environment together with actual military command and control devices, and b) performance data can be obtained from a training device operating in that environment. Future experimentation is necessary to define the limits of DIS for training, testing, military operations, and research and development.

# TRAINING EFFECTIVENESS EVALUATION OF AN MLRS FIRE CONTROL PANEL TRAINER USING DISTRIBUTED INTERACTIVE SIMULATION

## INTRODUCTION

Economical, effective training is required by today's military. The current revolution in simulation technology provides the means to modify the training strategy of the U.S. Army and improve the readiness of its soldiers, despite current fiscal and environmental constraints. The revolution in simulation technology is being brought about in part through a software technology called distributed interactive simulation (DIS). DIS allows us to create a synthetic, electronic battlefield upon which we can integrate a variety of dissimilar simulations, simulators, and actual military equipment. Described in this report is the technical approach and the results from conducting a training effectiveness evaluation (TEE) of a multiple launch rocket system (MLRS) fire control panel trainer (FCPT) using DIS technology to link live, virtual, and constructive simulations (see Appendix A for a complete list of acronyms).

## System Description

In December 1993, the Depth and Simultaneous Attack (D&SA) Battle Laboratory and the Fort Sill Field Element of the Human Research and Engineering Directorate, U.S. Army Research Laboratory (ARL), with the assistance of the Canadian Aviation and Electronics (CAE)-Link Corporation, successfully linked tactical equipment to constructive simulation models, soldier-in-the-loop simulators, and training devices through the distributed simulation internet (Bouwens, Ching, & Pierce, in press). This network interface to tactical equipment represented the first time that real, unmodified battlefield equipment was interfaced to the synthetic environment using DIS-compatible protocol data units (PDUs). Thus far, the network supports a forward entry device (FED), digital message device (DMD), fire direction data manager (FDDM), and a lightweight computer unit (LCU) running the MLRS fire direction system (FDS) software. This interface can be modified to support other tactical devices or trainers for both training and research and development. Thus, the Army can begin to address, in a cost-effective manner, issues related to doctrine, tactics, materiel, organization, and leadership before committing to doctrinal changes, costly acquisition programs, or extensive reorganizations. In particular, it will permit evaluation of training devices in a simulated battlefield environment while allowing the collection of human performance data in a virtual setting.

The focus of this research project was to examine the extent to which training can benefit from this environment while retaining requirements for achieving established levels of proficiency. The personal computer (PC)-based interface created by the CAE-Link Corporation allowed tactical equipment to interact with other simulations or simulators on the network. CIMUL8™, a force-on-force constructive simulation driver was linked to the tactical devices. Fire missions were transmitted over the network to a MLRS FCPT where the operator performed the missions. In this manner, appropriate targets were engaged by the MLRS and the effects evaluated in the simulation driver. A graphical view of the battle, which used icons to show the location of the various participants and to simulate other friendly and opposing forces, was provided to increase realism and provide training feedback.

In this experiment, CAE-Link scientists tested the capability of the DIS environment by evaluating a prototype training device for the fire control system (FCS) of the MLRS. The MLRS is a highly mobile, rapid fire, surface-to-surface, free flight rocket and guided missile system. It is designed to complement cannon artillery, to attack the enemy deep, and to strike at counterfire, air defense, and high-payoff targets (Department of the Army, 1992). The MLRS is mounted on a self-propelled launcher-loader (SPLL) (an armored vehicle) and is used in general fire support or general fire support reinforcing missions. It can fire as many as 12 free flight rockets or two guided missiles before reloading. Because of its unique signature, this weapon system incorporates "shoot-and-scoot" tactics, which typically requires the crew to perform a fire mission and then rapidly move the vehicle to a hiding position before enemy engagement. The MLRS FCS is operated by a gunner in the cab of the SPLL. The gunner is part of a three-man crew that includes a section chief and a driver.

The Army already uses an institutional version of the FCS which is used in a classroom environment to train soldiers to perform the various operations of the MLRS gunner, including

- Starting and stopping the FCS;
- Loading the computer using the program load unit (PLU) and a portable data source called a "cassette," which is actually a bubble memory device;
- Updating and recalibrating the position determining system (PDS);
- Complying with orders to drive to a loading point;
- Assisting with loading the pods using the self-contained boom and winch;
- Complying with orders to drive to a hiding point;
- Complying with orders to drive to a firing point;

- Firing the weapon at targets under the direction of the battery or battalion FDS;
- Recording and interpreting fault messages and indicators;
- Measuring masking data;
- Directing hang-fire procedures on the launcher.

The gunner receives orders to perform these operations through commands and system messages that appear on the plasma display of the fire control panel (FCP), and he or she responds via the FCP keyboard. In the past, training at Fort Sill has taken place in either (1) a classroom situation using an institutional FCPT in which a maximum of six students, each on his or her own trainer, are monitored by a single instructor through his or her panel, or (2) on an actual M270 vehicle, either in motor pool exercises or in field tactical training. Both forms of training presented limitations.

The institutional trainer uses a large computer tied exclusively to the classroom. Likewise, training in the actual M270 launcher is only available at a relatively small number of vehicle sites. In response to this dilemma, the U.S. Army purchased a prototype lightweight, portable desktop trainer and selected the DIS environment to evaluate its training effectiveness. A depiction of the DIS evaluation environment is presented in Figure 1. Although the stand-alone FCPT may be considered a cost-effective alternative to field training, it alone may not provide soldiers with the needed training feedback.

### Objective

The purpose of this report, therefore, is to describe the TEE of an MLRS FCPT using the DIS environment. As part of this evaluation, the physical and psychological fidelity of the desktop FCPT was assessed.

In a broad sense, this effort served as proof of principle that a) a training device can be successfully integrated into a DIS environment together with actual military command and control devices, and b) performance data can be captured and analyzed from a training device operating in that environment. The TEE focused on the FCPT because it allowed the examination of the feasibility and potential effectiveness of training soldiers of the future in the DIS environment.

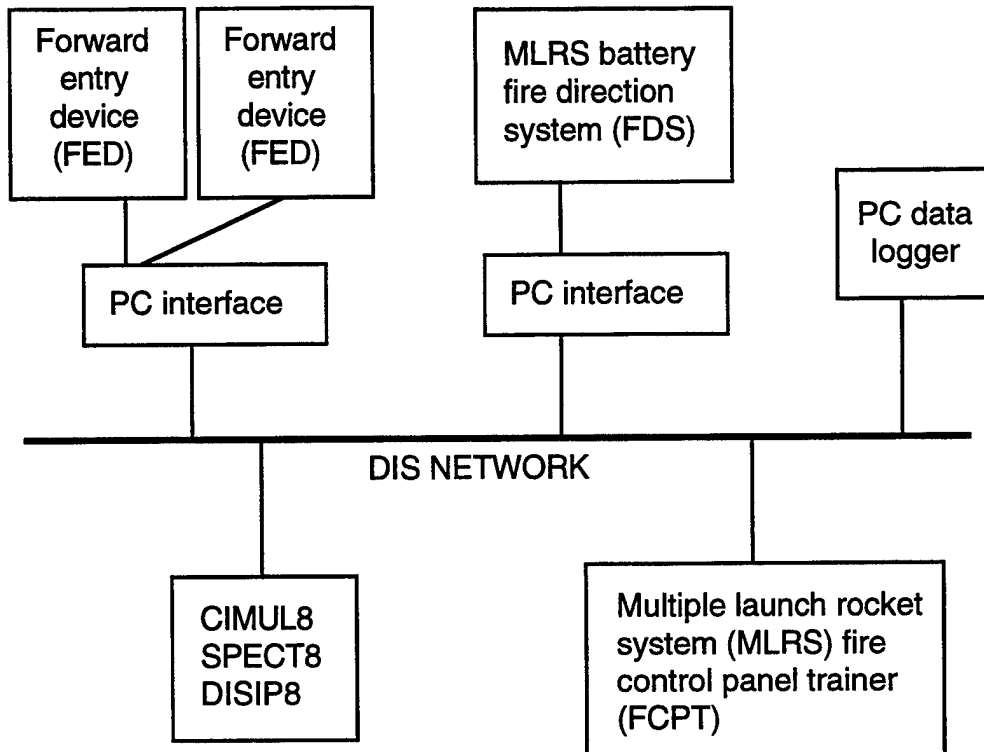

Figure 1. Distributed integrated simulation system.

## METHODOLOGY

### Subjects

Students were requested from the U.S. Army Field Artillery School to serve as subjects for the TEE. A total of 30 students, half of whom were military occupational specialty (MOS) 13P (MLRS fire direction center [FDC] operators) and the other half were MOS 13M (MLRS crew member), supported the TEE as student subjects. There were no significant differences between the two groups in terms of age, education, or extent of MLRS training. These students were in the midst of their advanced individual training (AIT) course work and had some degree of familiarity with the tasks required to operate the FCPT, but none of the students had prior practice on an actual MLRS FCP nor had they any prior practice on an FCPT in a simulation environment. All students were therefore considered naive for the purposes of the TEE (see Table 1). Students were available individually for 2-hour periods during which each trained on the FCPT using the DIS network.

Table 1  
Student Background Data

Variable	Mean	Standard deviation	Minimum	Maximum
Student age (years)	20.23	1.92	18	24
Years of education	12.60	.97	12	15
MLRS training (months)	1.96	.98	0	4

SMEs from the Gunnery Department, most of whom are MLRS instructors, were also requested to support the TEE. A total of 15 SMEs supported the study by reviewing the experimental scenario for tactical accuracy and realism, providing time criterion estimates used to evaluate the students' performance, evaluating the fidelity of the FCPT, and providing input about the utility of the FCPT for training in the simulation environment (see Table 2).

Table 2  
SME Background Data

Variable	Mean	Standard deviation	Minimum	Maximum
SME age (years)	34.07	4.43	26	44
Years of education	13.53	.92	12	15
MLRS training (months)	79.20	36.61	24	120

#### Procedure for Testing Students

Students reported individually for a 2-hour period. First, they were briefed about the simulation system and given an explanation of the purpose of the study. Following this introduction, the students received approximately 1 hour of familiarization with the FCPT using two "canned" lessons administered on the FCPT. See Appendix B for the MLRS mission programs that were used to acquaint students with all aspects of the use of FCPT that would be required during the experimental simulation scenario. Following the familiarization phase, the experimental simulation scenario was initiated. See Appendix B for a description of the

experimental simulation scenario. The following is a summary of activities that occurred during the experimental simulation scenario.

1. CIMUL8™, the simulation generator (see Figure 1), initiated a force-on-force battle simulation. A few minutes into the battle, CIMUL8™ generated tactical fire direction system (TACFIRE) FR GRID messages that were transmitted onto the network and received as call-for-fire (CFF) messages at the battery FDC. The first CFF was then relayed to the FCPT as a fire mission.
2. When the student received the first fire mission at the FCPT, the SPLL was positioned at a hide point. The student was required to perform all the steps necessary to move the SPLL to the fire point requested by the FDC and then fired the mission.
3. After firing the first mission and stowing the weapon, the student performed the steps necessary to move the SPLL to a second hide point as requested by the FDC, at which point, the student received a second fire mission. The student then performed all the steps necessary to move the SPLL to a second fire point as requested and fired a second mission. After the weapon was stowed, the mission was ended and the first run concluded.
4. Each student repeated the experimental simulation scenario three times.

Upon completing the experimental simulation scenario runs, each student was administered a biographical survey. In addition, each student was asked to respond to a questionnaire that was aimed at probing his or her attitude toward simulation training and specifically, how he or she viewed the learning experience on the FCPT using the DIS environment (see Appendix C for the Biographical Data Collection Form and Questionnaire).

#### Data Collection Process

Because of the 2-hour availability of students, data collection efforts focused on obtaining data associated with “initial learning” (e.g., Lane, 1986; Spears, 1983) rather than data related to long-term skill acquisition. Thus, there was no desire nor intention to examine student “learning” in terms of the amount of practice required for students to acquire asymptote skill levels.

#### Time Data

Response time data were automatically captured by the data logger PC as each student proceeded through three experimental simulation scenario runs on the FCPT using the DIS environment. As described earlier, each scenario run required the FCPT operator to successfully perform two separate fire missions. The data logger time-tagged the point in time at

which the subject at the FCPT transmitted the fire mission "will comply" signal back to the Battery FDC, indicating fire mission start time. The data logger also time-tagged the point at which the subject fired the first rocket of the mission, indicating fire mission end time. There were two fire missions per simulation run. Response time data were defined as the amount of time students required to successfully perform all the steps of a fire mission (see Appendix B). The criterion times were subjectively established by the SMEs, based on their experience.

#### Error Data

The error data were obtained through observation. As each student proceeded through the experimental simulation scenarios on the FCPT, a trained research assistant noted any keystroke errors committed by the student and recorded these on a standard data collection form (see Appendix D). It would be advantageous in the future to program the data logger to automatically record the errors. No criterion was necessary for the error rate because committing errors resulted in the use of additional time, and time data were already being captured by the data logger (which were compared against the SME-estimated criteria).

#### Questionnaire Data

Questionnaires were administered to students at the end of each training session. The questionnaire assessed students' attitude about training simulators and their views about the FCPT in the DIS environment (see Appendix C). Eight questions required trainees to rate the system using a Likert-type rating scale ranging from 1 (strongly agree) to 5 (strongly disagree). There were also two open-ended questions requiring written responses from the students. The questionnaire data were then were organized and entered into a data base for subsequent analyses.

SMEs typically reported in groups of two or three to evaluate the FCPT in the simulation environment. They were briefed about the simulation system and the purpose of their participation in the study. Following this introduction, each SME was given the opportunity to proceed through the same simulation scenario on the FCPT that students experienced as well as performing any other actions that they wanted to perform on the FCPT.

After completing their exercises, SMEs were asked to provide estimates of the expected performance time for students performing the experimental simulation scenarios so that students' performance time data could be evaluated relative to a performance standard. SMEs were also administered a biographical data form and questionnaire that was aimed at determining their background and their views about the fidelity and potential effectiveness of training on the FCPT in the simulation environment (see Appendix C). SMEs were asked to rate the FCPT in

the simulation environment using a Likert-type rating scale ranging from 1 (strongly agree) to 5 (strongly disagree). There were also nine open-ended questions requiring written responses from the SMEs. Upon completion, data from the questionnaires were organized and entered into a data base for subsequent analyses.

#### Evaluation of the Physical Characteristics of the FCPT

A human factors evaluation of the physical characteristics of the FCPT was also conducted (see Figure 2). The critical internal components of the FCPT, including the disk drive and internal computer components, the fidelity of the FCPT screen, and the soldier-machine interface were examined by a human factors specialist. Following examination of the system, the human factors specialist provided recommendations for improving the system.

## RESULTS AND DISCUSSION

A variety of analyses was performed on the data collected, including a) analyses of variance (ANOVAs) of the performance time data collected by the data logger, and error data collected through observation, b) descriptive statistics for the time, error, and questionnaire data, and c) content analyses for the open-ended questionnaire items.

#### Time Data

A 2 (MOS: 13M *versus* 13P) x 3 (Scenario Run: Run 1 *versus* Run 2 *versus* Run 3) repeated measures ANOVA of the response time data revealed a significant main effect for Scenario Run,  $F(3, 61) = 11.17, p < .001$ . Post hoc comparisons showed that students required significantly less time to perform fire missions in Run 2 ( $M = 6.27$  minutes) and Run 3 ( $M = 5.57$  minutes) *versus* Run 1 ( $M = 7.59$  minutes). Although there was no statistically significant difference between response times for Run 2 *versus* Run 3, the trend continued in the expected direction (see Table 3 and Figure 3). There was no significant main effect for MOS and there was no significant MOS x Scenario Run interaction.

As displayed in Figure 3, there is a clear learning trend; students required substantially less time to perform fire missions with increased practice over the three scenario runs. It is also noteworthy that a much greater percentage of students were able to meet the performance time criterion in Run 3 (87%) compared to Run 2 (70%) and Run 1 (30%).

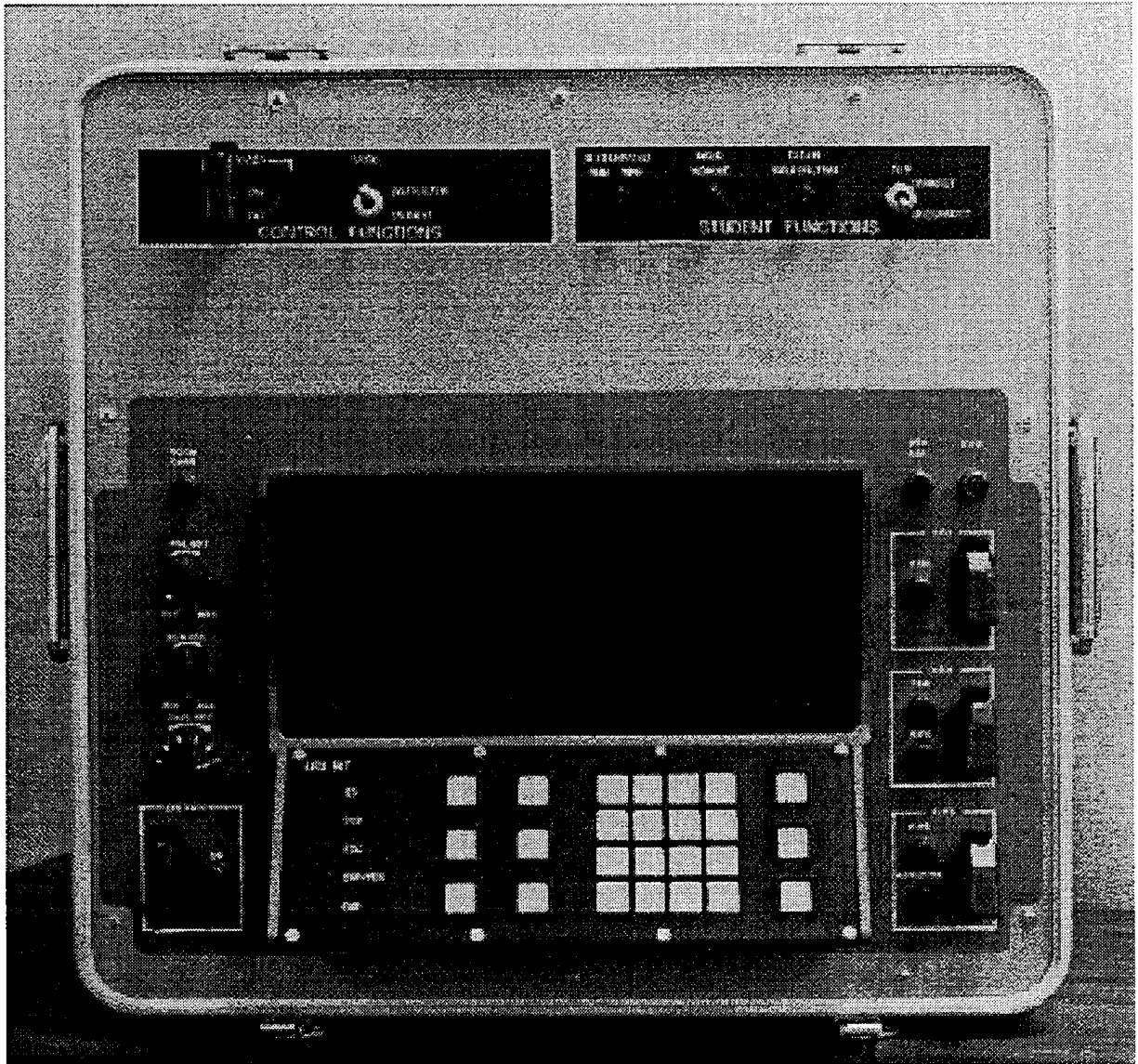

Figure 2. Desktop fire control panel trainer.

Table 3

Response Time Statistics for All Students Across  
Each Experimental Simulation Scenario Run

Run	Fire mission	Mean time	Standard deviation	Minimum time	Maximum time
1	A	3.98	.96	2.50	6.07
	B	3.56	.85	2.56	6.27
	Total	7.59	1.45	5.26	10.46
2	A	3.02	.67	1.95	5.07
	B	3.23	.80	2.28	5.28
	Total	6.27	1.24	4.55	9.09
3	A	2.75	.42	2.10	3.85
	B	2.88	.61	2.13	4.38
	Total	5.57	.84	4.23	7.46

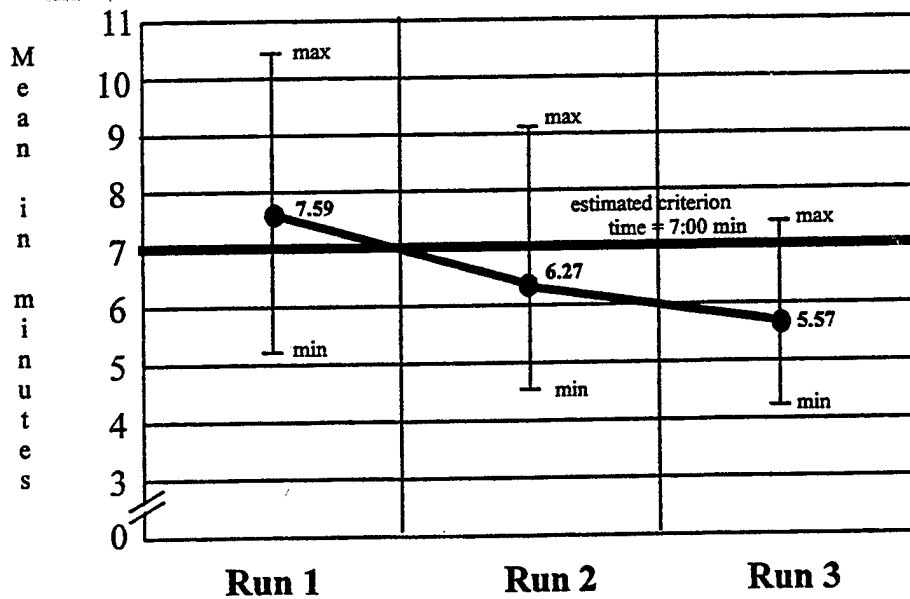

Figure 3. Response times for students for each experimental simulation scenario run (two fire missions each).

Error Data

A 2(MOS: 13M *versus* 13P) x 3 (Scenario Run: Run 1 *versus* Run 2 *versus* Run 3) repeated measures ANOVA of the error data revealed a significant main effect for Scenario Run,  $F(3, 61) = 6.36, p < .01$ . Post hoc comparisons showed that students committed significantly fewer errors in Run 2 (M = 1.04 errors) and Run 3 (M = 0.68 errors) *versus* Run 1 (M = 1.95 errors). Although there was no statistically significant difference between the error rates for Run 2 *versus* Run 3, the trend continued in the expected direction (see Table 4 and Figure 4). There was no significant main effect for MOS and there was no significant MOS x Scenario Run interaction.

Table 4  
Errors Committed by Students for Each Experimental Simulation Scenario Run

Run	Mean	Standard deviation	Minimum	Maximum
1	1.95	1.32	0	5
2	1.04	1.00	0	3
3	.68	.89	0	3

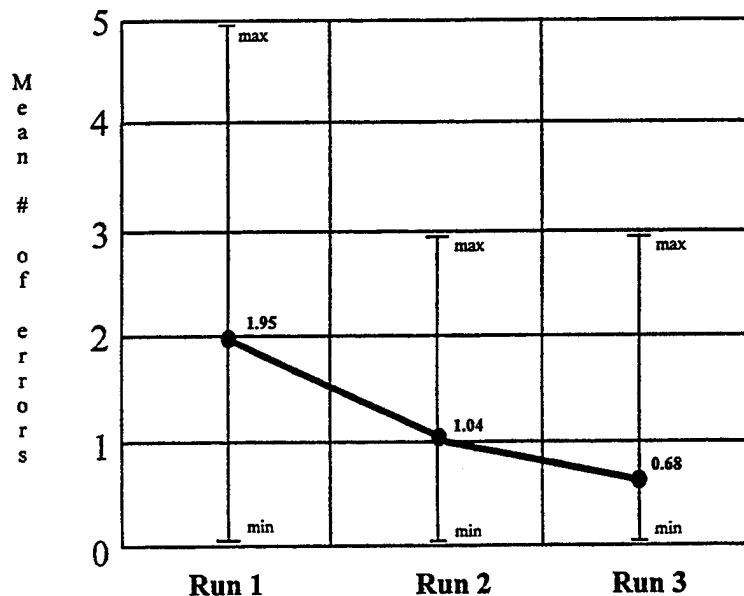

Figure 4. Errors committed by students for each experimental simulation scenario run.

As displayed in Figure 4, by the final scenario run, students performed their missions almost flawlessly. A much greater percentage of students committed *no* errors by Run 3 (64%) as compared with Run 2 (32%) and Run 1 (4.5%). This is particularly meaningful since the error rate decreases concurrently with decreases in response time. Thus, no time-error trade-off was demonstrated by students' performance.

#### Questionnaire Data from Students

As shown in Table 5, students viewed their training on the FCPT in a simulation environment very positively and would recommend this type of training for fellow soldiers. This was not surprising, based on the expressed views of students during their training sessions. On average, they seemed both curious and excited about the prospects of future training in such an environment.

Table 5  
Student Responses to Quantitative Questionnaire Items

Questionnaire statement	Summary statistics <sup>a</sup>	
	Mean	SD
The training on this device was a waste of time	4.37	.96
This training could help prepare me for later training	2.13	1.38
All simulators are worthless	4.73	.69
I wish that I could have had more time training on the device	2.37	1.35
I would <b>not</b> recommend to my sergeant that soldiers be trained on this device	4.73	.64
The FCPT is an important training device	1.87	1.28
Due to the training on this device, I think I will be more confused when I use an MLRS	4.63	.67
The <b>only</b> way to learn something is to use the real thing, not a simulator	4.06	.98

1 = strongly agree  
5 = strongly disagree

Students also responded to two open-ended questionnaire items that allowed them to elaborate their views about the FCPT in the simulation environment. Content analyses were performed on these items. Results of these analyses are presented in Table 6. The vast majority of students indicated that they liked the realism provided by the trainer integrated in the

simulation network. In addition, a significant percentage remarked that their experience on the simulation system helped broaden their understanding of how information is exchanged in a battlefield situation.

Table 6  
Students' Responses to the Two Open-Ended Questionnaire Items

Questionnaire statement	Response to statement (percent of respondents with similar response)
I liked this training device because	<p>It is more interactive and like really being there (41.1%)</p> <p>It helped me better understand information flow on a battlefield (29.4%)</p> <p>It helps sharpen skills learned in the classroom (29.5%)</p>
I did not like this training device because	<p>Keyboard glitches (the "3" key sticks) (22.2%)</p> <p>It should graphically display "moves" on panel (11.1%)</p> <p>It does not tell you what to do (11.1%)</p>

The relatively few negative comments that were given by students were directed at the physical characteristics of the FCPT such as the keypad and the lack of a graphic simulation of vehicle "moves." The periodic keypad problem has been noted by previous users and should be simple to correct. Interestingly, based on anecdotal information from SMEs, it is not at all unusual for soldiers to experience "sticking" keys on the actual MLRS FCP because certain keys are used too much. With respect to the addition of a graphic display simulating vehicle movement on the CIMUL8™ simulation presentation, consideration should be given to this and any other means of continuing to upgrade the realism of the simulation system as a whole.

#### Questionnaire Data from SMEs

As shown in Table 7, SMEs also viewed the FCPT in the simulation network very favorably. Their responses indicate a positive attitude about the utility of the FCPT as a training device that, in the present environment, could effectively supplement and maintain soldier training.

Table 7  
SME Responses to Quantitative Questionnaire Items

Questionnaire statement	Summary statistics <sup>a</sup>	
	Mean	SD
The training on this device was a waste of time	4.50	.94
This training is a nice addition to classroom training	1.80	1.08
All simulators are worthless	4.40	.83
More time should be spent training on this device	2.20	.94
I do <b>not</b> recommend that soldiers be trained on this device	4.47	.92
The FCPT is appropriate for new trainees	2.27	1.28
The FCPT should be used only after classroom training	3.00	1.31
The <b>only</b> way to learn something is to use the real thing, not a simulator	4.47	.74
The FCPT is only appropriate for soldiers to maintain their skill level	3.73	1.10
The FCPT looks and operates like the real MLRS FCP	2.33	1.18
This device may give soldiers a false sense of confidence about using the MLRS FCP	4.13	.92

1 = strongly agree  
5 = strongly disagree

The SMEs responses to the open-ended questionnaire items are summarized in Table 8. Like the students, SMEs recognized the added realism that the FCPT provided when integrated into the DIS environment. In general, they thought that although the training in this environment may not be “easier” for new trainees, it provided a much more realistic representation of the tasks that must be mastered. They felt that because tasks such as communications with the FDC and fire missions were more lifelike, soldiers would develop a greater level of confidence in their abilities to perform these tasks in the field. Thus, there would be less of a transition period for soldiers going from the classroom to the field and for soldiers who need to rapidly refine previously acquired skills (e.g., soldiers who have not been directly assigned to the SPLL in recent months).

SMEs also focused on the time and cost benefits that such training could afford versus only field and classroom training.

Table 8

## SMEs' Responses to the Nine Open-Ended Questionnaire Items

Questionnaire statement	Response to statement <sup>a</sup> (percent of respondents with similar response)
I liked this training device because	It is more realistic (61%) It is integrated with the other command and control devices (28%)
I did not like this training device because	Software and keypad glitches (13%)
Does the desktop FCPT make learning any FCP tasks <b>easier</b> compared to the institutional trainer?	Yes - communication with FDC, fire missions, control over tasks, better for building confidence (55%) No - not really "easier" (45%)
Does the desktop FCPT make learning any FCP tasks <b>harder</b> compared to the institutional trainer?	No (100%)
Does the desktop FCPT make learning any FCP tasks <b>easier/harder</b> compared to the FCP in the SPLL?	Much less time and expense required <i>versus</i> training on FCP in SPLL (40%) Easier to learn certain functions on FCPT <i>versus</i> FCP in SPLL (30%) Could effectively supplement/maintain field training (20%)
What advantages does using the trainer in the interactive simulation environment provide versus classroom training?	FCPT in simulation environment is more realistic training (50%) More cost-effective, mobile; can be used in "Sgt's Time Trng" (16.6%)
How could operating in the DIS change the training of personnel at higher levels of command?	Could give higher level personnel a better understanding of information flow, time constraints, and capabilities of the MLRS SPLL (75%) Could give them a more realistic representation of the battlefield environment (16.6%)
What particular "type" of Gunner Trainee would benefit from training on the desktop FCPT in the DIS?	Crewmen not yet assigned directly to the SPLL; refresher training (70%) National Guard soldiers (20%) New Gunner trainees (10%)
What particular "type" of Gunner Trainee would be <b>negatively</b> affected by training on the desktop FCPT in the DIS?	None (100%)

\*Only responses that occurred with a frequency of  $\geq 2$  have been included in this table. Thus, the percentages associated with each question may not total 100%.

In their view, training on the FCPT in this simulation network could supplement field and classroom training and could be used without extensive planning (e.g., training on an “as needed basis”). They also saw the system providing a potentially significant training benefit to National Guard units who, because of future time and training cost constraints, may not otherwise have sufficient hands-on training opportunities. SMEs also suggested that it could be used to give upper level personnel a better understanding of the capabilities and constraints of the MLRS SPLL which could assist them in battle planning activities.

#### Human Factors Evaluation of the Physical Characteristics of the FCPT

As part of the TEE, a human factors evaluation was conducted on the physical characteristics of the FCPT. This section outlines the results of the human factors evaluation, together with the recommended actions to address these issues.

First, an examination of the critical components of the FCPT, including the disk drive and internal computer components, revealed that these components are not readily accessible. In fact, the rear of the device must be completely separated from the face before any software upgrades or minor repairs can be made in the trainer. Although this significantly decreases the chances of tampering with the hardware and software of the device, it also significantly increases the likelihood of damage during repairs. Since upgrades and minor repairs are common for these types of devices, this poses a considerable risk to the longevity of the trainer. It is therefore recommended that the trainer be modified to include removable access panels at the rear of the casing which would allow access to the disk drive and internal computer system. This would allow convenient software and hardware modifications and greatly decrease the chance of damaging this valuable device.

Second, although neither the students nor the SMEs complained of the lack of fidelity of FCPT screen, many did remark about the noticeable difference between it and an actual MLRS FCP display. Like the MLRS FCP display, the FCPT presents orange characters on a dark background. However, because the FCPT uses a conventional color monitor as opposed to the plasma screen used in the MLRS FCP, there is a noticeable disparity in the tint of the screens. This is not perceived as critical with respect to training effectiveness since relevant literature (e.g., Sawyer, Pain, Van Cott, & Banks, 1982; Westra et al., 1986) indicates that increasing physical fidelity to the point of perfection may not significantly improve training effectiveness. However, the difference was noted by many users, and this information should be weighed appropriately during future upgrades of the FCPT.

Third, as stated earlier, there was a problem with the FCPT keyboard (i.e., sticking of the "3" key) because of overuse. If not corrected, problems of this type can contribute to increases in response time and error rate (Galitz, 1989). This problem could therefore distort performance data that are collected during training and could pose an artificial distraction to users.

Finally, as mentioned earlier, users of the system noted a lack of realism in the simulation of vehicle moves. The FCPT currently simulates vehicle moves by trainees pressing a "MOVE" button on the panel. This method, although better than an "automatic move," in which vehicle moves are not simulated at all, does not provide users with a visual image of the move action as it occurs. It is therefore recommended that the FCPT be upgraded to include a graphic display of vehicle move actions that would create a higher degree of realism.

## CONCLUSION

Based on the information gathered during the TEE, the feasibility and effectiveness of training in the DIS environment appears promising. As reported in the previous section, data collected about student performance clearly demonstrate that significant early learning occurs for students training on the MLRS FCPT in the simulation environment. Both the time required for students to perform fire missions and the number of errors committed during the performance of fire missions decreased substantially with practice, and in the case of time, the estimated criterion time became significantly better.

The general outlook that students and SMEs had toward the training system was also encouraging. Students viewed training on the FCPT in this DIS environment very positively and felt confident that it could help them and others do their job more effectively. SMEs believe that the integrated FCPT provides superior realism and could serve as an effective training tool for supplementing early learning as well as refresher training.

Aside from the abundance of positive information that was gathered over the course of the TEE, some potential research initiatives clearly remain. Most notable during the TEE was the lack of an automated data collection capability. The data collection process was substantially limited by the current data collection capabilities of the DIS. The data that were captured represent a small fraction of the data available for capture. The potential certainly exists (e.g., Kaye & Copenhaver, 1992) for automated collection, reduction, and analysis of many forms of data that are currently not used by the DIS system. An improved data collection system should be developed that allows the automatic capture and analysis of a variety of performance data

including total time, mission segment time, keystrokes, errors (including when they occur), and accuracy. The proposed system should also have the flexibility to allow the insertion of system-specific performance measures (i.e., specific to the device on the DIS) that could supply feedback to the student and allow instructors to track student performance. This data collection system would provide a means to obtain and analyze performance data from the operation of any military device that is integrated into the DIS network.

Further exploration is also required in the area of integrating other real-world command and control devices into the DIS network. By design, the interface used to support the current command and control devices in the DIS network can be implemented to support other command and control devices and could serve as a means to test the interaction of new and developing command, control, and communications (C3) technologies. The interface could also be used to allow new and developing systems (e.g., the advanced field artillery tactical data system (AFATDS), the improved data modem (IDM), and the aviation mission planning system (AMPS) to test their capabilities with existing systems in the DIS environment.

In conclusion, a significant step has been taken toward bringing real-world command and control systems into the synthetic environment for training, testing, evaluation, and data collection purposes. This TEE has provided a unique opportunity to investigate another advantage of DIS applications. The present findings provide the basis for further exploring the DIS as a training and research instrument.

## REFERENCES

- Bouwens, C.L., Ching, H.L.F., & Pierce, L.G. (in press). Development and engineering of a distributed interactive simulation system (Contractor Report ARL-CR- ). Aberdeen Proving Ground, MD: U.S. Army Research Laboratory.
- Department of the Army (1992). Tactics, techniques, and procedures for the multiple launch rocket system (MLRS) operations (Field Manual Number 6-60). Washington, DC: Author.
- Galitz, W.O. (1989). Handbook of screen format design (3rd ed.). Wellesley, MA: QED Information Sciences, Inc.
- Kaye, R.D., & Copenhaver, M.M. (1992). Assessment of the institutional fire control system trainer: A review of a number of issues involved in training on an automatic fire control system. Falls Church, VA: CAE-Link Corporation.
- Lane, N.E. (1986). Skill acquisition curves and military training (IDA Order No. 5540). Orlando, FL: Essex Corporation.
- Sawyer, C.R., Pain, R.F., Van Cott, H., & Banks, W.N. (1982). Nuclear control room modifications and the role of transfer of training principles: A review of the issues and research (NUREG/CR-2828). Washington DC: U.S. Nuclear Regulatory Commission.
- Spears, W.D. (1983). Processes of skill performance: A foundation for the design and use of training equipment (NAVTRAEQUIPCEN Technical Report 78-C-0113-4). Orlando, FL: Naval Equipment Training Center (DTIC No. AD-A13679).
- Westra, D.P., Lintern, G., Sheppard, D.J., Thomley, K.E., Mauk, R., Wrightman, D.C., & Chambers, W.S. (1986). Simulator design and instructional features for carrier landing: A field transfer study (NAVTRASYSSEN 85-C-0044-2). Washington, DC: U.S. Naval Air Systems Command.

APPENDIX A  
ACRONYM LIST

## ACRONYM LIST

AFATDS	advanced field artillery tactical data system
AIT	advanced individual training
AMPS	aviation mission planning system
ARL	Army Research Laboratory
CAE	Canadian Aviation and Electronics
C3	command, control, communications
CFF	call for fire
CIMUL8™	A highly flexible, non-interactive simulation driver developed by BDM International, Inc. (includes CIMUL8™, SPECT8™, DISIP8™)
D&SA	Depth and Simultaneous Attack
DIS	distributed interactive simulation
DMD	digital message device
DSI	defense simulation internet
FCP	fire control panel
FCPT	fire control panel trainer
FCS	fire control system
FDC	fire direction center
FDDM	fire direction data manager
FDS	fire direction system
FED	forward entry device
FR GRID	Type of message used to initiate a fire request by reporting a target location using grid coordinates.
FWR	fire when ready
IDM	improved data modem
LCU	lightweight computer unit (AN/GYK-37V)
MLRS	multiple launch rocket system
MOS	military occupational specialty
PC	personal computer
PDS	position determining system
PDU	protocol data unit
PLU	program load unit
SME	subject matter expert
SPLL	self-propelled launcher-loader
TACFIRE	tactical fire direction system
TEE	training effectiveness evaluation

APPENDIX B  
MLRS MISSION PROGRAMS

**Fire When Ready (FWR) Mission (Program 124).** In this exercise, the student receives a Call For Fire (CFF) message from Battery and performs a FWR mission. The vehicle is not parked at the firing site. The rockets are armed and fired. The mission ends when LLM STOW is pressed.

Initial conditions:                   MODE Switch in INSTRUCTOR  
                                           SYS PWR Switch on FCP - ON  
                                           PLU Switch DISCONNECTED  
                                           ARM Switch on FCP - SAFE

**Fire When Ready (FWR) Mission (Program 124)**

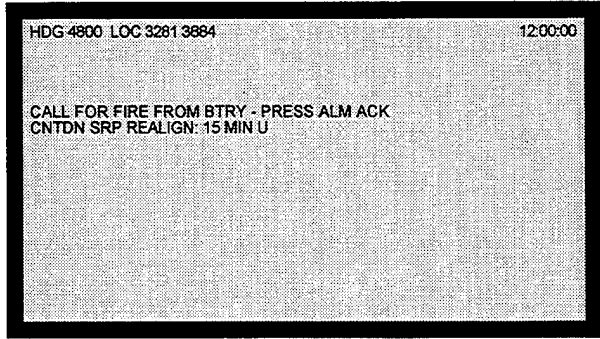
SEQUENCE NO.	STEP NO. IN PROGRESS	ACTIONREMARKS
1		Student verifies the prompt ENTER LESSON NUMBER. 000 is displayed.
2		Student enters 124 on FCP keypad and verifies ENTER LESSON NUMBER. 124 is displayed.
3		Student places MODE switch to STUDENT and observes prompt on display will blink and then be redisplayed. Student verifies SYS PWR light ON; SRP RDY light ON.
4		FCP displays:
		
5		Student presses ALM ACK key on FCP keypad and verify the following prompts
6		WILL COMPLY MESSAGE READY - PRESS XMIT appears on FCP.

**Fire When Ready (FWR) Mission (Program 124) - Continued**

SEQUENCE NO.	STEP NO. IN PROGRESS	ACTION/REMARKS
--------------	----------------------	----------------

7 FCP displays:

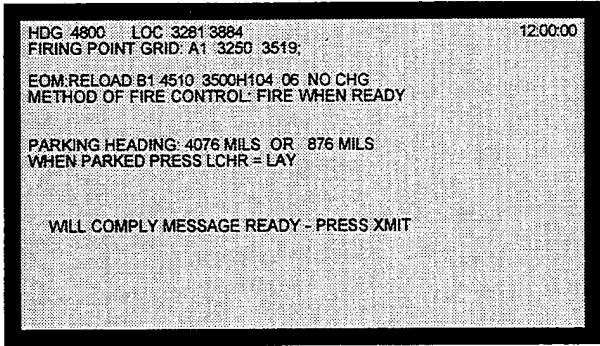

8 Student presses XMIT.

9 There is a 30-second delay to simulate vehicle movement to firing point. Vehicle heading changes.

10 Student presses LCHR LAY key.

11 FCP displays:

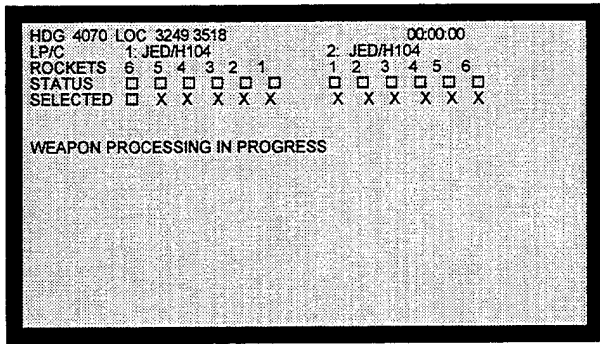

12 There is a 30-second delay to simulate vehicle movement to firing point.

**Fire When Ready (FWR) Mission (Program 124) - Continued**

SEQUENCE NO.	STEP NO. IN PROGRESS	ACTION/REMARKS
--------------	----------------------	----------------

13 FCP displays:

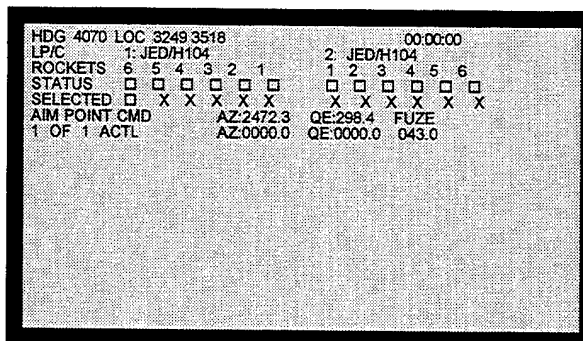

- 14 After LLM reaches AIM POINT, student verifies ARM ROCKETS prompt is displayed.
- 15 Student places ARM switch on FCP to ARM position and verifies SAFE light is OFF and ARM light is ON. ARM ROCKETS prompt is replaced by FIRE ROCKETS.
- 16 Student actuates FIRE switch by placing ARM switch to the ARM position and holding it there until the FIRE light goes on.
- 17 Student verifies 6 rockets are fired at approximately 6-second intervals.
- 18 SAFE ROCKETS END OF MISSION prompt will be displayed when all rockets have been fired.
- 19 Student places ARM switch to SAFE.
- 20 MISSION FIRED MESSAGE TRANSMITTED will be displayed for 5 seconds.

*Fire When Ready (FWR) Mission (Program 124) - Continued*

SEQUENCE NO.	STEP NO. IN PROGRESS	ACTION/REMARKS
--------------	----------------------	----------------

21

FCP displays:

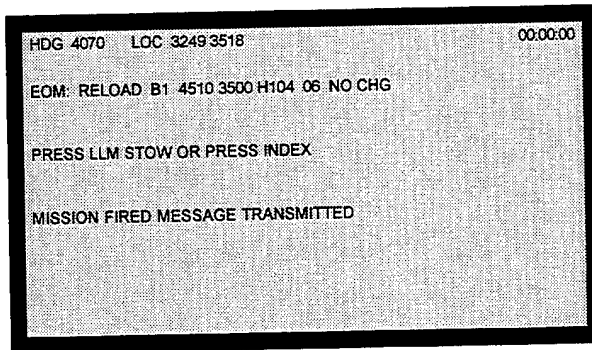

22

Student presses LLM STOW. LLM begins to stow.

AZIMUTH RESOLVER:

ELEVATION RESOLVER:

23

Lesson ends, FCP screen goes blank.

**Basic Fire Mission (Program 210).** This mission starts with an unloaded vehicle parked in the maintenance area with the bubble memory purged. Student will be required to load bubble memory using program load unit (PLU). The instructor provides the student with SPLL STARTUP DATA and SPLL MISSION DATA forms for manual entry of data into the FCS. The student will be required to perform SYSTEM STARTUP, PDS STARTUP, and COMMUNICATIONS STARTUP using the data provided in the SPLL STARTUP DATA form. The student will then be required to manually enter the mission data provided on the SPLL MISSION DATA form. The student is then required to perform a PDS update. The mission will then simulate a vehicle movement to a reload point where 12 M77 rockets will be loaded. After reload operation, a PDS calibration will be performed. After PDS calibration has been accomplished, the mission will then simulate a vehicle movement to a hide point. Student will be required to place the FCS in a COOL mode.

**Basic Fire Mission (Program 210)**

SEQUENCE NO.	STEP NO. IN PROGRESS	ACTION/REMARKS
		SYS PWR switch on FCP in OFF
1		Student presses 210 on ICP keyboard. Notes 210 in PROGRAM LOADED display on ICP.
2	0000	Student presses START. Note the RUNNING light on ICP comes on.
3		Student connects PLU to PIM/PLU connector on student control station.
4	0000	Student sets SYS PWR switch on FCP to ON.
5		Student observes the FCS reprogramming starts immediately.

**NOTE**

The prompt CNTDN SRP REALIGN: 000 MIN is displayed if there are no conflicting prompts displayed on line 10 of the FCP display. If a U is displayed, the data is uncompensated. If the countdown timer runs out of time, SRP ALIGN WARNING prompt will be displayed on line 7 of the currently displayed prompts.

6 FCP will display the following prompts in the order indicated.

EEPROM REPROGRAMMING IN PROGRESS

EEPROM REPROGRAMMING COMPLETE

**Basic Fire Mission (Program 210) - Continued**

SEQUENCE NO.	STEP NO. IN PROGRESS	ACTION/REMARKS
--------------	----------------------	----------------

6.1 FCP displays:

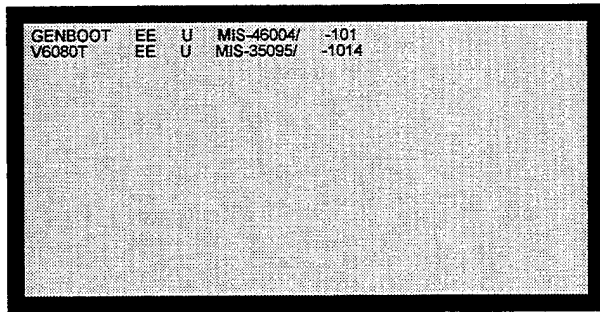

PLU DIRECTORY READ IN PROGRESS  
PLU FILE READ IN PROGRESS  
BUBBLE FILE WRITE IN PROGRESS  
BUBBLE MEMORY DOWNLOAD IN PROGRESS

**NOTE**

The PLU FILE READ IN PROGRESS and BUBBLE FILE WRITE IN PROGRESS prompts will repeat four times.

7 After a successful reprogramming of the EEPROM and/or program bubble memories, the FCP WILL DISPLAY:



7.1 Student places SYS PWR switch on FCP to OFF.

**Basic Fire Mission (Program 210) - Continued**

SEQUENCE NO.	STEP NO. IN PROGRESS	ACTION/REMARKS
8		Student disconnects PLU cable from PIM/PLU connector on student control station.
8.1	0200	Place SYS PWR switch on FCP in ON.
8.2	0300	FCP displays:

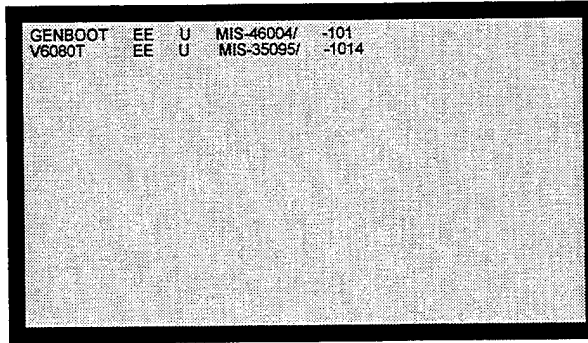

8.3		BUBBLE MEMORY DOWNLOAD IN PROCESS
8.4	0300	FCP displays:

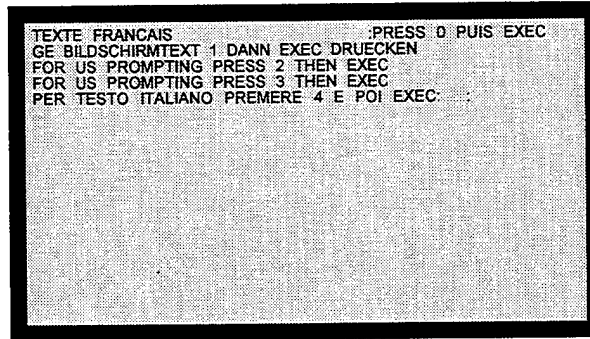

9		Instructor provides students with SPLL STARTUP DATA form.
10		Student selects US prompting.
11	0323	Student enters Time of Day.

**Basic Fire Mission (Program 210) - Continued**

<b>SEQUENCE NO.</b>	<b>STEP NO. IN PROGRESS</b>	<b>ACTION/REMARKS</b>
---------------------	-----------------------------	-----------------------

11.1	0300	FCP displays:
------	------	---------------

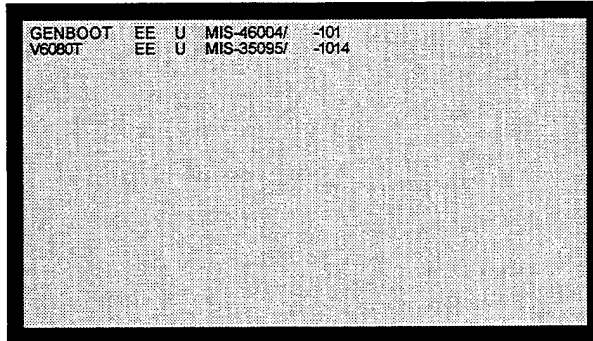

11.2	0200	BUBBLE MEMORY DOWNLOAD IN PROGRESS
------	------	------------------------------------

11.3	0300	FCP displays:
------	------	---------------

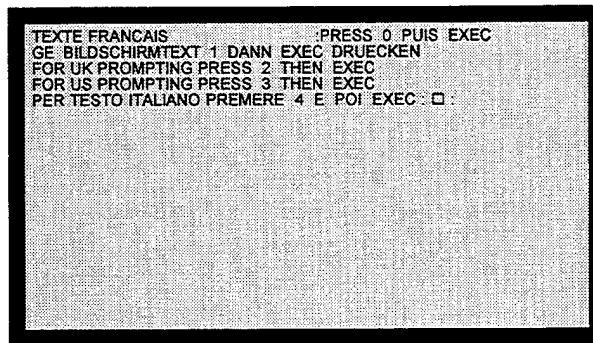

12	0218	Student selects PURGE DATABASE OPTION 1 = YES and presses STORE. WEAPON PROCESSING IN PROGRESS appears.
----	------	---------------------------------------------------------------------------------------------------------

**NOTE**

Enter the SYSTEM, PDS and COMMS STARTUP data as quickly as possible. The SRP/PDS software version ID must be verified after the data is entered, but before the SRP alignment has elapsed.

**Basic Fire Mission (Program 210) - Continued**

SEQUENCE NO.	STEP NO. IN PROGRESS	ACTION/REMARKS
--------------	----------------------	----------------

13		FCP displays:
----	--	---------------

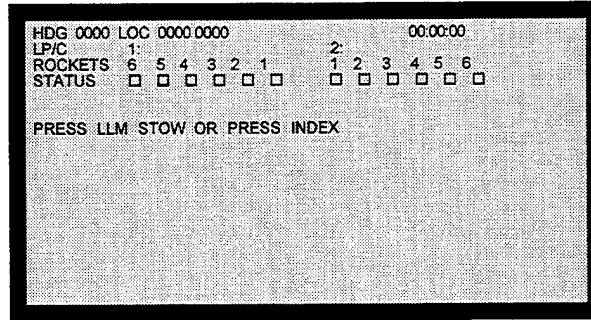

14	0418	Student presses INDEX.
15		FCP displays INDEX MENU.
16	0421	Student selects MENUS from INDEX MENU.
17	0423	Student selects STARTUP MENU from MENUS.
18		Student selects option 0 = SYSTEM from STARTUP MENU.

**NOTE**

The student enters the following data given on the SPLL STARTUP DATA form, except as indicated below, and presses STORE after each entry.

19	0518	EASTING
20		NORTHING
21		ALTITUDE
22		GRID ZONE
23		HIGH QE
24		USE LP/C2 ON MALFUNCTION
25		HANGFIRE
26		FCP displays SRP ALIGNING and TIME TO GO: 8:00 if SYSTEM STARTUP is completed prior to SRP READY signal being received.

**Basic Fire Mission (Program 210) - Continued**

SEQUENCE NO.	STEP NO. IN PROGRESS	ACTION/REMARKS
27		Student presses INDEX.
28	0521	Student selects MENUS from INDEX MENU.
29	0523	Student selects STARTUP MENU from MENUS.
30		Student selects option 1 = PDS from STARTUP MENU.
31	0618	Student enters odometer scale factor (OSF) and presses STORE.
32		Student enters azimuth crab angle (ACA)(65496) and presses STORE.
33		Student enters elevation crab angle (ECA)(00030) and presses STORE.
34		FCP displays SRP ALIGNING and TIME TO GO: 8:00 if PDS is completed prior to SRP READY signal being received.

**NOTE**

The instructor can shorten this time to 45 seconds, if desired, by pressing the 3 blank key on the ICP keyboard.

35		After countdown, STARTUP COMPLETE, SRP READY is displayed on the FCP.
36		Deleted.
37	0618	Student presses INDEX.
38	0621	Student selects COMMS STARTUP from INDEX MENU.

**NOTE**

Student should complete COMMS STARTUP before SRP completes alignment.

39	0623	Student enters the following COMMS STARTUP DATA and presses STORE after each entry.  ON THE AIR = 0 CRYPTO STATUS = 0 PL/TP BIT = 0 V24 BIT RATE = 3  OWN ADDRESS = 12 OWN BIT = 04 BTRY ADDRESS = 56 PLT/TP ADDRESS = 03
----	------	---------------------------------------------------------------------------------------------------------------------------------------------------------------------------------------------------------------------------------------------------------

**Basic Fire Mission (Program 210) - Continued**

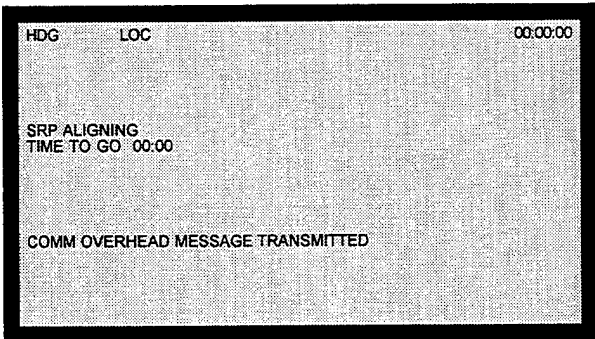
SEQUENCE NO.	STEP NO. IN PROGRESS	ACTION/REMARKS
		BIT RATE = 1 ACCESS DELAY TIME = 3 FSK PAIR = 0 BLOCK MODE = 0  CMP TO USE FIELD 18 AND 19 = 2 TO BTRY SERIAL NUMBER 1 = 0 TO BTRY SERIAL NUMBER 2 = 0 CMP TO USE FIELD 21 AND 22 = 0  TO PLT/TP SERIAL NUMBER 1 = 0 TO PLT/TP SERIAL NUMBER 2 = 0 CMP TO ACCEPT NEXT SERIAL NO. = 0 PREAMBLE = 3  RADIO NET BUSY OVERRIDE = 0 FIELD 26: Press NEXT FIELD FIELD 27: Press NEXT FIELD FIELD 28: Press NEXT FIELD  FIELD 29: Press NEXT FIELD FIELD 30: Press NEXT FIELD FIELD 31: Press NEXT FIELD FIELD 32: Press NEXT FIELD
40	0624	Student presses EXEC when all COMMS STARTUP DATA has been entered.
41		FCP displays SRP ALIGNING and TIME TO GO: 8:00 if COMMS STARTUP is completed prior to SRP READY signal being received.
42		FCP displays:
		 <p>The screenshot shows a terminal window with a dark background and light text. At the top left, it says 'HDG' and 'LOC'. At the top right, it shows a timer '00:00:00'. In the center, it displays 'SRP ALIGNING' followed by 'TIME TO GO 00:00'. At the bottom, it says 'COMM OVERHEAD MESSAGE TRANSMITTED'.</p>
43		FCP displays STARTUP COMPLETE - SRP READY when the ready indication is received from the SRP.

**Basic Fire Mission (Program 210) - Continued**

SEQUENCE NO.	STEP NO. IN PROGRESS	ACTION/REMARKS
44		FCP displays COMM OVERHEAD MESSAGE TRANSMITTED for 5 seconds when startup sequence is complete.
44.1	0623	Student presses INDEX.
44.2	0621	Student selects MENUS from INDEX MENU.
44.3	0623	Student selects MISCELLANEOUS MENU from MENUS.
44.4	0623	Student selects SOFTWARE VERSION ID, option 0, from MISCELLANEOUS MENU.
44.5	0623	FCP displays:

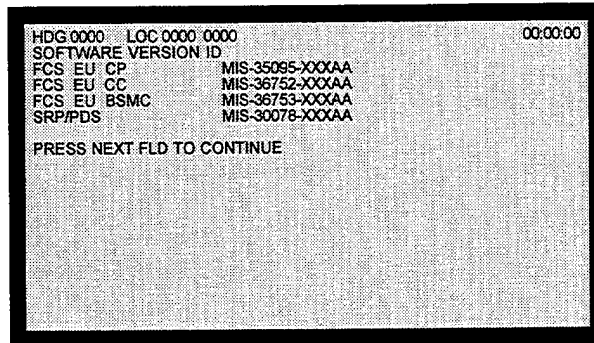

44.6	0623	Student verifies that MIS-30078-107 appears for the SRP/PDS version ID.
44.7	0623	The instructor may press the blank key on ICP to shorten SRP alignment to 45 seconds. When the SRP alignment is completed, the SRP RDY indicator comes on.
44.8	0623	FCP displays:

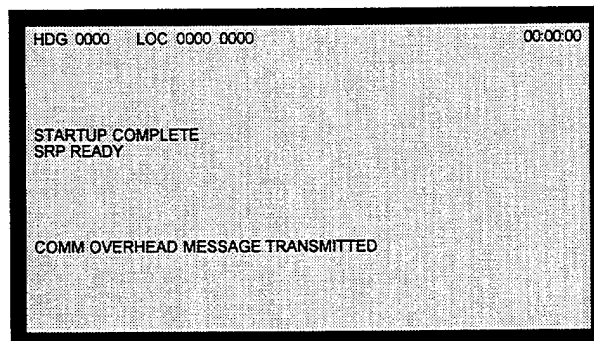

**Basic Fire Mission (Program 210) - Continued**

SEQUENCE NO.	STEP NO. IN PROGRESS	ACTION/REMARKS
44.9	0723	Student presses INDEX.
44.10	0721	Student selects MENUS from INDEX MENU.
44.11	0723	Student selects MISCELLANEOUS MENU from MENUS.
44.12	0723	Student selects SOFTWARE VERSION ID, option 0, from MISCELLANEOUS MENU.
44.13		FCP displays:

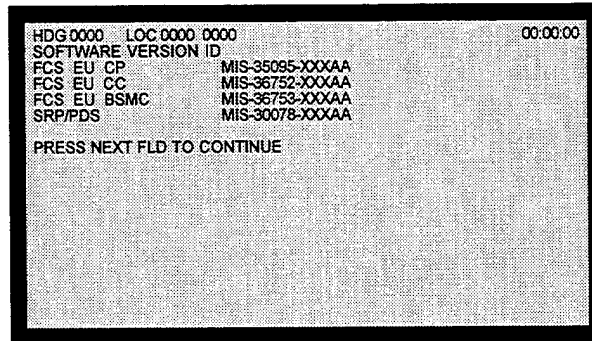

44.14		Student verifies that MIS-30108-107 appears for the SRP/PDS version ID.
45		Student presses INDEX.
46		Student selects MENUS from INDEX MENU.
47		Student selects MESSAGE MENU from MENUS.
48		Student selects REQUEST from MESSAGE MENU.
49		FCP displays:

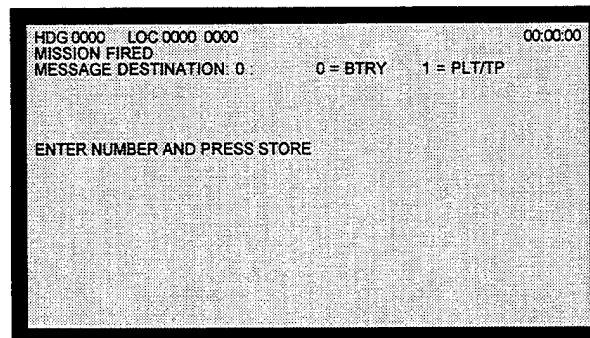

**Basic Fire Mission (Program 210) - Continued**

SEQUENCE NO.	STEP NO. IN PROGRESS	ACTION/REMARKS
50		Student selects MESSAGE DESTINATION = 0.
51		Student selects DATABASE UPDATE from REQUEST MENU.
52		Student selects option 7: ALL LOCATIONS from DATABASE UPDATE menu and presses STORE.
53		FCP displays:

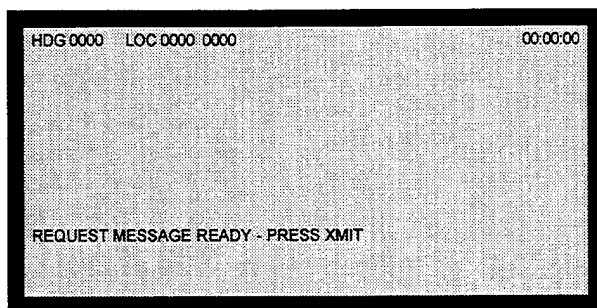

54		Student presses XMIT.
55		Student presses INDEX.
56	1321	Student selects MENUS from INDEX MENU.
57	1323	Student selects MISCELLANEOUS MENU from MENUS.
58		Student selects POLAR COORD from MISCELLANEOUS MENU.
59		Student selects SURVEY CONTROL POINT, option 4, from POLAR COORDINATES MENU.
60		FCP displays:

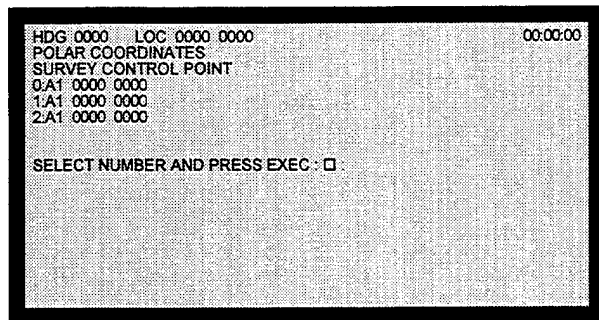

**Basic Fire Mission (Program 210) - Continued**

SEQUENCE NO.	STEP NO. IN PROGRESS	ACTION/REMARKS
--------------	----------------------	----------------

61	1518	Student selects number 2 and presses EXEC.
----	------	--------------------------------------------

62		FCP displays:
----	--	---------------

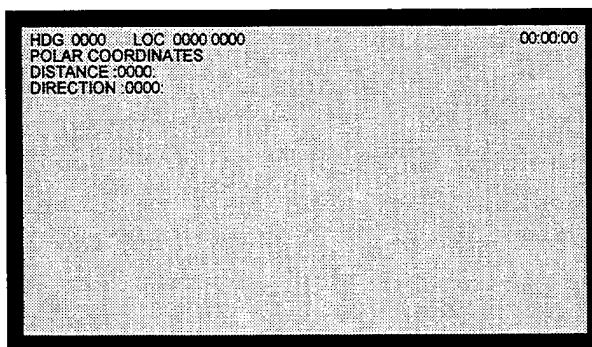

63		There is a 30-second delay to simulate vehicle movement to survey control point.
----	--	----------------------------------------------------------------------------------

64	1723	Student presses INDEX.
----	------	------------------------

65	1721	Student selects MENUS from INDEX MENU.
----	------	----------------------------------------

66	1723	Student selects SRP/PDS MENU from MENUS.
----	------	------------------------------------------

67		Student selects UPDATE PDS, option 1, from SRP/PDS MENU.
----	--	----------------------------------------------------------

68		FCP displays:
----	--	---------------

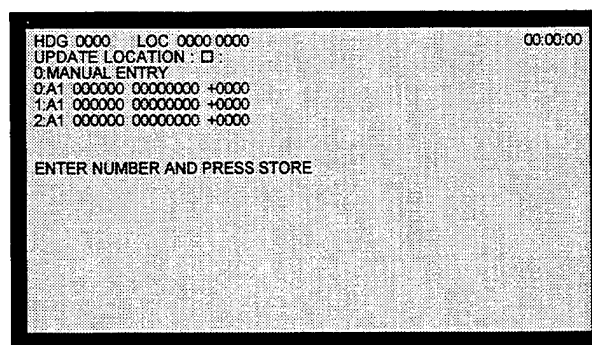

**NOTE**

Option 1, 2, and 3 are survey control points received in a DBU or COM message and stored in the data base. Selecting option 0 allows the student to manually enter the coordinates for the update location.

**Basic Fire Mission (Program 210) - Continued**

SEQUENCE NO.	STEP NO. IN PROGRESS	ACTION/REMARKS
--------------	----------------------	----------------

69		Student enters number 3 and presses STORE.
----	--	--------------------------------------------

70		FCP displays:
----	--	---------------

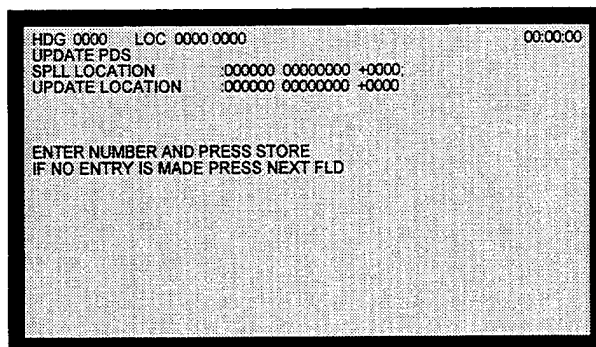

71	1918	Student presses NEXT FLD. FCP displays:
----	------	-----------------------------------------

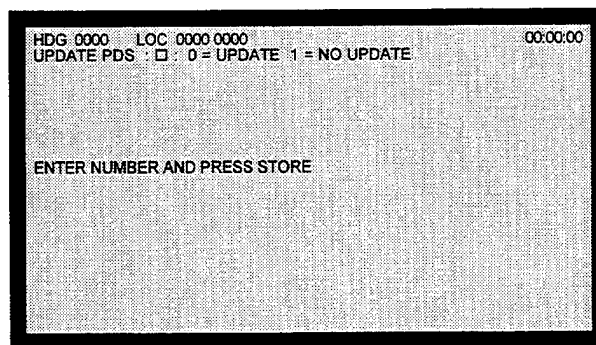

72	1924	Student enters 0 and presses STORE to clear FCP
----	------	-------------------------------------------------

**NOTE**

FCS EU sends a message to SRP/PDS to indicate that an update was selected. The PDS launcher location will be updated.

After the update location has been entered and student has pressed STORE, a comparison of the launcher location and the update location is performed.

If the comparison of the launcher location and update location results in deltas of 550 meters or greater for easting or northing, or 110 meters for altitude, LARGE PDS POSITION ERROR will be displayed.

If LARGE PDS POSITION ERROR is displayed, the student may then press LAST FLD to review the update location data and change it if desired.

73	2018	Student presses INDEX.
----	------	------------------------

**Basic Fire Mission (Program 210) - Continued**

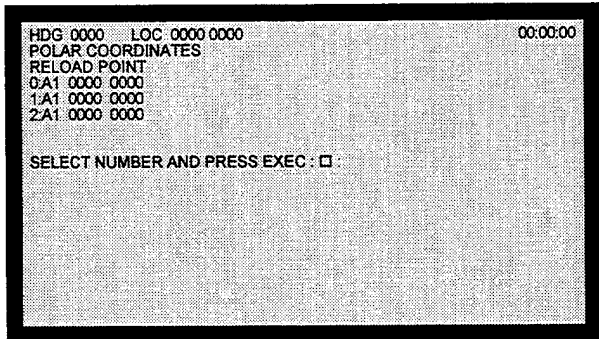
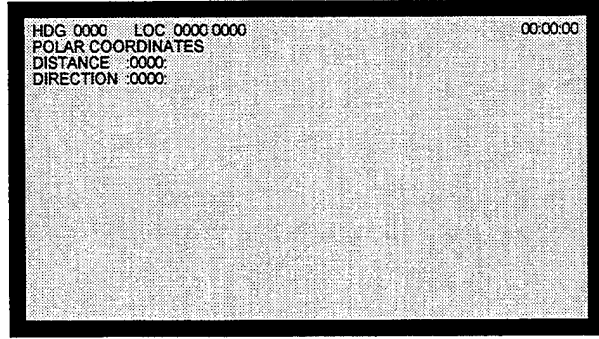
SEQUENCE NO.	STEP NO. IN PROGRESS	ACTION/REMARKS
74	2021	Student selects MENUS from INDEX MENU.
75	2023	Student selects MISCELLANEOUS MENUS from MENUS.
76		Student selects POLAR COORD from MISCELLANEOUS MENU.
77		Student selects RELOAD POINT, option 1, from POLAR COORDINATES MENU.
78		FCP displays: 
79	2218	Student selects number 0 and presses EXEC.
80		FCP displays: 
81		There is a 30-second delay to simulate vehicle movement to RELOAD POINT.
82	2723	Student presses INDEX.
83	2721	Student selects MENUS from INDEX MENU.
84	2723	Student selects BOOM CONTROL MENU from MENUS.

**Basic Fire Mission (Program 210) - Continued**

SEQUENCE NO.	STEP NO. IN PROGRESS	ACTION/REMARKS
--------------	----------------------	----------------

85		Student selects LLM attitude for loading. LLM moves to selected position. BOOM CONT lights on FCP comes on. Student performs reload operation and presses LLM STOW. LAUNCHER STATUS MESSAGE TRANSMITTED appears for 5 seconds.
----	--	--------------------------------------------------------------------------------------------------------------------------------------------------------------------------------------------------------------------------------

86		FCP displays:
----	--	---------------

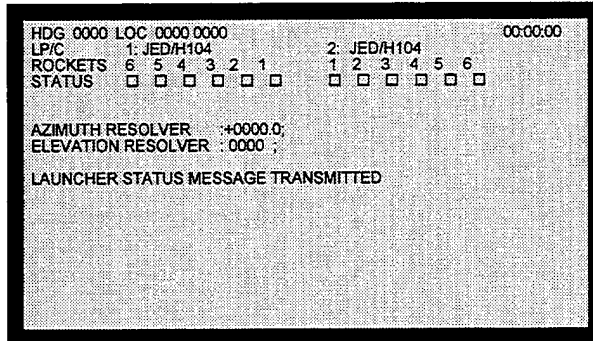

87		FCP displays:
----	--	---------------

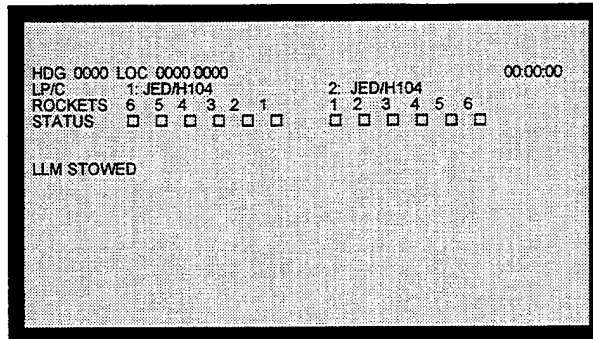

88	2915	Student presses INDEX.
89	2921	Student selects MENUS from INDEX MENU.
90	2923	Student selects MISCELLANEOUS MENU from MENUS.
91		Student selects POLAR COORD from MISCELLANEOUS MENU.
92		Student selects SURVEY CONTROL POINT, option 4, from POLAR COORDINATES MENU.

**Basic Fire Mission (Program 210) - Continued**

SEQUENCE NO.	STEP NO. IN PROGRESS	ACTION/REMARKS
--------------	----------------------	----------------

93		FCP displays:
----	--	---------------

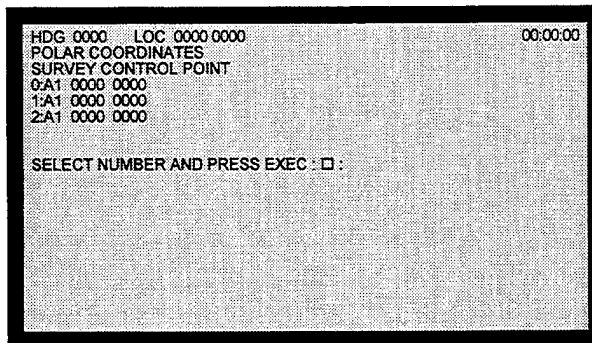

94	3118	Student selects number 0 and presses EXEC.
----	------	--------------------------------------------

95		FCP displays:
----	--	---------------

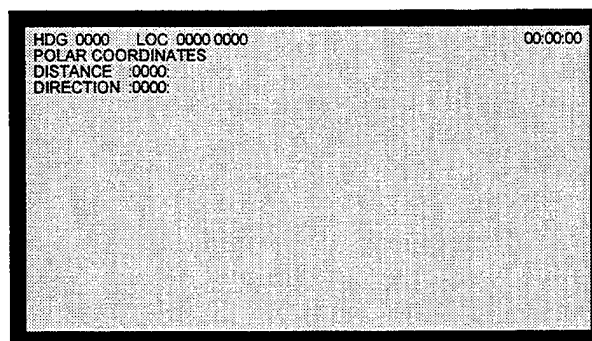

96		There is a 30-second delay to simulate vehicle movement to survey control point number 1. Vehicle heading changes.
----	--	--------------------------------------------------------------------------------------------------------------------

97	3323	Student presses INDEX.
----	------	------------------------

98	3321	Student selects MENUS from INDEX MENU.
----	------	----------------------------------------

99	3323	Student selects SRP/PDS MENU from MENUS.
----	------	------------------------------------------

100		Student selects CALIBRATE PDS from SRP/PDS MENU.
-----	--	--------------------------------------------------

**Basic Fire Mission (Program 210) - Continued**

SEQUENCE NO.	STEP NO. IN PROGRESS	ACTION/REMARKS
--------------	----------------------	----------------

101 FCP displays:

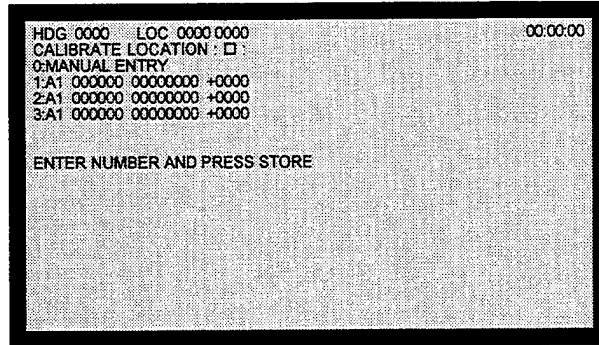

102 Student selects option 1 and presses STORE.

103 FCP displays:

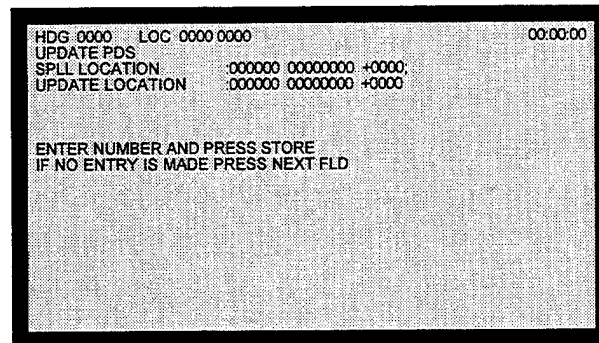

104 3518 Student presses NEXT FLD.

105 FCP displays:

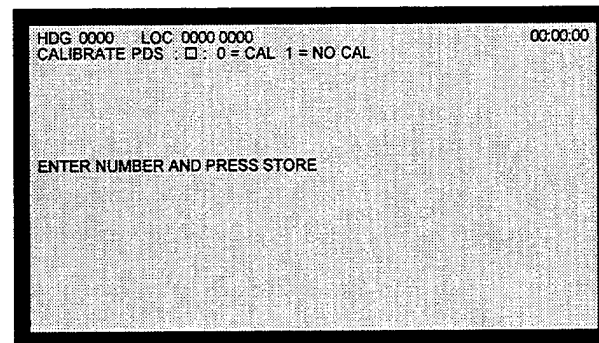

106 3524 Student selects option 0 = CAL and presses STORE.

**Basic Fire Mission (Program 210) - Continued**

SEQUENCE NO.	STEP NO. IN PROGRESS	ACTION/REMARKS
--------------	----------------------	----------------

107 FCP displays:

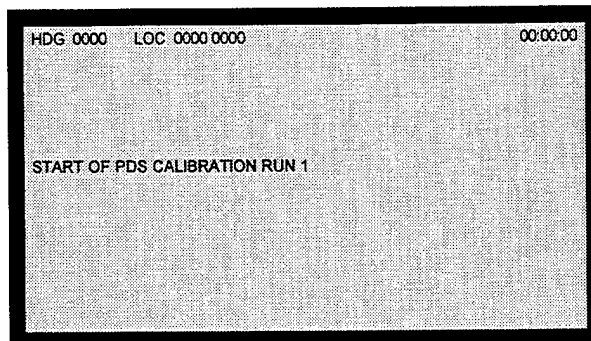

108 There is a 30-second delay to simulate vehicle movement to SCP number 2. Vehicle heading changes.

109 3718 Student presses INDEX.

110 3721 Student selects MENUS from INDEX MENU.

111 3723 Student selects SRP/PD MENU from MENUS.

112 Student selects CALIBRATE PDS from SRP/PDS MENU.

113 FCP displays:

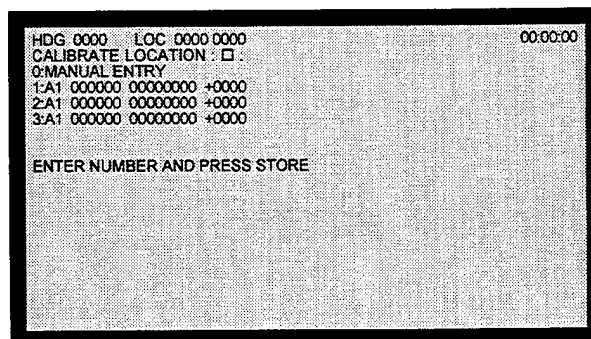

114 Student selects option 2 and presses STORE.

**Basic Fire Mission (Program 210) - Continued**

SEQUENCE NO.	STEP NO. IN PROGRESS	ACTION/REMARKS
--------------	----------------------	----------------

115 FCP displays:

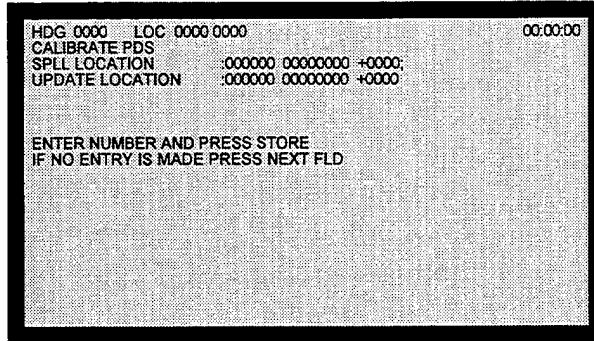

116 3918 Student presses NEXT FLD.

117 FCP displays:

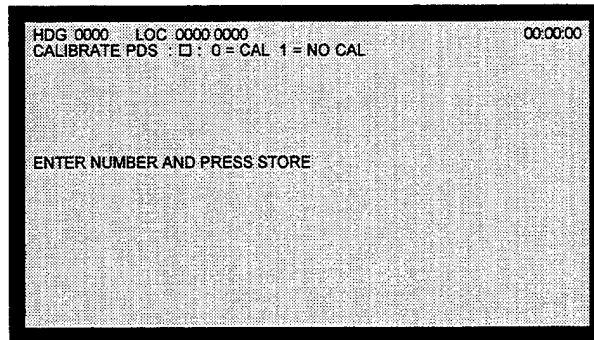

118 3924 Student selects 0 = CAL and presses STORE.

119 FCP displays:

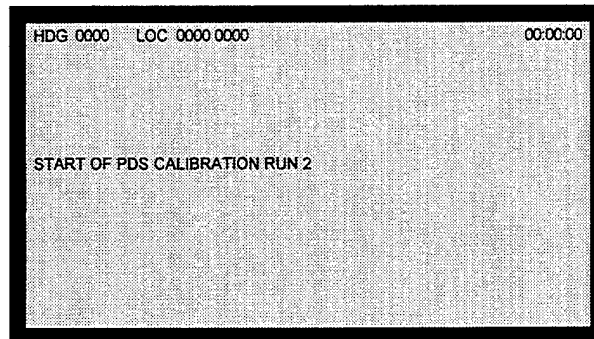

120 There is a 30-second to simulate movement of vehicle back to first SCP.

121 4118 Student presses INDEX.

**Basic Fire Mission (Program 210) - Continued**

SEQUENCE NO.	STEP NO. IN PROGRESS	ACTION/REMARKS
122	4121	Student selects MENUS from INDEX MENU.
123	4123	Student selects SRP/PDS MENU from MENUS.
124		Student selects CALIBRATE PDS from SRP/PDS MENU.
125		FCP displays:

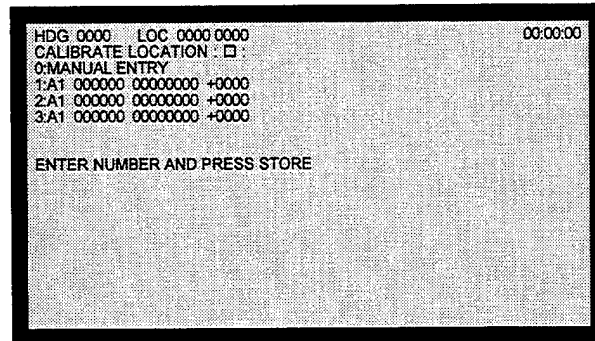

126 Student selects option 1 and presses STORE.

127 FCP displays:

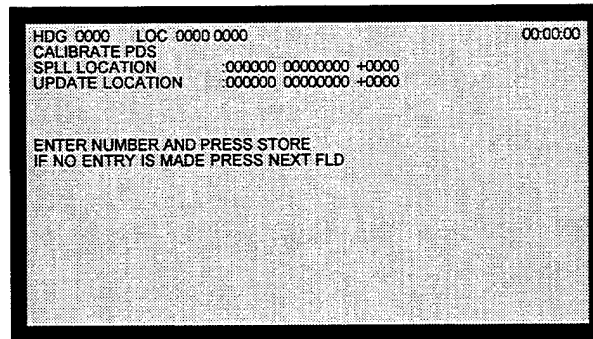

128 4318 Student presses NEXT FLD.

**Basic Fire Mission (Program 210) - Continued**

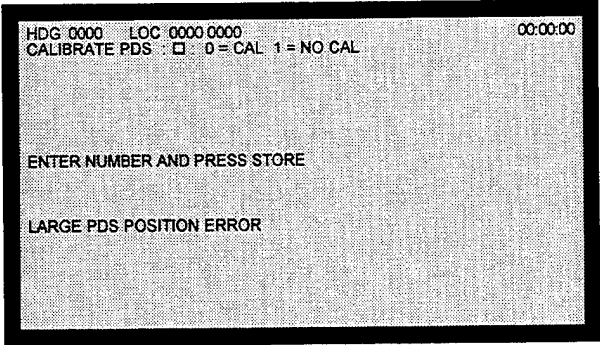
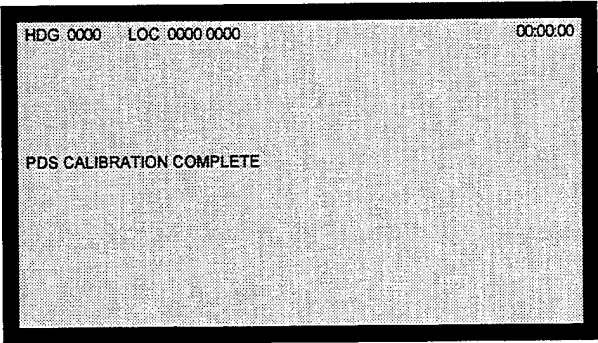
<b>SEQUENCE NO.</b>	<b>STEP NO. IN PROGRESS</b>	<b>ACTION/REMARKS</b>
129		FCP displays: 
130	4324	Student selects 0 = CAL and presses STORE.
131		FCP displays: 
132	4418	Student presses INDEX.
133	4421	Student selects MENUS from INDEX MENU.
134	4423	Student selects MISCELLANEOUS MENU from MENUS.
135		Student selects POLAR COORD from MISCELLANEOUS MENU.
136		Student selects HIDE POINT, option 5, from POLAR COORDINATES MENU.

**Basic Fire Mission (Program 210) - Continued**

SEQUENCE NO.	STEP NO. IN PROGRESS	ACTION/REMARKS
--------------	----------------------	----------------

137		FCP displays:
-----	--	---------------

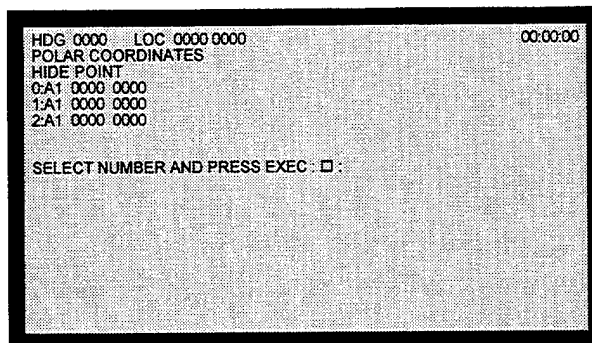

138	4618	Student selects number 0 and presses EXEC.
-----	------	--------------------------------------------

139		FCP displays:
-----	--	---------------

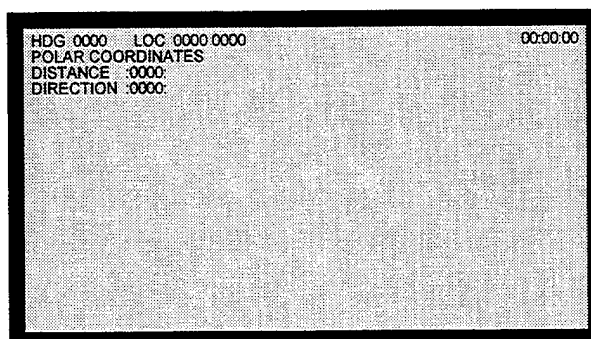

140		The display is the distance and direction from the current launcher location to grid coordinates of the hide point.
-----	--	---------------------------------------------------------------------------------------------------------------------

141		There is a 30-second delay to simulate vehicle movement to the hide point.
-----	--	----------------------------------------------------------------------------

142	5016	Student presses INDEX.
-----	------	------------------------

143	5021	Student selects MENU from INDEX MENU.
-----	------	---------------------------------------

144	5023	Student selects SRP/PDS MENU from MENUS.
-----	------	------------------------------------------

145		Student selects START SPLL COOL/HOT, option 2, from SRP/PDS MENU.
-----	--	-------------------------------------------------------------------

*Basic Fire Mission (Program 210) - Continued*

---

SEQUENCE NO.	STEP NO. IN PROGRESS	ACTION/REMARKS
--------------	----------------------	----------------

---

146 FCP displays:

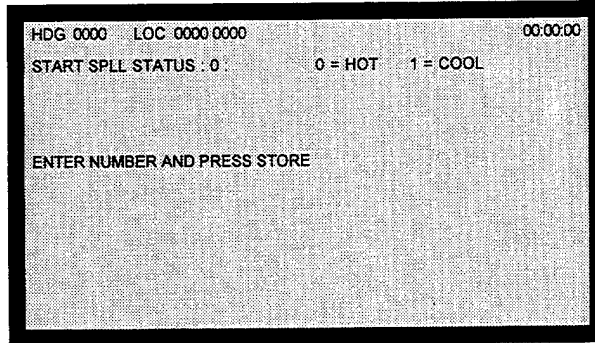

147 Student selects COOL, option 1, from START SPLL, STATUS MENU.

148 FCP displays LAUNCHER STATUS MESSAGE TRANSMITTED for 5 seconds.

149 The SRP/PDS is turned off and the launcher location field disappears from the display.

150 Lesson is terminated.

**Distributed Interactive Simulation (DIS) Fire When Ready (FWR) Fire Mission (Experimental Simulation Scenario).** This mission starts with a fully loaded vehicle parked at location 562520 03833260 with the weapon system powered up and all STARTUP data entered. The purpose of the mission is to allow signal PDUs to be received to control free play during a fire mission.

Initial conditions:                   MODE Switch in INSTRUCTOR  
                                           SYS PWR Switch on FCP - ON  
                                           PLU Switch DISCONNECTED  
                                           ARM Switch on FCP - SAFE

**DIS Fire When Ready (FWR) Fire Mission (Experimental Simulation Scenario)**

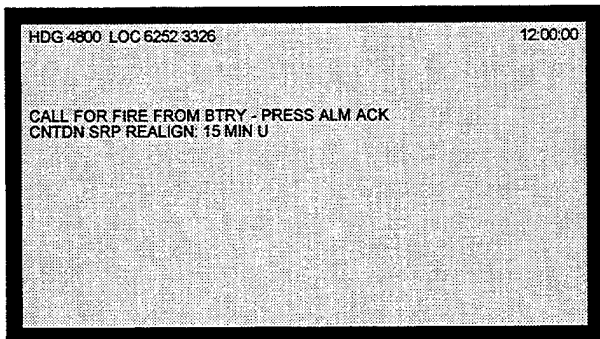
SEQUENCE NO.	STEP NO. IN PROGRESS	ACTION/REMARKS
1		Student verifies prompt ENTER LESSON NUMBER. 000 is displayed.
2		Student enters 199 on FCP keypad and verifies ENTER LESSON NUMBER. 199 is displayed.
3		Student places MODE switch to STUDENT and observes prompt on display will blink and then be redisplayed. Student verifies SYS PWR light ON; SRP RDY light ON.
4		FCP displays:
		
5		Student presses ALM ACK key on FCP keypad and verify the following prompts
6		WILL COMPLY MESSAGE READY - PRESS XMIT appears on FCP.

**DIS Fire When Ready (FWR) Fire Mission (Experimental Simulation Scenario) - Cont'd**

SEQUENCE NO.	STEP NO. IN PROGRESS	ACTION/REMARKS
--------------	----------------------	----------------

7 FCP displays:

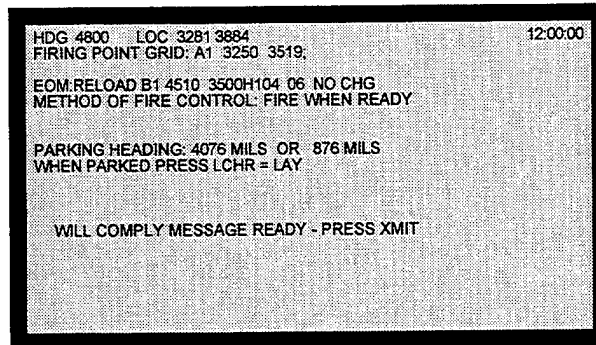

8 Student presses XMIT

9 Student presses INDEX

10 FCP displays INDEX MENU.

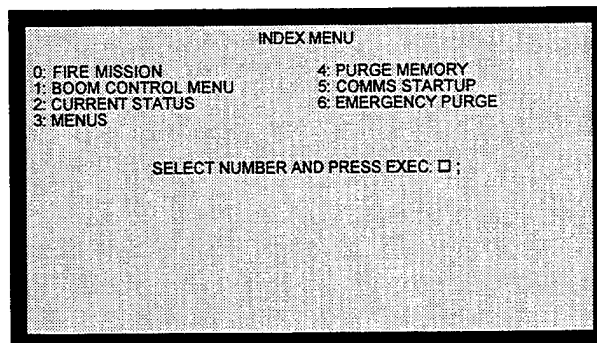

11 Student selects MENUS and presses EXEC key.

**DIS Fire When Ready (FWR) Fire Mission (Experimental Simulation Scenario) - Cont'd**

<b>SEQUENCE NO.</b>	<b>STEP NO. IN PROGRESS</b>	<b>ACTION/REMARKS</b>
---------------------	-----------------------------	-----------------------

12 FCP displays MENUS.

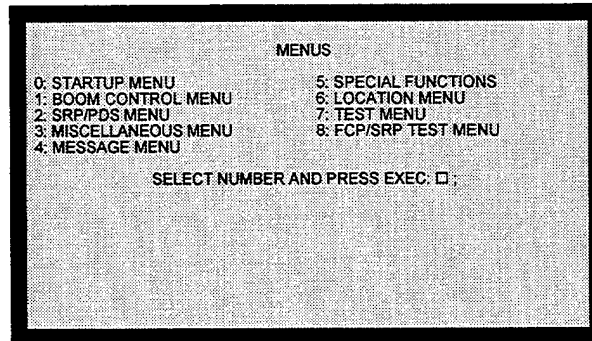

13 Student selects MISCELLANEOUS MENU and presses EXEC key.

14 Student selects POLAR COORD from MISCELLANEOUS MENU.

15 Student selects FIRING POINT, option 0, from POLAR COORDINATES MENU.

16 FCP displays:

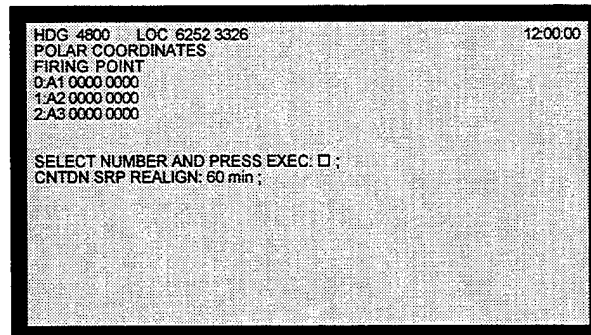

17 Student moves to fire position by pressing MOVE VEHICLE button at top of panel. There is a 30-second delay to simulate vehicle movement to firing point.

18 After arriving at the firing point, student presses INDEX.

**DIS Fire When Ready (FWR) Fire Mission (Experimental Simulation Scenario) - Cont'd**

SEQUENCE NO.	STEP NO. IN PROGRESS	ACTION/REMARKS
--------------	----------------------	----------------

19 FCP displays INDEX MENU.

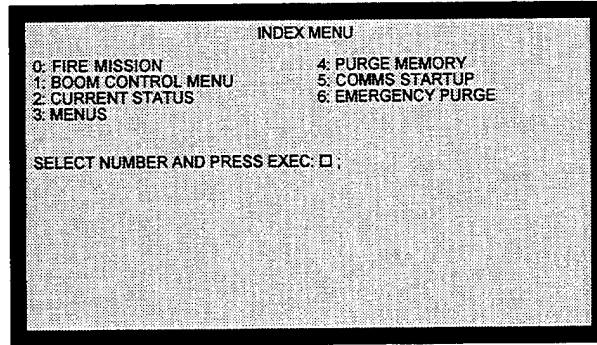

20 Student selects CURRENT STATUS from INDEX MENU.

21 Student presses LCHR LAY key.

22 FCP displays:

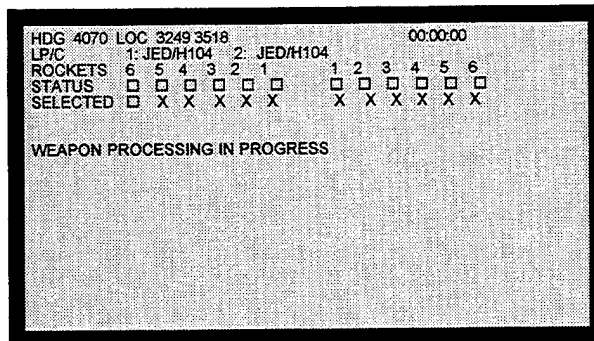

23 There is a standard delay for weapons processing.

24 FCP displays:

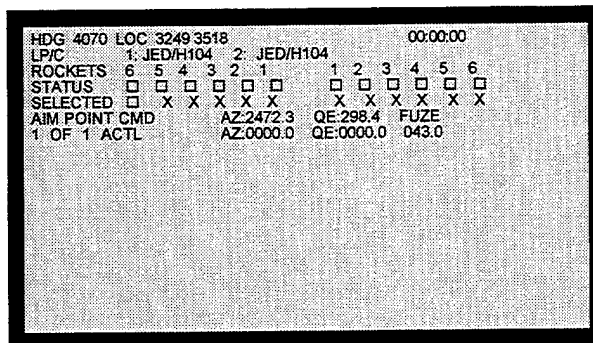

**DIS Fire When Ready (FWR) Fire Mission (Experimental Simulation Scenario) - Cont'd**

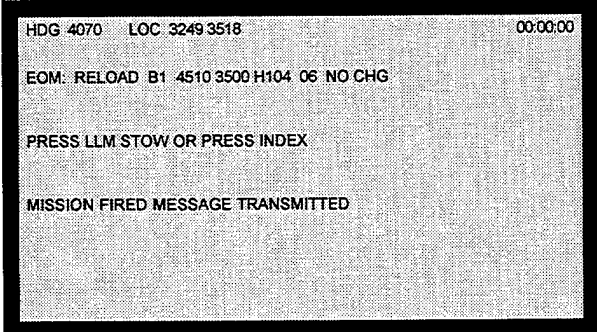
SEQUENCE NO.	STEP NO. IN PROGRESS	ACTION/REMARKS
25		After LLM reaches AIM POINT, Student verifies ARM ROCKETS prompt is displayed.
26		Student places ARM switch on FCP to ARM position and verifies SAFE light is OFF and ARM light is ON. ARM ROCKETS prompt is replaced by FIRE ROCKETS.
27		Student actuates FIRE switch by placing ARM switch to the ARM position and holding it there until the FIRE light goes on.
28		Student verifies 6 rockets are fired at approximately 6-second intervals.
29		SAFE ROCKETS END OF MISSION prompt will be displayed when all rockets have been fired.
30		Student places ARM switch to SAFE.
31		MISSION FIRED MESSAGE TRANSMITTED will be displayed for 5 seconds.
32		FCP displays:
		
33		Student presses LLM STOW. LLM begins to stow.  AZIMUTH RESOLVER:  ELEVATION RESOLVER:
34		There is a standard delay to simulate stowing.
35	4418	Student presses INDEX.
36	4421	Student selects MENUS from INDEX MENU.
37	4423	Student selects MISCELLANEOUS MENU from MENUS.

**DIS Fire When Ready (FWR) Fire Mission (Experimental Simulation Scenario) - Cont'd**

SEQUENCE NO.	STEP NO. IN PROGRESS	ACTION/REMARKS
38		Student selects POLAR COORD from MISCELLANEOUS MENU.
39		Student selects HIDE POINT, option 5, from POLAR COORDINATES MENU.
40		FCP displays:

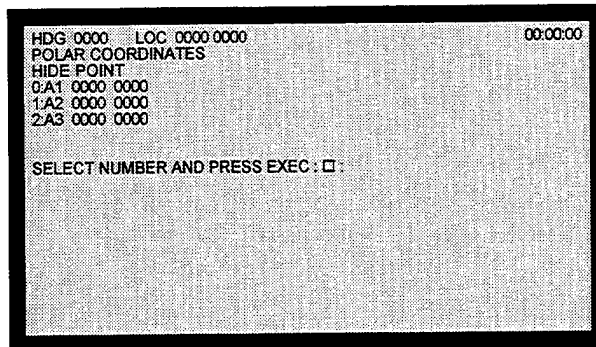

41 4618 Student selects number 1 and presses EXEC.

42 FCP displays:

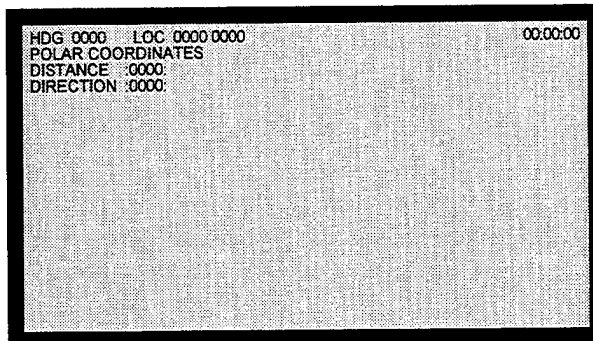

43 The display is the distance and direction from the current launcher location to grid coordinates of the hide point.

44 Student moves to fire position by pressing MOVE VEHICLE button at top of panel. There is a 30-second delay to simulate vehicle movement to the hide point.

45 Student arrives at hide point and waits to receive next fire mission.

**DIS Fire When Ready (FWR) Fire Mission (Experimental Simulation Scenario) - Cont'd**

<b>SEQUENCE NO.</b>	<b>STEP NO. IN PROGRESS</b>	<b>ACTION/REMARKS</b>
---------------------	-----------------------------	-----------------------

46 FCP displays:

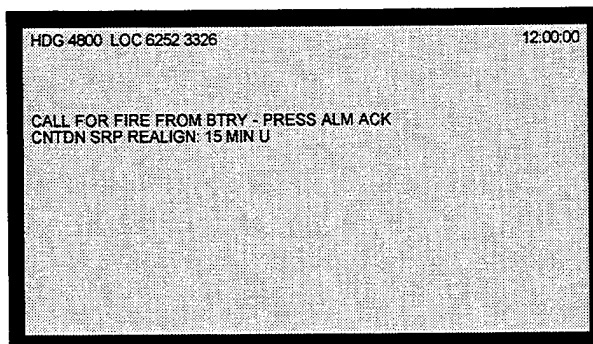

47 Student presses ALM ACK key on FCP keypad and verifies the following prompts:

48 WILL COMPLY MESSAGE READY - PRESS XMIT appears on FCP.

49 FCP displays:

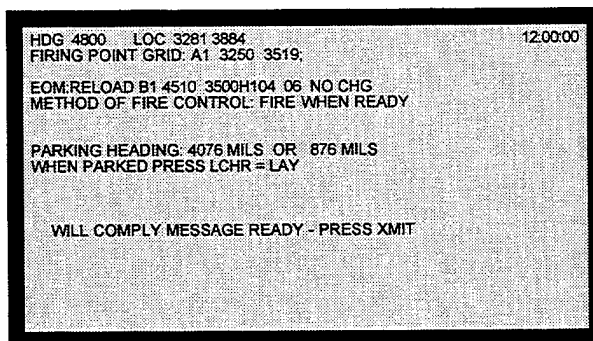

50 Student presses XMIT

51 Student presses INDEX

**DIS Fire When Ready (FWR) Fire Mission (Experimental Simulation Scenario) - Cont'd**

SEQUENCE NO.	STEP NO. IN PROGRESS	ACTION/REMARKS
--------------	----------------------	----------------

52 FCP displays INDEX MENU.

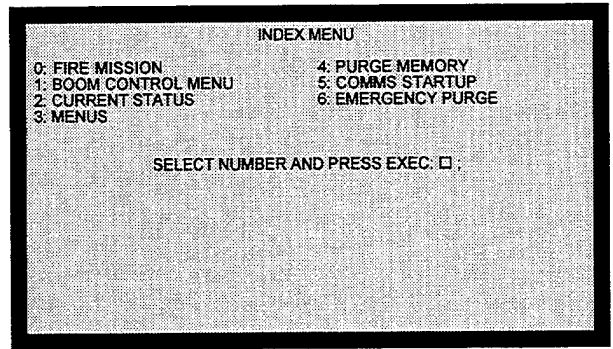

52 Student selects MENUS and presses EXEC key.

53 FCP displays MENUS.

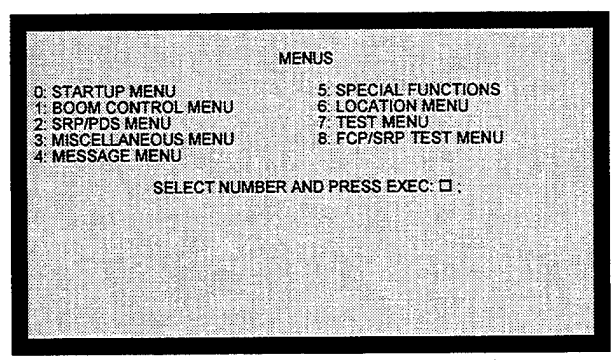

54 Student selects MISCELLANEOUS MENU and presses EXEC key.

55 Student selects POLAR COORD from MISCELLANEOUS MENU.

56 Student selects FIRING POINT, option 1, from POLAR COORDINATES MENU.

**DIS Fire When Ready (FWR) Fire Mission (Experimental Simulation Scenario) - Cont'd**

SEQUENCE NO.	STEP NO. IN PROGRESS	ACTION/REMARKS
--------------	----------------------	----------------

57 FCP displays:

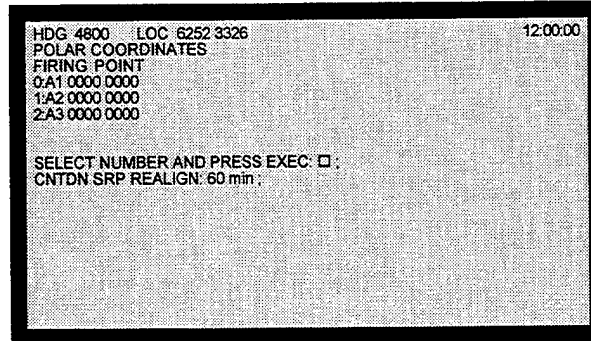

58 Student moves to fire position by pressing MOVE VEHICLE button at top of panel. There is a 30-second delay to simulate vehicle movement to firing point.

59 After arriving at the firing point, student presses INDEX.

60 FCP displays INDEX MENU.

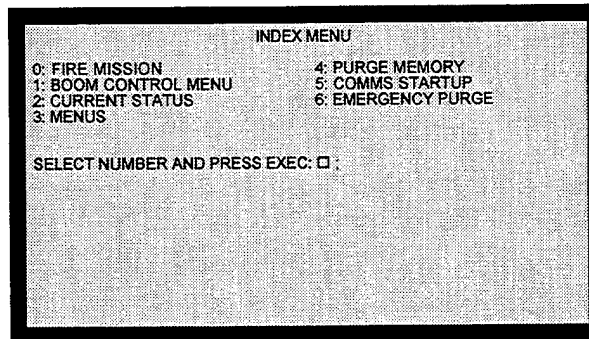

61 Student selects CURRENT STATUS from INDEX MENU.

62 Student presses LCHR LAY key.

**DIS Fire When Ready (FWR) Fire Mission (Experimental Simulation Scenario) - Cont'd**

SEQUENCE NO.	STEP NO. IN PROGRESS	ACTION/REMARKS
--------------	----------------------	----------------

63 FCP displays:

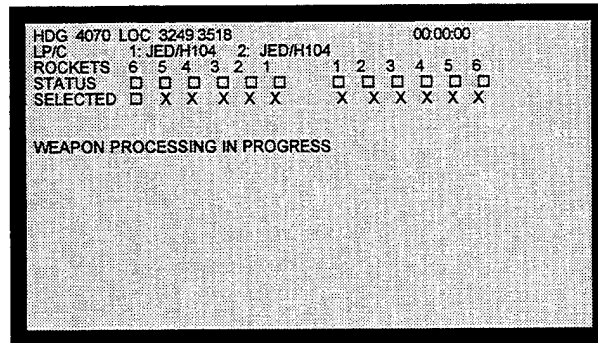

64 There is a standard delay for weapons processing.

65 FCP displays:

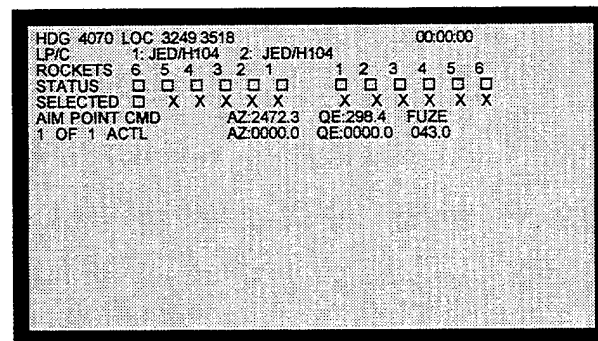

66 After LLM reaches AIM POINT, student verifies ARM ROCKETS prompt is displayed.

67 Student places ARM switch on FCP to ARM position and verifies SAFE light is OFF and ARM light is ON. ARM ROCKETS prompt is replaced by FIRE ROCKETS.

68 Student actuates FIRE switch by placing ARM switch to the ARM position and holding it there until the FIRE light goes on.

69 Student verifies 6 rockets are fired at approximately 6-second intervals.

70 SAFE ROCKETS END OF MISSION prompt will be displayed when all rockets have been fired.

**DIS Fire When Ready (FWR) Fire Mission (Experimental Simulation Scenario) - Cont'd**

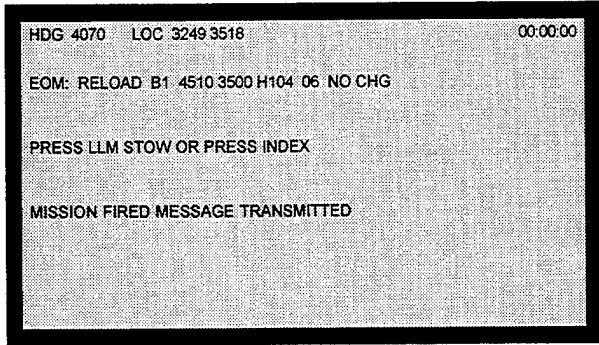
SEQUENCE NO.	STEP NO. IN PROGRESS	ACTION/REMARKS
71		Student places ARM switch to SAFE.
72		MISSION FIRED MESSAGE TRANSMITTED will be displayed for 5 seconds.
73		FCP displays:
		
74		Student presses LLM STOW. LLM begins to stow.  AZIMUTH RESOLVER:  ELEVATION RESOLVER:
75		There is a standard delay to simulate stowing.
76		Lesson ends, FCP screen goes blank.



APPENDIX C  
BIOGRAPHICAL DATA COLLECTION FORM AND QUESTIONNAIRE

Biographical Data Collection Form

Data Required by the Privacy Act

AUTHORITY: Title 10, United States Code, Section 3012

ROUTINE USES: Identification of educational, aptitude, and experience backgrounds of MLRS trainees. This information will only be released to agencies with direct involvement in the project, or with a need to know about the FCPT findings, and then only in the form of statistical summaries or graphs.

Today's Date:     /     / 94

Name: \_\_\_\_\_ Rank: \_\_\_\_\_

MOS: \_\_\_\_\_ If you know it, enter your GT Score \_\_\_\_\_

Primary: \_\_\_\_\_

Secondary: \_\_\_\_\_

Duty: \_\_\_\_\_

SSN: \_\_\_\_\_ - \_\_\_\_\_ - \_\_\_\_\_ Age: \_\_\_\_\_

Current Organization \_\_\_\_\_

Completed NCO Academy?     Yes / No

Education Level: 6 7 8 9 10 11 12 13 14 15 16  
(GED: Circle 12)                   High School College

Duty Position on the MLRS: \_\_\_\_\_

How many months? \_\_\_\_\_

Previous training on the MLRS?     Yes / No     Explain

briefly: \_\_\_\_\_

\_\_\_\_\_

\_\_\_\_\_

How many total months of training on the MLRS? \_\_\_\_\_

PRINCIPAL PURPOSE(S): To investigate the utility of the FCPT training device in a distributed, interactive simulation and to compare those findings to biographical information as appropriate.

Please **CIRCLE** the number that best reflects your opinion.

1. The training on this device was a waste of time:

<b>Strongly</b>						<b>Strongly</b>
<b>Agree</b>	1	2	3	4	5	<b>Disagree</b>

2. This training help prepare me for later training in the school:

<b>Strongly</b>						<b>Strongly</b>
<b>Agree</b>	1	2	3	4	5	<b>Disagree</b>

3. All simulators are worthless:

<b>Strongly</b>						<b>Strongly</b>
<b>Agree</b>	1	2	3	4	5	<b>Disagree</b>

4. I wish that I could have had more training time on the device:

<b>Strongly</b>						<b>Strongly</b>
<b>Agree</b>	1	2	3	4	5	<b>Disagree</b>

5. I would not recommend to the section chief that soldiers be trained on this device:

<b>Strongly</b>						<b>Strongly</b>
<b>Agree</b>	1	2	3	4	5	<b>Disagree</b>

6. The FCPT is an important training device:

<b>Strongly</b>						<b>Strongly</b>
<b>Agree</b>	1	2	3	4	5	<b>Disagree</b>

7. Due to the training on this device, I think I will be **more** confused when I get in an MLRS:

<b>Strongly</b>						<b>Strongly</b>
<b>Agree</b>	1	2	3	4	5	<b>Disagree</b>

8. The **only** way to learn something is to use the real thing, not a simulator:

<b>Strongly</b>						<b>Strongly</b>
<b>Agree</b>	1	2	3	4	5	<b>Disagree</b>

9. I liked this training device because:

10. I did not like this training device because:

**Biographical Data Collection Form**

Data Required by the Privacy Act

AUTHORITY: Title 10, United States Code, Section 3012

ROUTINE USES: Identification of educational, aptitude, and experience backgrounds of MLRS trainees. This information will only be released to agencies with direct involvement in the project, or with a need to know about the FCPT findings, and then only in the form of statistical summaries or graphs.

Today's Date:    /        / 94

Name: \_\_\_\_\_ Rank: \_\_\_\_\_

MOS: \_\_\_\_\_ If you know it, enter your GT Score \_\_\_\_\_  
Primary: \_\_\_\_\_  
Secondary: \_\_\_\_\_  
Duty: \_\_\_\_\_

SSN: \_\_\_\_\_ - \_\_\_\_\_ - \_\_\_\_\_ Age: \_\_\_\_\_

Current Organization \_\_\_\_\_

Completed NCO Academy?        Yes / No

Education Level: 6 7 8 9 10 11 12 13 14 15 16  
(GED: Circle 12)                      High School College

Duty Position on the MLRS: \_\_\_\_\_

How many months? \_\_\_\_\_

Previous training on the MLRS?        Yes / No        Explain

briefly: \_\_\_\_\_  
\_\_\_\_\_  
\_\_\_\_\_

When did you last train on the FCP in a SPLL? \_\_\_\_\_

How many total months of training on the MLRS? \_\_\_\_\_

PRINCIPAL PURPOSE(S): To investigate the utility of the FCPT training device in a distributed, interactive simulation and to compare those findings to biographical information as appropriate.

Please **CIRCLE** the number that best reflects your opinion.

1. The training on this device was a waste of time:  
**Strongly Agree**      1                      2                      3                      4                      5                      **Strongly Disagree**
2. This device is a nice addition to classroom training:  
**Strongly Agree**      1                      2                      3                      4                      5                      **Strongly Disagree**
3. All simulators are worthless:  
**Strongly Agree**      1                      2                      3                      4                      5                      **Strongly Disagree**
4. More time should be spent training on this device:  
**Strongly Agree**      1                      2                      3                      4                      5                      **Strongly Disagree**
5. I do not recommend that soldiers be trained on this device:  
**Strongly Agree**      1                      2                      3                      4                      5                      **Strongly Disagree**
6. The FCPT is appropriate for new trainees:  
**Strongly Agree**      1                      2                      3                      4                      5                      **Strongly Disagree**
7. The FCPT should be used only after classroom training:  
**Strongly Agree**      1                      2                      3                      4                      5                      **Strongly Disagree**
8. The **only** way to learn something is to use the real thing, not a simulator:  
**Strongly Agree**      1                      2                      3                      4                      5                      **Strongly Disagree**
9. The FCPT is **only** appropriate for soldiers to maintain their skill level on the MLRS FCP:  
**Strongly Agree**      1                      2                      3                      4                      5                      **Strongly Disagree**
10. The FCPT looks and operates like the real MLRS FCP:  
**Strongly Agree**      1                      2                      3                      4                      5                      **Strongly Disagree**
11. This device may give the soldiers a **false** sense of confidence about using the MLRS FCP:  
**Strongly Agree**      1                      2                      3                      4                      5                      **Strongly Disagree**

12. I liked this training device because:

13. I did not like this training device because:

14. Does the desktop FCPT make learning any FCP tasks **easier** compared to the institutional trainer? If so, which tasks?

15. Does the desktop FCPT make learning any FCP tasks **harder** compared to the institutional trainer? If so, which tasks?

16. Please answer Q's 14 and 15 again, this time comparing the desktop FCPT to the FCP in the SPLL:

17. Regarding training in the *distributed, interactive simulation* (DIS), what advantages does it have over the institutional, classroom situation? What combat situations (if any) could be trained on the desktop FCPT in the DIS that could not be trained in the classroom or on the desktop FCPT operating as a stand-alone device?

18. How does operating in the DIS change the training of men at higher levels of command? What SPLL information might be passed over the DIS to aid their overall understanding of SPLL operations?

19. Could you identify a particular type of gunner trainee that would benefit from training on the desktop FCPT in the DIS? How would he differ from other soldiers?

20. Could you identify another type of gunner trainee that would be negatively affected by training on the desktop FCPT in the DIS? What are his qualities?

APPENDIX D  
OBSERVATIONAL DATA COLLECTION FORM

**Observational Data Collection Form**

Date: \_\_\_\_\_ Time: \_\_\_\_\_ Observer Initials: \_\_\_\_\_

**Error Codes:**

- 1 = wrong key pressed (indicate which key was incorrectly pressed.
- 2 = pressed correct key, but very slow
- 3 = pressed correct key, but before prompted to do so
- 4 = skipped step # \_\_\_\_\_ (include step# skipped, see instruction sheet)
- 5 =

	Corresponding # on instruction sheet	Error Code (1 2 3 4 or 5)	Notes
<b>Run #1</b>			
mission 1			
mission 2			
<b>Run #2</b>			
mission 1			
mission 2			
<b>Run #3</b>			
mission 1			
mission 2			

<u>NO. OF COPIES</u>	<u>ORGANIZATION</u>	<u>NO. OF COPIES</u>	<u>ORGANIZATION</u>
1	DIRECTORATE FOR MANPRINT ATTN HQDA (DAPE MR) DEPUTY CHIEF OF STAFF PERSONNEL 300 ARMY PENTAGON WASHINGTON DC 20310-0300	1	COMMANDER US ARMY MATERIEL COMMAND ATTN AMCAM 5001 EISENHOWER AVENUE ALEXANDRIA VA 22333-0001
1	DIRECTOR ARMY AUDIOLOGY & SPEECH CENTER WALTER REED ARMY MEDICAL CENTER WASHINGTON DC 20307-5001	1	COMMANDER USA OPERATIONAL T&E AGENCY ATTN CSTE TSM 4501 FORD AVENUE ALEXANDRIA VA 22302-1458
1	OUSD(A)/DDDR&E(R&A)/E&LS PENTAGON ROOM 3D129 WASHINGTON DC 20301-3080	1	USA BIOMEDICAL RSCH & DEV LAB ATTN LIBRARY FORT DETRICK BUILDING 568 FREDERICK MD 21702-5010
1	CODE 1142PS OFFICE OF NAVAL RESEARCH 800 N QUINCY STREET ARLINGTON VA 22217-5000	1	HQ USAMRDC ATTN SGRD PLC FORT DETRICK MD 21701
1	WALTER REED ARMY INST OF RESEARCH ATTN SGRD UWI C (COL REDMOND) WASHINGTON DC 20307-5100	1	COMMANDER USA AEROMEDICAL RESEARCH LAB ATTN LIBRARY FORT RUCKER AL 36362-5292
1	DR ARTHUR RUBIN NATL INST OF STANDARDS & TECH BUILDING 226 ROOM A313 GAITHERSBURG MD 20899	1	US ARMY SAFETY CENTER ATTN CSSC SE FORT RUCKER AL 36362
1	COMMANDER US ARMY RESEARCH INSTITUTE ATTN PERI ZT (DR EDGAR M JOHNSON) 5001 EISENHOWER AVENUE ALEXANDRIA VA 22333-5600	1	CHIEF ARMY RESEARCH INSTITUTE AVIATION R&D ACTIVITY ATTN PERI IR FORT RUCKER AL 36362-5354
1	DEFENSE LOGISTICS STUDIES INFORMATION EXCHANGE US ARMY LOG MGMT COLLEGE FORT LEE VA 23801-6034	2	DIRECTOR US ARMY RESEARCH LABORATORY ATTN AMSRL OP SD TL (TECH LIB) ADELPHI MD 20783-1145
1	DEPUTY COMMANDING GENERAL ATTN EXS (Q) MARINE CORPS RD&A COMMAND QUANTICO VA 22134	1	TECHNICAL INFORMATION CENTER HQs TRADOC TEST & EXPERIMENTATION COMMAND EXPERIMENTATION CENTER BLDG 2925 FORT ORD CA 93941-7000
1	HEADQUARTERS USATRADOC ATTN ATCD SP FORT MONROE VA 23651	1	US ARMY NATICK RD&E CENTER ATTN STRNC YBA NATICK MA 01760-5020
1	COMMANDER USATRADOC COMMAND SAFETY OFFICE ATTN ATOS (MR PESSAGNO MR LYNE) FORT MONROE VA 23651-5000		

<u>NO. OF COPIES</u>	<u>ORGANIZATION</u>	<u>NO. OF COPIES</u>	<u>ORGANIZATION</u>
1	US ARMY TROOP SUPPORT COMMAND NATICK RD&E CENTER ATTN BEHAVIORAL SCIENCES DIV SSD NATICK MA 01760-5020	1	COMMANDER WHITE SANDS MISSILE RANGE ATTN STEWS TE RE WHITE SANDS MISSILE RANGE NM 88002
1	US ARMY TROOP SUPPORT COMMAND NATICK RESEARCH DEVELOPMENT AND ENGINEERING CENTER ATTN TECH LIBRARY (STRNC MIL) NATICK MA 01760-5040	1	COMMANDER WHITE SANDS MISSILE RANGE ATTN TECHNICAL LIBRARY WHITE SANDS MISSILE RANGE NM 88002
1	HQ USA RESEARCH INST OF ENVIRONMENTAL MEDICINE ATTN MEDRI CL (DR J KOBRICK) NATICK MA 01760-5007	1	USA TRADOC ANALYSIS COMMAND ATTN ATRC WSR (D ANGUIANO) WHITE SANDS MISSILE RANGE NM 88002-5502
1	DR RICHARD JOHNSON HEALTH & PERFORMANCE DIVISION US ARIEM NATICK MA 01760-5007	1	STRICOM 12350 RESEARCH PARKWAY ORLANDO FL 32826-3276
1	LOCKHEED SANDERS INC BOX MER-24-1583 NASHUA NH 03061-0868	1	COMMANDER USA TANK-AUTOMOTIVE R&D CENTER ATTN AMSTA RS/D REES WARREN MI 48090
1	ATTN DR F WESLEY BAUMGARDNER USAF ARMSTRONG LABORATORY/CFTO SUSTAINED OPERATIONS BRANCH BROOKS AFB TX 78235-5000	1	COMMANDER USA TANK-AUTOMOTIVE R&D CENTER ATTN AMSTA TSL (TECH LIBRARY) WARREN MI 48397-5000
1	AFHRL/PRTS BROOKS AFB TX 78235-5601	1	COMMANDER USA COLD REGIONS TEST CENTER ATTN STECR TS A APO AP 96508-7850
1	DR JON FALLESEN ARI FIELD UNIT PO BOX 3407 FORT LEAVENWORTH KS 66027-0347	1	MR. JOHN HUNT GE BLDG 148-301 ROUTE 38 MOORESTOWN NJ 08057
1	COMMANDER USAMC LOGISTICS SUPPORT ACTIVITY ATTN AMXLS AE REDSTONE ARSENAL AL 35898-7466	2	ADMINISTRATOR DEFENSE TECHNICAL INFORMATION CENTER ATTN DTIC DDA 8725 JOHN J KINGMAN RD STE 0944 FT BELVOIR VA 22060-6218
1	ARI FIELD UNIT FORT KNOX BUILDING 2423 PERI IK FORT KNOX KY 40121-5620	1	US ARMY RSCH DEV STDZN GP-UK ATTN DR MIKE STOUT PSC 802 BOX 15 FPO AE 09499-1500
1	COMMANDANT USA ARTILLERY & MISSILE SCHOOL ATTN USAAMS TECH LIBRARY FORT SILL OK 73503	1	INSTITUTE FOR DEFENSE ANALYSES ATTN DR JESSE ORLANSKY 1801 N BEAUREGARD STREET ALEXANDRIA VA 22311

<u>NO. OF COPIES</u>	<u>ORGANIZATION</u>	<u>NO. OF COPIES</u>	<u>ORGANIZATION</u>
1	DR RICHARD W PEW BBN SYSTEMS AND TECHNOLOGY CORP 10 MOULTON STREET CAMBRIDGE MA 02138	1	DR TOM MALONE CARLOW ASSOCIATES INC SUITE 750 3141 FAIRVIEW PARK DRIVE FAIRFAX VA 22042
1	DR NANCY ANDERSON DEPARTMENT OF PSYCHOLOGY UNIVERSITY OF MARYLAND COLLEGE PARK MD 20742	1	DR NORMAN BADLER DEPARTMENT OF COMPUTER AND INFORMATION SCIENCE UNIVERSITY OF PENNSYLVANIA PHILADELPHIA PA 19104-6389
1	MR LARRY W AVERY BATTELLE PACIFIC NW LABS PO BOX 999 MAIL STOP K6-66 RICHLAND WA 99352	1	COMMANDER US ARMY RESEARCH INSTITUTE OF ENVIRONMENTAL MEDICINE NATICK MA 01760-5007
1	LIBRARY ESSEX CORPORATION SUITE 510 1430 SPRING HILL ROAD MCLEAN VA 22102-3000	1	DR DANIEL J POND BATTELLE PNL/K6-66 PO BOX 999 RICHLAND WA 99350
1	DR BEN B MORGAN DEPARTMENT OF PSYCHOLOGY UNIVERSITY OF CENTRAL FLORIDA PO BOX 25000 ORLANDO FL 32816	1	HQDA (DAPE-ZXO) ATTN DR FISCHL WASHINGTON DC 20310-0300
1	AFHRL/CA BROOKS AFB TX 78235	1	HUMAN FACTORS ENG PROGRAM DEPT OF BIOMEDICAL ENGINEERING COLLEGE OF ENG & COMPUTER SCIENCE WRIGHT STATE UNIVERSITY DAYTON OH 45435
1	DR ARTHUR S KAMLET BELL LABORATORIES 6200 EAST BROAD STREET COLUMBUS OH 43213	1	COMMANDER USA MEDICAL R&D COMMAND ATTN SGRD PLC (LTC JJ JAEGAR) FORT DETRICK MD 21701-5012
1	MR AJ ARNOLD STAFF PROJECT ENG HUMAN FACTORS DEPARTMENT GENERAL MOTORS SYSTEMS ENGINEERING 1 1151 CROOKS ROAD TROY MI 48084		PEO ARMAMENTS ATTN AMCPEO AR BUILDING 171 PICATINNY ARSENAL NJ 07806-5000
1	DR LLOYD A AVANT DEPARTMENT OF PSYCHOLOGY IOWA STATE UNIVERSITY AMES IA 50010	1	PEO AIR DEFENSE ATTN SFAE AD S US ARMY MISSILE COMMAND REDSTONE ARSENAL AL 35898-5750
1	DR PAUL R MCCRIGHT INDUSTRIAL ENGINEERING DEPARTMENT KANSAS STATE UNIVERSITY MANHATTA KS 66502	1	JON TATRO HUMAN FACTORS SYSTEM DESIGN BELL HELICOPTER TEXTRON INC PO BOX 482 MAIL STOP 6 FT WORTH TX 76101
1	DR MM AYOUB DIRECTOR INSTITUTE FOR ERGONOMICS RESEARCH TEXAS TECH UNIVERSITY LUBBOCK TX 79409		

<u>NO. OF COPIES</u>	<u>ORGANIZATION</u>	<u>NO. OF COPIES</u>	<u>ORGANIZATION</u>
1	DAVID ALDEN HUGHES SIMULATION SYSTEMS INC 5301 E RIVER RD MINNEAPOLIS MN 55421-1024	1	SOUTHCOM WASHINGTON FIELD OFC 1919 SOUTH EADS ST SUITE L09 AMC FAST SCIENCE ADVISER ARLINGTON VA 22202
1	OASD (FM&P) WASHINGTON DC 20301-4000	1	HQ US SPECIAL OPERATIONS COMMAND AMC FAST SCIENCE ADVISER ATTN SOSD MACDILL AIR FORCE BASE TAMPA FL 33608-0442
1	COMMANDER US ARMY MATERIEL COMMAND ATTN AMCDE AQ 5001 EISENHOWER AVENUE ALEXANDRIA VA 22333	1	HQ US ARMY EUROPE AND 7TH ARMY ATTN AEAGX SA OFFICE OF THE SCIENCE ADVISER APO AE 09014
1	COMMANDER MARINE CORPS SYSTEMS COMMAND ATTN CBGT QUANTICO VA 22134-5080	1	COMMANDER HQ 21ST THEATER ARMY AREA COMMAND AMC FAST SCIENCE ADVISER ATTN AERSA APO AE 09263
1	DIRECTOR AMC-FIELD ASSISTANCE IN SCIENCE & TECHNOLOGY ATTN AMC-FAST (RICHARD FRANSEEN) FT BELVOIR VA 22060-5606	1	COMMANDER HEADQUARTERS USEUCOM AMC FAST SCIENCE ADVISER UNIT 30400 BOX 138 APO AE 09128
1	COMMANDER US ARMY FORCES COMMAND ATTN FCDJ SA BLDG 600 AMC FAST SCIENCE ADVISER FT MCPHERSON GA 30330-6000	1	HQ V CORPS COMMAND GROUP UNIT #25202 AMC FAST SCIENCE ADVISER ATTN AETV SA APO AE 09079-0700
1	COMMANDER I CORPS AND FORT LEWIS AMC FAST SCIENCE ADVISER ATTN AFZH CSS FORT LEWIS WA 98433-5000	1	HQ 7TH ARMY TRAINING COMMAND UNIT #28130 AMC FAST SCIENCE ADVISER ATTN AETT SA APO AE 09114
1	HQ III CORPS & FORT HOOD OFFICE OF THE SCIENCE ADVISER ATTN AFZF CS SA FORT HOOD TX 76544-5056	1	COMMANDER HHC SOUTHERN EUROPEAN TASK FORCE ATTN AESE SA BUILDING 98 AMC FAST SCIENCE ADVISER APO AE 09630
1	COMMANDER U.S. ARMY NATIONAL TRAINING CENTER AMC FAST SCIENCE ADVISER ATTN AMXLA SA FORT IRWIN CA 92310	1	COMMANDER US ARMY PACIFIC AMC FAST SCIENCE ADVISER ATTN APSA FT SHAFTER HI 96858-5L00
1	COMMANDER HQ XVIII ABN CORPS & FORT BRAGG OFFICE OF THE SCI ADV BLDG 1-1621 ATTN AFZA GD FAST FORT BRAGG NC 28307-5000		

<u>NO. OF COPIES</u>	<u>ORGANIZATION</u>	<u>NO. OF COPIES</u>	<u>ORGANIZATION</u>
1	COMMANDER US ARMY JAPAN/IX CORPS UNIT 45005 ATTN APAJ SA AMC FAST SCIENCE ADVISERS APO AP 96343-0054	1	ARL LIBRARY BLDG 459
1	AMC FAST SCIENCE ADVISERS PCS #303 BOX 45 CS-SO APO AP 96204-0045	1	ARL SLAD ATTN AMSRL BS (DR JT KLOPCIC) BLDG 328 APG-AA
1	COMMANDER ALASKAN COMMAND ATTN SCIENCE ADVISOR (MR GRILLS) 6-900 9TH ST STE 110 ELMENDORF AFB ALASKA 99506	1	COMMANDER CHEMICAL BIOLOGICAL AND DEFENSE COMMAND ATTN AMSCB CI APG-EA
1	CDR & DIR USAE WATERWAYS EXPERIMENTAL STA ATTN CEWES IM MI R (AS CLARK CD DEPT #1153) 3909 HALLS FERRY ROAD VICKSBURG MS 39180-6199	1	USATECOM RYAN BUILDING APG-AA
1	DIRECTOR US ARMY RESEARCH LABORATORY ATTN AMSRL OP SD TP (TECH PUB) ADELPHI MD 20783-1145		
1	DIRECTOR US ARMY RESEARCH LABORATORY ATTN AMSRL OP SD TA (REC MGMT) ADELPHI MD 20783-1145		
1	DR SEHCHANG HAH DEPT OF BEHAVIORAL SCIENCES & LEADERSHIP BUILDING 601 ROOM 281 US MILITARY ACADEMY WEST POINT NEW YORK 10996-1784		
1	US ARMY RESEARCH INSTITUTE ATTN PERI IK (DOROTHY FINLEY) 2423 MORANDE STREET FORT KNOX KY 40121-5620		
5	CHIEF ARL HRED USAFAS FIELD ELEMENT ATTN AMSRL HR MF (L PIERCE) BLDG 3040 ROOM 220 FORT SILL OK 73503-5600		
	<u>ABERDEEN PROVING GROUND</u>		
5	US ARMY RESEARCH LABORATORY ATTN AMSRL OP AP L (TECH LIB) BLDG 305		