

PLASTEC REPORT R42

**SOLID-PHASE FORMING (COLD FORMING)
OF PLASTICS**



DEPARTMENT OF DEFENSE
PLASTICS TECHNICAL EVALUATION CENTER
PICATINNY ARSENAL, DOVER, N. J.

JANUARY 1972

19960502 145

PLASTEC

Approved for public release; distribution unlimited.

PLASTICS TECHNICAL EVALUATION CENTER

DTIC QUALITY INSPECTED 1

PICATINNY ARSENAL
DOVER, NEW JERSEY

PLASTEC 17837

DISCLAIMER NOTICE

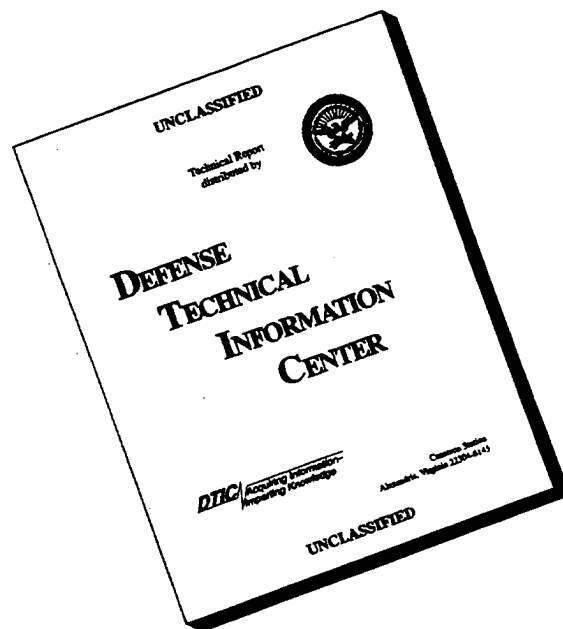

THIS DOCUMENT IS BEST QUALITY AVAILABLE. THE COPY FURNISHED TO DTIC CONTAINED A SIGNIFICANT NUMBER OF PAGES WHICH DO NOT REPRODUCE LEGIBLY.

THE PLASTICS TECHNICAL EVALUATION CENTER

Authorized by the Office of Director of Defense Research and Engineering, the Plastics Technical Evaluation Center (PLASTE^C) evaluates and disseminates technical information on current development, engineering, and application work in the field of plastics, reinforced plastics, and adhesives. It engages in materials surveys and other special assignments, and provides the Department of Defense with technical data and advice on research and development programs on plastics.

Both government and industry may request information from this Center directly. Inquiries which can be handled routinely are accomplished without charge. Those which require time-consuming study on the part of a specialist are charged for at a sum arrived at by prior agreement between requester and PLASTE^C.

In order to recover the costs of publication of its documents, PLASTE^C reports are now sold through the cooperation of the National Technical Information Service (NTIS), 5285 Port Royal Road, Springfield, Virginia 22151.

These innovations in our previously charge-free system are in line with a Department of Defense policy affecting all technical information centers.

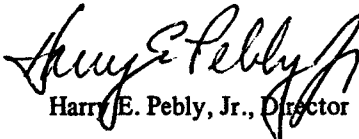
Harry E. Pebly, Jr., Director

PLASTEC REPORT R42

SOLID-PHASE FORMING (COLD FORMING) OF PLASTICS

by

JOAN B. TITUS

JANUARY 1972

**Approved for Public Release; Distribution Unlimited
Available from NTIS at \$10.00**

**PLASTICS TECHNICAL EVALUATION CENTER
Picatinny Arsenal, Dover, New Jersey 07801**

SPONSOR

This report was prepared by the Plastics Technical Evaluation Center under the sponsorship of the Manufacturing Methods and Technology Program, U. S. Army Production Equipment Agency (PEQUA), Rock Island.

As one of its functions, PEQUA sponsors publications to inform the Army Materiel Command (and other Department of Defense activities) of newer processes or technologies. Such publications can be of sufficient potential to warrant detailed evaluations in attempts to attain realistic material, manufacturing and end-item improvements.

The purpose of this report is to provide processing people with the latest available information on new plastics' fabrication techniques of Army interest.

ACKNOWLEDGMENT

The author gratefully acknowledges the assistance of Mr. Allen Shibley in the preparation of this report.

ABSTRACT

This report covers solid-phase forming of plastic parts. These forming concepts involve the use of traditional metal working techniques which are new to the field of thermoplastic part production. Discussed are: the various solid-phase forming processes; thermoplastic materials suitable to these methods; part design; advantages and disadvantages of the processes; equipment and tooling requirements; processing effects on part properties; production economics and suggested applications suitable to these techniques.

DISCLAIMER

Information shown in this report is available from literature sources considered open. The author, sponsoring agency, and PLASTECH do not guarantee the reproducibility nor absolute reliability of the information provided.

The citation in this report of the trade names of commercially available equipment or products does not constitute official endorsement or approval of the use of such products. Reference to a specific equipment or product does not imply that it is the only equipment or product that will be satisfactory for the intended application.

TABLE OF CONTENTS

	Page
SPONSOR	ii
ABSTRACT	iii
INTRODUCTION	1
SUMMARY	3
MATERIALS FOR SOLID-PHASE FORMING	4
SOLID-PHASE FORMING TECHNIQUES	6
Forging	6
Closed Die Forming	6
Cold Heading	10
Extrusion	10
Sheet Forming	12
Stamping	12
Rubber Pad Forming	17
Diaphragm Forming	18
Coining	25
Brake Press Bending	26
Roll Forming	26
Explosive Forming	27
Spinning	27
Drawing	29
EXPERIMENTAL INVESTIGATIONS OF SOLID-PHASE FORMING	44
EFFECT OF SOLID-PHASE FORMING ON PROPERTIES	64
EQUIPMENT REQUIREMENTS	79
ADVANTAGES AND DISADVANTAGES OF SOLID-PHASE FORMING	83
ECONOMICS AND SUGGESTED APPLICATIONS	86
REFERENCES AND AUTHORIZATION	92
BIBLIOGRAPHY	94

INTRODUCTION

The conventional way to form thermoplastics into useful objects is by shaping viscous molten polymer under pressure in a cold mold. Such processes have inhibited the utilization of plastic parts to some extent due to high production costs, expensive and time consuming mold manufacturing, slow production rates due to the cooling steps, inability to meet some part design requirements such as heavy sections and limited use of ultra high molecular weight, high density materials due to processing difficulties.

During the past few years, much effort has been devoted to the use of well-established metalworking techniques as a method of converting thermoplastic materials into finished parts. Two different terms have been used to describe these metalworking techniques: cold forming and solid-phase forming. The cold forming process is performed at room temperature with unheated materials and tooling. In solid-phase forming the material is heated below its melt temperature and formed while in a heated solid state. In some cases the terms are used interchangeably.

This report although entitled "Solid-Phase Forming" will cover both cold and solid-phase forming processes used to produce plastic parts. These methods have been divided into three groups - forging which is chiefly a closed die operation utilizing billets or sheets, sheet forming, and the drawing and deep drawing operations.

An essential requirement for any of these processes is to have the thermoplastic material in sheet or billet form. There are several ways to attain the material for forming such as extrusion, compression molding or casting. Of these, extrusion is most frequently used. The molding compound can be extruded into sheets or rods which are suitable for blanking. In some cases, depending on the type of material, it may be necessary to compression mold or cast the sheet or billets.

The processor may purchase the sheets or billets, or as is normally the case, the preparation of material from a molding compound is an integral part of the processing. In this report, emphasis is placed on the forming operation without going into the details of material preparation for forming. It should be made clear, however, that any evaluation of solid-phase forming techniques, both from the production and the cost viewpoints must take into account the overall integrated process. A suggested integrated system for forging is shown schematically in Figure 1.

In addition to the various processing techniques, the report will include a comparison of materials suitable to these methods; part design; advantages and disadvantages of the processes; equipment and tooling requirements; processing effects on part properties; production economics and suggested applications suitable to these techniques.

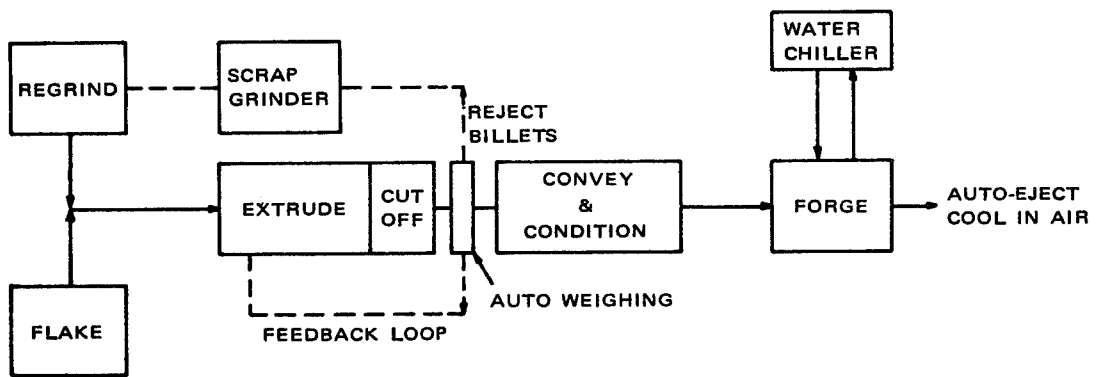

Figure 1. Integrated forging system (1)

SUMMARY

It has been established that ductile thermoplastic polymers can be fabricated by fast metalworking techniques. Such techniques can be classified into three types: forging, sheet forming and drawing. Forging includes closed die forging, open die forging, extrusion and cold heading. Sheet forming includes the related processes such as stamping, rubber pad or diaphragm forming, coining, brake press bending, rolling, spinning, and explosive forming. Drawing may be broken down into shallow or deep drawing. Of these, closed die forming, stamping, rubber pad forming, diaphragm forming, coining and drawing appear to have significant commercial potential.

Materials which have been successfully solid-phased formed include acrylonitrile-butadiene-styrene (ABS), ABS/polycarbonate, cellulose acetate butyrate, polypropylene, and high molecular weight-high density polyethylene. Generally for a sheet material to be solid-phase formable it must have sufficient ductility and strength so that necking does not occur under tensile loads.

Although it is possible to solid-phase form at room temperature, preheating the material to approximately 10° - 20° F below its melt temperature and below its glass transition temperature is recommended. This practice provides optimum part properties and dimensional stability.

Cold working of sheet materials prior to forming and the forming process itself, which occurs below the glass transition temperature, result in material orientation with resultant improvement in stiffness and strength.

Solid-phase forming processes such as forging have opened up new areas to the designers: namely, the use of ultra-high molecular weight, high density plastics and heavy section designs. These areas have been severely limited in the past due to difficulties in molding, large mold shrinkage, and high percent of voids. Utilization of these materials and designs will permit fabrication of parts with high rigidity, high strength, extremely good wear, good abrasion resistance and higher impact strength.

Solid-phase forming processes, for the most part, can utilize metalworking equipment with minor modifications. Their inexpensive tooling, high production rates, ease and economy in preprinting and decoration make them attractive techniques for many applications. Other advantages are fabricated parts without flash, trim or weld lines. The principal disadvantage of these processes is that the advantages must economically outweigh the cost of preparing the billets or sheets, and a somewhat reduced service temperature to prevent springback or excessive recovery of strains imposed during forming.

MATERIALS FOR SOLID-PHASE FORMING

Metal forming processes have been successfully employed with a wide variety of thermoplastic materials including some glass reinforced materials. To be successful, the polymeric materials must possess sufficient ductility to deform to the required shape at the forming temperature. The flow of the material under forming pressure must be such that local necking or cracking does not occur. At the same time the recovery, or "memory", characteristics must be low so that springback and recovery of time dependent strains are minimized. Springback as used in forming technology refers to the recoverable deformations attained after a part is removed from the forming die and which occur within a relatively short period. Thus, polymers such as polycarbonates, polypropylene, cellulose, acetal copolymers, polyphenylene oxides, polysulfones and rubber modified polymers (acrylonitrile-butadiene-styrene, polyvinyl chloride, styrene-acrylonitrile (SAN), etc.) and some glass reinforced formulations can be easily formed while brittle materials such as polystyrenes and the acrylics can not. On the other hand, soft rubbery polymers such as polyethylene can be formed, but the recoverable deformation is very large resulting in excessive springback. To overcome this defect would require long forming cycles and an impractical tool design.

In some cases high molecular weight version of polymers may be readily formed which previously have been formed with difficulty or not at all. Of specific interest is the high molecular weight high density polyethylene (HDPE). This material which can be manufactured in feasible commercial processes has improved properties compared to normal HDPE but is difficult to fabricate into finished parts because of its high melt viscosity. The high melt strength of this polymer becomes an asset in solid-phase forming and parts can be made with good shape retention.

Although certain thermosetting material can be punched or postformed following cure or partial cure, they are too brittle to be processed by the methods mentioned here.

Table 1 lists candidate materials which have been solid-phased formed and the general type of forming which has been successful with each. The table is intended to serve only as a guide as to materials reported in the literature and does not preclude the use of other materials or methods.

Table 1. Materials - Solid Phase Forming

Material	Forging	Drawing	Sheet Forming
ABS	X	X	X
ABS/Polycarbonate		X	
Acetal	X	X	X
Acetal Copolymer	X		
Acrylic/PVC			X
Cellulose Acetate		X	X
Cellulose Acetate Butyrate		X	
Chlorotrifluorethylene			X
Polyamide	X	X	X
Polycarbonate	X	X	X
High Density Polyethylene	X	X	X
High Molecular Weight HDPE	X		X
Polyphenylene Oxide		X	X
Polypropylene	X	X	X
Glass Reinforced Polypropylene			X
Polysulfone		X	X
Glass Reinforced Polysulfone	X		
PVC (rigid)			X
PVC (high impact)		X	X
PVC (chlorinated)		X	
Glass Reinforced SAN			X

With the present interest in solid-phase forming some material suppliers are now offering specific grades for these techniques. The following is a list of such known materials:

Material	Trade Name	Company
ABS	Cycopac 155	Marbon Chemical Co.
ABS	Cycolac MS	Marbon Chemical Co.
ABS/Polycarbonate	Cycolac 800	Marbon Chemical Co.
40% Glass Reinf. Polypropylene	Azdel P-100 Series	GRTL Co.
40% Glass Reinf. SAN	Azdel A-200 Series	GRTL Co.

The exact formulations of the above materials which make them suitable for solid-phase forming are not known. Presumably through the use of lubricants, in-situ copolymerization, and selection of the diene, an ABS compound can be optimized for forming operations. The addition of fiberglass reinforcement to the Azdel compounds can be expected to affect the strength, modulus, yield, elongation and heat distortion temperature of the polymers and thus affect its forming characteristics.

It can be anticipated that additional materials will be developed which will take better advantage of the various processes and will impart superior properties to the finished parts. This will result in the greater utilization of plastics for structural, impact, and wear applications. Such developments may be brought about by use of fillers, blends of molecular fractions of the polymers, and blending of polymers. Recent developments in co-extrusion are expected to provide an additional impetus to the acceptance of these forming techniques.

Most preliminary screenings of materials suitable for solid-phase forming are based on uniaxial tension and compression data such as ultimate strengths, yield strengths and elongations. However, specific tests have been developed for this purpose. One method recommended by the Marbon Chemical Company is termed the Bubble Test. In this test a sample sheet is clamped in a fixture at ambient temperature and air is applied to form a bubble. The bubble's height and the pressure it withstands before failure indicate its formability. Also, the type of failure is important. A brittle material fractures while pinholes develop in ductile materials. For example, satisfactory 0.015 inch thick ABS material develops a bubble one inch high and withstands 40 psi before pinholing, an 0.018 inch thick material blows at 45 psi and a 0.012 inch at 30 psi (24).

A second method is a modification of the Swift Cup Test. Here fully constrained blanks are drawn at conventional speeds and at high loading rates to determine maximum drawing rates and limiting draw ratios.

SOLID-PHASE FORMING TECHNIQUES

FORGING

There has been considerable developmental work on the adaptation of metalworking forging methods to plastic sheets and billets. They include open die, typically used in drop forging; closed die or press forging; cold heading; and high energy rate forging (50-200 ft/sec.)

All methods have been tried with acceptable parts being produced. However, of all of these methods, the closed die and cold heading techniques have shown the most promise. Open die forging does not produce a finished part so it does not compete economically with other fabricating methods. High-energy rate forging is a relatively expensive method with no obvious advantages over the closed-die forging. Consequently, it is not normally considered.

Closed Die Forming

DESCRIPTION OF PROCESS

This type of forging is illustrated in its simplest form in Figure 2. Two opposing shaped punches mate in a common floating ring to form a closed die. With the upper punch raised, a preheated billet of specific weight and shape is placed on the lower punch in the die ring. The upper punch closes and pressure is then applied, forming the billet to the desired shape. After a short dwell time the upper punch is raised, the die ring is pulled down over the lower punch, and the lower punch is raised to eject the forging.

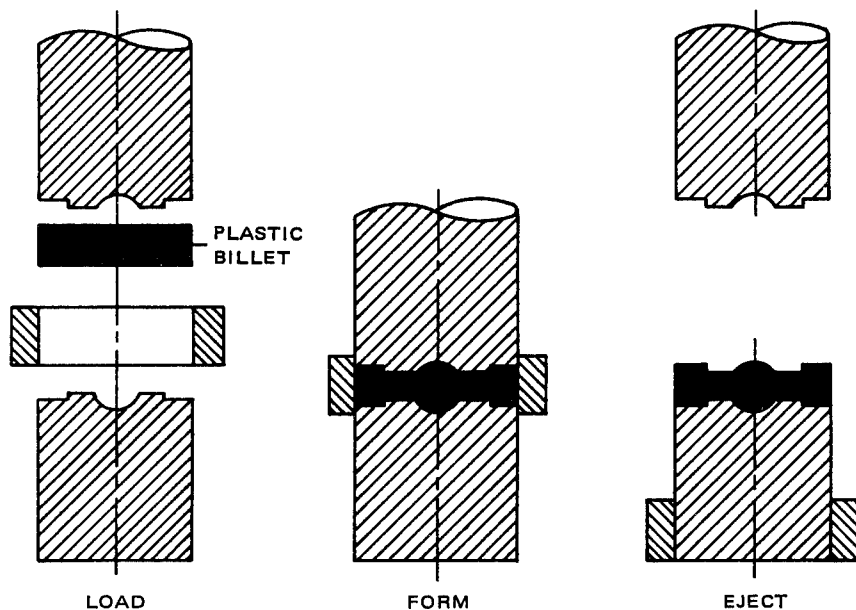

Figure 2. Forging process (2)

PROCEDURE AND TOOLING

Like all other methods of converting thermoplastic resins, the forging process offers many variations in each step depending on the resin selected and the part requirements. The following are indications of typical parameters in closed-die forging which have produced satisfactory items.

Temperature - Thermoplastics can be cold forged, but fairly high pressures are required (10-15 tons/square inch cold versus 3-5 tons/square inch at higher temperatures); there is considerable springback or recovery, and poor part filling during forming. Also, excessive material movement results in fracture of the finished part. In addition, preheating the billet improves the dimensional stability of the formed part. For example, a room temperature formed part may be adequate for use at 150°F but not at 200°F. With optimum preheat, polypropylene forged water pump rotors have been reported to withstand 24 hours at 250°F without exceeding a 0.5 percent dimensional change (3).

Optimum billet temperature is at or near the crystalline melting temperature of the plastic. For high density, high molecular weight polyethylene it is about 250-265°F; and 300-320°F for polypropylene. Rigid, non-crystalline polymers (polysulfones) and polyphenylene oxides require billet temperatures above the second-order transition or a temperature at which the tensile strength has been reduced to 300 psi (1).

A constant temperature throughout the billet must be maintained. Temperature variations can give rise to residual stresses and differential recovery or springback. Also, a fairly long soak time at the forging temperature is necessary because of the low thermal conductivity of plastics. Some examples are: a 2 1/2 inch polypropylene sabot block billet was heat soaked two hours at 320°F and 0.78 to 1.18 inch thick polypropylene wheel billets for one hour at 320 to 329°F before forging (4, 5).

Mold temperature is significant but less so than billet temperature. Optimum results were obtained at 40° to 80°F for high density high molecular weight polyethylene (1). Difficulty is experienced in filling molds with cold tools because of the rapid surface chilling of the plastic.

Forming Cycle - Since the billet remains in the solid state, no solidification time is required. It is necessary, however, to maintain a forging pressure for a period of time after the initial displacement of material. This is to permit the stress relaxation required to prevent recovery due to the plastic's "memory" effect. The forming cycle - dwell time, forging pressures and speed - will vary with part design, material used and the material's temperature.

A 3/8 inch thick polypropylene pump rotor had an overall cycle time of 20 seconds, a dwell time of 10-15 seconds, and a pressure of 3-5 tons (3). On the other hand a 1 1/2 inch thick polypropylene sabot required a dwell time of 3 minutes and a 100-ton pressure (4).

Some general observations concerning forging cycles can be made:

- Higher forging pressure reduces cycle time. A full 100-ton pressure permitted dwell time of three seconds for high molecular weight polyethylene. At 10 tons, the same material required 11 seconds (1).

- The required forging tonnage increases rapidly as the thickness decreases. Thicknesses of 0.10 inches are considered the lower limit for forging polypropylene. Minimum cross sectional thicknesses obtainable with high density polyethylene are in the order of .040 inches. However, with the addition of flow promoters thinner parts 0.02-0.025 can be attained (1).

- Metal inserts can be forged in place without affecting the time cycle.

Tooling - The material reportedly used for most tooling has been a machinable grade of heat treated tool steel having a hardness of 34-42 on the Rockwell C scale. Since there is no metal-to-metal tool closure, close tolerances or sophisticated cooling, tooling costs are estimated to be about one-third of its counterpart for injection molding.

PART DESIGN AND QUALITY

Part finish is good provided the billet surface is good quality. There is no difficulty with conformance to mold details, textured surfaces or application of lettering or metal inserts.

Mold shrinkage for forged high density polyethylene was less than one quarter that of injection molded parts (0.006 in/in. versus 0.025-0.028 in/in.). Parts with low initial warpage showed no tendency to warp further upon standing or after thermal aging 21 days at 176^oF followed by 14 days at 200^oF. In fact, no warpage or crazing occurred after immersion in water or ethylene glycol after 14 days at 212^oF. However, items fabricated at too short cycle times did warp upon removal from the press and warped further upon standing or heating (1).

Forging is not limited to simple, circular, symmetrical shapes. With split tools, it is possible to fabricate undercuts in parts or by means of "cored forging" to form hollow structures.

A "cored forging" valve body is shown in Figure 3. The feed is a solid rod billet which is forced to extrude at right angles to the pressure forming a cross. The arms of the cross are forced over side punch core pins which produce the hollow structure.

Another variation in forging is the pipe coupling shown in Figure 4. In this example, a heavy walled tube is formed into a thinner walled pipe coupling. The inside diameter of the original tube becomes the shoulder of the coupling and the original outside diameter is maintained throughout.

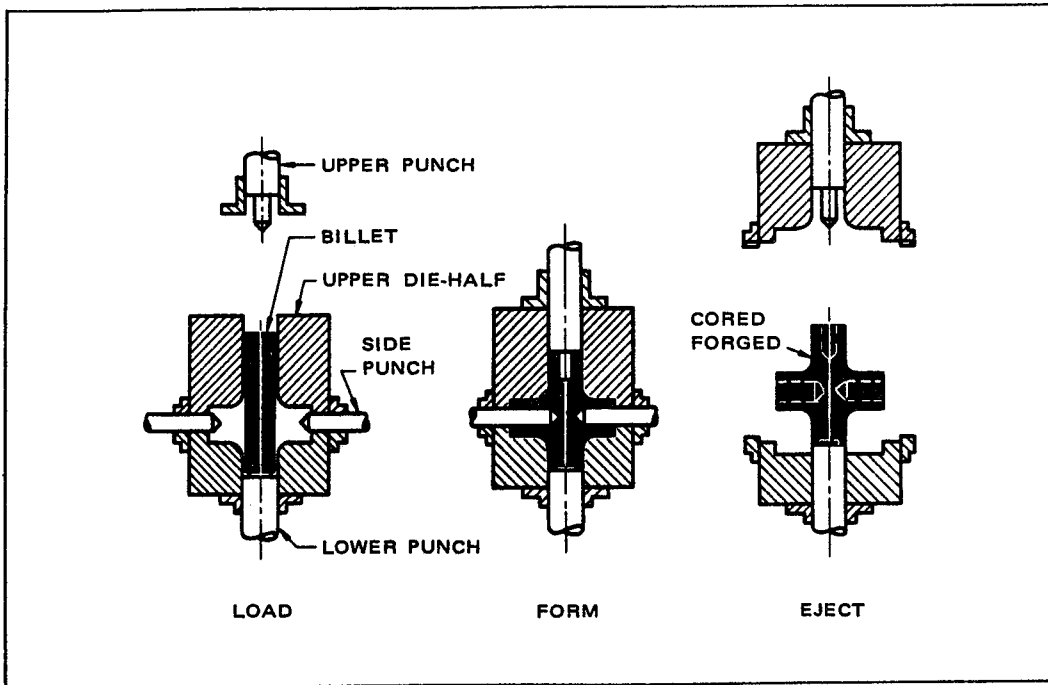

Figure 3. Cored-forged valve body (3)

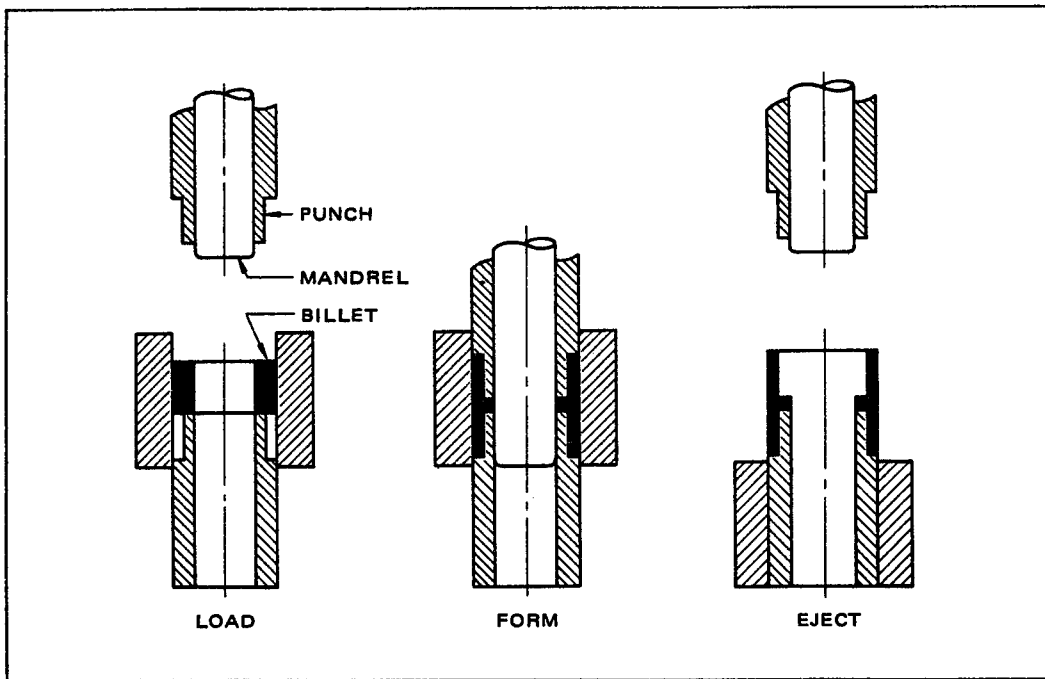

Figure 4. Forging pipe coupling (3)

Cold Heading

This high speed forming technique is used for shaping such parts as rivets, bolts, screws, knobs and similar objects.

DESCRIPTION OF PROCESS

The operation is typically carried out in a series of steps starting with a continuous rod or bar feed stock. The feed stock is first cut to the required length, rough formed in one cavity, and finished formed in a second cavity. The process is readily automated and is favorable for high volume production.

Test runs on 1/8 inch and 1/4 inch diameter polypropylene rivets are reported in Reference 2. Results show that polypropylene can be cold headed on metal tools without modification of the equipment.

Extrusion

Of all of the solid-phase forming techniques extrusion, both forward and backward, has met with the least success both technically and economically.

DESCRIPTION OF PROCESS

Impact or Backward Extrusion - In this process a warm billet is placed in a die and extruded between the punch and die under very high pressures - 20 to 30 tsi for 30 mil walls and 5 tsi for 125 to 200 mil thick walls. (See Figure 5)

Tool shifting was a severe problem at the lower pressures and uncontrollable at the higher pressures. Also, when parts were impact extruded to heights of more than one diameter there was difficulty in obtaining good circumferential distribution. There was a strong tendency for tearing on the bottom inside surfaces (3).

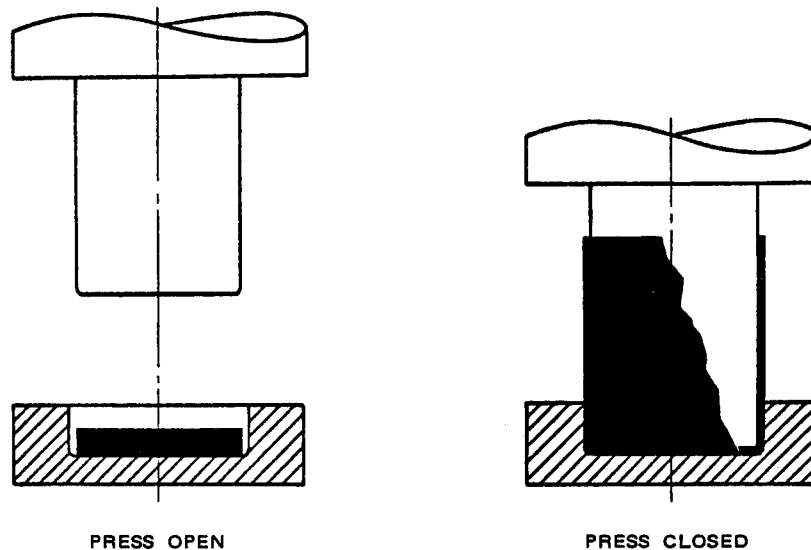

Figure 5. Impact extrusion (2)

Forward Extrusion - This process requires a heated preform with a heavy side wall and bottom in the final dimensions desired. Two concentric punches are used. The inner punch is a mandrel which sets the die gap. It is pressured slightly by shop air (about 100 psi) against the part bottom. The outer punch extrudes the preform wall under about 5 tsi pressure. Any material not extruded becomes the flange on the open end of the part as shown in Figure 6.

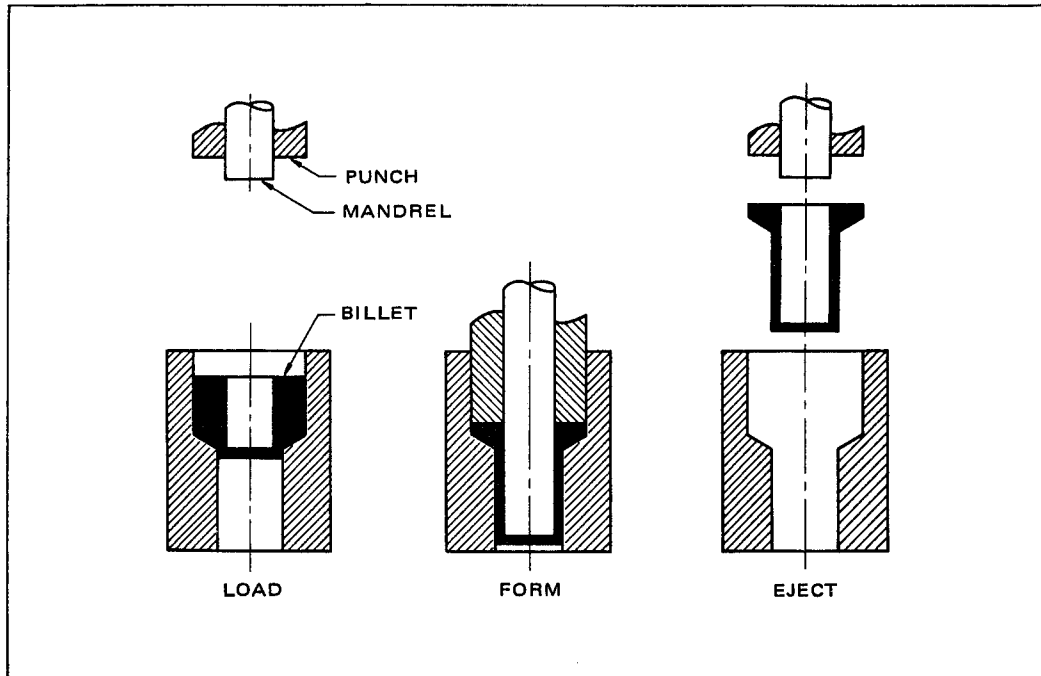

Figure 6. Forward extrusion (2)

Excellent parts varying from 2 to 10 inches have been fabricated by this method. However, because of the problems and economics of preparing the preforms, the potential of this technique is limited. Also, most parts and materials suitable to this technique can be produced by more promising methods such as closed die forging and deep drawing.

In some respects, extrusion can be considered a modification of the closed die forging process. For example, the valve body and pipe coupling shown in Figures 3 and 4 are combinations of forging and extruding.

SHEET FORMING

In addition to the closed die forging processes for sheet stock or billets, the sheet material may be stamped, diaphragm formed, high-energy rate formed, brake pressed, coined, or roll formed. These methods have the advantages of:

- reduced capital equipment requirements,
- minimized preheating cycles,
- increased production rates,
- easier control of material orientation to obtain improved properties.

Stamping

DESCRIPTION OF PROCESS

Stamping employs a rapid application of force and is limited to shallow depth, normally 1/4 inch or less. Mechanical presses are usually used in this process. (See Figure 7)

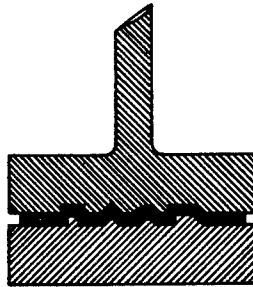

Figure 7. Stamping tool using matched steel members (6)

PROCEDURE AND TOOLING

Stamping of thermoplastics is somewhat similar to the drawing process, the major differences being in the tooling and the rapid application of pressure.

Glass fiber reinforced thermoplastic sheet can also be stamped successfully. In fact, the GRTL Company was formed to supply the automobile industry with glass reinforced polypropylene and styrene

acrylonitrile stamped components. The solid-phase forming procedure for this type material is more critical than the nonreinforced sheet and therefore is described here.

The reinforced sheet is sheared or die cut into blanks somewhat smaller and thicker than the desired part. The blanks are then heated on a wire or screen carrier to 400°F in an infrared oven. Although this temperature is above the melting point of the resin (not normally done in solid-phase forming), it has the consistency of wet cardboard due to the glass reinforcement. The hot sheet is then fed to the press and stamped between cooled matched metal dies (7).

Forming Cycle - A 6 to 15 seconds dwell time is customary in the 10 to 20 seconds forming cycle to permit cooling and solidification of the resin. The dwell time depends upon part thickness and is adjusted to the part design so that it will not distort upon removal from the die. Cooling is achieved by stopping the press at the bottom of its stroke in water cooled dies.

Stopping the press at the bottom dead center (bdc) of the stroke represents the major difference between metal and plastics stamping. Unlike metal stamping, stopping the press at the bdc does not pose any problems. In fact, a Niagara 45 ton press running at 35 strokes per minute has been reportedly stopped about a million times on bdc while forming plastics and the original clutch facing and brake linings were still in good operating condition (8). The reason for this is that the forming of the plastic rather than the brake absorbs most of the energy in stopping the press.

In stopping at the bdc of the stroke, the brake clamps into the declutched press ram at the last moment when the press motion is nearly zero. Mechanical presses have a sinusoidal motion since it is a crank or eccentrically driven device. Near bdc it contacts the hot plastic which, due to swelling, has an increased volume. As the sinusoidal speed curve decreases the area of plastic, which is being formed and compressed, increases. The plastic becomes a very effective shock absorber. Just as the press reaches bdc, the clutch disengages the flywheel, and then the brake engages and holds the press ram stationary in this position. Also, since the forming dies are kept within fractions of a percent constant in two dimensions (width and length), all volumetric change occurs in the thickness direction. A 40 percent to 50 percent or more reduction of thickness can take place in stamping. This decays a large amount of the forming pressure and the press ram which followed the plastic as it shrunk sits on top of the part with little pressure. As a result, when the press is opened the clutch needs very little torque to overcome the residual strain, and no significant wear on the clutch facing occurs.

It is not necessary to stop the press at the same place every time. Two or three degrees deviation before or after the bdc can be tolerated. For example, on a 14 inch stroke press, 3 degrees are equivalent to a distance travel of nearly 3/8 or 0.366 inches on the end of the crank but only 0.009597 inches in height. Most presses can be stopped to within 1/4 inch or 0.001 inches in height (8).

Short Flow Forming - In short flow forming (see Figure 8) the hot blank is always smaller than the size of the part to be produced. It is recommended that the blank be about 1/4 to 3/8 inches shorter all around since the blank will flow this distance without significant glass/resin separation (8). With a telescoping edged die a flash and trim free part is produced. Short flow forming produces a part that has about the same properties as the starting sheet. Very little glass orientation takes place, which is normally a desirable feature.

Short flow can be used for in-mold lamination of overlays since it will introduce very little distortion of the overlay. It should also be used to produce thin parts from thin sheet. A reasonably accurate loading mechanism is needed to place the hot blank in the die. Clamps that would shield part of the blank from the heating source cannot be employed. The blank must be uniformly heated and adequately supported.

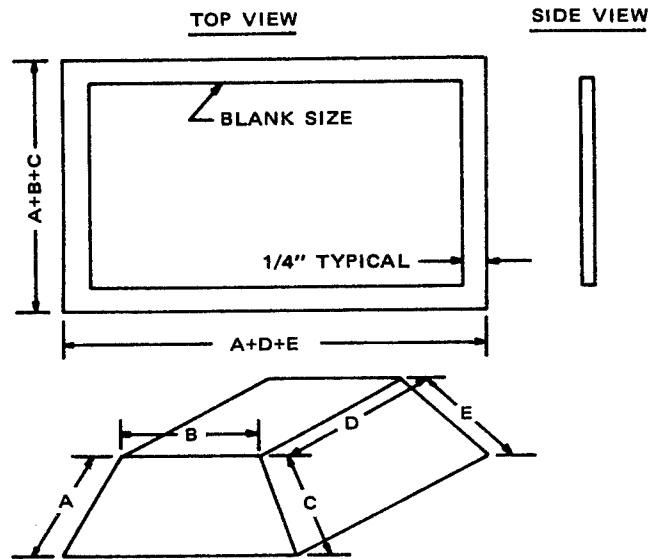

Figure 8. Short flow forming (8)

Center Flow Forming - Center flow forming, shown in Figure 9 is used to produce parts with varying cross sections and those with larger part thickness tolerances. It is a versatile method and can be used alone or as a “hybrid” with the short flow method. It consists of two rolling banks of sheet which propagate in opposing directions. These banks produce the following effects: sweep the air out of the die to eliminate air entrapment; permit thicker sections through the addition of material to the basic sheet; subject the resin to shear, thus lowering viscosity and aiding in wetting the glass fibers; and wet the die surfaces which produces good surface finish (8).

The effect of center flow can be obtained by adding a narrow strip to the center of the blank or cutting the blank in two and locating it in an overlapping configuration. The additional strip can be put on the blank prior to heating or it can be heated separately.

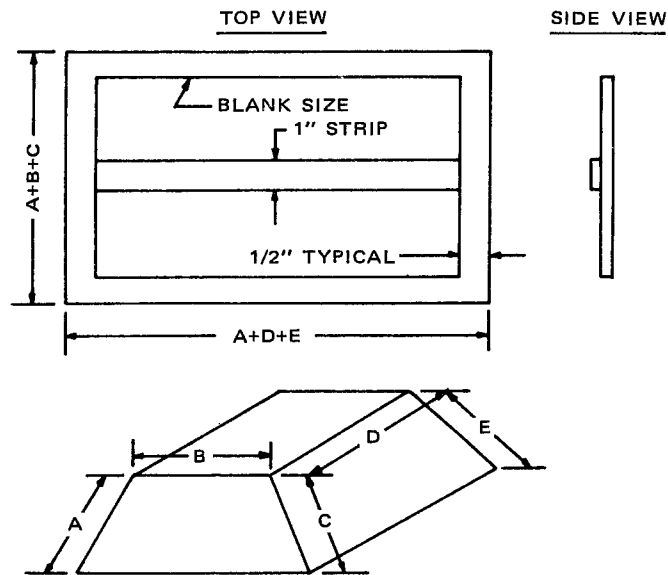

Figure 9. Center flow forming (8)

Tooling - Stamping a glass reinforced thermoplastic sheet requires an oven to heat the blank, a matched-metal die for shape and a mechanical stamping press for forming force. In production runs an automatic feeding mechanism that transfers the cold sheet into the oven and to the die after heating, as well as a discharge apparatus for the finished part, is necessary.

An infrared oven with a fast rise, fast decay source is desirable. The best heat source for both glass reinforced SAN and polypropylene was a high density tungsten/quartz unit (25 kw/ft^2). This oven decays within 1 to 2 seconds. A low density tungsten/quartz (4.5 kw/ft^2) oven is the next best source. Both types of ovens sandwich the cold blank in the focal point of opposing heater banks (8).

Hot blanks can be conveyed while supported on a wire grid as shown in Figure 10. It can also be moved by mechanical clamping with hot clamps made from materials with a low heat absorption coefficient. Vacuum systems using a glass, wooden or a metal tube with low heat absorbing ends, (i.e. phenolics) can be lowered onto the hot sheets. A conservative suction cup/sheet ratio of 1:150 (1 in.² cup supports 150 in.² of 0.100 in. thick sheet) has been used successfully for moving sheets (8).

Matched metal dies with telescoping shear edges are made from conventional tool sheet (see Figure 11). Water cooling channels are recommended in production runs. Externally piped, straight through, back and forth design is adequate. No intricate machining is required. Normally, plant water will provide adequate cooling.

Prototype dies can be built of aluminum, kirksite or epoxy although they will not produce parts with finished edges. Prototype parts can also be produced by modifying compression molding tools. Even metal stamping dies can be modified to produce prototypes.

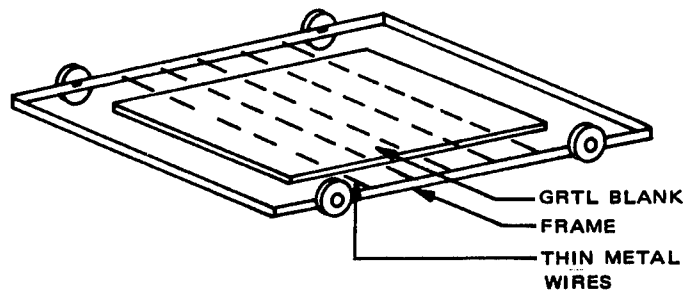

Figure 10. Wire grid support (8)

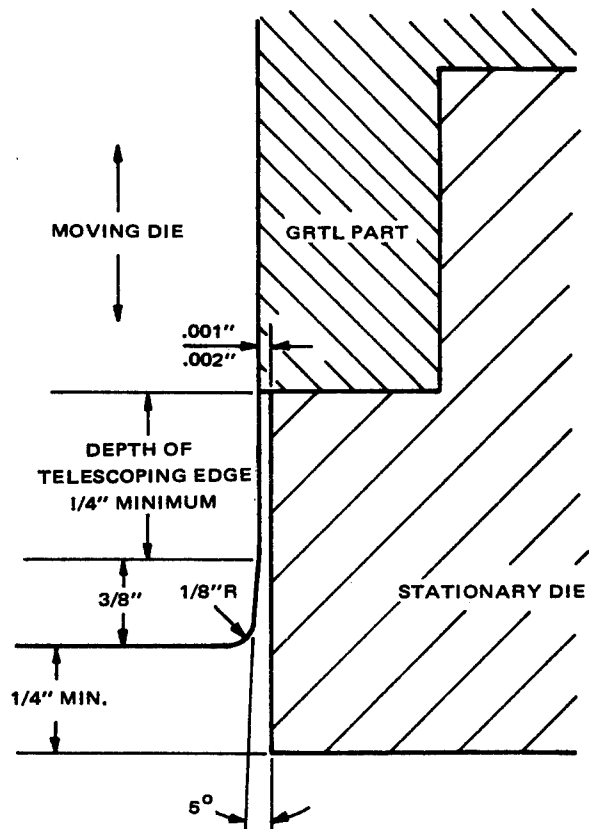

Figure 11. Design of telescoping edges (8)

PART DESIGN AND QUALITY

Bosses or thick ribs can be produced in three ways: by flowing the hot blank; adding a swatch to the blank; and by adding a cold part into the die. The last two methods add little or no time to the forming cycle. The first technique lends itself to shallow bosses and ribs. Metal bolts, rivets, etc. can be added by inserting them in the die.

Overlays of thermoplastics, metal foils, fabrics, and foams can be placed in the die, onto the preheated blank, or into the die area on a frame. The overlay can be embossed, printed or pigmented. The embossing will largely be retained or, if desired, they can be embossed by the use of suitably textured dies. Depending on the matrix resin system of the sheet and the type of overlay selected, they can be chemically bonded (with or without adhesives of suitable primer) or mechanically interlocked during stamping.

Generally the more flow introduced during forming the better the surface quality; however, more glass fiber orientation results (8).

Rubber Pad Forming

DESCRIPTION OF PROCESS

This process is similar to matched-metal stamping except one of the metal dies is replaced by a block of solid rubber. A heated blank is placed on the rubber block in the lower die and the upper die, containing the mold, presses the blank into the rubber. The rubber is compressed, wiping the sheet into the mold intricacies as shown in Figure 12. Material cannot be flowed to the extent that it can with matched metal die stamping. However, more uniform pressure is exerted on the blank.

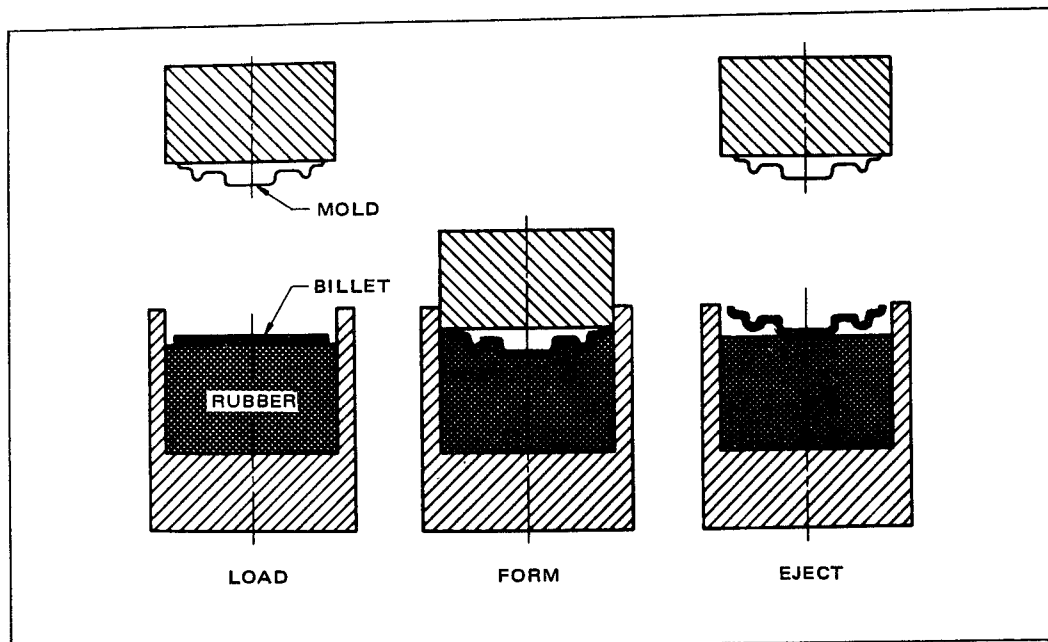

Figure 12. Rubber pad forming (3)

PROCEDURE AND TOOLING

Forming Cycle - A variety of nonreinforced thermoplastics sheets 0.040 to 1.0 inch thick have been rubber pad formed. The sheet material is heated to below the melting point as in deep drawing.

A typical production cycle requires about 20 seconds with a 10 second dwell time to permit stress relaxation. Good dimensional stability has been reported since less springback is experienced with this method than with the matched-metal stamping. Forming pressures on the rubber pad are on the order of 1000-1500 psi. Forming speeds are normally less than those in matched-metal stamping (3).

Tooling - Tooling requirements for rubber pad forming are: an air circulation oven for heating the sheet, automatic transfer feeding and discharge equipment (optional), a hydraulic or mechanical press, set of dies, rubber pad and male or female mold.

Rubber pads can be vulcanized rubber or urethane of about 60 durometer hardness. They should be at least three times as thick as the draw depth. The maximum practical draw is considered to be about two to three inches. Production molds are usually made from steel or cast aluminum (3).

Diaphragm Forming

In diaphragm forming, the rubber pad of the previous process is replaced by a fluid pressurized diaphragm which exerts pressure on the sheet stock. Forming may be adapted to shallow draws as in stamping or to deeper drawn items. The process involves cheaper tooling cost, relatively high-priced machinery and moderate pressures. It is advantageous for forming complex parts or large parts requiring only one finished side. Two of the most common variations in the process are discussed below.

DESCRIPTION OF PROCESS

In one case a controlled fluid pressure forming chamber, rubber diaphragm, plastic blank, drawing or drawpad and punch are arranged as shown in Figure 13. The blank is loaded onto the drawing; the forming chamber is lowered and the punch advanced into the plastic sheet. After the press has closed, before the punch has moved, a precharge pressure is applied to the forming chamber by pumping in hydraulic oil behind the diaphragm. The punch is then driven into the chamber at a preset depth. The chamber is decompressed, the press opened and the punch withdrawn almost simultaneously.

A second variation is shown in Figure 14. A pressure bag is suspended from the upper press platen and confined with a die ring. The press itself acts as the pump as well as the press. The lower platen contains the punch which mates with the die ring. The heated blank is loaded onto the punch, the press closes making the water bag hydrostatic which forces the sheet into the mold.

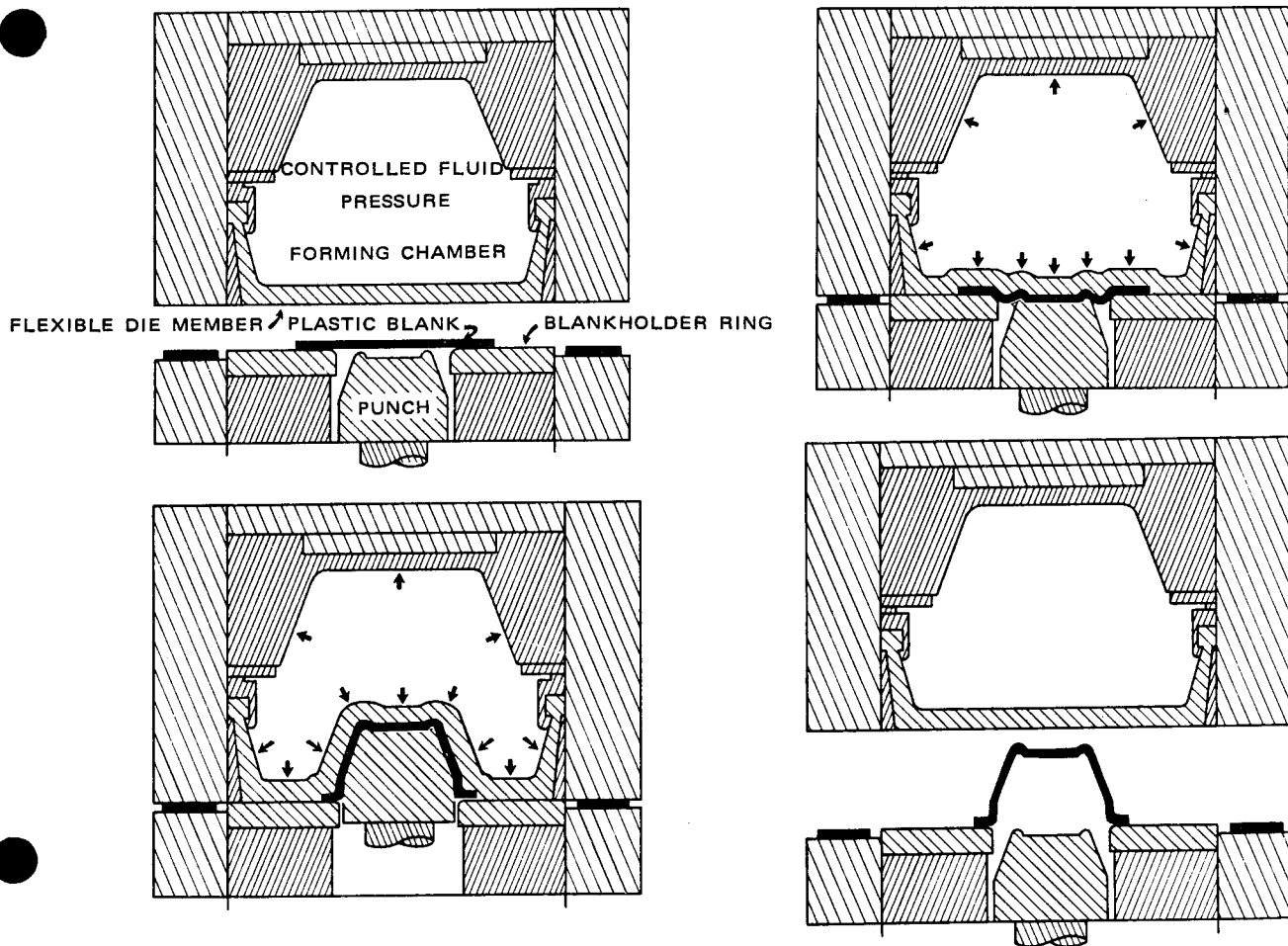

Figure 13. Fluid forming (9)

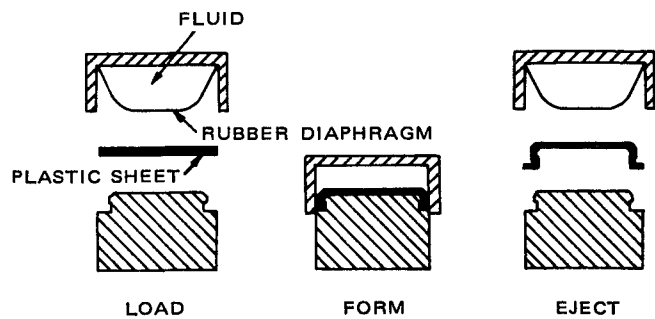

Figure 14. Hydrostatic forming (10)

PROCEDURE AND TOOLING

Temperature and Lubricants - As in deep drawing, the sheet material must be uniformly preheated to 15 to 20 degrees below its melt temperature and lubricated prior to forming. Failure to lubricate the material will result in stopping the flow of material and piercing the blank with the punch.

Forming Cycle - After heating, the sheet is formed in a hydraulic or mechanical press or hydroform machine under pressure for a 10 to 15 second dwell time to permit stress relaxation. A typical forming cycle is 15 to 20 seconds. The pressure varies from 100 to 500 psi depending on part configurations.

During hydrostatic forming, the rise in the forming chamber pressure with punch penetration, with small items, can be so moderate that it is necessary to pump additional fluid into the chamber to develop the desired ultimate forming pressure. Conversely, the volume and punch penetration in the hydrostatic forming mode may produce excess forming pressures. In such cases, a hydraulic relief valve is used to bleed fluid out of the forming chamber and thus limit the forming pressures to lower values than would normally develop.

It is also possible, by means of valving to use various combinations of forming pressures. Pressures may be allowed to build naturally to a predetermined value after the first half of the punch stroke and then be increased by pumping to a larger value on the last quarter of the punch stroke.

Diaphragm forming differs from the other solid-phase forming methods. In those methods, the blank is subjected to only the stresses developed from the deformation of the blank, except at the end of the stroke when the full compressive pressure of the press is applied. In diaphragm forming, compressive pressures are continually applied in addition to the deformation stresses.

Tooling - Diaphragm forming requires a press or hydroforming machine, a controlled fluid chamber, a rubber diaphragm, drawing, punch and pump (if using fluid forming) in addition to the normal heating, transfer and part discharge equipment.

With a fluid forming machine it is possible to: vary or limit the forming pressure applied to the material independently of the punch penetration by bleeding out or pumping in hydraulic oil to the chamber behind the diaphragm; perform hydrostatic forming by shutting off the escape of oil from the chamber; and/or precharge the fluid chamber by applying various levels of pressure on the material before the punch is advanced into the sheet. This provides the initial blank-holding pressure usually desirable to prevent wrinkling of the part as the blank is drawn in around the entering punch.

PART DESIGN AND QUALITY

Part design and quality depend on the material selected, processing variables, configuration and tooling. In order to determine the significance of each of the first three variables, a study was made on a series of cups prepared on a hydroforming machine from blanks marked with grid patterns. The percent springback and strain as a function of material, blank thickness, forming rate (punch velocity) and precharge pressure were measured at four places (stations 10-14) on the cup as shown in Figure 15 (12).

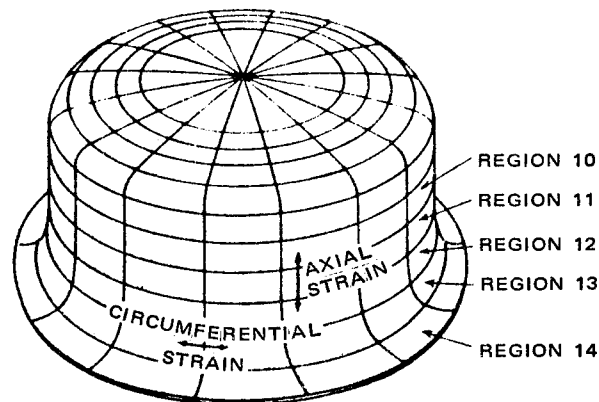

Figure 15. Nomenclature of the grid pattern on a formed cup (12)

The results and basis of the calculations are given in Table 2. From this data the following general conclusions can be made on the three materials studied (12). As the precharge pressure increased from 1000 to 4000 psi:

- Significantly large changes in circumferential compressive strain occur, increasing in region 10 by 10 percent to 20 percent depending on material. This reflects the closeness of the sheet to the punch. It decreased in regions 12-14 from 2 percent to 29 percent depending on position and material. Region 11 changed little, less than 4 percent in both directions.
- Axial tensile strain increased because more tension was required to pull the blank into shape.
- Cups were formed with thinner walls. The cellulosic material thinned out by 100 percent to 400 percent as the precharge pressure was increased. The polycarbonate material thinned up to 37 percent near the bottom of the cup. The ABS materials showed significant increases in thinning - ranging from 15 percent near the open end of the cup to 120 percent in regions closer to the bottom.
- Decreases in circumferential springback were produced in region 10 (38 percent in ABS, 50 percent in polycarbonate and 64 percent for cellulosic) and increases in regions 12, 13, and 14. Region 11 increased or decreased depending on the material.
- Axial springback decreased for cellulose and polycarbonate but increased for ABS.

This experiment indicates that the increase in precharge pressures at the lowest forming rate results in blanks being deformed at a higher pressure for a longer portion of the forming cycle. This would account

Table 2. Conditions and Results of the Cold Forming Experiments^a (12)

Experiment	Material	Thickness mils	Precharge Pressure 10 ⁶ p.s.i.	Punch Velocity in./min.	Springback, %			Strain, %														
					Circumferential ^b	Axial	Thickness ^c	Compressive ^d	10	11	12	13	14	15	16	17	18	19	20			
Thickness	Uvex ^f	60	1	18	3.2	3.6	5.7	11.9	-14.8	-7.8	0	+13.1	-8.7	-17.8	-24.4	-34.2	-25.4	+40.0	+34.6	+50.0	+11.1	
		80	1	18	3.3	3.8	6.2	10.5	-12.3	-7.2	-2.5	+14.8	-8.7	-17.7	-24.0	-35.3	-26.1	+48.0	+38.5	+50.0	+7.4	
		100	1	18	3.0	3.9	6.2	10.6	-15.3	-11.2	-5.1	+15.3	-8.9	-17.6	-24.0	-35.1	-26.1	+48.0	+38.5	+50.0	+7.4	
	Polycarbonate	40	1	18	2.8	3.2	4.0	9.0	-7.5	-5.0	0	+17.5	-9.1	-18.2	-25.6	-28.7	-29.8	+44.0	+34.6	+50.0	+5.9	
		60	1	18	2.8	2.9	3.9	8.7	-9.8	-4.9	+1.6	+18.0	-9.1	-18.4	-25.6	-29.4	-30.6	+34.0	+38.5	+50.0	+18.5	
		90	1	18	2.9	3.6	4.9	8.0	-9.6	-7.5	0	+16.0	-9.0	-17.9	-25.0	-29.4	-30.4	+24.0	+26.9	+33.3	+18.5	
	ABS	60	1	18	2.4	2.9	5.1	7.6	-13.1	-13.1	-8.2	+13.1	-9.4	-18.4	-24.8	-25.5	-28.7	+52.2	+42.3	+54.0	+7.4	
		90	1	18	2.7	3.5	5.7	5.7	-10.1	-10.1	-5.6	+14.6	-9.2	-18.0	-24.4	-24.8	-26.0	+44.0	+38.5	+50.0	+11.1	
		120h	1	18	2.8	3.7	5.7	5.3	-10.1	-9.2	-5.9	+13.4	-9.1	-17.8	-24.3	-25.9	-27.4	+44.0	+34.6	+45.8	+7.4	
	Form Rate	Uvex	60	1	18	3.2	3.6	5.7	11.9	-14.8	-9.8	0	+13.1	-8.7	-17.8	-24.4	-34.2	-25.4	+40.0	+34.6	+50.0	+11.1
			80	1	36	4.4	4.3	5.7	11.3	-8.8	-5.3	+1.8	+5.3	-7.6	-17.3	-24.4	-27.0	-28.0	+44.0	+34.6	+50.0	+45.8
			121	1	78	4.8	4.9	5.4	7.4	-8.6	-6.9	-3.4	0	+15.5	-7.3	-16.9	-24.6	-28.7	+36.0	+30.8	+50.0	+33.3
Polycarbonate		60	1	18	2.8	2.9	3.9	8.7	-9.8	-4.9	+1.6	+9.8	-9.1	-18.4	-25.6	-29.4	-30.6	+34.0	+38.5	+50.0	+18.5	
		60	1	36	3.4	3.6	4.1	5.5	-9.9	-1.7	+3.4	+8.2	-8.3	-17.7	-25.4	-31.0	-31.9	+40.0	+30.8	+50.0	+22.2	
		60	1	78	3.7	3.9	4.3	1.1	-4.9	-1.7	+4.3	+9.7	+20.9	-8.3	-17.5	-25.5	-36.2	+34.3	+40.0	+30.8	+58.3	
ABS		60	1	18	2.4	2.9	3.9	7.6	-13.1	-13.1	-8.2	+13.1	-9.4	-18.4	-24.8	-25.5	-28.3	+52.0	+42.3	+54.2	+7.4	
		60	1	36	3.4	3.8	4.5	7.6	-5.0	-3.0	0	+3.6	+21.4	-8.6	-17.7	-25.3	-28.5	+29.4	+34.6	+41.7	+55.9	
		60	1	78	3.4	3.8	4.3	3.5	-3.3	-3.3	0	+3.6	+21.4	-8.6	-17.7	-25.4	-30.0	+30.6	+46.9	+45.8		
Precharge		Uvex	80	2	18	3.3	3.8	6.2	10.5	-12.3	-7.2	-2.5	+14.8	-8.7	-17.8	-24.4	-35.3	-26.1	+48.0	+38.5	+50.0	+7.4
			80	3	18	3.2	3.3	7.5	10.5	-21.3	-13.8	-12.5	+12.5	-9.6	-18.1	-23.0	-21.0	-23.6	+36.0	+30.8	+50.0	+35.9
			80	4	18	1.5	3.1	8.5	7.9	-24.0	-16.3	-12.5	+11.3	-10.5	-18.4	-23.3	-21.0	-21.2	+36.0	+30.8	+50.0	+33.3
	Polycarbonate	60	2	18	2.8	2.9	3.9	8.7	-9.8	-4.9	+1.6	+9.8	-9.1	-18.4	-25.6	-29.4	-30.6	+34.0	+38.5	+50.0	+18.5	
		60	4	18	1.9	2.1	3.7	5.7	-14.8	-9.8	+1.6	+3.4	+16.4	-9.8	-19.0	-25.8	-26.2	+32.0	+46.2	+54.2	+27.0	
		60	4	18	1.4	2.1	4.8	6.4	-13.1	-6.7	0	+9.9	+18.3	-10.2	-19.1	-25.0	-23.9	+40.0	+33.8	+62.5	+28.0	
	ABS	60	1	18	2.4	2.9	5.1	7.6	-13.1	-13.1	-8.2	+13.1	-9.4	-18.4	-24.8	-25.5	-28.3	+52.0	+42.3	+54.2	+7.4	
		60	2	18	2.3	3.9	7.9	10.3	-20.0	-16.7	-14.4	+7.8	+10.0	-9.5	-17.7	-25.8	-26.3	+72.0	+53.9	+50.0	+7.4	
		60 ^g	3	18	1.5	3.8	10.6	11.3	-27.0	-20.2	-18.0	+9.8	+11.2	-10.3	-17.7	-20.8	-18.2	+80.0	+61.9	+33.3	+11.1	

a—Conditions held constant throughout experiment: percent reduction, 46.5%; blank diameter, 7 in.; lubricant, Cimflo 10 paste (a product of Cincinnati Milling Machine Co.); depth of draw, 2-1/8 in.; initial punch height, 1/8 in.; and all parts were formed using a "natural" forming cycle.

b—Circumferential springback is calculated using the final diameter (Df) measurements (taken when computing the compressive strain) and punch diameter. Dp (which is constant 3.75 in.) and the equation, circumferential springback = (Df - Dp) / Dp, where Df is final thickness of sheet.

c—Thickness strain = (lf - lo) / lo, where lo is initial thickness of the sheet, lf is final thickness of the sheet.

d—Compressive circumferential strain = (Df - Dp) / Dp, where Df is final diameter of a circular line drawn on blank prior to forming. Do is original diameter of line.

e—Axial strain = (lf - lo) / lo, where lf is the final distance between two circumferential lines drawn on a blank prior to forming and lo is the original distance between these lines. (No axial strain values could be computed in region 14 due to the edge condition of the part.)

f—Numbers relate to regions shown in Fig. 1.

g—Cellulose acetate butyrate sheet, a product of Eastman Chemical Co.

h—2 of 5 samples failed.

i—3 of 5 samples failed.

j—All 5 samples failed.

for more permanent deformation in the closed end of the cup or less springback. Increases in precharge pressure result in more drag on the flanges and prevent as much material being pulled into the cup. Thus, thinner side walls, smaller circumferential strain and greater axial tensile strains near the open end of the cup giving increased springback are obtained.

As the forming rate increased from 18 to 121 inches per minute:

- Compressive strains decreased in regions 10 and 11 and increased in regions 13 and 14. Changes in region 12 were very small (under 2 percent).
- The effects on axial tensile strain were inconclusive.
- Significantly (50-80 percent) less thinning of sidewalls occurred.
- A pronounced effect on circumferential springback was noted. At position 10 springback increased from 36 percent for polycarbonate, 42 percent for ABS and 50 percent for cellulose. Smaller increases (5-12 percent) were noted for positions 11 and 12.
- Circumferential springback decreased in regions 13 and 24 (the open end of the cup). Decreases were small in region 12 (about 10 percent) in comparison to regions 10 and 11.
- Axial springback decreased.

The above effects are explained by the more elastic response and higher modulus of the plastic material under the higher forming rate. By increasing the punch velocity, less permanent strain is developed in the closed end of the cup producing more springback. The material's higher modulus permits more material to be pulled into the sidewalls resulting in a decrease in the blank diameter and increase in the strain in these regions and a decrease in springback.

Increasing initial blank thickness from 60 to 120 mils:

- Produced little effect on circumferential compressive strain, which generally decreased in the walls and increased in the flange of the cup.
- Generally, only slightly reduced the amount of axial tensile strain and springback. In fact, a two fold increase in blank thickness in polycarbonate and cellulosic produced only a 10 percent decrease in axial springback and 30 percent for ABS.
- The amount of thinning that usually takes place in zones 10 and 11 was reduced while the thickness in the open end of the cup and circumferential springback were slightly increased.
- The springback of cellulosic sheet increased about 4 percent, 13 percent, and 23 percent at positions 10, 11, and 12 respectively. Polycarbonate springback increased from 2.8 percent to 4.9 percent. ABS material seemed to be more elastic and displayed a higher overall tendency to snapback with increasing thickness at all positions.

The decrease in the above strain is attributed to the reduction in forming stress in the cup due to the larger section of the blank.

The increase in circumferential springback with thickness may be because thicker material offers more resistance to forming than the thinner material and less strain is developed. Increasing the thickness of the material appears to make the net deformation during forming more elastic and less permanent.

The contradictory behavior of axial springback to circumferential springback has been attributed to the combination of geometrical constraint with the thicker material. In the axial direction, the material undergoes sharp creases at the bend in the bottom of the cup and between the sidewalls and the flange on the lip. Increasing the thickness of the material tends to make these constraints more difficult to overcome and hence reduces the amount of strain which can be recovered. Circumferential strain on the other hand is parallel to these two creases and therefore there is no constraint to strain recovery. However, the relative permanent deformation is still large and the effects of thickness are relatively small on the overall result of the part.

Effects of configuration:

- Circumferential compressive and axial tensile strains vary considerably depending upon the position in which they are measured. Compressive strain increases from the bottom to the flange in that order (8 percent to 31 percent). The axial tensile strain is the largest of the strains (8 percent to 54 percent) and is the greatest in the sidewall (zone 12) and smallest in the flange.
- Circumferential springback correlates with the increasing circumferential strains. Circumferential springback increases from position 10 to 12 and is in the order of 2.4 to 6 percent. Axial springback (the difference between preset punch penetration and actual height of the cup) is greater than circumferential springback (7 percent to 12 percent) and is influenced by geometrical constraints imposed by creases at the bottom and sidewalls and flange and sidewall.
- In general, thinning of the sheet material occurs in the sidewalls and bottom and thickening in regions 13 and 14 or flange. Normal thickness strains range from -10 percent to +18 percent.
- The material in the bottom of the cup undergoes essentially no strain. Material deformation occurs uniformly in a symmetrical part such as a cup. The grid lines radiating from the central axis of the cup (Figure 15) show almost no lateral movement of material within the sidewalls. The circumferential compressive strain occurs completely uniformly around the walls and flange. Likewise, tensile strains occurring in the axial direction are also uniform around the circumference of the walls, although of changing magnitude in the axial direction along the walls.

Effect of material:

- Polycarbonate had the: most uniform sidewall circumferential springback; highest percent thickness strain in the flange; best overall springback properties; largest circumferential compressive strain; and lowest axial tensile strain in the bottom and the highest at the flange.

- ABS had the: least axial springback; most uniform thickness strain with part position but the highest overall thickness strain; largest tensile axial strain in position 10 and the lowest in the flange (14) - just the opposite of polycarbonate.

- Cellulosic had the highest springback properties, both circumferential and axial, and the lowest compressive strain.

The type material used in this study had no extreme effect on compressive strain and circumferential springback developed. The axial tensile strain and axial springback were of the largest magnitude and varied the most with material.

Coining

DESCRIPTION OF PROCESS

Coining is a mechanical reshaping of part surfaces to improve performance and/or decorability. It is usually a secondary operation used in conjunction with other solid phase forming techniques, such as deep-drawing. It is accomplished by placing a part over a holding jig and bringing a male die to bear on the surface. Examples of coining are applying pressure to inner corners of deep-drawn part flanges to stabilize the configurations, and altering surface appearance by two-surface rippling as shown in Figure 16.

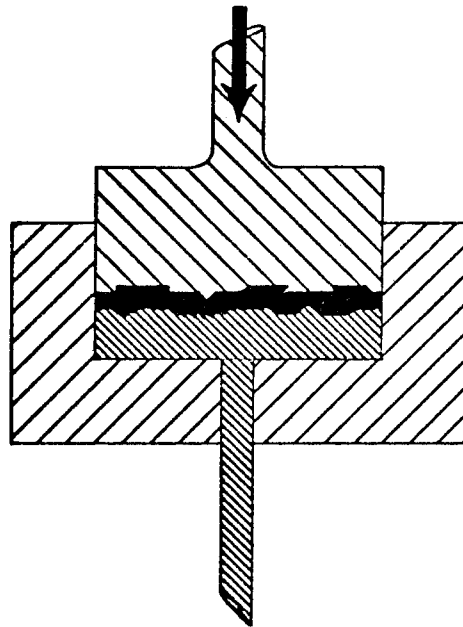

Figure 16. Coining tool (6)

Brake Press Bending

DESCRIPTION OF PROCESS

This process forms a flat sheet into an angle section by the application of force. The material is placed on the female die of a brake press and formed into shape by the downward movement of the punch or male dies. Typical braking dies, air bend, bottom and rubber pad, are shown in Figure 17.

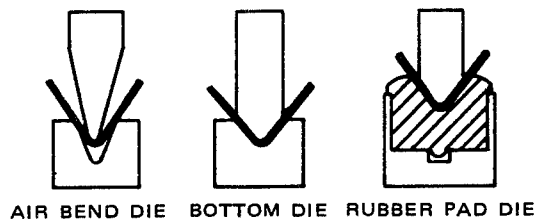

Figure 17. Typical braking techniques (13)

The radius of the formed section is determined by the radius of the punch and the material springback is compensated for by overbending. Overbend can be controlled with the length of the stroke rather than with tool changes.

Rubber pad dies may be used in instances where extra fine surfaces are desired. Air braking has been reported to be the preferred method for forming polyvinyl chloride (13). The only limitations are those imposed by the press capacity and that generally angles cannot be less than six times the sheet thickness (14).

Roll Forming

DESCRIPTION OF PROCESS

Roll forming is the continuous bending of sheet stock by a series of matched driven rolls into the desired shape in a progressive process. The number of rolling stations is determined by the complexity of the item, properties and gauge of the sheet material.

The major limitation is springback which is increased with thinner sheet. For example, it is a severe problem in 25 mil polyvinyl chloride (PVC) sheet. A 40 mil sheet was reported to be optimum for processing PVC by this method (13).

Explosive Forming

DESCRIPTION OF PROCESS

Explosive forming methods involve shaping the material at very high deformation rates obtained by the explosion of a TNT charge located inside a noncompressible media as shown in Figure 18. Concrete, cast iron, and even ice have been used to contain the explosive forming tank. This procedure lends itself to the formation of very large parts.

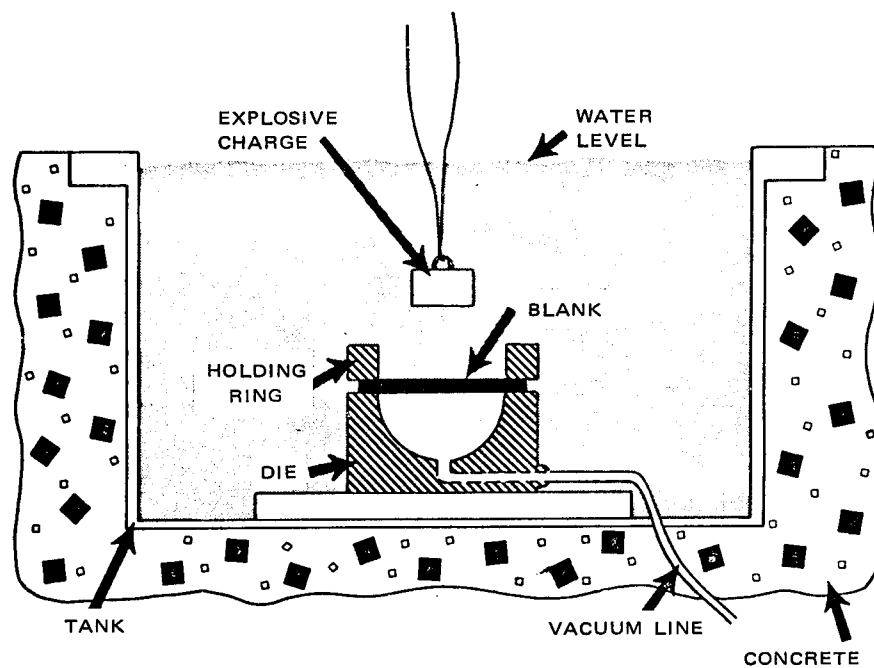

Figure 18. Explosive forming (6)

Spinning

DESCRIPTION OF PROCESS

Spin forming is shaping a part through "compression flow" of material obtained in applying high pressure localized on a small area (spinning tool or rollers) and moving the pressure application point on the surface of the material as shown in Figure 19.

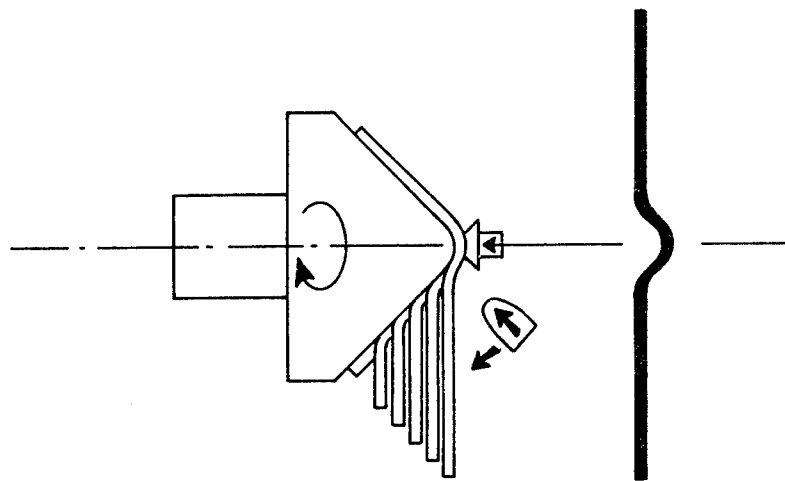

Figure 19. Spinning (6)

DRAWING

In the drawing and deep-drawing processes for thermoplastic sheet, the material is converted into hollow seamless shapes with little if any change in sheet thickness. These processes are in contrast to the conventional thermoforming on thermoplastics in which the material is stretched into the desired shape with attendant decreases in wall thickness. Because of this advantage and because they are amenable to continuous, automated or semi-automated operation, the drawing techniques have received considerable attention in the plastics industry.

DESCRIPTION OF PROCESS

The elementary requirements for thermoplastic drawing include the following:

- A punch to serve as a mandrel around which the sheet is formed.
- A die or drawing to consolidate the material as it is formed around the punch.
- A pressure pad to prevent the material from wrinkling.
- A stripper or similar device to remove the part from the punch.

The punch and die are generally mounted in a die set to maintain alignment as shown in Figure 20. Both hydraulic and mechanical presses are used, but higher production rates are attained with mechanical punch presses.

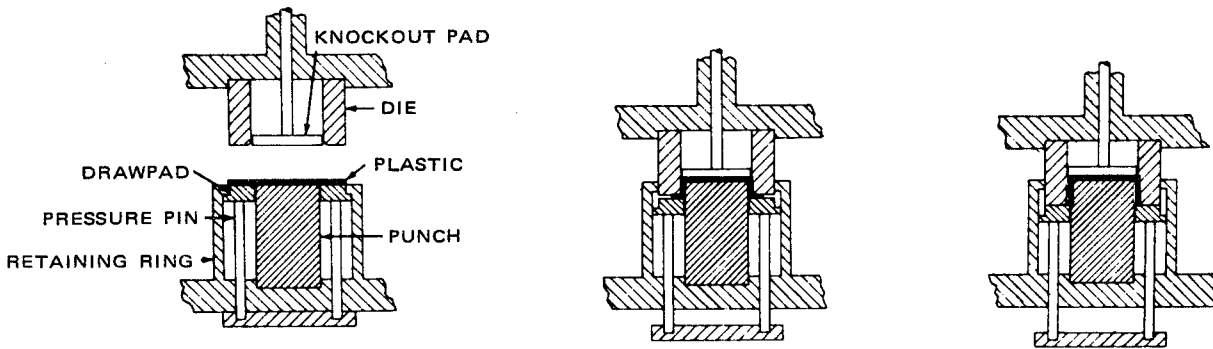

Figure 20. First draw shown at three stages (9)

PROCEDURE AND TOOLING

Sometimes a single drawing operation is the only one required for obtaining the desired shape. In many cases to obtain a smaller diameter and deeper part a second or third draw may be necessary. This may be accomplished using multiple dies and drawpads in sequencing or progressive press operations.

The simplest redraw is shown in Figure 21 and is accomplished by forcing the material down in the same direction as the first draw. The only difference is that the shaped part is placed in a shaped drawpad which automatically centers it on the punch for the redrawing operation.

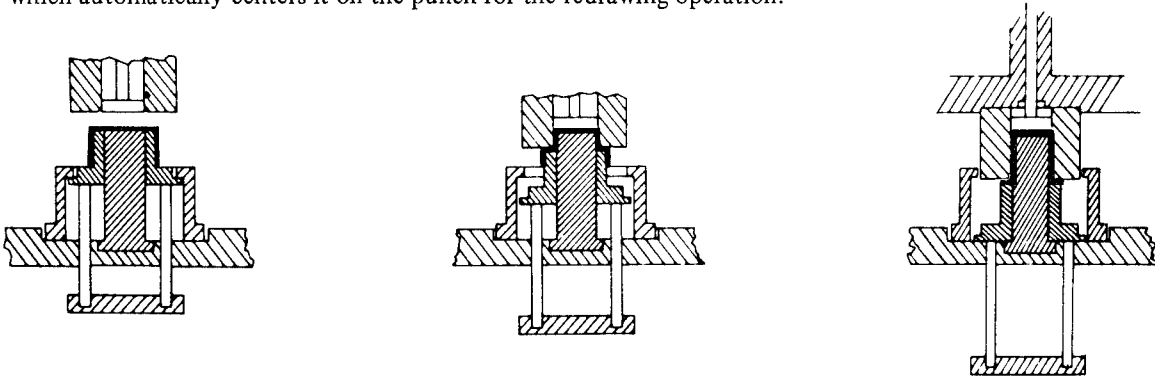

Figure 21. Second draw - straight (9)

Another redrawing operation is shown in Figure 22. This is called an "inverted redraw" because the inner face of the first draw becomes the outer face of the finished part.

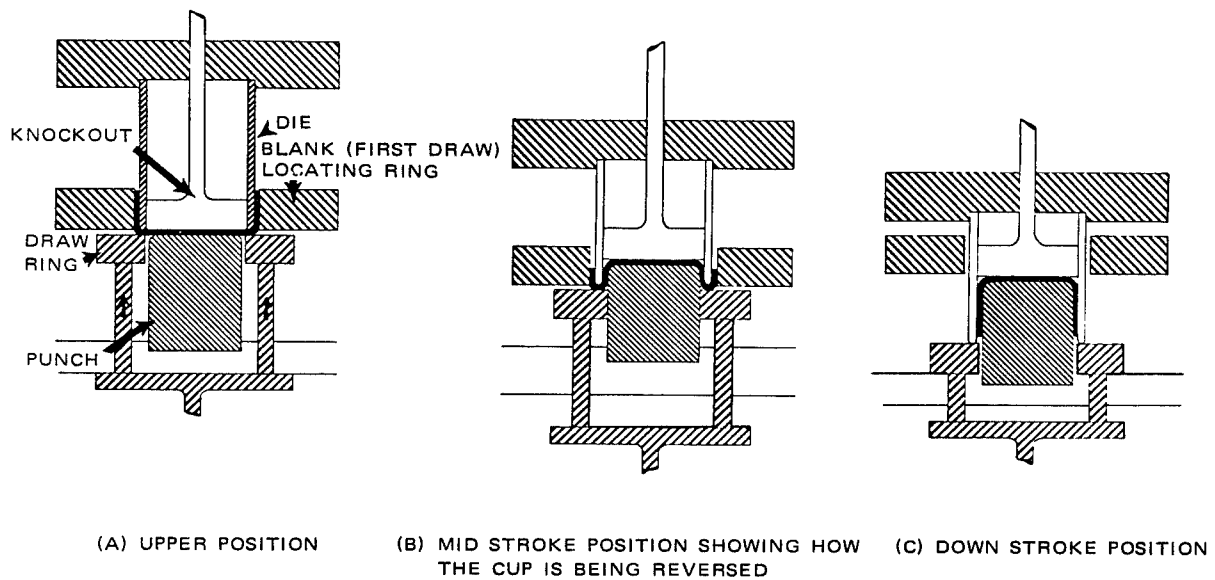

Figure 22. Inverted redraw tool (6)

Depending on part design, it is possible to combine blanking, first and second drawing, and finishing in one operation. This requires multiple drawpads and compound dies - one for each drawing. Figure 23 shows a method for combining a first straight draw and a second inverted draw. The size of the parts which can be fabricated in this operation are limited by the stroke length and daylight opening of the press.

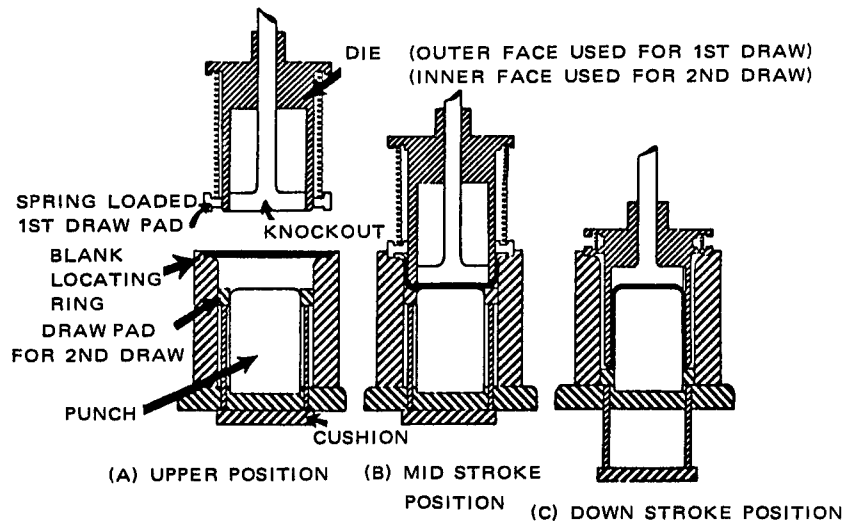

Figure 23. Combination tool for successive 1st draw and 2nd inverted draw in one operation (6)

Another example of combining operations is shown in Figure 24 (a) and (b). Here blanking, drawing, wiping, coining and curling are performed in one operation to form a cup. The right side of Figure 24 (a) shows the up position and the left side represents the down stroke of the press. The mid-stroke operation is depicted in Figure 24 (b).

Blanking (Figure 24) takes place when the shearing edge of the blanking punch (8) contacts and cuts the material laying over the shearing member (4). The circular blank is then pressed between the die (8, 9) and the drawpads (5 and 14). Due to the pressure maintained in the upper chamber (15) and the shoulder provided by the pad (8) on the die member (7), the two pieces (8 and 9) start moving down simultaneously. The drawpad (5) through the pressure of the air cushion and the shoulder located in its lower portion, maintains the sleeve (14) in the position indicated in Figure 24 (b).

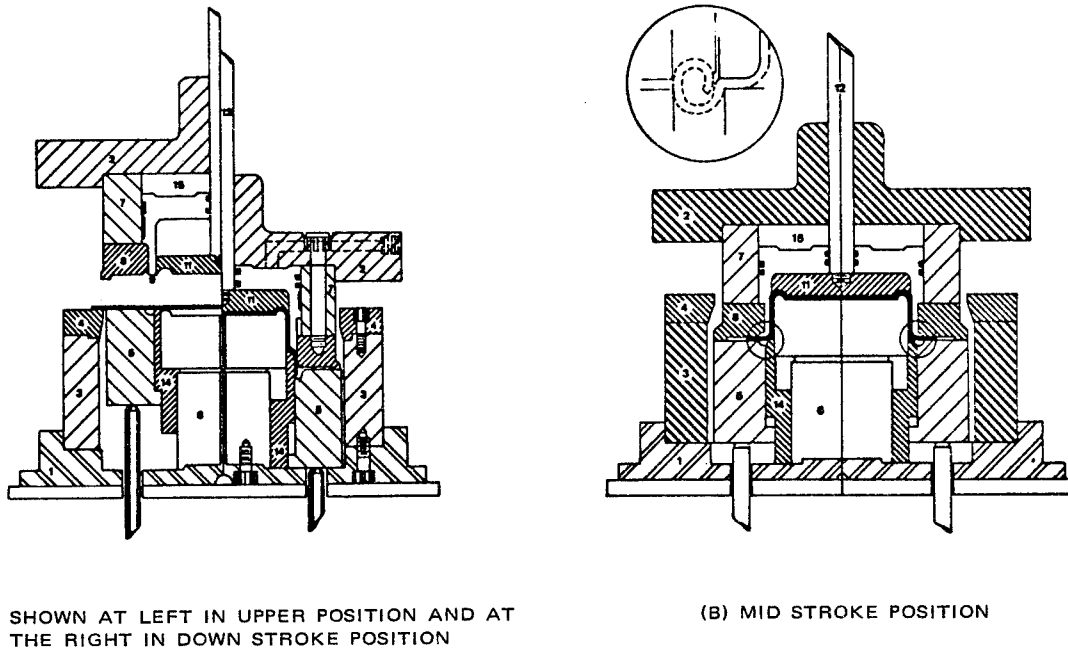

Figure 24. Tool for combination blanking, drawing, wiping, coining and curling (6)

As the press continues its down stroke, the material starts to form around the punch (6) and the dies (8 and 9). The drawpad (5) and the sleeve (14) move down simultaneously until the sleeve bottoms on the base (1) of the tool as shown in Figure 24 (b). At this moment, a cup with a flat flange is formed and the material is strongly pressed between the sleeve and the die (9). Continuing the down stroke, the flat flange of the cup is wiped down around the sleeve (14) which acts as a drawing punch and the inner face of the die (8). A shoulder on the cup is thus formed until the press arrives at down stroke. At this moment, the knock-out pad is forced "solid" against the punch, coining the material and forming the bottom shape of the cup (Ref. 6).

When the press starts its motion upward, the contact between the sleeve (14) and the die (9) is maintained by gas pressure in the chamber (15) and only the drawpad (5) and the die (8) are moving simultaneously. During this movement, the material which has been wiped around the sleeve during the down stroke is forced to shape into the toroidal chamber provided partly in the drawpad (5) and die (8), forming the desired curl around the top of the container (Ref. 6).

When the die (8) shoulder hits the corresponding shoulder on the die (9), both parts start to move on the drawpad (5), which hits the corresponding shoulder on the sleeve (14). Consequently, all four parts (8,

9, 5, 14) move up together with the formed container. At the top of the stroke, the knock-out rod hits a fixed bar located on the press and ejects the container from the die (Ref. 6).

In production it is necessary to feed the sheet, strip or blanks into the press automatically. Automatic gripper and roll-type feeders have been used with the gripper type preferred. Standard pay-off reels for coiled sheet have performed satisfactorily.

Parts which require multiple operations can be transferred in a web, by hand loading, conveyor, air blasts or by finger-type transfer systems. The method selected depends on the part design, quantity of parts to be produced and the thickness of the sheet. A web carrier (see Figure 25) is usually used where several draws are necessary. During the last operation, the finished part is trimmed from the web.

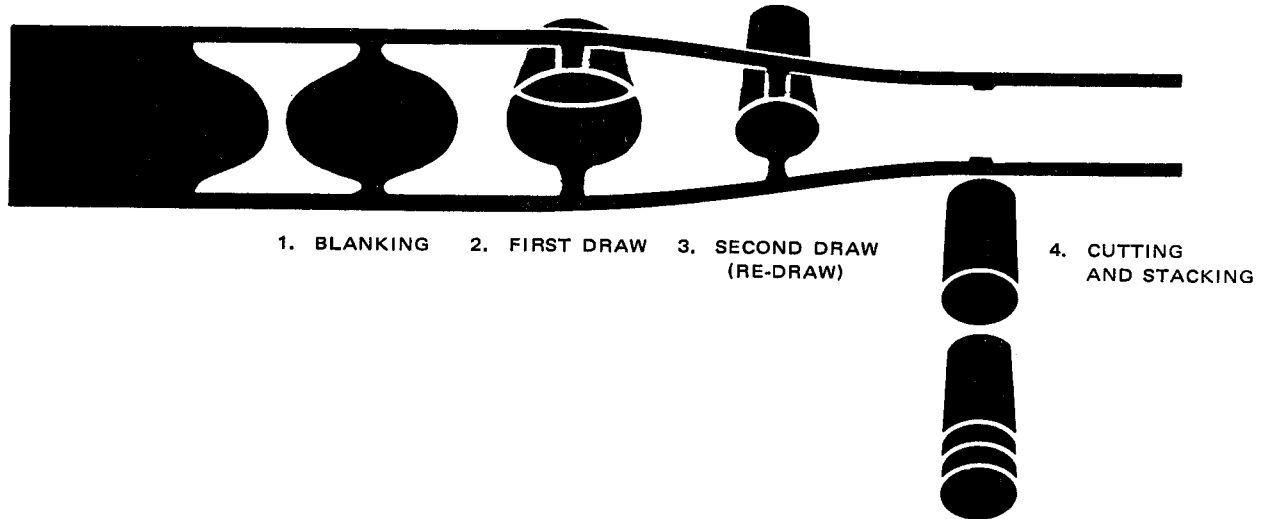

Figure 25. Web carrier (9)

Temperature and Lubricant - Recommended temperatures for deep drawing sheets depend on the material. For thin ABS sheets it is between 60° - 100°F. On thick sheet 1/16 to 1/4 inch it is possible to go up to 200°F (15). Although heating the material reduces springback, caution must be exercised not to obtain too high temperatures. Higher temperatures will cause the side walls to stretch rather than flow with undesirable thinning of sections.

Both sides of the blank surfaces must be lubricated before drawing. The surface which contacts the female die must receive a heavier coat of lubricant than the opposing surface in contact with the drawpad. The lubricants can be applied by spraying, rolling or dipping. Mineral oil, soaps, and some waxes work well but cannot be economically removed.

Lubricants fall into two categories, aqueous and nonaqueous. The aqueous is usually used on "at-the-press" applications and the nonaqueous as a precoat prior to coiling. It is possible, however, to use either type in both applications.

The following are some lubricants which have been developed for ABS (Cycolac MS and Cycopac 155) sheet (9). Bruko D-491 is recommended for flexible plastics 11 to 15 mils. It is aqueous, odorless and tasteless, and is transparent and non-tacky when dried. The lubricant can be readily removed by a warm water rinse, water spray impingement or alkaline cleaning systems.

Bruko D-492 is a nonaqueous solvent solution of fatty ester and fatty amide lubricants designed for pre-coating light gauge sheet prior to coiling. Pre-coated stock can be stored indefinitely until ready to be cold formed. After evaporation of the solvent, the resulting dried film is hard and non-tacky so that it won't attract or retain dust and dirt particles. However it flows under the drawing pressures and provides adequate lubrication. The residual film can be removed by mild solvent, emulsion cleaner or detergent wash.

Bruko D-493 is an aqueous emulsion of highly refined fatty acid esters. It may be applied at the press by any conventional application technique. After complete drying, the residual film on the drawn part is transparent, non-tacky and free of odor or taste. Dried film will not darken and may be removed by simple warm water rinse or spray.

These lubricants have been approved by the Food and Drug Administration for food packaging.

Forming Cycle -

Drawpad Pressure - The drawpad or blank holder pressure is one of the most important operating factors and must be established by trial and error for each new die design. As a starting point the drawpad pressure should be set at 20 percent of that used for aluminum or 10 percent of that used for steel (9).

The pressure can be generated by rubber pads, springs, hydraulic cylinders or air cylinders. The pressure will be influenced by: the initial surface area of the blank which is confined between the die and the drawpad; the linear speed of the die at the beginning of the draw; the surface finish of the die, drawpad, and sheet; and the amount and type of lubrication used. Generally, the initial pressure on the blank or the drawpad will range between 50 and 400 psi (15).

When forming circular parts, the drawpad pressure should be uniform at all points around the periphery of the die. A change in die geometry will require a change in drawpad pressure. If too little pressure is used, wrinkles will form. If too much pressure is applied, the bottom will fracture. The range from the point where wrinkles start to where the part will fracture depends on clearance, the punch nose radius and die radius. Usually the best practice is to maintain the drawpad pressure as close as possible to fracture rather than to the pressure which allows wrinkling.

Drawing Speed - The speed of the ram is not constant due to the motion generated by the crank or cam of the mechanical press. Parts have been reportedly formed in experimental equipment where the ram was traveling at a rate of 190 feet per minute. This is the highest ram speed attainable on a six inch stroke press running at 120 strokes per minute. No concentrated work has been reported at higher speeds since most standard mechanical metal drawing presses do not exceed 200 feet per minute. Lower speeds for drawing such as obtained on hydraulic presses usually form parts but the springback is higher than on the higher speed equipment.

Production Rate - It is common practice to gang a number of dies together in a press with a large bed area in production. For example, five dies can be set on a diagonal and the press run at 100 strokes per minute to produce 500 parts per minute. The dies are placed on the diagonal to reduce the amount of trim scrap. A minimum spacing of 1/8 inch between blanks is usually required (15).

Tooling - The basic tooling for drawing including a punch, the drawpad, the die and the ejector were shown in Figure 20. The diameter of the steel punch, around which the material is formed, will be approximately the inside diameter of the part. The punch nose radius can range from four to fifteen times the material thickness depending on part design.

The inside diameter of the die is approximately the outside diameter of the part. It should be made of high quality die steel hardened to Rockwell 60 range and highly polished. Soft dies become scratched, causing rough surfaces on the finished part. Also, rough surfaces cause non-uniform flow of material into the die. On occasions milder steels are required as for improved toughness or to reproduce greater detail in the part. These surfaces may be case hardened or nitrided and often fall in the Rockwell hardness C scale range 65-78.

The die must be well vented to eliminate air entrapment. Entrapped air can cause blisters, fractured and/or distorted parts. The die radius can be varied from four to ten times the sheet thickness. The clearance between the punch and die should not exceed the material thickness plus a 10 percent allowance for variations in the sheet thickness. Too sharp a radius on either the punch or the die opening will hinder the normal flow of material, causing uneven thinning of the part walls and material failure (see Figure 26).

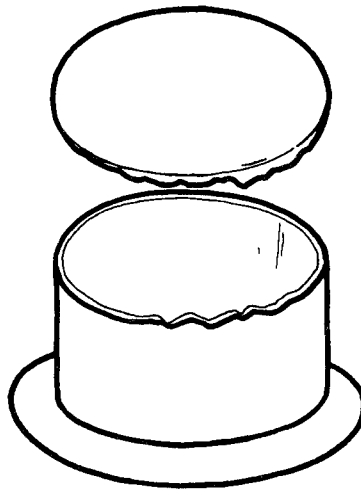

Figure 26. Fractured part bottom resulting from too sharply radiused punch (9)

The end radii of redraw punches must also be carefully blended for the normal flow of material. Punch radii that are too small will produce rings or waves near the part bottom which result in wall thinning. This will become more pronounced with each redraw. Abnormally sharp radii restrict material flow, causing straining or stretching as shown in Figure 27.

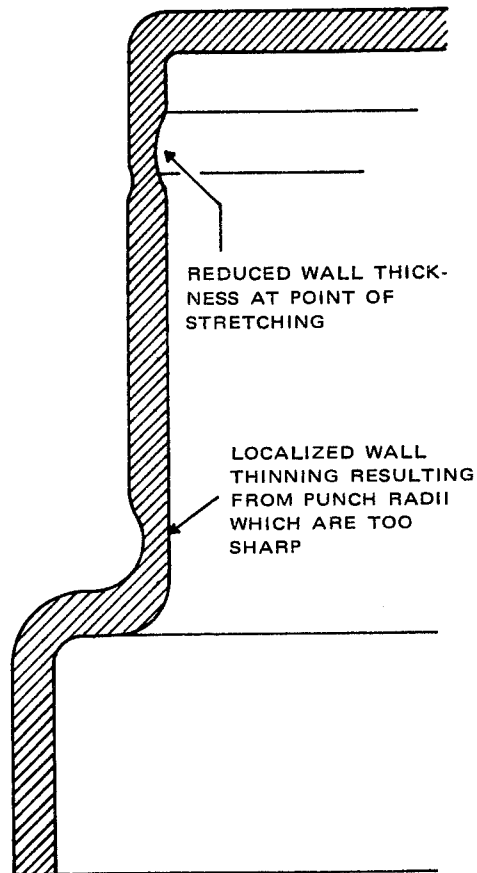

Figure 27. Wall distortion due to too sharp and too small punch radii (9)

The punch must be centered and correctly aligned with the die for even distribution of material flow around the part being formed. Any degree of misalignment will prevent material flow, distort the flange and cause non-uniform wall thickness as illustrated in Figure 28.

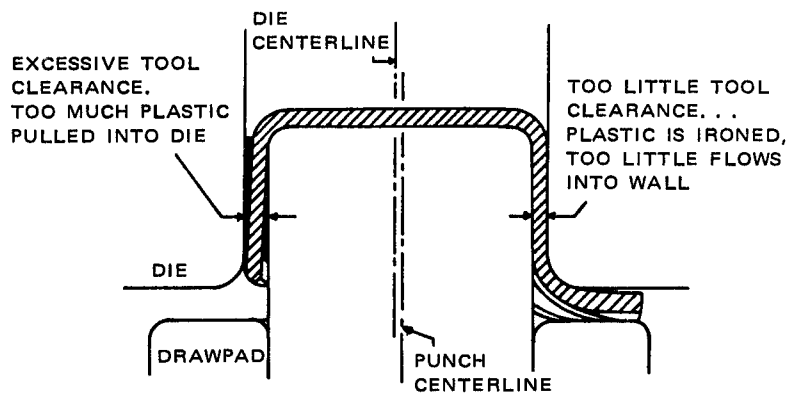

Figure 28. Distorted part resulting from misaligned punch and die (9)

The periphery and base of the punch nose should be roughened to avoid multiaxial deformation under the punch. A 50 to 55 microinch root mean square roughness has been recommended for acrylonitrile-butadiene-styrene. This requirement is more or less independent of material blank roughness or lubrication. One order less of roughness can permit material flow under the punch nose and produce an unsatisfactory item (15).

PART DESIGN AND QUALITY

In general part design and quality will depend on the plastic material selected, the tooling and forming cycle as well as design factors. However, the following general guidelines have been determined for optimum results.

The material blanks should not exceed the diameter of the die and drawpad. Material which overhangs will enlarge as it is compressed between the die and the drawpad. This enlarged material will resist flow and cause the material to stretch between the punch and die resulting in a defective product.

The blank diameter is determined by the design and number of operations required to produce the part. One method of blank development is to calculate the surface area of the finished part and use this area to establish the approximate diameter of the blank. For example, a finished part having a total surface area of 15 square inches will have a blank area of 15 square inches or equivalent to a 4.361 inch blank diameter for a round drawn part.

Tables from metalworking handbooks can be helpful in determining the approximate blank diameter for round parts or calculated from the following formula:

$$D = \sqrt{d^2 + 4dh}$$

Where D = blank diameter
 d = part diameter and
 h = height of part.

Such values are made assuming a perfect draw and the surface area of the formed part being identical to the surface area of the blank. They should be used as starting points to determine the exact diameter blank size. There are no simple tables for determining blanks for nonround parts. It is suggested that the same rules and formulas be used that have been developed for metals.

The reduction in diameter from blank to part should not be excessive. Excessive reduction results in extreme thinning of the material to the point where the bottom tears away as the punch extends as illustrated in Figure 29. Reduction for most materials should not exceed about 45 percent in the initial drawing and about 35 percent in subsequent redraws.

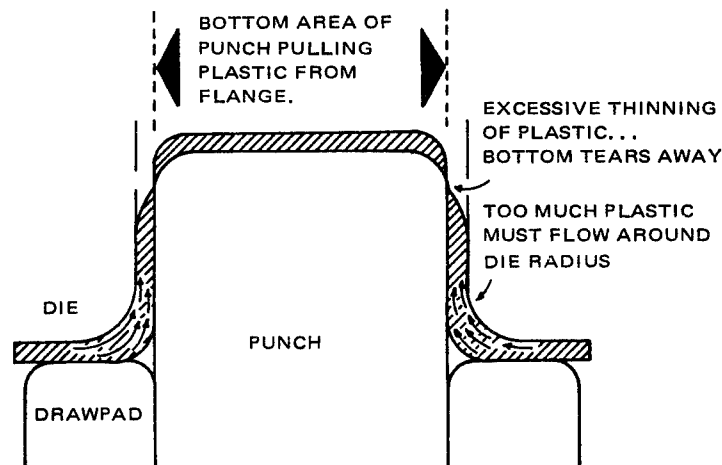

Figure 29. Cross-section of part formed with excessive reduction from blank to part diameter (9)

The following formulas are used to calculate the percent reduction in blank diameter and the approximate part height:

$$\text{percent diameter reduction} = \frac{D_B - D_P \times 100}{D_B}$$

where D_B = blank diameter
 D_P = part or punch diameter

$$\text{part height} = \frac{S_B - (S_F + S_P)}{\pi D_P}$$

where S_B = surface area of blank
 S_F = surface area of top flange
 S_P = surface area of bottom
 D_P = diameter of part

An allowance of 4 to 10 times the material thickness to the ideal radius should be used for corners. The minimum taper in mechanical deep draws is 0.5 degrees and the maximum is 10 degrees on thin stock.

Sheet thicknesses which can be drawn vary for different materials. ABS, for example, has been drawn over a range from 0.005 to 0.250 inches thick (9). In any case, the use of uniform sheet stock that is within specified gage tolerance limits (usually 10 percent) is necessary to successful drawing operations. Deviations above or below these limits result in deformations of the part (see Figure 30) which is progressively magnified in redrawing. ABS sheet 0.005 to 0.250 inches thick has been successfully drawn (9).

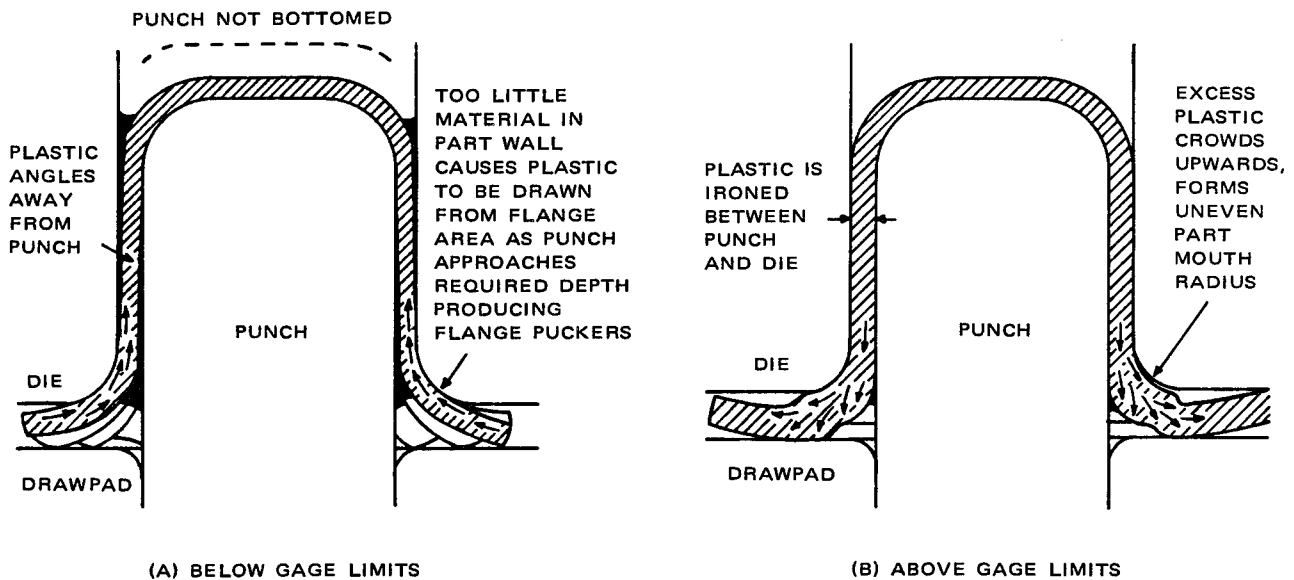

Figure 30. Drawing operations as adversely affected by sheet gage limits (9)

The sheet surface must also be completely free of flaws such as score marks, spills, blemishes or other defects. Such irregularities impair control of the draw and result in an uneven flow and deformation of the material resulting in tearing. Figure 31 shows the magnification of score marks during drawing.

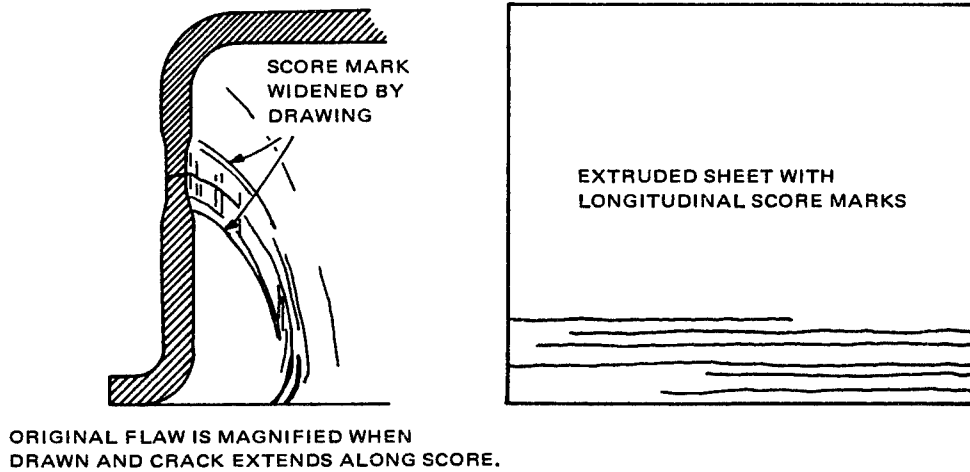

Figure 31. Drawing operations adversely affected by score marks (9)

Blanking tools should be kept very sharp. The presence of burrs, nicks or raggedness on the blank's outer edge will cause a cracked uneven wall and a distorted rim on the part. (See Figure 32) These flaws will also be increased with subsequent redrawing.

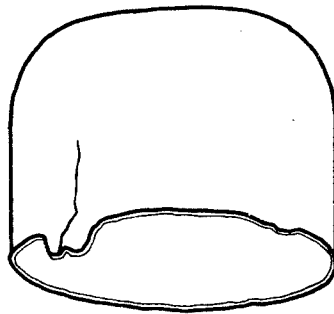

Figure 32. Part formed from damaged blank with flaws in periphery, showing typical resultant earing and elongation of nicks. (Note cracking down shell wall. A burred condition will cause similar problems.) (9)

Flow considerations are different in rectangular or irregular shaped parts. (See Figure 33) Some parts of the blank will be submitted to considerable drawing while other sections will require only simple bending. To achieve uniform wall structure, it is necessary that the blank be completely confined and under very close control between the die wall and punch surface during the entire drawing operation.

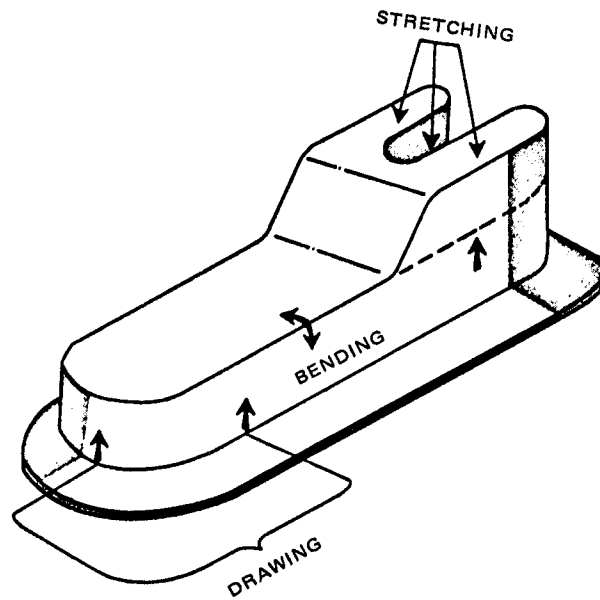

Figure 33. Complex shape with a combination of drawing, stretching and bending (6)

DECORATION AND PRINTING

It is possible to decorate both sides of the sheet in the flat and then form a part with the decoration in the wall of the part. The print pattern must be distorted to reflect the compression and elongation of the sheet during the drawing operation. Since a mathematical distortion printing rule is difficult to establish because the distortion is constantly increasing with the distance from the center of the blank, two techniques for round parts have been used which give acceptable results.

The technique which gives the most satisfactory results is to make a grid pattern with permanent ink on the flat blank as shown in Figure 34. The dimensions are recorded and the blank is drawn into the die to be used. The grid dimensions of the part are recorded and the change converted to either plus or minus percentage changes. The percentage change at the lower edge of the part will be small and very large at the

top near the lip of the part. An artist or draftsman can use these percentage changes to lay out the decoration. The radial lines become parallel in the side wall and the circular lines become spaced further apart.

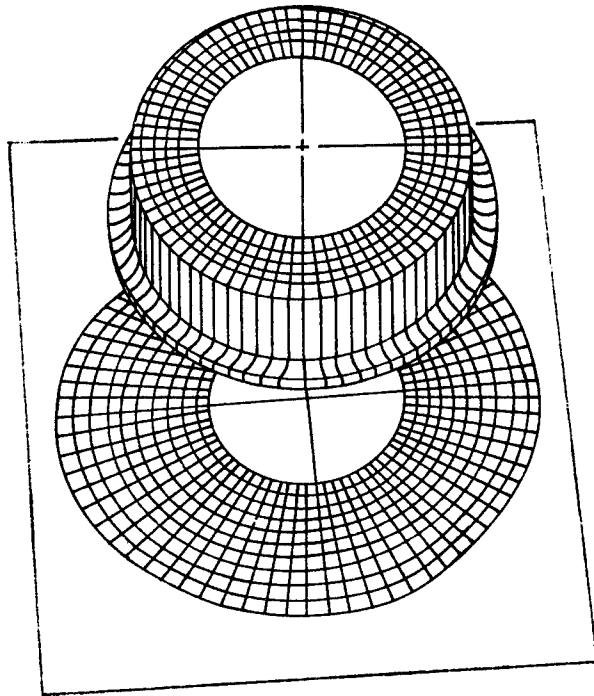

Figure 34. Grid pattern (15)

The other system is to form the part from stress relieved sheet. The artist applies the desired decoration to the part. The decorated part is then placed in an oven until the part recovers to a flat sheet. The master for the printed rolls can be made from this flat sheet. The accuracy of this technique is not as good as the first technique but it may be satisfactory for many applications.

Parts can also be decorated after forming. However, pre-decoration is more economical because flat sheet can be printed much faster and more economically than a formed object.

Flexography, rotogravure and lithography are the printing processes that have been employed for decorating flat sheet for deep drawing application. Inks for these printing processes have been formulated with sufficient adhesion, flexibility, stretchability, compressibility and slip to withstand the stresses applied during the drawing operation.

EXPERIMENTAL INVESTIGATIONS OF SOLID-PHASE FORMING

A series of experiments were conducted to analyze the cold forming of acrylonitrile-butadiene-styrene (ABS) sheets (16). The studies were based on high speed testing in which a Plastechon High Speed Tester was employed to activate a miniature cold forming jig.

Determined were the load developed, work required (total area under load displacement trace), range of speeds required for an acceptable part and the quality and dimensional stability of the formed cup. These cold forming properties of the ABS polymers were then compared with the corresponding high speed puncture, multiaxial drawing, and tensile properties of extruded ABS sheet to evaluate the relative utility of different high speed testing procedures for characterizing cold forming performance. All procedures were carried out at $23 \pm 1^\circ\text{C}$ and 50 ± 10 percent relative humidity without heating the sheet; however, strain recovery was determined at an elevated temperature.

To study the effect of ABS structure, four polymers based on the same diene were investigated. These formulations (Table 3) were unpigmented to facilitate visual observation and were uniformly lubricated with an oil emulsion to simulate normal drawing conditions. Each was extruded into 10 mil thick sheet.

Table 3. Structural Characteristics of ABS Polymers (16)

Polymer	Wt % Diene	Copolymer \bar{M}_n	Relative Interfacial Adhesion	Preparation
ABS I	20	37,000	1	In-situ polymerization
ABS II	20	70,000	0.6	Polymer blend
ABS III	13	49,000	1	In-situ polymerization
ABS IV	30	49,000	0.6	In-situ polymerization

From this study, a 45 percent maximum diameter reduction for ABS was confirmed. It was also determined that blank lubrication as well as the controlled roughness of the punch nose were prerequisites for successful drawing.

A sequence of progressively deeper draws was made to gain insight into the mechanics of cold forming and polymer behavior. The draw was terminated at specific points and the partially formed cup was examined for geometry and stress-whitening. Figure 35 shows the deformation of the specimen blank at four progressive stages of drawing in relation to the load-displacement oscilloscope trace obtained during each stage of drawing.

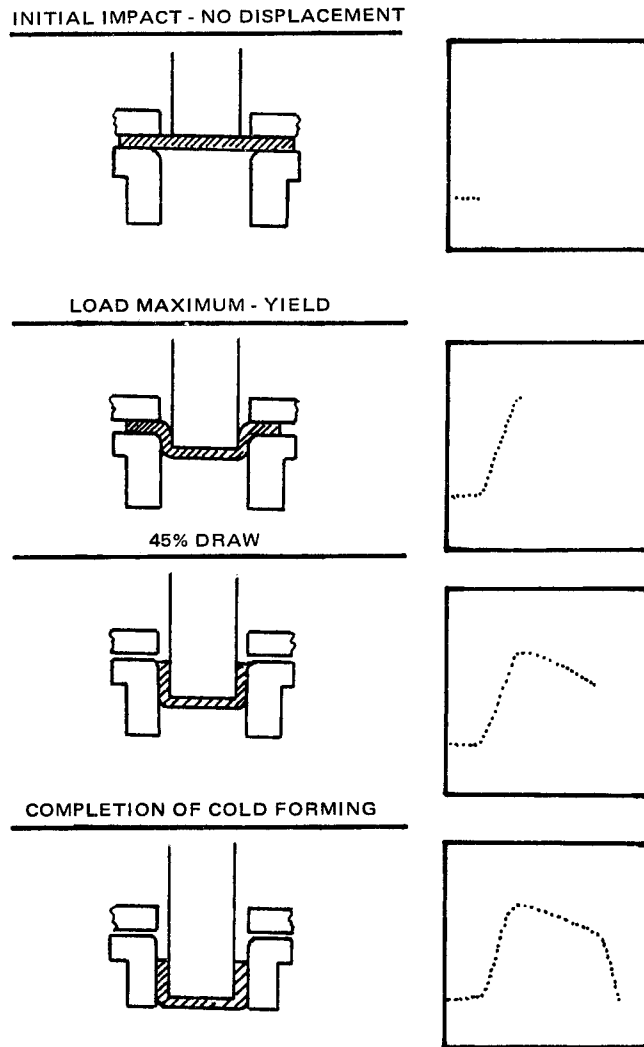

Figure 35. Progressive cold-forming of extruded ABS I below 100 in./min. (16)

Initially, two rings of stress-whitening were observed where the nose of the punch and the die first impinge on the specimen. This indicates that the molecular processes causing whitening are operative in a highly localized manner. After the initial impact, the polymer is subjected to a double bending deformation around the nose of the punch and the edge of the die which broadens the two rings of stress-whitening. In this stage of forming the load increases with deformation which is attributed to plate bending. This theory requires that a radial and a tangential stress be applied at the edge of the uniformly loaded plate specimen (16).

Radial stress at the edge of a uniformly loaded circular plate during elastic deformation is expressed as:

$$S_r = \frac{W}{4 \pi t^2} \quad (1)$$

where: w is applied load
 t is specimen thickness

The tangential stress around the perimeter is related to load and specimen thickness for an elastic deformation by the equation

$$S_t = \frac{W}{4 \pi \mu t^2} \quad (2)$$

where: μ is the Poisson ratio of the material.

From equation (2) the tangential stress should increase faster than radial stress at a given forming speed. For successful cold-forming where no change in thickness has occurred, the tangential and radial stresses must be balanced. Too high a radial stress will lead to fracture around the wall of the cup and too low a tangential stress will cause wrinkling. Tangential stress fractures will be radial.

The radii of the edge of the punch nose and die are deemed critical to successful completion of plate bending. A radius of six times specimen thickness was determined as a result of extensive full scale cold-forming (16).

Little or no movement of specimen occurred under the drawpad during bending. As the punch continued into the die, the load continued to increase and the plastic was stretched uniaxially. Cold working occurred only in a small annular section and there was little material deformation under the base of the punch.

No relief of the tensile stretching process occurred prior to the development of maximum load at low speeds, although some slippage may occur prior to maximum load at higher speeds. The material reaches a yield condition as a result of the combined bending and stretching which reduces to tensile-compression deformation.

Because the specimen does not move under the drawpad until maximum load is reached (at least at slower speeds), the maximum in the load-displacement curve will not be significantly affected by increasing hydrostatic pressure or drawpad pressure. However, the effective yield strength of the material and resistance to crazing will increase throughout the latter stages of drawing due to the compression of the material under the drawpad.

As the deformation at the yield point is predominantly uniaxial tensile stretching of the wall of the cup, the plastic must be capable of tensile yielding at high deformation rates. It is evident from the high speed tensile measurements made on tensile specimens cut from the extruded ABS sheets that load after yield remains essentially constant at typical forming speeds. The observed decrease of load after the maximum during forming was consistent with a constant radial stress being off-set by slippage of the plastic under the drawpad and reduction of the clamped area (16).

There was a marked decrease in load when the specimen periphery was free of the drawpad, but the decrease was not instantaneous. The finite time for load to decay to zero with subsequent travel of the punch was attributed to the viscoelastic recovery of the polymer. The recovery time will be shortened as material temperature increases.

The thickness of the wall of the formed cup remained the same as that of the base of the cup which was not stretched. This was not unexpected considering the small decrease in cross-sectional area on tensile stretching ABS plastics beyond yield and the absence of localized necking.

Figure 36 compares the puncture and cold forming load-displacement curves at increasing punch speeds. These curves are identical at punch speeds up to 300 inches/minute where the load maximum was the same with a punch displacement of 0.1 inch. The maximum in the cold forming oscilloscope trace was due to a puncture-type yield mechanism. There is some discrepancy between puncture and forming load at speeds above 300 inches/minute. At 1000 inches/minute there is no indication of a yield maximum during puncture, but the forming load does pass through a maximum at a greater punch displacement. Therefore, slippage occurs under the drawpad prior to maximum forming load at punch speeds in excess of 300 inches/minute. This accounts for the observed punch travel beyond the displacement of 0.04 inches causing fracture of the specimen during the puncture test to reach the maximum-forming load at a displacement of 0.075 inches.

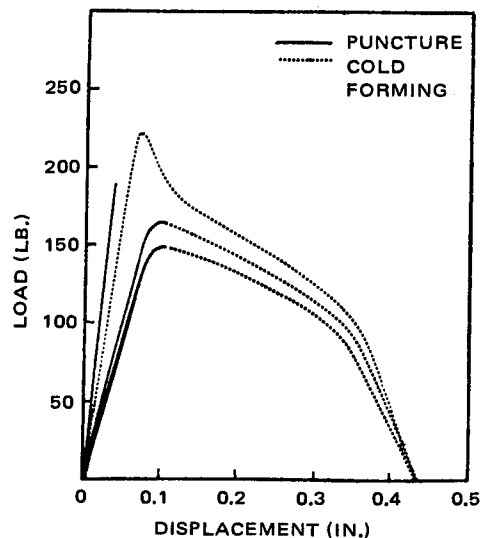

Figure 36. Load versus displacement during puncture and cold-forming of extruded ABS I (16)

The cold forming strength and puncture strength (maximum puncture load divided by specimen thickness) are shown in Figure 37. Up to a punch speed of approximately 300 inches/minute both strength

parameters increase almost logarithmically with test speed. At higher forming speeds the polymer response is more elastic and will depend more on the energy dissipation by the rubber particles and the molecular entanglement of the ABS formulation.

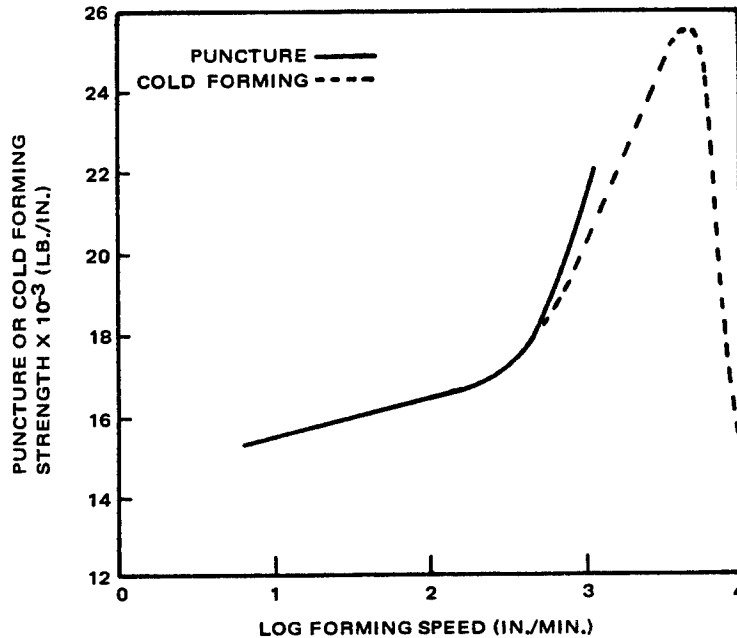

Figure 37. Puncture and cold-forming strength of extruded ABS I (16)

Figure 38 compares the forming strength and range of forming speeds for the three cold-forming ABS polymers.

ABS I had the highest forming strength and gave the best cold formed cups at test speeds up to 1000 inches/minute. The cups had the best retention of punch geometry with a minimum of deformation on removal from the die, a glossy appearance, and showed minimum stress-whitening.

The maximum forming speed for ABS II was 300 inches/minute and the stress-whitening was more pronounced in the cup wall. The maximum speed which could be used to form a cup from ABS IV without fracturing was 4000 inches/minute. However, above a punch speed of 2000 inches/minute the bottom of the cup was appreciably stress-whitened in addition to the whitening in the cup wall. Also, the cups were very flexible and underwent severe springback. ABS III (the lowest diene content) failed to cold form at any speed.

These results indicate that there is an optimum elastomeric graft content for the ABS which provides the most desirable latitude of forming speed with the best overall finished part properties. However, the elastomeric graft content alone does not provide for optimum part properties but does control the part

rigidity. Modifying the structure of the elastomeric graft phase to decrease interfacial adhesion with the copolymer matrix was found to increase stress-whitening in the formed cup and reduce the range of forming speeds.

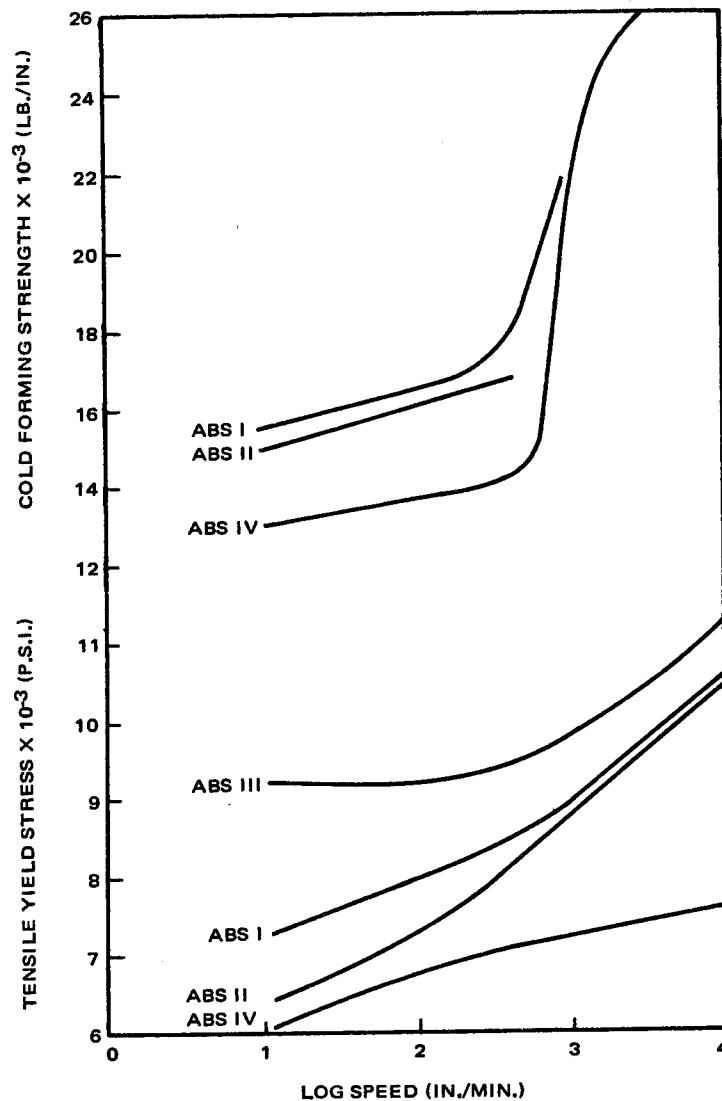

Figure 38. Tensile yield stress and cold forming strength of extruded ABS polymers (16)

The dimensional stability of the cold formed cups were measured at room temperature on the three cold forming ABS polymers over a 155-hour period. Most of the increase in average cup diameter occurred

in the first minute. After 24 hours the rate of diameter increase leveled off and there was only a gradual subsequent increase. No well-defined trend in strain recovery versus forming speed was found. Parts formed at different speeds were subjected to a 60°C strain recovery test. After one hour at this temperature, no further increase in part diameter was observed irrespective of forming speed.

Instantaneous springback and subsequent springback at elevated temperatures were most severe for the highest diene content ABS polymer. This was attributed to the appreciable interaction of the rubber particles at this rubber level. Reducing the interface adhesion and increasing the molecular weight of the continuous matrix at the 20 percent diene level resulted in more stress-whitening in the wall of the formed cup and minimized springback at elevated temperatures.

The high speed tensile tests were conducted on microtensile specimens. It is interesting to note (see Figure 38) that ABS II has lower tensile yield strength than ABS I at all test speeds even though the diene content of both polymers was the same. Also, ABS III (the lowest diene formulation) which could not be cold formed at or above 10 inches/minute, had the highest yield stress at all speeds. As can be seen, there was good agreement between the order of yield stress of the I, II and IV ABS's and the order of their cold forming strengths.

Figure 39 compares the tensile elongation of the four polymers. The break elongations of the 13 percent diene ABS III were very low at all test speeds. Those of ABS I and ABS II were very similar at speeds above 200 inches/minute, but the lower yield stress ABS II elongated less than ABS I at test speeds above 30 inches/minute and rapidly increased in elongation at speeds lower than 30 inches/minute. The two apparent anomalies observed for ABS II at lower test speeds were attributed to poorer interface adhesion resulting in the reduced efficiency of the dispersed elastomeric particles in combating crack propagation in the glassy matrix above 30 inches/minute and the higher orientation in the continuous matrix below 30 inches/minute. The higher molecular weight of the ABS II continuous matrix in combination with lower internal frictional heating (because of the poorer interface adhesion) are both conducive to orientation of the rigid copolymer at low speeds.

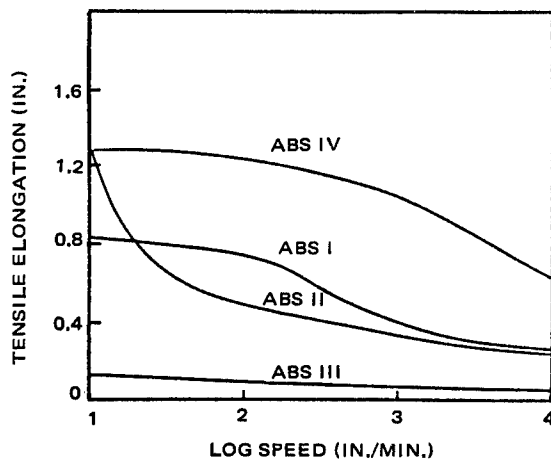

Figure 39. Tensile fracture elongation of extruded ABS polymers (16)

At speeds greater than 200 inches/minute (strain rates greater than $1.3 \times 10^4\%$ /minute) tensile elongation appears to be the best criterion of cold formability.

Specimens 1.5 inches square were cut from each extruded ABS sheet. The specimen without lubricant was clamped in the high speed puncture unit which was fitted with a 0.875 inch diameter punch. Oscilloscope traces of drawing load versus displacement were obtained at punch speeds from 10 up to 10,000 inches/minute.

Only the 30 percent diene ABS IV passed through a load maximum indicative of yielding at high punch speeds near 10,000 inches/minute. All the drawn specimens stress-whitened under the punch nose with ABS IV being the most extensive and ABS III the least. ABS I, ABS II and ABS IV had ductile radial stress failures. ABS III fractured around the clamped edge of the specimen and directly across the specimen under the punch nose. This latter type of fracture is indicative of tangential stress failure which is consistent with a low Poisson's ratio (16). ABS IV underwent very uniform multiaxial drawing with extensive stress-whitening and fractured around the periphery of the drawn area.

Although there appears to be little merit in using ultimate multiaxial drawing strength as a criterion for cold formability because of the marked differences in drawability of the four ABS polymers, it did clearly differentiate the non-forming ABS III polymer from the three cold forming ABS polymers.

The curves of ultimate drawing strength (maximum load divided by specimen thickness) versus drawing speed are shown in Figure 40 and also clearly differentiate the non-forming ABS III polymer from the three cold forming ABS polymers.

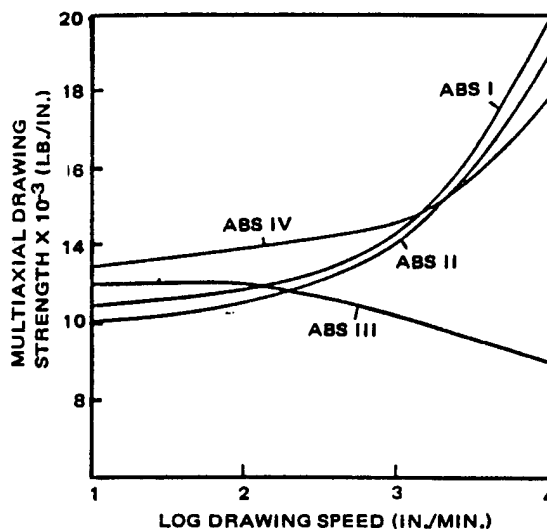

Figure 40. Maximum drawing stress of extruded ABS polymers (16)

The depth of draw attainable with each extruded 0.010 inch ABS gives a clear differentiation of polymer cold formability. This distinction is shown in Figure 41. The range of cold forming speeds correlates very well with multiaxial drawability at all test speeds. There is also a very close correspondence between tensile elongation (Figure 39) and multiaxial drawability except at speeds below 30 inches/minute when uniaxial tensile deformation is affected by orientation (16).

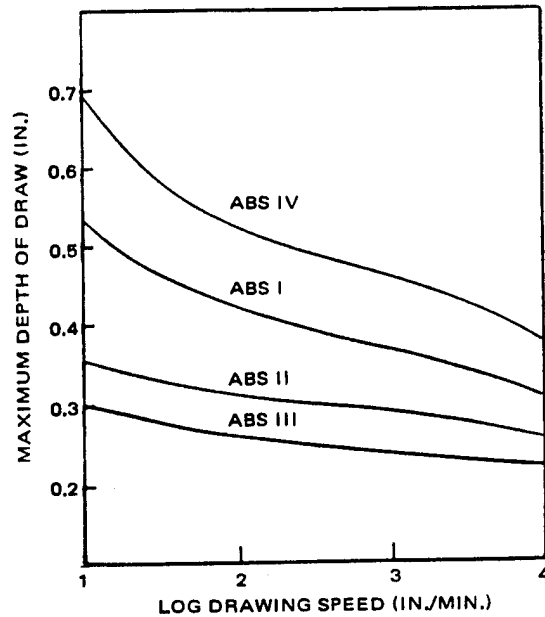

Figure 41. Maximum depth of draw of extruded ABS polymers (16)

As indicated in the previous study, a plastic sheet is subjected to severe strains and stresses during a deep drawing operation such as shown in Figure 42. The forces acting on the material in drawing are schematically illustrated in Figure 43 and a force equilibrium diagram is shown in Figure 44.

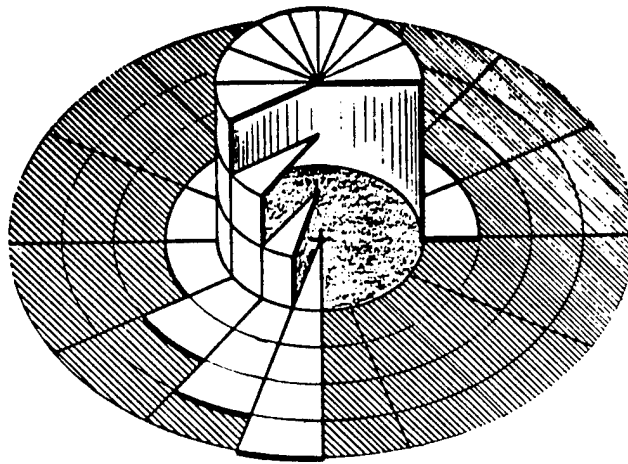

Figure 42. Step by step flow of plastic (9)

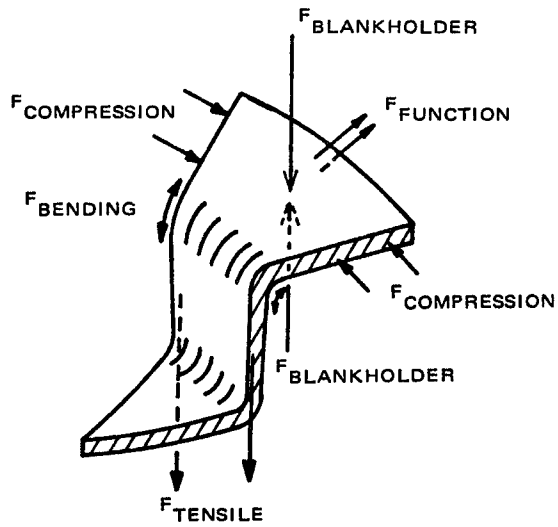

Figure 43. Forces in deep drawing (17)

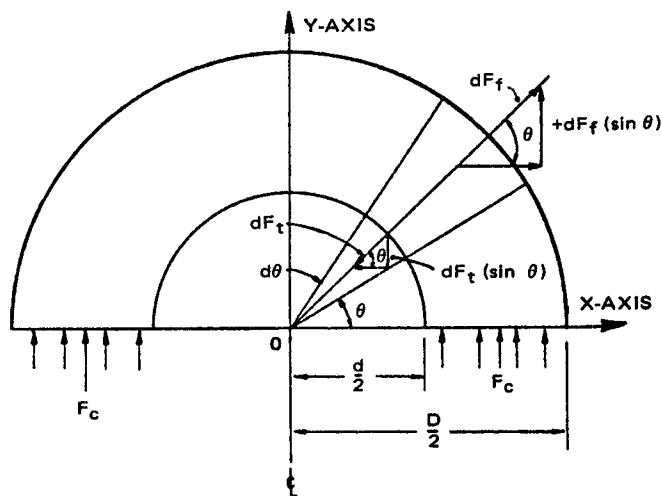

Figure 44. Force equilibrium diagram for one-half of the blank in x-y plane (18)

The material in the flange is drawn into the die under the tensile force (F_t) produced by the punch. This is opposed by the circumferential compressive force (F_c) and frictional force (F_f) as a result of the hold-down force of the drawpad and a bending force (F_b) at the die and punch radii. Therefore it can be expressed as: $F_t = F_c + F_f + F_b$.

The components of tensile, frictional, and compressive forces along the Y axis as well as the bending forces during the deep drawing process have been measured and calculated to develop a quantitative relationship between the depth of draw and the basic material properties of the plastic blanks (18). They are expressed in the following equations:

$$\text{tensile force: } S_t \cdot t \cdot \frac{d}{2} \int_0^\pi \sin \theta \cdot d\theta = d \cdot t \cdot S_t \quad (1)$$

$$\text{frictional force: } \frac{\mu \rho \cdot (D^2 - d^2)}{4} \int_0^\pi \sin \theta \cdot d\theta = \frac{\mu \rho}{2} (D^2 - d^2) \quad (2)$$

$$\text{compressive force: } S_c \cdot (D - d) t \quad (3)$$

$$\text{and bending forces: } K \cdot E \cdot d \cdot t^2 \quad (4)$$

where S_t = tensile stress on the blank

t = thickness of blank

μ = coefficient of friction

ρ = hold down pressure

S_c = compressive yield stress of the blank

D = diameter of the blank

d = diameter of the cup

K = constant (dimensions, in.^{-1})

E = tensile modulus of material

Combining equations 1-4 gives:

$$d \cdot t \cdot S_t = \frac{\mu \rho}{2} (D^2 - d^2) + S_c (D - d) t + KEt^2 \quad (5)$$

which after simplification reduces to:

$$S_t (\text{drawing}) = \mu \rho \frac{(D^2 - d^2)}{2dt} + S_c \left(\frac{D}{d} - 1 \right) + KEt \quad (6)$$

Here S_t , drawing, is the tensile stress in the corner of the cup bottom during drawing. Since a successful drawing requires that the material neither break nor yield under the combined action of the hold-down pad and the punch, the following condition is necessary for draw forming:

$$S_t < S_t^* \quad (7)$$

where S_t^* is either the tensile strength or the tensile yield stress of the blank.

The depth or severity of draw is expressed in terms of a limiting or maximum draw ratio which is:

$$\frac{\text{Blank diameter}}{\text{Punch diameter}} \quad \text{or} \quad \frac{D}{d}$$

This ratio represents the largest blank diameter that can be drawn to form a cup of a given diameter without fracturing, tearing or wrinkling. Generally, a material with a high limiting draw ratio is preferred to one with a lower limiting draw ratio because the former offers more flexibility in the choice of processing conditions and better economics due to fewer failures in the shaping step.

If equation (6) were used to plot the draw ratio D/d as a function of tensile and compressive stress S_c the plots would show that the draw ratio increases with increasing tensile and decreasing compressive stress.

Equation (6) can be simplified if the effects of material parameters and maximum draw ratio, D/d , are to be studied. The term KEt associated with the bending force is considered to be small compared with the effects of friction and compression. Also, the term $\frac{\mu\rho(D^2 - d^2)}{2dt}$ includes, with the exception of D , only processing parameters. These latter parameters must be constant in experiments conducted to study the effects of material parameters, E , S_t , S_c on the maximum draw ratio D/d . Consequently, the following relationship holds:

$$S_t^*/S_c = (D/d - 1) + C \quad (8)$$

where C is a constant dependent on the choice of experimental conditions. The error associated with the fact that C is not constant, but varies with D is considered insignificant because the variations of D are usually smaller than 20 percent and also

$$S_c (D/d - 1) > \frac{\mu\rho(D^2 - d^2)}{2dt} \quad (9)$$

Equations (7) and (8) represent the criteria regarding tensile and compressive stress of the blanks in drawing.

In addition to the above, tensile strain must also be considered. This is associated with the bending deformation occurring when the material is drawn over the edge of the die into the cavity. Therefore, the maximum tensile strain, ϵ_{\max} , in the blank due to the bending over an edge is expressed as:

$$\epsilon_{\max} = \frac{0.5t}{R_0 + 0.5t}$$

where R_0 = the radius of curvature of the die edge.

It can be inferred that the requirements on tensile strain vary depending on the shape of the part and the thickness of the blank. If a value of tensile strain which would be sufficient in most applications is considered then assuming a blank thickness of 0.1 inch and a radius of curvature of 0.1 inch, a maximum tensile strain of about 30 percent is obtained.

A great number of sheets were reportedly cold formed and it was found that the minimum requirement on elongation at break of 30 percent was a useful guideline for the screening of material along with the value of the ratio S_t/S_c (18).

A modified Swift cup test has been recommended for the experimental determination of the limiting draw ratio (19). In this test an empirical relationship is obtained between the maximum punch load and a measurement of the punch load at the failure of a blank whose outer rim is not free to flow. It is accomplished by drawing a blank into the shape of a cup. During drawing a constant clearance is maintained between the drawing and the die by a metal clearance ring. The clearance is about 5 percent greater than the thickness of the blank. A load cell, attached to the punch, records the punch load during the drawing process.

Blanks of various diameters are then drawn and the maximum punch load for each drawing ratio noted. A similar blank is then drawn without allowing the outer region to flow by removing the clearance ring so that failure (either necking or fracture) occurs. The punch load at failure is then noted.

An empirical curve relating the maximum punch load to the drawing ratio from the first drawing and the drawing ratio corresponding to the punch load at failure in the second drawing are extrapolated, as shown in Figure 45. This drawing ratio is the limiting drawing ratio.

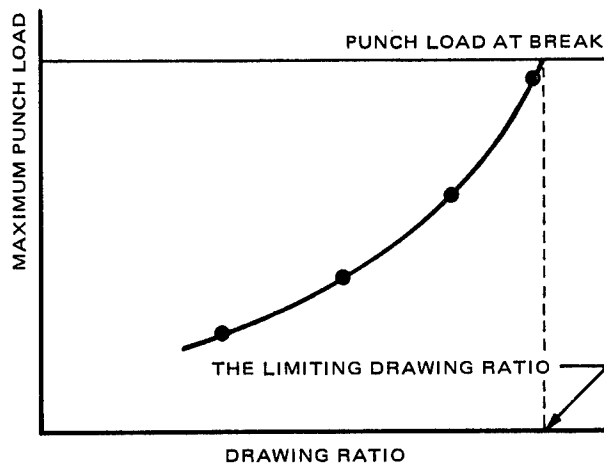

Figure 45. Determining the limiting drawing ratio (19)

It is important to note that limiting drawing ratios obtained this way may depend on tool design and on sheet thickness. In these tests, a radius of curvature of 0.2 inches for the punch and the die, a punch diameter of 1.360 inches and a die diameter of 1.50 inches gave reproducible results. The results were also independent of sheet thicknesses between 0.040 and 0.060 inches.

Since it is known that the maximum draw ratio of a material depends on the ratio of S_t^*/S_c , research was conducted on the effects of molecular orientation on the S_t^*/S_c ratio of the material. Typical operations which produce molecular orientation are: biaxial or uniaxial hot stretching at a temperature between the melting point (T_m) and the glass transition temperature (T_g) of the polymer - preferably between $T_m - 20^\circ\text{C}$ and $T_g + 40^\circ\text{C}$ for a crystalline and $+150^\circ\text{C}$ and $T_g + 10^\circ\text{C}$ for amorphous polymers; hot pressing between plates; and hot rolling between the nip of two driven rolls at the above temperatures. Depending on the polymer, these operations can also be carried out at ambient temperatures. Further, it must be pointed out that certain polymers can be treated by these methods with success below their glass transition temperature and below ambient temperatures. Examples of such polymers are polycarbonate and polyvinyl chloride. The degree of orientational anisotropy imparted by a given process is roughly in proportion to the degree of plastic deformation imparted by the selected process.

A significant improvement in S_t^*/S_c ratio was found through orientation by mechanically treating the sheet stock even when reduction in sheet thickness was as low as 5 percent. In most cases, a reduction in the thickness in the order of 30 percent produced marked increase in the value of S_t^*/S_c and the ability to draw. No significant additional advantage was found by more than a 60 percent reduction (17).

Typical values of S_t^* and S_c and the S_t^*/S_c ratio are listed in Table 4 for a variety of commercial sheets both as received and on sheet stock which was biaxially cold rolled to 30 percent reduction in thickness. The results show that cold rolling led to a marked improvement in the S_t^*/S_c and drawing ratios (17).

Table 4. Effect of Cold Rolling on S_t^*/S_c and $\frac{D}{d}$ Ratios (17)

Polymer Sheet	As Received			Cold Rolled to 30% Thickness Reduction	As Received	Cold Rolled to 30% Thickness Reduction
	S_t^* psi	S_c psi	S_t^*/S_c	S_t^*/S_c	Maximum Draw Ratio of Polymers $\frac{(D \text{ max})}{d}$	
Polycarbonate	8,700	12,500	.70	1.70	1.75	2.13
PVC	5,400	7,000	.77	1.12	1.75	2.0
Chlorinated PVC	8,250	15,000	.55	1.0	1.50	1.88
Polysulfone	10,200	13,900	.74	1.50	1.75	2.13
Phenoxy	10,000	18,000	.56	1.45	would not draw	2.0
P.P.O.	11,000	16,500	.67	1.40	1.75	2.13
A.B.S.	5,600	8,000	.70	1.05	1.63	1.88

In another study the drawability of biaxially cold-rolled polycarbonate, ABS and modified polyvinyl chloride was correlated with the material's anisotropic properties (20).

The drawability of a material can be improved if the force that the material surrounding the punch can withstand is increased in relation to the drawing force required to pull in the outer portion of the blank. Thus the fracture load can be increased without increasing the drawing force by increasing the load resistance of the material in its thickness direction relative to its load resistance in the plane of the blank. Therefore, an anisotropic material has better drawability than an isotropic one. However planar anisotropy as indicated by the difference in properties measured in the plane of the sheet is objectionable in deep drawing. Planar anisotropy results in the formation of ears in deep drawing (see Figure 46). The height of the ears depends on the magnitude of the difference in properties in various directions.

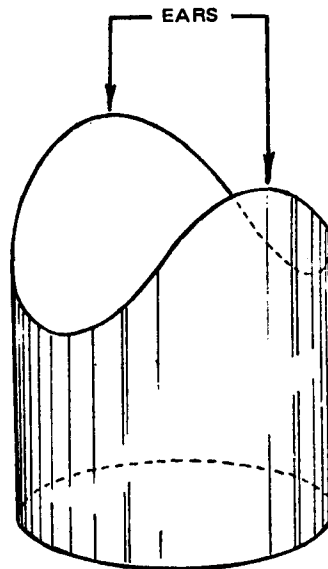

Figure 46. Earing in a drawn cup (19)

Normal anisotropy is usually more pronounced than planar anisotropy and is important in deep drawing as previously described. The parameters necessary to define the anisotropy of the sheet can be determined from the strain ratios measured in three directions in the sheet, at 0, 45 and 90 degrees to any reference axis. A material is isotropic if all the strain ratios are equal. Complete isotropy requires all strain ratios to be equal to unity.

The component of normal anisotropy is defined as

$$\bar{R} = \frac{1}{4} (R_0 + 2R_{45} + R_{90}) \quad (1)$$

The component of planar anisotropy is defined as

$$\Delta R = \frac{1}{2}(R_0 - 2R_{45} + R_{90}) \quad (2)$$

The criterion for yielding of a material with normal anisotropy and planar isotropy, under combined planar stresses is given by

$$\sigma_x^2 \left[1 + a^2 - a \left(\frac{2R}{R+1} \right) \right] = x^2, \quad a = \sigma_y / \sigma_x \quad (3)$$

where R = anisotropy ratio
 x = yield strength in the plane

This equation produces a group of yield ellipses as shown in Figure 47. Each ellipse corresponds to a given value of R . The effect of normal anisotropy is to extend or compress the major axis of the ellipse along OA.

Increasing the anisotropy ratio (R), increases the planar strength for a biaxial stress state with a stress ratio $a > 0$. The reverse is true for a stress ratio $a < 0$. But as seen in quadrants I and II, the effect of normal anisotropy is much more marked for $a > 0$ than for $a < 0$ (20).

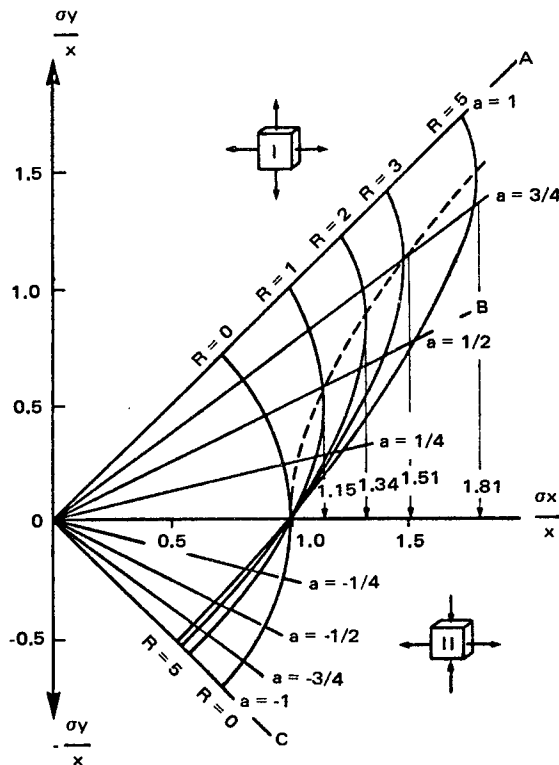

Figure 47. Yield locus for sheet material with anisotropy (20)

The material in the flange and in the region surrounding the punch profile radius deforms under different stress states. The flange has a radial tension and circumferential compression acting on it. For this region α is less than 0 and it corresponds to the lower quadrant in Figure 47. The region surrounding the punch face has biaxial tension on it and that corresponds roughly to $\alpha = 1/2$. So it corresponds to the upper quadrant in Figure 47. A successful draw depends on the mutual relation between the forces in these two regions. Figure 47 shows that by increasing R , the force required to deform the flange decreases, while the force carrying capacity of the material around the punch face is increased. This is how better drawability is obtained.

Tensile specimens were prepared at 0° , 45° and 90° to one of the rolling directions for polycarbonate, ABS and modified PVC sheets to measure normal and planar anisotropy. Two different roll reductions were considered for each material. The strain ratio R was determined by measuring the width and thickness change of the tensile specimens as a function of elongation.

The change in normal and planar anisotropy with elongation is shown in Figures 48 and 49 and Table 5. This change in anisotropy is the result of structure changes due to molecular orientation.

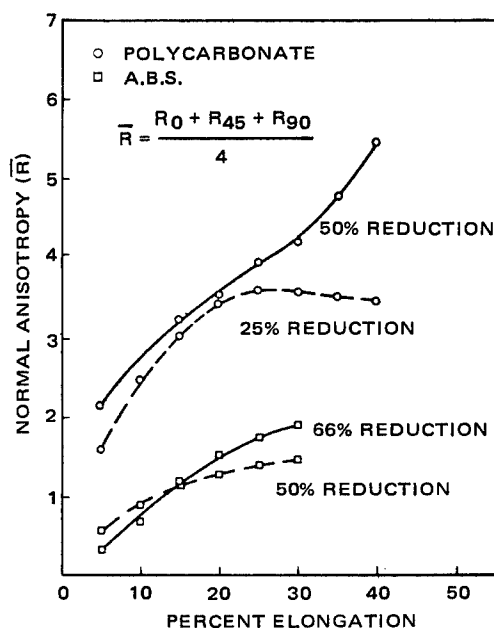

Figure 48. Normal anisotropy vs. percent elongation of tensile specimen for biaxially rolled polycarbonate and ABS polymers (20)

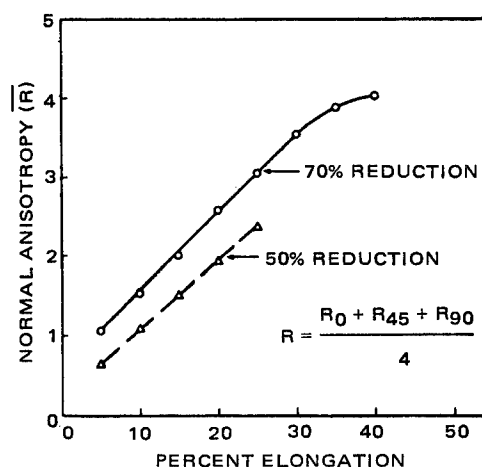

Figure 49. Normal anisotropy vs. percent elongation of tensile specimen for biaxially rolled PVC polymer (20)

Table 5. Values of Planar Anisotropy (ΔR) for Biaxially Rolled Polymers (20)

Material	Percent Elongation				
	5	10	20	30	40
Polycarbonate					
25% roll reduction ($t_o = .040''$, $t_f = .030''$)*	1.94	3.38	1.47	1.50	1.40
50% roll reduction ($t_o = .060''$, $t_f = .030''$)	0.83	1.00	0.62	0.66	0.85
ABS					
50% roll reduction ($t_o = .060''$, $t_f = .030''$)	0.40	0.25	0.13	0.10	--
66% roll reduction ($t_o = .120''$, $t_f = .040''$)	-0.01	0.12	0.43	0.56	--
PVC					
50% roll reduction ($t_o = .140''$, $t_f = .070''$)	-0.38	-0.18	-0.06	-0.12	-0.40
72% roll reduction ($t_o = .140''$, $t_f = .040''$)	0.18	0.28	0.23	--	--

* t_o = original sheet thickness

t_f = final sheet thickness after rolling

Polycarbonate sheets possess the greatest normal anisotropy having values greater than four above 25 percent elongation. The planar anisotropy values for the rolled polymers shown in Table 5 indicate that the polymer sheets are not isotropic in the plane of the sheet ($\Delta R = 0$ when the sheets possess planar isotropy).

Blanks of the three materials were drawn using the Swift cup test to determine the limiting draw ratio of the rolled material and to compare this with the strain ratios from their tensile experiments.

The results for the limiting draw ratios are shown in Table 6 for blanks used with and without a lubricant. As previously noted lubricants increase the drawability of a sheet. It was determined experimentally that the drawing force was reduced when the lubricant was used and thus a larger blank diameter can be drawn before fracture occurs. The limiting draw ratio for unlubricated sheets versus the roll reduction is given in Figure 50.

Table 6. Results on Limiting Draw Ratio (20)

Material	Friction Condition	Limiting Draw Ratio	Normal Anisotropy	
			25% Elongation	30% Elongation
Unrolled Lexan	Dry	2.00		
	Lubricated*	2.16		
25 percent biaxially rolled Lexan	Dry	2.60	3.62	3.59
50 percent biaxially rolled Lexan	Dry	3.10	3.98	4.23
	Lubricated	3.20		
Unrolled A.B.S.	Dry	1.89		
	Lubricated	2.03		
50 percent biaxially rolled A.B.S.	Dry	2.25	1.41	1.47
	Lubricated	2.25		
66 percent biaxially rolled A.B.S.	Dry	2.29	1.75	1.91
Unrolled P.V.C.	Dry	1.90		
	Lubricated	2.11		
72 percent biaxially rolled P.V.C.	Dry	2.85	3.05	3.58
	Lubricated	3.10		
50 percent biaxially rolled P.V.C.	Dry	2.61	2.37	--

* Lubricant - Bruko D-493 (Bruce Products Corp., Howell, Mich.), 50% aqueous solution

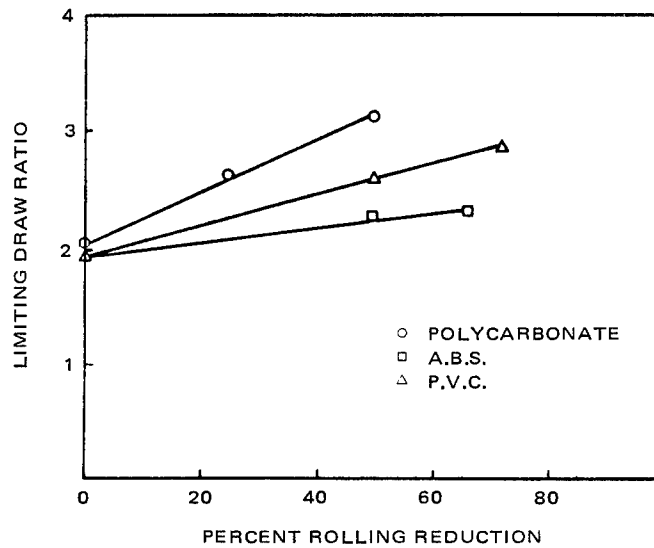

Figure 50. Limiting draw ratio vs. biaxial roll reduction (20)

There is an obvious increase in the limiting draw ratios with roll reduction and the polycarbonate materials show the greatest increase. Figure 51 plots the limiting draw ratios vs. the normal anisotropy and a definite relationship can be established. The best agreement appears to occur for values of normal anisotropy determined at 30 percent elongation which is reasonable based upon anticipated deformations in the drawn sheets. This confirmation between normal anisotropy and limiting draw ratios agrees with results for metals where the same relationship has been found. Thus, this serves to explain why biaxially rolled sheets produce better drawability. It should also be noted that the drawability of the rolled polycarbonates is greater than that of the best metals. For biaxially rolled polymer sheets (thickness reductions greater than 25 percent) necking and stress whitening can be eliminated. Thus, there is no local region of thinning in formed blanks. As larger blanks are formed, the forming load increases and at the blank size corresponding to the limiting case the forming load is high enough to cause fracture of the material close to the punch radius.

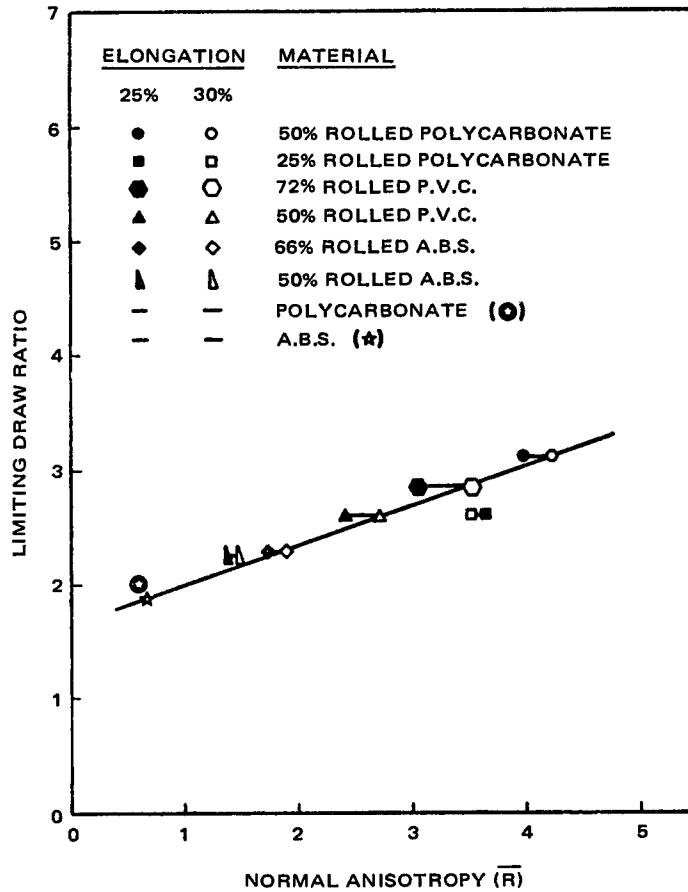

Figure 51. Limiting draw ratio vs. normal anisotropy (20)

EFFECT OF SOLID-PHASE FORMING ON PROPERTIES

Over and above the potential economic advantages due to the short cycle time and simple equipment, the ability to easily fabricate very high molecular weight or very high melting plastics, there is an improvement in certain engineering properties. This improvement in engineering properties has been the subject of several studies some of which are summarized below. These improvements have been attributed to molecular orientation brought about by the solid-phase forming techniques.

In order to study the effects of material flow on engineering properties, polypropylene billets of constant diameter but with different thicknesses were forged under constant conditions to produce 200 mm diameter wheels in a range of web thicknesses (5).

To eliminate the effect of surface cooling, properties were evaluated from a 4 mm disk machined from the center plane of each wheel. Two sizes of specimens, 126 and 60 mm in length, were cut from the series of disks as shown in Figure 52.

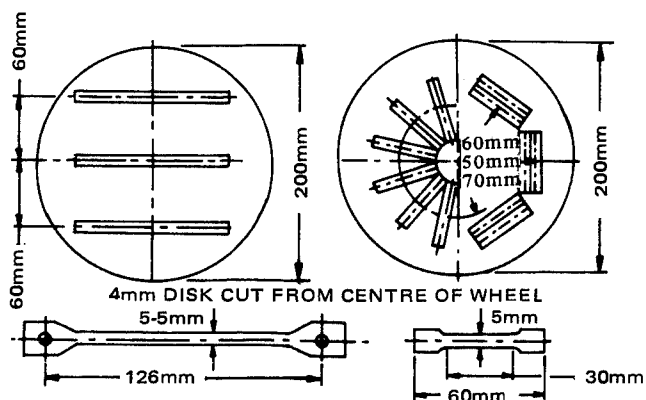

Figure 52. Specimen positions and dimensions (5)

The 60 mm specimens were taken both radially and transversely relative to the direction of flow. The large specimens were taken only in the transverse direction. The properties of both sizes of specimens were determined by tensile tests and tensile creep tests carried out at 20°C and 65 percent relative humidity.

The stress-strain curves for the 60 mm specimens are shown in Figure 53. The stress values have been expressed in terms of the original area and each curve is the mean of the results from each wheel. The effect

of material displacement becomes apparent when the curves for radial and transverse samples are compared with that for the unforged material.

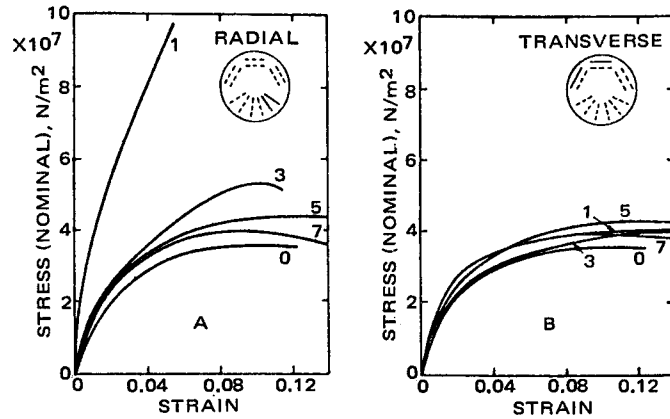

Figure 53. Tensile tests on forged polypropylene 60 mm specimens at 20 mm/min (5)

- (a) Specimens cut in radial direction
 (b) Specimens cut in transverse direction

<u>Curve No</u>	<u>Displ, %</u>	<u>Curve No</u>	<u>Displ, %</u>
0	0	5	41
1	58	7	26
3	50		

Comparison of these values indicates a fairly substantial increase in both strength and stiffness in the radial direction but only marginal increases in the transverse values. Also, the type of radial tensile failure changes from ductile to semi-brittle as the displacement factor increases.

$$\text{displacement factor \%} = (t_0 - t_1) / t_0 \times 100$$

where t_0 = original billet thickness

t_1 = final web thickness

The results of both sizes of transverse specimens from all locations as given in Table 7 indicate that there is no significant variation in the transverse properties across a disk.

Table 7. Transverse Properties (5)

NO	t_0	t_1	Displacement Factor	Average Transverse Stress
	mm	mm	%	N/m ²
<i>60 mm test piece</i>				
1	15.0	6.3	58	4.03×10^7
3	18.0	9.1	50	4.01×10^7
5	22.4	13.1	41	4.23×10^7
7	35.5	26.2	26	3.97×10^7
0	---	---	0	3.62×10^7
<i>126 mm test piece</i>				
9	14.9	5.1	63	4.15×10^7
10	16.6	7.6	54	4.11×10^7
11	19.2	10.0	47	3.95×10^7
12	21.6	12.5	42	3.95×10^7
13	24.2	15.1	37	3.88×10^7
14	26.5	17.6	34	3.75×10^7
15	38.4	32.0	21	3.72×10^7
16	---	---	0	3.62×10^7

The maximum stress values are plotted against displacement factors in Figure 54. Below the 40 percent displacement factor there is very little change in tensile properties, but above this value the maximum radial stress rises sharply.

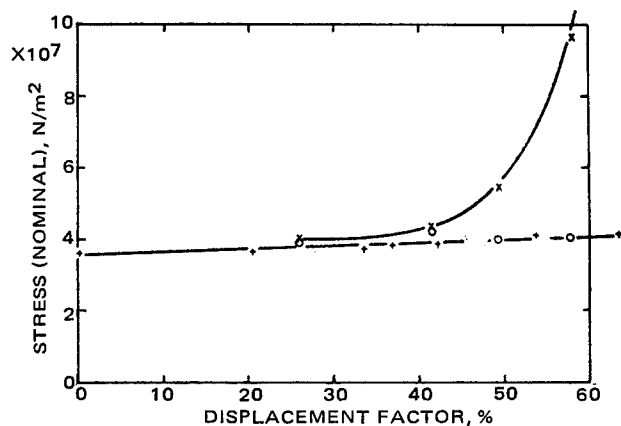

Figure 54. Effect of material flow on tensile strength of forged polypropylene (5)

- x 60 mm radial
- o 60 mm transverse
- + 126 mm transverse

The creep data are presented in two forms, isochronous stress-strain curves and as strain-log plots in Figures 55 and 56. In an isochronous stress-strain relationship, a section is taken at constant time across the 3-dimensional stress-strain-time function. This procedure involved repeated loading of each specimen at successively higher stresses to a predetermined time when the strain was observed. The specimen was unloaded and allowed to recover for four times the loading time before proceeding to the next stress level. Corrections were made for any residual strain at the end of the recovery period.

The 100 second isochronous stress-strain curves plotted for the 60 mm radial and transverse specimens cut from wheels of known displacement are shown in Figure 55.

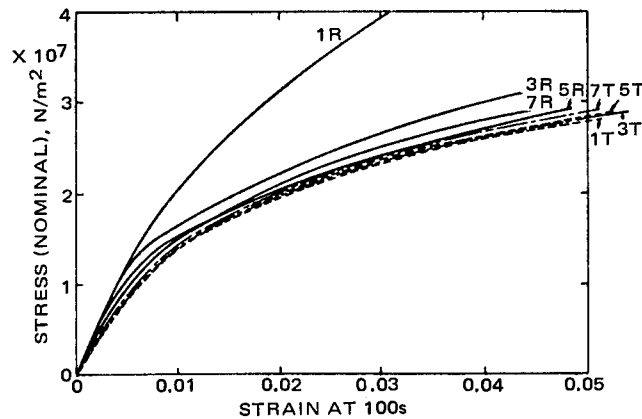

Figure 55. Radial and transverse 100 s isochronous stress/strain curves for forged polypropylene (5)

<u>Curve No</u>	<u>Displ, %</u>	<u>Curve No</u>	<u>Displ, %</u>
0	0	5	41
1	58	7	26
3	50		

The radial specimens are all stiffer than the transverse specimens up to the 0.01 strain level. The transverse results are similar to those of the unforged compression molded material. This increased stiffness of the radial specimens is related to the displacement factor in much the same way as that of radial tensile specimens mentioned previously. Above the 0.01 strain level an interesting pattern emerges when the radial and transverse curves from the same disk are compared. There is considerable difference in slope between numbers 1R and 1T for a displacement of 58 percent. As the displacement factor decreases, this divergence diminishes, and below a 45 percent displacement the slopes are practically identical.

Figures 54 and 55 indicate that up to a displacement of between 40 percent and 45 percent there is a marginal increase in the tensile and tensile-creep strength in both directions. Above the 45 percent level there is an improvement in properties in the radial direction at the expense of the properties in the transverse direction.

Figure 56 compares the creep curves for the 126 mm transverse specimens at a 58 percent displacement factor with unforged specimens. The crossover points due to the higher creep rate of the transverse specimens can be seen.

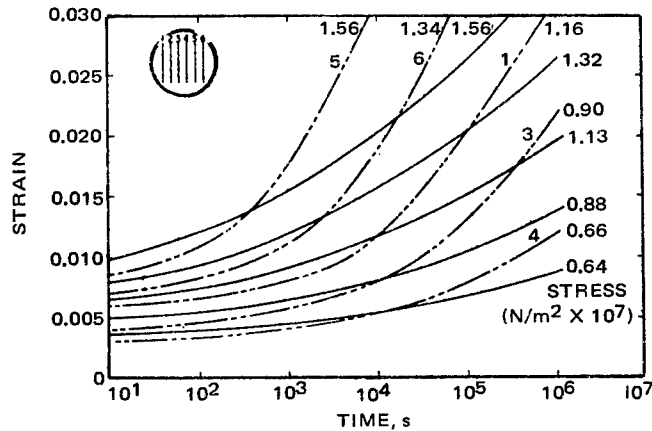

Figure 56. Creep curves for forged polypropylene at a displacement factor of 58 percent.

126 mm specimens cut in transverse direction and compared with unforged compression-moulded sheet (5)
 - - - - - transverse; ————— comp.-moulded

For short periods the creep resistance at all stress levels of the transverse specimens is greater than that of the unforged specimens. Then crossover occurs and the creep strain of the forged material continues at a faster rate than that of the unforged. The crossover decreases as the stress level is increased (0.64×10^7 N/m² at 10^4 s and 1.56×10^7 N/m² at 150 s). Two specimens were tested to 10^7 s at 0.65×10^7 N/m² and at 0.90×10^7 N/m² but no decrease in the creep rate was observed.

From the above work it can be concluded that the maximum tensile strength of forged polypropylene in the radial direction increases sharply with the displacements above 40 percent to a maximum of over twice the strength of the unforged material. In the transverse direction there is a very slight increase in strength roughly proportional to the displacement ratio. The stiffness follows a similar trend. The creep tests suggest that the improved stiffness in the radial direction is not maintained over long periods of continuous loading.

Additional comparisons of the properties of forged and unforged polypropylene are presented in a report dealing with the feasibility of using cold forming techniques for the production of sabots. Tests were conducted on rod stock forged at 100 tons pressure which was held for three minutes. A summary of results is given in Table 8 below.

Table 8. Mechanical Properties of Polypropylene, Forged and Unforged (4)

Unforged Polypropylene		Forged Polypropylene	
Room Temperature			
Tensile, psi	Elongation (% in 2")	Tensile, psi	Elongation (% in 2")
3404	100.0	3866	93.8
3360	87.5	3804	100.0
3386	100.0	3851	75.0
3412	200.0	3944	87.5
3464	200.0	4006	87.5
avg 3405	avg 137.5	avg 3894	avg 88.8
Oven Aged at 145°F for 1 hour			
2206	350+	2025	350+
2162	350+	2195	350+
2179	350+	2280	350+
2222	350+	2324	350+
2186	350+	2256	350+
avg 2191	avg 350+	avg 2216	avg 350+
Aged at -65°F for 1 hour			
10,000	1.6	8789	3.1
10,344	1.6	9203	3.1
9,800	4.7	8557	4.7
9,463	3.2	8619	3.1
9,294	0	avg 8792	avg 3.5
avg 9,780	avg 2.2		
Hardness (Rockwell R)			
Sample 1.	90	Sample 1.	96
" 2.	91	" 2.	95
" 3.	90	" 3.	99
" 4.	91	" 4.	96
" 5.	91	" 5.	96
" 6.	91	" 6.	95
" 7.	90		
" 8.	91		

Table 8. (continued)

Unforged Polypropylene	Forged Polypropylene
------------------------	----------------------

Heat Distortion Temperature at 264 psi

Sample 1. 60°C
 " 2. 62°C
 " 3. 60°C

Sample 1. 61°C
 " 2. 63°C
 " 3. 61°C

Low Temperature Brittleness

Temp	Tested	Passed	Cracked	Broken	Temp	Tested	Passed	Cracked	Broken
- 20	5	0	0	5	+30	5	0	2	3
- 10	5	0	0	5					
- 0	5	0	0	5					
+ 10	5	0	0	5					
+ 20	5	1	4	0					
+ 20	10	8	2	0					
+ 30	10	10	0	0					

Impact Test

Temp	Ft Lbs	Temp	Ft Lbs
70°F	2.40	70°F	1.60
70°F	2.40	70°F	1.68
+ 145°F	5.64	+ 145°F	4.88
+ 145°F	5.64	+ 145°F	4.80
-65°F	0.40	-65°F	0.16
-65°F	0.32	-65°F	0.24

From this data the following can be determined:

- The average tensile strength of the forged samples was greater than the unforged samples at ambient and 145°F but lower at -65°F. Likewise, elongation of the forged samples decreased at ambient and 145°F but increased at -65°F over the unforged material.
- The heat distortion temperature of forged and unforged samples was practically the same. Rockwell hardness remained basically unchanged also.
- The unforged samples had higher impact strength at all temperatures and superior low temperature brittleness, 10°F versus 30°F.

Density measurements were made on small cubes machined from the forged blocks. The results, 0.899 to 0.900 compared favorably with the literature value for the same material which was 0.895 to 0.905.

The faces of two forged polypropylene blocks were planed to flatnesses within two thousandths of an inch. The blocks were then aged two days, one in an air circulating oven at 150°F and the other in a humidity cabinet at 100 percent R.H. Final measurements showed both were flat to within two thousandths of an inch.

Lastly, to determine relative reproducibility of the forged sabot blocks, eight preforms were forged. After forging, their faces were planed at a 90° angle to each other, assembled into two sets of four each, and measured. Of the sixteen measurements made on each set, six dimensions were within six thousandths of an inch from each other, four varied from 18 to 23 thousandths of an inch and six were identical. These were within the dimensional tolerances of the drawing, and reproducibility was satisfactory.

The cold rolling of plastic sheet has been the subject of several studies to determine how properties change when the material is subjected to room temperature deformations (21, 22).

Stress-strain properties have been measured for both uniaxially and biaxially rolled sheet with up to 60 percent reductions. The biaxially rolled sheets were made by simply alternating the sheet direction 90°, for every pass through the rolling mill. The properties were measured both parallel and transverse to the rolling direction and are depicted in Figures 57 through 65.

This data shows that uniaxial cold rolling increases tensile strength approximately 100 percent at maximum reductions in the rolling direction. The tensile strength in the transverse direction decreases very slightly, but its ultimate elongation is greater than the virgin material. This indicates that the transverse properties in a rolled sheet are not sacrificed as they increase in the rolled direction.

The increase in tensile strength for cross-rolled material is approximately 50 percent at maximum reductions in both directions. This occurs because approximately one-half the orientation occurs in each direction for the same roll reduction.

Yielding or necking decrease as thickness reduction increases in unidirectionally rolled samples in the rolled direction. In fact, the yield point is absent at the maximum reductions. Also, stress whitening is eliminated at the higher reductions (usually 40 percent or more) in the rubber modified polymers such as ABS (21, 22). This is especially beneficial in deep drawing.

The stress-elongation curves for unidirectionally rolled materials tested in the roll direction rise more steeply than the virgin material indicating increases in the modulus of elasticity. For example, the initial modulus of virgin polycarbonate was 3.43×10^5 psi and 4.5×10^5 psi after a 50 percent cold rolled reduction (22). The authors have speculated that the contradictory curves shown for ABS may have been the result of surface flaws which caused the premature break.

The stress elongation curves for uniaxially rolled samples tested at 90° to the rolling direction indicate that there is a reduction in yield strength with roll reduction.

Stress-strain curves for cross-rolled polymers show that the elongation-to-fracture is greater than the unidirectionally rolled specimens tested in the rolled direction. Yield points are observed beyond 40 percent reductions. However, this amounts to a 20 percent reduction in one direction which was not sufficient to inhibit yielding. The tensile strength also increases with increasing reductions in cross-rolling.

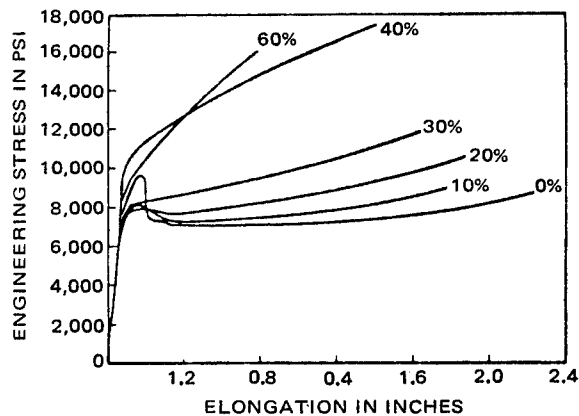

Figure 57. Stress-elongation curves for unidirectionally rolled polycarbonate (Lexan) tested in the rolling direction (21)

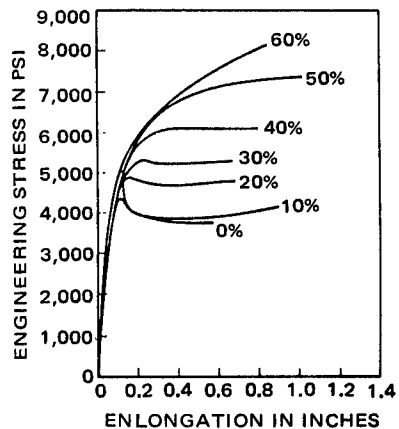

Figure 60. Stress-elongation curves for unidirectionally rolled ABS polymer (Cyclocac MS) tested in the rolling direction (21)

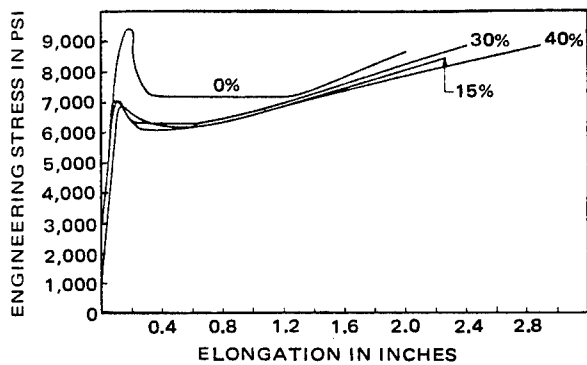

Figure 58. Stress-elongation curves for unidirectionally rolled polycarbonate polymers tested at 90° to the rolling direction (21)

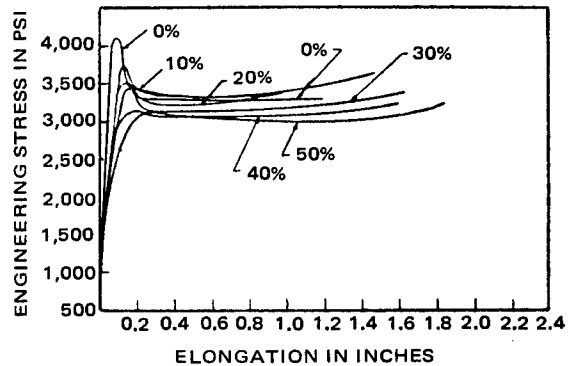

Figure 61. Stress-elongation curves for uniaxially rolled ABS plastic (Cyclocac MS) tested at 90° to the roll direction (22)

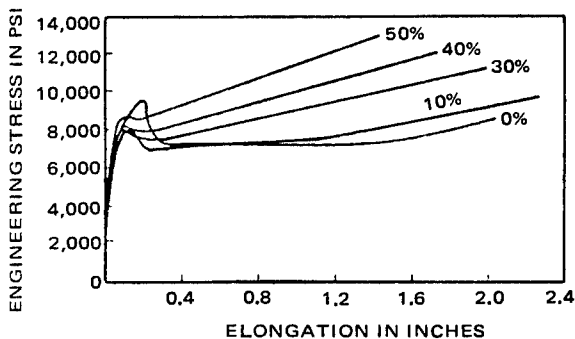

Figure 59. Stress-elongation curves for cross rolled polycarbonate (Lexan) tested in one of the roll directions (21)

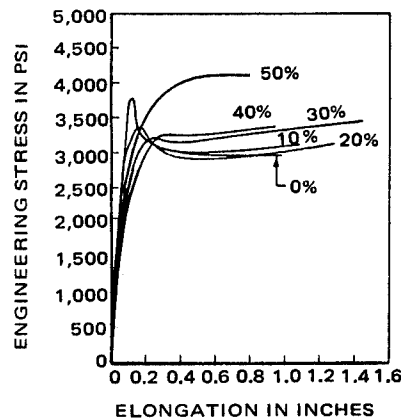

Figure 62. Stress-elongation curves for cross rolled ABS polymer (Cyclocac MS) tested in one of the rolling directions (21)

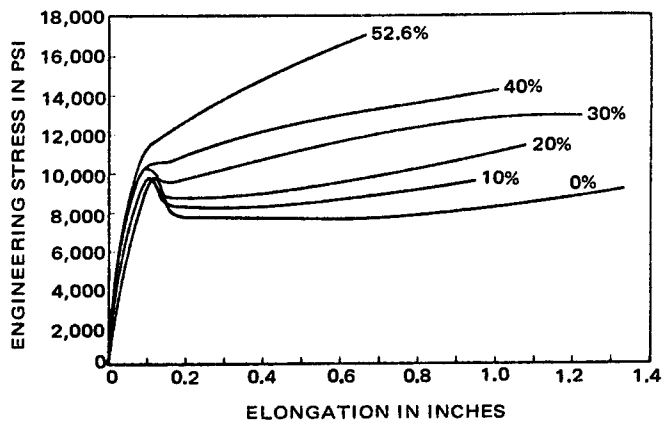

Figure 63. Stress-elongation curves for unidirectionally rolled polyphenylene oxide tested in the rolling direction (21)

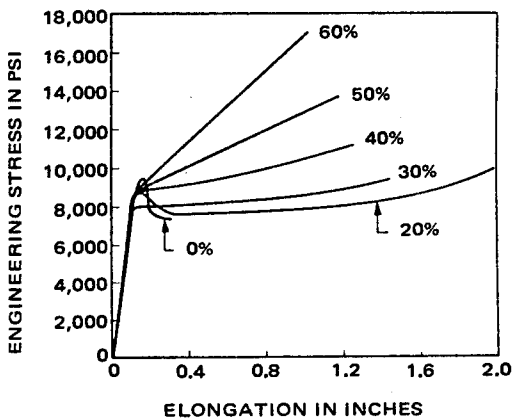

Figure 64. Stress-elongation curves for unidirectionally rolled polysulfone tested in the rolling direction (21)

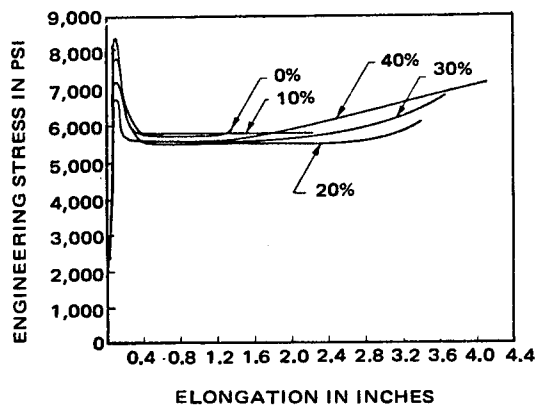

Figure 65. Stress-elongation curves for unidirectionally rolled high-impact PVC tested at 90° to the rolling direction (21)

The results of hardness measurements are shown in Figure 66. The hardness values decrease with reductions up to about 20 percent and then increase again with further reductions until they attain their original value.

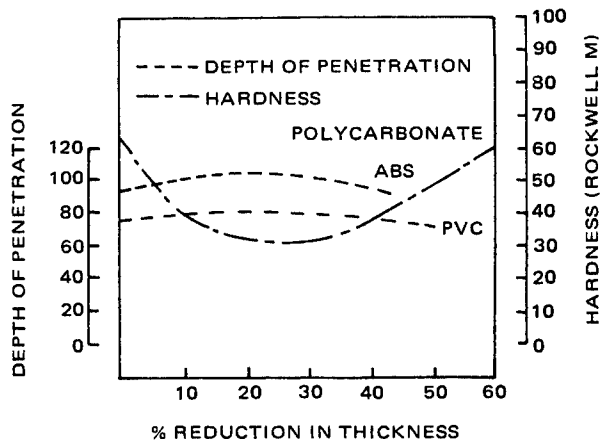

Figure 66. Hardness comparisons for rolled polymers (21)

Impact testing was accomplished edgewise in accordance with ASTM D256-56 at 70°F for polycarbonate. As shown in Figure 67 the maximum impact strength occurred at approximately five percent roll reduction and decreases sharply after about 30 percent reduction. As would be expected it is tougher in the transverse than in the rolled direction. The authors state that this enhancement of impact strength is not related to the thickness transition known to exist at .180 inches in polycarbonate but is the result of the rolling process.

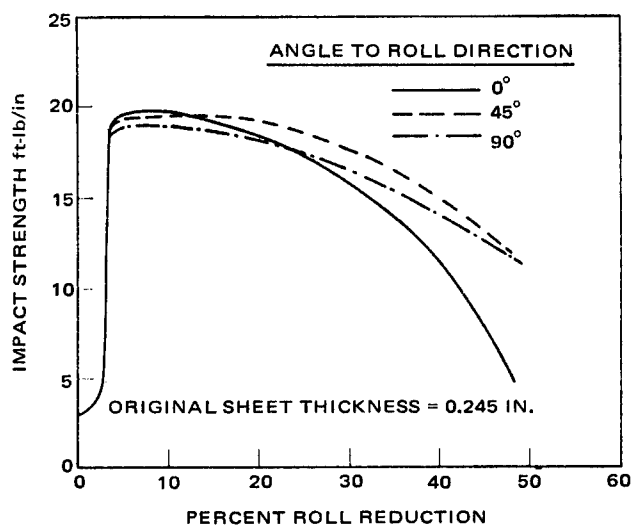

Figure 67. Variation of Izod impact strength with percent unidirectional roll reduction for polycarbonate (original sheet thickness = 0.245 inches) (21)

Density of cold-rolled samples was measured in a density gradient column and the results in Table 9 show an increase for all samples. The large increase for polyphenylene oxide and polysulfone was attributed to void in the samples.

Table 9. Density Change Due to Rolling (21)

Plastic	% Reduction of Thickness	Density in g/cc	% Increase in Density
Polycarbonate (Lexan)	0%	1.198	----
	50%	1.201	0.251%
ABS (Cycloc MS)	0%	1.084	----
	40%	1.0845	0.0461%
Polysulfone	0%	1.230	----
	60%	1.241	0.894%
Polyphenylene Oxide	0%	1.063	----
	44.8%	1.079	1.505%
Noryl	0%	1.121	----
	50%	1.124	0.26%

The dimensional stability of thermoplastic parts improves with increased forming temperature. For example, a polypropylene part formed at room temperature will be suitable for use at 150°F but not at 200°F. By preheating the billets thermal stability can be increased to 220°F. With optimum tool and billet temperatures stability up to 250°F to 270°F can be achieved. Dimensional stability here means part dimensions will be within 1 percent after 24 hours at the test temperature (2).

Cold-rolled thermoplastics will recover their original dimensions if heated to their glass transition temperature. As the temperature reaches the glass transition temperature the thermal agitation of the molecules overcomes the Van der Waal's forces, which lock in the orientation and the chains resume their original random conformation. Figure 68 shows the thermal recovery of polysulfone at 395°F for various cold-rolled reductions.

Another study of this well known "memory" phenomenon of cold formed amorphous polymers has been made to determine the ultimate service temperatures for a cold formed article (23). The study was based on an investigation of strain recovery behavior. Examined were the strain recovery rates for cold-rolled polycarbonate between 100° and 147°C ($T_g \approx 150^\circ\text{C}$) over 4.6 decades in time. Three types of samples were studied: uniaxially rolled to 25 and 50 percent reduction in thickness and biaxially rolled to 50 percent reduction in thickness.

The strain recovery data were found to superimpose for the three different degrees of deformation. Therefore the strain recovery behavior was considered to be independent of strain. This suggested that nonlinearity in the polymer results from large stresses (or the volume dilation accompanying these stresses) and not from large strains.

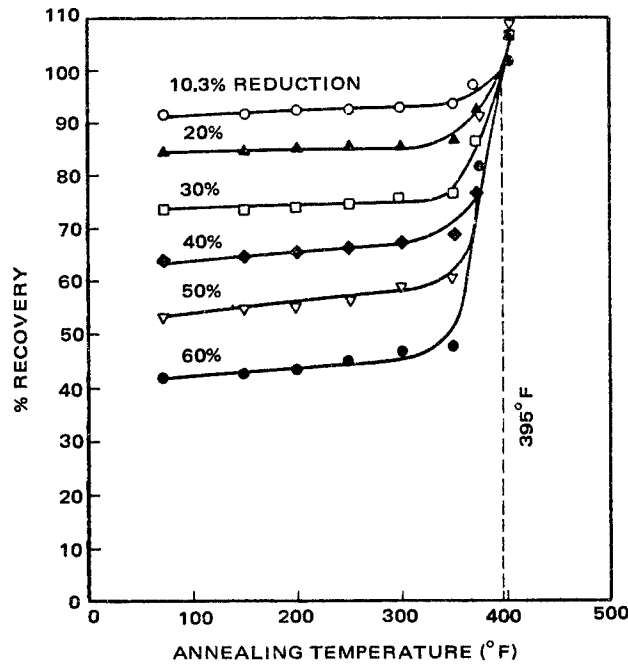

Figure 68. Percent recovery of thickness for unidirectionally rolled polysulfone sheets annealed for 15 minutes at various temperatures (21)

Analysis of the strain recovery data over a broad time scale indicated that recovery did not vary linearly with time. Therefore strain recovery could not be described by a single constant and a "strain recovery spectrum" $U(\tau)$ was required. An investigation was then made to determine if the "strain recovery spectrum" $U(\tau)$ which was believed to be analogous to the "stress relaxation spectrum" $H(\tau)$ employed in the linear viscoelasticity theory was related in some manner. Therefore the strain recovery following cold forming would be analogous to the creep recovery for a continuous spectrum where $W(\tau)$ or $U(\tau)$ is a distribution factor related to the "retardation spectrum" $L(\tau)$.

The strain-recovery isotherms for the uniaxially and biaxially rolled polycarbonate at 140°C were shifted horizontally along the log time (t) axis to produce the master curves shown in Figure 69. The stress-relaxation data shown were obtained on annealed, unrolled sheet between 20 to 170°C over 3.3 decades in time. As can be seen, the stress relaxation master curve is very similar to the strain master curve. The stress-relaxation modulus $E(t)$ in Figure 69 was divided by $E(1 \text{ min})$ at 20°C, 2.19×10^{10} dynes/cm² to give a dimensionless reduced modulus which is comparable to the reduced length and thickness (23). The temperature dependence of the shift factors, $\log(a_T)$ required to achieve the superposition is given in Figure 70.

The fact that the reduced master curves are slightly different in Figure 69 - the length appears to contract more rapidly than the thickness expands - indicates a consistent and systematic experimental error. In the transition region (Figure 70), strain recovery (thickness) exhibits a slightly sharper transition than stress relaxation; the apparently broad transition displayed by the length recovery is also believed to be experimental error (23).

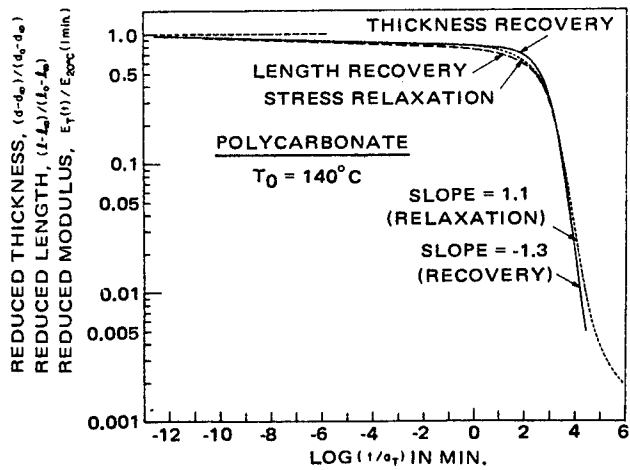

Figure 69. Comparison of reduced master curves for polycarbonate at 140°C: strain recovery and stress-relaxation (23)

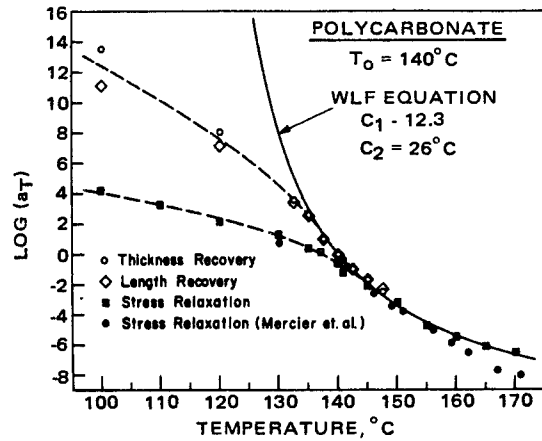

Figure 70. Comparison of time-temperature superposition shift-factors obtained from strain recovery and stress-relaxation (23)

The shift in strain recovery spectrum $U(\tau)$ as a function of temperature and the WLF shift factor were similar to those obtained from other viscoelastic measurements on polycarbonate. In the glassy region (below $\sim 150^\circ\text{C}$) a correction was applied for differences in stresses (see reference 37). Figure 70 compares the time-temperature shift factors obtained from strain recovery to stress relaxation.

From the recovery master curves in Figure 69, the strain recovery spectra, $U(\tau)$ or $W(\tau)$ were calculated using the following equation:

$$U(\tau) = -X X' [1 - X' - (d \log X') / (d \log t)] \quad t = 2 \tau$$

- where
- $X = (1 - 1_\infty) / (1_0 - 1_\infty)$
 - 1 = particular linear dimension
 - 1_∞ = length prior to cold forming
 - 1_0 = length at time (T) equal to 0
 - $X' = (d \log X) / (d \log t)$
 - d = particular thickness dimension
 - t = time

The strain recovery spectrum, $U(\tau)$ and the relaxation spectrum, $H(\tau)$ are shown in Figure 71 and are nearly identical.

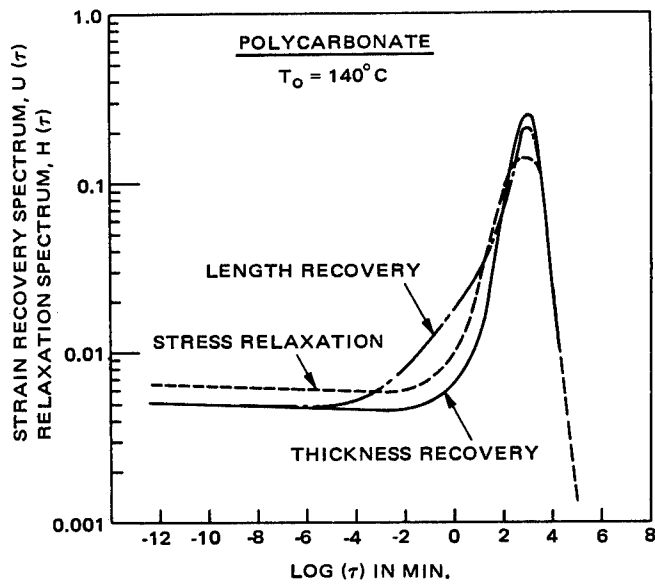

Figure 71. Comparison of stress-relaxation spectrum and strain recovery spectra for polycarbonate at 140°C (calculated from master curves in Figure 69) (23)

It was therefore concluded that $U(\tau) \approx H(\tau)$ and $W(\tau) \approx L(\tau)$.

Since the relaxation spectrum $H(\tau)$ or retardation spectrum $L(\tau)$ and the WLF relationship are known for many polymers, a complete strain recovery behavior of any cold-formed amorphous polymer can be estimated at any temperature from a general knowledge of the viscoelastic response at small strains using one of the following equations:

$$(\ell - \ell_{\infty}) / (\ell_0 - \ell_{\infty}) = \int_{-\infty}^{\infty} U(\tau) \exp(-t/\tau) d \ln \tau$$

or

$$(\ell_0 - \ell) / (\ell_0 - \ell_{\infty}) = \int_{-\infty}^{\infty} W(\tau) [1 - \exp(-t/\tau)] d \ln \tau$$

It was also noted that the $H(\tau)$ and $L(\tau)$ spectra tend to be similar for most polymers and when experimental data are not readily available, the spectrums can be approximated from a knowledge of similar polymer systems (23).

EQUIPMENT REQUIREMENTS

The basic equipment requirements for solid-phase forming are: means of producing billets or blanks, oven for preheating the blanks, molds, forming press and transfer and handling equipment. Like other methods of converting thermoplastic resins, there are many variations in each step according to the specific part requirements and quantity desired. Basically, there are two types of solid-phase forming systems, integrated and flexible. In an integrated system all steps from the preparation of the billet to removal from the press are automated and continuous. An example of such a system is shown in Figure 72.

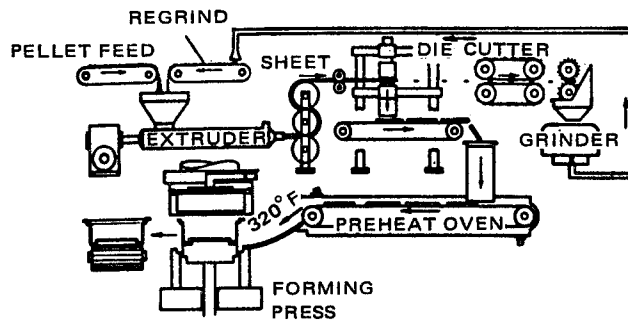

Figure 72. Process flow sequence typical of most solid-phase forming processes (10)

A flexible system employs a cooled stored billet with varying degrees of automation. The following describes equipment and tooling used in each of the major production steps:

BILLET OR BLANK PRODUCTION

There are many ways in which billets or blanks may be obtained. The method selected has a decided influence on the material cost which is the primary factor in the overall part cost.

Blanks can be formed from sheet material by blanking, cut from rod or even molded. Billets can be cut from rod or slab stock, molded, cast in single or multiple dies or extruded from pellets or powder. Extruding billets and sheet in an integrated system has an economical advantage. It can be completely automated and computerized. Sheet scrap or off-weight billets can be reground and reprocessed by mixing with virgin material. It can also contain a feedback system to correct extrusion conditions when the number of off-weight billets becomes excessive. Equipment requirements for molding, extruding or casting billets are melt processing techniques and therefore will not be covered here. Excellent descriptive articles of these processes can be found in the 1970-71 Modern Plastics Encyclopedia.

Plastic blanking is performed with material supplied in coil or strip. In the selection of a press and die, the following should be considered:

A long cutting stroke is required due to the shear characteristics of plastics. The ram speed should be as high as possible. Any tendency to slow down during cutting will result in an increase in shear forces and lateral flow of material. This lateral movement will cause an increase in the concaved shear edge of the blank. Excessive wear in a press ram will produce a blank with a stepped shear edge.

It is also important to have a press with very good ram alignment since dies for shearing plastics require a very close punch-to-die clearance. This clearance becomes even more critical with thinner materials. For example, a 1/2 mil clearance per side between punch and die is recommended for shearing 0.010 to 0.015 inch acrylonitrile-butadiene-styrene (ABS). If the clearance is too large the plastic will break, tear or flake.

Blanking can be accomplished on three types of dies: progressive, compound and steel rule. An accurate press feed is mandatory in high speed automatic blanking with a progressive die. Feeding is not as critical with compound dies, but faster ram action is required for cleaner sheared edges which make ejection easier. High speed blanking with steel-rule dies requires a positive stop either on the press or in the die so that the cut can be made against a hardened steel plate. Over-travel of the ram will result in the cutting edge of the blank being rolled over.

HEATING EQUIPMENT

The heating system is very critical in solid-phase forming. The equipment selected must be capable of heating the billet or blank uniformly from core to surface as well as long the surface to approximately 15 degrees below the melt temperature. Since plastics are a thermal insulating material this uniform heating becomes increasingly difficult with thicker billets.

Various methods of heating have been used successfully depending on the material and sheet or billet thickness required. Direct contact heating with platen heaters has been used successfully with polypropylene. This heater consists of Teflon coated aluminum platens which are heated electrically or with hot oil via passages which are machined into the aluminum. For example, a residence time of about 2 minutes for 100 mil sheet; 3 minutes for 125 mil; 5 minutes for 150 mil; and about 30 minutes for 500 mil stock has been reported (10).

Liquid bath heating has also been demonstrated to be satisfactory. However, the choice of the proper liquid becomes quite important, as well as providing some means to get rid of the few drops of liquid which adhere to the plastic when it is removed from the bath. For example, glycerine does not wet polypropylene, therefore it can be easily removed by shaking or wiping. The automation of a liquid heating system is quite simple, in that the use of conveying baskets can be used to carry billets into and out of the heating bath.

Infrared heaters have been used successfully in many commercial applications. The best results have been reported with a pulse heating technique using a high density tungsten/quartz heat source. While the problem of high surface temperature can occur, depending on the material's thickness and color, it has been found to be excellent for thin sheets and billets up to about 200 mils. Above this level edge and surface melting can occur.

The use of radio frequency heating is limited by the type of plastic used since some plastics are not susceptible to radio frequency current. Air circulating ovens have been used successfully but it requires more time and is significantly affected by air velocity.

PRESS EQUIPMENT

Three types of presses may be used in solid-phase forming. They are mechanical, hydraulic and rotary presses.

Mechanical Presses - Stamping, drawing, coining, blanking, and forging can be accomplished by many types of standard metalworking mechanical presses. The advantages inherent in the mechanical press are its relatively low initial cost and its high rate production capacity. Stopping the press at the bottom of its stroke, which is usually required in solid-phase forming, can be accomplished with little difficulty. Cushions which are available on most presses for drawing metal are usually too heavy for plastics drawing. For example it is common to have a cushion 12 to 14 inches in diameter with a 50 to 60 ton press. Experience with ABS has shown that this cushion should be reduced to 6 to 8 inches or some type of mechanical spacing mechanism is required to take up the shock at the start of the draw. In one instance, a heavy cushion reportedly broke ABS even though the pressure was limited to that needed to hold up the drawpad (24).

Hydraulic Presses - These are utilized in the solid-phase forming of heavy parts and parts which require an extremely long press stroke. The hydraulic press has a higher initial cost and lower speed than the mechanical press, but has the advantage of superior controllability of speed and load. It can be made to dwell at any point in the stroke and can perform certain operations which would be difficult or impossible to accomplish with a mechanical press. For example, some drawing operations require contact with the billet relatively high up on the stroke.

The tooling concepts which have traditionally been used in the metalworking field can be utilized with little change in the production of plastic parts on this type of equipment. Normally, a high speed double acting hydraulic press of conventional design is preferred.

Rotary Presses - Mechanical or hydraulic rotary presses can be utilized in solid-phase forming of plastic parts. They are used when very high production rates and part quantities are required. The rotary press requires multiple tooling, is very flexible in its programming, and can be made to dwell during part of its cycle. The initial cost of the press is high. However, overall part economy may easily justify the use of this type of press. Rotary presses are generally not standard production tools. They are usually built to specification and are custom designed by the press builders.

TOOLING

The tooling used in solid-phase forming can be of various types and materials depending on the process, material, part design and quantity desired. For more specific information the reader is referred to the tooling discussion under each solid-phase forming process. Tools have been made from both soft and hardenable steel, soft metals such as lead alloys, aluminum, epoxy and wood. Even plaster and cement have been used in prototype tooling.

It is possible to blank, draw and form sheet or coil stock in compound dies. In fact, compound dies perform nicely because you can use available systems with plastics which you can't do with metals due to the lower pressures required. For example, 2,800 psi is sufficient to form a four inch diameter cup and this can be obtained with line pressure with a four to five inch diameter piston (24).

Generally, tools are made in a conventional job machine shop and not a tool and die shop. Conventional die finishes are usually satisfactory. Draw surfaces are normally smooth. An 8 micro inches finish, obtainable from grind machines, is satisfactory for the section of the drawing and the die that are in contact with the material during the draw (6).

Cooling channels may be necessary in molds to maintain the proper temperature in continuous production runs. Die life with hard tooling can be expected to be substantially better than that obtained with metals. Unfilled plastics do not abrade; in fact, the wear caused by the plastic is less than that caused by metal-to-metal contact.

MATERIAL AND PART HANDLING

The handling of material and parts between various operations can be manual, semi-automatic or completely automatic. To obtain the highest production rates possible with standard presses, sheet, strip or blanks should be fed into the press automatically. Generally, the gripper-type feeder has proven to be the most satisfactory; however, a roll-type feeder can be adapted to plastic. Standard pay-off reels used in metal forming are satisfactory with modifications on the feeder to overcome the differences in rigidity between the plastic and metal.

Parts that require multiple operations can be transferred by hand loading or automatically in the web by conveyor, fingers, air blast or vacuum. Automatic web transfer methods are most often used in sheet 0.030 inches or above. During the final operation, the finished part is trimmed from the web. With any method, it is important that very accurate timing and positioning be maintained between the transfer system and the press.

ADVANTAGES AND DISADVANTAGES OF SOLID-PHASE FORMING

The advantages and disadvantages of solid-phase versus melt forming techniques are many and varied and will depend on such factors as: part design, production quantity, type of material, available equipment, part performance requirements, economics, etc. With this in mind, some of the more general advantages and disadvantages are summarized below.

ADVANTAGES

- The typical forming cycle is much faster than conventional methods (excluding billet preheating time) and the speeds are essentially independent of part thickness. Figure 73 depicts the effects of part thickness on forming cycles. Metal inserts can also be formed in place without affecting the cycle time.

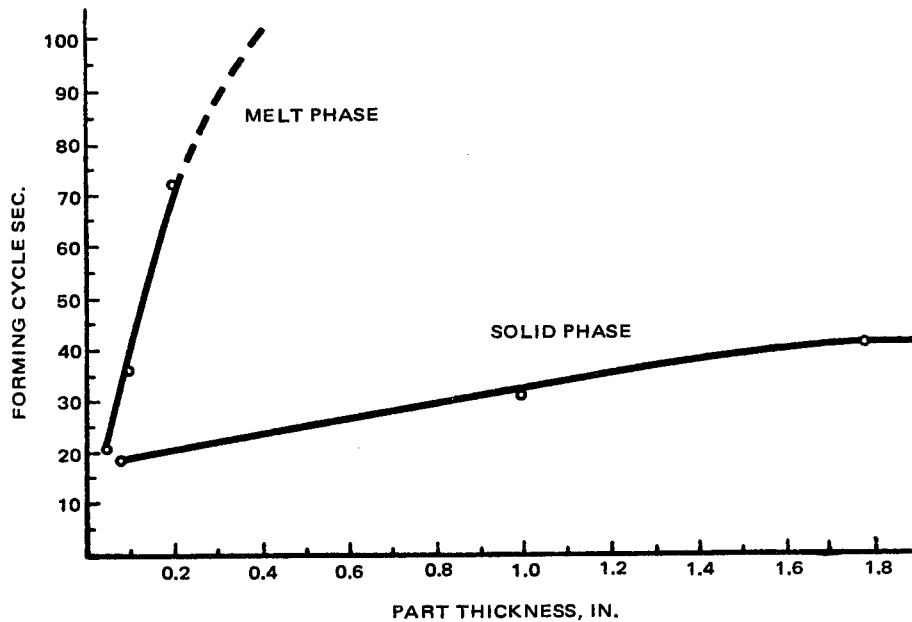

Figure 73. Effect of part thickness on forming speeds (2)

A comparison has been made between drawing and injection molding containers. The production rate of drawn containers is 150 strokes per minute per cavity. Therefore, 1,500 containers can be drawn per minute with a ten cavity die. Injection molding with 64 cavities and a 10 second cycle produces only 384 containers per minute.

- The high speed production of solid-phase formed parts can make plastics competitive with other materials (e.g. metals) in the production of very high volume parts.

- The capability to form parts with very thick sections (several inches) which cannot be made by any other methods except machining.

- Ultra-high molecular weight plastics, generally considered not adaptable to conventional processing methods, can be formed as readily as those of normal molecular weight. This permits utilizing the material's superior properties such as toughness, abrasion resistance, etc. Material with over 4,000,000 molecular weight has been successfully forged (3).

- Tooling is relatively inexpensive; forging tools cost about 35 percent and rubber pad tools about 10 to 15 percent of injection molding counterparts. In some instances solid-phase forming permits use of existing metalworking equipment with only minor modifications.

Normally, prehardened machinable steels with no complex cooling system are required for molds. There is no metal-to-metal contact so hardness is not critical. Tool finishing is usually a good machine finish without fine finish or plating. Very inexpensive, simplified tooling is possible for low volume prototype parts.

- The "cold working" by deformation in the solid-phase increases the toughness and strength of formed parts. This improvement is generally proportional to the amount of cold working involved.

- Solid-phase forming permits the use of preprinted and predecorated material. This provides not only economic advantages but allows a wide latitude in decorating, not possible in other methods - for example, the decoration of recessed or irregular surfaces on the finished part and different colors and decoration on the inside and outside of the part.

- Solid-phase forming produces parts with no flash or trim, sprue marks, weld lines or shrink marks. This reduces scrap and permits good surface finish for decorating and plating.

- Parts can be formed with excellent definition of surface detail, uniform thickness, severe draws or larger taper such as cones.

- Thermal shrinkage of the solid material from its heated state to ambient is considerably less (normally about half) than that encountered for melt forming operations. Mold shrinkage for forged high density polyethylene was reportedly less than one quarter that of injection molded parts (0.006 in./in. versus 0.025 to 0.028 in./in.) (1).

DISADVANTAGES

- There is the extra cost of heating the billet to be overcome since most solid-phase forming processes require a very accurately preheated billet or blank. In fact, oven design and heating techniques are among the most important factors in high quality mass production.

- Solid-phase forming is a multiple step process and involves the added cost of producing and handling billet and blanks. Such costs vary widely with quantity and type of production.

- Elastic recovery or springback must be taken into account in the selection of material, the process and tooling design.

- Part complexity is somewhat limited over the melt techniques but extra tool motions can be used to make more complicated parts. Ribs, undercuts, certain shapes and holes cannot be formed with some of the processes. Also, stress whitening of the part can be a problem with some colors.

- High temperature dimensional stability of formed parts is not as good as those formed by melt techniques. Part distortion temperature will vary with material, design, and processing conditions. However, solid-phase formed parts will revert completely to their original configuration when heated to temperatures in the vicinity of their glass transition temperature (T_g).

ECONOMICS AND SUGGESTED APPLICATIONS

ECONOMICS

The economic advantages of solid-phase forming are found in production speeds; preprinting and decorating flat sheet; minimum material usage; and elimination or reduction of finishing operations such as trimming and machining. To be economically successful, these advantages must offset the additional cost of preparing the billet or blank.

Several studies have been conducted on the economics of solid-phase forming versus other methods. Summaries of some of the studies are given below.

In a production cost study conducted by Frankford Arsenal, AMC Munitions Command on forging versus machining (the only other suitable method) an XM579 polypropylene sabot block showed a \$3.76 per block saving (4). The sabots consisted of four sections approximately five inches long and one and one-half inches thick.

The study was based on the following three assumptions: a production rate of 20,000 blocks per month on a one shift, 8 hour, 5 day week basis; a total production of 1,000,000 blocks; and \$10.00 per man hour including overhead.

The cost of machining blocks from polypropylene rod stock was \$9.10 per block. This cost was based on a manufacturing contract as follows:

Material	\$2.85 per block
Labor = $\frac{0.625 \text{ manhours}}{\text{block}}$ x \$10.00 =	<u>\$6.25 per block</u>
Total =	\$9.10 per block

Since this was a contract, no fixed charges for machining equipment could be determined.

Blocks forged at Frankford Arsenal at a rate of 15 per hour cost \$5.34. A diagram of the operation and costs are given below.

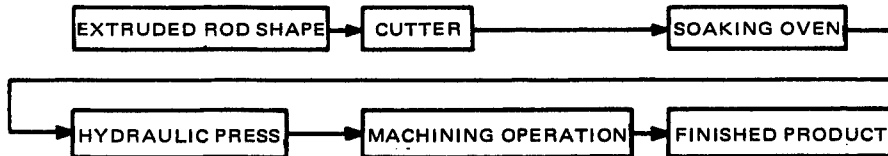

Figure 74. Forging operation (4)

Fixed costs:

<u>Equipment</u>	<u>Cost</u>	<u>Installation</u>
Die	\$ 5,000	\$ 500
Cutter	1,000	500
Oven	5,000	1,000
Press	33,000	5,000
Machining Fixture	1,000	100
Surface Grinder	<u>10,000</u>	<u>3,000</u>
	\$55,000	\$10,100
Total		\$65,100
Cost per block		\$0.065

Production costs:

Material (extruded rod stock)	= \$2.85 per block
Labor	
1 man = cutter and oven	
1 man = press operation	
<u>1 man = machining operation</u>	
Total 3 men = $\frac{0.20 \text{ manhours} \times \$10.00}{\text{block}}$	= \$2.00 per block
10% waste allowance	= <u>\$0.49</u>
Total	= \$5.34

A comparison of the production costs shows that forging provides a substantial savings of approximately \$3.76 per block.

A comparison of various processing costs determined by Marbon Chemical Company for cold drawing acrylonitrile-butadiene-styrene (ABS) versus conventional methods is shown in Table 10.

Table 10. Comparison of Elements of Processing Costs for Cold-drawn ABS Parts with Other Methods of Production (14)

	Injection Molded	Vacuum Formed	Cold-drawn
Speed			
Cycle time, sec.			
Thin section, small part	25	3-4	0.4-0.5
Heavy section, large part	60	60-120	1-10
Number of cavities			
Thin section, small part	1-16	1-35	1-5
Heavy section, large part	1	1	1
Parts/hr.			
Longest cycle, one cavity	60	30	360
Shortest cycle, max. number of cavities	2304	42,000	45,000
Shortest cycle, one cavity	144	1200	9000
Operating cost/hr., \$	5-30	15-25	15-25
Forming cost/1000 parts, \$			
Longest cycle, one cavity	500.00	833.00	69.50
Shortest cycle, max. number of cavities	3.25	0.595	0.555
Shortest cycle, one cavity	34.75	12.50	1.66
Printing and decoration cost/1000 parts, \$			
Round shapes, thin wall, limited decoration	2.50-3.50	2.50-3.50	0.50-1.00
Round shapes, thin wall, quality decoration	5.00 & up	5.00 & up	0.50-1.00
Non-round shapes, thin wall, limited decoration	May be prohibitive	May be prohibitive	0.50-1.00

The advantages of high press speed, 60 to 150 strokes per minute, especially in single cavity operations, and predecoration are well illustrated. Table 11 compares the cost of: vacuum formed ABS and high density polyethylene tubs; vacuum formed and cold drawn ABS tubs; and the cost of manufacturing tubs from supplied sheet with in-house extruded material.

Table 11. Comparison of Costs for Vacuum Forming and Cold Drawing
Soft Margarine Tub (Half-pound, without Lid) (14)

Cost Factors	Vacuum Formed		Cold-drawn ABS (Cycopac 155)
	Low Impact- resistant ABS	High Density Polyethylene	
In-plant production			
Material cost, \$/lb.	0.24	0.19	0.40
Material/unit, gram/part	7.5	8.5	6.5
Material/1000 parts, lb.	16.5	18.7	14.3
Adjusted material usage (5% scrap/1000 parts), lb.	17.3	19.7	15.0
Material cost/1000 parts, \$	4.15	3.74	6.00
Trim scrap, %	35	35	20
Adjusted extrusion requirement, lb./1000 parts	26.6	30.4	18.7
Extrusion cost/1000 parts (at \$.056/lb.), \$	1.60	2.28	1.12
Number of forming cavities	35	35	5
Forming cycle, sec.	3.5	5.0	0.5
Production, parts/hr.	36,000	25,200	36,000
Forming cost, \$/hr.	25.00	25.00	20.00
Forming cost, \$/1000 parts	0.695	0.985	0.555
Cost of regrind, \$/1000 parts (at \$.03/lb.)	0.28	0.32	0.11
Rebate/1000 parts, \$	----	----	0.43 ^a
Undecorated mfg. cost, \$/1000 parts	6.73	7.33	7.36
Decorating cost, \$/1000 parts			
Round parts	3.75	8.75	0.65
Rectangular parts	b	b	0.65
Decorated cost, \$/1000 parts	10.48	16.08	8.01
Working from sheet supplied^c			
Sheet cost/1000 pieces, \$	9.04	10.34	12.15
Scrap return allowance, \$	2.23	2.03	1.48
Number of forming cavities	35	35	5
Forming cycle, sec.	3.5	5.0	0.5
Production, parts/hr.	36,000	25,200	36,000
Forming cost, \$/hr.	25.00	25.00	20.00
Forming cost, \$/1000 parts	0.695	0.985	0.555
Cost of regrind, \$/1000 parts	0.28	0.32	0.11
Decorating cost, \$/1000 parts			
Round	3.75	8.75	Included in sheet cost
Rectangular	b	b	Included in sheet cost
Rebate/1000 parts, \$	----	----	0.43 ^a
Decorated cost, \$/1000 parts	11.535	18.365	10.905

a. Under Borg-Warner license, a rebate is allowed for scrap from approved resin materials.

b. Not economically practical to post decorate small rectangular shapes.

c. Initial costs, i.e., material, trim, scrap, and machine, are same as for in-plant processing.

Source of data: Marbon Chemical Div., Borg-Warner Corp.

In this study the printing and decorating of flat sheet offer the greatest savings. Although drawing offers faster forming speed and uses less material there is no economic advantage due to the higher initial cost of the cold drawing ABS formulation (\$0.24 vs. \$0.40). It is the high speed flexographic or gravure printing methods (500 to 600 ft/min.) which produces the overall savings in this instance.

The reduction in material is due to the thinner sheet material as a result of minimal thinning or stretching in forming; less trim scrap to be re-extruded; and less material weight in the finished part.

Four techniques for fabricating tinned and cellulose acetate butyrate (CAB) aerosol caps are compared in Table 12. As can be seen, the CAB drawn cap compares favorably with the tinned cap and is superior to the injection molding and vacuum forming processes.

Table 12. Comparison of Fabrication Methods of Tinned and CAB Aerosol Caps (25)

Method	Rate of Production	Tool Cost	Precision (Max Error in Diameter)	Heating or Cooling Required	Energy Used	Remarks
Tin box	components/hr 6000	£50-100 (single impression)	in ±0.0015	None	20-80 tons 6-15 hp for 0.05s	Precise control with rapid production attainable. Scrap material cannot be reclaimed.
Cold forming (drawing) CAB	6000	£50-100 (single impression)*	±0.005	None	>10 tons 6-15 hp for 1.0s	Precise control with rapid production possible, but further information required on accuracy. Scrap material can be reclaimed.
Injection moulding CAB	900	£300-500 (four impression)	±0.005	100°-400°C and cooling water	7-15 hp for 16s	Expensive in comparison for thin-wall components. Relies on fluid flow of material and requires strict heat control. Material wastage may be high.
Vacuum forming CAB	1800	£50-100 (four impression)	±0.015	100°-400°C and cooling water	0.5 hp vacuum pump 0.5 hp plug assist. for 8s	Sealing defects with vacuum. Splitting with plug assist. can occur. Lacks precise control and material wastage may be high.

* With a four-impression tool on a gang press the figure of 6000 components per hour would read 24000 components per hour, but tool cost would be of the order of £300-400.

SUGGESTED APPLICATIONS

Solid-phase thermoplastic processing techniques are suitable for a wide range of military and commercial applications because of their many advantages. However, these techniques are limited in forming very intricate parts or parts containing holes or those for high temperature applications. Their military potential lies in the production of high volume thick-section ammunition components which cannot be economically manufactured by conventional methods, for example, the design of the XM579 sabot.*

Other areas where economic or property advantages could be obtained by these techniques are: booster, detonator and primer cups; mine bodies; cartridge cases; reloadable HDPE shells; sabots; rotating bands; gears; washers, cams, rivets, screws and fasteners; pump rotors and valve bodies; pipe fittings; ammunition component containers; instrument cases; messing equipment (trays, food containers, refrigerator door liners); automotive parts such as grilles, transmission covers, dash panels, bumpers, hoods, deck lids, fender liners, door panels, etc.; also all applications requiring stress-free parts without weld lines or shrink marks such as plated parts.

This list can easily become formidable as more experience is gained in solid-phase forming techniques and special material formulations become available. Presently, it should be considered when selecting the manufacturing process for thermoplastic items.

* Frankford Arsenal has submitted a request for \$135,000 in 1972 on Project No. 5726374, PEMA p4932 to apply in-house solid-phase forming processes to the manufacture of heavy wall and/or high strength plastic munitions components which will meet present and future generation ammunition requirements.

REFERENCES AND AUTHORIZATION

1. Werner, A. C. and J. J. Krimm (Celanese Plastics Co.)
"Forging of high molecular weight polyethylene" in 26th ANNUAL TECHNICAL CONFERENCE, SOCIETY OF PLASTICS ENGINEERS, May 6-10, 1968, p619-22.
2. Coffman, P. M. (Shell Chemical Co.)
"Forming of plastics by metalworking techniques" in 26th ANNUAL TECHNICAL CONFERENCE, SOCIETY OF PLASTICS ENGINEERS, May 6-10, 1968, p225-30.
3. Shell Chemical Company
FORGING, STAMPING AND EXTRUSION OF SOLID THERMOPLASTICS, by Paul M. Coffman, 1968.
4. Frankford Arsenal
FEASIBILITY STUDY FOR COLD FORMING OF THE XM 579 SABOTS BLOCKS, by John Bravo, Report #6006, July 1970.
5. Abrams, M., C. E. Spedding and B. J. Marsh
"Solid-phase forming of the polyolefins" in PLASTICS AND POLYMERS, V38, N134, April 1970.
6. Royer, R. G. (Marbon Chemical Co.)
"Cold forming of ABS plastics" in SOCIETY OF PLASTICS ENGINEERS, QUEBEC SECTION, REGIONAL TECHNICAL CONFERENCE, "New Trends in Thermoplastic Sheet Processing", October 1968, Montreal.
7. Staff
"Focus-advanced technology: stamping and forging of plastics" in PLASTICS, V33, N366, April 1968.
8. Hofer, P. H., A. R. Tavorozzi and G. J. Wagerson (GRTL Co.)
"Stamping Azdel - a reinforced thermoplastic sheet", paper presented at INTERNATIONAL AUTOMOTIVE ENGINEERING CONGRESS, Detroit, Michigan, January 13-17, 1969. "By permission of Society of Automotive Engineers, Inc."
9. Borg Warner Corporation, Marbon Division
COLD FORMING CYCOPAC 155 AND CYCOLAC MS, Technical Bulletin, Pb138, undated.
10. Coffman, P. M. (Shell Chemical Co.)
"Diaphragm forming - an advance in solid-phase forming technology" in 27th ANNUAL TECHNICAL CONFERENCE, SOCIETY OF PLASTICS ENGINEERS, Chicago, Illinois, May 5-8, 1969, p498-500.
11. Smoluk, G. R. and M. B. Klaus (Cincinnati Milling Machine Co.)
"Fluid forming machine and process" in MODERN PLASTICS, V45, N15, November 1968.
12. Smoluk, G. R. and M. B. Klaus (Cincinnati Milling Machine Co.)
"Factors affecting cold forming of thermoplastics" in MODERN PLASTICS, V45, N15, November 1968.
13. Kozlowski, R. R. (Diamond Shamrock Corp.)
"Cold forming rigid PVC" in 26th ANNUAL TECHNICAL CONFERENCE, SOCIETY OF PLASTICS ENGINEERS, May 6-10, 1968, p236-9.

14. Staff
"Metalworking for plastics cold stamping ABS-1" in MODERN PLASTICS, V45, N8, April 1968, p124-8.
15. Royer, R. G. and W. R. Meadors (Marbon Chemical Co.)
"Deep drawing of ABS plastic sheet" in 26th ANNUAL TECHNICAL CONFERENCE, SOCIETY OF PLASTICS ENGINEERS, May 6-10, 1968, p231-5.
16. Malpass, V. E. (Borg Warner Corp.)
"Analysis of ABS cold-forming by high speed testing" in APPLIED POLYMER SYMPOSIA, No. 12, 1969, "by permission of John Wiley & Sons, Inc."
17. Koch, P., H. L. Li, H. J. Oswald and D. C. Prevorsek (Allied Chemical Corp.)
"Factors affecting the depth of draw in a cold-forming operation" in AMERICAN CHEMICAL SOCIETY, DIVISION OF POLYMER CHEMISTRY, V10, N2, September 1969.
18. Li, H. L., P. Koch, D. C. Prevorsek and H. J. Oswald (Allied Chemical Corp.)
"Cold forming of plastics. Part 1. Draw forming of thermoplastic sheets" in POLYMER ENGINEERING AND SCIENCE, V11, N2, March 1971.
19. Warshavsky, M. and N. Tokita (Uniroyal, Inc.)
"Cold drawability of thermoplastic sheets" in SPE JOURNAL, Vol 26, No. 8, August 1970.
20. Broutman, L. J., S. Kalpakjian and J. Chawla (Illinois Institute of Technology)
"Deep drawability of biaxially rolled thermoplastic sheets" in 29th ANNUAL TECHNICAL CONFERENCE, SOCIETY OF PLASTICS ENGINEERS, May 10-13, 1971, Washington, D. C.
21. Broutman, L. J. and R. S. Patril (Illinois Institute of Technology)
"Cold rolling of polymers. 1. Influence of rolling on properties of amorphous polymer" in 28th ANNUAL TECHNICAL CONFERENCE, SOCIETY OF PLASTICS ENGINEERS, May 1970, New York; also POLYMER ENGINEERING AND SCIENCE, V11, N2, March 1971.
22. Broutman, L. J. and S. Kalpakjian (Illinois Institute of Technology)
"Cold forming of plastics" in SPE JOURNAL, V25, October 1969, p46-52.
23. Rusch, K. C. and J. R. Forrester, Jr. (Ford Motor Company)
"Recovery rate of cold-rolled polycarbonate" in 29th ANNUAL TECHNICAL CONFERENCE, SOCIETY OF PLASTICS ENGINEERS, May 10-13, 1971, Washington, D. C.
24. Matras, W. F.
"Meeting competition in the 1970's - How we will cold-form plastics" in METAL PROGRESS, V96, N4, October 1969, p165-9.
25. Cheesmore, R. and C. Sanders (Premier Plastics Limited)
"Cold-forming of plastics sheet using conventional tin box machinery", Trans. J. PLASTICS INST., V34, N109, February 1966, p7-10.

BIBLIOGRAPHY

Anonymous

"Cold stamped plastics make debut" *in* STEEL, V160, N15, April 10, 1967.

Anonymous

"Cold formed plastics conduit" *in* RUBBER AND PLASTICS AGE, V49, N7, July 1968.

Broutman, L. J. and S. Kalpakjian (Illinois Institute of Technology)

"Fundamental aspects of cold forming of plastics" *in* 27th ANNUAL TECHNICAL CONFERENCE, SOCIETY OF PLASTICS ENGINEERS, May 5-8, 1969.

Coffman, P. M. (Shell Chemical Co.)

"Warm forging" *in* 1970-1971 MODERN PLASTICS ENCYCLOPEDIA.

Friedland, Martin (E. W. Bliss Company)

"Cold forming of plastics" *in* THE AMERICAN SOCIETY OF MECHANICAL ENGINEERS DESIGN ENGINEERING CONFERENCE, May 11-14, 1970, Chicago, Ill.

Friedland, M.

"Forming plastics parts" *in* AUTOMATION, February 1971.

Haering, R. L. (Crompton and Knowles Corp.)

"Blanking" *in* 1970-1971 MODERN PLASTICS ENCYCLOPEDIA.

Larson, C. E. (Marbon Chemical Co.)

"Applying high speed metal forming technology to plastics" *in* 25th ANNUAL WESTERN SECTION SPI CONFERENCE, San Francisco, May 1-3, 1968.

Larson, C. E. (Marbon Chemical Co.)

"Forging and stamping - cold forming" *in* 1970-1971 MODERN PLASTICS ENCYCLOPEDIA.

Le Grand, R.

"Press stamps plastics" *in* AMERICAN MACHINIST, V113, N21, October 20, 1969.

Lurie, R. D. (Ford Motor Co.)

"Sheet work-thermoforming, cold stamping, warm forging" *in* DESIGN ENGINEERING CONFERENCE, ASME, May 1971, New York, N. Y.

Murray, A. D. and K. C. Rusch (Ford Motor Company)

"Effect of cold rolling on the tensile behavior of polycarbonate" *in* 29th ANNUAL TECHNICAL CONFERENCE, SOCIETY OF PLASTICS ENGINEERS, May 10-13, 1971, Washington, D. C.

Olowin, C. J. (Erie Foundry Co.)

"Hydraulic and mechanical presses" *in* SOCIETY OF PLASTICS ENGINEERS REGIONAL TECHNICAL CONFERENCE, "Reinforced Plastics: Mechanization", Cleveland, Ohio, September 25-26, 1969.

Staff

"Processing facts - cold forming" *in* PLASTICS WORLD, V28, N3, March 1970.

Staff

"Technology - forging shows promise for making plastics parts" *in* CHEMICAL AND ENGINEERING NEWS, March 15, 1971.

Staff

"ABS scores in packaging: preprinted, cold-formed containers" *in* PLASTICS WORLD, May 1971.

Starita, J. M. (General Electric Co.) and M. Keaton (Princeton University)

"Nature of the glass transition temperatures in polymeric systems" *in* 29th ANNUAL TECHNICAL CONFERENCE, SOCIETY OF PLASTICS ENGINEERS, May 10-13, 1971, Washington, D. C.

UNCLASSIFIED

Security Classification

DOCUMENT CONTROL DATA - R & D

(Security classification of title, body of abstract and indexing annotation must be entered when the overall report is classified)

1. ORIGINATING ACTIVITY (Corporate author) Plastics Technical Evaluation Center (PLASTEC) Picatinny Arsenal, Dover, New Jersey 07801		2a. REPORT SECURITY CLASSIFICATION UNCLASSIFIED	
		2b. GROUP n a	
3. REPORT TITLE SOLID-PHASE FORMING (COLD FORMING) OF PLASTICS			
4. DESCRIPTIVE NOTES (Type of report and inclusive dates) State-of-the-Art 1966-1971			
5. AUTHOR(S) (First name, middle initial, last name) Joan B. Titus			
6. REPORT DATE January 1972	7a. TOTAL NO. OF PAGES 95	7b. NO. OF REFS 24	
8a. CONTRACT OR GRANT NO. n a	9a. ORIGINATOR'S REPORT NUMBER(S) PLASTEC Report R42		
b. PROJECT NO. n a	9b. OTHER REPORT NO(S) (Any other numbers that may be assigned this report) None		
c. n a			
d. n a			
10. DISTRIBUTION STATEMENT This document has been approved for public release; its distribution is unlimited. It is available from the National Technical Information Service at \$10.00.			
11. SUPPLEMENTARY NOTES n a		12. SPONSORING MILITARY ACTIVITY Production Equipment Agency, Army Materiel Command	

13. ABSTRACT

This report covers solid-phase forming of plastic parts. These forming concepts involve the use of traditional metal working techniques which are new to the field of thermoplastic part production. Discussed are: the various solid-phase forming processes; thermoplastic materials suitable to these methods; part design; advantages and disadvantages of the processes; equipment and tooling requirements; processing effects on part properties; production economics and suggested applications suitable to these techniques.

14. KEY WORDS	LINK A		LINK B		LINK C	
	ROLE	WT	ROLE	WT	ROLE	WT
Cold forming Thermoplastics Solid-phase forming Processing Fabrication Drawing Forging Stamping						

UNCLASSIFIED

1. Thermoplastics - solid-phase forming
2. Fabrication - solid-phase forming
3. Solid-phase forming - forging, stamping, drawing
4. Drawing, forging, stamping - thermoplastics

I. Titus, Joan B.
II. Title

UNITERMS

Cold forming
Thermoplastics
Solid-phase forming
Processing
Fabrication
Drawing
Forging
Stamping

DISTRIBUTION

Public sale through NTIS. Price \$10.00.

AD _____ Accession No. _____

Plastics Technical Evaluation Center (PLASTEC)
Picatinny Arsenal, Dover, New Jersey 07801

SOLID-PHASE FORMING (COLD FORMING) OF PLASTICS

PLASTEC Report R42, January 1972, 95 pp.
Unclassified Report

This report covers solid-phase forming of plastic parts. These forming concepts involve the use of traditional metal working techniques which are new to the field of thermoplastic part production. Discussed are: the various solid-phase forming processes; thermoplastic materials suitable to these methods; part design, advantages and disadvantages of the processes; equipment and tooling requirements; processing effects on part properties; production economics and suggested applications suitable to these techniques.

UNCLASSIFIED

1. Thermoplastics - solid-phase forming
2. Fabrication - solid-phase forming
3. Solid-phase forming - forging, stamping, drawing
4. Drawing, forging, stamping - thermoplastics

I. Titus, Joan B.
II. Title

UNITERMS

Cold forming
Thermoplastics
Solid-phase forming
Processing
Fabrication
Drawing
Forging
Stamping

DISTRIBUTION

Public sale through NTIS. Price \$10.00.

UNCLASSIFIED

1. Thermoplastics - solid-phase forming
2. Fabrication - solid-phase forming
3. Solid-phase forming - forging, stamping, drawing
4. Drawing, forging, stamping - thermoplastics

I. Titus, Joan B.
II. Title

UNITERMS

Cold forming
Thermoplastics
Solid-phase forming
Processing
Fabrication
Drawing
Forging
Stamping

DISTRIBUTION

Public sale through NTIS. Price \$10.00.

AD _____ Accession No. _____

Plastics Technical Evaluation Center (PLASTEC)
Picatinny Arsenal, Dover, New Jersey 07801

SOLID-PHASE FORMING (COLD FORMING) OF PLASTICS

PLASTEC Report R42, January 1972, 95 pp.
Unclassified Report

This report covers solid-phase forming of plastic parts. These forming concepts involve the use of traditional metal working techniques which are new to the field of thermoplastic part production. Discussed are: the various solid-phase forming processes; thermoplastic materials suitable to these methods; part design, advantages and disadvantages of the processes; equipment and tooling requirements; processing effects on part properties; production economics and suggested applications suitable to these techniques.

UNCLASSIFIED

1. Thermoplastics - solid-phase forming
2. Fabrication - solid-phase forming
3. Solid-phase forming - forging, stamping, drawing
4. Drawing, forging, stamping - thermoplastics

I. Titus, Joan B.
II. Title

UNITERMS

Cold forming
Thermoplastics
Solid-phase forming
Processing
Fabrication
Drawing
Forging
Stamping

DISTRIBUTION

Public sale through NTIS. Price \$10.00.

AD _____ Accession No. _____

Plastics Technical Evaluation Center (PLASTEC)
Picatinny Arsenal, Dover, New Jersey 07801

SOLID-PHASE FORMING (COLD FORMING) OF PLASTICS

PLASTEC Report R42, January 1972, 95 pp.
Unclassified Report

This report covers solid-phase forming of plastic parts. These forming concepts involve the use of traditional metal working techniques which are new to the field of thermoplastic part production. Discussed are: the various solid-phase forming processes; thermoplastic materials suitable to these methods; part design, advantages and disadvantages of the processes; equipment and tooling requirements; processing effects on part properties; production economics and suggested applications suitable to these techniques.

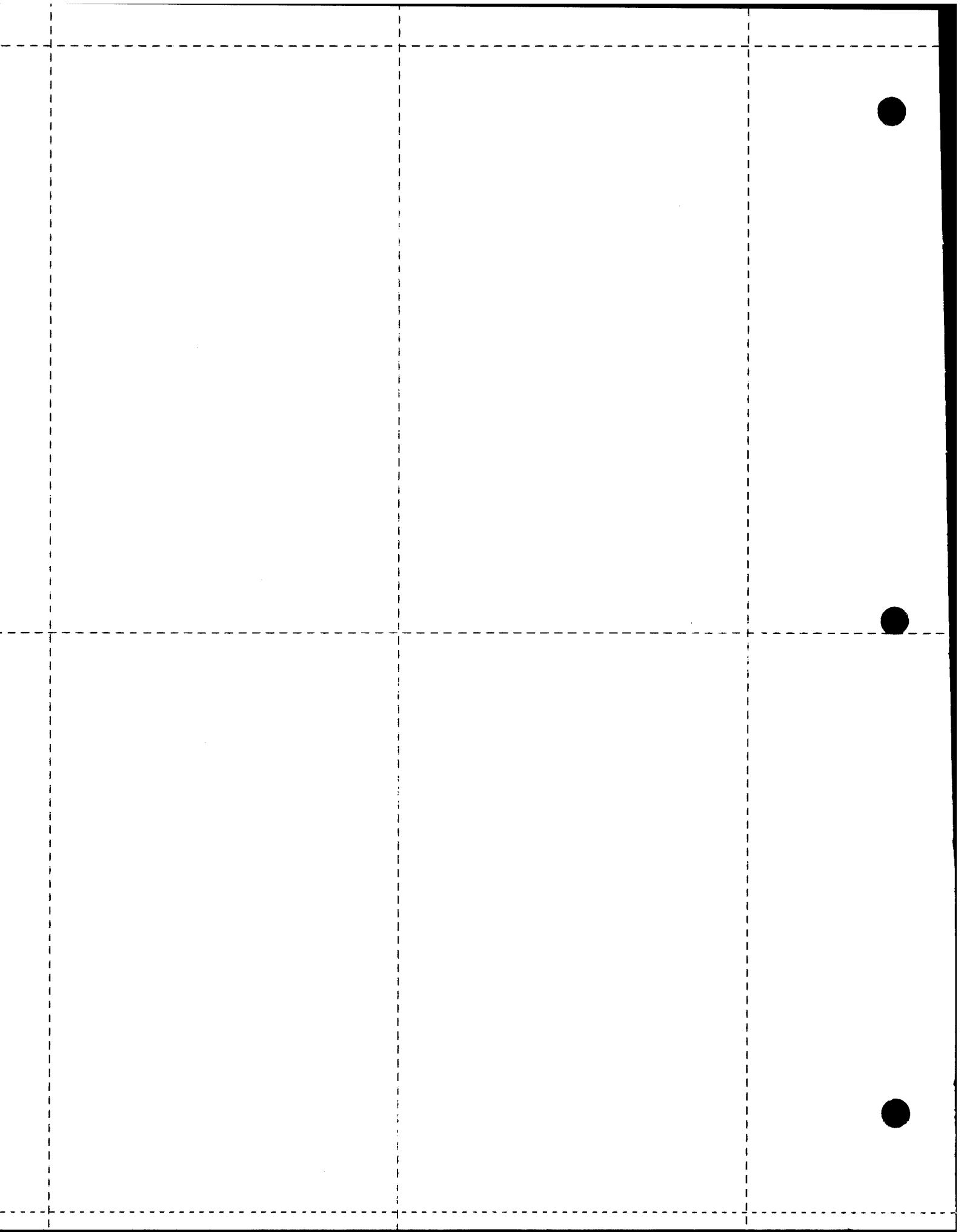

PLASTEC Publications, Since 1968

(Complete list available on request)

REPORTS

5C	<i>Directory in Plastics - Knowledgeable Government Personnel (Revised)</i> , by N.E. Beach, Apr 1969 (Price \$6.00)	AD 692 997
32	<i>The Weatherability of Polyolefins</i> , by Joan B. Titus, March 1968 (Price \$6.00)	AD 672 513
33	<i>Compatibility of Explosives with Polymers (II) (An Addendum to Picatinny Arsenal Technical Report 2595)</i> , by N.E. Beach and V.K. Canfield, April 1968 (Price \$6.00)	AD 672 061
34	<i>Survey of Plastics Sandwich Construction</i> , by N.T. Baldanza, May 1968 (Price \$6.00)	AD 673 713
35	<i>Subject Index, Bibliography, and Code Description of Technical Conference Papers on Plastics: May 1967-May 1968</i> , by Joan B. Titus and A.E. Molzon, Aug 1968 (Price \$6.00)	AD 676 189
36*	<i>A Bibliography of Ablative Composites and Polymers</i> , by A.M. Shibley, July 1968	AD 855 720
37	<i>Polyurethane Foams: Technology, Properties and Applications</i> , by A.H. Landrock, Jan 1969 (Price \$15.50)	AD 688 132
38	<i>Weatherability of Polystyrenes and Related Copolymers and Terpolymers</i> , by Joan B. Titus, July 1969 (Price \$6.00)	AD 700 091
39	<i>Subject Index, Bibliography, and Code Description of Technical Conference Papers on Plastics: 15 May 1968-8 May 1969</i> , by Joan B. Titus and A.E. Molzon, Dec 1969 (Price \$8.00)	AD 707 246
40	<i>Compatibility of Explosives with Polymers (III), An Addendum to Picatinny Arsenal TR 2595 and PLASTEC Report 33</i> , by N.E. Beach and V.K. Canfield, Jan 1971 (Price \$6.00)	AD 721 004
41	<i>Applications of Ionizing Radiations in Plastics and Polymers Technology</i> , by A.F. Readdy, Jr., March 1971 (Price \$12.00)	AD 725 940

NOTES

6B	<i>Government Specifications and Standards for Plastics, Covering Defense Engineering Materials and Applications (Revised)</i> by N.E. Beach, June 1969 (Price \$4.00)	AD 697 181
9A	<i>Trade Designations of Plastics and Related Materials (Revised)</i> , by Joan B. Titus, May 1970 (Price \$6.00)	AD 715 401
18	<i>The Coating of Aluminum with Plastics by the Fluidized-Bed and Electrostatic Powder Techniques</i> , by A.H. Landrock, Feb 1968 (Price \$6.00)	AD 666 224
19	<i>Polymer Synthesis: A Survey of Government Contracts Since 1960</i> , by A.E. Molzon, Jan 1968 (Price \$6.00)	AD 666 758
20	<i>Literature Survey on Thermal Degradation, Thermal Oxidation, and Thermal Analysis of High Polymers (III)</i> , by D.A. Teetsel and D.W. Levi, Nov 1969 (Price \$10.00)	AD 706 811
21	<i>Literature Search: Injection Molding Processing Parameters</i> , by N.T. Baldanza, July 1969 (Price \$3.00)	AD 703 530
22	<i>Compatibility of Explosives with Polymers: A Guide to the Reactions Reported in Picatinny Arsenal Technical Report 2595</i> , March 1959, by M.C. St. Cyr and N.E. Beach, Oct 1970 (Price \$3.00)	AD 716 624

On public sale at the National Technical Information Service (NTIS) at the stated price; prepayment required; use the order number.

* Available to qualified persons only, at a price of \$5.50.