

NASA TECHNICAL NOTE

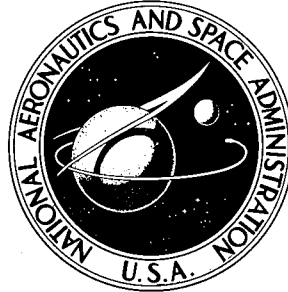

NASA TN D-4463

NASA TN D-4463

DISTRIBUTION STATEMENT A
Approved for public release
Distribution Unlimited

19960506 009

WEAR RATE AND FRICTION COEFFICIENT
IN LIQUID NITROGEN AND HYDROGEN OF
STEEL SLIDING ON POLYMER LAMINATES
(VARIOUS FABRICS AND POLYMERS)

by Donald W. Wisander and Robert L. Johnson

*Lewis Research Center
Cleveland, Ohio*

DEIG QUALITY INSPECTED 1

PLASTEC 11099

NATIONAL AERONAUTICS AND SPACE ADMINISTRATION • WASHINGTON, D. C. • APRIL 1968

DEPARTMENT OF DEFENSE
ELASTICS TECHNICAL EVALUATION CENTER
PICATINNY ARSENAL, DOVER, N. J.

WEAR RATE AND FRICTION COEFFICIENT IN LIQUID NITROGEN AND HYDROGEN OF STEEL SLIDING ON POLYMER LAMINATES (VARIOUS FABRICS AND POLYMERS)

by Donald W. Wisander and Robert L. Johnson

Lewis Research Center

SUMMARY

Wear rates and coefficients of friction of polymer laminates were determined in environments of liquid nitrogen and liquid hydrogen. The polymers included PTFE (polytetrafluoroethylene), phenolic, epoxy, and melamine; the fabrics included glass, graphite, nylon, and cotton. The reference material used was not a laminate (80 percent PTFE, 15 percent glass fiber, and 5 percent graphite).

Wear and friction experiments were conducted with a 3/16-inch- (4.8-mm-) radius hemispherical rider sliding on a flat disk, which was rotated to produce sliding velocities of 2300 feet per minute (701 m/min). The 304 stainless-steel riders were under a 1-kilogram load against the polymer laminate disks.

The results of this investigation indicated that the graphite-fabric phenolic laminate is a potentially useful material for sliding contact in liquid nitrogen and that glass-fabric PTFE and graphite-fabric PTFE laminates are potentially useful in both liquid nitrogen and liquid hydrogen. The wear rates and coefficients of friction of 304 stainless-steel riders against the laminates were appreciably lower in liquid nitrogen than in liquid hydrogen.

INTRODUCTION

Solid surfaces, under sliding and rolling contact in liquid-nitrogen and in liquid-hydrogen environments, are found in many mechanical devices employed in cryogenic applications (refs. 1 to 3). For example, some turbopumps used to transfer cryogenic fluids have rolling-element bearings and contact seals submerged in the cryogenic fluid; proper lubrication of the bearings and seals is vital to their performance and life.

Cryogenic liquids, in general, fill only one of the various functions normally provided by a lubricant, that of cooling. The low viscosities of liquid nitrogen and liquid hydrogen preclude the development of a significant hydrodynamic load-carrying capacity; the chemical nature of these fluids prevents the repair of worn surface-oxide films which are vital to the boundary lubrication of metallic materials (refs. 4 and 5). Because of the limiting physical and chemical properties of cryogenic fluids, the sliding and rolling surfaces should be either inherently self-lubricating or protected by a solid-film lubricant.

The potential usefulness of the self-lubricating principle has been shown in friction and wear studies on filled polymers (refs. 6 and 7). This self-lubricating principle (through the use of filled polymers or polymer-laminate cages) has been used with ball bearings operating in liquid nitrogen (ref. 8) and in liquid hydrogen (ref. 9). It is pointed out in reference 9 that moderate cage wear occurred even with the best material, which was a glass-fiber-filled polytetrafluoroethylene (PTFE). (A similar material with 15 percent glass fiber, 5 percent graphite, and 80 percent PTFE was used as a reference material in the present study.)

Inspection of the published data (refs. 8 to 11) indicates that improved materials are needed and that polymers require some type of filler to improve friction and wear properties. For example, wear of polyimide was reduced through the addition of copper powder and copper fiber (ref. 11); wear of PTFE was reduced through the addition of glass fiber (refs. 9 and 10). The use of fabrics as polymer strengtheners has also been evaluated for friction and wear in a cryogenic environment (refs. 5, 7, and 12). In these experiments, however, the fabric orientation was perpendicular to the sliding direction.

The objectives of this investigation were

- (1) To determine the friction and wear properties of various polymers strengthened by fabrics (oriented parallel to the sliding direction) in liquid nitrogen and in liquid hydrogen
- (2) To compare the friction and wear properties of various polymer laminates obtained in liquid nitrogen with those obtained in liquid hydrogen

The polymer resins used in the evaluations were PTFE, phenolic, melamine, and epoxy; the fabric materials used were cotton, graphite, glass, and nylon. The reference material and the polymer-fabric laminates (polymer laminates) were evaluated in liquid hydrogen and in liquid nitrogen.

MATERIALS

The type of polymer-laminate construction used for the materials tested herein is shown schematically in figure 1(a). The material (disk specimen) consists of a stack of

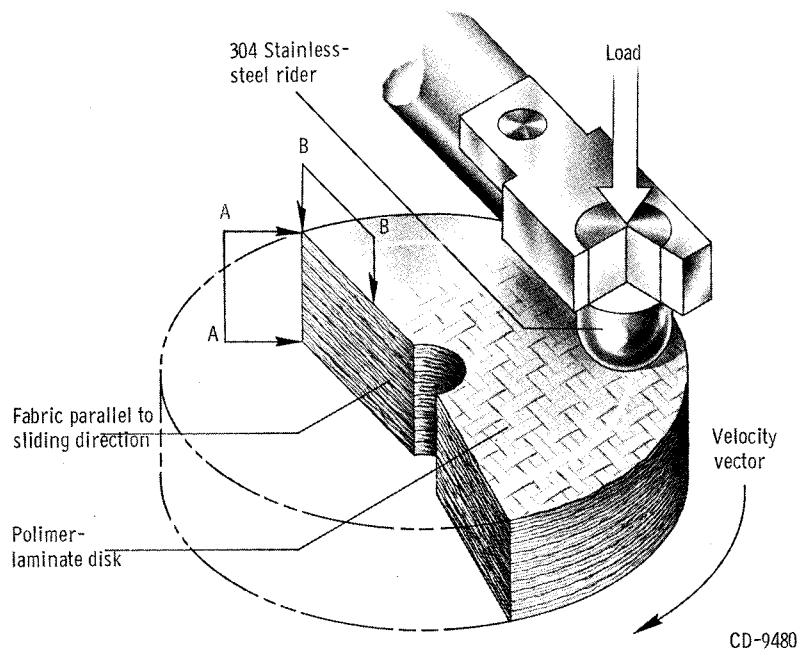

(a) Schematic diagram of disk specimen showing relation of fabric orientation to rider.

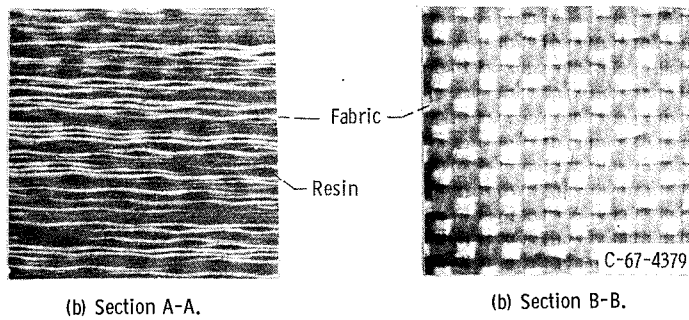

Figure 1. - Typical polymer-laminate disk construction.

polymer-saturated sheets of fabric in layers that have been thermally cured under pressure. The fabric is a woven cloth (2 to 10 oz/sq yd or 68 to 340 g/m²) and is shown in figures 1(b) and (c). Some properties of these laminated materials are given in table I.

Processing of the material is as follows:

(1) The fabric is chosen on the basis of use, for example, a fine fabric where a fine finish is required and a strong fabric for heavy mechanical applications. It is extremely important that the fabric be made from balanced yarn - twisted in one direction and plied in the opposite direction. The fabric should be stored under controlled conditions of moisture and temperature to avoid problems associated with dimensional changes.

(2) The resin is dissolved in a suitable solvent (the solution is referred to as a

TABLE I. - POLYMER-LAMINATE MATERIALS USED

Polymer laminate		Number of fabric threads per unit length		Temperature					
Fabric	Polymer	Threads in.	Threads cm	Room		140° R (77° K)		37° R (20° K)	
				Ultimate tensile strength					
				psi	N/m ²	psi	N/m ²	psi	N/m ²
Glass	Melamine	23	9	-----	-----	-----	-----	-----	-----
Glass	Epoxy	41	16	55×10 ³	385×10 ⁶	75×10 ³	525×10 ⁶	110×10 ³	770×10 ⁶
Glass	Polytetrafluoro-ethylene	41	16	50×10 ³	350×10 ⁶	-----	-----	70×10 ³	490×10 ⁶
Graphite	Phenolic	15	6	-----	-----	-----	-----	-----	-----
Graphite	Polytetrafluoro-ethylene	13	5	-----	-----	-----	-----	-----	-----
Cotton	Phenolic	81	32	-----	-----	-----	-----	-----	-----
Nylon	Phenolic	71	28	-----	-----	-----	-----	-----	-----

varnish) and stored in air-tight drums in air-conditioned rooms. Safety clothing is generally needed because resins are toxic to the skin and membranes.

(3) The fabric is dipped in the varnish, squeezed by rollers to remove the excess varnish (as required), and then passed through a controlled-temperature oven to dry. The amount of resin in the fabric is determined by the roller pressure, the absorption properties of the fabric, the speed of travel through the solution, the temperature of the solution, and the type of fabric used. (An amount of 20 to 80 percent resin is possible.)

(4) The cloth (in roll form) is cut into sheets, which are sorted and graded for thickness and quality. Flat sheets are then placed in layers (sandwiched); tubes or rods are rolled. The sandwich is then placed in an oven (between steam- or hot-water-heated platens) and compressed at 300° to 350° F (149° to 177° C) and 1000 to 1200 psi (6895 to 8274 N/m²) for 1/2 to 12 hours, depending on resin, fabric, thickness, and use. The resin is now transformed from a soluble, fusible condition to an insoluble, infusible state.

(5) The laminate is then postcured by very slowly reducing the temperature (to avoid cracking or warping the surface layers). Sometimes a separate oven is used to accomplish this curing. The manufacture, processing, finishing, and quality control of polymer laminates are presented in reference 13, and the physical properties of several laminates at cryogenic temperatures are given in reference 4.

APPARATUS AND PROCEDURE

The cryogenic friction apparatus used in this investigation is shown schematically in

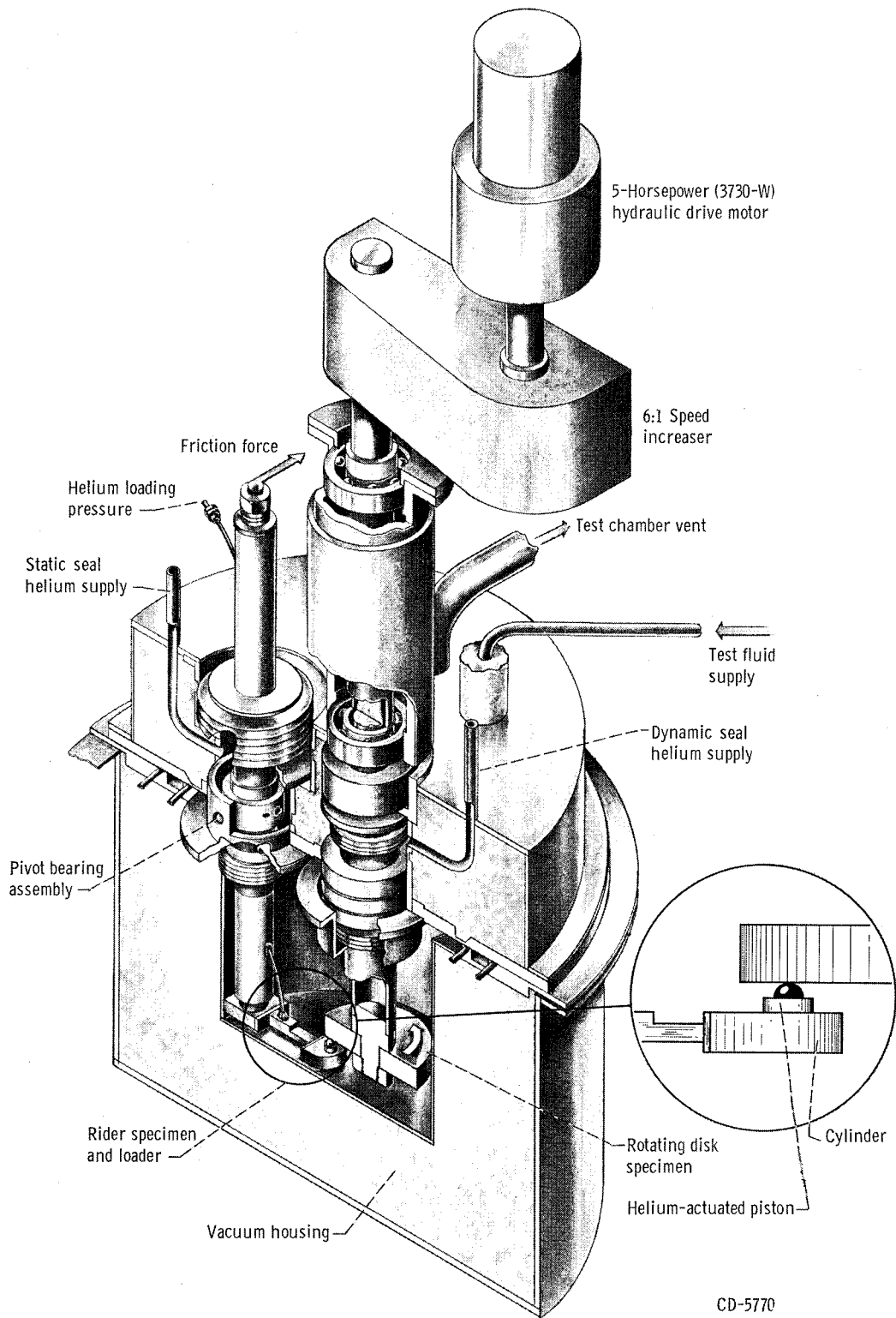

Figure 2. - Cryogenic friction apparatus.

figure 2. The basic elements consist of a hemispherically tipped ($3/16$ -in. - or 4.8-mm-radius) rider specimen held in sliding contact with the lower, flat surface of a rotating disk ($2\frac{1}{2}$ -in. or 6.3-cm diam). The rider specimen, supported by a pivoted arm and bellows assembly, was loaded (1 kg) against the rotating disk specimen by a helium-pressurized piston. A dynamometer ring that restrained the pivoted arm measured the friction force, which was recorded on a readout potentiometer. The drive shaft, which supported the disk specimen, was driven by a hydraulic motor through a 6:1 speed increaser and provided a sliding velocity of 2300 feet per minute (701 m/min) for the data reported herein. The duration of most runs was $1/2$ hour. The wear of the rider specimen was determined by measuring the wear-scar diameter and calculating the wear volume. Two sets of helium-purged contact seals were used to prevent air leakage in and test fluid leakage out around the drive shaft.

The test chamber was cleaned with 100 percent ethyl alcohol prior to each run. After the cleaning, the test chamber was closed, purged for 15 minutes with either nitrogen or helium gas, and filled with the operating liquid through a closed loop. The tests were conducted with the specimen submerged in the liquid. Entirely different results are obtainable with the same combination of materials if tests are conducted above the liquid rather than in the liquid. The different effect on the friction coefficient of testing the specimens in liquid and in gaseous nitrogen is shown in figure 3. The friction coefficient increases in magnitude and roughness in the gaseous environment. Figure 3 is idealized because the high friction coefficient does not decrease in value immediately, but goes through a transitional stage whereby the decrease occurs in steps requiring 2 to 3 minutes to return to the final value. Note also that the friction coefficient increases slightly between alternate phases, which indicates that surface damage has occurred; this is indicated by the considerably greater wear rate obtained when a test was conducted in the gas phase. Higher friction and wear are caused by

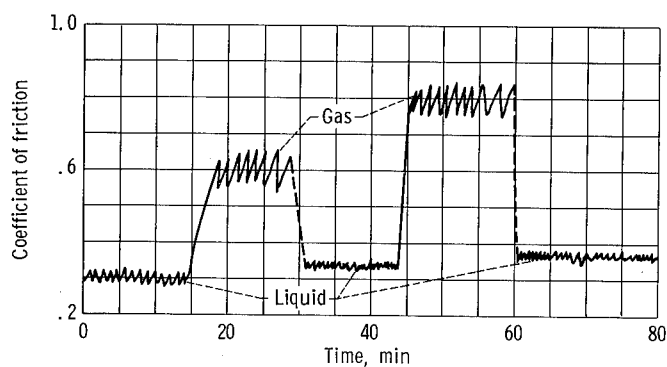

Figure 3. - Effect of phase change on coefficient of friction of polymer sliding against 304 stainless-steel rider in liquid nitrogen. Sliding velocity, 2300 feet per minute (701 m/min); load, 1 kilogram.

the change of the surface finish of the disk, the thermal degradation of the polymer, and an increased thickness of the transfer film on the metal rider surface.

Metal rider specimens were prepared by the following procedure: (1) scrubbing with moist levigated alumina, (2) washing in tap water, (3) washing in distilled water, and (4) drying and storing in a desiccator.

Polymer-laminate disk specimens were cleaned by the following procedure: (1) washing and soaking with ACS certified acetone or 100 percent ethyl alcohol, (2) drying in vacuum (15 mm of Hg or $2 \times 10^3 \text{ N/m}^2$) for 48 hours, (3) purging with dry nitrogen gas slightly above atmospheric pressure introduced into the vacuum chamber after evacuation; and (4) storing in a desiccator for at least 48 hours before use.

RESULTS AND DISCUSSION

Wear and Friction in Liquid-Nitrogen Environment

Figure 4 shows the wear and friction results for 304 stainless-steel riders sliding against various polymer-laminate disks submerged in liquid nitrogen. A comparison of the results shows that melamine was the only material that caused higher rider wear than did the reference material (15 percent glass fiber, 5 percent graphite, 80 percent

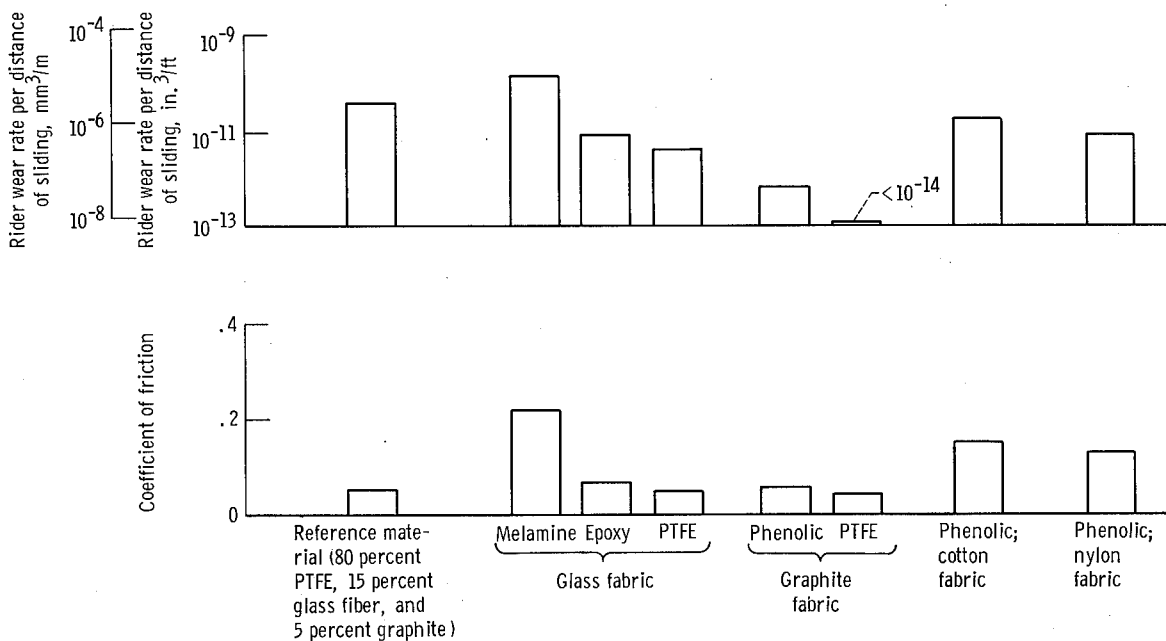

Figure 4. - Wear and coefficient of friction of 304 stainless-steel riders sliding against various polymer-laminate disks in liquid nitrogen. Fabric oriented parallel to sliding direction; sliding velocity, 2300 feet per minute (701 m/min); load, 1 kilogram; duration of sliding, 1/2 hour.

PTFE). The friction coefficients of these materials were similar to that of the reference material.

The rider wear rate and coefficient of friction were lower against graphite-fabric phenolic than against nylon or cotton phenolic. Further evidence of the potential usefulness of graphite-fabric laminates is found in the comparison of the graphite-fabric PTFE laminate and glass-fabric PTFE laminate: graphite-fabric PTFE laminate produced the lower rider wear, although the friction coefficients of all the laminates were comparable.

Figure 5 shows typical rider wear scars and corresponding wear tracks on the glass-fabric PTFE and on the graphite-fabric phenolic disks. Rider wear scars were smooth and polished (except for glass-fabric melamine). The disk wear for these polymer laminates is difficult to measure because the surface is too rough for a profile stylus to follow. Moisture absorption by the specimen prevents getting accurate wear data by weighing, and, therefore, only visual observations were made. All wear tracks appeared smooth (although indentations were found which indicated subsurface voids) except for the glass-fabric melamine, which was very rough. One material (epoxy laminate)

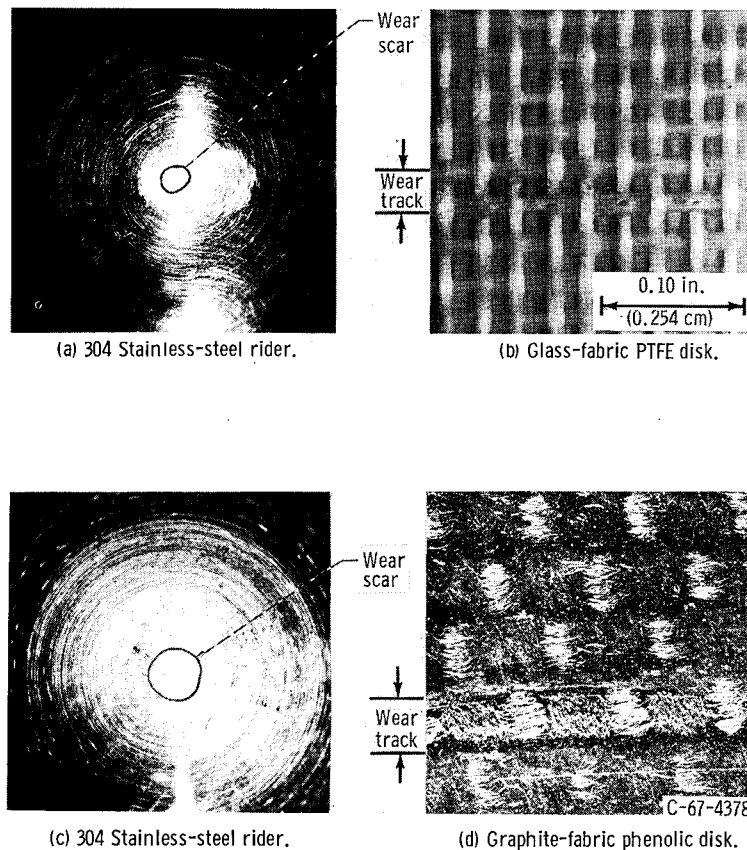

Figure 5. - Wear surfaces of two polymer-laminate - metal combinations after sliding in liquid nitrogen. Sliding velocity, 2300 feet per minute (701 m/min); load, 1 kilogram; duration, 1 hour.

which appeared good on the basis of friction, wear, and surface appearance was not considered potentially useful because delamination (about 1/4 in. or 6.4 mm) of the inside and the outside diameters occurred. Thus, for longer periods of operation, the graphite-fabric PTFE would cause the least mating surface wear and can be considered the best candidate for liquid-nitrogen applications.

The tests reported thus far were conducted with the fabric oriented parallel to the direction of motion. Figure 6 shows the results obtained in liquid nitrogen with rider specimens of cotton-fabric phenolic and of glass-fabric melamine with the fabric orientation perpendicular and parallel to the direction of motion. Note that both the friction and wear of these polymers are lower with the parallel orientation. (Abrasion of the metal mating surface was also decreased with this orientation.)

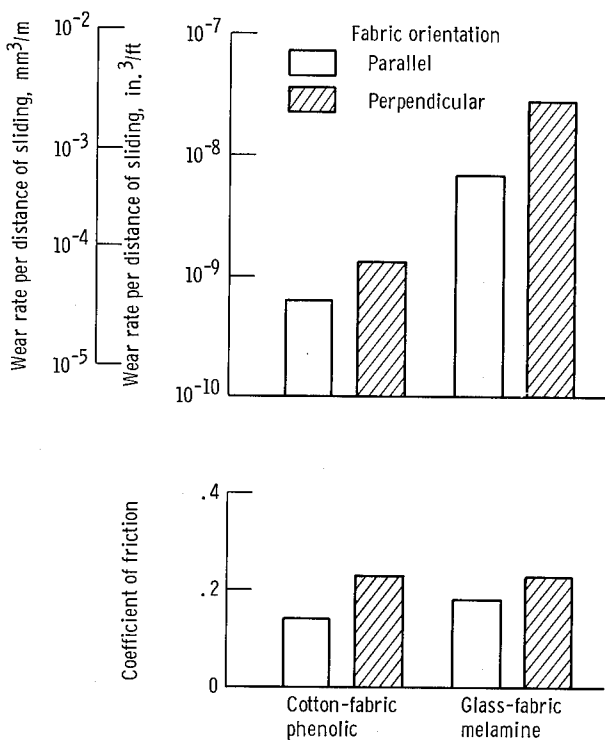

Figure 6. - Effect of fabric orientation on coefficient of friction and wear of two polymer-laminate riders sliding on 304 stainless steel in liquid nitrogen. Sliding velocity, 2300 feet per minute (701 m/min); load, 1 kilogram; duration, 1/2 hour.

Wear and Friction in Liquid-Hydrogen Environment

The wear and friction results for 304 stainless-steel riders sliding against various polymer-laminate disks submerged in liquid hydrogen are presented in figure 7. A comparison of results shows that the lowest rider wear was obtained for specimens sliding against graphite-fabric PTFE. Comparing the friction coefficients of these materials with that of the reference material revealed that they were similar with the exception of glass-fabric melamine.

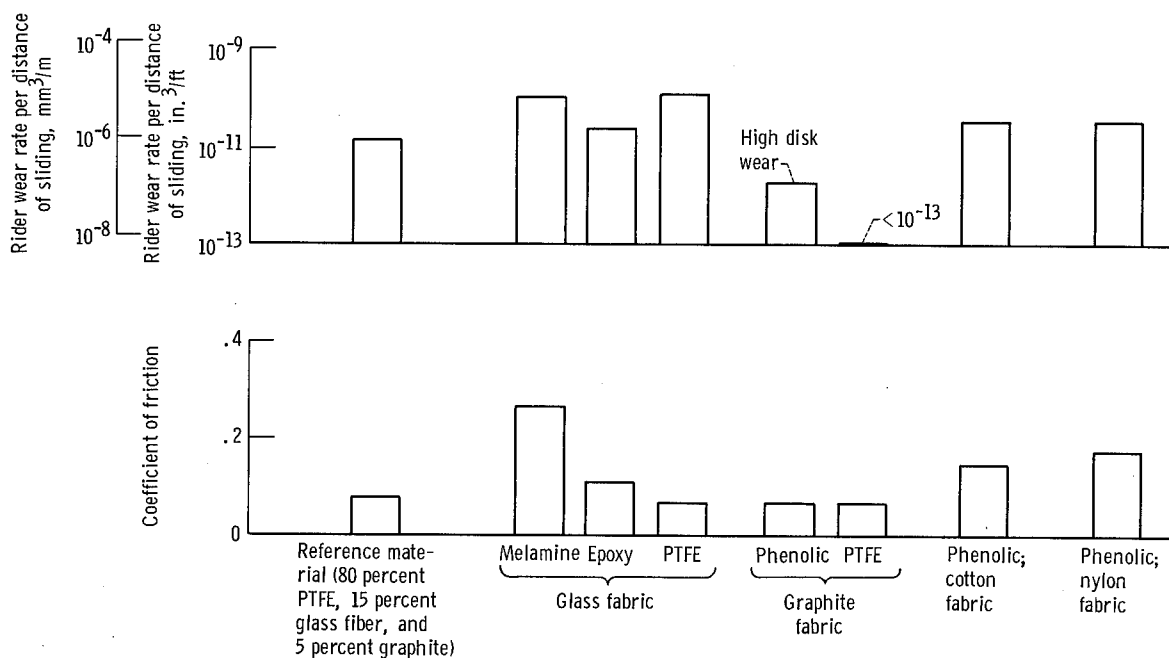

Figure 7. - Wear and coefficient of friction of 304 stainless-steel riders sliding against various polymer-laminate disks in liquid hydrogen. Fabric oriented parallel to sliding direction; sliding velocity, 2300 feet per minute (701 m/min); load, 1 kilogram; duration of sliding, 1/2 hour.

The wear and friction (fig. 7) of the 304 stainless-steel rider was the lowest against the graphite-fabric phenolic laminate, but the disk wear was high. (The rider went half-way through the disk in 30 min.) Figure 7 also shows the advantage of using graphite-fabric PTFE rather than glass-fabric PTFE, that is, there is lower rider wear.

Photographs of the wear surfaces of graphite-fabric phenolic and graphite-fabric PTFE, along with their respective riders, in liquid hydrogen are presented in figure 8. Rider specimens run in liquid hydrogen were less smooth than those run in liquid nitrogen; the wear scar diameters were also elliptical in liquid hydrogen. The polymer-

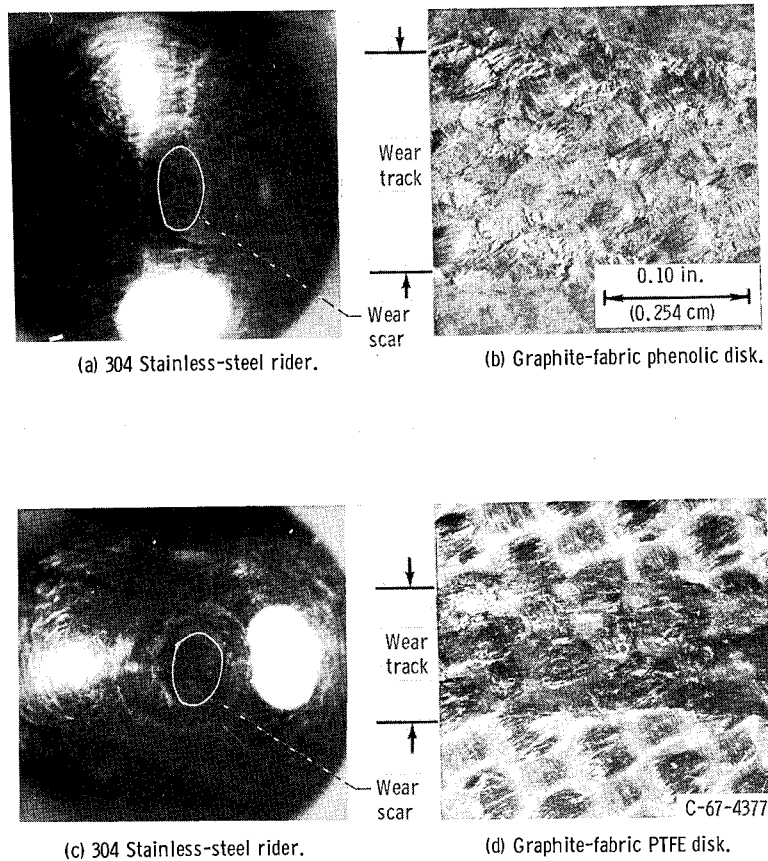

Figure 8. - Wear surfaces of two polymer-laminate - metal combinations after sliding in liquid hydrogen. Sliding velocity, 2300 feet per minute (701 m/min); load, 1 kilogram; duration $\frac{1}{2}$ hour.

laminate materials are more brittle in liquid hydrogen. This brittleness permitted the rider to fracture the disk surface and, subsequently, allowed the rider to penetrate the surface at the tip of the hemisphere. This penetration forced the rider to wear on the side of the hemisphere instead of on the end. After wearing the polymer laminate sufficiently, the rider end again touched the bottom of the wear track; this process produced an oval-shaped wear scar. (About 5 percent of the wear was on the sides of the hemisphere.) Under compression, PTFE is less brittle than the other polymers and plastically deforms to reduce the side wearing of the rider. Glass-fabric epoxy displayed relatively good friction and wear properties, but had a tendency to delaminate at the edges, even to the extent of warping the contacting surface. Because of the greater brittleness of the polymers at the lower temperature, disk wear tracks are less smooth, particularly in the case of melamine. These results showed again that the best material is the graphite-fabric PTFE laminate.

Comparison of Results in Liquid Nitrogen and in Liquid Hydrogen

Disk wear was more severe in liquid hydrogen than in liquid nitrogen because the lower temperatures increased the brittleness of the polymer laminate. The friction coefficients of the polymer laminates (fig. 9) in liquid nitrogen were similar to those in liquid hydrogen; rider wear for all materials was noticeably greater in liquid hydrogen. Of all the materials tested, glass-fabric PTFE and graphite-fabric PTFE gave the best performance in terms of friction, wear, and integrity in liquid nitrogen and in liquid hydrogen.

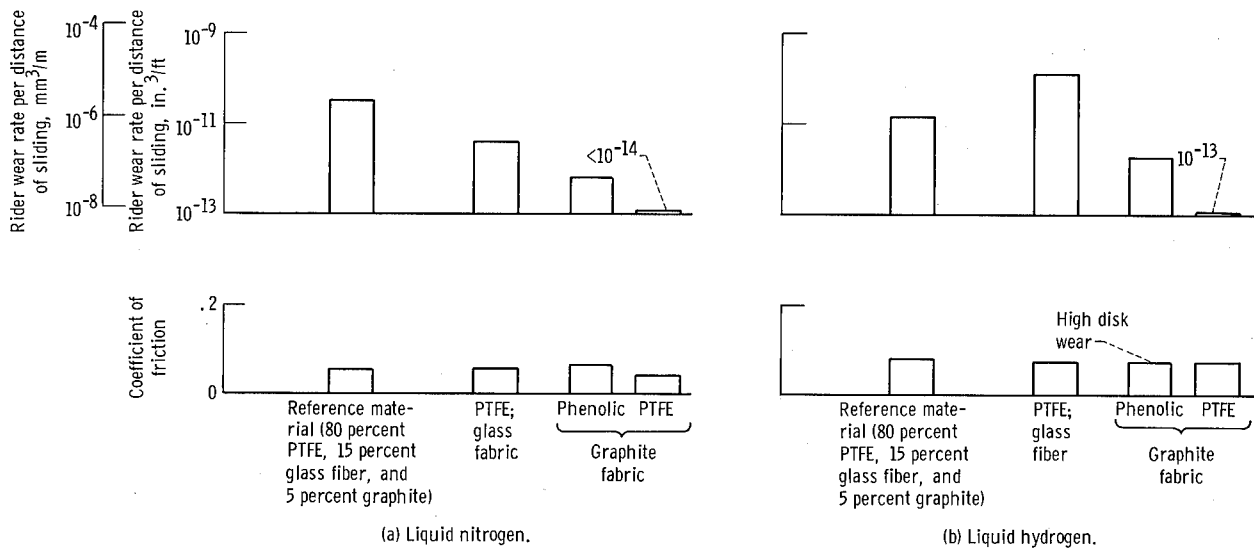

Figure 9. - Comparison of wear and coefficient of friction of 304 stainless-steel rider sliding against various polymer laminates in liquid nitrogen and in liquid hydrogen. Fabric oriented parallel to sliding direction; sliding velocity, 2300 feet per minute (701 m/min); load, 1 kilogram; duration of sliding, 1/2 hour.

SUMMARY OF RESULTS

Wear and friction studies of 304 stainless-steel riders sliding against polymer-laminate disks in environments of liquid nitrogen and of liquid hydrogen revealed the following:

(1) In liquid hydrogen, wear of the 304 stainless-steel rider against the glass-fabric PTFE (polytetrafluoroethylene) laminate and against the graphite-fabric PTFE laminate was significantly lower than wear of the 304 stainless steel against the reference material (80 percent PTFE, 15 percent glass fiber, and 5 percent graphite).

(2) Graphite-fabric phenolic, glass-fabric PTFE, and graphite-fabric laminates are potentially useful materials for sliding contact applications in liquid nitrogen because

wear and friction are lower than the reference material (which has been used successfully for bearing cages).

(3) The friction coefficient of the 304 stainless-steel riders on the polymer laminates was similar in both liquid nitrogen and liquid hydrogen, but rider wear was somewhat greater in liquid hydrogen. Polymer-laminate disk specimens showed deeper and rougher wear tracks in liquid hydrogen than in liquid nitrogen.

Lewis Research Center,
National Aeronautics and Space Administration,
Cleveland, Ohio, December 13, 1967,
129-03-13-01-22.

REFERENCES

1. Bisson, Edmond E.; and Anderson, William J.: Advanced Bearing Technology. NASA SP-38, 1964.
2. Scott, Russell B.: Cryogenic Engineering. D. Van Nostrand Co., Inc., 1959.
3. Powers, J. V., Jr.: A Rotatable Sealing Coupling for Cryogenic Uses. Advances in Cryogenic Engineering. Vol. 10. K. D. Timmerhaus, ed., Plenum Press, 1965, pp. 458-463.
4. Chamberlain, D. W.: Mechanical Properties Testing of Plastic Laminate Materials Down to 20° K. Advances in Cryogenic Engineering. Vol. 10. K. D. Timmerhaus, ed., Plenum Press, 1965, pp. 117-125.
5. Butner, M. F.; and Rosenberg, J. C.: Lubrication of Bearings with Rocket Propellants. Lubr. Eng., vol. 18, no. 1, Jan. 1962, pp. 17-24.
6. Wilson, W. A.; Martin, K. B.; Brennan, J. A.; and Birmingham, B. W.: Evaluation of Ball Bearing Separator Materials Operating Submerged in Liquid Nitrogen. Trans. ASLE, vol. 4, no. 1, Apr. 1961, pp. 50-58.
7. Scibbe, Herbert W.; and Anderson, William J.: Evaluation of Ball-Bearing Performance in Liquid Hydrogen at DN Values to 1.6 Million. Trans. ASLE, vol. 5, no. 1, Apr. 1962, pp. 220-232.
8. Wisander, D. W.; Hady, W. F.; and Johnson, R. L.: Friction Studies of Various Materials in Liquid Nitrogen. NACA TN 4211, 1958.

9. Wisander, Donald W.; Maley, Charles E.; and Johnson, Robert L.: Wear and Friction of Filled Polytetrafluoroethylene Compositions in Liquid Nitrogen. Trans. ASLE, vol. 2, no. 1, Apr. 1959, pp. 58-66.
10. Mitchell, D. C.; and Pratt, G.: Friction, Wear and Physical Properties of Some Filled P. T. F. E. Bearing Materials. Conference on Lubrication and Wear, Institution of Mechanical Engineers, London, Oct. 1-3, 1957, Paper 101.
11. Buckley, Donald H.: Friction and Wear Characteristics of Polyimide and Filled Polyimide Compositions in Vacuum (10^{-10} mm Hg). NASA TN D-3261, 1966.
12. Wisander, Donald W.; Ludwig, Lawrence P.; and Johnson, Robert L.: Wear and Friction of Various Polymer Laminates in Liquid Nitrogen and in Liquid Hydrogen. NASA TN D-3706, 1966.
13. Duffin, Daniel J.; and Nerzig, Charles: Laminated Plastics. Reinhold Publishing Corp., 1958.