Applied Research Laboratory

Technical Report

THE FOCUSING PROPERTIES OF AN ACOUSTIC
THIN LENS AND ZONE PLATE

by

W. J. Hughes
J. R. Craig

DISTRIBUTION STATEMENT A
Approved for public release
Distribution Unlimited

PENNSSTATE



DTIC QUALITY INSPECTED 1

The Pennsylvania State University
APPLIED RESEARCH LABORATORY
P.O. Box 30
State College, PA 16804

**THE FOCUSING PROPERTIES OF AN ACOUSTIC
THIN LENS AND ZONE PLATE**

by

W. J. Hughes
J. R. Craig

Technical Report No. TR 96-003
April 1996

Supported by:
U.S. Navy and the NROTC program

L.R. Hettche, Director
Applied Research Laboratory

19960506 168

Approved for public release; distribution unlimited

DTIC QUALITY INSPECTED 1

TABLE OF CONTENTS

LIST OF FIGURES

Chapter 1. INTRODUCTION	1
Chapter 2. THE ACOUSTIC THIN LENS	2
The Basic Lens Formula	2
The Lens Makers' Equation	3
Ray Tracing Methods.....	5
Lens Power.....	6
Lens Aberrations	7
Spherical Aberration	7
Thermal Aberration	8
Thin Lens Performance	10
Chapter 3. THE ACOUSTIC ZONE PLATE	12
Introduction to Diffraction	12
The Zone Plate Governing Equations	13
Fraunhofer Diffraction	13
Fresnel Diffraction	17
The Fresnel Zone Plate	20
Zone Plate Aberrations	22
Spherical Aberration	22
Off-axis Aberration	23
Fresnel Zone Plate Performance	24
Chapter 4. SUMMARY AND COMPARISON	26
REFERENCES	29
APPENDIX A. THIN LENS DESIGN	30
APPENDIX B. ZONE PLATE DESIGN	32

LIST OF FIGURES

1. Basic Thin Lens Geometry	3
2. Graphical Ray Tracing	5
3. Theoretical Directional Response of a 1 MHz Polystyrene Lens	10
4. Axial Pressure Distribution of a 1 MHz Polystyrene Lens	11
5. The Fresnel Zone Plate	13
6. Basic Geometry for Fraunhofer Diffraction	14
7. Bessel Function of First Order	16
8. Geometry for Fresnel Diffraction	17
9. The Fresnel Zone Plate Geometry	21
10. Off-axis Aberration	23
11. Axial Pressure Distribution of a 20 Zone, 19.2 cm Diameter, 1 MHz Zone Plate	25
12. Directional Response of a 20 Zone, 19.2 cm Diameter, 1 MHz Zone Plate	25
13. Relative Pressure Response of a 1 Mhz Ideal Thin Lens and Fresnel Zone Plate	27
14. Axial Pressure Distribution for a 1 Mhz Ideal Thin Lens and Fresnel Zone Plate	28

Chapter 1

INTRODUCTION

Underwater visual imaging is often restricted to very short range by suspended organic material and particles such as sand and silt stirred up from the bottom. In this highly turbid environment the use of video imaging becomes impossible because these suspensions significantly scatter light. Ultrasonic waves have longer wavelengths and therefore much less scatter. The necessity for divers to "see" in this environment for salvage and rescue operations and military applications expresses the need for an acoustic imaging device.

For such an imaging system to be effective several factors must be incorporated into the potential design. Real time operation at ranges of up to ten meters, good resolution, and a large field of view are all desired. The equipment must be lightweight out of water and as close to neutrally buoyant as possible. The design should be as simple as possible and obviously must be capable of operation at submergence pressure.

To meet the demand of simplicity, light weight, and good resolution, an acoustic thin lens and a zone plate will be developed and compared for use as a beamformer. A thin lens forms beams by inserting a spatially dependent time delay as the wavefront passes through. Correctly shaping the lens will insert the proper time delays to form a clear image. The lens will also be used to focus the transmit beams and thus eliminate most of the expensive and complex beamforming electronics of the imaging system. The Fresnel zone plate uses diffraction principles to form an image. This paper presents a survey of the design parameters of thin lenses and zone plates.

Chapter 2

THE ACOUSTIC THIN LENS

A thin lens is defined as one that has thickness very small compared to the object or image distances. There are several parameters, or "degrees of freedom", that must be determined when designing a lens for a specific application. The radii of curvature of the surfaces, the types of materials to use and their indices of refraction, the diameter, the thickness desired, and the focal length that can be tolerated are all parameters that may be varied to obtain the desired lens performance.

An additional requirement for this application is size and weight. It is always desirable to be as lightweight and as small as possible. The complete design must be as close to neutrally buoyant as possible. This puts some limitations on the materials that can be used.

The Basic Thin Lens Formula

The formation of an image by a converging lens is based on the principle that sound will obey the law of refraction, Snell's Law, which is given by:

$$n_1 \sin \theta_1 = n_2 \sin \theta_2 \quad , \quad (1)$$

where n is the index of refraction,

θ is the angle of incidence as measured from the lens axis,

and the subscripts are for the first and second media.

As a plane wave passes through a converging lens, the rays are bent toward the axis of the lens. At some distance, f , called the focal length, the rays will converge on the

axis at a focal point. Ideally, if the plane wave is placed on an angle θ to the axis, the rays will focus at a point that is on the same plane (the focal plane) as the original focal point perpendicular to the lens' axis.

The Lens Makers' Equation

To determine the radius of curvature for the two surfaces required to produce a desired focal length, the index of refraction of the material must be known. These "degrees of freedom" must be combined into a form that can be used to design and create a lens. The geometry of the basic thin lens problem is shown in Figure 1. The refractive indices of the three materials are n_1 , n_2 , and n_3 .

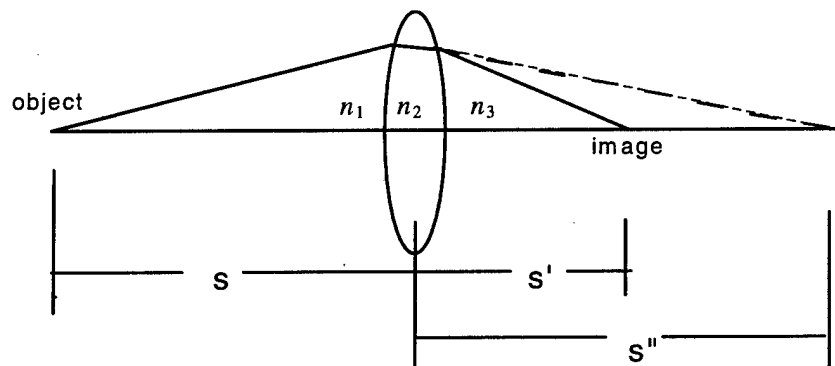

Figure 1. Basic Thin Lens Geometry

A ray leaving the object is incident on the first surface and refracts according to the following equation for spherical surfaces⁴ :

$$\frac{n_1}{s} + \frac{n_2}{s''} = \frac{n_2 - n_1}{r} \quad , \quad (2)$$

where s is the object distance,

s'' is the image distance to the center of the lens,

and r is the radius of the spherical surface.

The ray then strikes the second surface of the thin lens and is again refracted and directed toward a new image point. For our geometry, the thickness of the lens is negligible compared to the object and image distances. Therefore combining these equations, we obtain:

$$\frac{n_1}{s} + \frac{n_3}{s'} = \frac{n_2 - n_1}{r_1} + \frac{n_3 - n_2}{r_2} \quad , \quad (3)$$

where r_1 is the radius of the first surface and r_2 is the radius of the second surface.

This is a general equation that the lens maker can use for a thin lens with different media on each side. This equation can be simplified if the medium on both sides of the lens is the same:

$$\frac{n_1}{s} + \frac{n_1}{s'} = (n_2 - n_1) \left(\frac{1}{r_1} + \frac{1}{r_2} \right) \quad , \quad (4)$$

When the surrounding medium is water ($n_1=1$), the familiar lens makers' formula is obtained:

$$\frac{1}{f} = (n-1) \left(\frac{1}{r_1} - \frac{1}{r_2} \right) , \quad (5)$$

where f is the focal length.

By convention⁴, when a wave is traveling to the right, all convex surfaces encountered are considered positive radii and all concave surfaces are of negative radii.

Ray Tracing Methods

Graphical ray tracing can be used for rapid assessment where extreme accuracy is not required.⁶ Basic graphical ray tracing is done by drawing concentric circles, shown in figure 2a, with radii proportional to the indices of refraction of the materials used. Figure 2b shows an example of graphical ray tracing with a spherical lens surface.

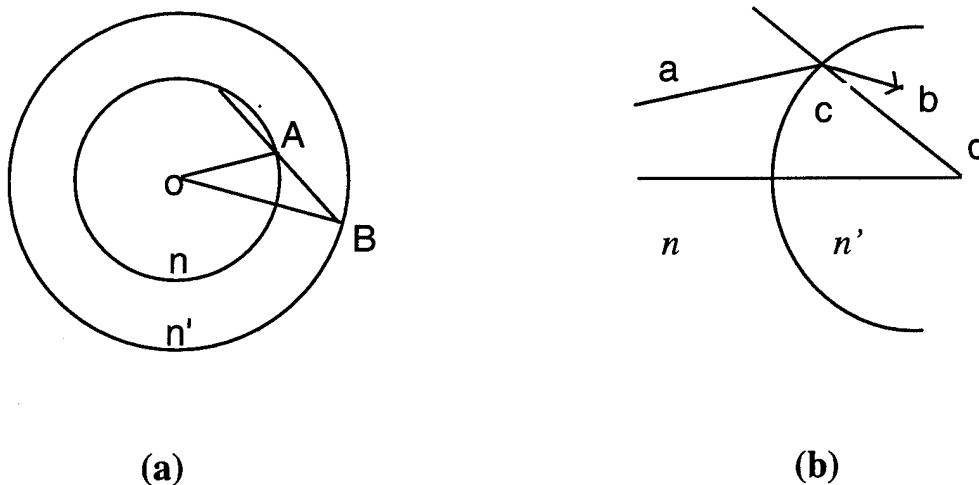

Figure 2. Graphical Ray Tracing

In figure 2b, the incident ray, a, is drawn to intercept the lens surface at point c. In figure 2a, a line is drawn, parallel to line 'a' in figure 2b, from the center of the concentric circles, point O, to the circle corresponding to the medium which contains the incident ray, labeled A. Next a line parallel to the radius of the lens surface, line c-d, is drawn through point A. The point where this line intersects the circle of the second medium is labeled B. The line OB in figure 2a, is the direction of the refracted ray, b, in figure 2b. This procedure is repeated at each surface until the ray is projected onto the final image plane. This is a good first check of the system.

When greater accuracy is required, trigonometric ray tracing is used. For spherical surfaces, the path of a meridional ray can be shown quite accurately. This method is used in several computer programs. Kingslake⁷ explains this procedure in detail.

Lens Power

The power of a thin lens is the sum of the power of the lens surfaces. The power for a thin lens is:

$$\text{Power} = \frac{1}{f} = (n - 1) \left(\frac{1}{r_1} - \frac{1}{r_2} \right) , \quad (6)$$

and for a system of lenses,

$$\text{Power} = \sum \frac{1}{f} . \quad (7)$$

Lens Aberrations

Spherical Aberration

When a plane wave is incident on a thin lens, parallel rays can be traced from all points on that lens. It can be shown that all of the rays do not focus exactly at a single point. This image problem is known as spherical aberration and can be expressed as:⁹

$$S \cong -h^2 / 2R^2 \left(\frac{n_1}{n_2} \right)^2 f \quad , \quad (8)$$

where n_1 and n_2 are for the object and image side respectively, and h is the height of incidence.

There are several different methods to keep spherical aberration to a minimum. First, the shape of the lens can be altered or "bent". Bending the lens requires that the lens power and therefore the focal length remains constant. From equation (6), this restriction requires that $\left(\frac{1}{r_1} - \frac{1}{r_2} \right)$ remains constant.

A dimensionless shape parameter is then defined as:⁶

$$q = \frac{r_2 + r_1}{r_2 - r_1} \quad . \quad (9)$$

Equation (9) can be used to plot shape factor vs. axial difference in focal length. This plot is typically parabolic in shape and therefore has a minimum which corresponds to the minimum spherical aberration. Spherical aberration may also be corrected by the use of multiple surfaces of different refraction index.

Temperature Dependence of Index of Refraction (Thermal Aberration)

The ultrasonic index of refraction is the ratio of the speed of sound in water to the speed of sound in the material. Since this relationship involves the speed of sound it is temperature dependent. For optical glasses, this temperature coefficient is very small, but for plastics and liquids, it can be quite large. This can cause the image to be out of focus and must be compensated for. The thermal aberration has been treated by D.L. Folds² and is summarized below.

Both water and typical plastic lens materials have relatively large values of thermal expansion coefficient. This makes the lens focal length highly temperature dependent. For most materials the sound velocity varies linearly in the temperature range of interest.

The sound velocity can be expressed as:

$$V = V_o + lT \quad , \quad (10)$$

where l is the thermal coefficient of sound velocity and V_o is the velocity at 0° C.

The value of l is in the range -1 to -9 m/sec °C for the solids and about 4 m/sec °C for water. The index of refraction for the material can then be expressed by:

$$n = n_o + bT \quad , \quad (11)$$

where

$$b \cong n_o \frac{(4 - l n_o)}{C_o} \quad . \quad (12)$$

Combining equations (5) and (11), the variation of focal length with temperature, which is our point of concern, is then expressed by :

$$\frac{df}{dT} = -fn_o \frac{(4 - l n_o)}{C_o(n-1)} \quad (13)$$

The axial pressure amplitude response for circular aperture has been shown to be the familiar sinc function relationship², specifically:

$$A_R = 20 \log|\text{sinc}(\pi g x)| \quad , \quad (14)$$

where

$$g = \left(\frac{D}{\lambda}\right) [8F_N(x+f)]^{-1} \quad . \quad (15)$$

In this equation F_N is the lens f/number and x is the axial distance from the focal point.

Forcing the Strehl² focusing condition that A_R remains greater than 0.5 dB below the maximum response level, the depth of focus can then be expressed as:

$$\Delta F = \frac{3F_N f}{D/\lambda} \quad . \quad (16)$$

Therefore the temperature range over which acceptable focusing will exist is:

$$\Delta T = \frac{\Delta F}{df/dT} = \left(\frac{3F_N}{D/\lambda}\right) \left[\frac{C_o(n-1)}{n_o(4-n_o l)} \right] \quad . \quad (17)$$

This equation can now be used to determine an acceptable temperature range for the lens.

Thin Lens Performance

The measure of thin lens performance is its directional response at the focal plane and its depth of focus. Axial pressure distribution establishes the depth of focus so it is common to plot both the axial pressure distribution and the focal plane pressure distribution. For the current application, a theoretical thin lens was designed using polystyrene and the following prescription: $r_1 = -25$ cm, $r_2 = 18.92$ cm, center thickness of 1 cm and $D = 17.5$ cm. The lens equation, equation (5), determines a focal length of 30 cm at 20° C for this lens. Figure 3 shows the theoretical directional response at 1 MHz at the focal length. The beamwidth is near the 0.8 degrees (which correlates to about 0.4 cm at the 30 cm focal length) expected for 1 MHz and a 17.5 cm diameter lens.

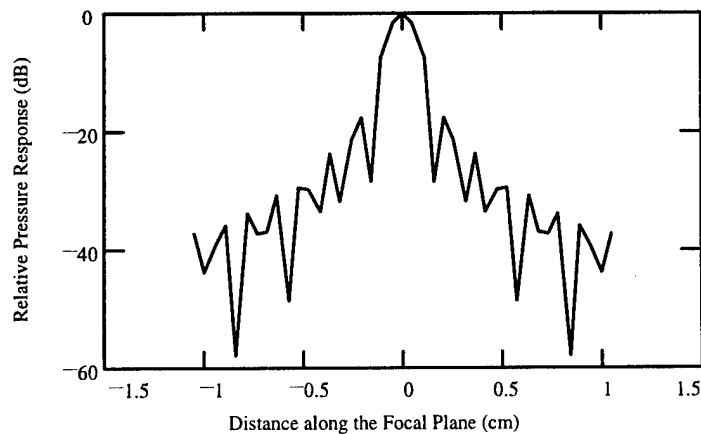

Figure 3. Theoretical Directional Response for a 1 MHz Polystyrene Lens

The other key parameter in lens performance is depth of focus. The depth of focus is predicted to be about 3 cm by equation (16). Figure 4 shows the theoretical axial pressure distribution.

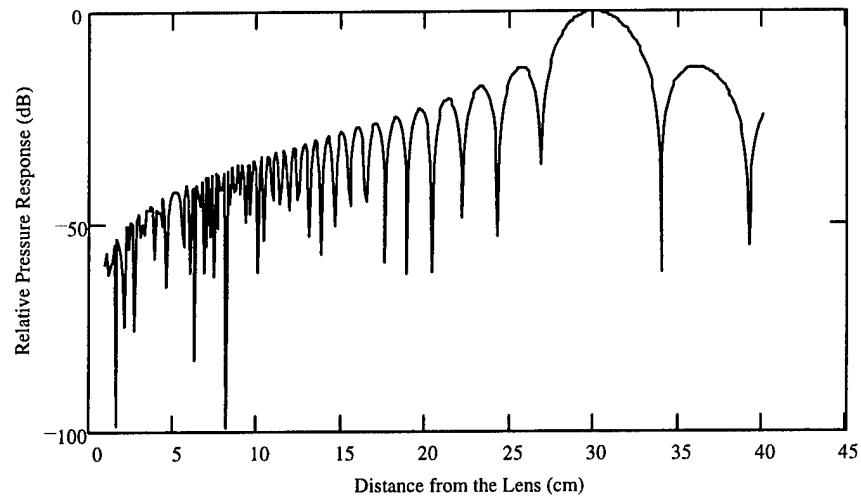

Figure 4. Pressure Amplitude (dB) vs. Axial Distance from the Lens (cm)
for a 1 MHz Polystyrene Lens

Chapter 3

THE ACOUSTIC ZONE PLATE

Introduction to Diffraction

As with light, sound also deviates from straight line propagation when passing the edge of an obstacle. This phenomenon is called diffraction and can be explained using wave theory. There are two general classifications of diffraction. If the source and observation points are so far from the diffracting aperture that lines drawn from the source or observation points to the center and edge of the aperture do not differ in length by more than a small fraction of a wavelength, then it can be treated as Fraunhofer diffraction. If this is not the case, then it is Fresnel diffraction.¹¹ While there is no exact wavelength defined, a typical cutoff is one twentieth of a wavelength.

We can use diffraction principles to create a focusing effect using a Fresnel zone plate, shown in figure 5. Each zone has a specific radius to develop this focusing effect using diffraction. A Fresnel zone plate was designed using the same operating frequency, 1MHz, as the thin lens designed in chapter 2. It contains 20 zones and has a diameter of 19.2 centimeters.

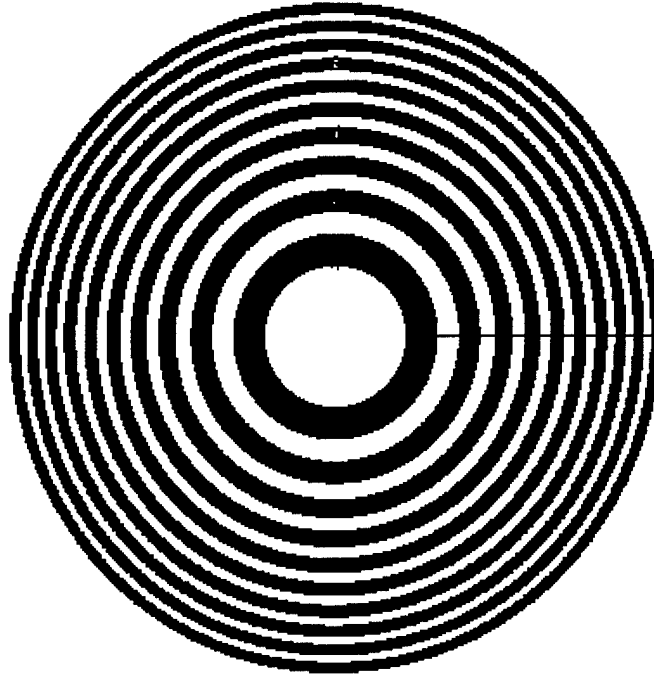

Figure 5. A 1 MHz, 20 Zone, Fresnel Zone Plate

The Zone Plate Governing Equations

Fraunhofer Diffraction

For circular aperture with normal incidence, the Fraunhofer diffraction pattern is axisymmetric. If the variation of the pattern along one radius of the observation plane can be determined then the rest of the axial patterns are known. The basic geometry is shown in figure 6.

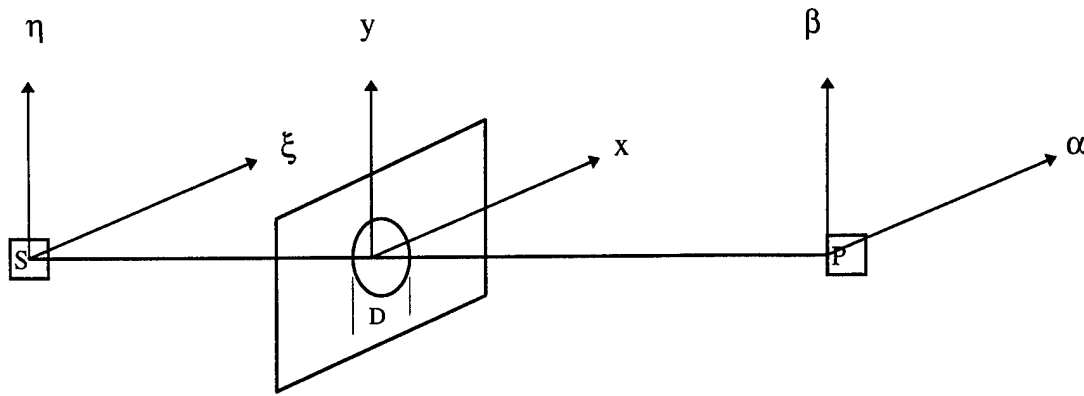

Figure 6. Basic Geometry for Fraunhofer Diffraction

Since we have determined that the pattern is symmetrical, we need only determine the pattern along the α axis. It can be shown¹¹ that the amplitude function at point P, $U_o(P)$, is determined by:

$$U_o(P) = U_o(\alpha_o, \beta_o) Q(P) \quad , \quad (18)$$

where

$$Q(P) = \frac{4}{\pi D^2} \iint_{\sigma} \exp(-ikx \sin \theta_2) dx dy \quad , \quad (19)$$

and the double integration is over the aperture, σ .

Letting x be constant for the moment, the corresponding limits of y are:

$$y_{\text{limit}} = \pm \sqrt{\frac{D^2}{4} - x^2} \quad , \quad (20)$$

and the integration with respect to y yields:

$$\int dy = 2\sqrt{\frac{D^2}{4} - x^2} \quad . \quad (21)$$

For simplification we then make the substitution:

$$\mu = \frac{kD}{2\pi} \sin \theta_2 \quad . \quad (22)$$

This leads to:

$$Q(P) = \frac{4}{\pi D^2} \int_{-D/2}^{D/2} 2 \left(\frac{D^2}{4} - x^2 \right)^{1/2} \exp \left[-i \frac{2\pi}{D} \mu x \right] dx \quad (23)$$

If we let the integration variable be:

$$\tau = 2x/D \quad , \quad (24)$$

then

$$x = D\tau/2 \quad , \quad (25)$$

and

$$dx = (D/2)d\tau \quad , \quad (26)$$

at a distance of $x = D/2$, the integration variable, $\tau = 1$.

Now,

$$Q(P) = \frac{2}{\pi} \int_{-1}^1 (1 - \tau^2)^{1/2} \exp[-i\pi\mu\tau] d\tau \quad (27)$$

Dividing the integral into two separate integrals from -1 to 0, and from 0 to 1, we see that the value of $(1 - \tau^2)$ is the same for both and the sign is changed in the exponential.

Therefore adding the exponentials yields $2 \cos(\pi\mu\tau)$, a real quantity. Combining and integrating we obtain the familiar first order Bessel function,

$$Q(P) = \frac{2J_1(\pi\mu)}{\pi\mu} \quad \mu \geq 0 \quad . \quad (28)$$

This function is plotted in figure 7. Since this pattern is symmetrical, the overall amplitude pattern is a set of concentric rings around the given origin.

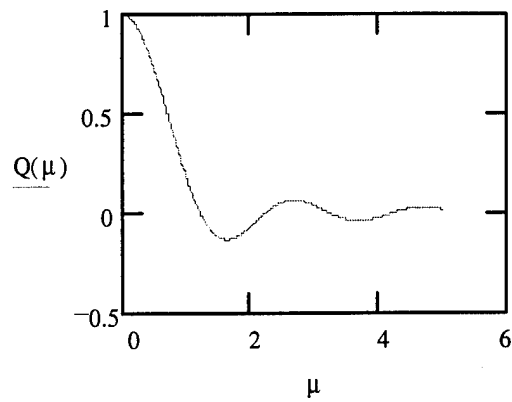

Figure 7. Bessel Function of First Order

The amplitude is a maximum where $\mu=0$. This value, μ , is related to radius. If the radius is r , then $r = l \tan \theta_2$ and since we are under the assumption of Fraunhofer diffraction, we have:

$$\tan \theta_2 = \sin \theta_2 \quad , \quad (29)$$

$$\mu = \frac{kD}{2\pi} \sin \theta_2 \quad , \quad (30)$$

$$\mu = \frac{D}{l\lambda} r \quad . \quad (31)$$

Equation (28) was first derived and developed by G.B. Airy and is known as the Airy disk. Eighty four percent of the total energy in the pattern is generated within the central ring where:

$$r = \frac{1.22l\lambda}{D} \quad . \quad (32)$$

Fresnel Diffraction

With the need for a short focal length the distance from the diffracting plane to the observation point must be necessarily small. The assumption that the rays are parallel from the aperture to the focal point is no longer valid. Therefore Fresnel diffraction must be used. Figure 8 shows the geometry for the Fresnel diffraction.

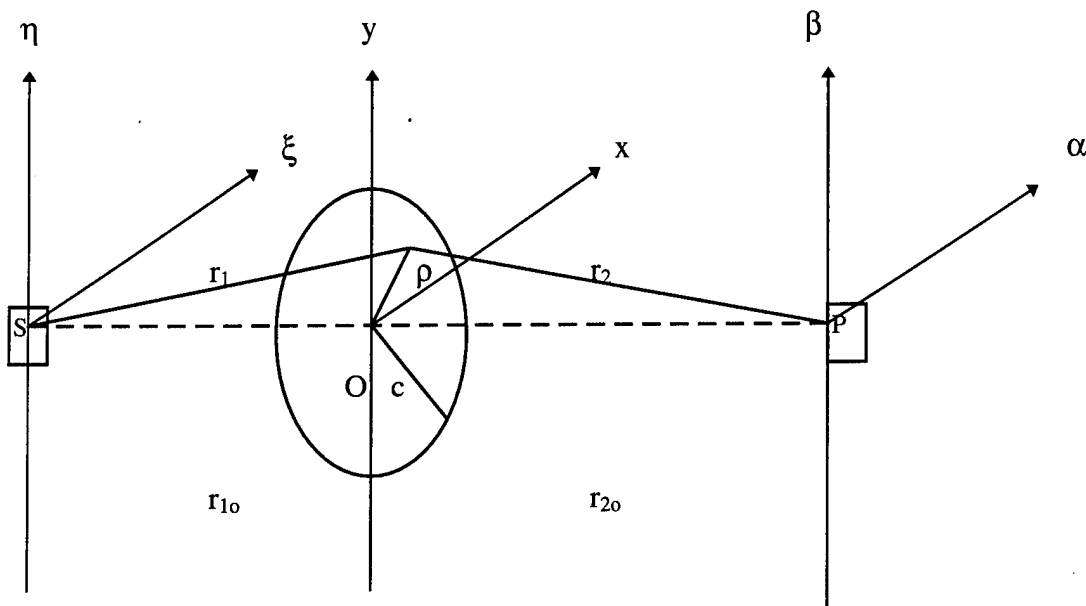

Figure 8. Geometry for Fresnel Diffraction

Since the diffracting surface is circular we can take a ring shaped element $2\pi\rho d\rho$, and integrate between $\rho=0$ and $\rho=c$. This leads to the Kirchoff integral in the form:

$$U_o(P) = \frac{-iA}{\lambda r_{10} r_{20}} \int_0^c \exp[ik(r_1 + r_2)] 2\pi\rho d\rho \quad (33)$$

From the geometry,

$$r_1^2 = r_{1o}^2 + \rho^2 \text{ and } r_2^2 = r_{2o}^2 + \rho^2.$$

Since r_{1o} and r_{2o} are constants, differentiating and dividing equation (33) by 2 gives

$$\rho d\rho = r_1 dr_1 = r_2 dr_2.$$

Therefore,

$$dr_1 = \left(\frac{1}{r_1}\right)\rho d\rho \text{ and } dr_2 = \left(\frac{1}{r_2}\right)\rho d\rho,$$

and adding we get:

$$\rho d\rho = \frac{r_1 r_2}{r_1 + r_2} d(r_1 + r_2) \quad (34)$$

Since c is small, we can make the approximation

$$\rho d\rho \cong \frac{r_{1o} r_{2o}}{r_{1o} + r_{2o}} d(r_1 + r_2) \quad (35)$$

Making the substitution, $l = r_1 + r_2$, we get

$$U_o(P) = -i \frac{2\pi A}{\lambda(r_{1o} + r_{2o})} \int_{l(0)}^{l(c)} e^{ikl} dl \quad (36)$$

The path length, l , is always slightly longer than $r_{1o} + r_{2o}$, and can be expressed as

$$l = r_{1o} + r_{2o} + \Delta \frac{\lambda}{2}, \quad (37)$$

the path length difference being expressed in half wavelengths.

Changing the integration variable,

$$dl = \lambda/2 d\Delta, \quad (38)$$

and

$$e^{ikl} = e^{ik(r_1 + r_2)} e^{i\pi\Delta}, \quad (39)$$

since

$$k\lambda = 2\pi. \quad (40)$$

The first exponential is constant and can be brought outside the integral and combined to form $U_{oo}(P)$, the amplitude of the sound with no diffracting surface present.

Taking $\lambda/2$ outside the integral we get:

$$U_o(P) = -i\pi U_{oo}(P) \int_0^{\Delta(c)} \exp(i\pi\Delta) d\Delta, \quad (41)$$

We have $\Delta=0$ at $l(0)$ and $\Delta(c)$ is when $\rho=c$.

Integrating we get:

$$U_o(P) = U_{oo}(P) \{1 - \exp[i\pi\Delta(c)]\}, \quad (42)$$

and the corresponding irradiance is:

$$I(P) = |U_o(P)|^2 = 2I_o(P) [1 - \cos(\pi\Delta(c))] = 4I_o(P) \sin^2\left(\frac{\pi}{2}\Delta(c)\right). \quad (43)$$

From equation (43), it is readily seen that $I(P)$ passes through a series of maximum and zeros as c varies. Therefore the pattern is a series of dark and light rings (fringes).

Fresnel Zone Plate

Instead of taking the integral over the whole open circle in equation (41) above, consider a zone from $\Delta=\Delta_1$ to $\Delta=\Delta_2$:

$$\begin{aligned} U_0(P) &= -i\pi U_{oo}(P) \int_{\Delta_1}^{\Delta_2} \exp(i\pi\Delta) d\Delta = U_{oo(P)} [\exp(i\pi\Delta_1) - \exp(i\pi\Delta_2)] \\ &= U_{oo}(P) [\cos \pi\Delta_1 - \cos \pi\Delta_2 + i(\sin \pi\Delta_1 - \sin \pi\Delta_2)] \end{aligned} \quad (44)$$

Now let Δ_1 be an even integer and $\Delta_2=\Delta_1+1$, is therefore odd. If we divide the complete circular aperture into such zones, the boundaries of which have Δ equal to successive integers, the corresponding radii from the center of the aperture are found by solving the equation,

$$\Delta(c) = \frac{c^2(r_{1o} + r_{2o})}{\lambda r_{1o} r_{2o}}, \quad (45)$$

for c , with $\Delta(c)$ being replaced by n ,

$$c_n = \sqrt{\frac{n\lambda r_{1o} r_{2o}}{r_{1o} + r_{2o}}}. \quad (46)$$

If we cover alternate zones with an sound opaque material, the result is a Fresnel zone plate. To be able to compare the zone plate with a regular lens, if we make r_{1o} the object distance, r_{2o} is the image distance, and the focal length of the zone plate is given by

$$\frac{1}{f} = \frac{1}{r_{1o}} + \frac{1}{r_{2o}} \quad (47)$$

The physical meaning of focal length is when the object is at an infinite distance, the image is formed at the focal length. Using this in equation (46) above leads to

$$c_n^2 = n\lambda f, \text{ or}$$

$$f = \frac{c_n^2}{n\lambda} . \quad (48)$$

This is known as a geometric zone plate.

An interferometric zone plate is more exact but more difficult in practice. As shown above, the path length difference to the focal point is in multiples of half wavelengths. From the geometry of the Fresnel zone plate, shown in Figure 9, and the condition above, $F = f + \frac{n\lambda}{2}$ and $r_n^2 = F^2 - f^2$, therefore

$$r_n = \sqrt{n\lambda f + \frac{n^2 \lambda^2}{4}} . \quad (49)$$

Typically, $f \gg n\lambda/4$ so that the geometric approximation is valid.

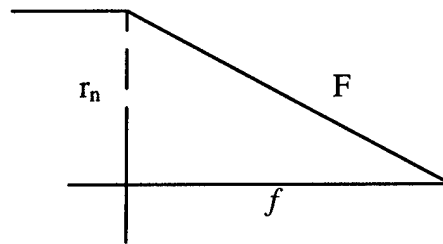

Figure 9. The Fresnel Zone Plate Geometry

Zone Plate Aberrations

Spherical Aberration

As in the thin lens, spherical aberration is present in a zone plate. If the sound path difference ($F - f$ above) is expanded in a power series the result is:

$$F - f = (f^2 + r_n^2)^{1/2} - f = \left(\frac{r_n^2}{2f} \right) - \frac{r_n^4}{8f^3} + \dots \quad (50)$$

The elimination of the $\frac{r_n^4}{8f^3}$ term leads to the geometric approximation and introduces spherical aberration. This term shows that there is some theoretical maximum number of zones that are acceptable before the spherical aberration interferes with the focus of the sound enough to be noticed. Although this aberration becomes noticeable at about 1/4 wavelength, sometimes a few wavelengths are tolerable. Taking the conservative limit of 1/4 wavelength, we can determine the maximum number of zones as follows:

$$\frac{r_n^4}{8f^3} = \frac{\lambda}{4} \quad , \quad (51)$$

and
$$r_n^2 \equiv n\lambda f \quad , \quad (52)$$

therefore,
$$\frac{n^2 \lambda^2}{8f} = \frac{\lambda}{4} \quad (53)$$

or

$$n = \sqrt{\frac{2f}{\lambda}} \quad . \quad (54)$$

Off Axis Aberration

The field of view of the zone plate is determined by the off-axis aberration. The sound path difference for the off-axis case is shown in figure 10.

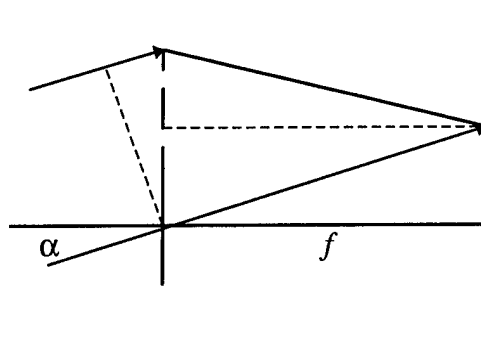

Figure 10. Off-axis Aberration

The sound path difference can be expressed by:¹⁰

$$r_n \sin \alpha + f \left[1 + \left(\tan \alpha - \frac{r_n}{f} \right)^2 \right]^{1/2} - f [1 + \tan^2 \alpha]^{1/2} \quad (55)$$

If a binomial expansion is done on the square root terms and the $\sin \alpha$ and $\tan \alpha$ are expressed as power series, the sound path difference becomes:

$$\frac{r_n^2}{2f} - \frac{r_n^4}{8f^3} + \frac{r_n^3 \alpha}{2f^2} - \frac{3r_n^2 \alpha^2}{4f} \quad , \quad (56)$$

where the higher order terms have been dropped.

From equation (48) and (49), the first two terms are equal to $n\lambda/2$ so the third and fourth terms are the off-axis aberration. As before, the aberration becomes apparent when the sum of the terms becomes $\lambda/4$. If the zone plate has only a few terms (n is small), the angle can be made large and only the fourth term will be significant. Setting this term equal to $\lambda/4$, the field of view becomes

$$\alpha = (3n)^{-1/2} \quad . \quad (57)$$

If the number of zones is large the third term dominates and the field of view becomes:

$$\alpha = \left(\frac{n\lambda}{f} \right)^{-1/2} \left(\frac{1}{2n} \right) \quad . \quad (58)$$

Fresnel Zone Plate Performance

For comparison, a theoretical design was created for a Fresnel zone plate using the same criteria as the thin lens of Chapter 2. With a focal length of 30 cm and a frequency of operation of 1 MHz, a Fresnel zone plate will have twenty zones with the radii determined by equation (49). Such a zone plate is illustrated in Figure 5.

As with the thin lens, depth of focus is a significant concern. Figure 11 shows the theoretical axial pressure distribution for the designed zone plate. The peak pressure is at the focal point of 30 cm as expected. The first side lobes are down at least 15 dB and the depth of focus at the 3 dB down points is about 3 cm, as predicted. Figure 12 is the focal plane pressure distribution for the zone plate. The beamwidth at the 3 dB down points is approximately 0.2 cm at the focal point and the first side lobes are down about 18 dB.

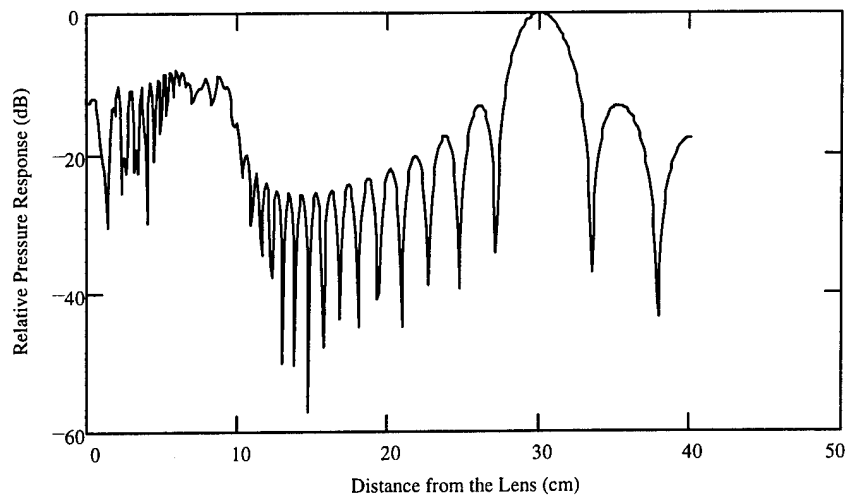

Figure 11. Axial Pressure Distribution for a 20 Zone, 19.2 cm Diameter, 1 MHz Zone Plate

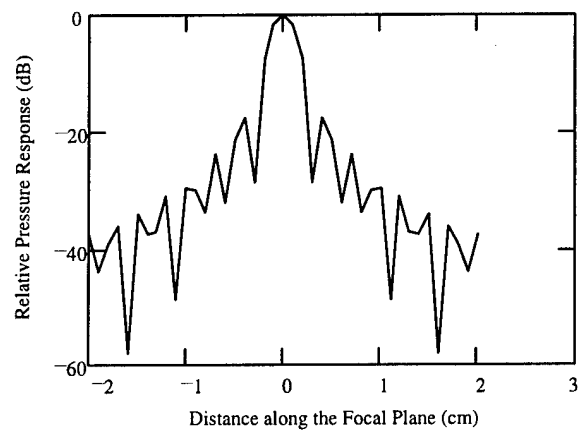

Figure 12. Directional Response of a 20 Zone, 19.2 cm Diameter, 1MHz Zone Plate

Chapter 4

SUMMARY AND COMPARISON

An acoustic lens provides an inexpensive way to focus a projected beam and then focus the return over a large field of view. The images are not degraded by suspended mud, sand, or silt. The methods of optical design can be used for ultrasonic lenses and zone plates and the frequency chosen will depend on the range, concentration of suspended particles, and the resolution. In addition, a lens with low spherical aberration and acceptable temperature insensitivity can be designed using only spherical surfaces, which are easily manufactured to close tolerance.

The choices of materials for lenses are vast and some inexpensive and easily manufactured materials have been used.^{1,2,3} Polystyrene was chosen because it has a good impedance match with seawater, an index of refraction lower than water, a low insertion loss, and good physical characteristics for a lens. Optical lens design programs have been developed and can be used to refine a lens design for ultrasonic use. Other lens configurations such as the liquid filled, spherical shell¹ have proven to be excellent beamformers.

The zone plate is a little more difficult from a manufacturing standpoint but has some of the qualities necessary for a good imaging system. The major problem will be to find a good choice for a material that is "opaque" to sound. Most of the common anechoic materials have some transmission. A reasonable design, using the same parameters as the lens above, was developed for comparison purposes.

Figure 13 compares the theoretical pressure distributions for a 1 MHz ideal polystyrene lens and a 1 MHz Fresnel zone plate. The thin lens is a slightly better performer than the zone plate as it has a slightly narrower beamwidth.

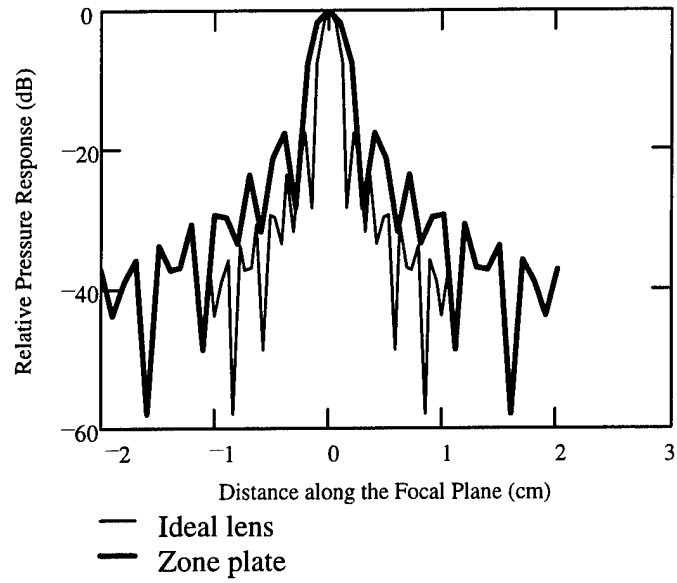

Figure 13. Relative Pressure Response of a 1 MHz Ideal Thin Lens and Fresnel Zone Plate

Figure 14 compares the depth of focus for a thin lens and zone plate. Again the thin lens is a slightly better performer at this frequency. The zone plate may have application in higher frequency applications, such as medical imaging, where the zone plate can be made smaller and the focal lengths are much shorter.

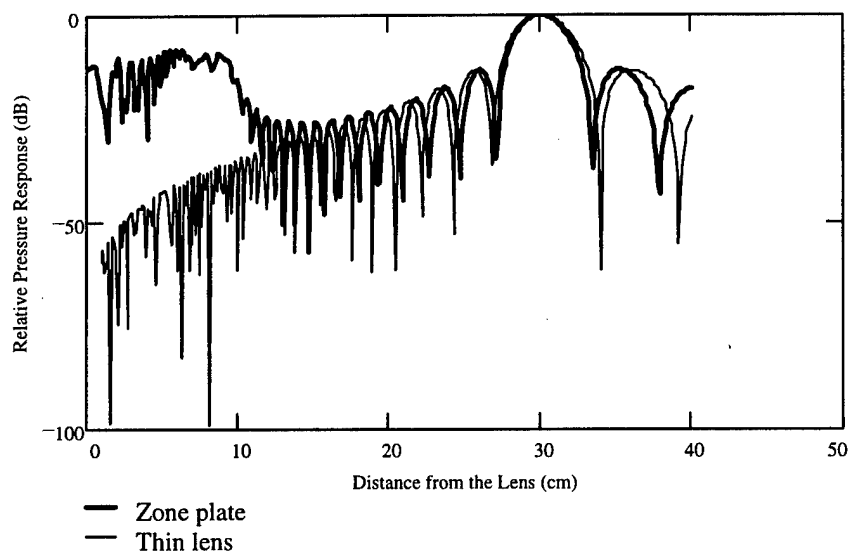

Figure 14. Axial Pressure Distribution for a 1 Mhz Ideal Thin Lens and Fresnel Zone Plate

BIBLIOGRAPHY

1. Belcher, E.O., "A Multibeam, Diver-Held Sonar using a Liquid-Filled, Spherical Acoustic Lens", Proceedings of the IEEE, 1993.
2. Folds, D. L., "Focusing properties of solid ultrasonic cylindrical lenses", J. Acoust. Soc. Am., Vol. 53, 826-834, 1973.
3. Folds, D. L., "Focusing properties of a solid four element ultrasonic lens", J. Acoust. Soc. Am., Vol. 58(1), 72-77, July 1975.
4. Jenkins, F.A. and White, H.E., Fundamentals of Optics, New York: McGraw Hill, 1957.
5. Jones, C.H. and Gilmour, G.A., "Sonic cameras", J. Acoust. Soc. Am., Vol. 59(1), 74-84, January 1976.
6. Kingslake, R. Lens Design Fundamentals, New York: Academic Press, 1978
7. Laikin, M. Lens Design, (Marcel Dekker, Inc., 1991)
8. Pierce, A. D. Acoustics: An Introduction to Its Physical Principles and Applications (McGraw-Hill, New York, 1981)
9. Tannaka, Y. and Koshikawa, T. "Solid-liquid compound hydroacoustic lens of low aberration", J. Acoust. Soc. Am., Vol. 53(2), 590-595, 1973.
10. Young, M. J. Optical Soc. Am., Vol. 62(8), 972-976, August 1972.
11. Yu, Francis T. Introduction to Diffraction, Information Processing, and Holography (The MIT Press, Cambridge, Massachusetts, and London, England, 1973)

For a thin lens, the pressure distribution in the focal plane is determined as follows:

1. $x := -2, -1.9..2$ First define a range along the focal plane
2. $c := 15000$ cm/sec Value for the speed of sound
3. $F := 1 \cdot 10^6$ Hz Design frequency
4. $\lambda := \frac{c}{F}$ Define the wavelength you are using
5. $D := 17.5$ cm
 $f := 30$ cm Define the lens diameter and focal length
4. $P(x) := \frac{2 \cdot J_1\left(\frac{\pi}{\lambda \cdot f} \cdot D \cdot x\right)}{\frac{\pi}{\lambda \cdot f} \cdot D \cdot x}$ Equation for focal plane pressure
5. $A(x) := 20 \cdot \log(P(x))$ Convert to decibels

6. Plot

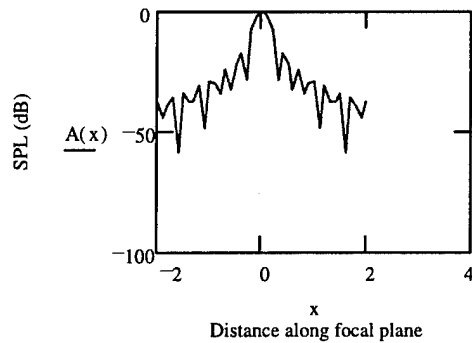

Appendix B ZONE PLATE DESIGN

This Appendix is an easy to use "cookbook" method for determination of approximate pressure distributions along the axis and in the focal plane of a Fresnel zone plate.

The pressure distribution along the axis of the zone plate is determined as follows:

1. $z := 0, .1..40$ Define a desired range

2. $ua(z) := \sqrt{r(n)^2 + z^2}$ Define a range of values of distance from the radii
to
the axis

$$ub(z) := \sqrt{t(n)^2 + z^2}$$

3. $P_j(z) := 20 \log \left| \frac{\sum_n (j \sin(k \cdot ub(z)) - j \sin(k \cdot ua(z)) - \cos(k \cdot ub(z)) + \cos(k \cdot ua(z)))}{20} \right|$

Plot

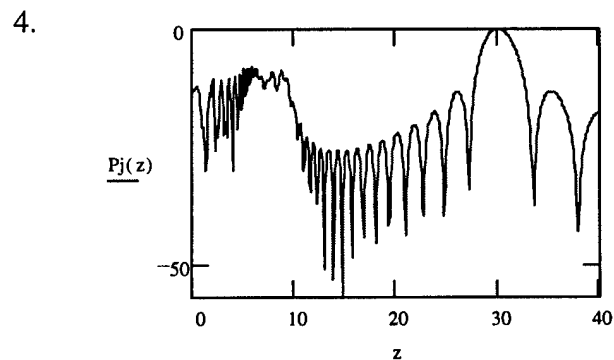

For the zone plate the pressure distribution is determined as follows:

1. $x := -2, -1.9..2$ First define a range along the focal plane
2. $n := 1, 3..19$ $m(n) := n + 1$ Define the number of zones (even and odd)

3.
$$r(n) := \sqrt{n \cdot \lambda \cdot f + \frac{n^2 \cdot \lambda^2}{4}}$$
 Determine the radius of each zone

$$t(n) := \sqrt{m(n) \cdot \lambda \cdot f + \frac{m(n)^2 \cdot \lambda^2}{4}}$$

4. $j := \sqrt{-1}$ $k := 2 \cdot \frac{\pi}{\lambda}$ Define wavenumber

5. $R(n) := \sqrt{f^2 + (r(n) - x)^2}$ Define a distance vector

6.
$$P(x) := \int_0^{2 \cdot \pi} \int_{r(n)}^{t(n)} \frac{\exp(j \cdot k \cdot R(n))}{j \cdot k \cdot R(n)} \cdot r \, dr \, d\phi$$
 Pressure equation

7.
$$A(x) := 20 \cdot \log \left[\frac{\sum_n \exp(j \cdot k \cdot R(n)) \cdot (t(n)^2 - r(n)^2) \cdot \frac{\pi}{(j \cdot (k \cdot R(n)))}}{.112637} \right]$$
 SPL conversion

8. Plot

