

Report No. CG-D-04-96

Ohmsett Tests of:

LANCER INFLATABLE BARGE

**Michael Goodwin
David S. DeVitis
Susan L. Cunneff
Donald L. Backer
Roland L. Custer
Scott McHugh**

MAR, Incorporated
6110 Executive Boulevard, Suite 410
Rockville, Maryland 20852

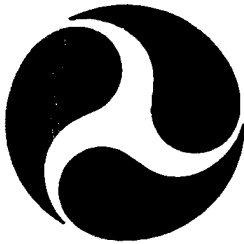

**FINAL REPORT
April 1995**

This document is available to the U.S. public through the
National Technical Information Service, Springfield, Virginia 22161

Prepared for:

U.S. Coast Guard
Research and Development Center
1082 Shennecossett Road
Groton, Connecticut 06340-6096

and

U.S. Department of Transportation
United States Coast Guard
Office of Engineering, Logistics, and Development
Washington, DC 20593-0001

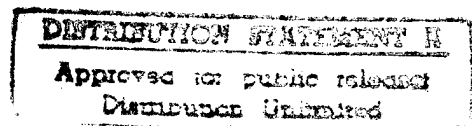

19960508 142

DTIC QUALITY INSPECTED 1

DISCLAIMER NOTICE

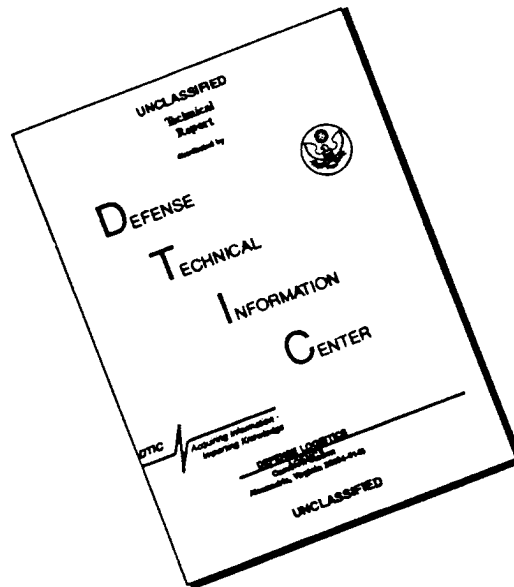

THIS DOCUMENT IS BEST QUALITY AVAILABLE. THE COPY FURNISHED TO DTIC CONTAINED A SIGNIFICANT NUMBER OF PAGES WHICH DO NOT REPRODUCE LEGIBLY.

NOTICE

This document is disseminated under the sponsorship of the Department of Transportation in the interest of information exchange. The United States Government assumes no liability for its contents or use thereof.

The United States Government does not endorse products or manufacturers. Trade or manufacturers' names appear herein solely because they are considered essential to the object of this report.

The contents of this report reflect the views of the Coast Guard Research & Development Center. This report does not constitute a standard, specification, or regulation.



G. T. Gunther
Technical Director, Acting
United States Coast Guard
Research & Development Center
1082 Shennecossett Road
Groton, CT 06340-6096

METRIC CONVERSION FACTORS

Approximate Conversions to Metric Measures

Symbol	When You Know	Multiply By	To Find	Symbol
LENGTH				
in	inches	* 2.5	centimeters	cm
ft	feet	30	centimeters	cm
yd	yards	0.9	meters	m
mi	miles	1.6	kilometers	km
AREA				
in ²	square inches	6.5	square centimeters	cm ²
ft ²	square feet	0.09	square meters	m ²
yd ²	square yards	0.8	square meters	m ²
mi ²	square miles	2.6	square kilometers	km ²
	acres	0.4	hectares	ha
MASS (WEIGHT)				
oz	ounces	28	grams	g
lb	pounds	0.45	kilograms	kg
	short tons (2000 lb)	0.9	tonnes	t
VOLUME				
tsp	teaspoons	5	milliliters	ml
tbsp	tablespoons	15	milliliters	ml
fl oz	fluid ounces	30	milliliters	ml
c	cups	0.24	liters	l
pt	pints	0.47	liters	l
qt	quarts	0.95	liters	l
gal	gallons	3.8	liters	l
ft ³	cubic feet	0.03	cubic meters	m ³
yd ³	cubic yards	0.76	cubic meters	m ³
TEMPERATURE (EXACT)				
°F	Fahrenheit temperature	5/9 (after subtracting 32)	Celsius temperature	°C

* 1 in = 2.54 (exactly).

Approximate Conversions from Metric Measures

Symbol	When You Know	Multiply By	To Find	Symbol
LENGTH				
mm	millimeters	0.04	inches	in
cm	centimeters	0.4	inches	in
m	meters	3.3	feet	ft
m	meters	1.1	yards	yd
km	kilometers	0.6	miles	mi
AREA				
cm ²	square centimeters	0.16	square inches	in ²
m ²	square meters	1.2	square yards	yd ²
km ²	square kilometers	0.4	square miles	mi ²
ha	hectares (10,000 m ²)	2.5	acres	
MASS (WEIGHT)				
g	grams	0.035	ounces	oz
kg	kilograms	2.2	pounds	lb
t	tonnes (1000 kg)	1.1	short tons	
VOLUME				
ml	milliliters	0.03	fluid ounces	fl oz
l	liters	0.125	cups	c
l	liters	2.1	pints	pt
l	liters	1.06	quarts	qt
l	liters	0.26	gallons	gal
m ³	cubic meters	35	cubic feet	ft ³
m ³	cubic meters	1.3	cubic yards	yd ³
TEMPERATURE (EXACT)				
°C	Celsius temperature	9/5 (then add 32)	Fahrenheit temperature	°F

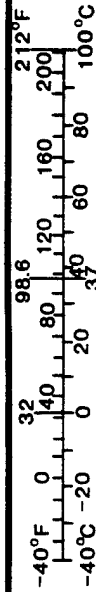

PREFACE

Ohmsett, the National Oil Spill Response Test Facility, was built in 1974 and operated by the U.S. Environmental Protection Agency until 1987. The facility was reactivated in 1992 by the U.S. Minerals Management Service, with the financial assistance of the U.S. Coast Guard and Environment Canada, in response to a need for objective, controlled testing of oil spill cleanup equipment.

This report describes tests of a model B05 Lancer Oil Recovery Barge. Lancer Inflatable Barges are manufactured in several sizes. The barge purchased for use by the National Strike Force is the model B100. This is a 100 cubic meter (27,500 gallon) barge having a length of 50.9 feet, a width of 17.9 feet and a draft of 8.1 feet. The draft of this fully loaded barge exceeds the depth of the Ohmsett basin and precludes testing the full size barge in the basin. A smaller barge had to be tested as described in this report. The B05 barge is a 5 cubic meter (1,375 gallon) barge 21.0 feet long by 7.2 feet wide. The loaded draft of the barge is 3.5 feet. The barge is equipped with a decanting hose similar to that on the B100 barge. The cover photo shows the larger B100 barge being lifted into the water. The B05 barge is similar. The barge consists of a boat shaped inflation collar having 6 compartments and an oil containment bag hanging inside the inflation collar and sealed to it.

The tests were sponsored by the U.S. Coast Guard to help define operating characteristics of the larger B100 barge. The tests measured the oil separation effectiveness of the barge, the effectiveness of the decanting hose, and the integrity of an experimental liner for the barge.

Information about testing at Ohmsett can be obtained from:

Mr. Larry Hannon
Ohmsett Project Officer
Minerals Management Service
Technology Assessment and Research Branch
HERNDON, VA 22070

Information about Lancer Oil Recovery Barges can be obtained from:

Mr. Lars Sundberg
AxTrade, Inc.
300 Atlantic Street
STAMFORD, CT 06901-3530
(203) 326-5200
(203) 326-5281 (Fax)

ACKNOWLEDGEMENTS

The financial support of The Minerals Management Service, the United States Coast Guard, and Environment Canada made possible the reactivation of the Ohmsett facility in 1992 and improvements to the oil distribution system in 1993.

Thanks to the sponsors of the Lancer test program: Larry Hannon of the Minerals Management Service and Ken Bitting of the U.S. Coast Guard Research and Development Center. Without their help these tests would not have proceeded as smoothly as they did.

Axtrade, Inc., provided the Lancer barge. Technical assistance on the Lancer was provided by Mr. Lars Sundberg of Axtrade, Inc.

Many people have contributed by conducting the tests and writing this report. The project was a team effort. All of the staff at Ohmsett contributed on a day by day basis in the testing. Besides the authors, Ohmsett staff who participated in the testing are listed alphabetically below:

Burrows H. Aumack
James Z. Butkowski
Scott McHugh
Kevin McLavish
Jim Nash
John J. Reseter
Robert A. Vitale

TABLE OF CONTENTS

Section	Page
1	INTRODUCTION 1
1.1	Purpose of the Tests 1
1.2	Background 1
1.3	Objectives of the Tests 1
1.4	Scope of the Tests 1
1.5	General Description of the Lancer Oil Recovery Barge 1
1.6	Lancer Barge Test Configuration 1
1.7	Liner for Lancer Barge 4
2	ORGANIZATION 5
3	TEST OVERVIEW AND VARIABLES 7
3.1	Overview of Tests 7
3.1.1	Oil Separation Tests 7
3.1.2	Decanting Tests 7
3.1.3	Liner Tests 7
3.2	Independent and Environmental Variables 7
3.2.1	Controlled Test Parameters (Independent Variables) 7
3.2.2	Environmental Variables 8
3.3	Measured and Calculated Dependent Variables 8
3.4	Instrumentation 8
4	DESCRIPTION OF TESTS 11
4.1	Separation Tests 11
4.1.1	Separation Tests Performed 11
4.1.2	Separation Test Description 11
4.2	Decanting Tests 12
4.2.1	Decanting Tests Performed 12
4.2.2	Decanting Test Description 12
4.3	Liner Tests 13
4.3.1	Liner Tests Performed 13
4.3.2	Liner Test Description 14
5	RESULTS AND CONCLUSIONS 15
5.1	Oil Separation Test Results 15
5.1.1	Ideal Oil/Water Interface 15
5.1.2	Oil Characteristics 15
5.1.3	Calm Water Oil Separation Test Results 17
5.1.4	Wave Characteristics 19
5.1.5	Wave Oil Separation Test Results 19
5.1.6	Off-loading Results 22
5.2	Decanting Test Results 22
5.3	Liner Test Results 23
APPENDIX A	FLUIDS TESTING A-1
APPENDIX B	INSTRUMENTATION B-1
APPENDIX C	QUALITY ASSURANCE C-1
APPENDIX D	THE OHMSETT FACILITY D-1

LIST OF FIGURES

<u>Figure</u>	<u>Description</u>	<u>Page</u>
Figure 1	Diagram of Lancer Barge	1
Figure 2	Lancer Barge Test Configuration	3
Figure 3	Fluid Sampling System Diagram	9
Figure 4	Fluid Capacity Distribution for Fully Loaded Barge	15
Figure 5	Oil Separation Test Results, 50/50 Oil/Water Mixture, Calm Water	16
Figure 6	Separation Test Results, 10/90 Oil/Water	18
Figure 7	Oil Separation Test Results in Waves & Calm Water, 50/50 Oil/Water Mixture, after 15 Minutes	19
Figure 8	Oil Separation Test Results in Waves & Calm Water, 50/50 Oil/Water Mixture, after 60 Minutes	20
Figure 9	Oil Separation Test Results in Waves & Calm Water, 10/90 Oil/Water Mixture, after 15 Minutes	21
Figure 10	Oil Separation Test Results in Waves & Calm Water, 10/90 Oil/Water Mixture, after 60 Minutes	21

LIST OF TABLES

<u>Table</u>	<u>Description</u>	<u>Page</u>
Table 1	Lancer Test Instrumentation	8
Table 2	Oil Separation Tests	11
Table 3	Decanting Tests	13
Table 4	Liner Tests	13
Table 5	Oil Separation Test Fluid Quantities	16
Table 6	Calm Water Oil Separation Test Results (50/50 Oil/Water Tests)	17
Table 7	Calm Water Oil Separation Test Results (10/90 Oil/Water Tests)	18
Table 8	Calm Water and Wave Oil Separation Test Results, 50/50 Oil/Water Tests	20
Table 9	Calm Water and Wave Oil Separation Test Results (10/90 Oil/Water Tests)	22
Table 10	Outflow Test Results	23

1 INTRODUCTION

1.1 Purpose of the Tests

The purpose of the tests described in this report was to evaluate the performance of the Lancer Oil Recovery Barge. Oil separation effectiveness, decanting ability, and the effectiveness of an experimental liner were tested.

1.2 Background

The U.S. Coast Guard is currently evaluating mechanical oil spill response equipment which have the potential to help the Coast Guard National Strike Force (NSF) effectively respond to oil spills. One of the evaluation goals is to test temporary storage devices that can be used to store recovered oil and transport it to shore for processing. This report describes tests to determine the effectiveness of one such system being used by the Coast Guard. The Lancer barge tested is a smaller size relative of the Lancer barges purchased for use with the Vessel of Opportunity Skimming System (VOSS) tested previously at Ohmsett. The larger Lancer barge could not be tested at Ohmsett because its draft was too large.

1.3 Objectives of the Tests

- o Determination of the oil separation effectiveness of the Lancer barge in calm water and waves, at rest and underway.
- o Determination of the ability to decant water from the bottom of the barge using the installed decanting hose.
- o Determination of the effectiveness of a liner for the barge.

1.4 Scope of the Tests

The Lancer barge was tested at Ohmsett. Eighteen tests in all were conducted. Nine oil separation tests, eight decanting tests, and one liner test make up this total.

1.5 General Description of the Lancer Oil Recovery Barge

The model B05 barge tested is a 5 cubic meter (1,375 gallon) barge 21.0 feet long by 7.2 feet wide. The loaded draft of the barge is 3.5 feet. The barge is equipped with a decanting hose similar to that on the larger B100 barge that the Coast Guard uses with the Vessel of Opportunity Skimming System. The cover photo shows the larger B100 barge being lifted into the water. The B05 barge is similar as shown in Figure 1. The barge consists of a boat shaped inflation collar having 6 compartments and an oil containment bag hanging inside the inflation collar and sealed to it.

1.6 Lancer Barge Test Configuration

Figure 2 shows the test configuration used for all tests. For the oil separation tests, the barge was filled with oil from the Ohmsett tank farm and with basin water that was combined with the oil using a static mixer. During the oil separation tests, test samples were collected by technicians positioned on the lower level of the auxiliary bridge aft of the barge. After each test, fluid in the barge was offloaded to the auxiliary bridge recovery tanks using a Eureka CCN-150 pump suspended from a davit on the auxiliary bridge.

The setup for the decanting tests used dyed water from the auxiliary bridge recovery tanks to fill the barge by gravity flow. The oil and water filling system was not used. During the liner test, the barge was also filled from the auxiliary bridge tanks by gravity flow.

2

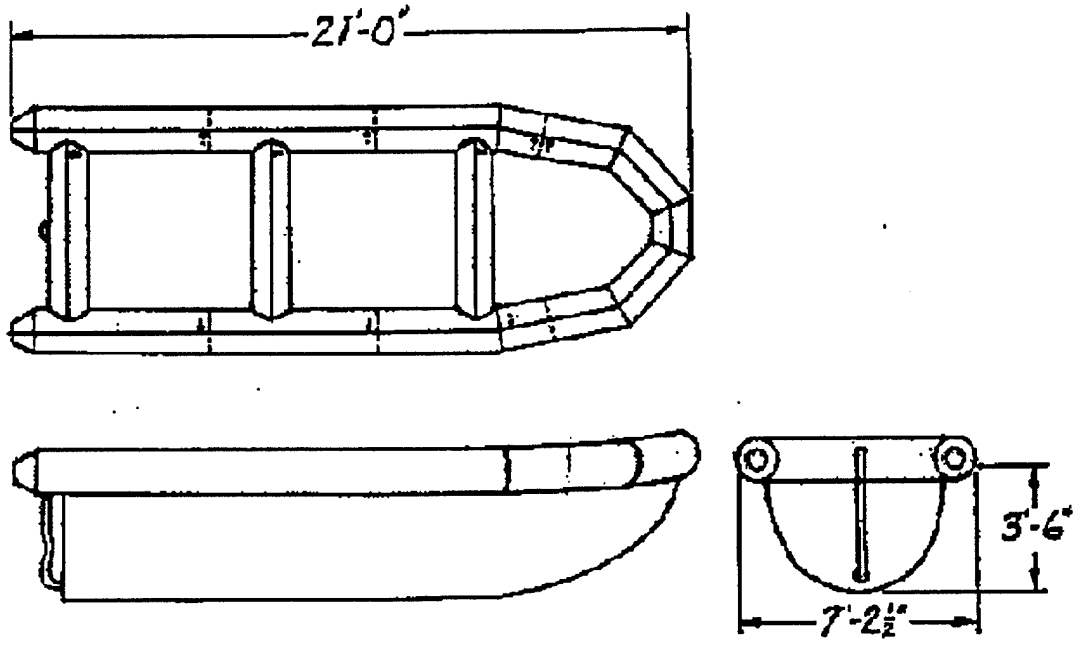

Figure 1 Diagram of Lancer Barge

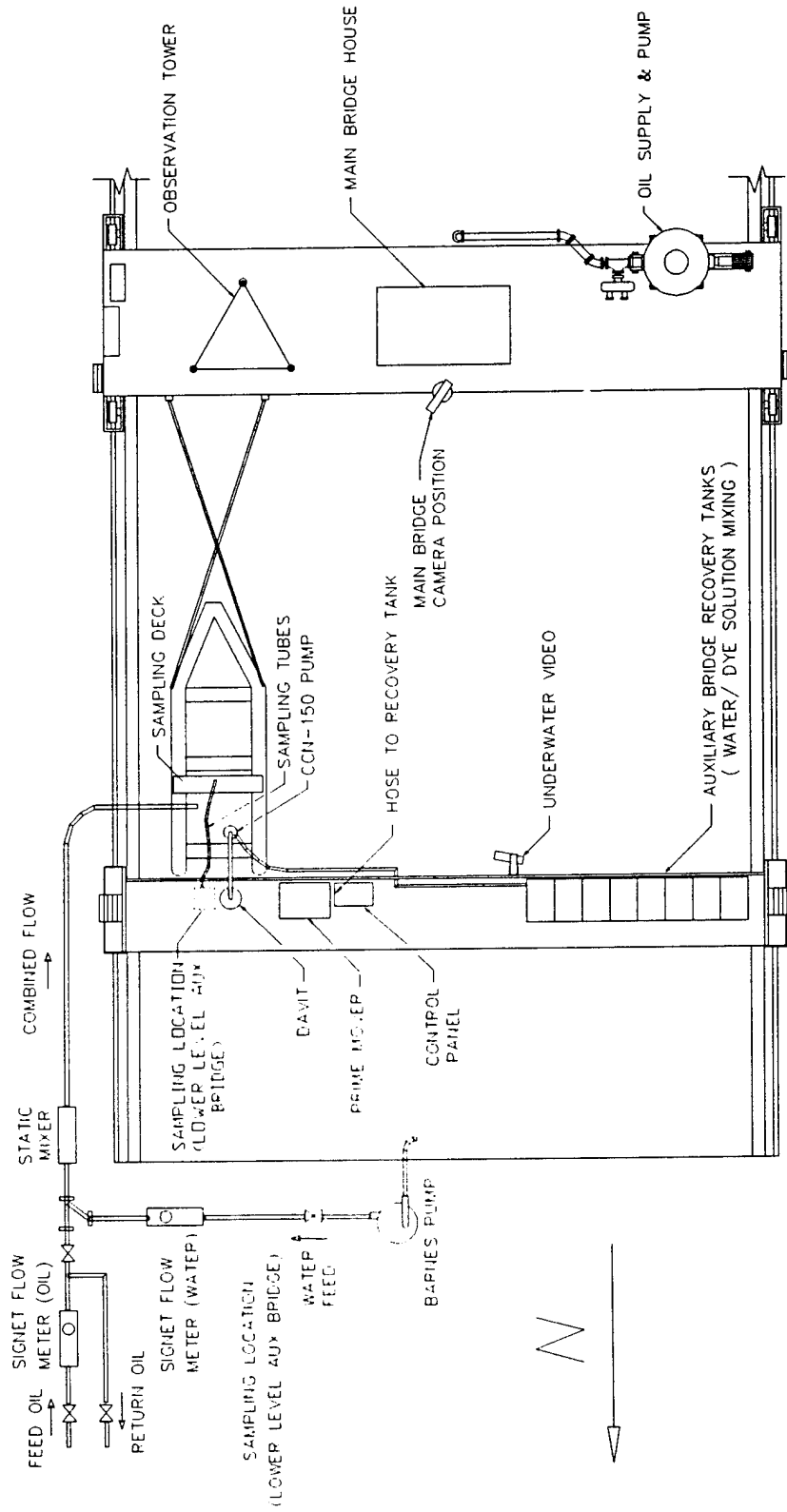

Figure 2 Lancer Barge Test Configuration

1.7 Liner for Lancer Barge

The liner provided for testing was a prototype. The plastic film used to construct the liner was a black plastic polyethylene film 0.013 inches thick. The liner was a rectangular box with square corners. The top surface had a large chimney-enclosed square hole in it for filling and emptying. In addition, there are five equally spaced straps attached on both of the long sides of the bag at the intersection of the long sides and the top. The straps and chimney surfaces are constructed of the same film as the liner. The purpose of the straps, or ties, is to position and secure the liner to the barge via the barge's "D" rings along the flotation collar.

2 ORGANIZATION

Minerals Management Service

- Provided Work Order tasking to MAR, Inc.
- Reviewed and approved Work Order Proposal
- Reviewed and approved Technical Project Report, Summary, and Video documentation.

MAR Inc.

- Prepared Work Order Proposal
- Conducted Testing
- Prepared Technical Project Report, Summary, and Video documentation.
- Prepared Monthly Status Reports

U.S. Coast Guard

- Provided funding
- Participated in preparation of Work Order.
- Provided guidance during test preparation and testing
- Participated in review of Work Order Proposal, Technical Project Report, Summary and Video documentation.

Axtrade Inc.

- U.S. distributor for the Lancer Barge
- Provided Lancer Barge for tests
- Provided support during testing
- Reviewed test plan

3 TEST OVERVIEW AND VARIABLES

3.1 Overview of Tests

3.1.1 Oil Separation Tests

The Lancer barge was tested while stationary and under tow to determine the effectiveness of oil separation within the barge over one hour's time. Nine tests were conducted to determine the effectiveness of oil separation, 4 tests in waves and 5 in calm water. All of the tests except one included a tow down the length of the basin. Two oil/water mixtures were tested, a 50/50 oil/water mix and a 10/90 oil/water mix. These represent the extremes of recovery efficiency determined in tests on the Coast Guard's Vessel of Opportunity Skimming System which is used to supply oil to the Lancer barge. The oil/water mixture was off-loaded at the conclusion of each separation test. During each off-loading, the effectiveness of a disk (approximately 0.6 meter (2 ft) diameter) mounted to the bottom of the suction pump was evaluated for its ability to keep the fabric of the oil bag away from the pump suction.

3.1.2 Decanting Tests

Eight decanting tests were conducted to determine the outflow from the decanting hose. Three barge loadings (1/3, 2/3, and full) and two speeds (1 and 2 kts) were used. Two of the tests were repeated. Dyed water was used for the decanting tests to make escaping water visible. No oil was used. All tests were in calm water.

3.1.3 Liner Tests

Two liner tests were planned but only one was conducted due to liner leaks. For the test conducted, the full barge was towed at 2 knots in calm water to determine the integrity of the liner.

3.2 Independent and Environmental Variables

3.2.1 Controlled Test Parameters (Independent Variables)

The parameters listed below were controlled intentionally during the tests to meet, as closely as possible, the target values called for in the test plan. Actual values varied from the target values. The actual values of the controlled parameters were measured and recorded, and these values, not the target values, were used in all calculations and in analyses of results. The controlled parameters were:

- o Tow Speed
- o Wavemaker Frequency and Stroke
- o Oil Type
- o Quantity of Oil and/or Water in Barge

Tow Speed - Bridge speeds used for the tests ranged from 1 to 2 knots. The speeds used for each test run are specified in Tables 2 through 4 in section 4. Bridge speed was sampled and recorded during each test run. The position of the bridge was also recorded during the run as a backup for tow speed. The bridge position information was not used.

Wavemaker Frequency and Stroke - Two wave conditions were used during the oil separation tests. Calm water conditions only were used during the decanting and liner tests. Surface elevation was measured during all wave tests by an acoustic altimeter mounted above the water surface on the main bridge. Wavemaker frequency was measured during each test run using a tachometer on the wave generator. Wave data was not analyzed for these tests and was not critical to test results as explained in sections 4 and 5.

Oil Type - A test oil was used only for the oil separation portion of these tests. This was a blended test oil that was on hand at Ohmsett from previous tests. There was no viscosity requirements on the oil used for these tests. The actual specific gravity and viscosity of the oil used is reported in section 5. The percentage of water in the oil used was determined before testing and the oil water ratio was adjusted to account for this water.

Quantity of Oil and/or Water in Barge - Flow meters were installed in the filling lines for the oil separation tests as shown in Figure 2. The quantity of oil flowing to the barge was also determined by tank farm ullage measurements for comparison to the flow meter readings. During the other tests, the amount of water added was determined by the tank levels in the calibrated recovery tanks on the auxiliary bridge.

3.2.2 Environmental Variables

Environmental variables which could have an effect on test results but which are not under the control of the test crew include the following:

- Wind Speed and Direction
- Air Temperature
- Water Temperature

These parameters were measured during each test run but they had little impact on the test results. The range of these values during the test period are given below.

Wind Speed and Direction - Average wind speeds varied from 0 to 10.7 m/sec (0 to 24 mph).

Air Temperature - Air temperature during testing varied from 10 °C to 30 °C (50 °F to 86 °F).

Water Temperature - The basin water temperature varied from 15.6 °C to 21.1 °C (60 °F to 70 °F).

3.3 Measured and Calculated Dependent Variables

The principal measured and calculated dependent variables were:

Oil Content of Fluid Samples (Oil Separation Tests) - The fluid at each of four levels above the bottom of the barge was sampled at 15 minute intervals after filling the barge. These samples were tested to determine the amount of oil present.

Fluid Lost During Decanting Tests - A totalizing flow meter was installed in the decanting hose from the barge to determine the fluid lost through the decanting hose during the decanting test runs.

3.4 Instrumentation

Table 1 lists the instrumentation used during the Lancer tests. Data from all instruments was collected at 0.1 sec intervals (a sampling rate of 10 Hz) by the Ohmsett data acquisition system.

Oil Separation Tests Two pumps were used to load the barge to full capacity at the start of each test. One pumped water and one oil. The pumps' discharges were combined through a static in-line mixer. The flow from the oil pump was regulated to obtain the correct oil/water ratio. The total oil and the total water added to the barge for each test was measured. The oil/water ratio in the barge was sampled after filling was completed by using an Ohmsett developed sampling system that allows measurement of the oil/water mixture at 4 levels above the bottom of the barge. Figure 3 shows a diagram of the sampling system. The capped sample tubes remained empty until it was time to take a sample. For each of the five sampling times, a fresh set of four tubes was used.

Table 1 Lancer Test Instrumentation

CHANNEL NO.	CHANNEL NAME	SENSOR	MODEL NO.
1	BRIDGE SPEED	Airpax Magnetic Pickup	70087-3040-012
2	BRIDGE DISTANCE	Computer Conversions Corp. Encoder Unit	HTMDS90-128-1PHA
3	WIND SPEED	R.M.Young Inc. Wind Sensor Unit	5130
4	WIND DIRECTION	R.M.Young Inc. Wind Sensor Unit	5130
5	AIR TEMP	R.M.Young Inc. Temp Sensor	41350
6	WATER TEMP	OMEGA RTD Probe	PR-11-2-100-1/4-6E
8	WAVE HEIGHT (SONIC)	Data Sonics	PSA-900-A
9	WAVE RPM	Airpax Magnetic Pickup	70087-3040-069
10	MARKER	Manual Push-Button	

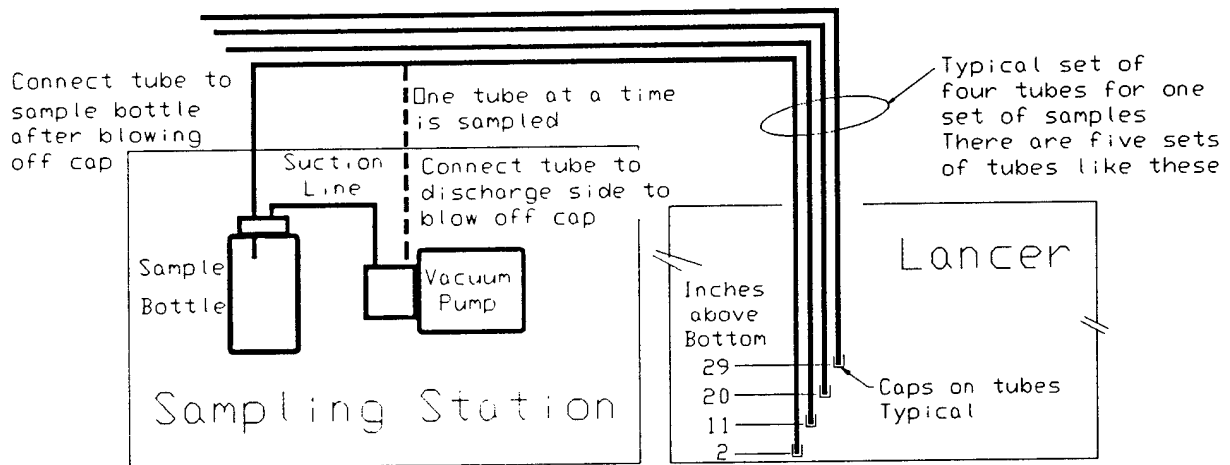

Figure 3 Fluid Sampling System Diagram

At the sampling time, four samples were taken in rapid succession. The procedure for taking a sample consists of connecting the sample tube to the discharge side of the vacuum pump to blow off the cap. A clean, labelled sample bottle is attached to the suction side of the pump. Once the cap is off, the sample tube is attached to the cap of the sample bottle and a sample is drawn into the sample bottle. The bottom of the sample tubes are at fixed distances from the bottom of the barge and the samples accurately reflect the fluid conditions at those levels. Samples were taken 5 times after filling during each of the 9 tests. The bridge speed was measured during towing. No other in-tank instrumentation was required for these tests.

Decanting Tests In the decanting tests, the barge was towed at the maximum safe speed and at half of the maximum safe speed. Each speed was tested with three different barge initial loadings, 100 %, 67 %, and 33 % of full load. As the barge was towed down the tank, the outflow through the decanting hose was measured using a flow meter. It was intended that the flow rate be averaged over the last half of the test run for each loading condition. However, the flow from the decanting hose was not continuous but came out in surges. The total flow meter reading is reported in section 5 but not averaged over time. Bridge speed was also measured. Underwater video of the oil bag shape was taken during these tests.

4 DESCRIPTION OF TESTS

4.1 Separation Tests

4.1.1 Separation Tests Performed

Some of the tests were conducted in waves and some in calm water with two different initial oil/water ratios as listed in Table 2. In all, nine tests were conducted.

Table 2 Oil Separation Tests

Test Number	Oil/Water Ratio	Sea Condition	Tow Takes Place After (Minutes)
1	50/50	Calm	Stationary
2	50/50	Calm	15
3	50/50	Calm	45
4	10/90	Calm	15
5	10/90	Calm	45
6	50/50	Simulated Sea State 2, SS2	30
7	10/90	Simulated Sea State 2, SS2	30
8	50/50	42 ft long regular waves, 2L	30
9	10/90	42 ft long regular waves, 2L	30

4.1.2 Separation Test Description

The test consisted of filling the barge with 1,300 to 1,400 gallons of an oil/water mixture and measuring the oil/water ratio of the fluid at four levels above the bottom of the barge over a one-hour time interval. Two pumps were used to fill the barge, one pumped water and one oil. The pump discharges were combined through a static in-line mixer. The flow from the oil pump was regulated to obtain the correct oil/water ratio. The total oil and the total water added to the barge for each test was measured.

Before testing began, the test oil was sampled and a viscosity-temperature curve determined by Ohmsett Test No. 16, "Viscosity-Brookfield." The specific gravity of the oil was also determined. Results of these tests are reported in section 5.

Two types of waves, in addition to calm water, were used for these tests. The first wave was a simulated sea state 2 condition the same as used in Ohmsett tests of the VOSS. A computer drives the wave maker through a cycle of frequencies with a fixed 3 inch stroke. This causes waves in the basin similar to the high frequency end of a typical sea state 2 wave spectrum. The second wave condition, called 2L waves, consisted of regular waves having a wave length

of approximately 42 feet, double the length of the Lancer barge. This should cause maximum agitation of the fluid mixture in the barge. A wave frequency of 18.75 cycles/minute corresponds to this wave length. A 6-inch wave stroke was used for maximum wave amplitude. Waves were generated during the entire period of each wave test, starting before filling began and continuing until the last sample had been collected.

Before filling the barge, all storage tanks used were sounded to determine the starting oil quantities. Then 1,300 to 1,400 gallons of oil/water mixture was pumped into the barge and new soundings were taken to determine the final oil amounts in the storage tanks. Totalizing flow meters were also installed in the oil and water fill lines to determine the amount of oil and water added and compared to the tank soundings. The volumetric ratio of oil to water was regulated during filling to provide the correct ratio for the test, either 50/50 or 10/90 oil to water. Filling the barge through a static mixer simulates the mix of oil and water that might be obtained from an oil skimmer operating on an oil spill.

Immediately after filling stopped, the first fluid samples of the mixture in the barge were taken. All samples were taken at the same four levels and same horizontal location relative to the barge. A location on the barge centerline about 0.6 times the length of the barge aft of the bow was used as shown in Figure 2. The lowest sample was taken 2.0 inches above the bottom of the barge's cargo bag. The other three samples were equally spaced 9 inches apart.

Measurements with the barge stationary were made at 0, 15, 30, 45, and 60 minutes nominal times after filling. The initial stationary samples were taken at the north end of the basin. One to two minutes were required to take all four samples. In all the tests except test 1, the barge was towed down the tank at the maximum safe tow speed of 2 knots at some time during the one hour test. This tow took place just after sampling was completed for one of the 15 minute intervals at the times shown in Table 2. The total time to complete sampling and tow ranged from 7 to 10 minutes. A sample was taken immediately after towing rather than waiting until the regular 15 minute interval. This procedure allows detection of any agitation in the fluid caused by the tow. Remaining stationary samples were taken at the south end of the basin at the regular 15 minute intervals. The barge was returned to the north end of the tank between runs.

Between tests, the oil/water mixture in the barge was off-loaded to storage using an Eureka CCN-150 off-loading pump. A 0.6 meter (2 ft) diameter plywood disk was mounted with its center on the bottom of the pump to limit the collapse of the barge bottom bag around the pump. Ideally, prior to beginning each test the barge should have no water or oil in it. As a practical matter, there was between 50 and 200 gallons of fluid left in the barge from previous tests each time the barge was reloaded. This fluid could not be pumped out due to the bag collapsing around the pump.

4.2 Decanting Tests

4.2.1 Decanting Tests Performed

Table 3 provides details of the eight decanting test runs made. All were made in calm water. Three different loads and two different tow speeds were used. Two of the tests were repeated.

4.2.2 Decanting Test Description

The purpose of the decanting tests was to determine if towing the barge while decanting fluid from the bottom of the oil bag enhances the outflow from the decanting hose. The two speeds tested were the maximum safe tow speed of 2 knots and one half of the maximum safe tow speed (1 knot). The three barge loadings were approximately 33, 67, and 100 percent of full load capacity (1,400 gallons). Dyed Ohmsett basin water was used to fill the barge for these tests. No oil was used.

Table 3 Decanting Tests

Test Number	Loading Level	Towing Velocity	Sea Condition
10	33% (466 gals)	1 knot	Calm
11	33% (466 gals)	2 knots	Calm
12	67% (932 gals)	1 knot	Calm
13	67% (932 gals)	2 knots	Calm
14	100% (1400 gals)	1 knot	Calm
15	100% (1400 gals)	2 knots	Calm
13a	Repeat of test 13		
15a	Repeat of test 15		

A flow meter in the discharge decanting hose was used to measure the outflow. Testing started with the lowest loading and proceed through the higher loadings up to full load. The barge was filled after each run with 466 gallons of water plus the amount lost during the previous run. The quantity of lost water was determined by the reading on the totalizing flow meter measuring the outflow. The total outflow and the average tow speed were determined.

4.3 Liner Tests

4.3.1 Liner Tests Performed

The following liner tests were planned.

Table 4 Liner Tests

Test Number	Barge Loading	Towing Velocity	Sea Condition
16	100% (1400 gals)	2 knots	Calm
17*	20% (280 gals)	1 knot	Calm

* Test was planned but not conducted due to liner leaks found during test 16.

4.3.2 Liner Test Description

This test was made to determine the integrity of the liner during towing. Two test runs were planned. The first liner test run was made with the liner installed with a powder dispersed between the barge and the liner. The barge was filled to 100% capacity with basin water and towed at 2 knots. After towing the barge was emptied and the liner removed. The liner and barge powder-covered surfaces were examined for evidence of water paths in the powder and any signs of damage to the liner.

The second test was to be a repeat of this procedure with 280 gallons (20% capacity) of water and a tow speed of 1 knot. The liner leaked badly during the first run and the second run was not conducted as a result.

During the liner installation, the test engineer noted the level of difficulty involved with the installation. Installation and disassembly was documented with video, as well.

5 RESULTS AND CONCLUSIONS

5.1 Oil Separation Test Results

5.1.1 Ideal Oil/Water Interface

Figure 4 shows the distribution of volume with height above the barge bottom for the fully loaded Lancer barge (1400 gallons). This curve was calculated based on the principal characteristics of the barge and the underwater shape observed. Because the cargo bag of the barge is not rigid, the distribution of volume with height depends on the total loading. In other conditions, the barge will collapse somewhat and the underwater shape will be different. Since the amount of water added to the barge is known for each separation test, the ideal separation line between the oil and water can be determined from Figure 4. The ideal separation condition assumes that there is complete separation of the oil and water, a condition that will never occur because some of the water is emulsified with the oil and will not separate by gravity.

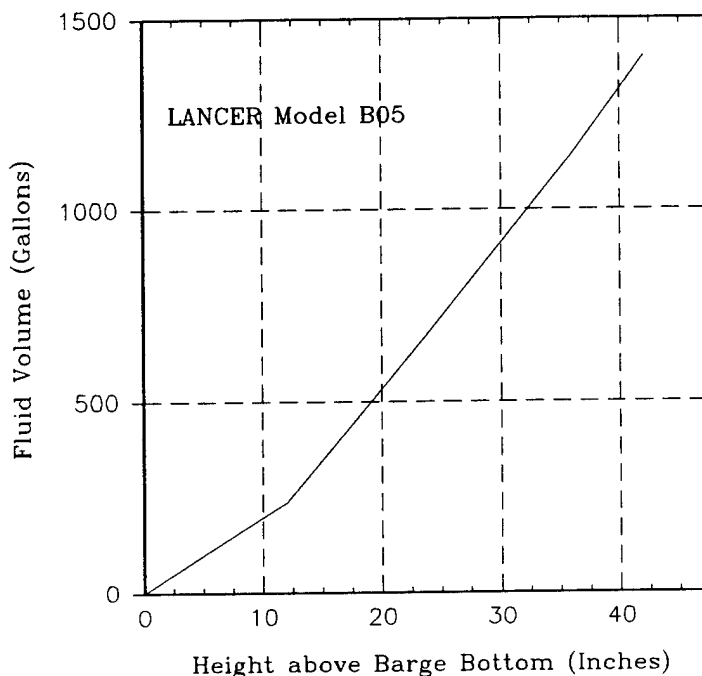

Figure 4 Fluid Capacity Distribution for Fully Loaded Barge

Table 5 gives a breakdown of the fluid mix for each of the tests. For 50/50 oil/water tests 1 to 3 and 8, the average fluid added to the barge was 1,335 gallons and Figure 4 applies. The average amount of water in the barge for these four tests was 677 gallons. The ideal oil/water interface would fall at 24 inches above the barge bottom with this amount of water. Test 6 was run with a total of 1,088 gallons of fluid so Figure 4 does not apply. Of the total for this test, 610 gallons was water. Allowing for some cargo bag collapse, the interface will still be approximately 24 inches above the bottom.

Four 10/90 oil/water tests are listed in Table 5, Tests 4, 5, 7, and 9. The average total quantity of fluid for these tests was 1,349 gallons so Figure 4 can be used. The average water quantity was 1,228 gallons. This puts the interface at approximately 38 inches above the bottom, well above the highest sample point of 29 inches.

5.1.2 Oil Characteristics

The test oil was an oil previously blended at Ohmsett for use in other tests. Characteristics of the oil were measured before testing began with the following results:

Specific Gravity	0.954
Viscosity @ 25°C	2800 cSt
Surface Tension	28.2 dynes/cm
Interfacial Tension	27.1 dynes/cm
Percent Water	7 %
Percent Solids	1 %

The amount of oil and water shown in Table 5 is the result of adjusting the measured quantities for the percent water and solids in the test oil.

Table 5 Oil Separation Test Fluid Quantities

Test No.	Oil (gals)	Water (gals)	Fluid Total (gals)	Percent Oil
1	673	674	1347	50.0
2	655	676	1331	49.2
3	678	666	1344	50.4
4	114	1249	1363	8.4
5	160	1218	1378	11.6
6	478	610	1088	43.9
7	95	1231	1326	7.2
8	627	692	1319	47.5
9	114	1215	1329	8.6

5.1.3 Calm Water Oil Separation Test Results

Figure 5 shows the average calm water results for the 50/50 oil/water ratio based on tests 1 to 3. Error bars showing one standard deviation in the data are presented along with the geometric average of the data. Data

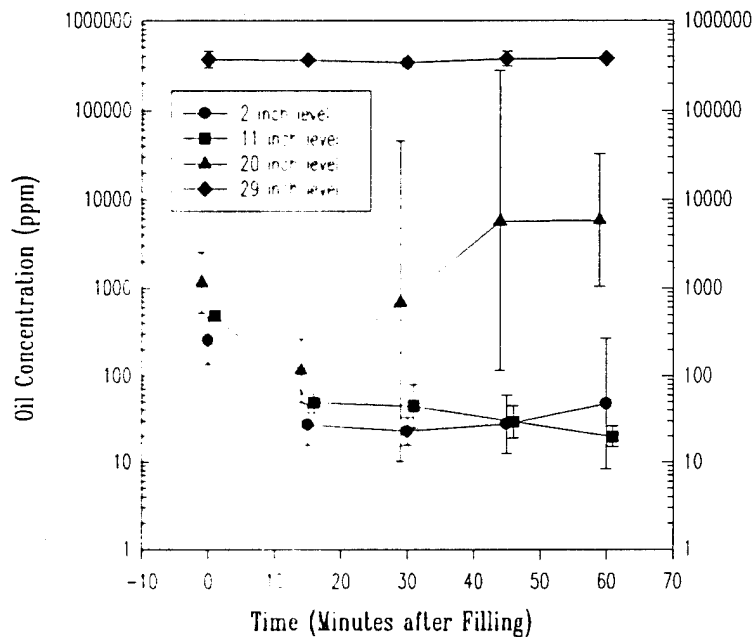

Figure 5 Oil Separation Test Results, 50/50 Oil/Water Mixture, Calm Water

points are shown shifted by ± 1 minute from the true 15 minute intervals so that the error bars don't overlap. Table 6 tabulates the data on which this plot is based. Figure 6 and Table 7 show the same data for the 10/90 oil/water mixture based on runs 4 and 5. As discussed in 5.1.1, the ideal interface line should fall at approximately 24 inches for a 50/50 oil/water mixture. The ideal curve would remain at 0 up to 24 inches and then rise immediately to 1,000,000. In reality, the oil and water do not completely separate even with infinite time. At the 20 inch level, just below the ideal separation line, there is a great deal of variability between test runs because this is a transitional region. At this level, samples varied from near zero to 9 percent oil. All the samples for the 10/90 oil/water mixture are below the transitional region (about 33 to 38 inches above the bottom). Therefore, the results have less scatter. No significant effect is apparent in these runs from towing the barge the length of the basin. The lowest sample does show a greater percentage of oil after the tow in some cases but the other samples show a decrease in the amount of oil present.

Table 6 Calm Water Oil Separation Test Results (50/50 Oil/Water Tests)

Time After Filling (minutes)	Test No.	Sampling Level (Inches above Barge Bottom)			
		2	11	20	29
		Oil Concentration (ppm)			
0	1	128	554	463	350,000
	2	304	444	1769	305,000
	3	427	468	1880	460,000
15	1	24	45	109	350,000
	2	49	39	51	340,000
	3	17	65	275	400,000
30	1	15	30	86,358	380,000
	*** 2 ***	27	34	55	300,000
	3	29	86	66	340,000
45	1	14	18	88,858	465,000
	2	23	35	67	320,000
	3	64	40	30,788	350,000
60	1	17	15	36,129	350,000
	2	18	20	1,188	380,000
	*** 3 ***	351	26	4,556	400,000

Test numbers with asterisks indicate data taken after towing the barge the length of the tank. No tow was made during test number 1.

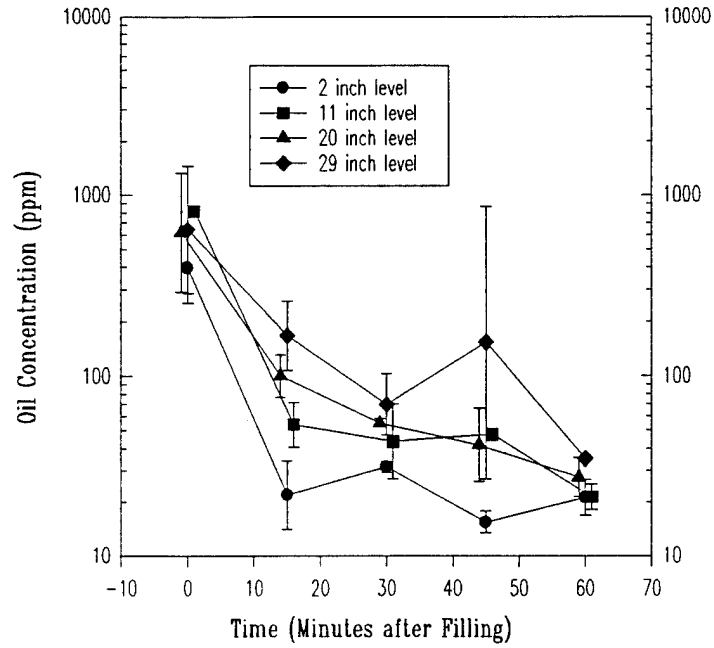

Figure 6 Separation Test Results, 10/90 Oil/Water

Table 7 Calm Water Oil Separation Test Results (10/90 Oil/Water Tests)

Time After Filling (minutes)	Test No.	Sampling Level (Inches above Barge Bottom)			
		2	11	20	29
		Oil Concentration (ppm)			
0	4	543	814	1,064	1,146
	5	287	No data	1039	363
15	4	16	44	121	227
	5	30	66	83	122
30	*** 4 ***	30	31	57	92
	5	33	61	53	53
45	4	17	48	30	521
	5	14	47	58	45
60	4	25	24	33	34
	*** 5 ***	18	19	23	36

Test numbers with asterisks indicate data taken after towing the barge the length of the tank.

5.1.4 Wave Characteristics

Runs 1 through 5 were made in calm water. Runs 6 and 7 were in a simulated sea state 2 (SS2) condition. Runs 8 and 9 were in a regular wave twice the length of the barge (2L). The SS2 wave is produced by varying the frequency with the wavemaker at a constant 3 inch stroke. The frequency is computer controlled in a saw tooth pattern over a frequency range from 12 to 43 cycles/minute. The 2L waves were produced with a 6 inch stroke and a constant frequency. The actual frequency for test 8 was 18.6 cycles/minute and for test 9, 18.8 cycles/minute. The target was 18.75 cycles/minute.

The wave characteristics are not critical to these tests. The 2L waves represent the maximum pitching conditions for the wave height tested and should be a worst case condition for agitating the oil/water mixture. The SS2 condition provides a mix of frequencies covering a range likely to be encountered in practice.

5.1.5 Wave Oil Separation Test Results

Figures 7 and 8 show the results for the two wave types and calm water and a 50/50 oil/water mixture after 15 minutes and 60 minutes settling time, respectively. Table 8 tabulates the values used in these figures. Figures 9 and 10 show the same data for the 10/90 mixture. Table 9 provides the values used. There is no indication in the test data for wave tests that towing has an important effect. Waves clearly do have an impact as shown in the figures. The 2L wave condition produces the most agitation as expected. Sea state 2 conditions appear to cause a slightly higher percentage of oil in the water near the bottom of the barge than does calm conditions, but the effect is very small and could be ignored for practical purposes. The 2L waves cause significant agitation and appear to lower the transitional region between the oil and water by 10 to 15 inches. Sampling was done near the pitch center of the barge which should be the point of least agitation. The transitional region may be affected even more at the ends of the barge where the decanting hose is located.

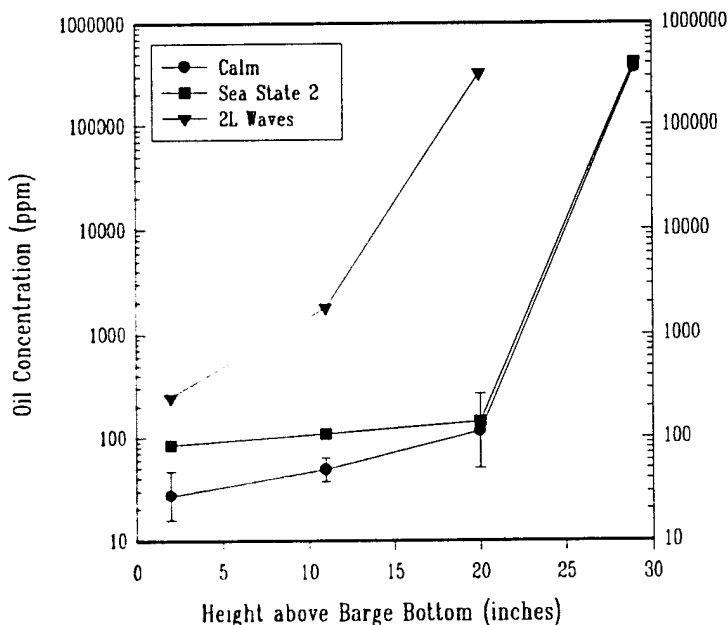

Figure 7 Oil Separation Test Results in Waves & Calm Water, 50/50 Oil/Water Mixture, after 15 Minutes

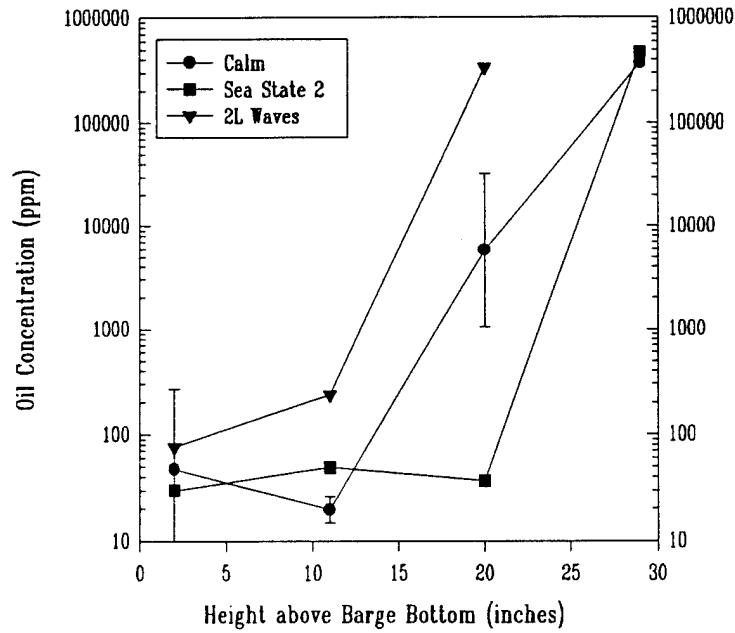

Figure 8 Oil Separation Test Results in Waves & Calm Water, 50/50 Oil/Water Mixture, after 60 Minutes

Table 8 Calm Water and Wave Oil Separation Test Results, 50/50 Oil/Water Tests

Time after Filling (minutes)	Sample Level abv Barge Bottom (Inches)	Test Number				
		1 Calm	2 Calm	3 Calm	6 SS2*	8 2L*
Oil Concentration (ppm)						
15	2	24	49	17	84	246
	11	45	39	65	109	1,790
	20	109	51	275	143	320,000
	29	350,000	340,000	400,000	400,000	No data
60	2	17	18	351	30	76
	11	15	20	26	49	236
	20	36,128	1,188	4,556	37	340,000
	29	350,000	380,000	400,000	470,000	No data

* SS2 - Sea State 2 waves

2L - Wave twice the length of the Lancer Barge

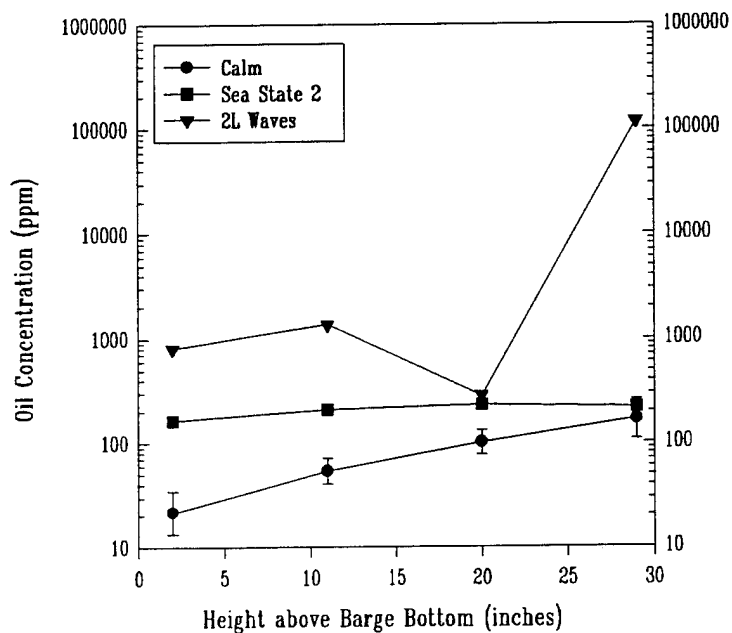

Figure 9 Oil Separation Test Results in Waves & Calm Water, 10/90 Oil/Water Mixture, after 15 Minutes

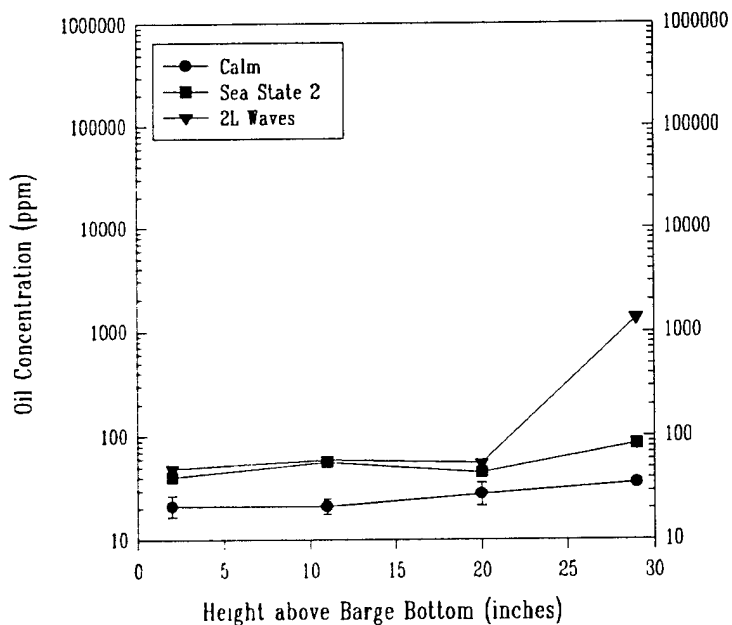

Figure 10 Oil Separation Test Results in Waves & Calm Water, 10/90 Oil/Water Mixture, after 60 Minutes

Table 9 Calm Water and Wave Oil Separation Test Results (10/90 Oil/Water Tests)

Time after Filling (minutes)	Sample Level abv Barge Bottom (Inches)	Test Number			
		4 Calm	5 Calm	7 SS2*	9 2L*
15	2	16	30	164	808
	11	44	66	209	1,361
	20	121	83	230	283
	29	227	122	217	116,245
60	2	25	18	41	49
	11	24	18	57	606
	20	33	23	45	55
	29	34	36	84	1,339

* SS2 - Sea State 2 waves

2L - Wave twice the length of the Lancer Barge

5.1.6 Off-loading Results

During the off-loading, the test engineer observed the efficiency of oil reaching the pump and the collapse of the oil bag around the pump suction. It was found to be beneficial to raise the pump as the bag collapsed to keep the pump in the bulk of the fluid and above the collapsing bag. With this procedure, all but about 100 gallons of oil could be pumped from the barge without blockage of the pump suction.

5.2 Decanting Test Results

Table 10 shows the results of the decanting tests. The total outflow readings are reported instead of the average rate over the last half of the run. The flow exited the decanting tube in surges rather than as a steady flow. At the smallest loading the outflow rate increased from nothing to 190 gallons as the tow speed was increased from 1 to 2 knots. With the barge 2/3 full (runs 12 and 13) there is also an outflow increase from 40 to 260 gallons as the speed increased. However, when run 13 was repeated as run 13a, the outflow was too low to measure indicating a drop in flow from 40 to nothing. The full barge internal waterline was approximately the same as the external waterline. When the barge was full there was no significant increase in the outflow rate between 1 and 2 knots. There is no clear indication of how outflow rates vary with barge loading. At all loadings the outflow at 1 knot was between 0 and 15 gallons/minute (gpm). At 2 knots the range was from 0 to 130 gpm. There is an indication that outflow increases with speed but the results are mixed.

Table 10 Outflow Test Results

Test No.	Tow Speed (knots)	Load (gallons)	Estimated Loss (gallons)	Run Time (Minutes)
10	1	466	Nil	4
11	2	466	190	2
12	1	891	40	4
13	2	932	260	2
14	1	1160-1400	60	4
15	2	1160-1400	60	2
13a	2	700-940	Nil	2
15a	2	1160-1400	60-100	2

5.3 Liner Test Results

Instructions for installing the liner were received by fax from Axtrade, Inc., and reviewed. The liner was then opened to plan the actual installation. There was no indication of a bow or a stern end on the liner nor did the instructions specify the direction the liner was to be installed. However, the liner does have a long and a short section. The liner finally was installed with the long section towards the stern.

While unpacking the liner, a hole was discovered in the bottom of the liner. This hole was patched. Other small pin hole leaks were subsequently discovered and patched. These holes occurred in the crease where the bag was folded and were all on one layer.

After installing the liner, test 16 was run. The surfaces between the liner and the barge cargo bag were powdered. The test was conducted at 2 knots with a full load, 1454 gallons, of water from the basin. After the test, the liner was removed and water was found between the liner and barge. An estimated 14 gallons of water leaked through or around the liner. Because the liner failed to prevent water from "contaminating" the barge cargo bag, further testing was not conducted.

APPENDIX A FLUIDS TESTING

The measurements made in the chemistry laboratory at the Ohmsett Facility are as follows:

1. VISCOSITY (ASTM D2983)

Viscosity is measured using a Brookfield Engineering Model LV Viscometer. The samples are collected in 600 ml beakers, the contents are cooled to 10° C, then the temperature is raised to 60° C using a Brookfield Constant Temperature Bath. Viscosity measurements are made every 10° C, yielding a temperature vs. viscosity curve for each sample collected. This is done to find the viscosity at variable test temperatures as is found in the test tank.

2. SURFACE & INTERFACIAL TENSION (ASTM D971)

Surface and interfacial tensions are measured with a Fisher Scientific Tensiomat. Approximately 50 mls of oil is needed to determine both surface and interfacial tensions. Measurements are made under standardized nonequilibrium conditions in which the measurement is completed one minute after formation of the interface.

3. SPECIFIC GRAVITY (ASTM D1298)

This analysis is performed using the hydrometer method. The oil sample is transferred to a 500 ml cylinder, the appropriate hydrometer is lowered into the sample and allowed to settle. The hydrometer scale is read and the temperature is recorded.

4. WATER AND SEDIMENT IN PETROLEUM (ASTM D1796)

A recovered oil sample of approximately 100 mls is mixed with an appropriate solvent (toluene), heated to 60° C, and rotated at 2000 rpms in a centrifuge for 15 minutes. The amount of water and sediment is measured and the percentages calculated from the amount of sample used.

5. OIL AND GREASE IN WATER, TOTAL RECOVERABLE (INFRARED)

A 500 - 1000 ml water/oil sample is acidified to a pH less than 2.0 and the oil is extracted with carbon tetrachloride. The oil and grease concentration is determined by comparison of the infrared absorbance of the sample extract with standards, using a Shimadzu IR 435 spectrophotometer.

6. OIL AND GREASE IN WATER, PETROLEUM ETHER EXTRACTION (GRAVIMETRIC) (D4281 Modified using ozone-friendly solvent)

A 500 - 1000 ml water/oil sample is taken and the oil is extracted using petroleum ether. The ether is evaporated and the remaining oil concentration is determined gravimetrically.

7. DEMULSIBILITY CHARACTERISTICS OF LUBRICATING OILS (ASTM D2711)

A 405 ml sample of oil and 45 mls of deionized water are stirred together for 5 minutes in a separatory funnel. After a settling period, percentage of water in the oil and the volumes of water and emulsion separating from the oil are measured and recorded.

LANCER INFLATABLE BARGE (WO 11)

DEMULSIBILITY ANALYSIS						
Separatory Funnel	#1	#2	#3	AVG	HIGH	LOW
Water in Oil, %	2.5	15.0	18.0	11.8	18.0	2.5
Free Water, mL:						
From funnel	12.5	10.0	11.0	11.1	12.5	10.0
After centrifuging	0.3	0.8	1.7	0.9	1.7	0.3
Total Free Water, mL	12.8	10.8	12.7	12.0	12.8	10.8
Emulsion, mL	80.0	40.0	90.0	70.0	90.0	40.0

BOTTOM SOLIDS & WATER ANALYSES			
TEST # / SAMPLE	% WATER	% SOLIDS	TOTAL %
T1D0	35.0	0.5	35.5
T1D1	35.0	0.6	35.6
T1D2	38.0	0.4	38.4
T1D3	46.0	0.5	46.5
T1D4	35.0	0.4	35.4
T2D0	30.5	0.4	30.9
T2D1	34.0	0.4	34.4
T2D3	32.0	0.4	32.4
T2D4	38.0	0.4	38.4
T3D0	46.0	0.6	46.6
T3D1	40.0	0.5	40.5
T3D2	34.0	0.4	34.4
T3D3	35.0	0.4	35.4
T3D4	40.0	0.4	40.4
T6D1	40.0	0.3	40.3
T6D3	16.0	0.5	16.5
T6D4	47.0	0.6	47.6
T8D0	34.0	0.4	34.4
T8C1	32.0	0.4	32.4
T8C2	32.0	0.6	32.6
T8C3	37.0	0.6	37.6
T8C4	34.0	0.4	34.4

LANCER INFLATABLE BARGE
Totals - Oil in Water / Water in Oil Analyses

TEST # /SAMPLE	TIME (min)	DEPTH OFF BOTTOM (inches)	VOLUME (mls)	OIL CONC (mg/l)	PERCENT OIL (%)
T1A0	0	2	800	128.30	0.013
A1	15	2	650	23.70	0.002
A2	30	2	710	14.70	0.001
A3	45	2	660	14.30	0.001
A4	60	2	400	16.60	0.002
B0	0	11	720	554.00	0.055
B1	15	11	610	44.60	0.004
B2	30	11	840	30.10	0.003
B3	45	11	580	18.00	0.002
B4	60	11	750	14.60	0.001
C0	0	20	740	463.00	0.046
C1	15	20	650	108.60	0.011
C2	30	20	850	86,357.60	8.636
C3	45	20	570	88,857.90	8.886
C4	60	20	840	36,128.50	3.613
D0	0	29	n/a	n/a	35
D1	15	29	n/a	n/a	35
D2	30	29	n/a	n/a	38
D3	45	29	n/a	n/a	46.5
D4	60	29	n/a	n/a	35
T2A0	0	2	580	304.10	0.03
A1	15	2	720	49.10	0.005
A2	30	2	700	27.00	0.003
A3	45	2	740	23.40	0.002
A4	60	2	690	18.30	0.002
B0	0	11	730	443.70	0.044
B1	15	11	880	39.20	0.004
B2	30	11	850	33.50	0.003
B3	45	11	810	35.20	0.004
B4	60	11	670	20.10	0.002
C0	0	20	830	1,768.60	0.177
C1	15	20	870	51.20	0.005
C2	30	20	870	54.50	0.005
C3	45	20	610	67.20	0.007
C4	60	20	640	1,188.30	0.119
D0	0	29	n/a	n/a	30.5
D1	15	29	n/a	n/a	34
D2	30	29	n/a	n/a	30
D3	45	29	n/a	n/a	32
D4	60	29	n/a	n/a	38

TEST # /SAMPLE	TIME (min)	DEPTH OFF BOTTOM (inches)	VOLUME (mls)	OIL CONC (mg/l)	PERCENT OIL (%)
T3A0	0	2	700	427.40	0.043
A1	15	2	740	17.00	0.002
A2	30	2	700	29.30	0.003
A3	45	2	650	63.90	0.006
A4	60	2	510	351.10	0.035
B0	0	11	730	468.00	0.47
B1	15	11	810	65.10	0.007
B2	30	11	640	86.30	0.009
B3	45	11	830	40.40	0.004
B4	60	11	690	25.60	0.003
C0	0	20	650	1,880.00	0.188
C1	15	20	860	275.30	0.028
C2	30	20	640	65.80	0.007
C3	45	20	860	30,087.80	3.079
C4	60	20	720	4,555.50	0.456
D0	0	29	n/a	n/a	46
D1	15	29	n/a	n/a	40
D2	30	29	n/a	n/a	34
D3	45	29	n/a	n/a	35
D4	60	29	n/a	n/a	40
T4A0	0	2	730	542.90	0.054
A1	15	2	690	15.50	0.002
A2	30	2	770	29.60	0.003
A3	45	2	800	17.00	0.002
A4	60	2	800	25.00	0.003
B0	0	11	820	814.40	0.081
B1	15	11	780	44.00	0.004
B2	30	11	850	31.00	0.003
B3	45	11	730	47.80	0.005
B4	60	11	880	23.90	0.002
C0	0	20	840	1,064.20	0.106
C1	15	20	840	120.70	0.012
C2	30	20	800	57.00	0.006
C3	45	20	810	30.00	0.003
C4	60	20	780	33.00	0.003
D0	0	29	820	1,145.50	0.115
D1	15	29	820	227.30	0.023
D2	30	29	700	91.80	0.009
D3	45	29	770	520.80	0.052
D4	60	29	860	34.20	0.003

TEST # /SAMPLE	TIME (min)	DEPTH OFF BOTTOM (inches)	VOLUME (mls)	OIL CONC (mg/l)	PERCENT OIL (%)
T5A0	0	2	700	286.60	0.029
A1	15	2	770	30.10	0.003
A2	30	2	750	32.70	0.003
A3	45	2	830	14.20	0.001
A4	60	2	890	17.70	0.002
B0 (No Sample)	0	11			
B1	15	11	760	66.10	0.007
B2	30	11	720	60.50	0.006
B3	45	11	740	46.50	0.005
B4	60	11	790	18.50	0.002
C0	0	20	880	102.60	0.01
C1	15	20	860	82.90	0.008
C2	30	20	840	53.30	0.005
C3	45	20	750	57.70	0.006
C4	60	20	860	23.20	0.002
D0	0	29	840	362.70	0.036
D1	15	29	860	122.10	0.012
D2	30	29	830	53.40	0.005
D3	45	29	810	45.00	0.005
D4	60	29	760	36.20	0.004
T6A0	0	2	750	645.30	0.065
A1	15	2	730	84.40	0.008
A2	30	2	710	55.70	0.006
A3	45	2	690	50.80	0.005
A4	60	2	770	30.00	0.003
B0	0	11	760	1,066.40	0.107
B1	15	11	650	109.00	0.011
B2	30	11	770	54.20	0.005
B3	45	11	810	48.00	0.005
B4	60	11	870	48.90	0.005
C0	0	20	850	1,611.80	0.161
C1	15	20	700	142.70	0.014
C2	30	20	640	734.50	0.073
C3	45	20	740	1,939.80	0.194
C4	60	20	850	36.70	0.004
D0 (No Sample)	0	29			
D1	15	29	n/a	n/a	40
D2 (No Sample)	30	29			
D3	45	29	n/a	n/a	16
D4	60	29	n/a	n/a	47

TEST # /SAMPLE	TIME (min)	DEPTH OFF BOTTOM (inches)	VOLUME (ml)	OIL CONC (mg/l)	PERCENT OIL (%)
T7A0	0	2	740	3,474.30	0.347
A1	15	2	730	164.30	0.016
A2	30	2	690	104.60	0.01
A3	45	2	750	83.40	0.008
A4	60	2	730	40.60	0.004
B0	0	11	860	2,938.90	0.294
B1	15	11	840	209.10	0.021
B2	30	11	860	120.90	0.012
B3	45	11	800	68.40	0.007
B4	60	11	850	56.60	0.006
C0	0	20	740	3,570.30	0.357
C1	15	20	770	230.10	0.023
C2	30	20	730	284.50	0.028
C3	45	20	890	115.60	0.012
C4	60	20	870	45.00	0.005
D0	0	29	770	4,597.40	0.46
D1	15	29	730	216.90	0.022
D2	30	29	680	261.80	0.026
D3	45	29	810	109.20	0.011
D4	60	29	800	84.40	0.008
T8A0	0	2	710	1,000.70	0.1
A1	15	2	720	246.00	0.025
A2	30	2	700	164.00	0.016
A3	45	2	740	174.80	0.017
A4	60	2	710	76.20	0.008
B0	0	11	660	1,237.80	0.124
B1	15	11	740	1,790.50	0.179
B2	30	11	830	909.60	0.091
B3	45	11	850	2,994.10	0.299
B4	60	11	830	236.30	0.024
C0	0	20	840	79,559.50	7.956
C1	15	20	n/a	n/a	32
C2	30	20	n/a	n/a	32
C3	45	20	n/a	n/a	37
C4	60	20	n/a	n/a	34
D0	0	29	n/a	n/a	34
D1 (No Sample)	15	29			
D2 (No Sample)	30	29			
D3 (No Sample)	45	29			
D4 (No Sample)	60	29			

TEST # /SAMPLE	TIME (min)	DEPTH OFF BOTTOM (inches)	VOLUME (mls)	OIL CONC (mg/l)	PERCENT OIL (%)
T9A0	0	2	890	2,661.80	0.266
A1	15	2	770	807.80	0.081
A2	30	2	740	194.90	0.019
A3	45	2	770	118.60	0.012
A4	60	2	740	48.80	0.005
B0	0	11	930	1,833.30	0.183
B1	15	11	790	1,360.70	0.136
B2	30	11	710	226.70	0.023
B3	45	11	880	119.40	0.012
B4	60	11	870	59.50	0.006
C0	0	20	770	3,623.40	0.362
C1	15	20	860	283.00	0.028
C2	30	20	850	208.90	0.021
C3	45	20	840	135.70	0.014
C4	60	20	730	54.90	0.005
D0	0	29	n/a	n/a	0.84
D1	15	29	530	116,245.30	11.625
D2 (No Sample)	30	29			
D3	45	29	790	727.80	0.073
D4	60	29	790	1,339.20	0.134

APPENDIX B INSTRUMENTATION

This Appendix includes the non-standard Ohmsett Instrumentation used for the Lancer Test Series. (Also some pertinent regular instrumentation records are included.)

These instruments were:

1. 150 gpm FS Signet Flowmeter (3" saddle, water) S/N 207153
2. 75 gpm FS Signet Flowmeter (2" saddle, oil)
3. OMEGA Outflow Meter, DPF 401, w/pulse input Bd.. (4")
4. Milltronics Portable Tank Level Meter, S/N 005870

Also included is some calibration information on the Bridge speed and distance annual calibration, the wave cpm calibration data, and a listing is provided showing the gain and offset valves used for each of the computer data channels.

See index on the next page.

Instrumentation Appendix Index

- Description
- Index
- Wave CPM Calibration Check Procedure
- CPMCAL01 - CPMCAL06 Computer Run Sheets
- Calibration for Lancer Test of the Probe by Milltronics
- Channel set up sheet for the computer
- WTRFLO07.DAT Run Sheet for 3" Waterflo Calibration
- Graph of Meter Flow (gpm) vs. Vol/Time Flow (gpm)
- CPMCAL01-CPMCAL06 CPM Calibration Run Sheets
- Bridge Drive Speed and Distance Calibration Table (yearly) 5/9/94
- Bridge Drive Speed and Distance Calibration Runs (SPDDS01-SPDDS08)

WAVE CPM CALIBRATION CHECK PROCEDURE:

1. Start up wave generator, adjust the CPM speed to read the proper CPM reading on the Bridge Operator's console readout.
2. Record data for 3 minutes (after the CPM has stabilized).
3. During the 3 minute data run, with a stop-watch, the Bridge Operator manually counts the CPM rate while viewing the B&W Monitor looking at the wave flaps. The Bridge Operator then records these values and compares his count with the computer collected mean values.

See the CPMCAL01-CPMCAL06 data sheets. (On these data sheets the Bridge Operator's readings would correspond to the desired CPM rate values.)

3/24/94

Calibration for Lancer Test of the Probe by Milltronics

Part No. 86012000

Milltronics "The Probe"

S/N 005870

Including: Model DPI 2448 Conlog Meter

Input 4-20 MA, Output 0-199 (Requires 24V P.S. (D.C.) (For Loop & Meter)

Part # 98-8170-150-001 S/N A22930143

Mounted the Probe on a Tripod and aimed at a flat wall while using a tape measure to check the distances.

<u>Probe (Meters) Meter Readings</u>	<u>Probe Meter Readings (Feet)</u>	<u>Probe Meter (Inches)</u>	<u>Tape Measure Readings (Inches)</u>
4.06 Meters	13.32 Feet	159.84"	161.5"
3.43 "	11.25 Feet	139.039"	135.250"
2.63 "	8.629 Feet	103.543	103.875
1.46 "	4.79 Feet	57.48 X	57.625" Y

$$r = 0.9999$$

$$a = -0.756351143$$

$$b = 1.011786315$$

$$y = bx + a$$

Calibration of 4 MA to 20 MA output.

4 MA = .25 Meter 20 MA = 4.5 Meter

<u>Meters</u>	<u>Readout Before Gain Adjustment</u>	<u>Readout After Gain Adjustment</u>	Note: Adj. the gain of External Loop Meter (on top of power supply) to read proper readings as shown to the left.
2.75 Meters	431"	108.0"	
3.74 Meters	587"	147.0"	
4.40 Meters	692"	173.0"	
1.2 Meters	187"	47.0"	

Spare Port Tank Level Meter

<u>Probe Meter readings (Meters)</u>	<u>Probe Meter Readings (Feet)</u>	<u>Probe Meter Readings (Inches)</u>	<u>Tape Measure Readings (Inches)</u>
4.06	13.32	159.84	161.5
3.43	11.25	139.04	135.25
2.63	8.629	103.54	103.88
1.46	4.79	57.48	57.63

BRIDGE DRIVE SPEED AND DISTANCE CALIBRATION TABLE - 5/9/94

	RUN #	SPEED	METER SPEED	POT SETTING	DISTANCE "A" TIME	DISTANCE "B" TIME	ZERO DIFF FT.- IN.
SPDDS01.DAT	1S	0.25	.23 - .27	—	3.8 (.2597 KT)	3.72 (.2645 KT)	
SPDDS02.DAT	1N	0.25	.23 - .31	—	3.57 (.2764 KT)	3.83 (.2576 KT)	+ 3 3/8
SPDDS03.DAT	2S	0.5	.49 - .51	.61 - .62	1.96 (.5034 KT)	1.96 (.5034 KT)	
SPDDS04.DAT	2N	0.5	.49 - .51	.68 - .71	1.95 (.506 KT)	1.95 (.506 KT)	+ 3
SPDDS05.DAT	3S	1.0	.99 - 1.01	2.54	.98 (1.007 KT)	.99 (.9967 KT)	
	3N	1.0	.99 - 1.01	2.38	.98 (1.007 KT)	.97 (1.084 KT)	+ 1 1/2
SPDDS06.DAT	4S	1.5	1.49 - 1.52	4.31	.65 (1.518 KT)	.65 (1.518 KT)	
	4N	1.5	1.48 - 1.51	4.16	.66 (1.495 KT)	.65 (1.518 KT)	+ 1/2
SPDDS07.DAT	5S	2.0	2.01 - 2.04	6.40	.48 (2.056 KT)	.48 (2.056 KT)	
	5N	2.0	1.98 - 2.02	6.0	.49 (2.014 KT)	.49 (2.014 KT)	+ 1 3/4
	6S	4.0					
	6N	4.0					
	7S	6.0					
	7N	6.0					
SPDDS08.DAT	8S	2.0	1.99 - 2.04	6.31	.48 (2.056 KT)	.49 (2.014 KT)	
	8N	2.0	1.98 - 2.02	6.15	.48 (2.056 KT)	.49 (2.014 KT)	0

4. Instrument Technician - RECORD the bridge speed and distance onto computer files for each of the sixteen runs.

CALCULATE AND REPORT

Calculate the stopwatch measured speeds for the seven different speeds run and calculate the variance in feet per minute between the speed meter reading and the stop watch measurement. Calculate the variance between the duplicate speed runs (#5 and #8). Also calculate the average zero start point variance.

Report the meter/stopwatch variance, duplicate run variance, and the average zero variance. Include in the report a graph of meter reading vs. stopwatch speeds with a least squares linear regression curve fit (use Lotus 1-2-3 data regression option). Also include a plot of the computer record of each test -- speed vs. time.

APPENDIX C QUALITY ASSURANCE

All quality assurance at Ohmsett comes under the Ohmsett Quality Assurance Plan. The Quality Assurance Plan is on file with the Master Ohmsett Instrumentation Schedule at the Ohmsett general office. The individual instrumentation data is also on file at Ohmsett. All calibration information, including procedures, can be located in the individual instrument's file.

Daily Instrumentation Calibration Procedures

At the start and conclusion of each test day, the following procedures were used:

All of the instrumentation was recorded and checked. The data computer was set up for a 60 second data run to collect sensor information on all of the active data channels. The calibration data runs were done at the beginning of each test day and at the end of each test day. This data was reviewed by the Instrumentation Engineer and by the Test Engineer and/or Test Designer and Test Conductor. The data is on file at the Ohmsett Facility.

The video stations (underwater and above water) were turned on during the initial console checkouts at the beginning of each test day. When turned on, the video camera pictures were checked. The pan, tilt, zoom, iris control adjustments of the cameras were checked. The tape counters were zeroed and the video tapes for the days tests were positioned to the correct tape counter readings.

The Quality Assurance Plan specifies that the Project Quality Control Officer complete the Quality Checklist. The checklist also includes any special spot checks or calibration checks during the testing. A copy of this document is included in this Appendix.

APPENDIX D THE OHMSETT FACILITY

The Minerals Management Service of the U.S. Dept. of the Interior operates the National Oil Spill Response Test Facility, known as Ohmsett (Oil and Hazardous Materials Simulated Environmental Test Tank), located on the U.S. Naval Weapons Handling Station, Earle, in Leonardo, New Jersey. Ohmsett is used for the testing and development of devices and techniques for the control and cleanup of oil spills. Figure D-1 is an overall plan of the facility.

The primary feature of the facility is a pile-supported concrete basin with a water surface 203 m (666 ft) long, 20 m (66 ft) wide, and with a water depth of 2.4 m (8 ft). The basin is filled with brackish water from Sandy Hook Bay and the water has a salinity of approximately 17 parts per thousand.

The basin is spanned by three movable carriages. The towing carriage, referred to as the "main bridge", is capable of exerting a force of 151,000 N (34,000 lbf) while towing floating equipment at speeds up to 3.3 m/sec (6.5 knots or 11 ft/sec) for at least 40 seconds; tests of longer duration can be conducted at lower speeds. The main bridge has a built-in oil barrier boom which can be lowered to skim oil to the north end of the basin for cleanup.

The main bridge is equipped with a 5.7 m³ (1500 gallon) oil storage tank and a progressive-cavity positive displacement pump which can deliver 1000 cPs oil at 70 m³/hr (310 gallons per minute) and 20,000 cPs oil at 26 m³/hr (115 gpm).

A second carriage, the auxiliary bridge, moves with the main bridge and provides storage for recovered fluids. A removable video bridge (not shown in Figure D-1) spans the space between the main and auxiliary bridges and provides support for underwater and above-water video cameras.

The third carriage is the vacuum bridge, which is generally stored at the south end of the basin and is used for cleaning the basin bottom; it is not shown in Figure D-1.

The principal systems of the basin include a flap-type wave generator at the south end and a wave-absorbing beach at the north end which can be lowered to allow waves to reflect from the north wall. The wave generator can produce regular (unidirectional sinusoidal) waves up to 61 cm (2 ft) high and up to 45 m (150 ft) long. With the beach lowered, a confused condition resembling a harbor chop can be produced, with heights to 70 cm (2.3 ft).

The basin water is filtered by recirculation through a 270 m³/hr (9500 ft³/hr) diatomaceous earth filter system, which produces sufficient water clarity to allow extensive use of underwater video photography to record testing.

Testing at the facility is served from the multi-level control tower building, which houses the bridge and wavemaker controls, the data acquisition system and computer systems, and offices. A 650 m² (7000 ft²) building adjacent to the basin houses offices, a machine shop, and an equipment preparation area. A separate self-contained chemistry laboratory provides test facilities for analyzing samples of water, oil, and mixtures.

MAR, Inc., the operating contractor, provides a permanent on-site staff of eight, and augments this staff with additional engineering, scientific, and quality assurance personnel as needed. Chapman, Inc., a subcontractor, provides a permanent staff of four.

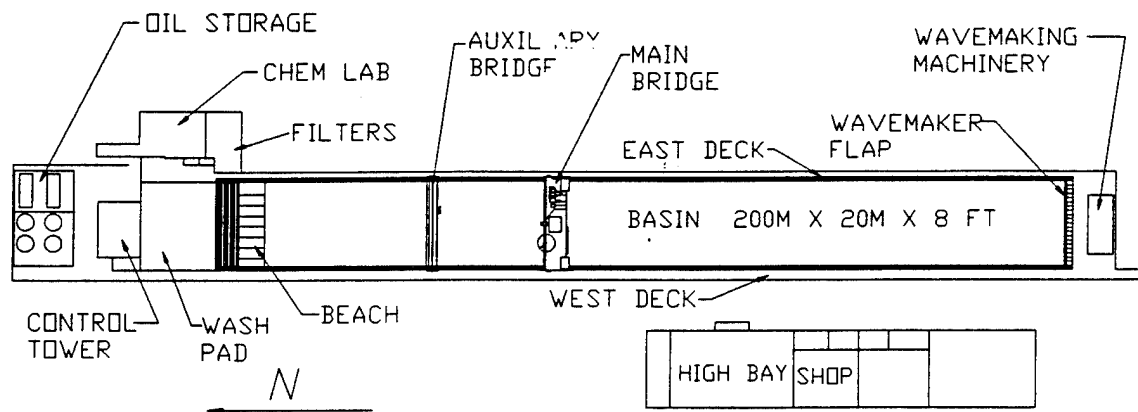

The Ohmsett Facility

Figure D-1 Overall Plan of Ohmsett Facility

CONVERSION FACTORS of IMPORTANCE at Ohmsett

(* means "by definition")

LENGTH

1	meter	=	3.281	ft
1	ft	=	0.305	m
1	Nautical Mile	=	6076.1	ft
	"	=	1852.0*	m

VOLUME

1	liter	=	0.001	m ³
1	gallon	=	3.785	liters
	"	=	0.003785	m ³
	"	=	0.133681	ft ³

VOLUME FLOWRATE

1	gallon/min	=	0.2271	m ³ /hr
		=	8.0208	ft ³ /hr
1	m ³ /hr	=	4.403	gal/min

VELOCITY

1	m/sec	=	3.281	ft/sec
1	ft/sec	=	0.3048*	m/sec
1	m/sec	=	3.281	ft/sec
1	m/sec	=	1.944	knots
1	knot	=	0.514	m/sec
1	ft/sec	=	0.592	knots
1	knot	=	1.688	ft/sec

DYNAMIC VISCOSITY

1	poise	=	1.0*	g/cm-sec
1	centipoise	=	0.01	g/cm-sec
1	kg/m-sec	=	10.0	poise
	"	=	1000	centipoise (cPs)

KINEMATIC VISCOSITY

1	stoke	=	1.0*	cm ² /sec
1	centistoke	=	0.01	cm ² /sec
		=	1.0	mm ² /sec
1	m ² /sec	=	10,000	stokes
		=	10 ⁻⁶	centistokes (cSt)
1	ft ² /sec	=	92903.04	cSt
1	in ² /sec	=	645.16	cSt

(The kinematic viscosity of fresh water is approximately 1 cSt ($\approx 10^{-5}$ ft²/sec) at 20°C)

Dividing dynamic viscosity in cPs by density in g/cc gives kinematic viscosity in cSt (note: density in g/cc is numerically equivalent to Specific Gravity)