

Final Report 1994

ONR Grant N00014-93-1267

EXPERIMENTAL APPARATUS FOR A MULTI-PURPOSE LASER/OPTICS LABORATORY AT TENNESSEE STATE UNIVERSITY

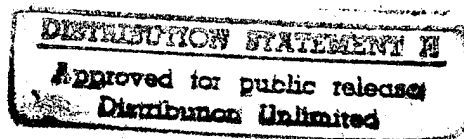

Principal Investigator: Patricia G. Hull

Tennessee State University

Department of Physics, Mathematics and Computer
Science

September 30, 1993 to August 30, 1994

19960520 017

DETC QUALITY INSPECTED

REPORT DOCUMENTATION PAGE

FORM APPROVED
OMB No. 0704-0188

Public reporting burden for this collection of information is estimated to average 1 hour per response, including the time for reviewing instructions, searching existing data sources, gathering and maintaining the data needed and completing and reviewing the collection of information. Send comments regarding this burden estimate or any other aspect of the collection of information, including suggestions for reducing the burden to Washington Headquarters Services, Directorate for Information Operations and Reports, 1215 Jefferson Davis Highway, Suite 1204, Arlington, VA 22202-4302 and to the Office of Management and Budget, Paperwork Reduction Project (0704-0188), Washington, DC 20503

| | | |
|----------------------------------|---------------------------|--|
| 1. AGENCY USE ONLY (Leave blank) | 2. REPORT DATE 29Dec95 | 3. REPORT TYPE AND DATES COVERED Final Technical Report 30Sept93, 30Aug94 |
|----------------------------------|---------------------------|--|

| | |
|---|--|
| 4. TITLE AND SUBTITLE OF REPORT Experimental Apparatus for a Multi-purpose Laser/Optics Laboratory (Laser/Optics Research Lab) | 5. FUNDING NUMBERS N00014-93-1-1267 |
| 6. AUTHOR(S) Patricia G. Hull | |

| | |
|---|---|
| 7. PERFORMING ORGANIZATION NAME(S) AND ADDRESS(ES) Tennessee State University 3500 John Merritt Boulevard Nashville, TN 37209-1561 | 8. PERFORMING ORGANIZATION REPORT NUMBER: none |
|---|---|

| | |
|---|---|
| 9. SPONSORING/MONITORING AGENCY NAME(S) AND ADDRESS(ES) Office of Naval Research, Code 252B-BDG Ballston Tower One 800 North Quincy Street Arlington, VA 22217-5660 | 10. SPONSORING/MONITORING AGENCY REPORT NUMBER: |
|---|---|

11. SUPPLEMENTARY NOTES:
Scientific Officer: Steve Ackleson, Code 323

| | |
|---|------------------------|
| 12a. DISTRIBUTION AVAILABILITY STATEMENT Unlimited | 12b. DISTRIBUTION CODE |
|---|------------------------|

RESTRICTION STATEMENT A
Approved for public release
Distribution Unlimited

13. ABSTRACT (Maximum 200 words)

The grant provided state-of-the-art experimental apparatus for measuring the scattering of polarized light, and supplemented existing equipment to enable faculty and students at TSU to carry out experiments in ionization spectroscopy. The light scattering apparatus we purchased allowed us to add an important experimental component to our successful theoretical research program for the Office of Naval Research (Environmental Optics). Much of the equipment, optical components, and detectors are multi-purpose and are used with both the scattering apparatus and the spectroscopy set-up. Ongoing experiments using the light scattering equipment include the measurement of the Mueller matrix elements for marine micro-organisms. A student, now in graduate school, used tunable diode laser to measure hyperfine splitting the $5^2S_{1/2}$ and $5^2P_{3/2}$ states of the isotopes of ^{87}Rb and ^{87}Rb .

| | |
|-------------------|-------------------------|
| 14. SUBJECT TERMS | 15. NUMBER OF PAGES: 16 |
| | 16. PRICE CODE |

| | | | |
|---|--|---|----------------------------------|
| 17. SECURITY CLASSIFICATION OF REPORT: unclassified | 18. SECURITY CLASSIFICATION OF THIS PAGE: unclassified | 19. SECURITY CLASSIFICATION OF ABSTRACT: unclassified | 20. LIMITATION OF ABSTRACT: none |
|---|--|---|----------------------------------|

**TITLE: EXPERIMENTAL APPARATUS FOR A MULTI-PURPOSE
LASER-OPTICS LABORATORY AT TENNESSEE STATE UNIVERSITY**

PRINCIPAL INVESTIGATOR: Patricia G. Hull

INSTITUTION: Tennessee State University
 3500 John Merritt Boulevard
 Nashville, Tennessee 37209-1561
 Fax/Phone: (615) 963-5846
 Internet: phull@harpo.tnstate.edu

Purpose

The purpose of the project was to equip a multipurpose laser-optics research laboratory. The intent of this laboratory is twofold: to provide state-of-the-art experimental apparatus for measuring the scattering of polarized light, and to supplement existing equipment to enable faculty and students at TSU to carry out experiments in ionization spectroscopy. The light scattering apparatus we purchased allows us to add an important experimental component to our successful theoretical research program for the Office of Naval Research. The additional equipment purchased augments existing equipment to enabling us to do research in ionization spectroscopy. Much of the equipment, optical components, and detectors are multi-purposed and are used with both the scattering apparatus and with the spectroscopy set-up.

Tennessee State University's contributions to this project were; a newly renovated laboratory to house the equipment, two Macintosh Quadra 700 computers for data acquisition and analysis, a large laboratory work table and chairs, a computer workstation for the computer controller and printer for the light scattering apparatus, a power Macintosh for running FORTRAN and MATLAB programs, and a laser printer for report writing. TSU further demonstrated its commitment to support and promote quality research in the Department of Physics, Mathematics and Computer Science by supplementing this grants equipment budget by over \$4000.

Research Goals

Experimental projects planned for the light scattering apparatus include the measurement of Mueller matrix elements for polarized light scattering from marine micro-organisms, measurement of reflective and transmissive light scattering of aerogel, and measurement of reflective light scattering from cured polymeric and ceramic coating which safeguard microelectronic chips. The projects planned in spectroscopy include absorption, fluorescence, and multiphoton ionization spectroscopy using the dye laser or the diode laser.

One of the experimental projects planned for the laser-optics laboratory using the CASI light scattering apparatus is the measurement of the Mueller matrix elements of the scattering of polarized light by marine micro-organisms. The samples consist of coastal water taken from locations in northern portions of California, and samples of selected marine organisms cultured in the laboratory at LBNL. The Dr. Hull has been involved for several years with making similar measurements at Lawrence Berkeley Laboratory with a device developed by Arlon Hunt.⁴ This project provides the principal investigator, Dr. Patricia Hull, with an important experimental component to her successful analytical modeling of light scattering by marine organisms, a program currently supported by the Ocean Optics Section of the Office of Naval Research. Dr. Hull's experience at Lawrence Berkeley National Laboratory in light scattering measurements as well as her experience in mathematical modeling help her provide the students with an understanding of the effects that occur when polarizers and phase retarders are manipulated in an experimental apparatus, an understanding that is often lost when highly automated equipment is used by students.

Approach

Two types of experiments are planned, light scattering and ionization spectroscopy. The experiments fall into three categories:

- (1) Measurements of the Mueller scattering matrix elements requiring transmissive optics.
- (2) Measurements of surface defects or roughness requiring reflective optics.
- (3) Measurements in ionization spectroscopy.

1. Experiments In Light Scattering

The CASI light scattering apparatus will be used for the light scattering measurements. Its components are shown in Figure 1 and its specifications are described in Appendix A. The photoelastic modulator when used with the CASI allows for an efficient measurement of the sixteen elements of the Mueller scattering matrix. The CASI apparatus is computer controlled and highly automated so that it can be used successfully by undergraduate physics and engineering majors with limited laboratory experience. The basic system consists of four components:

- (1) A laser and its associated optics for producing a collimated and monochromatic beam of light with a particular polarization state.
- (2) A mounting table or holder that allows for linear and angular adjustment and/or two-dimensional raster scanning of the surface of the sample to be studied.
- (3) A detector and its associated optics such as polarizing filters, apertures, and lenses.

(4) A Computer system for collecting, analyzing and displaying the light scattering data. A typical experimental arrangement for measuring light scattering is shown in Figure 1.

COMPONENTS OF A BASIC LIGHT SCATTERING APPARATUS

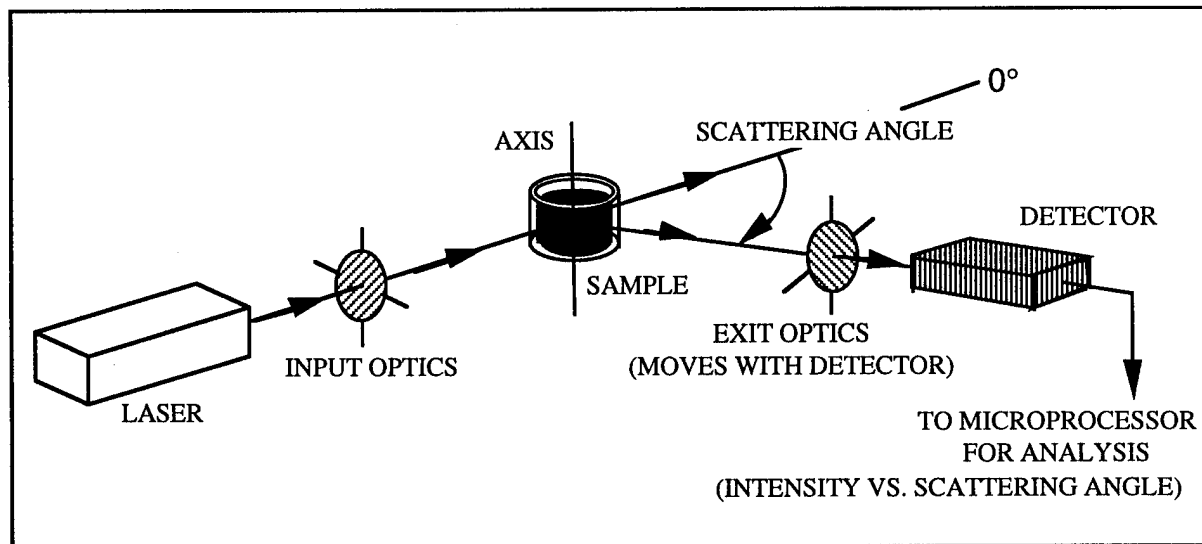

Figure 1. The experimental optical system used to measure all elements of the scattering matrix and polarization states. Input optics may include linear polarizing filters, photo-elastic matrix modulator, quarter-wave plates, etc. Exit optics may include linear polarizing filters and for some measurements, no filters.

It is capable of measuring, displaying, and analyzing light scatter from both reflective and transmissive optics. The laser light source is chopped, power referenced, spatially filtered and focused. Five degrees of freedom are provided to the sample; x, y, and z linear and two rotational axes. Their receiver head is mounted on the motorized stage and has adjustments for height, pitch and yaw. Measurements closer than 0.1° from specular can be made on most samples. Additionally, a low-noise programmable preamplifier is matched to the detector and followed by a lock-in amplifier to further reduce noise. Data measurement is made by sweeping the detector through the specular beam in the incident plane under computer control. As the data sweep progresses, the computer controls amplifier gain and filter changes as light intensity decreases. The background noise is measured separately and compared to the sample data. The operator controls data collection by choosing certain parameters in a setup module in the software package provided with the instrument. Analysis, formats, and surface statistics calculations, are also accomplished through the software provided with the instrument by TMA. Annotated results are printed on an ink jet printer as view graphs or publication ready figures.

MEASUREMENT OF MUELLER MATRIX ELEMENTS (TRANSMISSIVE OPTICS)

The Stokes Vector and Mueller Matrix Formalisms

The Stokes vector and Mueller matrix formalism suits our purposes well. This matrix formalism includes a description of the scattering from both polarized and unpolarized light. Another popular formalism, the Jones matrices cannot treat unpolarized light. The polarization states of the incident and scattered light are described by four-element Stokes vectors $\mathbf{F} = [I, Q, U, V]$, where I is the total intensity of light, Q represents vertical or horizontal polarization, U represents 45° polarization, and V represents circular polarization. In this formalism, the effect of a scattering medium on the beam may be represented by the matrix equation, $\mathbf{F}' = \mathbf{M} \mathbf{F}$. This is shown in terms of the matrix elements below:

$$\begin{pmatrix} I_s \\ Q_s \\ U_s \\ V_s \end{pmatrix} = \frac{1}{k^2 r^2} \begin{pmatrix} S_{11} & S_{12} & S_{13} & S_{14} \\ S_{21} & S_{22} & S_{23} & S_{24} \\ S_{31} & S_{32} & S_{33} & S_{34} \\ S_{41} & S_{42} & S_{43} & S_{44} \end{pmatrix} \begin{pmatrix} I_i \\ Q_i \\ U_i \\ V_i \end{pmatrix} \quad (1)$$

The matrix \mathbf{M} (with elements S_{ij}) is known as the Mueller or 'scattering' matrix. The subscripts i and s represent incident and scattered light, respectively. The elements of the scattering matrix depend on the scattering angle and contain all the elastic scattering information available at a given wavelength. They are functions of the size, structure, symmetry, orientation, complex refractive index, and ordering of the scatterers.

Physical Interpretation

A physical interpretation of the components of the Stokes vector is stated in terms of the intensity of light reaching a detector. The component, I , is the total intensity of light, Q , is proportional to the difference between the intensities of horizontal and vertical linearly polarized light, U is proportional to the difference between 45° and 135° linearly polarized light, and V is proportional to the difference between the intensities of right and left circularly polarized light^{1,2} measurements. A formal discussion is presented in Appendix C which also contains a brief interpretation of the individual elements.

The determination of all sixteen of the Mueller matrix elements requires a number of measurements. One scheme presented by Bickel and Bailey,³ is often used by researchers for determining all of the elements by series of measurements of intensity and is functionally

equivalent to the scheme used in the TMA apparatus. The first step is to set up a detector to measure the total intensity scattered from a sample illuminated with horizontally polarized light. The measured polarization intensity, I_{oh} , connects the matrix elements S_{11} and S_{12} giving $I_{oh} = S_{11} + S_{12}$. When the input polarizer is rotated by 90° to illuminate the sample with vertically polarized light, the detector measures the polarization intensity, I_{ov} , which connects the same two elements, but with $I_{ov} = S_{11} - S_{12}$. The two measurements of intensity made as a function of scattering angle are then 'solved' for S_{11} and S_{12} by the computer software. Additional measurements of intensity with different combinations of input and exit filters can be made and with algebraic manipulation will yield all 16 matrix elements. Not all the matrix elements are independent, so about eight intensity measurements vs. scattering angle are necessary with Bickel and Bailey's scheme.

An improvement on this scheme was made by Hunt⁴ with a polarization-modulated nephelometer. His method employs a photo-elastic modulator vibrating at 50 kHz and a matching two-phase lock-in amplifier. All sixteen Mueller matrix elements can be determined with four intensity vs. angle measurements. This instrument was used successfully by Voss and Fry⁵ in their measurements of light scattering by ocean water. We plan to modify TMA's apparatus to take advantage of Hunt's more efficient method for our measurements of transmissive light scattering at TSU.

MEASUREMENT OF SURFACE ROUGHNESS (REFLECTIVE OPTICS)

One of our experimental projects in reflective optics will be to measure light scattering from cured polymeric and ceramic coating which safeguard microelectronic chips. This study will characterize samples as to their surface impurities, cracks, pits and other structural damage not readily visible by ordinary microscope. This project essentially involves deducing the 'roughness' of the coating on the microchip from the measurement of the scattering of polarized light. Linearly or circularly polarized light are special cases of elliptically polarized light, a more general description of the polarization state. For this reason, the study of polarized light scattering is often called ellipsometry.

Another experimental project that will take advantage of the equipment is the study of both the surface properties and the transmission properties of aerogel, a porous and very low density form of silica. A number of samples of aerogel were made by Dr. Hull on her visits to Lawrence Berkeley Laboratory (LBNL) and she has access to samples currently being made there. Dr. Hull is particularly interested in how the aerogel is affected by aging.

Describing Surface Roughness

Surface roughness is generally defined to be variations in height (or depth) from an average surface level. Factors contributing to surface roughness are: foreign objects on the surface such as dirt, random unevenness, films, cracks, pits, ridges, scratches, and regular (periodic) grooves or features. These features can range in size from a few angstroms, up to a visible scratch whose width could be measured in microns.

Generally, we will be interested in surface irregularities or defects with features on the order of the size of wavelengths of visible light. Features this small are not readily visible to the unaided eye and are often not easily observed by examination of the surface with an optical microscope.

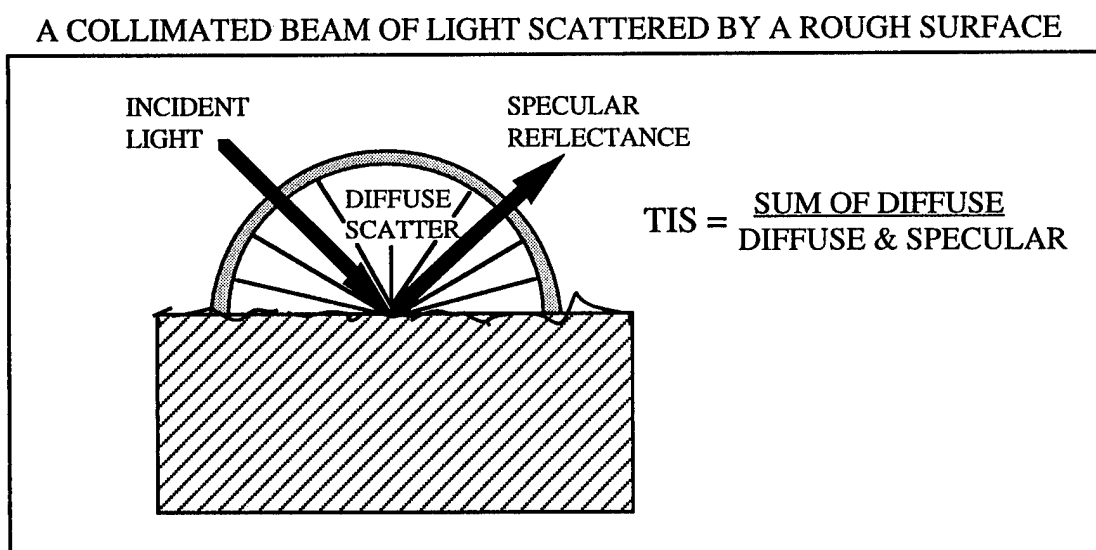

Figure 2. Light reflected from a surface. The scattered light (diffuse reflections), amplitude and angular distribution is determined by surface roughness.

A surface can be specified by a number of parameters that consider its roughness in terms of deviations from the mean surface level. One of the most common parameters is RMS roughness defined as the root mean squared value of all vertical deviations from the mean surface level. Unfortunately, detailed information about the surface is often lost in the "averaged" nature of this parameter. For example, sand paper and a phonograph record may have the same RMS roughness but they obviously have very different surface characteristics.

The distribution of roughness versus spatial frequency of features defined by the Power Spectral Density function (PSD) or Power Spectrum provides information about periodic features, so

sandpaper would have a random distribution of power vs. frequency, whereas the phonograph record would display at least one dominant frequency or a 'spike' in a PSD plot.

Determination of Surface Roughness from Light Scatter

Surface roughness causes incident light to be scattered in directions other than the specular reflection direction. Clearly the rougher the surface, the higher the proportion of incident light scattered. The scattered light is defined by its magnitude and its angular distribution, both of which may be used to derive important surface roughness data.

There are two commonly accepted measurements used to quantify these functions: Total Integrated Scatter (TIS) and Bi-directional Reflectance Distribution Function (BRDF). For a reflective surface, TIS is defined as the ratio of the total scattered power to the total reflected power. To a first approximation, TIS is related to RMS roughness by the equation;

$$\text{TIS} = (4\pi\sigma/\lambda)^2, \quad (2)$$

where σ is the RMS roughness, and λ is the wavelength of the light being scattered.

BRDF is determined from the ratio of the scatter per unit solid angle to the incident power, *i.e.* normalized scatter density. BRDF is commonly presented as a function of angle. This function contains valuable information about the amplitude and width of the surface features. The amount of scattered light is a result of the amplitude of the scattering features, whereas the scatter angular distribution is a result of the surface spatial frequency.

TIS is a good yardstick by which to measure surface roughness, but it is the angular distribution, as defined by the BRDF, which carries additional information about the distribution, shape and size of surface imperfections. If diffraction theory is used to accurately relate the surface PSD to the BRDF, the two functions are nearly proportional, which makes a determination of surface parameters from the BRDF straightforward. Additionally, simple integration of the PSD results in RMS roughness values of the surface over a selected range of surface wavelength.

In a technical report written for TMA Industries, Stover, Rifkin and Cady,⁶ demonstrate the feasibility of light scatter techniques to detect, locate, and map subsurface defects in semiconductor wafers. In a second technical report for TMA, Stover and McGary,⁷ show that by cross-polarizing the source and the receiver, it is possible to eliminate surface scatter and measure the BRDF resulting from the contaminants and subsurface defects.

At TSU, we will follow closely the approaches used in these technical reports to carry out our surface studies. We will begin the characterization of a sample surface by directing a collimated beam of laser light onto the surface. The input optics shown in Figure 1 will generally consist of a linear polarizer, although a quarter-wave plate with its fast axis $+45^\circ$ to a horizontally polarized beam to produce circularly polarized light will be used in some applications. The researcher will select the angle of incidence on the sample surface. The scattered light will pass through some optics and its intensity will be measured by an array of detectors (or a single detector) which moves in an arc relative to the surface. The integral microprocessor will then use measurements of BRDF and TIS to determine RMS and PSD. The illuminated spot size may be fixed or variable as the particular sample dictates. In some cases, the sample will be scanned, while in other cases random testing of several spots will be made.

2. Experiments In Ionization Spectroscopy

Many experiments can be carried out in ionization spectroscopy with the equipment purchased with this grant. Experiments using a Nitrogen-pumped tunable dye laser and a heat pipe have been described in the literature and several of these experiments have appeared in undergraduate laboratory manuals in physical chemistry. The measurement of the absorption, fluorescence, and multiphoton ionization spectroscopy of Sodium, multiphoton ionization of Cesium, multiphoton, laser fluorescence, and lifetime measurements of Iodine, absorption and resonance ionization spectroscopy of Cesium using a blue dye for ground state transitions, and temperature dependent lifetime measurements of Phosphors excited with the Nitrogen laser have been carried out with comparable equipment.

It is our intention to do original research, of course, but measurements of the multiphoton ionization of Iodine and Cesium serve as excellent examples of the experimental procedure and equipment required for the experiment. An efficient laboratory arrangement designed by Charles Feigerle, Deborah Glover and Robert Compton of the University of Tennessee allows the two experiments to be carried out with one set-up as shown in Figure 3. By removing the flat mirror shown in the figure, the laser beam is focused into the Iodine cell and multiphoton ionization of Iodine is measured. With the mirror in place, the laser beam is focused into the heat pipe containing Cesium, and its ionization spectrum is measured. A more detailed diagram of a Cesium heat pipe used in this experiment is shown in figure 4. A complete description of the experimental procedure used in this measurement of the multiphoton ionization of Cesium can be found in a laboratory manual in physical chemistry.⁸ This experiment will be used as a training tool to familiarize the students with the equipment and to prepare them for original and independent research. (Figures 3 and 4 have been used in this proposal with permission of Charles Feigerle.)

Description of an Experimental Set-up

The basic apparatus used for both experiments shown in Figure 3. consists of a dye laser pumped by a 2 Megawatt pulsed nitrogen laser, a vacuum (10^{-3} Torr) and gas handling system for cell preparation, and ionization detection electronics. Components shown in the figure that are requested in this proposal are heat pipes and other appropriate sample cells, and the detection electronics except for the computer. Prepared sample cells are available from Comstock, Inc. of Oak Ridge, TN. The detection system consists of a Tektronix Model TDS 320 real-time oscilloscope, a Stanford Research Systems Model SR250 boxcar averager, LabVIEW analog to digital conversion computer hardware and data collection software, and additional computer software for data analysis and presentation. The noise in the output signal, due mostly to variations in laser pulse intensity, is reduced significantly by integrating the signal over a narrow window near the peak and averaging the resultant over a few shots of the laser with the boxcar averager.

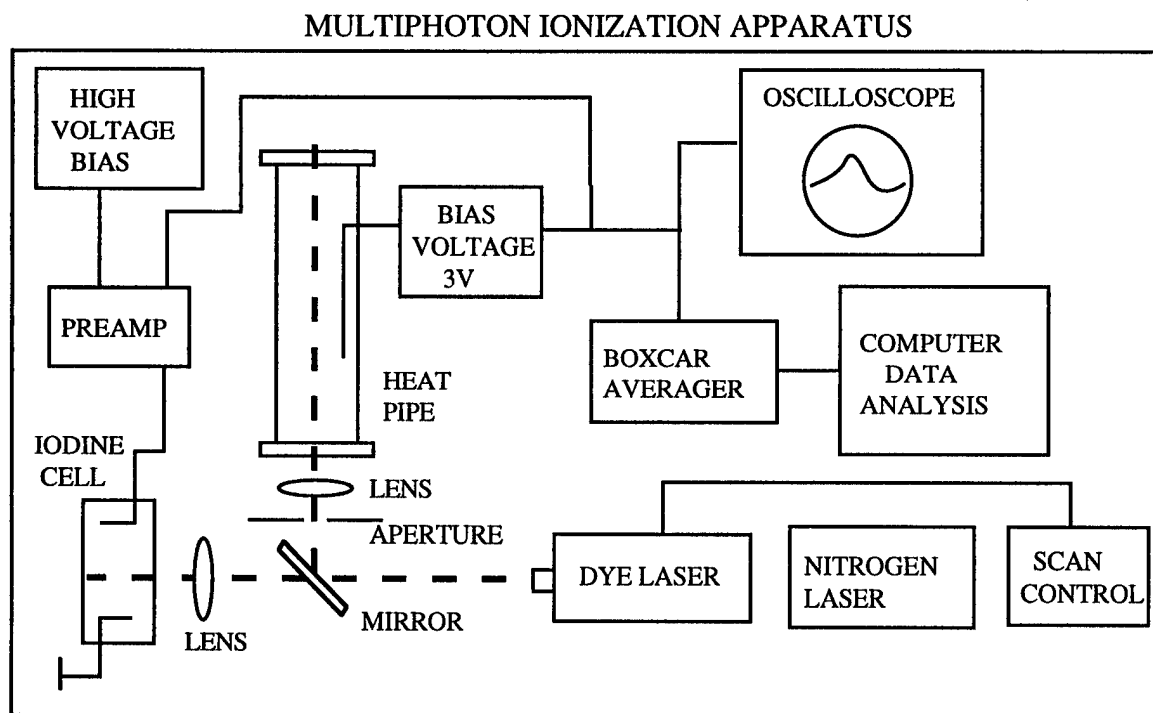

Figure 3. Block diagram of the components used to perform multiphoton ionization spectroscopy. The dashed line represents the laser beam path and the solid lines the electrical connections.

The experimental apparatus that we have assembled with this grant is amenable to undergraduate student use. The nitrogen laser is extremely simple to operate. However, tuning the optical

elements in the dye laser requires some experience and expertise. Some training and faculty supervision is required before the student can be expected to master making dye changes and subsequent adjustments to the dye-laser. Different laser dyes are required as different sample are studied in order to match the wavelengths of the sample's spectrum. The wavelength produced by the dye laser, for a given dye, is motor controlled through a digital programmer which is easily operated by a student. The data collection and analysis computer programs for the Macintosh is easy to use and requires very little training.

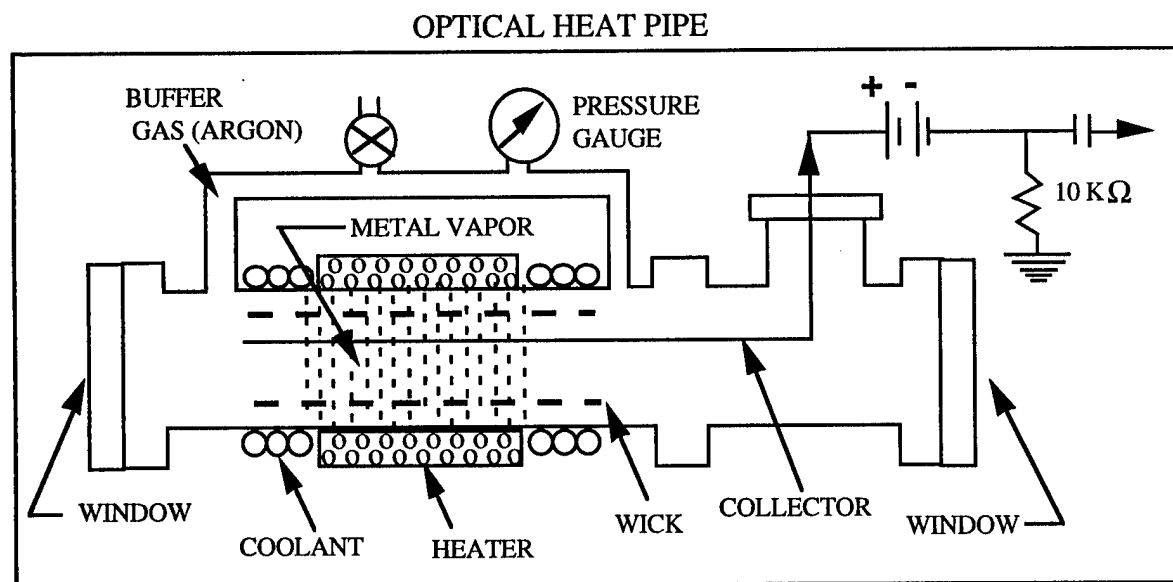

Figure 4. Diagram of a heat pipe used in the multiphoton ionization experiment. The laser beam passes through the length of the pipe and is focused in the metal vapor to produce ionization. The ions or electrons that are produced are drawn to the collector where their current pulse can be measured.

Accomplishments

If we are to develop a valid model to describe light scattering from marine organisms, it is important to have an experimental component of the modeling at TSU. It is not only costly to take students to LBNL, but it gives them the impression that research is too difficult for them to do at their home institution. The Equipment (listed in Appendix B and Appendix C) that we have purchased for the laser/optics research lab allows students to do high quality research at their home institution. A diagram of the laboratory area is shown in Appendix D. Since the lab is located in a familiar environment, it helps build the student's confidence and encourages him/her to continue in his career in science. Until Dr. Hull initiated her research program for ONR about eight years ago, there had been no research in physics in at least twenty years, and no students graduated in physics for several years. By the end of the spring semester of 1996, we will have graduated nine

physics majors (five of them minority) who have been a part of our research in light scattering. Clearly, we have demonstrated that our students are capable of doing research, and that we can help increase the participation of minority students in science by providing them with research opportunities. Students who have participated in the training and use of equipment supplied by this grant are:

1. Frank Allen* (May 93) - Used light scattering apparatus at LBNL for his senior project. He has completed course-work and is beginning his PH.D. dissertation in optics at Alabama A & M .
2. Curtiss Cathey* (Aug 93) - Now at Ohio State University working on a Master's degree in Mechanical Engineering. Demonstrated chaotic systems for senior project.
3. Suresh Kari (Aug 93) - Finishing a Master's degree in bio-medical technology and currently enrolled in medical school at University of Memphis. Did senior project in the School of Engineering.
4. Mark Sweazey (May 94) - Built the tunable diode laser for his senior project. Working toward a Master's degree in Computer Science at Middle Tennessee State University. He also works part-time at TSU as a laboratory instructor.
5. Felicia Shaw* (May 94) - For senior project measured the Mueller Matrix elements for light scattering by *Bacillus Subtillus*. Works for an environmental engineering firm using light scattering as a tool in measuring air quality.
6. Titus Berry* (May 95) - Wrote a theoretical paper on Mueller Matrix elements for senior project. Pursuing a Master's degree in Science Education at TSU.
7. Joe Vital (May 95) - Used tunable diode laser to measured hyperfine splitting in the $5^2S_{1/2}$ and $5^2P_{3/2}$ states of the isotopes of $_{35}\text{Rb}^{87}$ and $_{37}\text{Rb}^{87}$ for senior project. Pursing a Ph.D. degree in physics at University of Alabama.
8. John Frogge (Dec 95) - Tested an artificial neural network for determining the size parameter of particles from light scattering data for senior project. Plans to attend graduate school in fall of 1996. Is currently working as a physics laboratory instructor at TSU.
9. Miguel Hayes* (May 96) - Measured Mueller Matrix elements of 1.0 micron latex spheres and compared results with Mie calculations. Has not decided between attending graduate school in science education or working in industry for a year.

* Minority Student

References

1. H. van de Hulst, *Light Scattering by Small Particles*, Wiley, New York, 1957.
2. M. Kerker, *The Scattering of Light and Other Electromagnetic Radiation*. Academic Press, New York, 1969.
3. W. Bickel and W. Bailey. "Stokes vectors, Mueller matrices and polarized scattered light," *Am. J. Phys.* , Vol. 53, 468-478, 1985.
4. A. Hunt and D. Huffman. "A new polarization-modulated light scattering instrument," *Rev. Sci. Instrum.*, Vol. 44, 1753-1762, 1973.
5. K. Voss and E. Fry, "Measurement of the Mueller matrix for ocean water," *Appl Opt.*, Vol. 23, No.23, p.4427, Dec. 1984.
6. J. Stover, J. Rifkin, and F. Cady. "Detection of process induced damage by subsurface scatter measurement," TMA Technologies, Inc., Technical Report, Jan. 1988.
7. J. Stover and D. McGary. "Scatter from subsurface defects and contaminants," TMA Technologies, Inc., Technical Report, June, 1990.
8. C. Feigerle and R. Compton. "Multiphoton Ionization of Cesium," *Physical Chemistry Developing a Dynamic Curriculum*, Edited by Richard Schwenz and Robert J. Moore, Pub. by Amer. Chem. Soc. Press, Washington, D.C., 1993, p178-193.
9. P. Hull, A. Hunt, M. Quinby-Hunt, and D. Shapiro, . "Coupled-dipole Approximation as an analytical Model for Predicting Scattering from Marine Micro-organisms," American Geophysical Union 1990 Fall Meeting in San Francisco.
10. P. Hull, A. Hunt, M. Quinby-Hunt and D. Shapiro, "An analytical model for predicting light scattering from marine micro-organisms," Proc. SPIE, Vol. 1537, San Diego, July 1991.
11. D. Shapiro, M. Quinby-Hunt, A. Hunt and P. Hull, "Circular polarization effects in the light scattering from single and suspensions of dinoflagellates," SPIE Proceedings, Vol. 1537, San Diego, July 1991.
12. A. Hunt, M. Quinby-Hunt, D. Shapiro, and P. Hull. "Depolarization of Circularly-Polarized Light Scattered from Different Species of Dinoflagellates," American Geophysical Union 1990 Fall Meeting in San Francisco.
13. D. Shapiro, P. Hull, A. Hunt, Y. Shi, W. McClain, M. Maestre, M. Quinby-Hunt, and J. Hearst. "Towards a working theory of polarized light scattering from helices." Submitted to *J. Chem.Phys.* DEC. 1992.

APPENDIX A

CASI™ Specifications

TMA Technologies, Inc.
P. O. Box 3118
Bozeman, Montana 39715
Phone (406) 536-7684 FAX (406) 587-1428

Laser Light Sources

(1) HeNe laser light source: The HeNe laser is mounted in a modular cabinet and provides a nominal 5 mW power at a wavelength of 633 nm.

(2) Diode laser: The diode laser is mounted in the same cabinet as the HeNe. It operates at power of about 5 mW and a wavelength of 1320 nm. Since the beam is in the infrared, the HeNe laser is used to assist in the focussing and alignment of the diode laser beam.

(3) Argon laser light source mounted in a modular cabinet. The Argon laser is air cooled and provides 15-20 mW at wavelengths of 488 and 514 nm.

The above three laser light sources are computer controlled and computer monitored. Beam focusing and spot size are controlled to less than 0.5 mm.

Sample Holder

The TMA system provides six sample degrees of freedom to high precision. Additionally, sample rotation about the vertical axis is under computer control. Sample X and Y translation stages are provided with 150 mm x 130 mm of travel under computer control. Standard sample size is < six inches in diameter.

Goniometer

The goniometer (rotary stage) has an adjustable arm from 150 mm to 500 mm to accommodate even short focal length optics. It is motorized with computer control and has a 360° range with mounting for the photo detector at the end of the arm. This mounting provides for easy interchange of various photo detectors. Resolution of the rotary stage is 0.001°.

Receiver

To successfully measure high quality optics, 13 to 14 orders of magnitude (BSDF) measuring capabilities are essential. Amplifier gain switching, aperture selection and filter changing are necessary for this level of performance. The TMA system automates all of these functions during data acquisition by executing user configured parameters.

The detector assembly (receiver) includes motorized aperture changing and electronic gain changing over 13 to 14 orders of magnitude. In addition, it includes a lens, bandpass filter, and an adjustable field stop to limit field of view. This is essential to reduce instrument noise (signature) near specular.

Computer System

TMA CASI™ Analysis Software is 100% compatible with other software that we use for data analysis and presentation. We can share data files directly with LBNL, and use the **TMA** Analysis routine on their data.

Overall System Specifications

Scan time is highly dependent on sample characteristics. The **TMA CASI™** will scan the lowest scatter, state of the art reflective optics as per specifications in 10 minutes or less. Diffuse reflective materials will be scanned by the **TMA CASI™** in less than one minute under the specified conditions. **TMA** systems are routinely used to measure in excess of 50 samples per day. This is the result of ease of alignment and set up as well as measurement speed.

The system will be linear to less than 3% from 5×10^{-8} to $5 \times 10^{+6}$ (steradian)⁻¹ of scatter intensities.

The following specifications apply to operation at 0.63 μm . Electronic noise of the **TMA** system is less than 5×10^{-8} (steradian)⁻¹ with the largest aperture. Instrument signature is less than 1×10^{-5} (steradian)⁻¹ at 2 and less than 5×10^{-8} (steradian)⁻¹ at 10. The **TMA CASI™** instrument signature is also less than or equal to 1×10^{-2} at 1 and less than or equal to 1 at 0.1. These levels are essential to measure current state of the art optical surfaces which can be as low as 10^{-7} (steradian)⁻¹ at high angles.

Reproducibility of the **TMA** system is 1% or better on repeated scans at the same sample location from 5×10^{-8} to $5 \times 10^{+8}$ in a clean environment.

TMA CASI™ is fully compatible with the recent government sponsored ASTM standard of BRDF measurements.

APPENDIX B. Equipment List

| ACCOUNT NO. | 532195 | | | | | |
|-------------------------|----------|--------------|------------------|--------------|-------------------------------|--|
| Source | PO date | PR/PO # | total amt of req | Grand Total | Description | |
| TMA Technology, Inc. | 10/1/93 | 47706/114959 | \$122,130.00 | \$122,130.00 | CASI Scatterometer | |
| Hinds Instruments | 11/1/93 | 47707/114404 | \$4,822.85 | \$126,952.85 | photo-elastic modulator | |
| Edumund Scientific | 11/19/93 | 47710/115987 | \$705.74 | \$127,658.59 | laser safety glasses | |
| Kinetic Systems | 11/24/93 | 47736/115594 | \$3,575.00 | \$131,233.59 | optical table | |
| Tektronics Inc. | 11/24/93 | 47738/116815 | \$2,275.75 | \$133,509.34 | digital oscilloscope | |
| Engineering Tech. Inst. | 12/6/93 | 47733/115955 | \$985.00 | \$134,494.34 | laser safety course | |
| Office Depot | 12/20/93 | 47734/115888 | \$219.98 | \$134,714.32 | Safety panel/chair | |
| Bluff City Electronics | 1/7/94 | 47740/116096 | \$120.00 | \$134,834.32 | temperature probe | |
| T-Baker Machinery | 1/18/94 | 47739/116001 | \$800.00 | \$135,634.32 | installation of optical table | |
| The Mathworks Inc. | 1/28/94 | 47741/116436 | \$585.00 | \$136,219.32 | computer analysis software | |
| Micro Imaging Inc | 2/2/94 | 44742/116929 | \$15,819.85 | \$152,039.17 | phase contrast microscope | |
| Spyglass Inc. | 2/16/94 | 47746/116490 | \$499.00 | \$152,538.17 | Computer Analysis software | |
| Comstock Inc. | 3/17/94 | 47749/118311 | \$10,320.00 | \$162,858.17 | heat pipe/ionization cell | |
| TMA Technology, Inc. | 3/17/94 | 88658/117459 | \$496.00 | \$163,354.17 | polarizers | |
| Laser Photonics | 3/30/94 | 88689/118312 | \$22,136.00 | \$185,490.17 | pulsed laser/dye laser | |
| Tech. Mfg. Corp. | 5/12/94 | 88686/119170 | \$865.00 | \$186,355.17 | lightweight breadboard | |
| Comstock Inc. | 5/16/94 | 98343/119158 | \$750.00 | \$187,105.17 | vacuum manifold | |
| K Street Systems | 5/17/94 | 98342/118387 | \$458.00 | \$187,563.17 | Computer Software | |
| C-Squared Corp. | 5/18/94 | 98344/118519 | \$827.00 | \$188,390.17 | Microscope lighting | |
| Kinetic Systems | 5/25/94 | 98345/119171 | \$2,639.95 | \$191,030.12 | optical components | |
| Duke Scientific Corp. | 5/23/94 | 88692/119169 | \$1,070.00 | \$192,100.12 | microsphere standards | |
| Shields Elect. Sup. | 5/31/94 | 98348/118787 | \$747.88 | \$192,848.00 | IR Video camera | |
| Stanford Rsch. | 6/25/94 | 47712/11944 | \$750.00 | \$193,598.00 | lock-in amplifier | |
| Melles-Griot | 6/27/94 | 98332/118995 | \$708.00 | \$194,306.00 | beam-splitting polarizer | |
| National Instruments | 7/1/94 | 98347/118518 | \$3,000.00 | \$197,306.00 | LabView software | |
| Cole-Parmer | 7/12/94 | 98335/120663 | \$737.60 | \$198,043.60 | lab supplies | |
| Hellma Cells Inc. | 7/20/94 | 98336/120161 | \$1,969.50 | \$200,013.10 | Scattering cells | |
| Oriel Corp. | 7/21/94 | 98333/119773 | \$819.00 | \$200,832.10 | polarizers (514 & 633 nm) | |
| National Instruments | 7/27/94 | 98345/119171 | \$4,139.50 | \$204,971.60 | Data acquisition hardware | |
| | | | Total Budget | \$205,000.00 | | |

APPENDIX C. List Of Equipment Purchased With This Grant

1. Complete light scattering system
CASI™ Scatterometer Model C3-3 (See Appendix A for complete specifications)
2. Nitrogen Laser Pumped Tunable Dye Laser System (Laser Photonics)
3. Photoelastic Modulator & Controller
PEM-90™ MODEL 1/FS50 Fused Silica, 50 kHz
Anti reflective coating, 450-650 nm, broad band on 1/FS50
PEM-90C Controller
Model GPIB (IEEE-488 Interface & Adapter cable)
4. Lock-in amplifier
Stanford Research Systems SR850 DSP Lock-In Amplifier
5. Boxcar averager (Comstock)
6. Oscilloscope
Tektronix Model TDS 320 100 MHz Digital Real-time Oscilloscope
7. Computer Software/Hardware
LabVIEW 2 Computer Software for Macintosh
NB-MIO-16 (Multifunction Analog & Digital I/O Interface)
NB-DMA-8-Gm (DMA Controller & IEEE-488 Interface)
CB-5 I/O Connector Block & Adapter Cable Assembly
MacDSP Lab Special Package Offer
(includes MacDSP board with A/D and D/A, Signal Analyzer/QT
LabVIEW extensions, MatLab extensions, IP Lab extensions,
and Array Processing Library)
MATLAB Computer Software
Three MATLAB "Toolbox" special applications packages
"Spyglass: Transform, Dicer and Format"
8. Sample Cells and Auxiliary Components
Heat Pipe, 76 cm, quartz windows (Comstock)
Temperature controller for heat pipe (Comstock)
Pressure controller & gauge for heat pipe (Comstock)
Ionization Cell (Comstock)
Scattering Cells (Hellma)
9. Olympus Phase-contrast optical microscope with Camera Attachment
(Micro Imaging Inc.)
10. Miscellaneous Supplies
Vibration-damping optical table, 4'x 8'
laser safety glasses (3 pr.)
computer tutorial in laser safety
mounts, holders, cables, connectors, etc.

APPENDIX D. Layout of Research Laboratory

