

NASA CONTRACTOR
REPORT

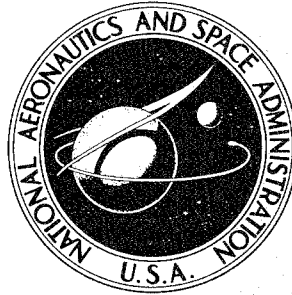

NASA CR-640

NASA CR-640

DISTRIBUTION STATEMENT A
Approved for public release
Distribution Unlimited

RESEARCH STUDY TO PROVIDE CONCEPTS OF
PANEL ATTACHMENT MECHANISMS SUITABLE
FOR REFURBISHABLE PANEL APPLICATION

by R. E. Rieckmann

Prepared by
MARTIN COMPANY
Baltimore, Md.
for Langley Research Center

19960516 052

DTIC QUALITY INSPECTED 1

NATIONAL AERONAUTICS AND SPACE ADMINISTRATION • WASHINGTON, D. C. • NOVEMBER 1966

DEPARTMENT OF DEFENSE
PLASTICS TECHNICAL EVALUATION CENTER
PICATINNY ARSENAL, DOVER, N. J.

PLASTIC 12343

RESEARCH STUDY TO PROVIDE CONCEPTS OF PANEL ATTACHMENT
MECHANISMS SUITABLE FOR REFURBISHABLE PANEL APPLICATION

By R. E. Rieckmann

Distribution of this report is provided in the interest of
information exchange. Responsibility for the contents
resides in the author or organization that prepared it.

Prepared under Contract No. NAS 1-5253 by
MARTIN COMPANY
Baltimore, Md.

for Langley Research Center

NATIONAL AERONAUTICS AND SPACE ADMINISTRATION

For sale by the Clearinghouse for Federal Scientific and Technical Information
Springfield, Virginia 22151 - Price \$2.50

CONTENTS

	Page
Table of Contents	iii
Illustrations	iv
Summary	1
Introduction	1
List of Symbols	3
System Compatibility	4
Preliminary Attachment Mechanism Concept Survey	6
Thermostructural Panel Environment and Design Criteria	6
Preliminary Thermal and Structural Studies	9
Evaluation and Selection of Recommended Concept	13
Panel Design and Sensitivity Studies	18
Detail Study of Selected Refurbishment Concept	19
Structural Design Conditions	19
Structural Analysis	21
Sensitivity of Refurbishable Panel System	31
Recommended Refurbishable Panel System	33
Conclusions and Recommendations	35
References	38

ILLUSTRATIONS

<u>Figure</u>	<u>Title</u>	<u>Page</u>
1	Representative Hatch Hinge Scheme with Refurbishable Panel and a Local Access Concept	39
2	Heatshort Study	40
3	Insulation Conductivity/Thickness Interaction	41
4	Weight and Volumetric Penalty for Plastic and Steel Standoff to Maintain 610° R (338° K) Vehicle Structural Temperature	42
5	Flexible Clip Stresses [steel substrate with steel clips, temperature = 1260° R (700° K), pressure = 2.73 psi (18.1 kN/m ²)]	43
6	Flexible Clip Stresses [phenolic/glass substrate and clip, temperature = 1260° R (700° K), pressure = 2.73 psi (18.1 kN/m ²)]	44
7	Panel Attachment	45
8	Required Support Spacing - Ablator - NASA 602 - 585° R (325° K)	48
9	Required Support Spacing - Ablator - LDNP - 585° R (325° K)	49
10	Required Support Spacing - Ablator - NASA 602 - 740° R (411° K)	50
11	Required Support Spacing - Ablator - LDNP - 740° R (411° K)	51
12	Required Support Spacing - Ablator - NASA 602 or LDNP - 1080° R (600° K)	52
13	Required Support Spacing - Ablator - NASA 602 or LDNP - 1260° R (700° K)	53
14	Effects of Vehicle Hard Point Spacing	54
15	Selected Refurbishable Panel Concept	55

ILLUSTRATIONS (continued)

<u>Figure</u>	<u>Title</u>	<u>Page</u>
16	Critical Temperature History of Leading Edge Panel-- Nominal Trajectory	56
17	Temperature History of Leading Edge Panel--Undershoot Trajectory	56
18	Temperature History of Crown Panel--Nominal Trajectory	57
19	Temperature History of Crown Panel--Undershoot Trajectory	58
20	Temperature History of Crown Panel--Overshoot Trajectory	58
21	Temperature History of Bottom Panel--Nominal Trajectory	59
22	Temperature History of Bottom Panel--Overshoot Trajectory	59
23	External Pressure and Thermal Load Conditions (Ablator Thickness Variation)	60
24	Leading Edge Panel Geometry	61
25	Crown Panel Geometry	62
26	Bottom Panel Geometry	63
27	Typical Panel Post Support and Sandwich Panel Cross Section	64
28	Leading Edge Airload Pressure Stresses	65
29	Crown Panel Airload Pressure Stresses	66
30	Bottom Panel Airload Pressure Stresses	67
31	Leading Edge Thermal Stresses	68
32	Crown Panel Airload Thermal Stresses	69

ILLUSTRATIONS (continued)

<u>Figure</u>	<u>Title</u>	<u>Page</u>
33	Bottom Panel Thermal Stresses	70
34	Leading Edge Airload Pressure Deflections	71
35	Crown Panel Airload Pressure Deflections	72
36	Bottom Panel Airload Pressure Deflections	73
37	Leading Edge Thermal Deflections	74
38	Crown Panel Thermal Deflections	75
39	Bottom Panel Thermal Deflections	76
40	Leading Edge Panel and Vehicle Interaction	77
41	Crown Panel and Vehicle Interaction	78
42	Crown Panel Drawing	79
43	Leading Edge Panel Drawing	80

RESEARCH STUDY TO PROVIDE CONCEPTS OF
PANEL ATTACHMENT MECHANISMS SUITABLE FOR
REFURBISHABLE PANEL APPLICATION

by

R. E. Rieckmann

SUMMARY

∠ A study has been made to select the best attachment mechanism concept for use in the refurbishable heat shield system. A number of concepts were developed and consequently evaluated to determine thermal and structural performance factors. With these factors, and considering the operations required for refurbishment, an evaluation was made to select the best attachment concept. The selected system was a NASA 602 ablator bonded to a phenolic/glass honeycomb substrate panel which was supported off the primary vehicle by phenolic/glass tapered cylindrical cups. ∷ The actual refurbishable panel tie is accomplished by the use of lock nuts which are put on aluminum stud fittings located on the primary vehicle shell. Insulation mats are installed between the vehicle and substrate panel.

∠ After selecting the attachment concept to be used, a detail structural analysis was made for three representative areas on an HL-10 manned lifting entry vehicle. ∷ The three areas were a leading edge section, a bottom section, and a crown section of the vehicle. ∠ Critical thermostructural conditions were determined and a digital analysis performed to determine aerodynamic and thermal substrate panel and standoff member stresses and deflections. ∷ In addition, the natural structural frequencies and modes were determined for each of the three panel analytical models.

This study evaluated a representative piece of hardware to define problem areas. All of the structural problem areas encountered can be minimized utilizing conventional engineering approaches. Hardware design would require a much more detailed definition of the manned entry vehicle system.

INTRODUCTION

The concept of a refurbishable heat shield provides a manned lifting entry vehicle structure with a multi-mission capability. Basically, this is accomplished by having a secondary structure which positions the heat shield and provides a hold down for the insulation. The refurbishable thermostructural panels for manned lifting entry vehicles must fulfill two basic functions. First, they

must provide a reliable structural path for thermal, aerodynamic, and inertia induced loads, and, secondly, they must provide a given amount of thermal protection for the vehicle. This thermostructural panel would be supported on the vehicle structure by local standoff members and encompass the required insulation. The ablator is bonded to the outer face of the structural substrate panel. Access to the thermostructural panel tie-down points is accomplished by local holes in the panel-ablator combination. Before flight, these access holes are filled with plugs of the ablator and sealed with an elastomeric silicone rubber compound.

Reference 1 studied a typical manned entry vehicle and mission in order to define the operating environment of the refurbishable heat shield panels. Using this environmental definition, Ref. 2 evaluated the thermal characteristics and substrate thermal-structural compatibility. This report summarizes the selection of the most reliable panel attachment system and studies in detail the structural integrity of the refurbishable heat shield. The following guide lines were used in this study.

- (1) Components of the attachment system will require minimum development and testing (present state of technology).
- (2) The ablator is a nonstructural element.
- (3) The vehicle structure may not be penetrated.
- (4) The fins and control surfaces not applicable to refurbishment concept for this study.
- (5) Panel standoff members are constant height for a given vehicle area.

This investigation was conducted under NASA-LRC Master Agreement Contract No. NAS 1-5253, Task Order No. 3, "Research Study to Provide Concepts of Panel Attachment Mechanisms Suitable for Refurbishable Panel Application." The study was performed by the Martin Company, Baltimore Division, under the direction of Dr. J. M. Hedgepeth, Program Manager. Mr. W. F. Barrett was Liaison Engineer for the program. Mr. R. E. Rieckmann was responsible for the overall technical direction of the program and was assisted by other members of the Martin Company engineering staff, including Mr. J. E. Mooney, Mr. A. Berwizky, and Mr. B. Taylor. Other contributors to the program include Mr. A. H. LaPorte, Mr. H. Hotchkiss, Mr. F. Levinsky, Mr. A. Stein, and Mr. B. Bata.

Mr. C. M. Pittman, of the Structures Research Division, Langley Research Center, Hampton, Virginia, was the technical representative for the project.

LIST OF SYMBOLS

E	Young's modulus
F	Allowable stress
f	Actual stress
G	Shear modulus
h	Height or depth
l	Length
q	Heating rate
R	Radius
T	Temperature
t	Thickness
x, y, z	Rectangular coordinates
ν	Poisson's ratio
θ	Angle
Subscripts	
A	Ablator
C	Core
L	Local
LS	Lower surface
RT	Room temperature
S	Shear
Stag	Stagnation
US	Upper surface
Fwd	Forward

SYSTEM COMPATIBILITY

In principle, the refurbishable heat shield concept will provide a manned lifting entry vehicle with a "throw-away" thermal protection system. Once used, it is discarded and replaced by a new set of panels. In order to recognize the practical hardware considerations and their influence on the thermo-structural panel design, a brief look will be taken at a typical vehicle.

The biggest single item which will influence the refurbishable panels is the vehicle access requirements. This will determine the panel size breakdown and consequently the number of panels required. A representative summary of potential vehicle access requirements and their influence on panel design is shown in Table 1.

Large access areas in a vehicle can be designed to rotate. However, due to the depth of the refurbishable panel system, it will be necessary to have a more complicated hinge and drive system, which, in turn, means a weight penalty. A representative hinged hatch is shown in Figure 1 along with a local access concept.

**TABLE 1. - POTENTIAL VEHICLE ACCESS REQUIREMENTS
AND THEIR INFLUENCE ON REFURBISHABLE PANELS**

Access requirement	Remarks
Small and moderate size access	
Auxiliary power supply Ground checkout system	Local refurbishable panel area would be removable
Antenna provision Indirect vision system	Specialized mechanical design of local panel area
Environmental control Ground communication	Local refurbishable panel area would be removable
Guidance requirements	Specialized design
Propellant resupply	Local removable plug
Large area access	
Gear doors Entrance hatches Recovery systems Parachute system Flotation system	Refurbishable panels would be sized to accommodate hatch contour

Another parameter which will influence the panel design is the basic construction of the vehicle. The thermostructural panels will be supported by local attachment points which, in turn, transfer concentrated loads into the vehicle. This must be taken at hard points in order to prevent any puncture danger to the pressure shell. This means that panel support spacing must be compatible with the vehicle stringer-frame spacing. If they are not compatible, a weight penalty will be imposed on the system. In the case of a full shell (monocoque, honeycomb, etc.) vehicle, the panel support spacing could be dictated by an allowable load and pad design criteria. Here again, a weight penalty is imposed.

In order to evaluate the efficiency of a refurbishable thermostructural panel system, a close look must be taken at the steps required to accomplish refurbishment. These are shown below, along with candidate methods to accomplish the steps:

- (1) Vehicle Available
- (2) Panel attachment location
 - (a) Color
 - (b) Surface discontinuity
 - (c) Master tool
- (3) Panel attachment access
 - (a) Drilling or cutting
 - (b) Burning
- (4) Disengage attachments
 - (a) Unscrewing
 - (b) Unlatching
- (5) Disengage boundary
 - (a) Cutting (sawing)
 - (b) Burning
 - (c) Chemical reaction
- (6) Remove panel

- (7) Inspection and replacement of components
- (8) Locate new panel
 - (a) Identification and manual placement
 - (b) Master tool
- (9) Engage new panel attachments
 - (a) Manual
 - (b) Power tools
- (10) Insert ablator and insulation plugs in attachment access holes
- (11) Seal panel boundary

As can be seen, there are eleven distinct steps required in order to accomplish a panel refurbishment. Therefore, it is desirable to keep the number of panels and panel attachment points to a minimum for a reasonable turnaround time. The vehicle-thermostructural panel system must then be simple, reliable, and lightweight in order not to penalize the overall vehicle weight and mission objectives.

PRELIMINARY ATTACHMENT MECHANISM CONCEPT SURVEY

Thermostructural Panel Environment and Design Criteria

Detailed studies of the aerodynamic and inertial loads, which the thermostructural panels would experience, were completed in Refs. 1 and 2. Basically, this work included surveys of the Manned Lifting Entry Vehicle pressure coefficients and time-dynamic pressure relationships in order to ascertain critical load conditions. The three re-entry trajectories considered were the overshoot, nominal and undershoot cases. A series of abort trajectories was also considered and two of these have an influence on the panel design. The preliminary design conditions and associated temperatures are summarized in Table 2 for the three representative vehicle panel locations. In addition to the items in the table, the trajectories were surveyed for the critical static load-thermal gradient conditions. Summaries of the critical thermal cases for the three representative panel areas may be found in the section of this report dealing with Detailed Study of Selected Concept.

The vibratory environment of the thermostructural panels is composed of several areas. For the boost phase, representative frequencies and noise levels are summarized in Ref. 1. Reference 2 considered the flutter aspect

TABLE 2. -SUMMARY PRELIMINARY OF CRITICAL PANEL DESIGN CONDITIONS

Vehicle panel location*	Overpressure		Temperature		Trajectory
	psi	kN/m ²	°R	°K	
Leading edge	8.5	58.5	585	325	Maximum load factor abort
	6.64	45.7	740	410	Undershoot
	2.60	17.9	1260	700	Nominal
Bottom	5.85	40.3	585	325	Maximum load factor abort
	4.64	32.0	740	410	Undershoot
	1.82	12.5	1260	700	Nominal
Crown	1.15	7.9	585	325	Maximum dynamic pressure abort
	0.44	3.03	740	410	Undershoot
	0.23	1.58	1260	700	Nominal
	-0.44	-3.03	1080	600	Overshoot

*See sketch on following page.

and found that it did not influence the panel design. Buffet of the vehicle during boost or re-entry is a difficult analytical problem; the program did not include funds to evaluate the severity of the problem.

The fatigue requirements for the refurbishable panels would be a function of thermal and structural cycling of the vehicle during a mission. Since no mission was defined for the representative vehicle, no specific criteria could be set. However, since the panels are basically a "one-shot" item, the fatigue influence on panel design should be minimal.

Structural margins of safety for the refurbishable panels will be based on the following: ultimate stress--1.5 factor of safety; yield stress--1.15 factor of safety, whichever is critical. No factors will be applied to the thermally induced stresses. When considering a thermal condition, the associated pressure load shall be added when critical.

A detailed evaluation of materials was completed in Ref. 2. This study will consider the materials from a panel attachment mechanism point of view. As per the results of Ref. 2, two candidate substrate materials show promise; these are phenolic/glass and steel. Both are capable of withstanding the load and thermal environment. Similarly, both exhibit potential to be utilized for the panel standoff members. The steel has a higher coefficient of thermal expansion at 1260° R (700° K) than the phenolic/glass. However, this difference could be alleviated by the use of flexible clips. A closer look at this problem will be taken in the subsection on Evaluation and Selection of Recommended

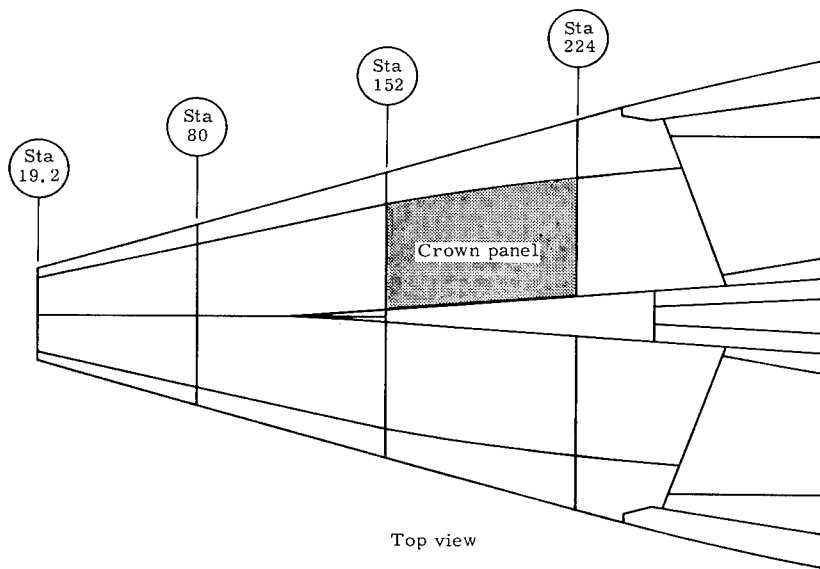
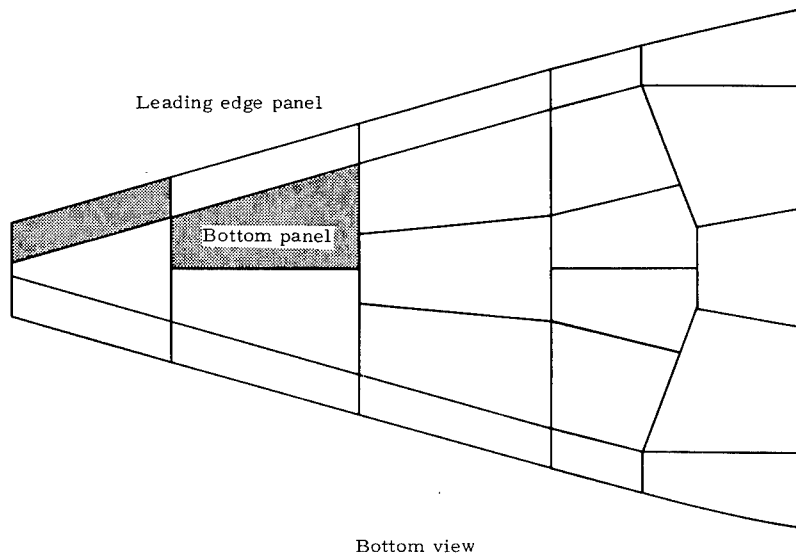

Concept. The fastening devices could be either steel, aluminum, or a phenolic/glass. The latter, however, would require development. Table 3 summarizes the pertinent advantages and disadvantages of the materials for use in the three structural components.

TABLE 3. - MATERIAL ADVANTAGES AND DISADVANTAGES FOR
 PANEL ATTACHMENT COMPONENTS

Component	Material	Advantages	Disadvantages
Panel	Steel	High strength	For minimum gage size re- straint of 22 in. (55.9 cm) for no splice. High coefficient of thermal expansion. High coefficient of thermal con- ductivity
	Phenolic/ glass	Lighter weight at minimum thickness. Low coefficient thermal expansion	4 ft (1.22 m) size restraint (no splices)
Standoff member	Steel	High strength	Thermal properties not as good as phenolic/glass
	Phenolic/ glass	Ease of manu- facture. Good thermal properties	Local stress concentration problem
Fastener	Steel	High strength	High coefficient of thermal conductivity
	Phenolic/ glass	Good thermal properties	Fasteners not developed
	Aluminum	Lightweight. Compatible with vehicle structure	Thermal characteristics not as good as phenolic/glass

Preliminary Thermal and Structural Studies

The attachment mechanism concept for the thermostructural panel must support load whether thermal or aerodynamically induced, and it must transfer a minimum of heat to the vehicle structure. In order to study the effect of heat short, a digital analysis was made using a representative standoff model and considering both steel and phenolic materials. Figure 2(a) indicates the temperature change both at the support and a point located midway between supports for a typical vehicle aluminum skin only. Figure 2(b) shows the effect of a variable heat sink located at the support point for a representative support spacing. A vehicle structure temperature increase above a specified design value will, for a fixed depth of insulation, adversely affect the thermal performance of the insulator. Figure 3 shows this effect. For example, if the structural temperature increased 38° R (21° K) due to a heat short above a design temperature of 610° R (339° K), it would require a 28% increase in insulation thickness and weight to maintain the original design temperature.

Figure 3(a) shows this with the indicated path. Figure 4 summarizes the volumetric and weight penalty to maintain the vehicle structure at 610° R (339° K). It becomes quite apparent that the steel standoff induces a significant weight and volume penalty as compared to the phenolic/glass.

A brief study was made of the ablator insert plug. A thermal analysis was made using a high density insert plug (silica phenolic material). The intent of the high density plug was to provide a noticeable surface discontinuity. However, with this material in the ablator, a very high temperature area results, which would destroy the ablator substrate bond and aggravate the heat short problem. As a result, the ablator plugs will be made of the same material as the ablator.

Structurally, there are three significant evaluation factors. These are thermal induced loads, static loads, and vehicle load interaction. Figures 5 and 6 consider the combination of thermally induced and static loads for a thermostructural panel. This particular case is a bottom panel design condition. Assuming a steel substrate panel at 1260° R (700° K) with a 2.73 psi (18.1 kN/m²) overpressure and a flexible steel support clip, a study was made to determine the allowable panel size and still be able to design the flexible clip. The results show that the maximum allowable steel panel size is somewhat smaller than 18 in. (45.6 cm). Similarly, this was done for a phenolic/glass panel with a phenolic/glass clip. This is shown in Figure 6. Here again, the allowable panel size is less than 18 in. (45.6 cm). Using the same design environment, an analysis was made considering rigid type panel support members. The results showed that the support members no longer were the critical design element, but rather the panel. This effect was due to the restraint against thermal deformation placed on the panel by the rigid supports. The resulting panel induced stresses indicated that the length limitation was not as severe as for flexible clips.

For standoff members, five potential types shown in the following sketch were studied. These were analyzed for a representative load condition to determine their structural requirements. The shapes were a cylindrical cup, a tapered

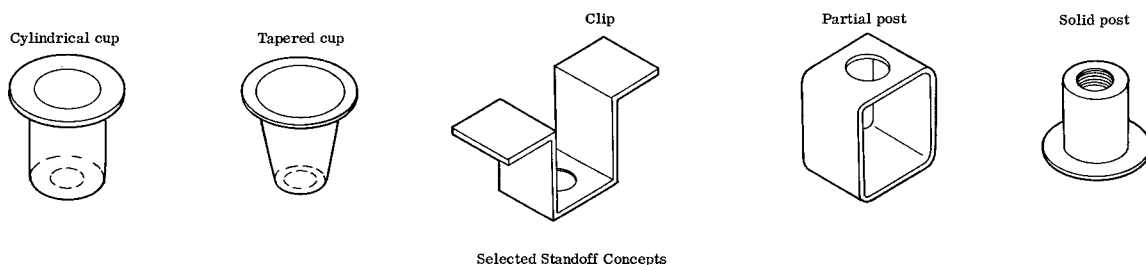

cylindrical cup, a flexible cup, a partial post, and a solid post. The flexible cup and partial post represented yielding supports while the others approached a non-yielding support. As was shown in the previous discussion, the flexible type clips would be impractical for consideration of moderate or large size panels. The solid post has several disadvantages; it is much heavier than the others and represents the closest thing to a fixed support, which implies having capability of transferring more moment load into the substrate panels. The ideal is a compromise between the above or the cylindrical and tapered cups. The tapered cup would approach a pinned condition on the vehicle surface and minimize vehicle structure-panel load interaction.

A preliminary study was made to ascertain the amount of vehicle load which could feed into the thermostructural panels. The simplified analytical model which was used consisted of a given width of panel assumed to be effective with the standoff member. Panel axial and rotational spring constants were used along with the standoff rotational and transverse spring constants. With a fixed angle maintained at the panel standoff intersection (fixed condition), the simultaneous equations were solved for the panel load. Table 4 summarizes the amount of load induced in the panels by the vehicle structure. As can be seen, the amount of load induced in the panel by the vehicle is comparatively small. The greatest alleviating factor is the panel bending stiffness. The basic substrate panel was chosen to be thin in order to keep the thermal gradients and weight to a minimum. This also keeps the volumetric penalty of the refurbishable heat shield to a minimum.

TABLE 4. - PANEL-VEHICLE LOAD INTERACTION

Number of standoff members	Percentage load	
	Phenolic/glass	Steel panel
2	0.00472	0.0252
3	0.0083	0.0426
4	0.020	0.072
Many	0.145	0.215

The remaining structural element which must be considered in some detail is the fastening device. Fasteners come in a variety of shapes and concepts. Generally, they are classified either structural or nonstructural and utilize one of three basic concepts: threaded, deformable, and removable. The following sketch shows the three basic fastening concepts and how they might be applied to a panel attachment system. A quantitative evaluation of the fastening concepts is shown in Table 5. This quick evaluation shows that the threaded fasteners will provide the greatest reliability. There are many unique approaches which could be taken if a new specialized design were made to fasten the panel to the vehicle. However, this was not the purpose of this study.

Fastening concept	Threaded	Deformable	Removable
Application	 <p>Stud-nut</p>	 <p>Rivet</p>	 <p>Turn-lock</p>
	 <p>Insert-bolt</p>	 <p>Clip-stud</p>	

TABLE 5. - EVALUATION OF FASTENING CONCEPTS

Concept	Load capability	Thermal performance	Vibration performance	Tolerance factor	Removability	Factor of merit	Remarks
Threaded	1.0	0.9	0.8	0.7	0.9	0.96	Can be located on vehicle surface for direct load input
Deformable	1.0	0.7	0.8	0.8	0.7	0.80	Creates more holes in panel. Rivets in tension for moment load
Removable	0.8	0.5	0.6	0.6	1.0	0.70	Locates mass in panel with resulting temperature penalty. Moment short coupling

Evaluation and Selection of Recommended Concept

Using the results of the previously mentioned studies and the potential concepts of standoff members and fasteners, preliminary panel attachment systems were developed. Table 6 summarizes the preliminary attachment system matrix. These are shown in Figure 7. Since the steel offers no significant structural advantages and provides a thermal problem, all the panel attachment components will be made of phenolic/glass material; this also includes the substrate panel (as recommended in Ref. 2). The fasteners will be made of aluminum and kept on the surface of the vehicle structure if possible. The following gives a brief description of the concept and its refurbishment procedure.

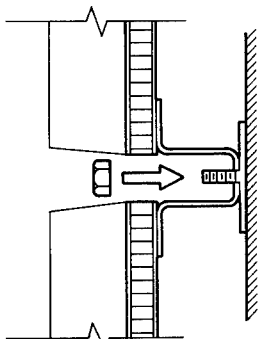
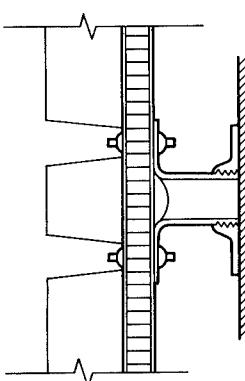
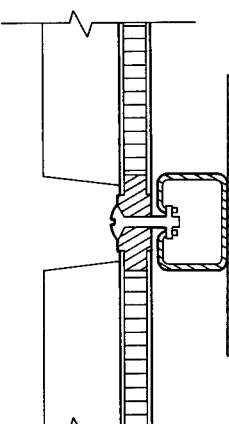
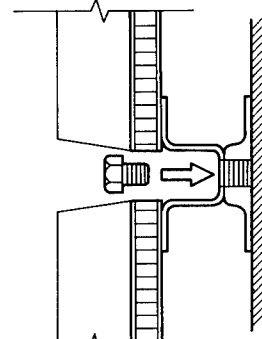
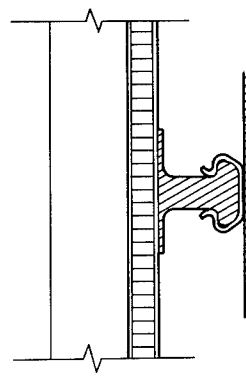
Concept 1. - A cylindrical or tapered cup is bonded to the substrate panel. Through the bottom an oversize hole is drilled to allow for support spacing tolerance. The tie-down stud fittings are made of aluminum and bonded to the vehicle structure; a master tool is utilized. The panel standoff member

TABLE 6. -SUMMARY OF THE PRELIMINARY ATTACHMENT SYSTEM MATRIX

Concept	Type of standoff	Type of fastener	Type of panel restraint
1	Cylindrical or tapered cup	Threaded	Rigid support
2	Cylindrical cup	Deformable	Rigid support
3	Partial post or clip	Removable	Flexible or unidirectionally rigid
4	Post	Deformable (mechanical)	Rigid support
5	Post	Deformable (mechanical)	Rigid support
6	Multiple cup	Threaded	Rigid support

(cup) and access hole through the panel and ablator are also located by use of this master tool. With all the components assembled, the refurbishable panel is ready for final installation. First the insulation is laid on the vehicle structure. Then the panel is placed with the vehicle studs protruding into the cups. A lock nut is installed for the final tie-down at each support point. Each cup is then filled with a plug of insulation followed by an ablator plug to close the heat shield discontinuity. Final sealing is then accomplished with an elastomeric silicone material.

Concept 2. - In this concept, a master tool is used to bond a tapped vehicle fitting to the structure. Into this, with the aid of a height gage, a flanged cylindrical standoff is inserted. By use of the same master tool, pilot holes are drilled into the panel and a small locator is bonded on. Again, the insulation is placed on the vehicle. The panels are then located and finally drilled for pull-rievet installed. After the rivet installation, the panel is tied down and again the ablator is handled as indicated in Concept 1.

Concept 3. - This concept employs a quick disconnect type attachment and a directionally flexible standoff member. The standoff is bonded to the vehicle structure by using a master tool for location. The same tool is used to place the quick disconnect insert into the substrate panel. The installation is similar to the Concept 1 procedure with the exception of locking the panel to the standoff by a quick disconnect.

Concepts 4 and 5. - Both of these concepts utilize the principle of an induced action lock. Concept 4 provides the lock by utilizing a torque tube, while Concept 5 locks by positioning. In both cases, again, the panel standoffs and the vehicle fittings are positioned by a master tool and bonded. Panel installation is self-explanatory. In both these concepts only the panel boundaries require sealing.

Concept 6. - This concept utilizes a multipoint support concept during over-pressure conditions. The substrate panel support is provided by an "egg-crate" type mat which is placed on the vehicle. The tie-down is provided at pre-determined node points as dictated by design conditions. In this case, the mat has one-half the insulation attached to it while the other half is a part of the substrate panel. Again, tie-down points would be located by master tools. The installation would involve placing the mat on the vehicle and attaching it via local stud fittings. After this, the panel is placed on top and tied to the mat through discrete bolts and inserts. Then, again, the ablator is handled as in Concept 1.

These represent the preliminary concepts and how they work. Each one, however, has its own advantages and disadvantages. Table 7 summarizes the major advantages and disadvantages of each concept.

For each of the concepts an evaluation was made considering the manufacturing aspects and deriving a total number of hours required. This effectively also indicates a relative cost trend. Table 8 summarizes this study. For the manufacturing study, a typical panel was defined as being 4 x 6 ft (1.22 x 1.83 m) with a 3-in. (7.61-cm) rise in the center and having 30 attachments. The hours shown are required for the manufacture and installation of the attachment system for one panel. This does not include the refurbishable panel and insulation.

The final panel concept selection will now be made using Table 9 which considers the important parameters associated with refurbishment and environment. It is quite apparent that Concept 1 provides the best attachment concept. Neglecting Concept 6, it is interesting to note that the factor of merit drops significantly for the other concepts, which indicates the argumentative ratings could be changed and still not alter the best concept choice. Concept 6 is an attractive approach; however, as pointed out, it has a built-in weight penalty because of the support mat and also, since the substrate panel is a minimum gage optimum, additional support points will not decrease the panel weight significantly. Therefore, Concept 1 is the recommended approach for the refurbishable panel attachment mechanism.

TABLE 7. - MAJOR PANEL ATTACHMENT CONCEPT
ADVANTAGES AND DISADVANTAGES

Concept	Advantages	Disadvantages
1	Can take dimensional tolerances easily Simple details	Substrate panel requires access hole Nut access may be marginal
2	Small substrate panel holes Height tolerance may be compensated for readily Hole filling attachment	Vehicle fitting tolerance very critical Danger of vehicle puncture during final drilling More mass in panel causing hot spot Panel removal more difficult Standoff must be replaced for each use
3	Quick panel removal	Big mass in panel creating bond line temperature problem Lock is not positive Location is very critical
4	Ablator not penetrated Quick panel removal	Many details Double curvature problem with tube Tolerance very critical Depends on moving parts
5	Quick removal Ablator not penetrated Parts are uniform making detail manufacturing easy	Tolerance very critical on panel and vehicle Reliability of positive engagement poor
6	Multipoint panel support Few pieces for final installation	Double curvature difficult to handle Weight

**TABLE 8. - SUMMARY OF HOURS REQUIRED TO
MAKE AND INSTALL REFURBISHABLE PANEL CONCEPTS**

Concept	Manufacturing			Planning	Tooling design	Labor	Total hours
	Details	Assembly	Installation				
1	42	6.2	4.5	75	36	174	337.7
2	37.5	22.0	14.0	80	134	470	757.5
3	18	31.2	2.75	110	80	294	535.95
4	74.1	21.75	2.95	115	162	554	929.8
5	23.1	8.65	3.9	75	94	346	550.65
6	22.5	10.1	4.9	95	48	308	488.5

TABLE 9. - EVALUATION OF PANEL ATTACHMENT CONCEPTS

Concept	Reliability	Access to disengage	Vehicle damage factor	Tolerance factor	Panel removal	Mfg and tooling	Load capability	Vibration capability	Thermal capability	Factor of merit	Remarks
1	1.0	0.8	1.0	1.0	0.8	1.0	0.90	0.70	1.0	0.90	Simple design
2	0.8	0.6	0.6	0.6	0.8	0.20	0.80	0.60	0.9	0.66	Installation trouble
3	0.6	0.8	1.0	0.5	0.9	0.6	0.60	0.50	0.7	0.69	Heat loosens
4	0.4	1.0	0.7	0.2	1.0	0	0.70	0.40	0.8	0.58	Too complex
5	0.2	1.0	0.8	0.1	0.9	0.4	0.50	0.30	0.8	0.56	Alignment problem
6	0.8	0.8	1.0	0.7	0.8	0.8	1.00	0.90	0.90	0.86	Weight

Panel Design and Sensitivity Studies

To do detail analysis of the refurbishable panels, a design tool must be handy in order to evaluate the required support spacing for a given panel design condition. Figures 8 through 13 provide this data. The design curves consider two ablators, NASA 602 and a low density nylon phenolic, and four temperature conditions. This allows a check of design environment to determine the critical condition. Considering a room temperature design condition with a panel having 1.0 in. (2.54 cm) of NASA 602 ablator and a pressure of 4 psi (27.5 kN/m²), what is the required spacing for minimum weight? By referring to Figure 8 and finding the depth of ablator, a vertical projection to the minimum gage may be made, with the intersection of this vertical line with the minimum weight thickness line, a horizontal projection to the 4 psi (27.5 kN/m²) line will determine the required support spacing of 15 in. (38.1 cm). Table 10 shows a typical result of applying

**TABLE 10. -REQUIRED SUPPORT SPACING FOR
MANNED ENTRY VEHICLE REFURBISHABLE PANELS**

Panel area	Overpressure		Temperature		Maximum ablator depth		Required support spacing	
	psi	$\frac{kN}{m^2}$	°R	°K	in.	cm	in.	cm
NASA 602 ablator								
Leading edge	12.75	87.6	585	325	1.4	3.56	7.3	18.5
	9.95	68.5	740	411	1.4	3.56	8.7	22.1
	3.90	26.8	1260	700	1.4	3.56	9.5	24.1
Bottom	8.73	60.0	585	325	1.07	2.72	9.5	24.1
	6.95	47.8	740	411	1.07	2.72	11.5	29.2
	2.73	18.8	1260	700	1.07	2.72	12.5	31.8
Crown	1.73	11.9	585	325	0.36	0.92	26.5	80
	0.66	4.6	740	411	0.36	0.92	40	147.0
	-0.66	-4.6	1080	600	0.36	0.92	34.0	86.4
	0.35	2.4	1260	700	0.36	0.92	32.0	81.3
Low density nylon phenolic ablator								
Leading edge	12.75	87.6	585	325	1.47	3.74	3.8	9.65
	9.95	68.5	740	411	1.47	3.74	6.5	16.5
	3.90	26.8	1260	700	1.47	3.74	9.5	24.1
Bottom	8.73	60.0	585	325	0.98	2.49	5.6	14.2
	6.95	47.8	740	411	0.98	2.49	7.8	19.8
	2.73	18.8	1260	700	0.98	2.49	12.5	31.8
Crown	1.73	11.9	585	325	0.34	0.86	18.5	47.0
	0.66	4.6	740	411	0.34	0.86	41.0	122.0
	-0.66	-4.6	1080	600	0.34	0.86	34.0	86.4
	0.35	2.4	1260	700	0.34	0.86	32.0	81.3

the design conditions to a manned entry vehicle to determine the critical support spacing for the three representative panels. The support spacing defined is always the short dimension of a panel with an aspect ratio of 1.5.

Table 10 shows that for the representative vehicle, the room temperature condition is the critical design case. Therefore, knowing the pressure and temperature conditions on any vehicle will define a critical support spacing and condition.

Once a support spacing is defined, it is imperative to have this compatible with the vehicle structure hard point spacing. If the vehicle spacing is greater, a weight penalty will result in the substrate panel. This is shown in Figure 14 for both a NASA 602 and a low density nylon phenolic ablator. The weight penalty for the substrate panel is much more severe for the low density nylon phenolic. For example, if the vehicle hard point spacing in the leading edge area is 2 in. (5.08 cm) greater than required by minimum weight panel support spacing, a weight increase of 25% in the substrate panel is incurred. However, the substrate represents only a part of the system weight. Considering both substrate panel and ablator weight would represent a better picture. This is shown on the lower part of Figure 14.

This figure shows that the low density nylon phenolic panel weight will be less than the NASA 602 panel for a vehicle hard point spacing of 6.4 in. (16.25 cm) or less in the leading edge area and 10.65 in. (27.1 cm) or less in the bottom panel area. Although the low density nylon phenolic has more desirable thermal protection characteristics, other factors must be considered. As shown in ref. 2, the reliability and manufacturing restraints of the low density nylon phenolic become significant evaluation parameters.

As a result of the above mentioned items, the detail analysis of a refurbishable panel will be based on a NASA 602 ablator and a panel attachment concept as shown in Figure 15.

DETAIL STUDY OF SELECTED REFURBISHMENT CONCEPT

Structural Design Conditions

The detail structural design of a given thermostructural panel will depend on the relationship between temperature and pressure for a given trajectory. In order to evaluate the pressure-temperature matrix and select critical conditions, the temperature-histories were determined for the three representative panels using refs. 4 and 5. Basically, this involved breaking down the panel and attachment system into convenient elements and applying finite difference methods to the solution of the heat transfer problem. By using the ablator (NASA 602) thickness requirements for each panel as defined in ref. 2, and the three re-entry trajectories, critical design condition cases were selected

for each panel. The critical temperature-histories for the leading edge, crown, and bottom panels are shown in Figures 16-17, 18-19, and 20-22, respectively. For each panel and trajectory, points were chosen which represented maximum longitudinal panel temperature gradients, maximum transverse panel gradients, maximum temperature, and maximum pressure-temperature conditions. From the known time in a trajectory, a corresponding pressure load was determined using data from ref. 2. Evaluation of all the re-entry trajectories for the three representative panel areas showed that the overshoot trajectory was not critical for the bottom panel. These conditions were then evaluated and critical analytical cases chosen.

Ascent and abort trajectories were also considered; however, the panel temperatures were not critical for design consideration. The orbital cold soak condition represented a maximum negative gradient for the three panels and was included as an analytical case.

Table 11 summarizes the thermal load conditions which were considered for the three panels. Panel temperature and corresponding pressures for these considered analytical conditions can be found in Figure 23.

TABLE 11. -SUMMARY OF CONSIDERED PANEL THERMAL LOAD CONDITIONS

Panel	Trajectory	Time, sec	Remarks	Analytical designation
Leading edge	Nominal	1400	Maximum longitudinal and transverse panel temperature gradient	L-2
	Nominal	1800	Maximum panel temperature	L-3
	Undershoot	130	Maximum pressure-temperature	L-4
Crown	Nominal	1650	Maximum panel temperature	C-2
	Undershoot	300	Maximum transverse temperature gradient	C-3
	Overshoot	2550	Maximum panel temperature-pressure condition	C-4
Bottom	Overshoot	1500	Maximum panel transverse temperature gradient	B-2
	Nominal	2000	Maximum panel temperature	B-3

Structural Analysis

A comprehensive elastic-load-distribution analysis was made on three basic panel geometries for the chosen preliminary optimum refurbishable heat shield design. Internal panel loads, stresses and overall deflections resulting from external pressure and thermal loads were investigated. In addition, panel and vehicle interaction, and fundamental frequencies and mode shapes were determined. Although the three panel configurations are based on the HL-10 vehicle configuration, they are "typical." Thus, the resulting analysis provides a considerable amount of both quantitative and qualitative information about the internal loads, deflections, stresses, panel-vehicle interaction, and natural frequencies for the three representative panels.

These panels were of such complexity in geometric form and structural makeup that accurate classical methods of analysis became nearly impossible. For this reason, experience dictated the use of a superior approach utilizing "matrix structural methods" based on discrete element idealization of the structure to be analyzed. Here, the elements were assembled to form the complete analytical model of the structure by joining all the elements at their respective juncture points, applying in this process the requirements of juncture point equilibrium and compatibility. The technique used for this analysis is based upon the matrix "force" method and was developed by S. Kaufman and D. Hall (ref. 3).

Model description. - The three basic typical panel geometries consisted of:

- (1) Leading edge panel
- (2) Crown panel
- (3) Bottom panel

The idealized grid point networks defining these panels are shown in Figures 24, 25 and 26. Optimum panel materials, thickness and overall sizes were investigated and determined in ref. 2. The support concept is as determined in the subsection Evaluation and Selection of Recommended Concept of this report.

The substrate structure is a phenolic/glass sandwich panel composed of thin phenolic/glass structural skins and a heat resistant phenolic honeycomb core (Figure 27a). The strong core direction was always oriented in the longitudinal direction of the panel. The skins are represented by tension and shear panel elements which are coupled with each other to incorporate the Poisson effects that exist in a biaxial stress field. The honeycomb core is represented by shear panels and tension post elements which, together with the skins, form a "box section" network.

A typical phenolic/glass standoff as used for this analysis is shown in Figure 27b. These standoffs were idealized by posts using tension and

bending elements. In all cases, longitudinal in-line posts are connected by tie rods which simulate the longitudinal flexibility of the support structure. Infinitely rigid support reactions are provided in the other directions at each support post base (Figures 24, 25 and 26).

The leading edge panel as shown in Figure 24 with three rows of five in-line supports was also considered with three rows of three in-line supports. This latter geometry demonstrated extremely high stresses under the critical load conditions and as a result was not further investigated. Symmetry was assumed in one direction for the leading edge (Figure 24). Later results indicated that the structure was for all practical purposes doubly symmetric. As a result, later plots portray only one quarter of the structure.

Failure criteria. - From the standpoint of structural analysis, failure of the refurbishable heat shield panel can occur from any one or all of the following:

- (1) Stresses
- (2) Deflections
- (3) Dynamics
- (4) Stability

Appropriate consideration was given to each of these criteria in this comprehensive analysis.

The temperature dependent allowable materials stresses used in this analysis can be found in ref. 2 and in Figures 23 and 27. Since the substrate panel skins have access holes (Figure 15), the resulting skin stresses will increase locally around the holes. The stress concentration factor ranges between 2.5 and 3.5, depending on the biaxial stress ratio (ref. 6).

Although the ablator imposes no limitations on the growth of the support panel, it does impose a constraint on the allowable bending strain which occurs at room temperature. Converting this criterion from allowable strain to stress yields the following relation for the NASA 602 ablator on the phenolic/glass sandwich panel, having a depth of 0.375 in. (0.955 cm), at room temperature.

$$\left| f_{US} - f_{LS} \right| < \frac{0.135}{5.33 h_A + 1} E_{\text{skin}}$$

where the ablator depth h_A is in inches. For the panels considered herein, this allowable stress constraint is given in Figure 23.

Several other deflection limitations must be met. To illustrate, longitudinal and transverse deflections should not be so large as to cause contact stresses

with adjacent panels, normal deflections must not be so large as to violate surface smoothness criteria which are established by the flight dynamics group, and finally, the panels are required to withstand the deflections imparted by the vehicle support structure. Since the panels in this investigation are "study" panels, no deflection requirements of this nature were imposed. However, close attention and consideration was given to the magnitudes of the final deflections.

Several dynamic aspects of the panels are considered. Preliminary investigations of flutter, in ref. 2, indicated that it was not a controlling panel design factor. As pointed out in the section on Thermostructural Panel Environment and Design Criteria Materials Survey, buffeting is beyond the scope of this report. Natural frequencies and mode shapes may be controlling design factors and were thus determined.

Although general instability is not a problem, local sandwich skin and core buckling must be considered. Basically, three types of such failure modes can occur. These consist of intracell buckling, face sheet wrinkling, and shear crimping. Using the methods of analysis as shown in refs. 7 and 8, local stability was evaluated for critical panel areas and found to be no problem.

Stresses. - Skin and support post stresses resulting from normal surface pressure loads at room temperature are shown in Figures 27, 28, and 29 for the three typical panels. For such a loading condition, the stresses always peak out at the support points. Since the support point panel holes are 1 in. in diameter, stress values at the supports should be taken 1/2-in. from the support axis. Table 12 summarizes these maximum stresses at the support points and corresponding margins of safety.

TABLE 12.-MAXIMUM SKIN STRESSES AND MARGINS OF SAFETY
AT SUPPORT POINTS ($f = 60$ ksi, 413 kN/m²)

Panel	External pressure	Nominal stresses at support holes		Concentration factor	Maximum stress		Margin of safety
		ksi	MN/m ²		ksi	MN/m ²	
Leading edge Condition L-1 (Ref. Fig. 23)	12.75 psi (87.9 kN/m ²)	$f_1 = +22$	151.5	2.25	49.5	341.0	+0.21
		$f_2 = +15$	103.2	2.15	32.2	222.0	+0.86
Crown Condition C-1 (Ref. Fig. 23)	1.73 psi (11.8 kN/m ²)	$f_1 = +8.5$	58.5	2.45	+20.8	+143.1	+1.88
		$f_2 = +4.5$	31.0	2.45	+11.0	+75.7	+4.45
Bottom Condition B-1 (Ref. Fig. 23)	8.73 psi (60.1 kN/m ²)	$f_1 = +8.5$	58.5	2.4	20.4	140.5	+1.94
		$f_2 = +4.8$	33.0	2.4	11.5	79.1	+4.22

Table 13 summarizes the maximum core shear stresses and margins of safety for the critical airload condition.

TABLE 13. -MAXIMUM CORE SHEAR STRESSES AND MARGINS OF SAFETY

(Strong Direction $f_c = 0.505$ ksi, 3.48 kN/m²
Weak Direction $f_c = 0.275$ ksi, 1.89 kN/m²)

Panel	Pressure load	Core strong direction, f_c	Margin of safety	Core weak direction, f_c	Margin of safety
Leading edge Condition L-1 (Ref. Fig. 23)	12.75 psi (87.85 kN/m ²)	0.161 ksi (1.11 MN/m ²)	+2.14	0.318 ksi (2.19 MN/m ²)	-0.135 (+0.52)*
Crown Condition C-1 (Ref. Fig. 23)	1.73 psi (11.91 kN/m ²)	0.043 ksi (0.296 MN/m ²)	+10.7	0.0482 ksi (0.332 MN/m ²)	+4.71
Bottom Condition B-1 (Ref. Fig. 23)	8.73 psi (60.2 kN/m ²)	0.0972 ksi (0.67 MN/m ²)	+4.2	0.0514 ksi (0.355 MN/m ²)	+4.36

*Using a denser core, the percentage weight increase for the panel would be 1.4%.

These figures indicate that the leading edge core is critical in the weak direction. Actually this shear stress occurred at a support point. The problem can be alleviated by densifying the core in the weak direction or increasing the core density. This would not create an excessive weight penalty as indicated by the note under the table.

Maximum stresses induced in the vehicle structure for these pressure loads were 386 psi (2.660 MN/m²), 181 psi (1.249 MN/m²) and 157 psi (1.080 MN/m²) for the leading edge, crown and bottom panels, respectively. It is interesting to note that they are not significant.

As previously mentioned, the ablator maximum strain allowable for the panels at room temperature required that the difference in skin stresses in the upper and lower surfaces be within certain maximums. This is summarized in Table 14. As would be expected, the leading edge which has the highest pressure stresses and yet the lowest allowable stress differential due to the thick ablator is critical. This problem can be corrected by providing pads at the supports to decrease the panel internal load strain.

TABLE 14. - SUMMARY OF CRITICAL SUBSTRATE DIFFERENTIAL STRESSES AND MARGINS

Panel	Maximum stress differential	Maximum allowable stress differential	Margin of safety
Leading edge Condition L-1	95 ksi (655 MN/m ²)	61 ksi (421 MN/m ²)	-0.358 (+0.26)*
Crown Condition C-1	15 ksi (103.5 MN/m ²)	120 ksi (827.0 MN/m ²)	+7.0
Bottom Condition B-1	16 ksi (110.6 MN/m ²)	82 ksi (565 MN/m ²)	+4.12

*Addition of a doubler around the hole on the upper and lower surface; resulting weight increase would be 1%

Examination of the pressure stress fields indicates that in general the loads are taken predominantly by bending and shear for flat surfaces. Axial loads become prominent when curvature is present (arch effect). This phenomenon is shown very clearly in the leading edge panel where the pressure loads in the flat longitudinal direction are, for all practical purposes, pure bending and shear, whereas in the circumferential (or transverse) direction the surface skins contain axial loads. These axial loads, in turn, decrease the shear loads in the core tangential direction. Thus, from these trends, the following conclusions can be drawn about the panel from pressure loads.

- (1) Flat panels take pressure loads predominantly in bending and shear.
- (2) Curved panels take the pressure loads in bending, shear, and tension in the direction of curvature. The core stresses are decreasing due to this effect.

Further, verification of the strengthening or arch effect of the curvature is demonstrated by the dynamic response of the leading edge. This was shown by the normalized modal deflection results of the digital analysis. The first fundamental frequency of the leading edge was in the longitudinal direction, whereas, in the crown and bottom panels, the first fundamental frequency was a normal mode.

Skin and support post stresses resulting from the most critical thermal condition are shown in Figures 31, 32 and 33. As in the case of a pressure load, the thermal stresses are highest at the support points and are shown in Table 15 along with resulting margins of safety.

TABLE 15. - MAXIMUM SKIN STRESSES AND MARGINS OF SAFETY AT SUPPORT POINTS

Panel	Thermal load condition (Figure 23)	Nominal stress at support holes	Margin of safety without concentration factor	Concentration factor	Maximum stress	Margin of safety
Leading edge	L-2	$f_1 = +12.0$ ksi (82.7 MN/m ²)	+0.42	3.16	37.9 ksi (261 MN/m ²)	-0.55 (+0.12)*
		$f_2 = -3.0$ ksi (-20.6 MN/m ²)	+4.67	3.25	-9.75 ksi (-67.1 MN/m ²)	+0.74
Crown	C-4	$f_1 = 8.5$ ksi (58.5 MN/m ²)	+1.0	3.15	26.8 ksi (184.5 MN/m ²)	-0.365 (+0.59)*
		$f_2 = -2.0$ ksi (-13.78 MN/m ²)	+7.5	3.45	-6.9 ksi (47.5 MN/m ²)	+1.47
Bottom	B-3	$f_1 = 14.2$ ksi (117 MN/m ²)	+0.20	3.0	51.0 ksi (351 MN/m ²)	-0.60 (+0.00)*
		$f_2 = -2$ ksi (-13.78 MN/m ²)	+7.5	3.1	6.2 ksi (42.6 MN/m ²)	+1.74

*Addition of a doubler around the hole on the upper and lower surface resulting weight increase would be 1%

The above figures indicate that the panels have exceeded their design limits. In the case of the bottom panel, the large pressure loads dictated the use of many supports--these, in turn, increased the thermal stresses. By far the largest single item contributing to these stresses is the stress concentration factor. The use of a bonded structural doubler around the support hole would greatly alleviate the stresses and thus enhance the design as indicated in the tables. Since the pressure condition is not as marginal for the crown and bottom panels, further thermal stress reduction might be provided by increasing the spacing of the supports.

Investigation of the thermal core shear stresses leads to the following set of maximum values summarized along with margins of safety in Table 16.

TABLE 16. - MAXIMUM CORE SHEAR STRESSES DUE TO THERMAL LOADS

(Strong Direction $f_c \approx 0.143$ ksi, 0.985 MN/m²
Weak Direction $f_c \approx 0.075$ ksi, 0.517 MN/m²)

Panel	Thermal load (Figure 22)	Core strong direction, f_c		Margin of safety	Core weak direction, f_c		Margin of safety
		ksi	MN/m ²		ksi	MN/m ²	
Leading edge	L-2	0.176	1.21	-0.286 (+0.88)*	0.0362	0.249	+1.07
Crown	C-4	0.0624	0.43	+1.30	0.0419	0.288	+0.79
Bottom	B-3	0.0798	0.549	+0.79	0.1608	1.105	-0.533 (+0.130)*

*Using denser core the percentage weight increase for the panel would be 1.4%

The approximate allowable core stress values computed above were proportioned since insufficient data was available for the exact allowables at elevated temperatures. Further investigation must be made in this area. As can be seen from the above summarized data of core shearing stress, the design limits have been exceeded in several cases. This situation can be alleviated by the following changes:

- (1) Densify the core locally around the support
- (2) Orient the strong core direction at right angles to the present direction
- (3) Densify the entire core.

Maximum stresses induced in the vehicle structure for these thermal conditions were 1064 psi (7320 kN/m^2), 678 psi (4660 kN/m^2) and 1020 psi (7010 MN/m^2) for the leading edge, crown and bottom panels, respectively. Although these stresses are much higher than the pressure induced stresses, it appears that they will not affect the vehicle design significantly.

Examination of the thermal stress fields indicates that for flat surfaces, the loads are predominantly axial at mid-span and are combined axial bending and shear at the supports due to support "kick" loads. In the direction of curvature for curved panels, the loads at mid-span and at the supports are combined shear, bending, and axial (similar to a column with initial eccentricity). Thus, in a sense, the converse of the condition for pressure stresses exists.

Although the detailed computer analysis generates major load paths and general magnitudes, additional analysis and design considerations should be given to the support cup-refurbishable panel interface. Consideration of the outer diameter of the support cup, the panel thickness and the cup lip size leads to an area into which the support post load must be transferred through shear and compression. From this can be made rough estimates of the localized loads. Design considerations such as these indicate that generally one or all of the following should be done:

- (1) The core should be densified in the immediate area around the support ($R = 2.5 \text{ in.}, 6.35 \text{ cm}$) to provide adequate shear and compressive capabilities, or the basic core density should be increased.
- (2) An elliptical or rectangular tapered support cup could be utilized instead of a circular cup. The cup long and short dimensions would be proportioned with the weak and strong core shear strengths. With the long cup dimension normal to the weak core direction, localized failure would be minimized in the core.
- (3) Vertical glass/phenolic stiffener plates or shear spars could be provided radially at the support area.

Investigation of all localized buckling phenomena associated with sandwich panels indicated that no stability problems existed.

Deflections. - As previously mentioned, no specific deflection failure criteria were applicable to these "study" panels. Figures 33, 34 and 35 contain graphs of deflections due to pressure loads. The following maximum deflections were obtained for pressure loads are summarized in Table 17.

TABLE 17. - MAXIMUM DEFLECTIONS DUE TO PRESSURE LOADS

Panel	Load case (Figure 22)	Maximum normal deflection	Maximum edge longitudinal deflection	Maximum edge transverse deflection
Leading edge	L-1	0.085 in. (0.216 cm)	Growth 0.0068 in. (0.0173 cm) Shrinkage 0.0061 in. (0.0155 cm)	Growth (none) Shrinkage 0.045 in. (0.114 cm)
Crown	C-1	0.11 in. (0.28 cm)	Growth 0.004 in. (0.0101 cm) Shrinkage 0.003 in. (0.00762 cm)	Growth 0.028 in. (0.071 cm) Shrinkage 0.08 in. (0.203 cm)
Bottom	B-1	0.108 in. (0.275 cm)	Growth (none) Shrinkage 0.01 in. (0.0254 cm)	Growth 0.04 in. (0.101 cm) Shrinkage (none)

Similarly, Figures 37, 38 and 39 contain graphs of deflections due to thermal loads. The maximum deflections for the thermal loads are summarized in Table 18.

TABLE 18. - MAXIMUM DEFLECTIONS DUE TO THERMAL LOADS

Panel	Load case (Figure 22)	Maximum normal deflection	Maximum edge longitudinal deflection	Maximum edge transverse deflection
Leading edge	L-2	0.061 in. (0.155 cm)	Growth 0.055 in. (0.14 cm) Shrinkage (none)	Growth 0.033 in. (0.084 cm) Shrinkage (none)
Crown	C-4	0.18 in. (0.458 cm)	Growth 0.084 in. (0.213 cm) Shrinkage 0.08 in. (0.203 cm)	Growth 0.083 in. (0.21 cm) Shrinkage (none)
Bottom	B-3	0.125 in. (0.318 cm)	Growth 0.06 in. (0.152 cm) Shrinkage (none)	Growth 0.035 in. (0.089 cm) Shrinkage (none)

Deflection results indicate that (1) supports should be placed as near as possible to panel corners to minimize the maximum thermal normal deflections which occur at the corners, (2) panels should contain a minimum of 0.1 in. (0.254 cm) of clearance between panels in the longitudinal and transverse direction to avoid contact stresses.

Panel-Vehicle Interaction. - An evaluation was made for the three representative panels to determine the resulting panel-vehicle structure load interaction. The results showed that the interaction is small and will not significantly alter the panel design. Two representative panel interaction load summaries are shown in Figures 40 and 41. These represent the two extremes in panel configuration. The bottom panel interaction loads were similar, and since it merely represented a configuration between the two shown, it was not included. Although some of the load sheared out into other support rows, the major loads were received by the skin structure immediately above the loaded lower support row. Again, as can be seen from these figures, the magnitudes of the loads received by the refurbishable panel skins are quite small. This was desired. Designs of panels for actual vehicles should include these loads.

Normal deflection can occur in the support structure and also cause interaction with the refurbishable panel. One of the original "ground rules" for using this concept was that the panel supports be placed over hard spots on the structure. Consideration of the loads resulting from a normal deflection of 0.1 in. (0.254 cm) at one of the support points at a time indicates that the resulting maximum loads for all three panels are in the range of 1 kip (6.89 MN). This does not appear to present an adverse condition. If these hard spots are subject to significant normal deflections, further investigation should be provided in this area. Designs of panels for actual vehicles should include loads resulting from such deformations.

Longitudinal loads imparted to the support vehicle structure were discussed in the subsection on Stresses. As pointed out, they were not significant enough to effect the design of the support structure.

Natural Frequencies. - Although no specific requirements or failure criteria with respect to natural frequencies were set for these panels, it was presumed that the panels would not be frequency critical if their natural frequencies were high. Table 19 contains the lowest 10 frequencies for each of the three panels. As can be seen by these figures, the crown panel has the lowest fundamental frequency of 72.27 cps, whereas the other panels demonstrated frequencies over twice as large. These results indicate that in all probability the leading edge and bottom panel will not be frequency critical. However, dynamic problems may exist with the crown panel, which has few supports due to the low pressure loads. If dynamic problems did exist, corrective measures could be provided by increasing the number of supports.

Remarks Regarding the Analysis. - Valuable information and guidelines about the structural response characteristics of the refurbishable heat shield panels

TABLE 19. - FUNDAMENTAL NATURAL FREQUENCIES OF PANELS

Leading Edge Panel		
Mode	Natural frequency (cps)	Dominant mode shape
1	187.76	Longitudinal
2	244.02	Radial
3	254.89	↓
4	281.03	
5	283.09	
6	290.30	
7	300.30	
8	334.49	
9	339.09	
10	342.37	
Crown Panel		
1	72.27	Normal
2	91.44	↓
3	94.51	
4	95.90	
5	102.24	
6	104.01	
7	105.21	
8	107.00	
9	120.57	
10	126.34	
Bottom Panel		
1	196.15	Normal
2	209.95	↓
3	243.1	
4	247.5	
5	248.8	
6	262.9	
7	265.3	
8	269.83	
9	274.46	
10	281.09	

were established. To illustrate, based on preliminary design information provided in the first two sections of this report and in ref. 2, it was hoped that these panels and their support systems were chosen to be an optimum--which meant that they were at the borderline of failure for the given load conditions. Although negative margins of safety were exhibited in the final detailed analysis in many instances, the panels were in the correct realm of design. Where each of these negative margins occurred, corrective measures were easily applicable, as pointed out. Based on the results of this analysis, it is felt that future detailed computer analysis should utilize a very fine grid network at the supports and a very fine grid network to represent the supports. In this manner, highly localized effects could be determined. An important aspect of detail analysis deals with the ability to size a structure for a design condition through the use of design tools. Incorporated into this report are design charts which enable a designer to "get into the ball park" structurally. These curves are based on a flat rectangular pattern of support points with an average aspect ratio of 1.5. (This covers the majority of design geometry considered.) The detail panel analysis justified the use of these design tools. The following table summarizes the predicted and computed stresses. Generally it will be noticed that the predicted and computed stresses are very close. The bottom panel by virtue of its geometry and having a significantly different aspect ratio did not agree as well as the others. An aspect ratio correction was incorporated in the predicted stress, but no correction can be made to reflect geometry. Table 20 shows that the design chart use is justified within the realm of the ground rules used.

TABLE 20. - COMPARISON OF PREDICTED AND COMPUTED PANEL STRESSES

Panel	Average spacing (short dimension)		Predicted stress (design charts)		Computed stress (digital analysis)		% Variation
	in.	cm	ksi	MN/m ²	ksi	MN/m ²	
Leading edge	8.36	21.2	48	330	49.5	344	2.5
Crown	16.0	40.6	21.2	146	20.8	143	1.9
Bottom	11.5	29.2	28.4	196	20.4	140	39.3

Sensitivity of Refurbishable Panel System

This section considers the weight sensitivity of the refurbishable panels with environmental and hardware variations. The two most significant environment parameters are pressure and temperature. Both directly influence structural design. An increase in pressure for a fixed support spacing will increase the strength requirements locally at the support points. This affected area where a doubler would be placed is about 10% of the supported panel area. Doubling

the thickness in the support area would change the total unit system weight about 1%. Therefore, the substrate panel weight is insensitive to normally expected pressure changes. If the case of water impact is to be considered, the design philosophy will change for the panels. Water landing will create extremely high pressure fields for small finite time increments. Two analytical areas would have to be explored. These are a structural response to a shock type loading function and a time study of the panel failure mode. For this case, the panel failure mode should be of such a nature that the danger of puncturing the vehicle is minimal or, ideally speaking, the panel should fail and move in a pure translational path (no rotation). For the panels which were analyzed, the facts that they are constructed of nonmetallic materials, are hot from the re-entry phase, and are critical structurally at the support points, indicated that they should fail at supports by a honeycomb core shear failure and settle down on the vehicle structure with minimum chance of rotating and creating a puncture danger.

Anticipated temperature changes would normally be considered during the panel design phase. Factors of safety, as defined by a statistical approach to probability of the occurrence of multivariables defining panel temperature, would be incorporated into the structural design. These temperature changes would be a function not only of environmental variations but also changes in ablator and panel material thermal characteristics. The panel weight is, therefore, not weight sensitive to temperature change.

Vehicle aerodynamic shape influences the design of the refurbishable panels. However, this effect of curvature is of a beneficial nature structurally. The section on Detailed Study of Selected Concept discusses this in detail. The penalty is predominantly in the system cost due to the curvature involved in manufacturing. Generally speaking, decreasing the radius of curvature by a third, will increase the cost 40% for the attachment system. Another very significant panel cost parameter is the height variation of the standoff cups. This study considered that, for a representative panel area, the standoff members were of constant height. This implies that the outside skin line is not being maintained by the difference in ablator thickness between the forward and aft ends. If the vehicle mold line were to be held, the standoffs would vary in height for a panel and create a need for many more tools. In addition, if the ablator thickness varied in both longitudinal and transverse directions, the tools required for standoff member manufacturing and panel tolerance control would increase the cost prohibitively.

The primary vehicle curvature and construction will strongly influence the structural spring rates of the hard points to which the panel is attached. For a given design, this interplay of loads would be incorporated during the early hardware design phase. The results of this study showed that, for the assumed primary structure, the induced loads will not significantly alter the panel design.

RECOMMENDED REFURBISHABLE PANEL SYSTEM

The recommended refurbishable system is comprised of a NASA 602 ablator which is bonded on a glass/phenolic honeycomb substrate panel of 0.375 in. (0.955 cm) depth. To this are bonded tapered cylindrical standoff cups, made of glass/phenolic material. Attachment access holes are made in the ablator-panel assembly by the use of master tools. Matched tools are then used to locate the machined aluminum tie-down fittings and bond them to the primary vehicle. The bonding materials available have temperature strength properties which will withstand the design environment used in this study.

A vehicle thermal protection system would involve a minimum of two full sets of panels and insulation--one set being a spare. A given number of representative standoff members would also be spares. All vehicle tie-down fittings would be identical and mounted on the vehicle by use of master tooling before delivery. Insulation mats would be preassembled for each panel and include a specified overlap area and holes to clear the tie-down fittings. These mats would be enclosed in an environment protection cover which would also locate the matting. Panels would also be enclosed for protection and marked for location. The tie-down nuts would be of the lock-nut variety. The only special tools involved would be a nut installation tool which would be a special ratchet or socket type tool, a manual gun for installing the panel sealer, and a panel removal tool.

The installation of the refurbishable panels follows a simple path.

- Step 1. Install preassembled insulation mats (with the protection bag).
- Step 2. Locate panel and set down over tie-down fittings (remove panel bag).
- Step 3. Install nuts and tie panel down.
- Step 4. Insert insulation plugs into attachment cups.
- Step 5. Insert ablator plugs into attachment access holes and seal.
- Step 6. Seal panel boundaries with sealing gun tool.
- Step 7. Sand ablator surface as required for flushness. Spraying the entire panel system with a sealer could then be done for appearance or protection.

The vehicle is now ready for flight. After the vehicle returns from its mission, it will be refurbished. In the Martin plasma arc facility, tests of an ablator panel with an ablator insert plug show that the insert plug is visually discernible. The steps for refurbishment are now:

- Step 8. Locate the attachment access plugs.
- Step 9. Bore out plugs with an auger bit.
- Step 10. Remove tie-down nut.
- Step 11. Cut panel boundary seal with a hand tool.
- Step 12. Remove panel via removal tool and discard.
- Step 13. Inspect for any damaged components.
- Step 14. If damage exists, replace component.

Under normal conditions the insulation mats should be reusable for a number of flights. The main danger of insulation damage would be from the panel removable procedure, and with the above operation, this should be minimal. The insulation plugs, which are placed into the attachment members, would be replaced for every flight. After the above refurbishment steps have been completed, the rest of the procedure would follow from Step 2.

The manufacturing concepts envisioned for the attachment system are as follows. The standoff members are made by molding. Representative mold tools would be made to accommodate the panel height (insulation thickness) requirements. The vehicle tie-down fittings would be machined from aluminum bar stock via automatic programming. The tie-down bolts are stock items. Insulation mat lay ups would be preassembled for specific panel areas and be consistent with insulation thickness constraints. The layers of insulation, which make up the mat, could be locally tied together to form a usable unit by the use of a nonpressure contact cement. Location of ablator-panel attachment holes and standoff members would be accomplished through the use of master tooling. Table 21 shows a summary of the refurbishable panel components and materials.

The attractiveness of this system is its simplicity and minimum number of parts. Inherent with a simple design is a high reliability, which is mandatory for a manned entry system. The key to the system success is the tooling of the system. Through the use of matched master tooling, the tolerances can be held to a minimum and interchangeability will be maintained. On the basis of 10 panels, the average cost of the attachment system and installation will be \$28.60/ft² or \$307.70/m². The cost of the ablator panel system, as per ref. 2 is \$710/ft² or \$7639/m². Therefore, the cost of the proposed attachment concept represents 3.87% of the system cost.

Two representative refurbishable panels are shown in Figures 42 and 43. These are indicative of the two extremes for the panels. The bottom panel was

not shown since it would represent an in between case geometrically and the concepts would be identical with those shown. If a 26.67-ft (8.15-m) HL-10 vehicle as a representative having a wetted area of 830 ft² (77.1 m²) is assumed, the time required for complete refurbishment would be 140 hr. Or, with four men working a 40-hr week, it would take about a week to refurbish the vehicle. The preliminary breakdown for this vehicle had 42 refurbishable panels.

Another significant factor which this concept displays is a simplicity of repair. With a set of minimum field master tools, any component of the attachment system may be replaced at the site of the vehicle.

TABLE 21. - REFURBISHABLE PANEL COMPONENT SUMMARY

Component	Material	Means of assembly
Ablator	NASA 602	Bonded with HT-424 to panel face
Substrate panel Faces Core	Phenolic/glass Phenolic/glass	Faces bonded to core using HT-424
Standoff member	Phenolic/glass	Bonded to panel face with HT-424
Vehicle tie-down fitting	Aluminum	Bonded to vehicle
Insulation	Multilayer microquartz	Layers locally cemented and mat completely bagged
Joint sealer	RTV 560	Gun inserts sealer along boundaries

CONCLUSIONS AND RECOMMENDATIONS

Several significant conclusions may be drawn as a result of this study. These are summarized below.

- (1) For the large panel sizes considered, the refurbishable panel and attachment concept is structurally feasible.
- (2) Having discrete panel support points will not significantly alter the natural structural frequency design criteria.

- (3) Local structural design problems exist at the support point areas.
- (4) Thermal conditions will govern the panel edge deflection criteria.
- (5) The preliminary design charts will provide a reasonable starting point for refurbishable panel support spacing requirements.

In addition, the study provided guidelines for further analysis. The idealization used for the panel standoff members should be refined in order to have a more comprehensive picture of load paths and stresses. For the room temperature conditions, the strength contribution of the respective bond lines and ablator should be included. Likewise, the thermal gradients should reflect the bond effect. As pointed out in a previous section of this report, the local design problems which exist at support points have more than one solution. Comprehensive analysis of these solutions must be made in order to ascertain the optimum.

As a result of this study, a number of potential study areas have been indicated. These are listed below.

- (1) The possibility that for large refurbishable panels (i. e. , crown and bottom panels), the use of a variable directional stiffness standoff member, at extreme panel locations, could significantly reduce the induced thermal stresses.
- (2) Evaluate the significance of the weight penalty involved in the primary vehicle structure due to refurbishable panel concentrated load input and thermal load feedback.
- (3) Investigate if any significant gains can be achieved by using anti-symmetric panel support patterns. (This study assumed that the primary vehicle structure hard point spacing and resulting support spacing would be a symmetrical pattern.)

For a hardware design of a refurbishable panel the following items will have to be clearly defined.

- (1) The vehicle structure hard point spacing and respective spring rates in longitudinal, normal, transverse and rotational directions must be available.
- (2) The vehicle structural load history for the design mission will define critical panel-vehicle load interaction.
- (3) Aerodynamic smoothness requirements must be defined in order to determine standoff member height variation.
- (4) Vehicle access system--to define refurbishable panel size and local panel access requirements.

- (5) Vehicle environmental data--to define critical load, thermal, and vibrational design conditions.

Along with the above information, testing would have to be done to verify and define material allowables, bond strength, core strength, joint sealer properties, and manufacturing techniques to control warpage and residual stresses.

Since the above defined block of information is not completely available, the most logical follow-on would be an element test program. A representative refurbishable panel would be built, preferably full scale or as large as possible considering test facility constraints. This panel would then be subjected to edge boundary conditions, which duplicate adjacent panels, and tested for aerodynamic and thermal design load environments. The testing would be done in separate increments of pressure and temperature and finally by a combination loading condition. Similarly, through the use of shakers and acoustic horns, the panel would be subjected to a vibrational spectrum to determine if resonant conditions exist. This test program would provide the needed structural verification testing before application to a manned entry vehicle system.

Martin Company
Baltimore, Maryland 21203
March 28, 1966

REFERENCES

- (1) Wing, L. D.; and Eilertson, W. H.: Research Studies and Analysis to Define Manned Lifting Entry Flight Environment. NASA CR-639, 1966.
- (2) LaPorte, A. H.: Research on Refurbishable Thermostructural Panels for Manned Lifting Entry Vehicles. NASA CR-638, 1966.
- (3) Kaufman, S.; and Hall, D. B.: A Digital Program for Static and Dynamic Analysis of Complex Structures. RM-136, Martin Company, Baltimore, 1963.
- (4) Boogar, E. R.; and Sallis, D. V.: Transient Heating Digital Analysis for Structural Design. RM-63, Martin Company, Baltimore, 1960.
- (5) Sparhawk, H. E.; and Syrylo, S.: RVT-53A-T-CAP III Thermochemical Ablation Program Utilization Report. Martin Company, Baltimore, 1965.
- (6) Peterson, R. E.: Stress Concentration Design Factors. John Wiley and Sons, Inc., 1962.
- (7) Bruhn, E. F.: Analysis and Design of Flight Vehicle Structure. Tri-State Offset Company, 1965.
- (8) Anon.: Composite Construction for Flight Vehicles, MIL-HDBK 23. Department of Defense, 1962.

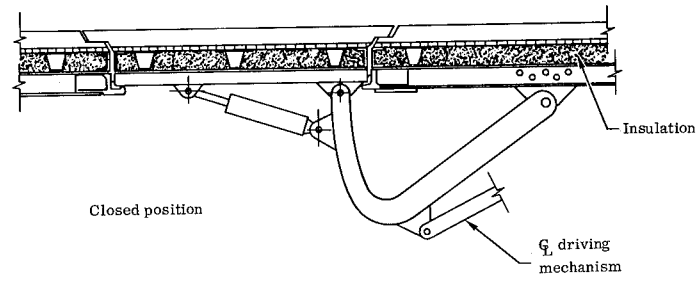

Closed position

Insulation

ζ_L driving mechanism

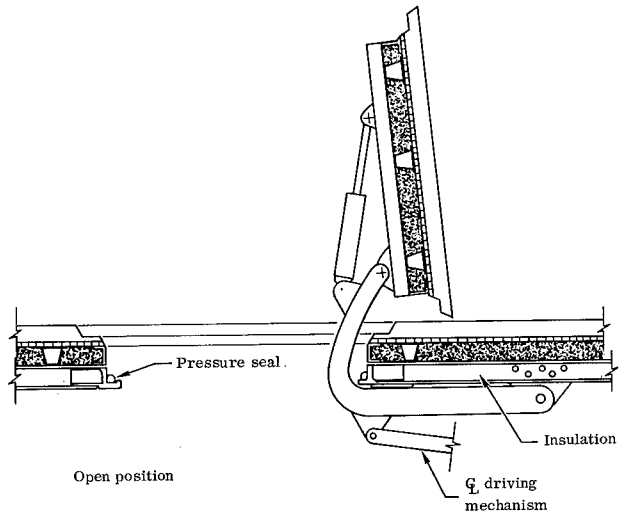

Open position

Pressure seal

Insulation

ζ_L driving mechanism

(a). THERMOSTRUCTURAL PANEL IN A HATCH AREA

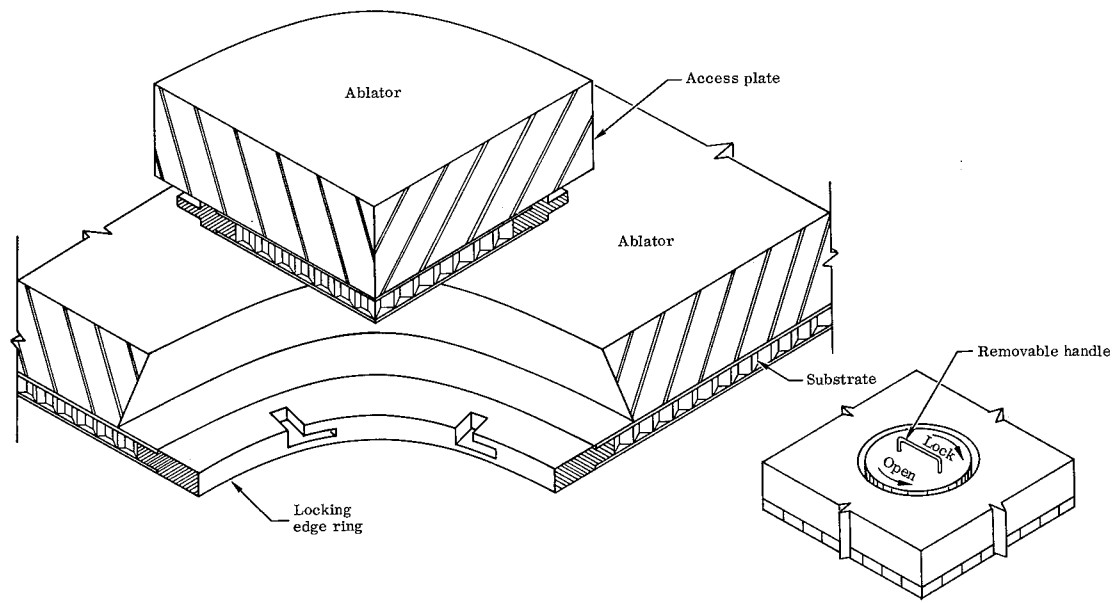

(b). REFURBISHABLE PANEL--ACCESS CONCEPT

FIGURE 1. REPRESENTATIVE HATCH HINGE SCHEME WITH REFURBISHABLE PANEL AND A LOCAL ACCESS CONCEPT

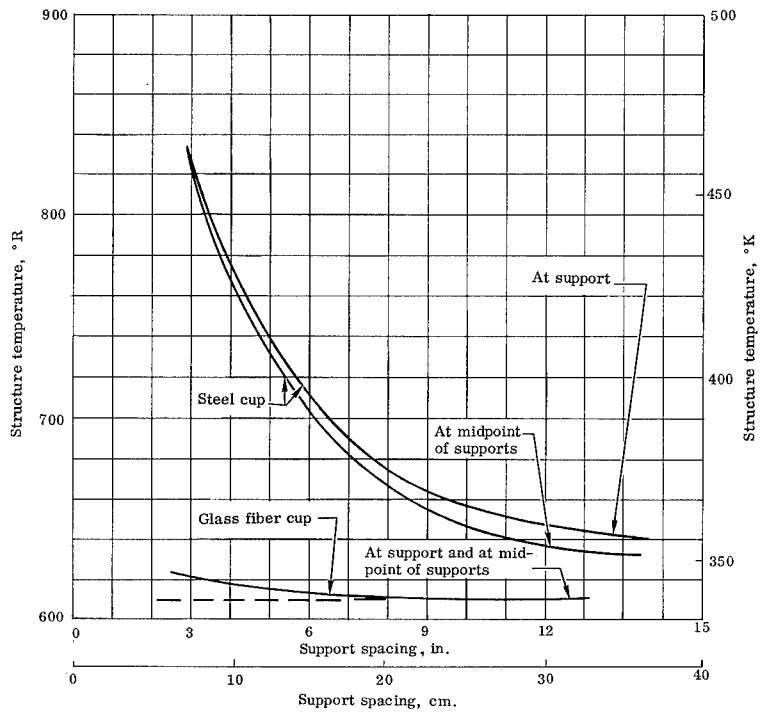

(a). STRUCTURAL ALUMINUM SKIN TEMPERATURE
 CONDITION AT TOUCHDOWN (TIME 3260 sec), OVERSHOOT
 TRAJECTORY, NO HEAT SINK, $q_L/q_{stag} = .70$, $t_{(LDNP)} =$
 1.2 in. (3.05 cm) $t_{(NASA 602)} = 1.34$ in. (3.4 cm)

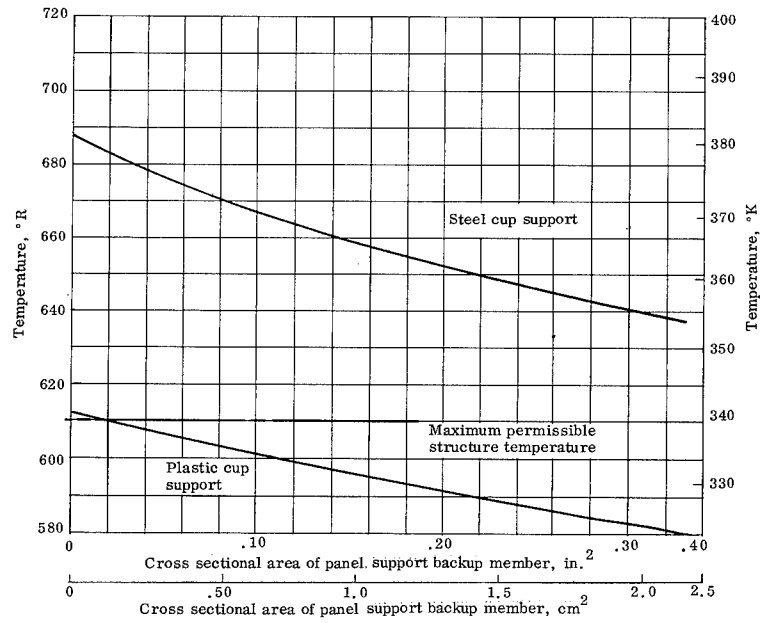

(b). STRUCTURAL ALUMINUM SKIN TEMPERATURE WITH HEAT SINK
 [MAXIMUM STRUCTURE TEMPERATURE AT TOUCHDOWN, OVERSHOOT
 TRAJECTORY, $q_L/q_{stag} = .70$, SUPPORT SPACING =
 7.0 in. (17.8 cm)]

FIGURE 2. HEATSHORT STUDY

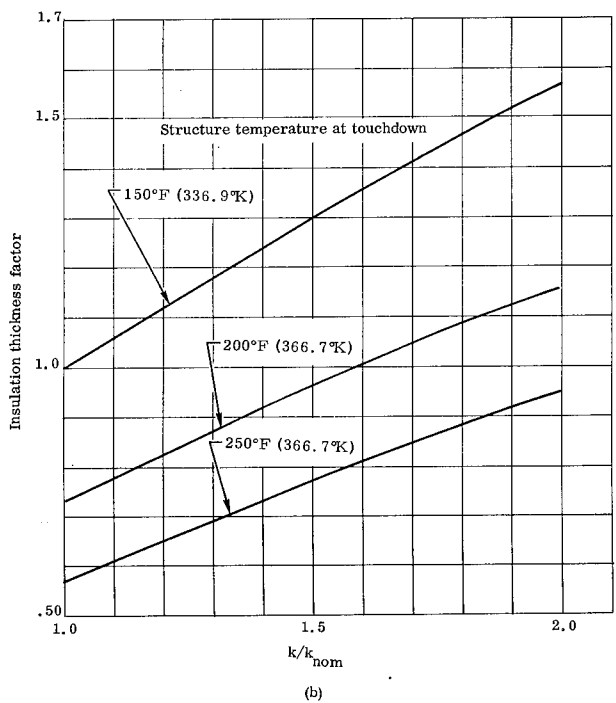
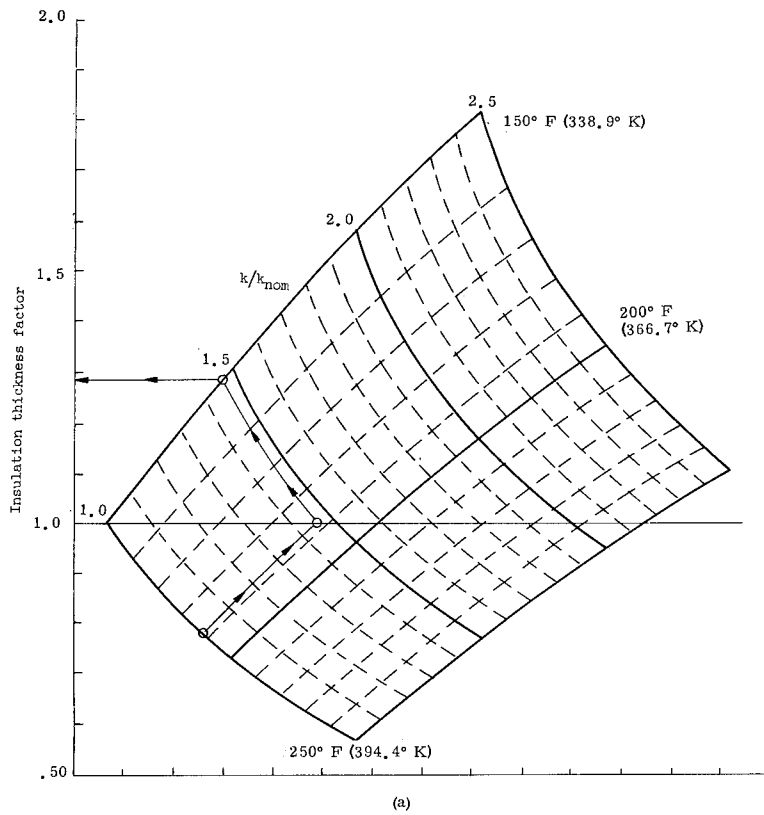

FIG. 3. INSULATION CONDUCTIVITY/THICKNESS INTERACTION (OVERSHOOT RE-ENTRY, $q_L/q_{stag} = .70$, $t = 1.20$ IN. FOR LDNP, $t_{ins} = 1.34$ IN. FOR NOMINAL INSULATION)

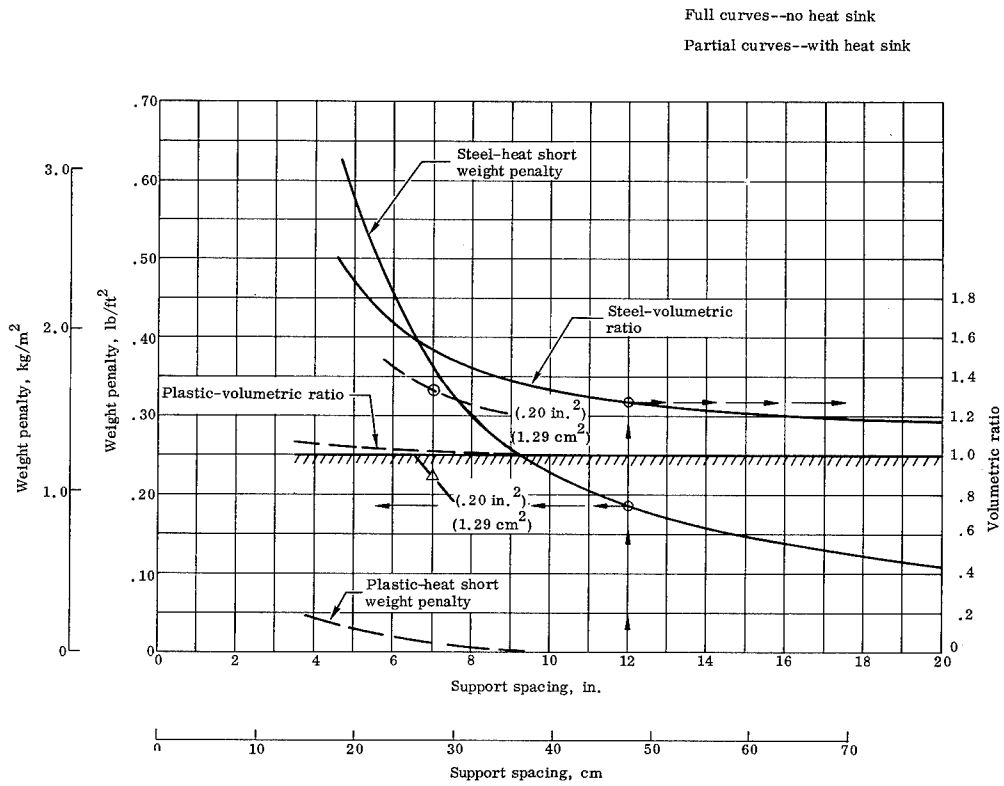

FIGURE 4. WEIGHT AND VOLUMETRIC PENALTY FOR PLASTIC AND STEEL STANDOFF TO MAINTAIN 610°R (338°K) VEHICLE STRUCTURAL TEMPERATURE

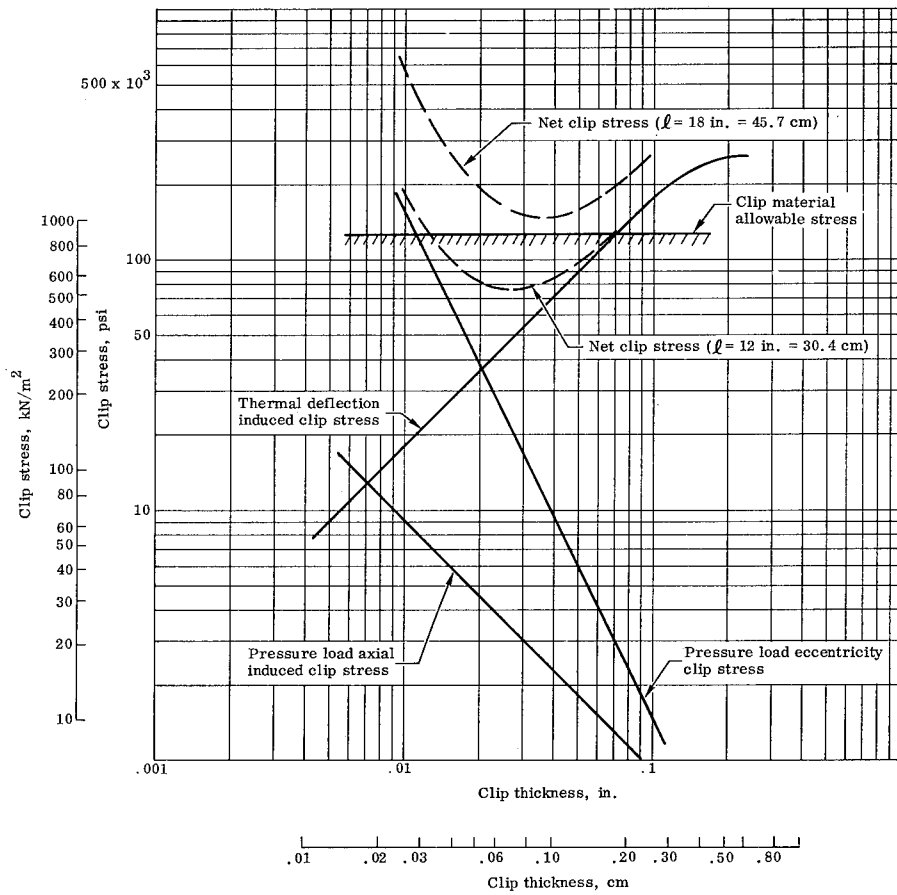

FIGURE 5. FLEXIBLE CLIP STRESSES [(STEEL SUBSTRATE WITH STEEL CLIPS, TEMPERATURE = 1260°R (700°K), PRESSURE = 2.73 psi (18.1 kN/m²)]

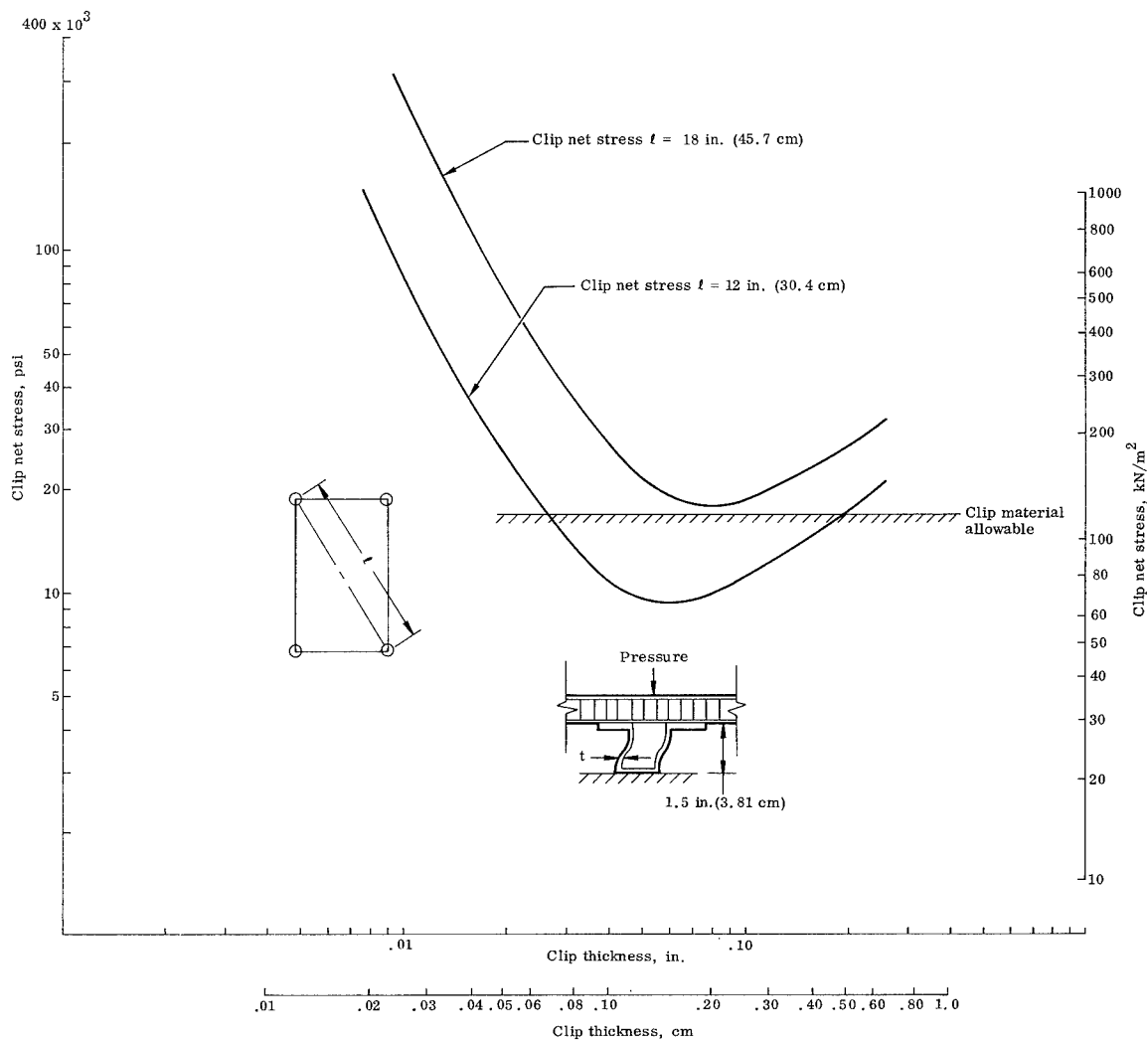
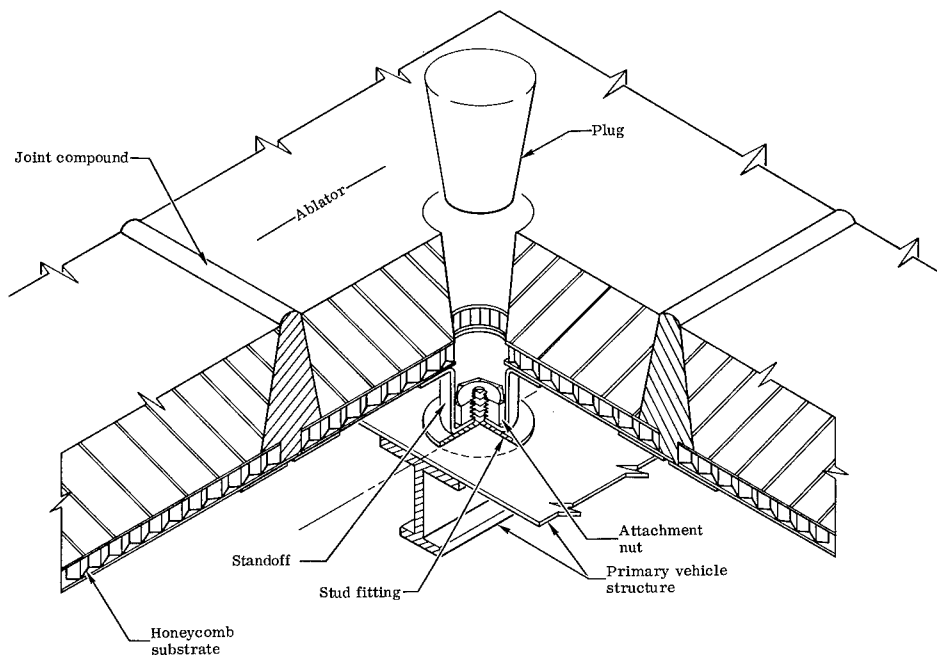
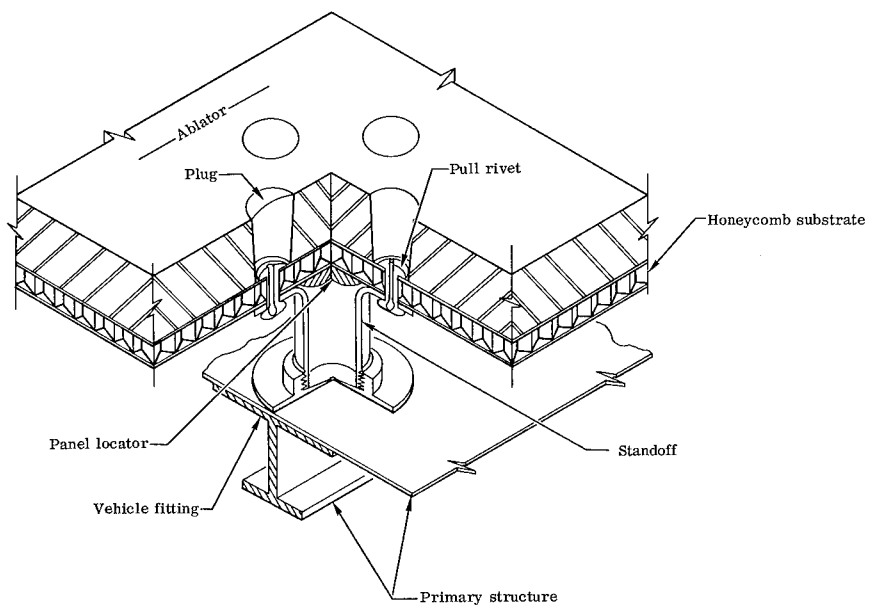

FIGURE 6. FLEXIBLE CLIP STRESSES [PHENOLIC GLASS SUBSTRATE AND CLIP, TEMPERATURE = 1260°R (700°K), PRESSURE = 2.73 psi (18.1 kN/m²)]



(a) Concept 1



(b) Concept 2

FIGURE 7. PANEL ATTACHMENT

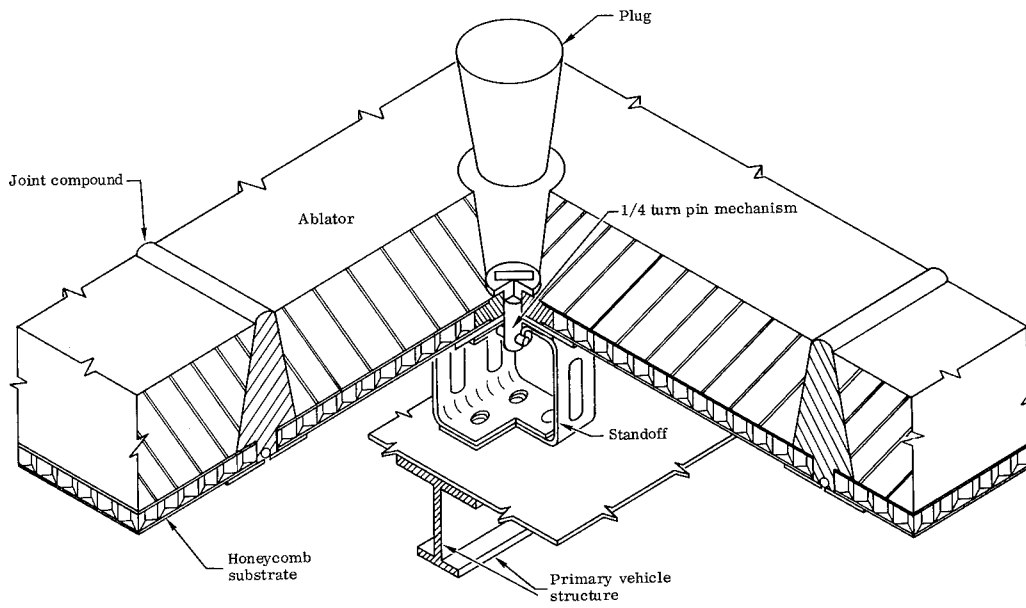

(c) Concept 3

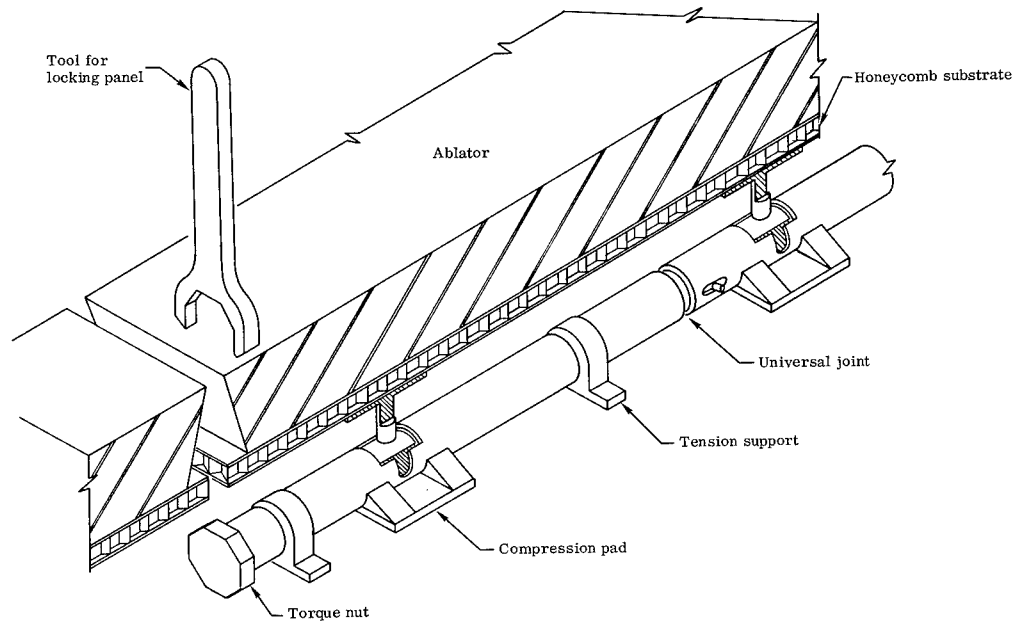

(d) Concept 4

FIGURE 7. -CONTINUED

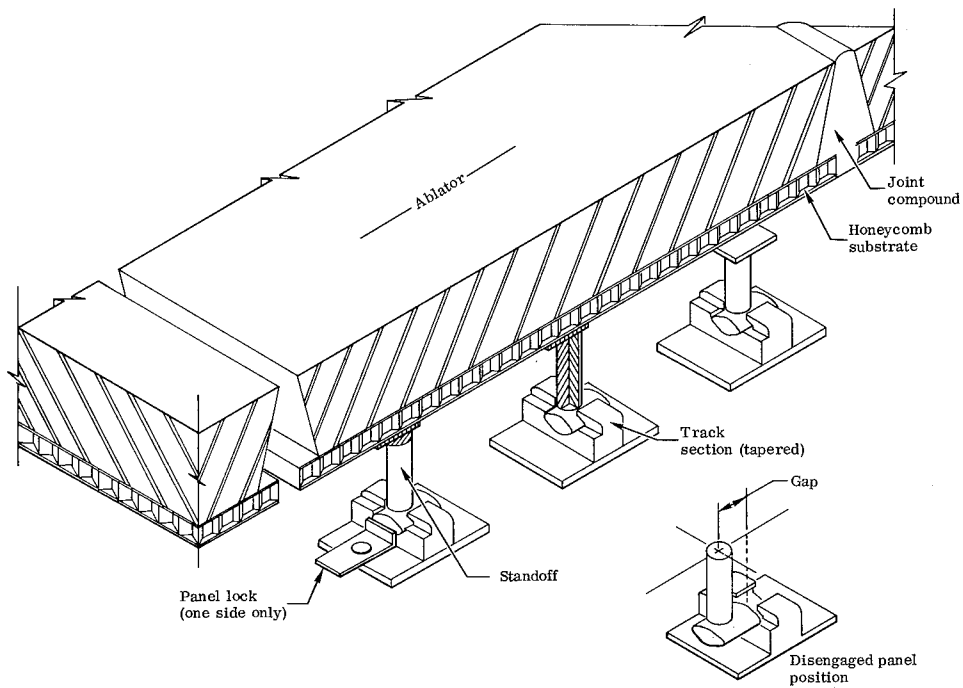

(e) Concept 5

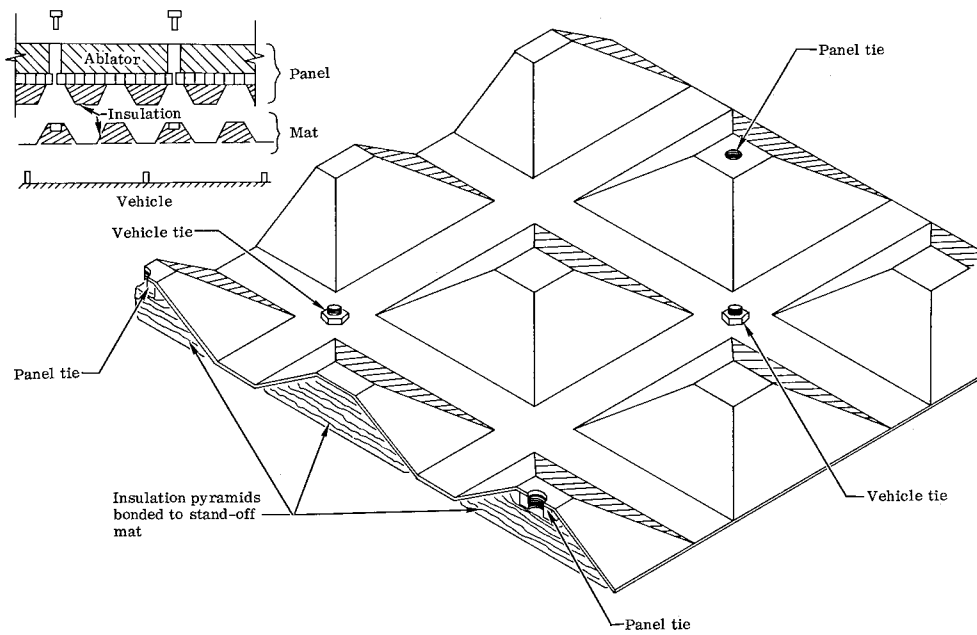

(f) Concept 6

FIGURE 7. CONCLUDED

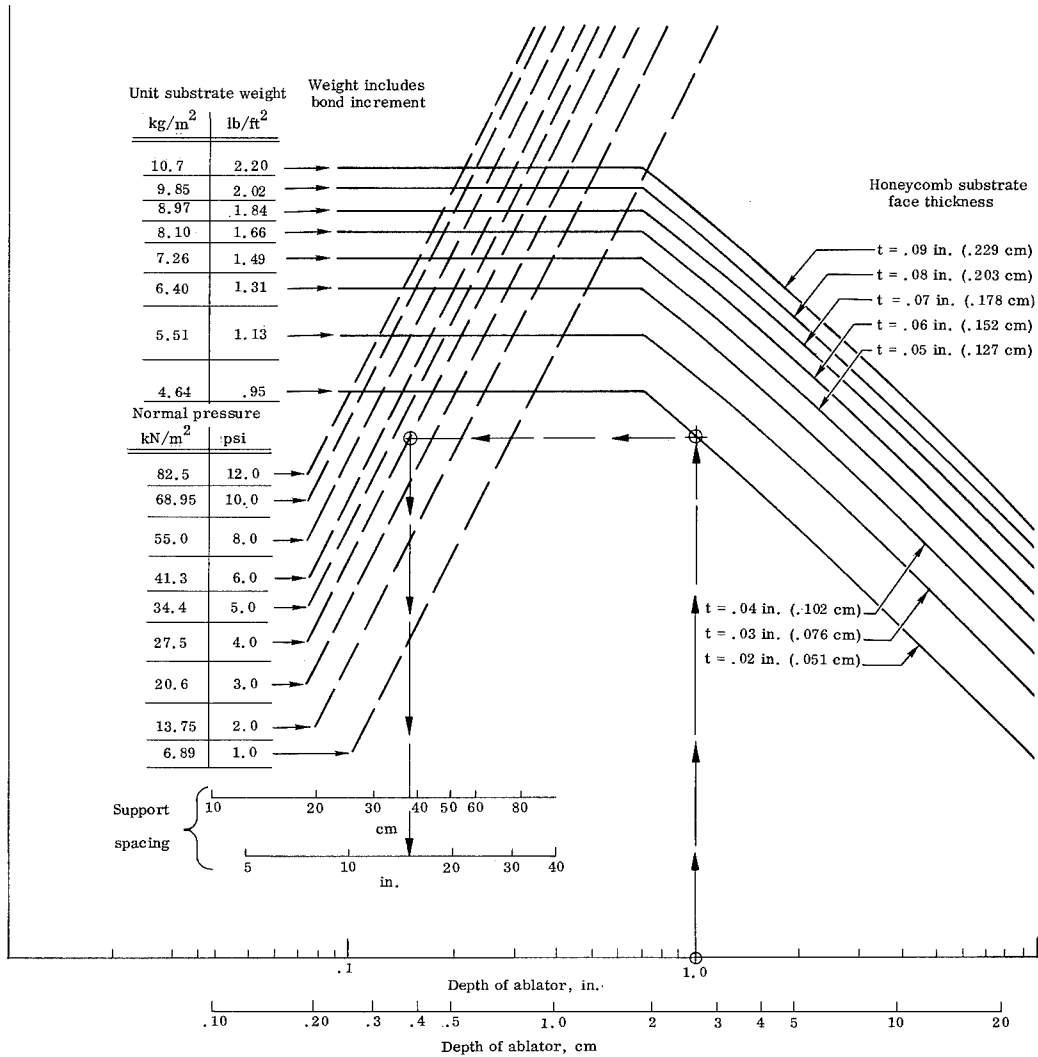
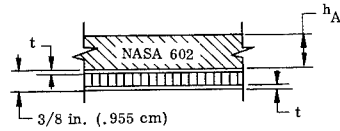

FIGURE 8. REQUIRED SUPPORT SPACING [PHENOLIC/GLASS SUBSTRATE PANEL WITH NASA 602, ABLATOR PANEL TEMPERATURE = 585°R (325°K), 3/8 in. (.955 cm) DEPTH PANEL]

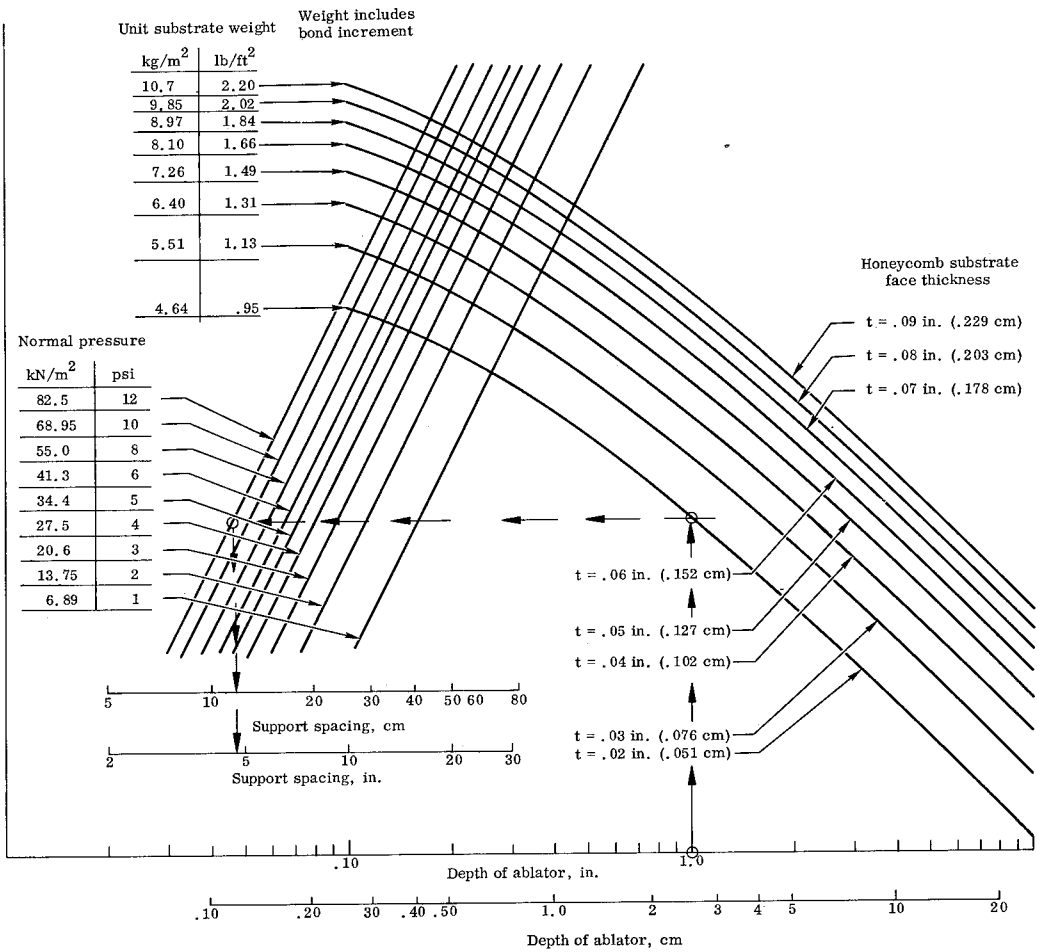
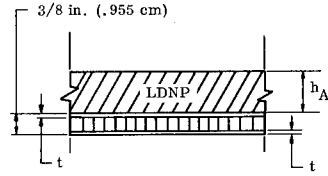

FIGURE 9. REQUIRED SUPPORT SPACING VERSUS PRESSURE [PHENOLIC/GLASS SUBSTRATE PANEL WITH LDNP ABLATOR, PANEL TEMPERATURE = 585° R (325° K)]

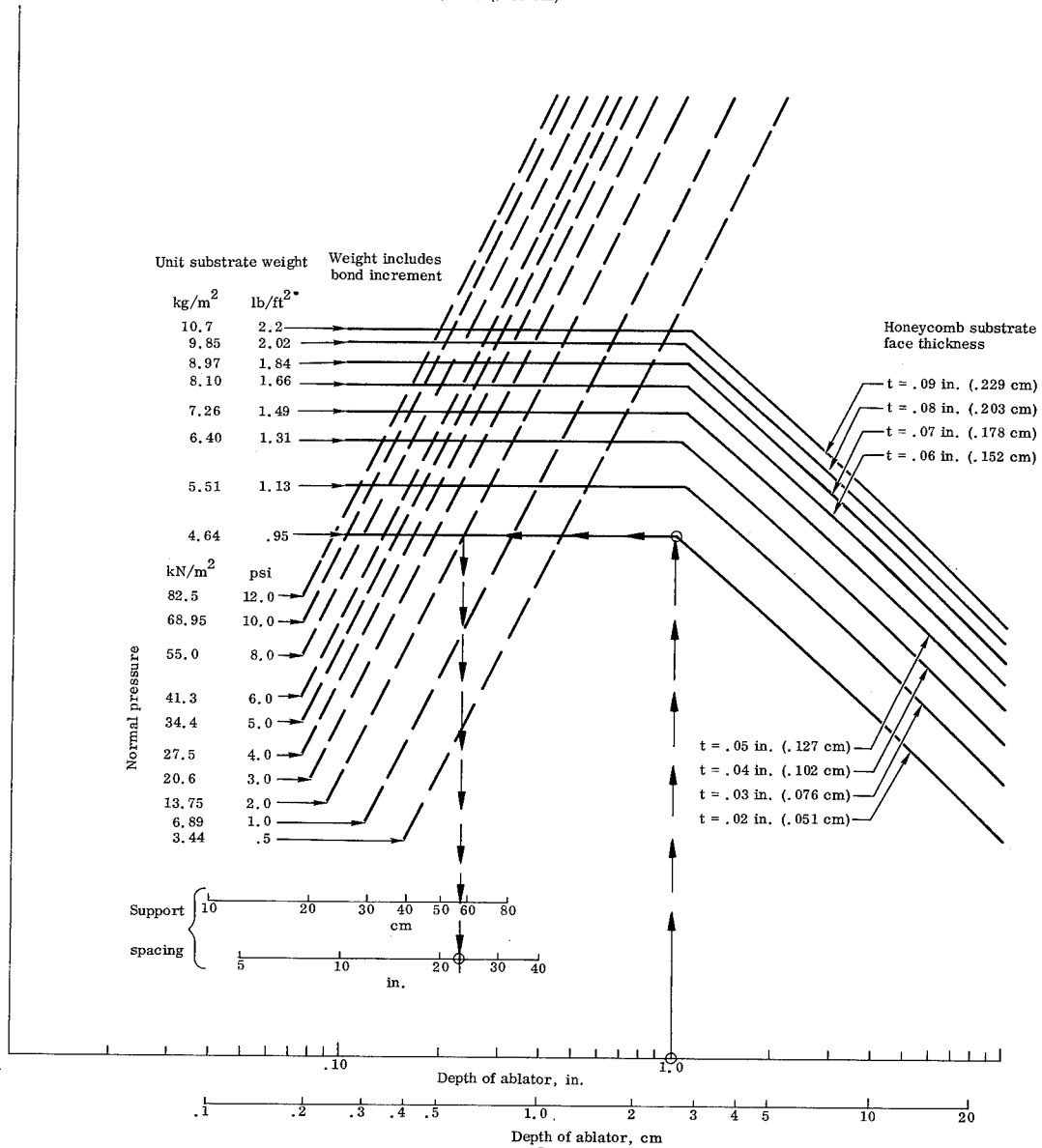
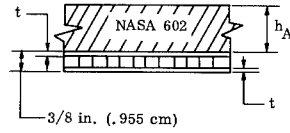

FIGURE 10. REQUIRED SUPPORT SPACING [PHENOLIC/GLASS SUBSTRATE PANEL WITH NASA 602 ABLATOR, PANEL TEMPERATURE = 740°R (411°K), 3/8 in. (.955 cm) DEPTH PANEL]

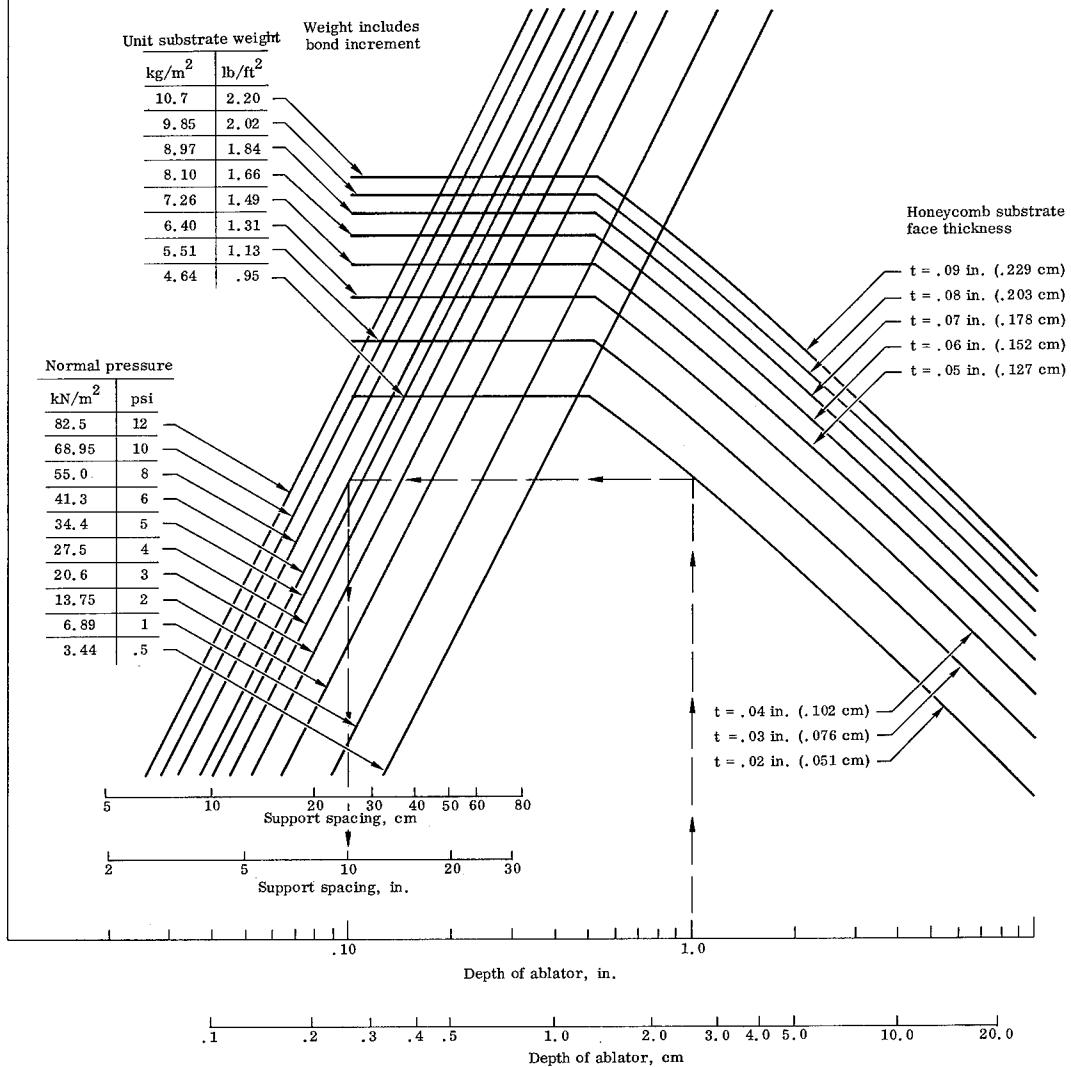
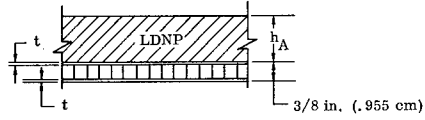

FIGURE 11. REQUIRED SUPPORT SPACING VERSUS PRESSURE [PHENOLIC/GLASS SUBSTRATE PANEL WITH LDNP ABLATOR, PANEL TEMPERATURE = 740°R (411°K)]

Unit substrate weight (Weight includes bond increment)

	kg/m ²	lb/ft ²
8	10.7	2.2
7	9.85	2.02
6	8.97	1.84
5	8.10	1.66
4	7.26	1.49
3	6.40	1.31
2	5.51	1.13
1	4.64	.95

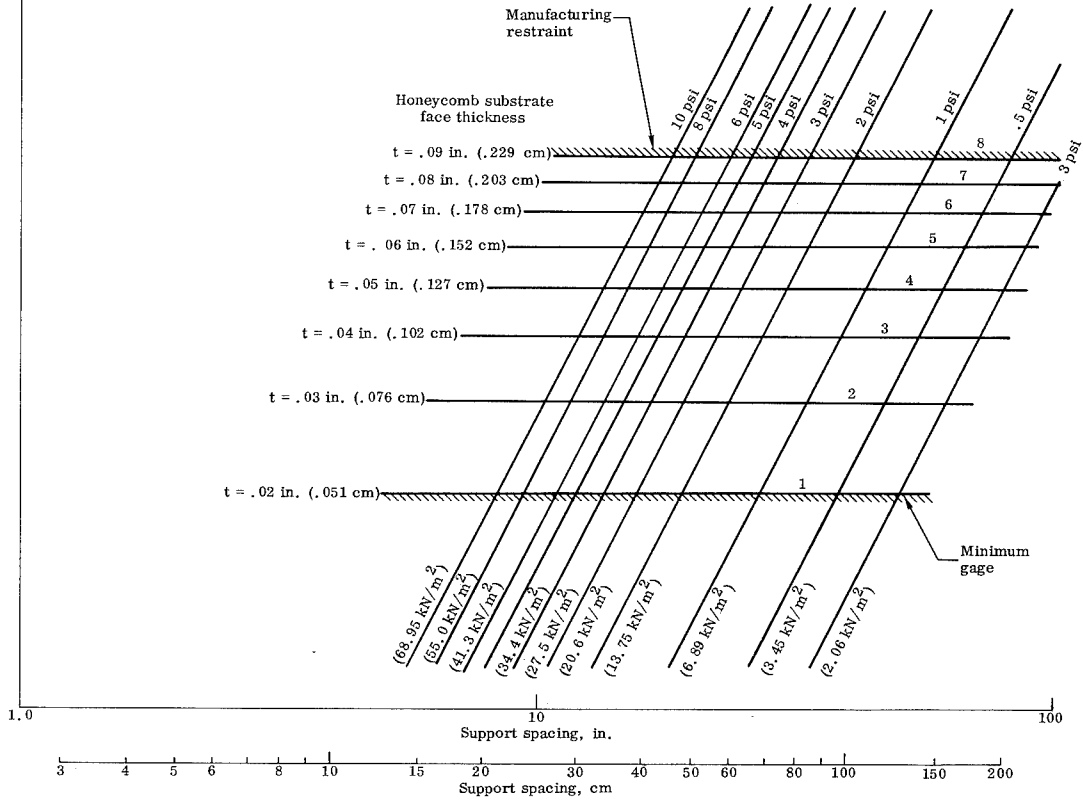
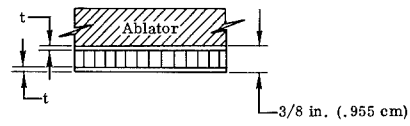

FIGURE 12. REQUIRED SUPPORT SPACING VERSUS PRESSURE FOR NASA 602 OR LDNP ABLATOR [PHENOLIC/GLASS SUBSTRATE PANEL, PANEL TEMPERATURE = 1080° R (600° K)]

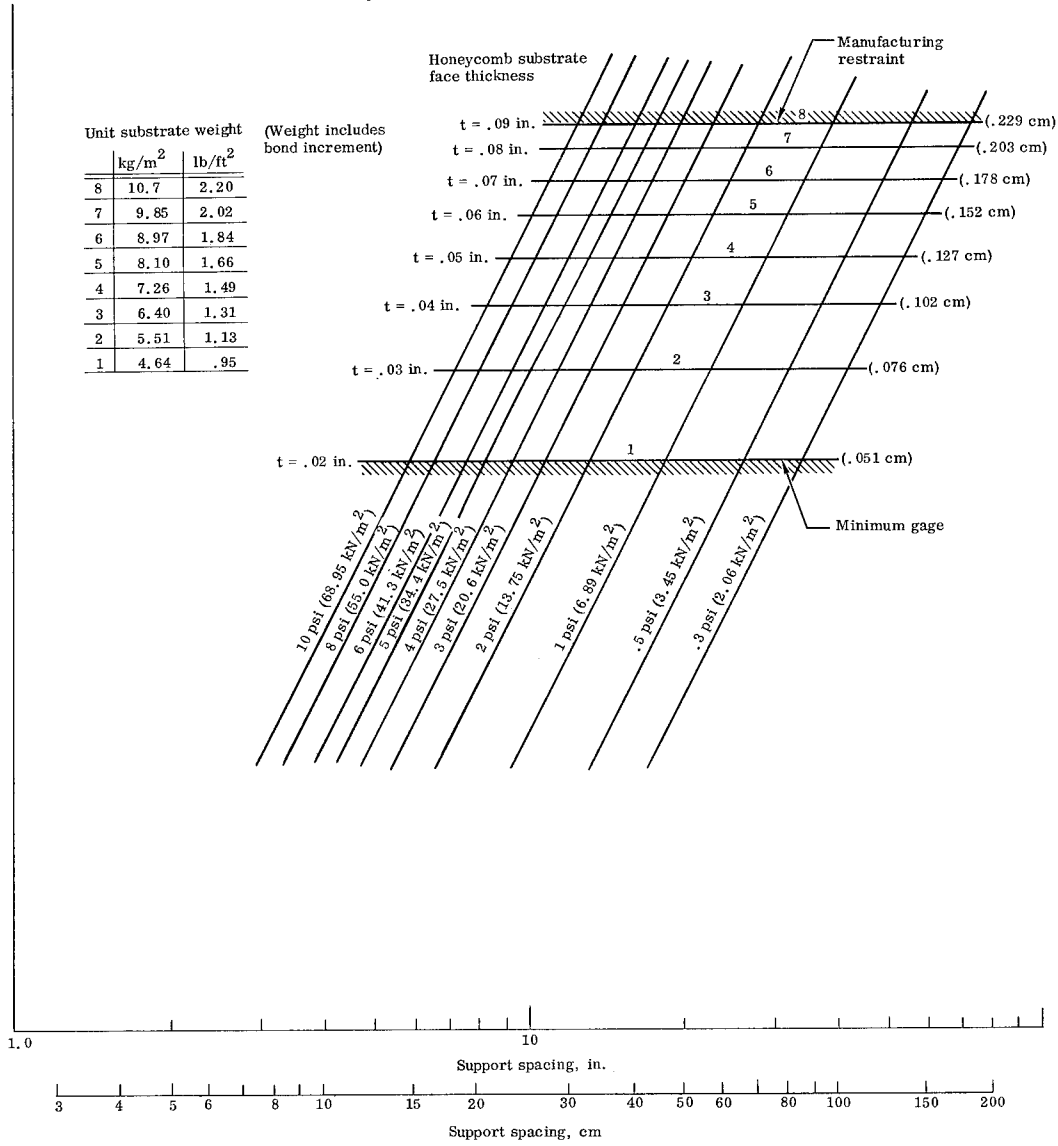
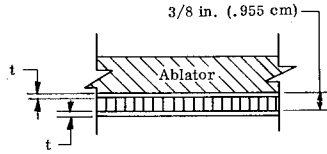
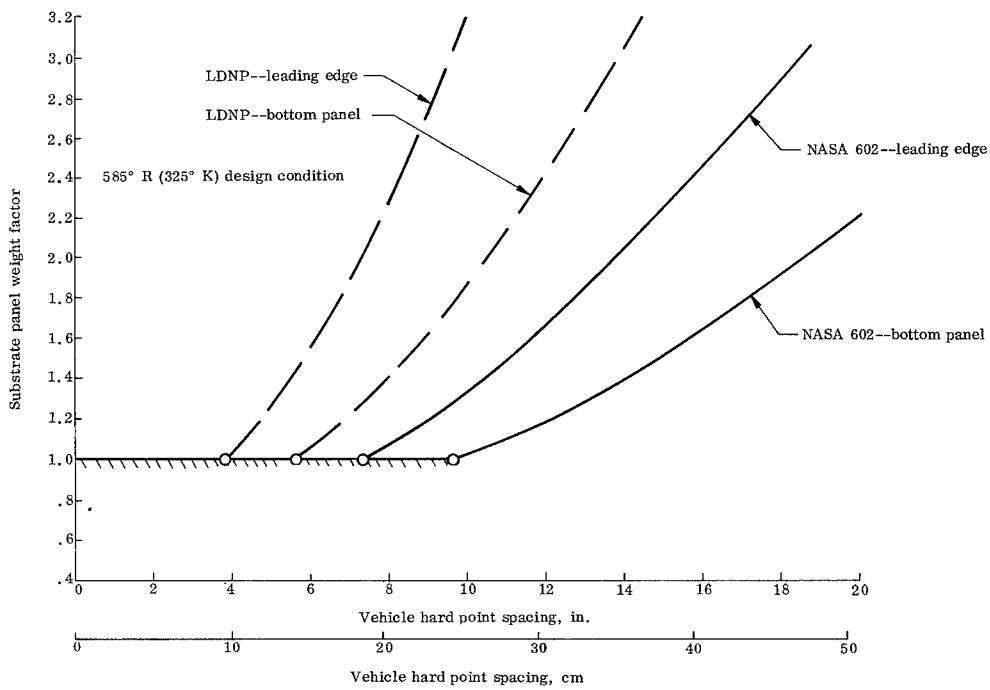
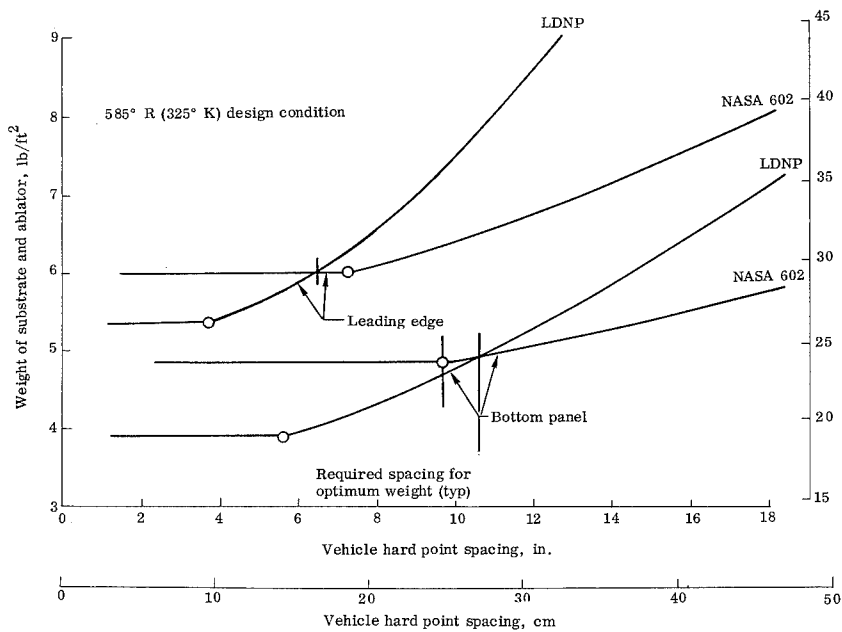

FIGURE 13. REQUIRED SUPPORT SPACING VERSUS PRESSURE FOR NASA 602 OR LDNP ABLATOR [PHENOLIC/GLASS SUBSTRATE PANEL, PANEL TEMPERATURE = 1260° R (700° K)]



(a). SENSITIVITY OF VEHICLE HARD POINT SPACING (SUBSTRATE PANEL WEIGHT SENSITIVITY)



(b). PANEL WEIGHT SENSITIVITY

FIGURE 14. EFFECTS OF VEHICLE HARD POINT SPACING

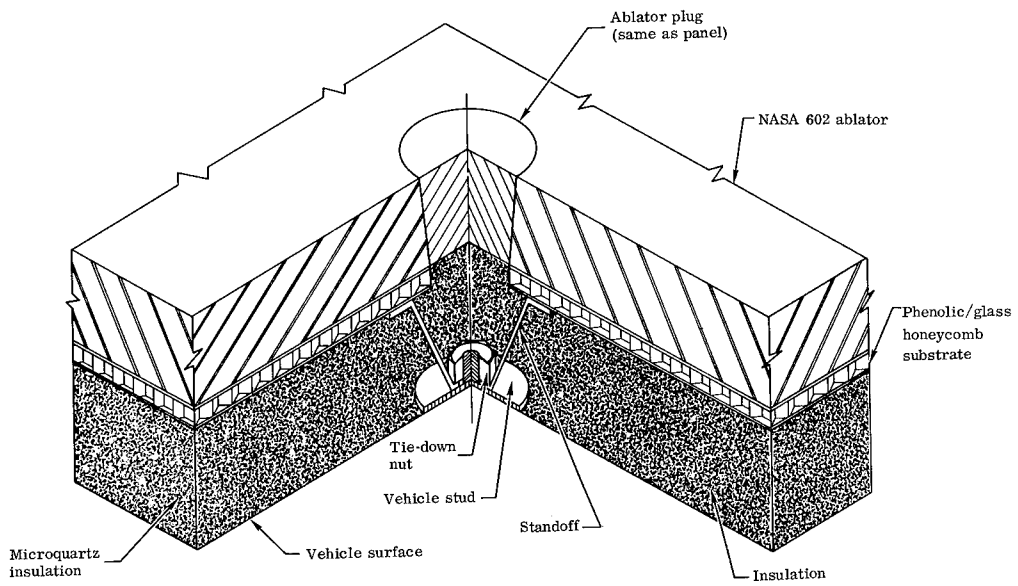

FIGURE 15. SELECTED REFURBISHABLE PANEL CONCEPT

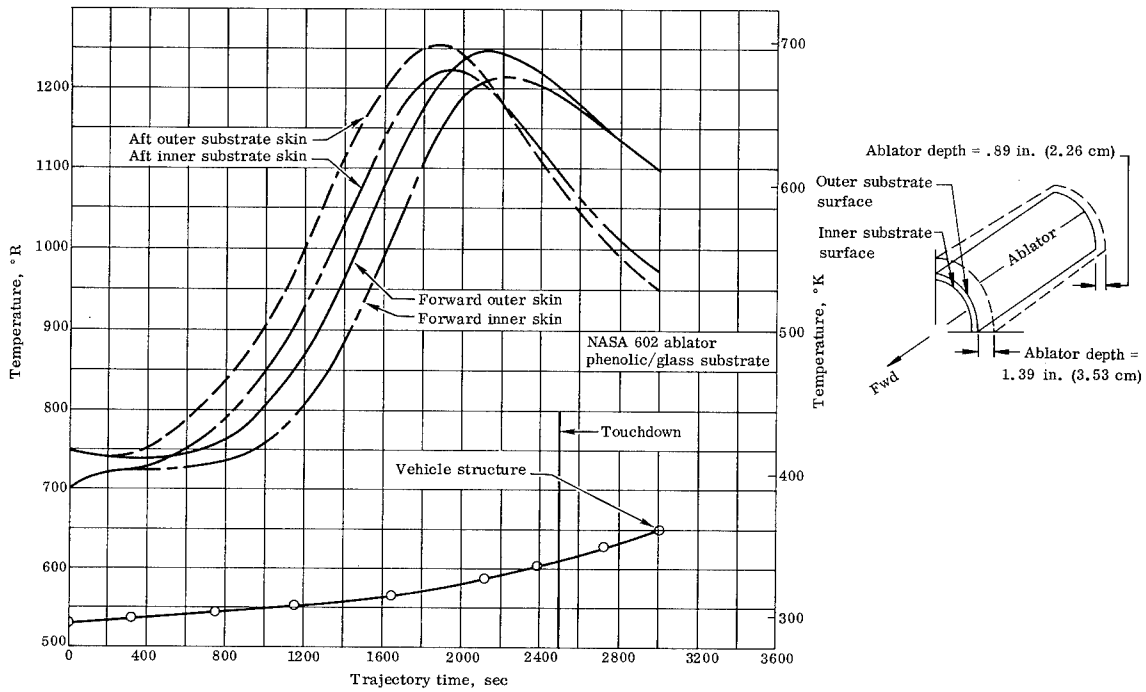

FIGURE 16. CRITICAL TEMPERATURE HISTORY OF LEADING EDGE PANEL (NOMINAL TRAJECTORY)

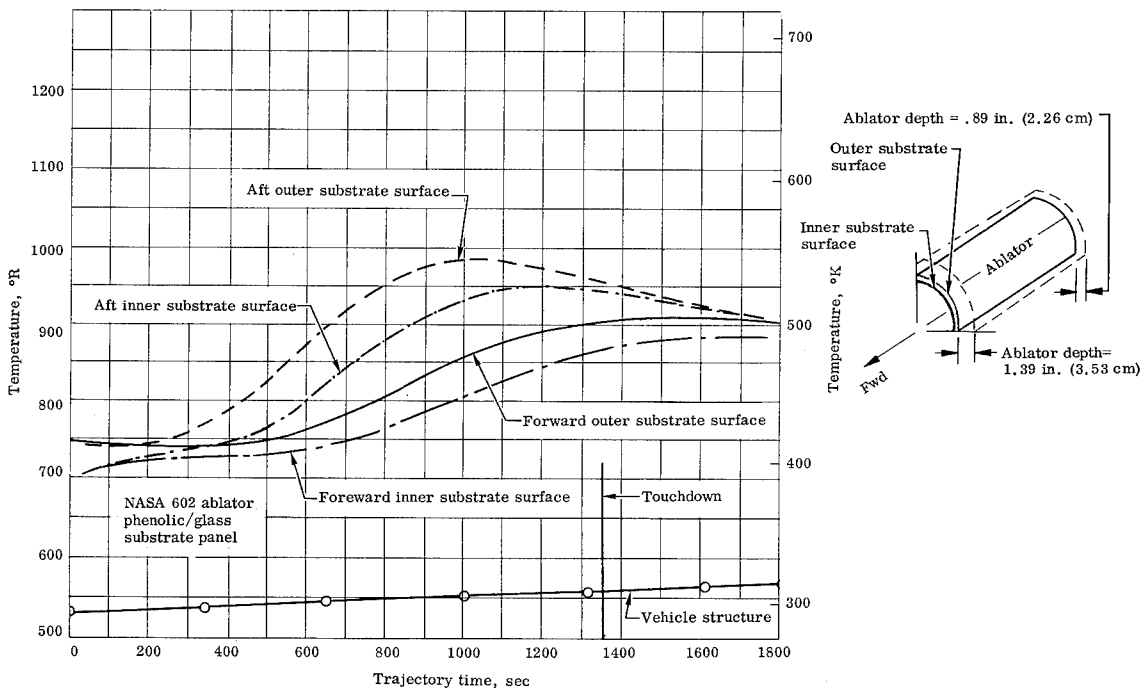

FIGURE 17. TEMPERATURE-HISTORY OF LEADING EDGE PANEL (UNDERSHOOT TRAJECTORY)

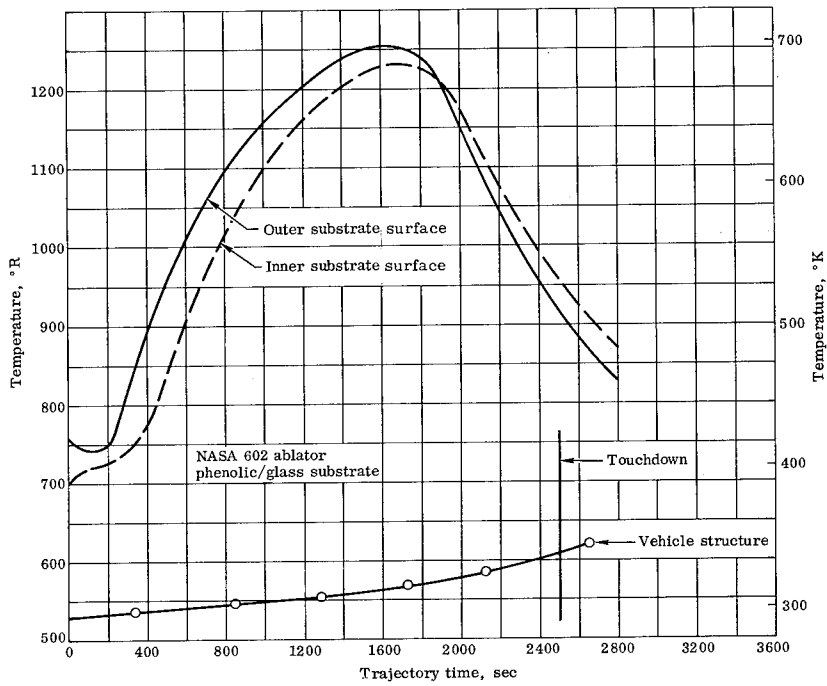
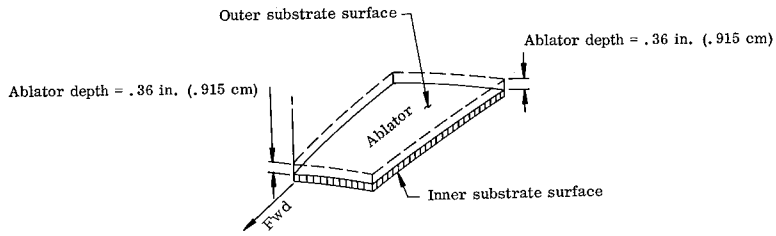

FIGURE 18. TEMPERATURE HISTORY OF CROWN PANEL (NOMINAL TRAJECTORY)

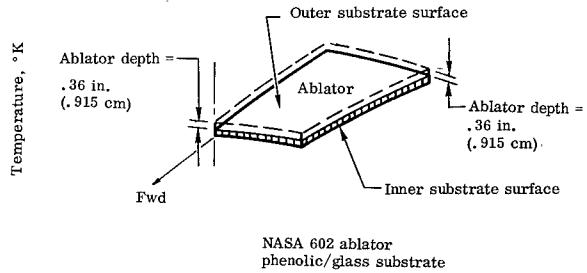
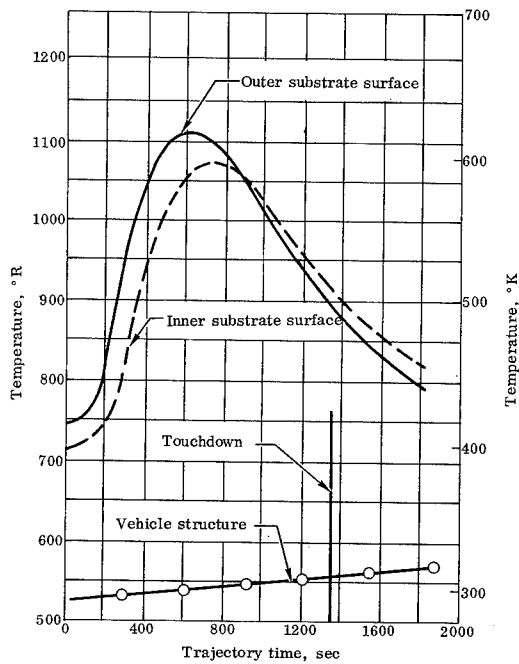

FIGURE 19. TEMPERATURE HISTORY OF CROWN PANEL (UNDERSHOOT TRAJECTORY)

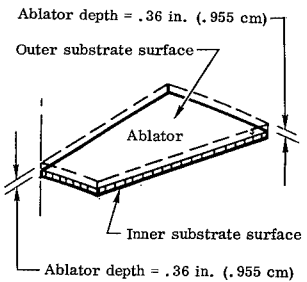
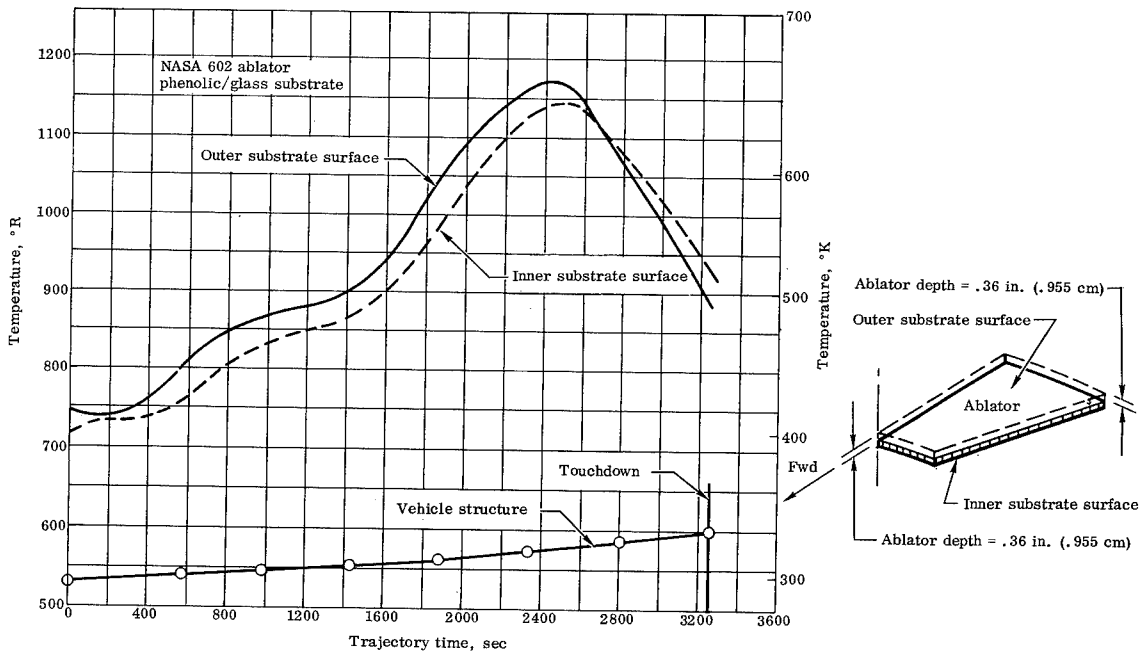

FIGURE 20. TEMPERATURE HISTORY OF CROWN PANEL (OVERSHOOT TRAJECTORY)

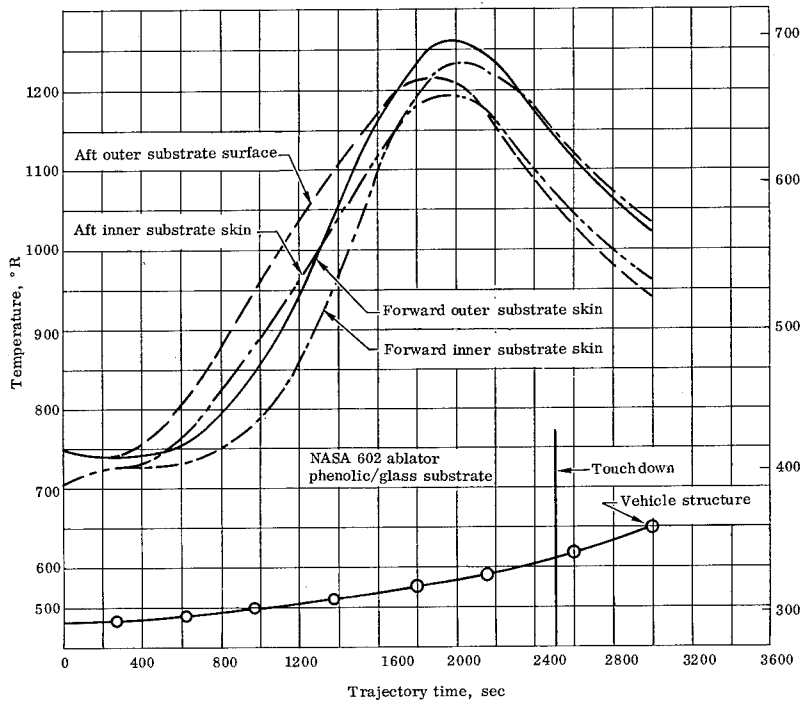

FIGURE 21. TEMPERATURE-HISTORY OF BOTTOM PANEL (NOMINAL TRAJECTORY)

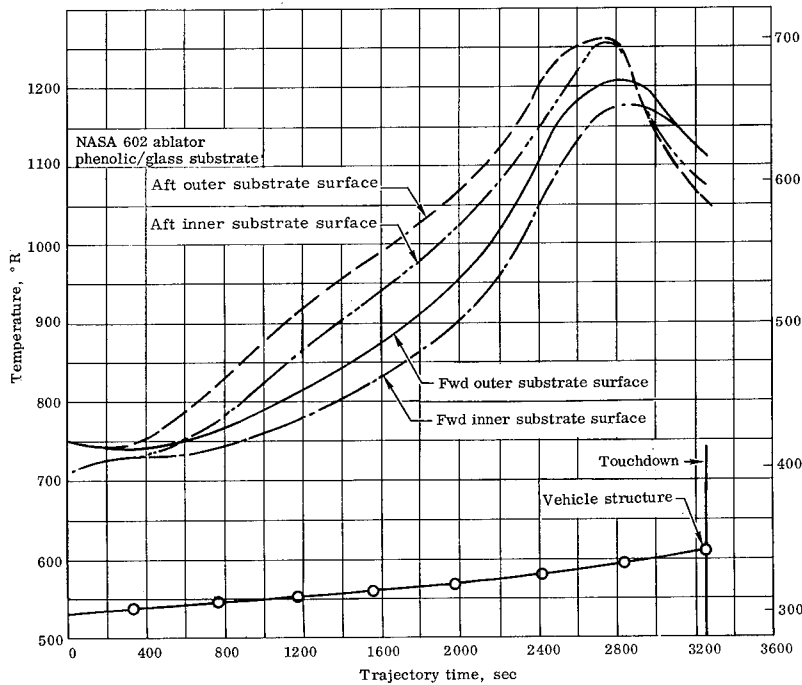
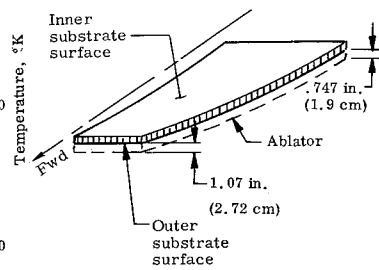
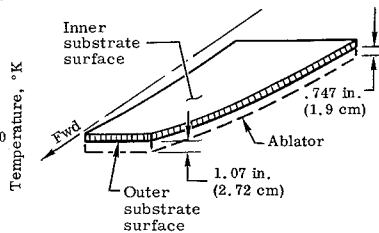

FIGURE 22. TEMPERATURE-HISTORY OF BOTTOM PANEL (OVERSHOOT TRAJECTORY)



Panel	Critical load designation	Ultimate surface normal pressure		Substrate panel temperature °K*				Corresponding NASA 602 ablator thickness				Maximum allowable stress differential ** F _{US} - F _{LS} ALL.	Condition
				Outer surface		Inner surface							
		psi	kN/m ²	T _{Fwd}	T _{Aft}	T _{Fwd}	T _{Aft}	t _{Fwd}	t _{Aft}	t _{Fwd}	t _{Aft}		
Leading edge	L-1	12.75	88.1	--	--	--	--	1.386 in.	3.52 cm	.89 in.	2.26 cm	61.0 ksi 420.5 MN/m ²	Abort
	L-2	2.48	17.1	543	614	495	572	↓	↓	↓	↓		Nominal
	L-3	3.90	26.9	652	695	616	672	↓	↓	↓	↓		Nominal
	L-4	9.95	68.6	410	410	400	400	↓	↓	↓	↓		Undershoot
	L-5	--	--	214	214	227	227	↓	↓	↓	↓		Cold soak
Crown	C-1	1.73	11.9	--	--	--	--	.36 in.	.915 cm	.36 in.	.915 cm	120.0 ksi 827.5 MN/m ²	Abort
	C-2	.35	2.41	700	700	685	685	↓	↓	↓	↓		Nominal
	C-3	.30	2.07	536	536	461	461	↓	↓	↓	↓		Undershoot
	C-4	.62	4.27	641	641	634	634	↓	↓	↓	↓		Overshoot
	C-5	--	--	224	224	240	240	↓	↓	↓	↓		Cold soak
Bottom	B-1	8.73	60.2	--	--	--	--	.95 in.	2.42 cm	.747 in.	1.90 cm	82.0 ksi 565.0 MN/m ²	Abort
	B-2	.05	.344	478	540	428	514	↓	↓	↓	↓		Overshoot
	B-3	2.73	18.8	670	660	700	684	↓	↓	↓	↓		Nominal
	B-4	--	--	214	214	227	227	↓	↓	↓	↓		Cold soak

*Reference thermal analysis temperature = 383° K

**Maximum allowable tension stress differential in panel skin upper and lower surface.
This is based on a maximum permissible ablator strain at room temperature

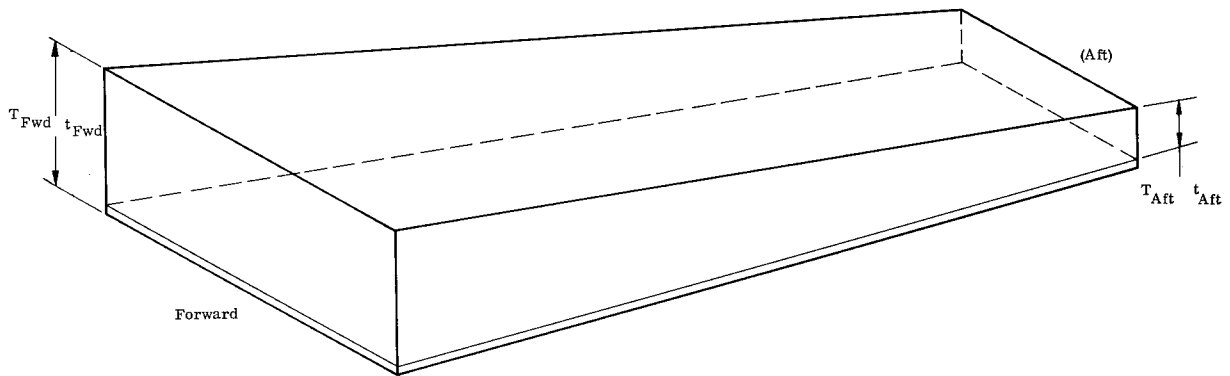

FIGURE 23. EXTERNAL PRESSURE AND THERMAL LOAD CONDITIONS (ABLATOR THICKNESS VARIATION)

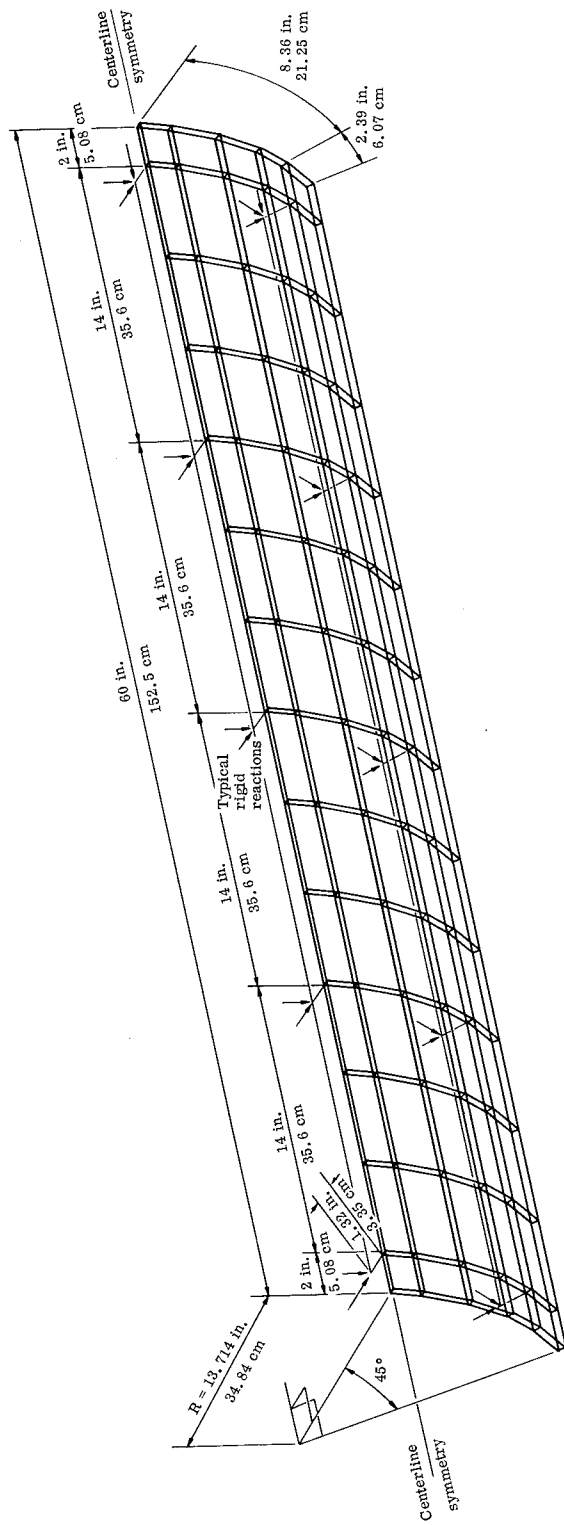

FIGURE 24. LEADING EDGE PANEL GEOMETRY

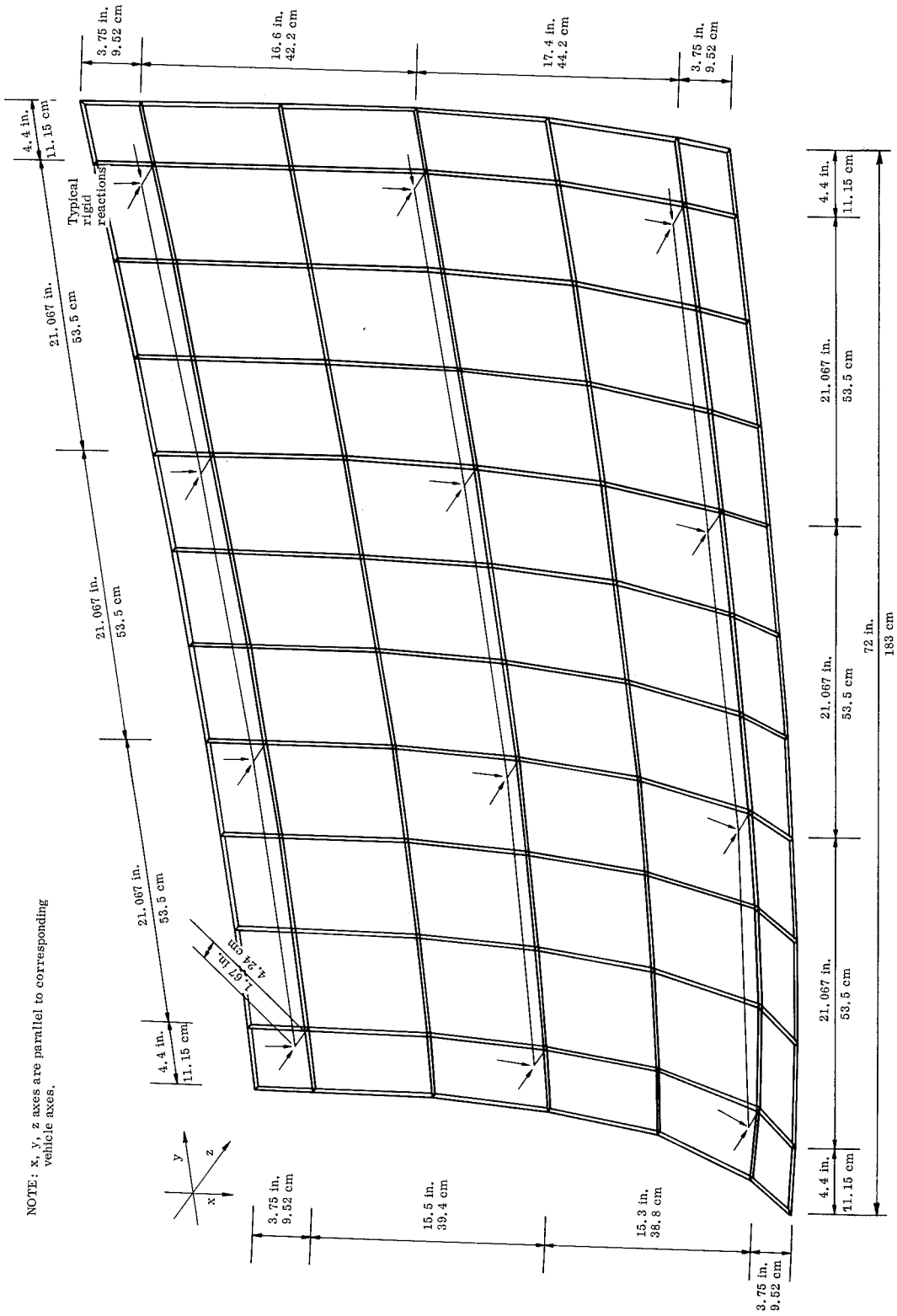

FIGURE 25. CROWN PANEL GEOMETRY

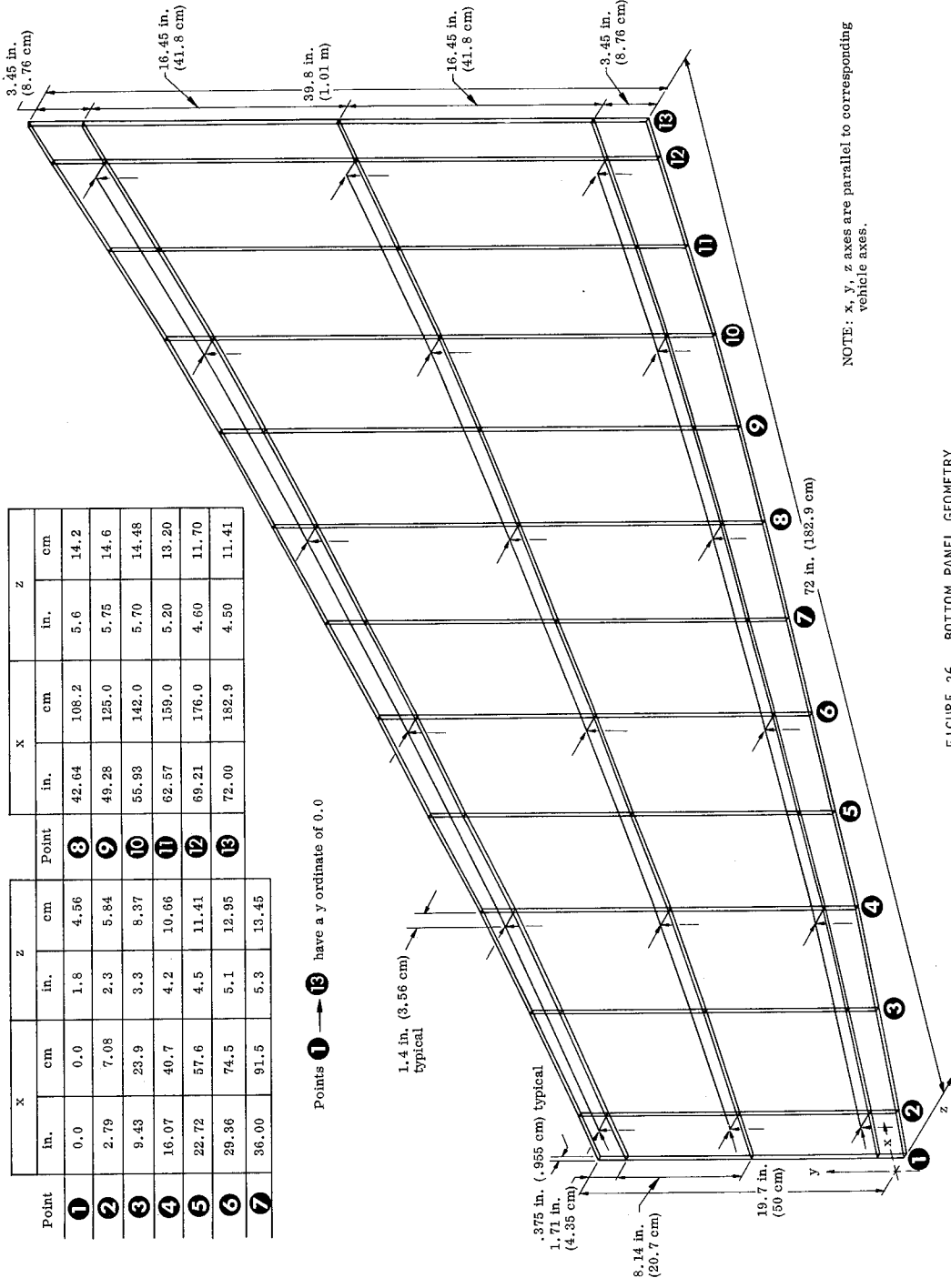
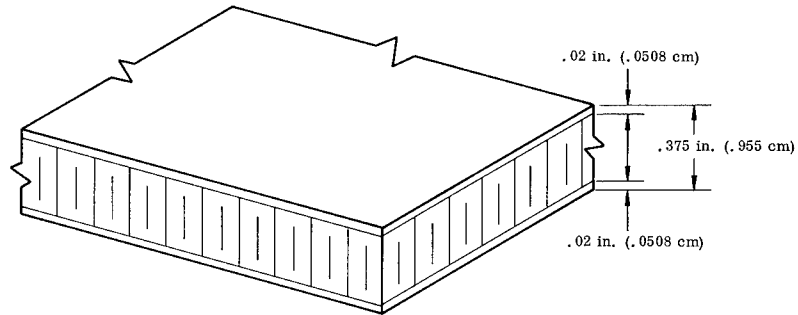

FIGURE 26. BOTTOM PANEL GEOMETRY



(a) PLASTIC SANDWICH PANEL; PHENOLIC GLASS

Heat resistant
phenolic honeycomb
core $\nu = .2$
 $G_{\text{strong direction}} = .0236 \times 10^6 \text{ psi}$
 $(.162 \text{ GN/m}^2)$
 $G_{\text{weak direction}} = .0161 \times 10^6 \text{ psi}$
 $(.1108 \text{ GN/m}^2)$
 Core weight = 5.5 lb/ft^3
 (88.1 kg/m^3)

Temperature	Core allowable			
	F_s strong		F_s weak	
535° R	505 psi	$3.47 \frac{\text{MN}}{\text{m}^2}$	275 psi	$1.89 \frac{\text{MN}}{\text{m}^2}$
860° R (478° K)	360 psi	$2.48 \frac{\text{MN}}{\text{m}^2}$	190 psi	$1.30 \frac{\text{MN}}{\text{m}^2}$
1260° R (700° K)	190 psi	$1.31 \frac{\text{MN}}{\text{m}^2}$	75 psi	$.515 \frac{\text{MN}}{\text{m}^2}$

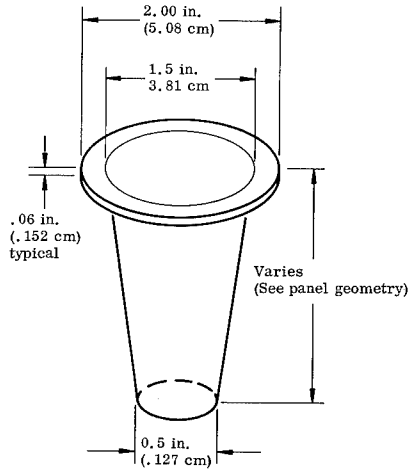

Phenolic glass strength properties

$\nu = .2$

(b) TAPERED CUP PANEL POST SUPPORT; PHENOLIC GLASS

Temperature		Young's modulus		Allowable stress	
535° R	294° K	$4.5 \times 10^6 \text{ psi}$	$31 \frac{\text{GN}}{\text{m}^2}$	60,000 psi	$412 \frac{\text{MN}}{\text{m}^2}$
860° R	478° K	$4.0 \times 10^6 \text{ psi}$	$27.6 \frac{\text{GN}}{\text{m}^2}$	49,000 psi	$337 \frac{\text{MN}}{\text{m}^2}$
1260° R	700° K	$2.59 \times 10^6 \text{ psi}$	$17.8 \frac{\text{GN}}{\text{m}^2}$	17,000 psi	$117 \frac{\text{MN}}{\text{m}^2}$

FIGURE 27. TYPICAL PANEL POST SUPPORT AND SANDWICH PANEL CROSS SECTION

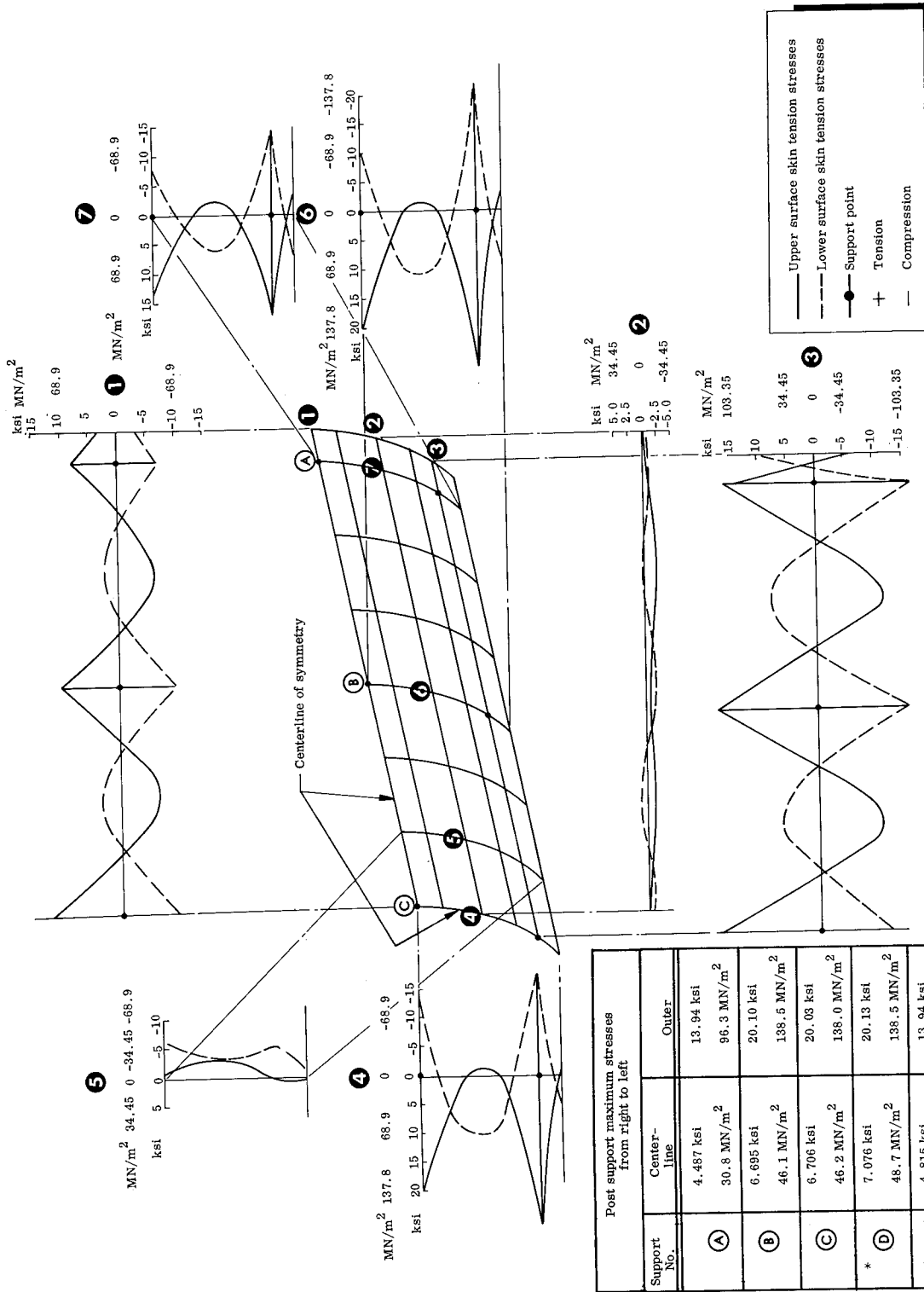

*Appears in adjacent quadrant to left.

FIG. 28. LEADING EDGE AIRLOAD PRESSURE STRESSES [PANEL SKIN TENSION AND POST SUPPORT STRESSES DUE TO NORMAL SURFACE PRESSURE; LOAD OF 12.75 PSI (88.1 kN/m²) AT ROOM TEMPERATURE (CONDITION L-1, FIGURE 23)]

Support No.	Post support maximum stresses from right to left	
	Center-line	Outer
(A)	4.487 ksi 30.8 MN/m ²	13.94 ksi 96.3 MN/m ²
(B)	6.695 ksi 46.1 MN/m ²	20.10 ksi 138.5 MN/m ²
(C)	6.706 ksi 46.2 MN/m ²	20.03 ksi 138.0 MN/m ²
*(D)	7.076 ksi 48.7 MN/m ²	20.13 ksi 138.5 MN/m ²
*(E)	4.815 ksi 33.2 MN/m ²	13.94 ksi 96.3 MN/m ²

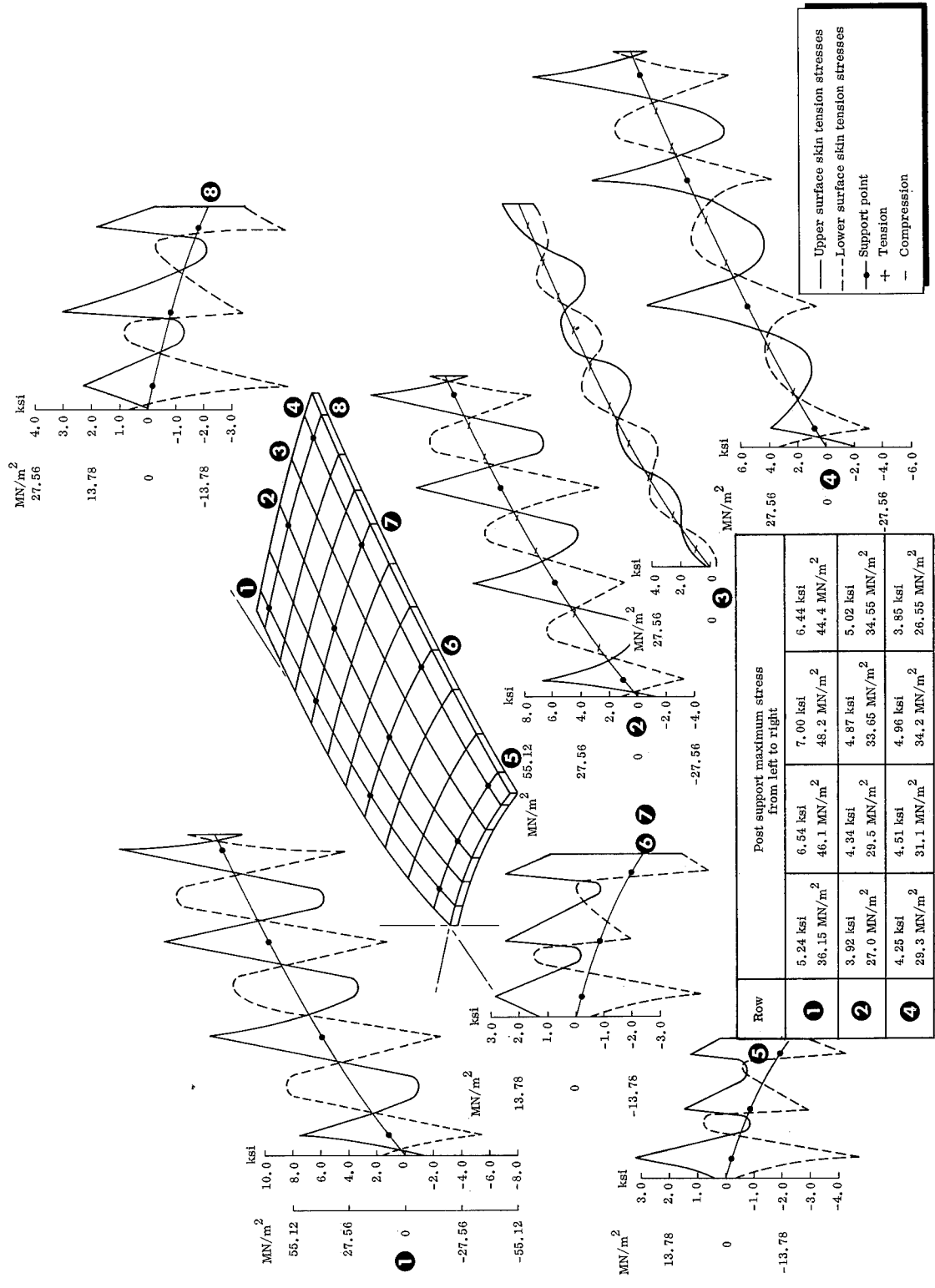

FIGURE 29. CROWN PANEL AIRLOAD PRESSURE STRESSES [PANEL SKIN TENSION AND POST SUPPORT STRESSES DUE TO NORMAL SURFACE PRESSURE LOAD OF 1.73 PSI (11.9 KN/M²) AT ROOM TEMPERATURE (CONDITION C-1, FIGURE 23)]

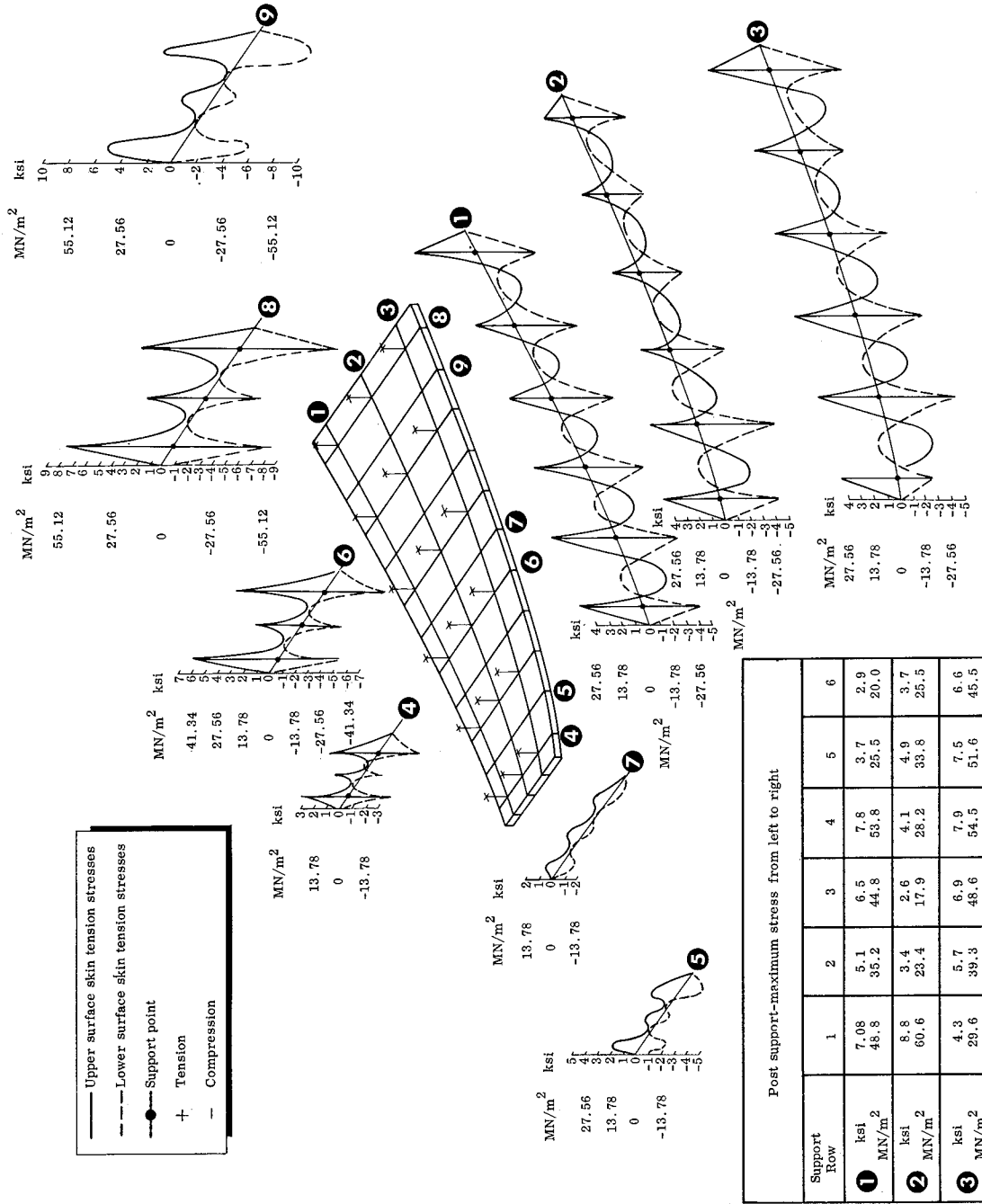

FIGURE 30. BOTTOM PANEL AIRLOAD PRESSURE STRESSES [PANEL SKIN TENSION AND POST SUPPORT STRESSES DUE TO NORMAL SURFACE PRESSURE LOAD OF 8.73 PSI (60.2 KN/M²) AT ROOM TEMPERATURE (CONDITION B-1, FIGURE 23)]

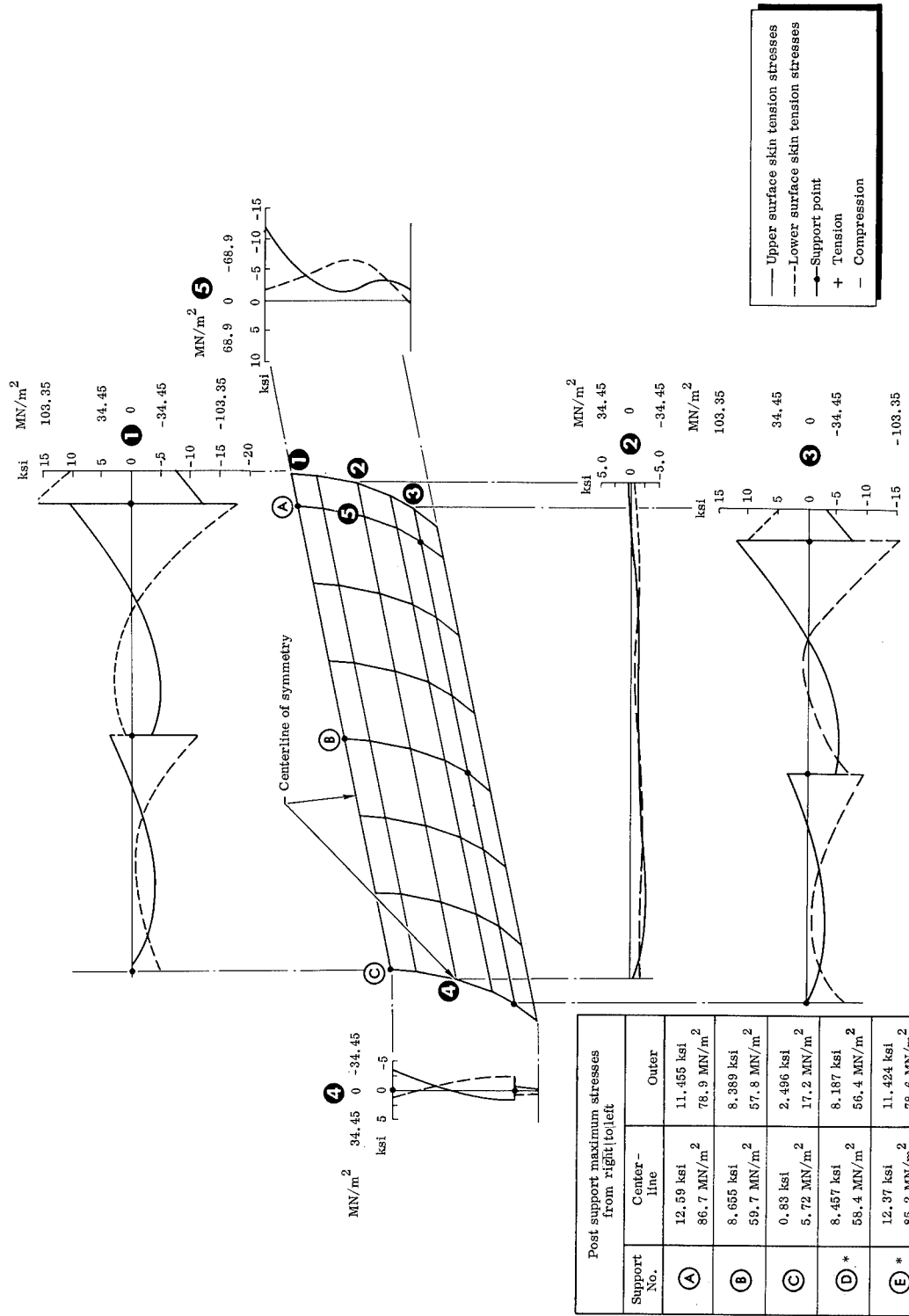

FIGURE 31. LEADING EDGE THERMAL STRESSES [PANEL SKIN TENSION AND POST SUPPORT STRESSES DUE TO CRITICAL THERMAL CONDITION (CONDITION L-2, FIGURE 23)]

*Appears in quadrant adjacent to left.

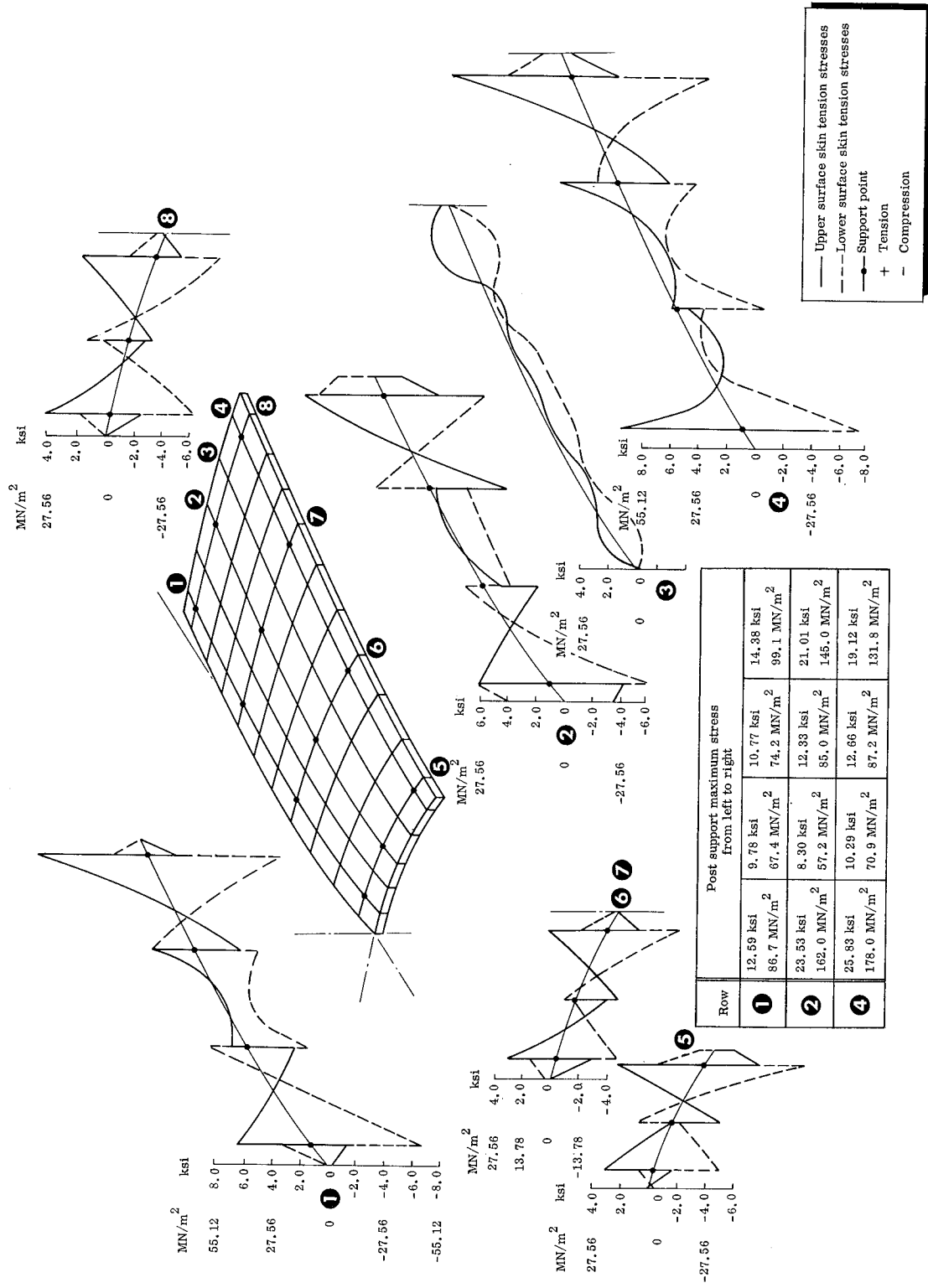
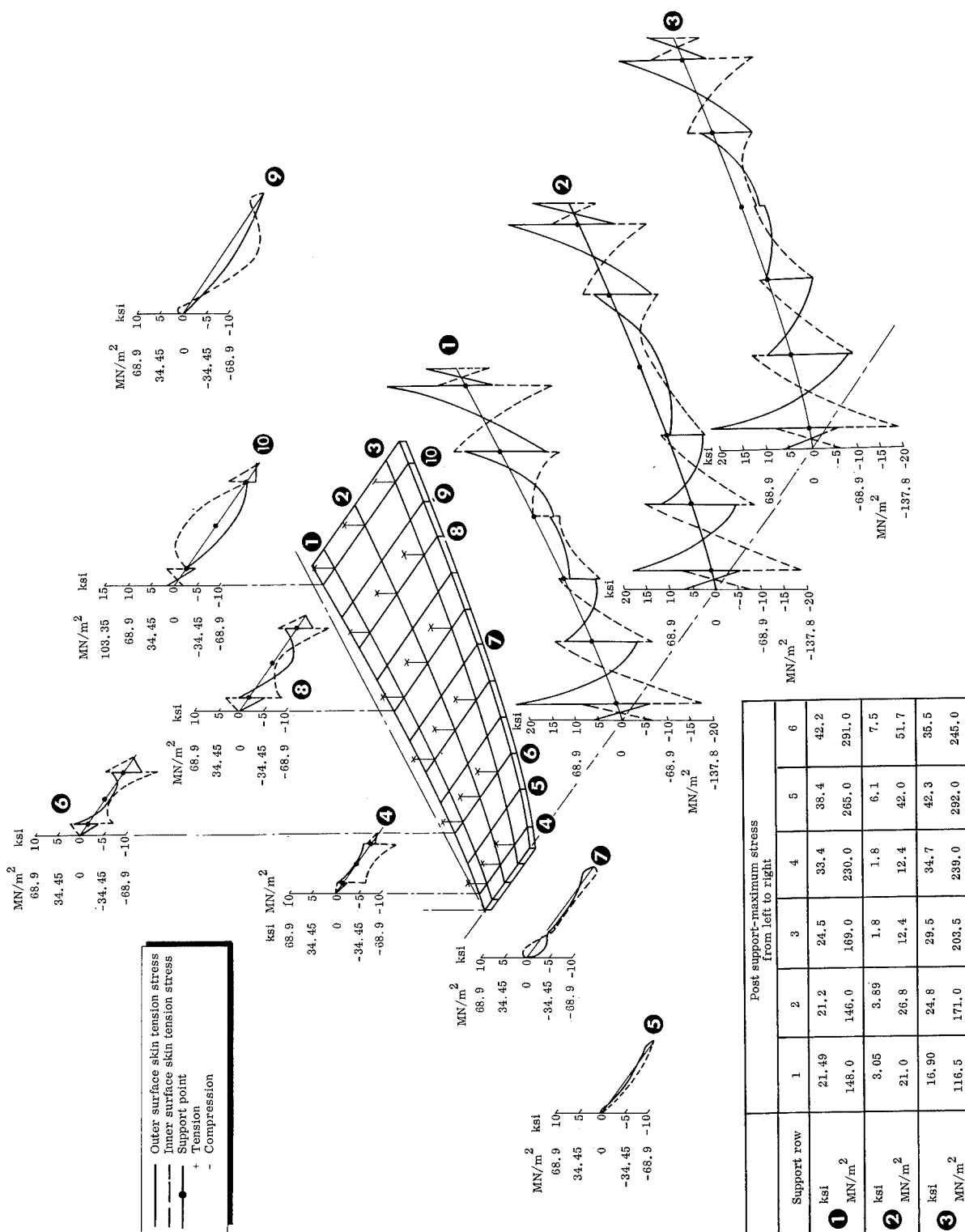

FIGURE 32. CROWN PANEL AIRLOAD THERMAL STRESSES [PANEL SKIN TENSION AND POST SUPPORT STRESSES DUE TO CRITICAL THERMAL CONDITION (CONDITION C-4, FIGURE 23)]



	Post support-maximum stress from left to right					
	1	2	3	4	5	6
Support row	1	2	3	4	5	6
ksi	21.49	21.2	24.5	33.4	38.4	42.2
1 MN/m ²	148.0	146.0	169.0	230.0	265.0	291.0
ksi	3.05	3.89	1.8	1.8	6.1	7.5
2 MN/m ²	21.0	26.8	12.4	12.4	42.0	51.7
ksi	16.90	24.8	29.5	34.7	42.3	35.5
3 MN/m ²	116.5	171.0	203.5	239.0	292.0	245.0

FIGURE 33. BOTTOM PANEL THERMAL STRESSES [PANEL SKIN TENSION AND POST SUPPORT STRESSES DUE TO CRITICAL THERMAL CONDITION (CONDITION B-3, FIGURE 23)]

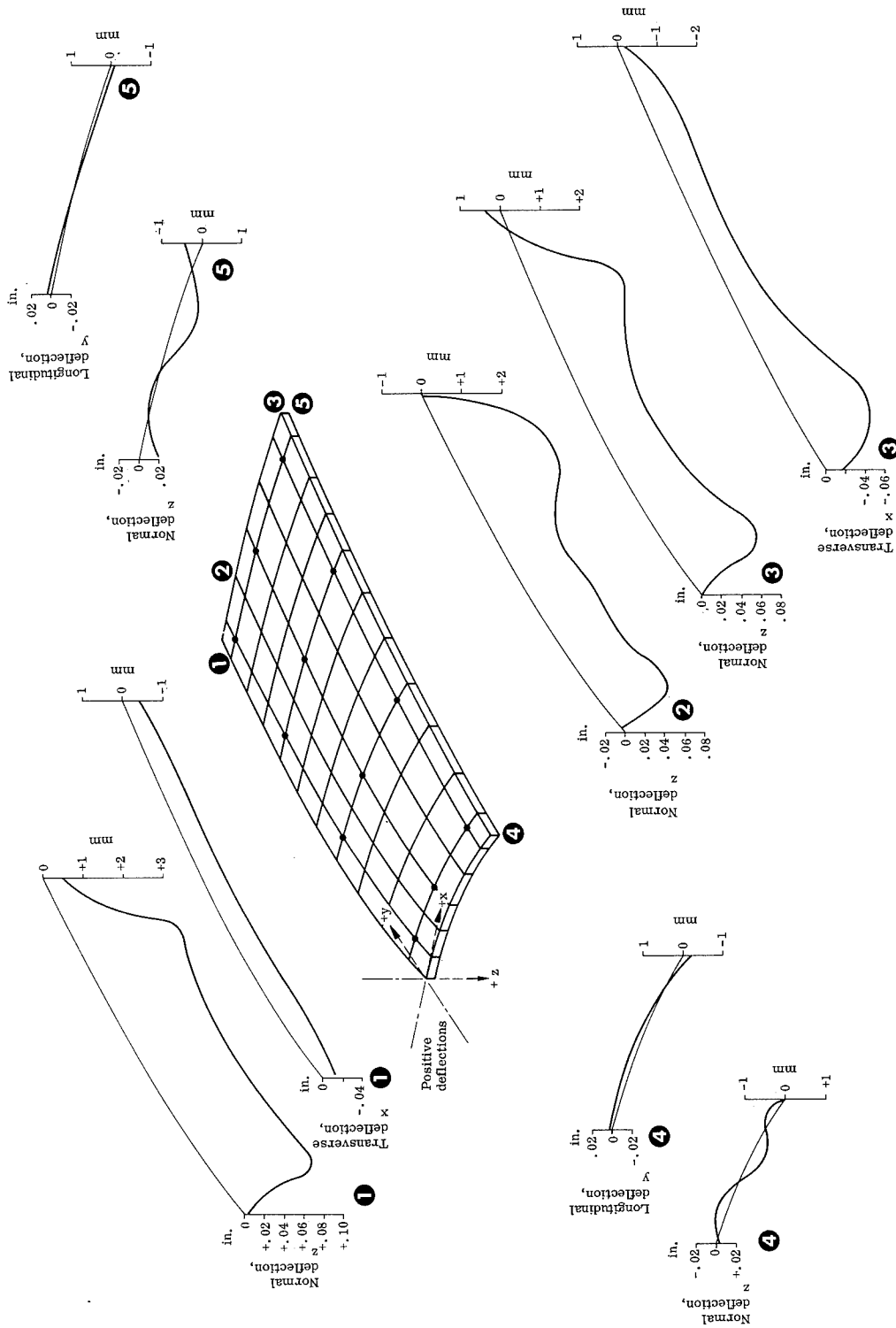

FIGURE 35. CROWN PANEL AIRLOAD PRESSURE DEFLECTIONS [CRITICAL PANEL DEFLECTIONS DUE TO NORMAL SURFACE PRESSURE LOAD OF 1.73 PSI (11.9 KN/M²) AT ROOM TEMPERATURE (CONDITION C-1, FIGURE 23)]

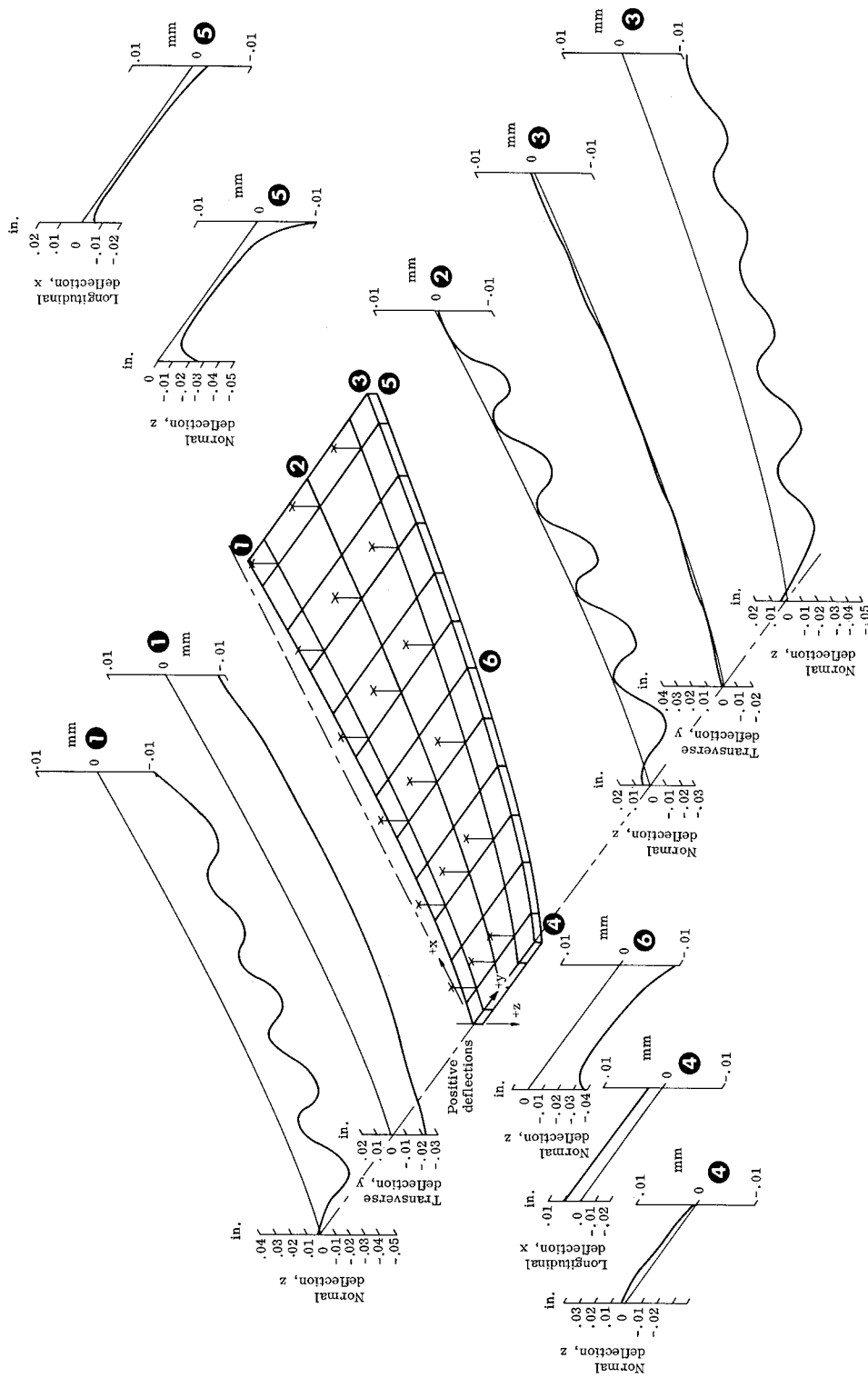

FIGURE 36. BOTTOM PANEL AIRLOAD PRESSURE DEFLECTIONS [PANEL DEFLECTIONS DUE TO NORMAL SURFACE PRESSURE LOAD OF 8.73 PSI (60.2 KN/M²) AT ROOM TEMPERATURE (CONDITION B-1, FIGURE 23)]

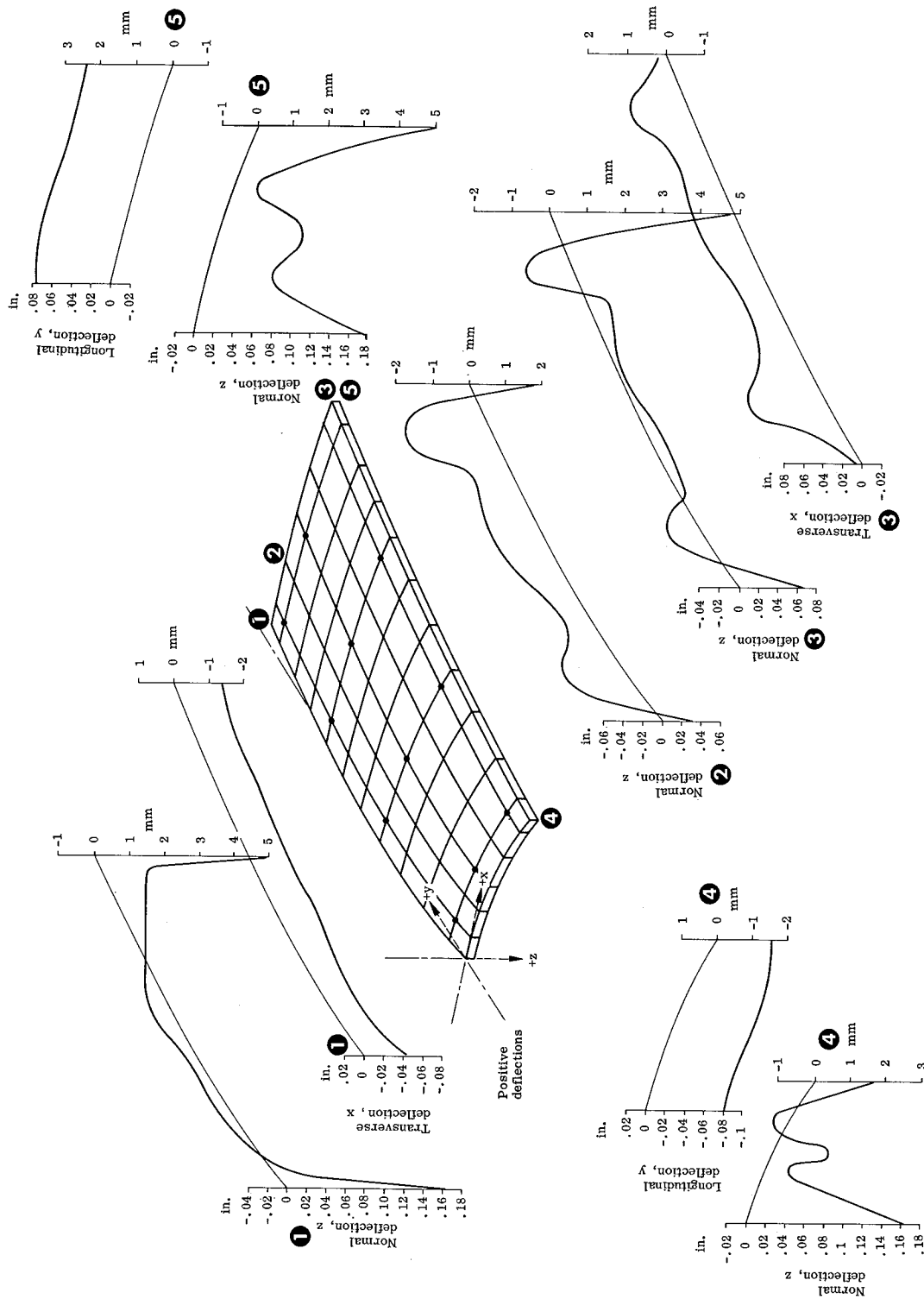

FIGURE 38. CROWN PANEL THERMAL DEFLECTIONS [CRITICAL PANEL DEFLECTIONS DUE TO THERMAL CONDITION (CONDITION C-4, FIGURE 23)]

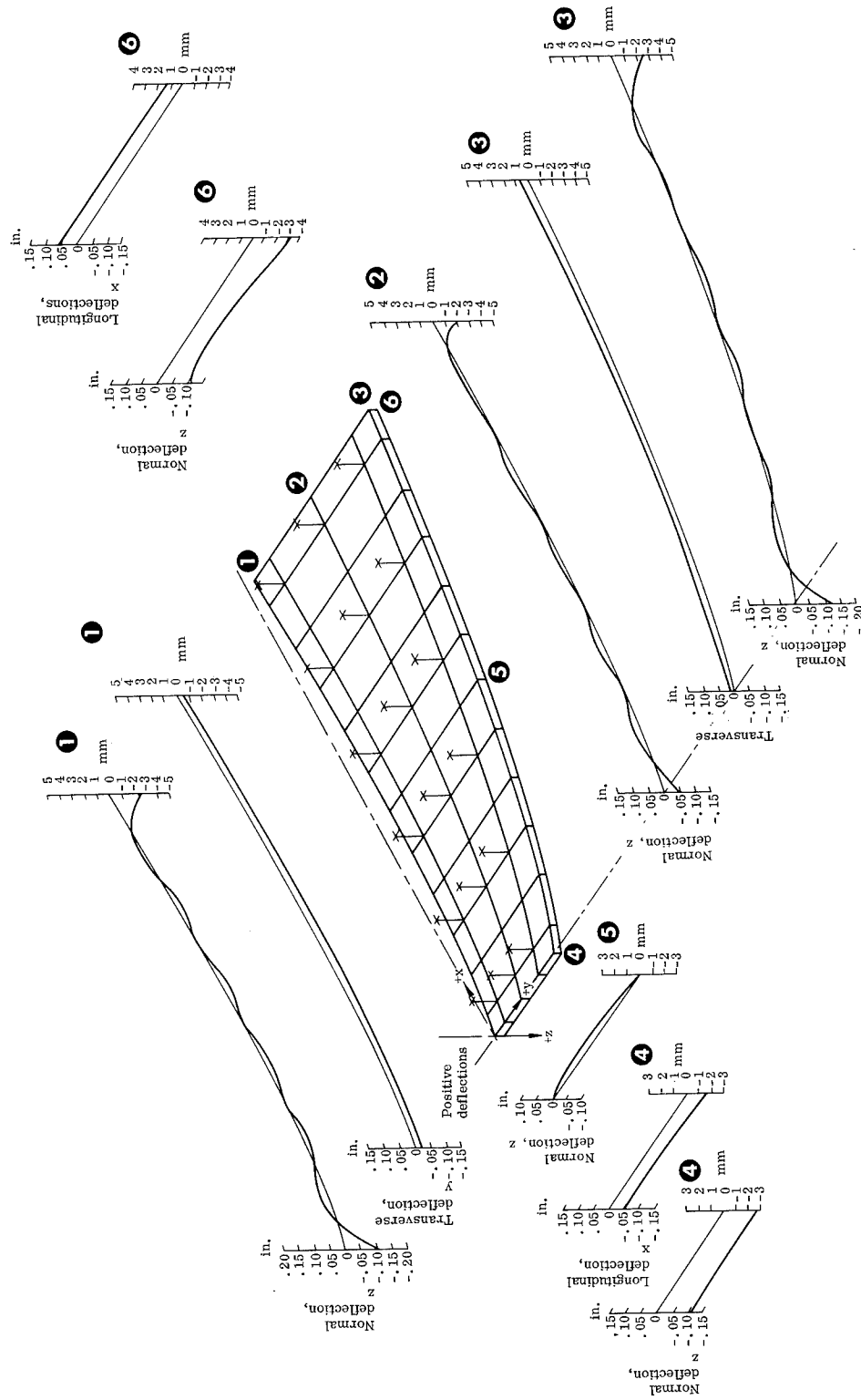

FIGURE 39. BOTTOM PANEL THERMAL DEFLECTIONS [PANEL DEFLECTIONS FOR CRITICAL THERMAL CONDITION (CONDITION B-3, FIGURE 23)]

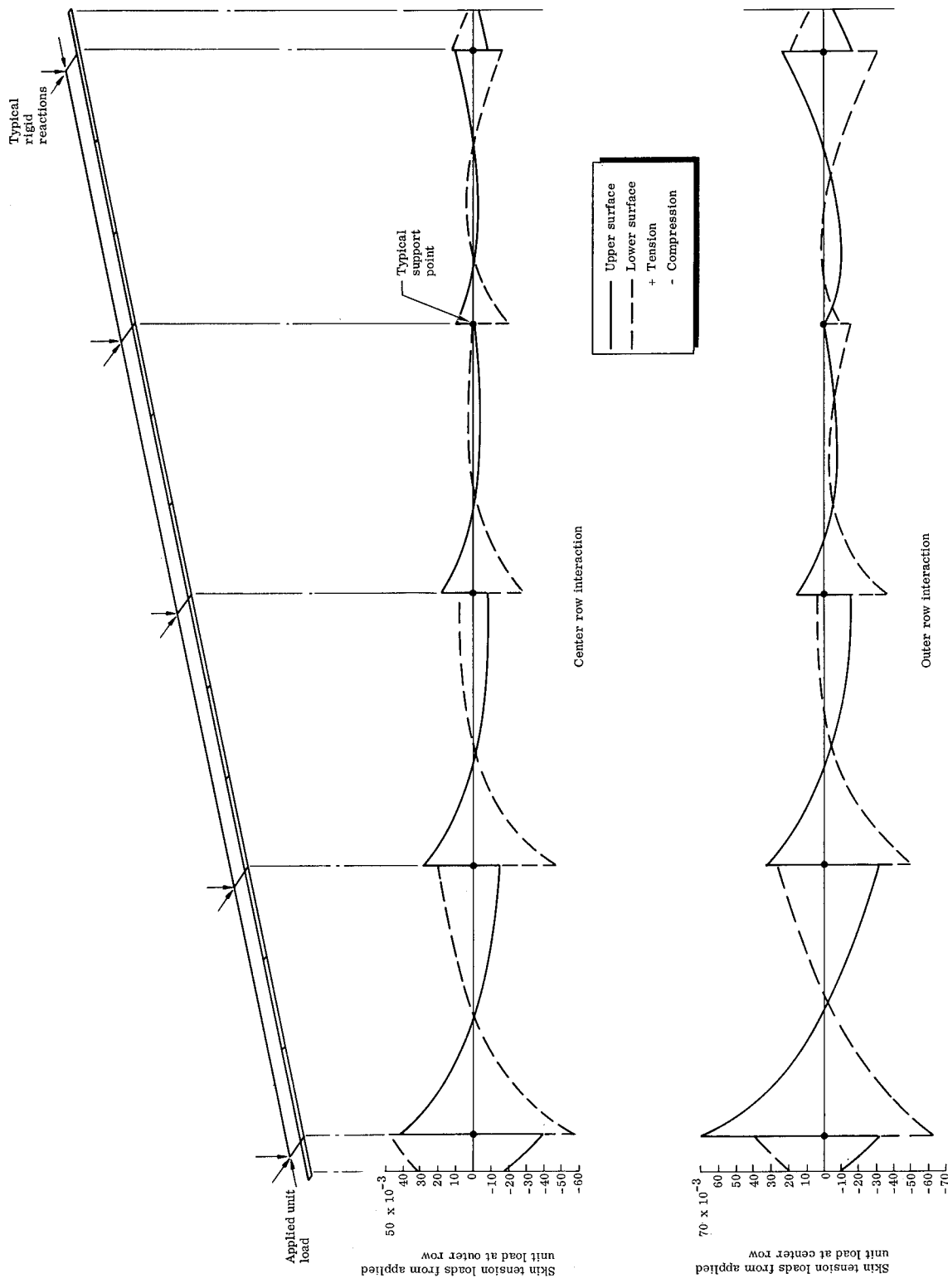

FIGURE 40. LEADING EDGE PANEL AND VEHICLE INTERACTION

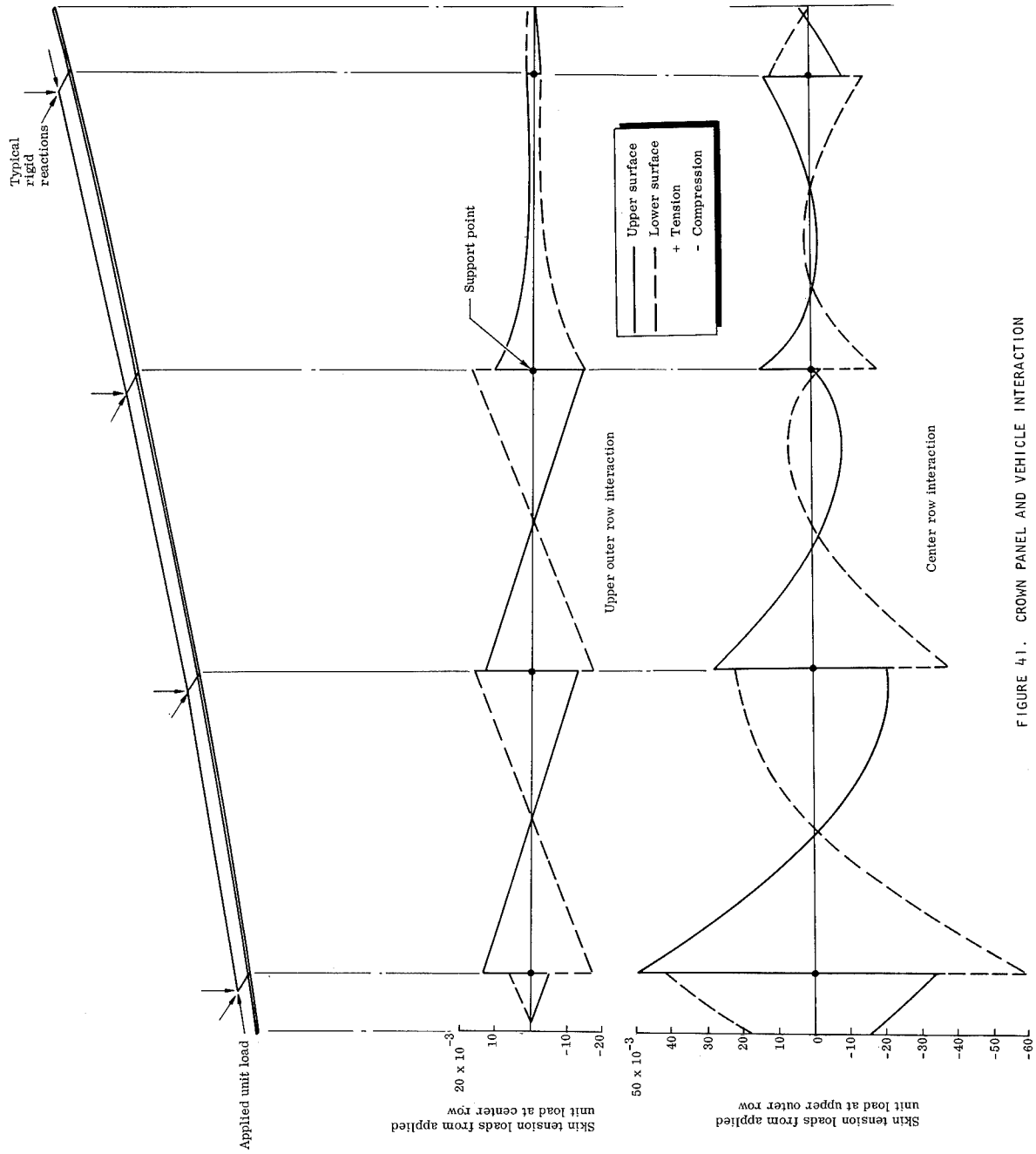

FIGURE 41. CROWN PANEL AND VEHICLE INTERACTION

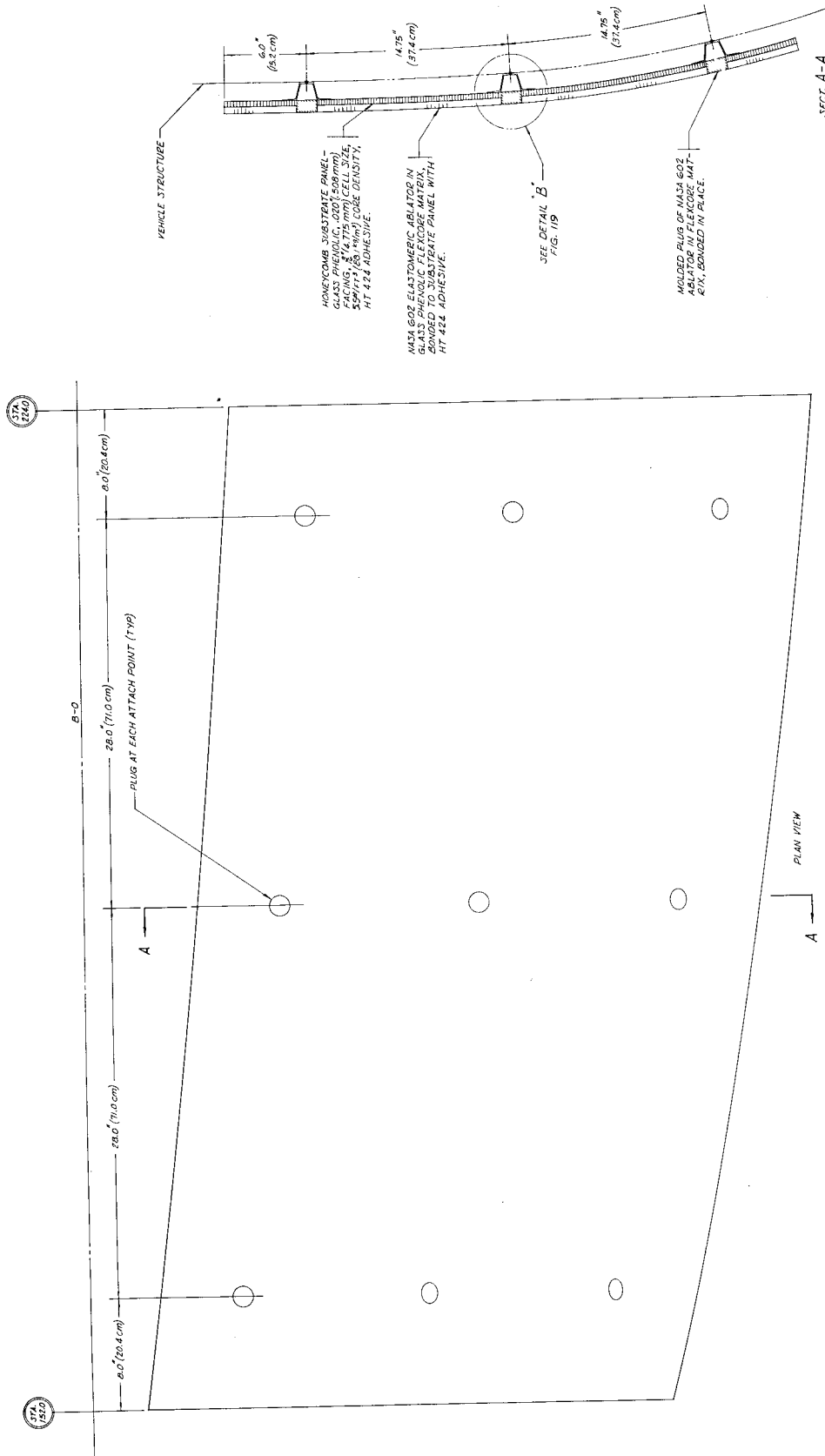

FIGURE 42. CROWN PANEL DRAWING

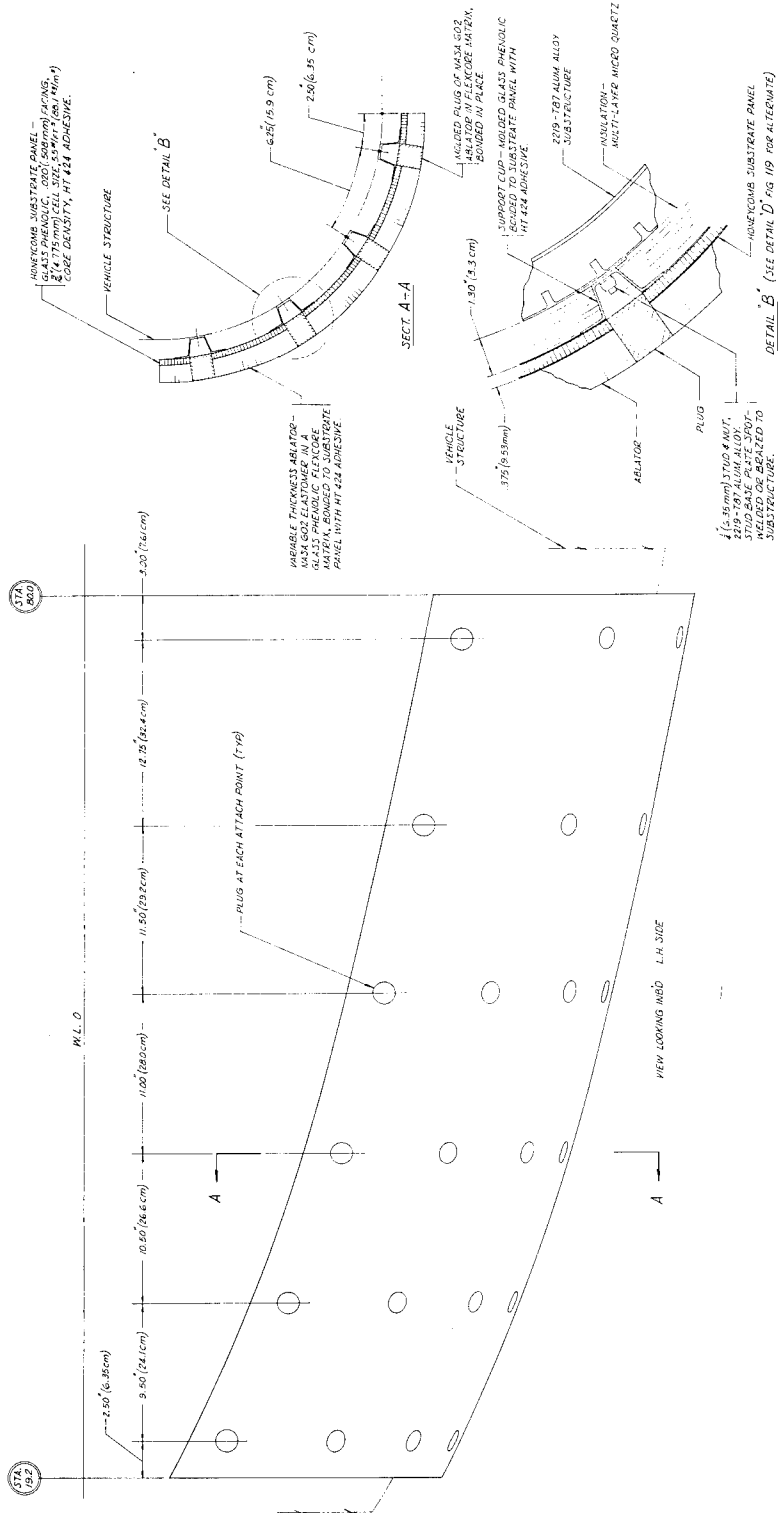

FIGURE 43. LEADING EDGE PANEL DRAWING