

REPORT DOCUMENTATION PAGE			Form Approved OMB No. 0704-0188	
Public reporting burden for this collection of information is estimated to average 1 hour per response, including the time for reviewing instructions, searching existing data sources, gathering and maintaining the data needed, and completing and reviewing the collection of information. Send comments regarding this burden estimate or any other aspect of this collection of information, including suggestions for reducing this burden, to Washington Headquarters Services, Directorate for Information Operations and Reports, 1215 Jefferson Davis Highway, Suite 1204, Arlington, VA 22202-4302, and to the Office of Management and Budget, Paperwork Reduction Project (0704-0188), Washington, DC 20503.				
1. AGENCY USE ONLY (Leave blank)		2. REPORT DATE 4/22/96	3. REPORT TYPE AND DATES COVERED Final Report (7/1/92-2/28/96)	
4. TITLE AND SUBTITLE Advanced Development of the Multi-Hundred Gigahertz Electro-Optic Modulator and Photodetector			5. FUNDING NUMBERS DAAL03-92-G-0294	
6. AUTHOR(S) John A. Nees, Assistant Research Scientist				
7. PERFORMING ORGANIZATION NAME(S) AND ADDRESS(ES) Center for Ultrafast Optical Science University of Michigan 1006 IST Bldg., 2200 Bonisteel Blvd. Ann Arbor, MI 48109-2099			8. PERFORMING ORGANIZATION REPORT NUMBER	
9. SPONSORING/MONITORING AGENCY NAME(S) AND ADDRESS(ES) U. S. Army Research Office P. O. Box 12211 Research Triangle Park, NC 27709-2211			10. SPONSORING/MONITORING AGENCY REPORT NUMBER  ARO 29939.5-EL-SDI	
11. SUPPLEMENTARY NOTES The view, opinions and/or findings contained in this report are those of the author(s) and should not be construed as an official Department of the Army position, policy, or decision, unless so designated by other documentation.				
12a. DISTRIBUTION/AVAILABILITY STATEMENT  Approved for public release; distribution unlimited.			12b. DISTRIBUTION CODE	
13. ABSTRACT (Maximum 200 words) The project was established to develop materials and structures for modulation and detection of multi-hundred-GHz signals. During the period of three years we have fabricated and tested modulators using bulk GaAs and Si overgrowth on GaAs. We have also developed a probe sensitive to greater than 100 GHz signals with 100 nm spatial resolution. This probe has since been extended to a minimum detectable voltage sensitivity of a few nanovolts per square root hertz. We made high-speed measurements of photoconductive response in Er:GaAs showing it to have a carrier lifetime varying from 22 ps to 3.1 ps with doping from $10^{19}/\text{cm}^3$ to $10^{20}/\text{cm}^3$ . Finally, we made photoconductive sweep-generating switches for jitter-free streak camera development.				
14. SUBJECT TERMS  ultrafast scanning-force microscope modulator probe Er:GaAs			15. NUMBER OF PAGES 12	
			16. PRICE CODE	
17. SECURITY CLASSIFICATION OF REPORT UNCLASSIFIED	18. SECURITY CLASSIFICATION UNCLASSIFIED	19. SECURITY CLASSIFICATION OF ABSTRACT UNCLASSIFIED	20. LIMITATION OF ABSTRACT UL	

19960524 164

Advanced Development of the Multi-Hundred GHz  
Electro-Optic Modulator and Photodetector

Final Report

April 1996

John A. Nees

Principal Investigator

Contract Number

DAAL 03-92-G-0294

**Abstract**

This project was established to develop materials and structures for modulation and detection of multi-hundred-GHz signals. During the period of three years we have fabricated and tested modulators using bulk GaAs and Si overgrowth on GaAs. We have also developed a probe sensitive to >100 GHz signals with 100 nm spatial resolution. This probe has since been extended to minimum detectable voltage sensitivity of a few nV/ $\sqrt{\text{Hz}}$ . We made high-speed measurements of photoconductive response in Er:GaAs showing it to have a carrier lifetime varying from 22 ps to 3.1 ps with doping from  $10^{19}/\text{cm}^3$  to  $10^{20}/\text{cm}^3$ . Finally we made photoconductive sweep-generating switches for jitter-free streak camera development.

## Introduction

Modern telecommunication technology utilizes only a small portion of the THz bandwidth available in optical fibers. One of the main restrictions on this bandwidth is the limitations present in the optoelectronic components used to modulate and detect signals in these systems. Likewise, many applications in the laboratory and in military equipment have need of high-speed modulation to deliver phased array signals or to provide ultrafast measurement capability. The development of high-speed electro-optic and optoelectronic measurement techniques allows us to investigate the materials and devices needed to accomplish modulation above 100 GHz. In this report we discuss the development of: a **multi-hundred GHz modulator**; a **photoconductive probe** with >100 GHz measurement bandwidth for interrogation of signals on both analog and digital devices with dimensions down to 100 nm; the testing of **Er:GaAs** for applications in high-speed testing and device isolation; and the modification of streak cameras to achieve **reduced jitter** and consequently to enhanced time resolution in the 100 GHz regime.

### Multi-hundred GHz modulator

An electro-optic (EO) modulator utilizes the Pockels effect to impose a phase shift on light passing through the device. Fundamentally this effect operates from dc into the visible regime where the polarizability of these materials gives rise to second harmonic generation (SHG). To first approximation the limitations of existing EO modulators are governed by the same criteria as the SHG process: velocity matching and attenuation. In this work we have sought to eliminate the phase mismatch between the optically guided wave in a GaAs modulator by placing a cover on the waveguide to slow the higher-speed electrical wave.[1] This approach has the added benefit that it strongly reduces dispersion of the electrical signal by providing more uniform boundary conditions for the propagating electrical wave. Attenuation has been addressed by incorporating high-conductivity electrodes.

In previous work a GaAs chip was placed in contact with a Au-inlaid coplanar strip (CPS) transmission line (TL). This resulted in excellent velocity matching and low attenuation.[2] The next step toward producing a working modulator was to solve the issues of producing a device which would not have to be hand-assembled with optical precision.

Waveguides were designed in GaAlAs/GaAs and both Au and Ti/W CPS TLs were defined and covered in low-temperature-grown GaAs (LT GaAs) by molecular beam epitaxy (MBE). Using a Ti Sapphire laser producing 120 fs pulses at 800 nm a subpicosecond-risetime signal was launched on the lines. The resulting waveform on the Ti/W modulator is shown in figure 1. The long risetime is indication that the high frequencies launched on the CPS were lost. The Au electrodes were of such poor quality that no measurement of high-speed signals was possible.

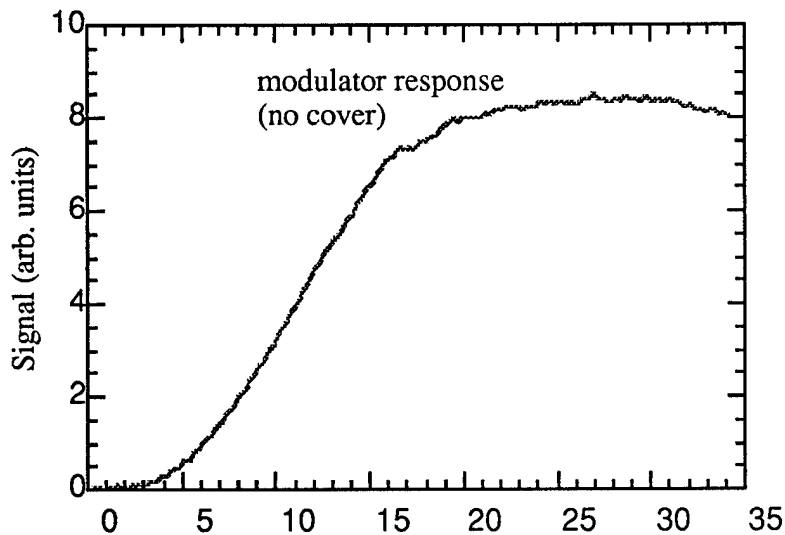

Figure 1 Impulse response of the GaAs/GaAlAs modulator as measured by the Ti:Sapphire/parametric oscillator combination. This risetime indicates the losses due to poor conductivity in the CPS TL.

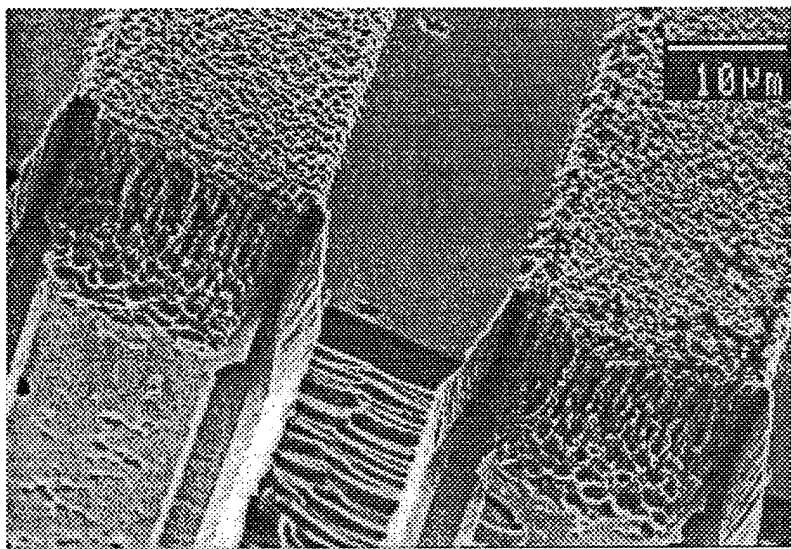

figure 2a Ti/W CPS TL after anneal at 600°C and RIE to expose. In this case the morphology of the metal is good, but the conductivity is still poor.

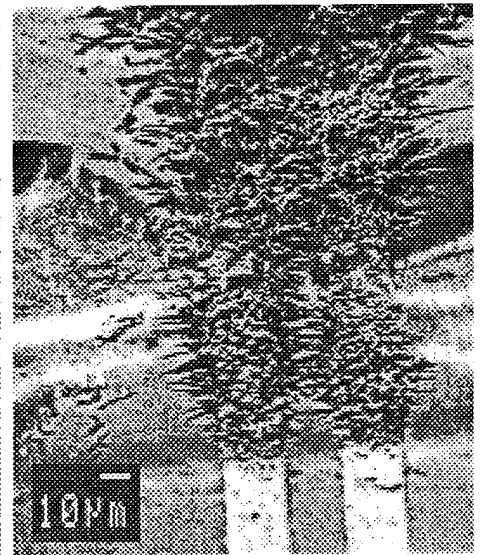

figure 2b SEM of Au CPS TL after overgrowth by LT GaAs and anneal at 600°C

Figures 2a-c show the morphology of the electrodes after the overgrowth process. Here it was discovered that the use of Au or Ti/W as electrodes produced a resistive CPS TL which could not carry a signal without excessive attenuation and that Au partially diffused into the GaAs during the post-overgrowth anneal. In figure 2a the Ti/Pt electrodes visible at the lower portion of the picture were exposed by reactive-ion etch (RIE) showing that the electrodes were not effected by the growth and annealing conditions. In figure 2b the Au electrodes having been covered by a shadow mask during the deposition process can be seen

extending beyond the growth region . The 200°C MBE overgrowth and 600°C anneal resulted in the diffusion of Au into the GaAs and the patterning shown if figure 2c.

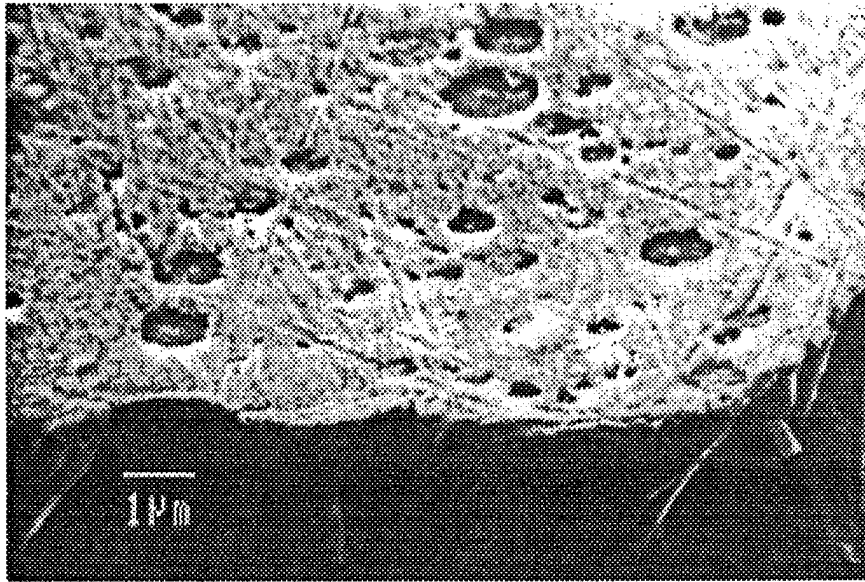

figure 2c. Close-up view of the Au after anneal at 600°C

Studies using a hot-plate to simulate the temperature conditions of the MBE growth chamber showed that the Au diffusion would not be sufficiently blocked by the Ti/Pt diffusion barrier. Two alternatives to that approach are illustrated in figure 3. The first is to use Mo to carry the electrical signal and continue to deposit a cover by MBE. The second alternative is to use a 'cold' process to deposit the cover.

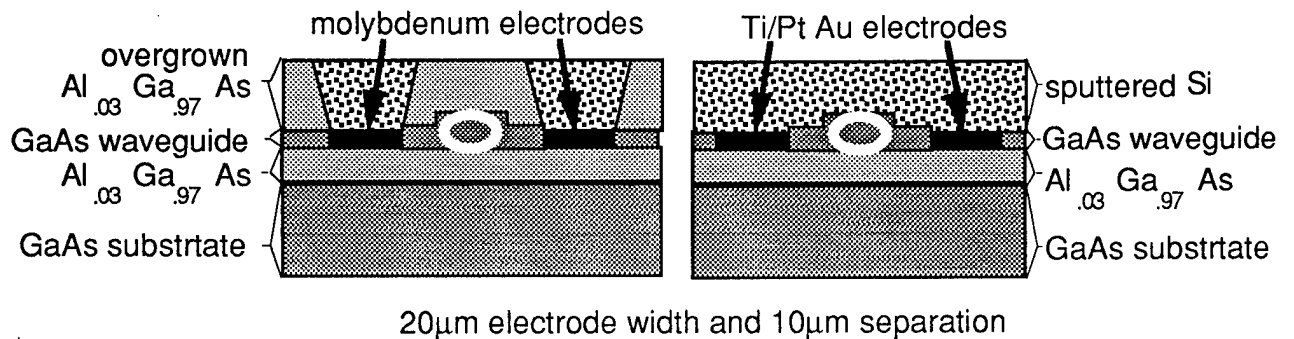

figure 3 Electrode materials for MBE overgrowth and for sputtered Si cover

Owing to the lower conductivity of Mo films a CPS design with electrodes 2-μm thick was chosen. RIE is used to form a trough to sink the electrodes in order to constrain the electric field to propagate chiefly in the waveguide region. Beside improving the overlap of the electrical and optical fields the counter-sinking of the electrodes also helps to reduce the portion of the electric field energy in the cover layer. This process results in CPS TLs with a resistance of 8 Ω/cm. Au lines with Ti/Pt diffusion barriers have been used in the alternative scheme to carry the electrical signal with minimal losses in the GaAs/GaAlAs modulators with a sputtered Si covers.

Free carriers in the GaAs and AlGaAs lead to two effects which can degrade the modulation strength. To avoid intrinsic carrier population in the waveguides an AlGaAs of very low Al fraction was used. Also, the MBE growth was done at a time when the growth chamber was estimated to be least contaminated by C impurities which introduce shallow traps in AlGaAs components. Attenuation of the electrical signal in the semiconductor materials results from ohmic losses due to free carriers in the region of the optical waveguide. Secondly, free carriers in the waveguide region can move to screen the modulating field. This can be true of both intrinsic carriers or optically induced carriers. To test the effects of optically induced carriers experiments were done with bulk high-resistivity GaAs modulators where the half-wave voltage of a modulator was measured at 1.06  $\mu\text{m}$ , 1.3  $\mu\text{m}$ , and 1.55  $\mu\text{m}$ . These values were 30% above the calculated value at 1.3 and 1.55  $\mu\text{m}$ , but at 1.06  $\mu\text{m}$  the half wave voltage could not be measured. The mobility of carriers in GaAs is such that the frequencies accessible to our lock-in amplifier were not capable of reducing the shielding effect of the photo-excited carriers. At 1.06  $\mu\text{m}$  we further attempted to freeze out carriers by going to liquid nitrogen temperature. This had no effect on the generation of carriers by the 1.06  $\mu\text{m}$  light, indicating the mid-gap absorption levels responsible for this absorption were not occupied predominantly by thermal excitation.

Modulators have now been fabricated with both Ti/W electrodes and Ti/Pt Au electrodes in waveguides with 3-4% Al. The Ti/Pt Au modulator has been covered with sputtered Si and tests are under way to determine the characteristics of the covered modulators.

### **Photoconductive probe**

The same Pockels effect which drives the process for modulation in the traveling-wave modulator has been used for a dozen years to measure signals on electronic circuits with THz bandwidth. By compromising this bandwidth we have been able to contribute to the achievement  $\text{nV}/\sqrt{\text{Hz}}$  minimum detectable voltage with probes that are also capable a nm spatial resolution. In conjunction with support from other funding sources we fabricated and tested a scanning force microscope probe with 2.5 picosecond temporal resolution and 100 nm spatial resolution. This is the first probe of its kind. Further work has developed detection electronics for this probe which, for the first time, allow photoconductive sampling through insulating layers.

The probe is based on low-temperature-grown GaAs (LT GaAs)[3-5]. To make the probe: a layer of AlGaAs with high Al fraction and of 0.5  $\mu\text{m}$  thickness is formed on GaAs by MBE; LT GaAs is then formed at about 220°C to a thickness of about 1  $\mu\text{m}$ ; The shape of the probe is defined by etching a patterned area through these layers to form a mesa of LT GaAs and AlGaAs: The GaAs substrates is then removed by lapping and etching, as in figure 4: And the probe is mounted on a support for operation as a scanning force probe or as a movable

sampling probe. Figure 5 shows a microscope picture of the tear-drop-shaped probe. This version of the probe was specifically designed to be supported by an optical fiber which would deliver gating light pulses and support the probe in the scanning microscope.

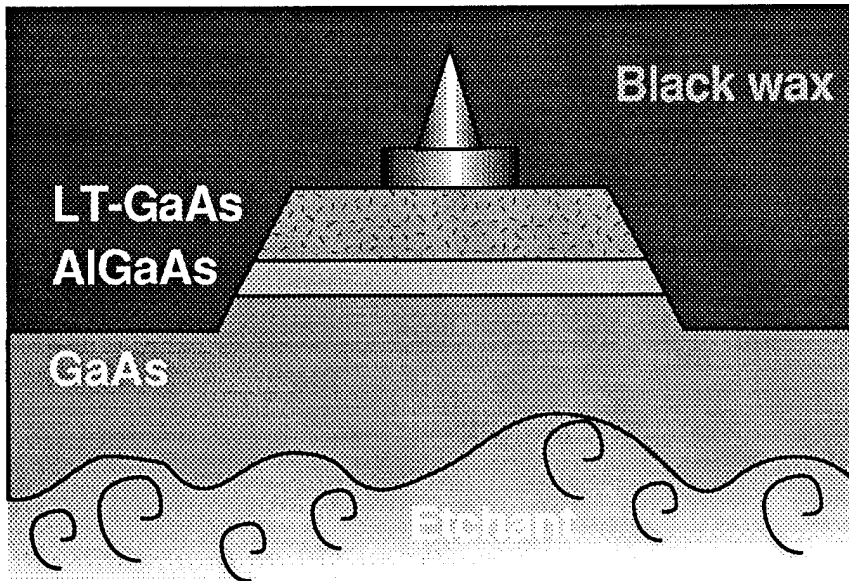

figure 4 Back-side etch procedure

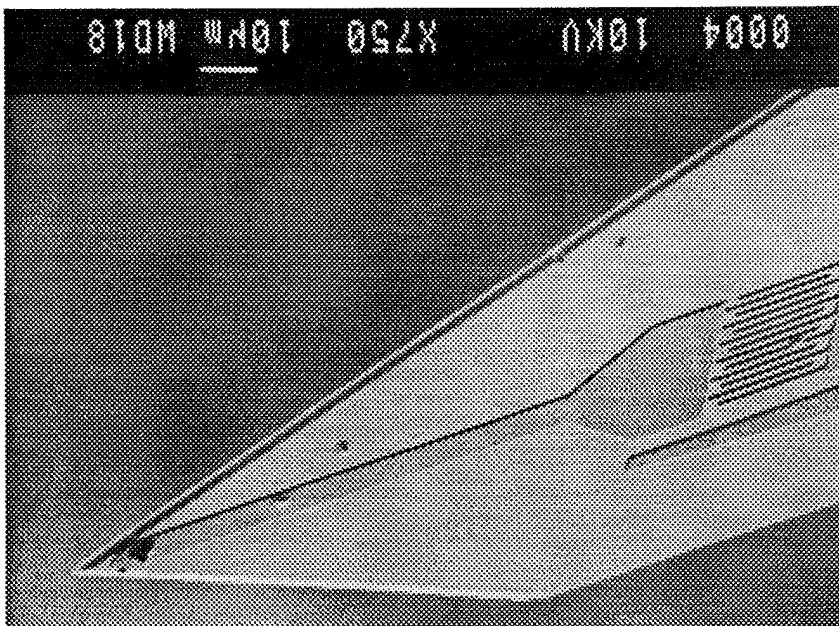

figure 5 Cantilever probe

The operation of the probe to measure both topography and electronic waveforms is shown in figure 6. The cw laser and quadrant detector are used in conjunction with a piezoelectric transducer to scan the surface of the device-under-test and to produce a 3-dimensional surface map. The probe is then placed in electrical communication with the desired measurement points and laser pulses activate the PC gate to acquire a time-resolved waveform. The control of the timing for the sampling operation is illustrated in figure 7, as is

the experimental set-up for determining the impulse response of the probe. Figure 8 shows the 2.5 ps response of the probe.

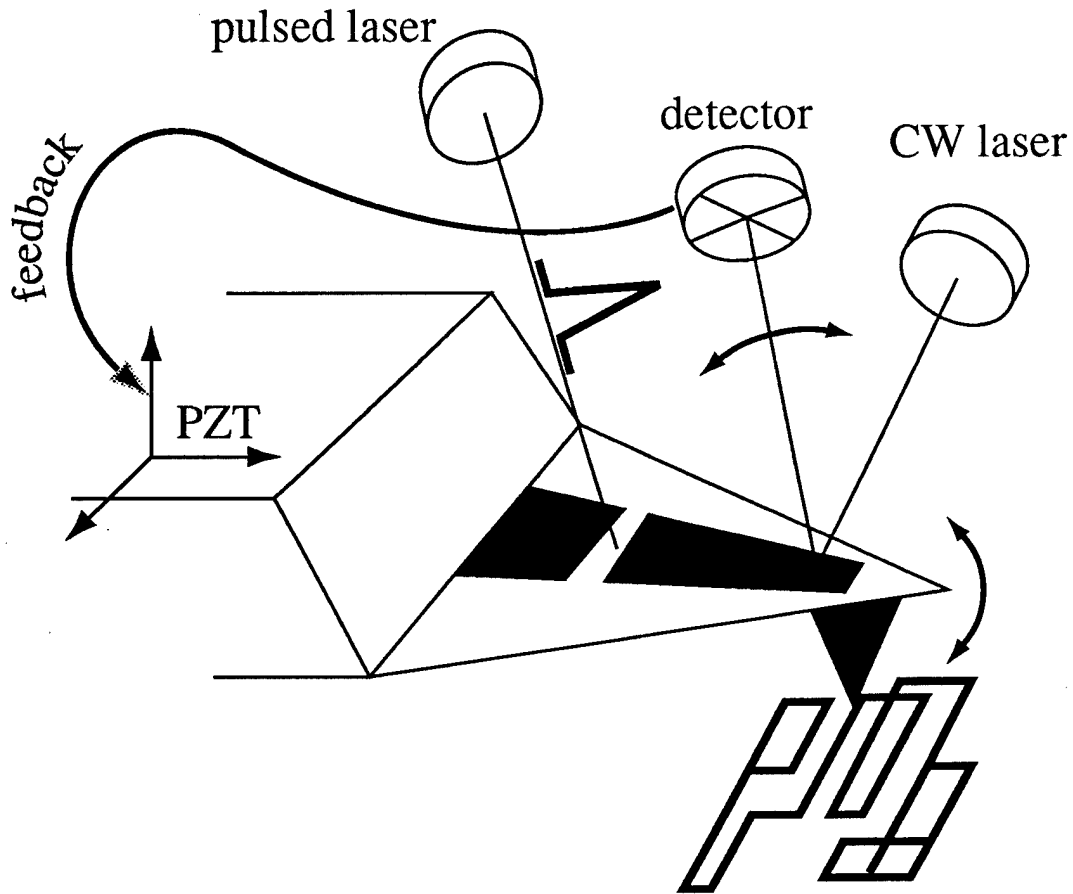

figure 6 Illustration of the PC probe in use as a scanning force microscope with waveform sampling capability

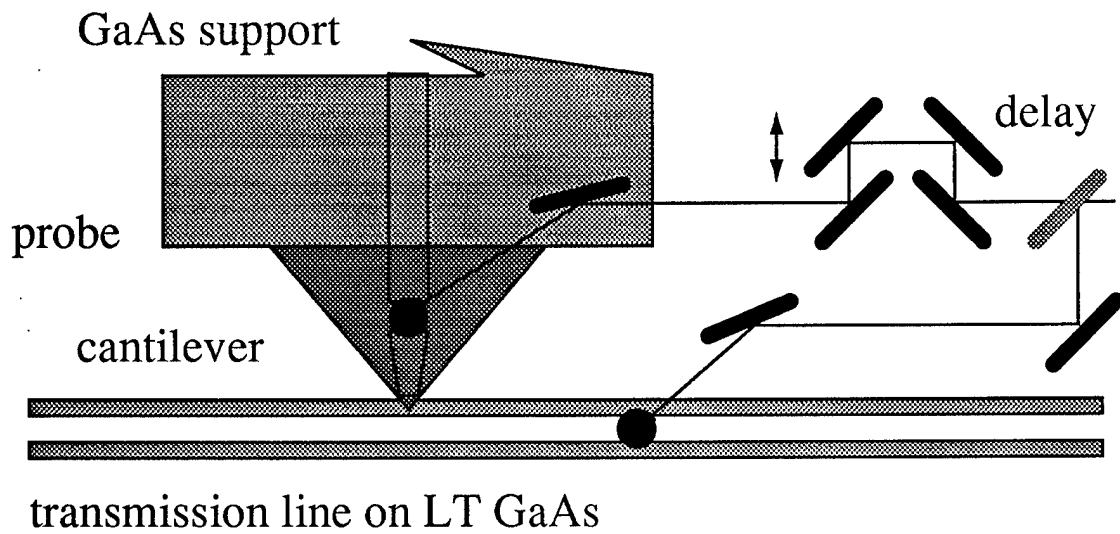

figure 7 Measurement of the impulse response of the probe

This work is a direct extension of the rigid probe work which its began as a 375 GHz photoconductive detector. We have also been contacted by an American company with an interest in this technology for VLSI testing.

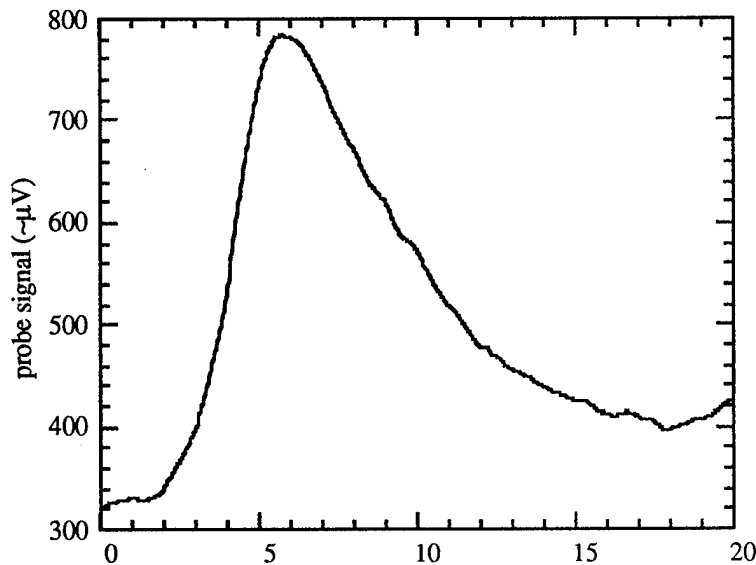

figure 8 Waveform acquired by LT GaAs probe with 100 fs laser pulses

This probe has utility not only for testing VLSI and ULSI circuits, but it is being applied also to launch and detect signals on devices from quantum wires to multi-chip modules. Intellectual property jointly discovered by one of our researchers and a visiting engineer from industry was secured in the form of a patent and discussions are opening the possibility of licensing for use in VLSI applications in the U.S.

### **Er:GaAs**

The complications and uncertainties associated with the properties of LT GaAs materials has been a concern in the manufacture of devices based on that technology. This has led us to seek alternative ways to achieve short time response in GaAs while not reducing the mobility of its carriers too greatly. In conjunction with the University Research Insensitive program in our department we were able to test the properties of Er:GaAs in the time domain. This laid some of the ground work for subsequent measurements on As implanted GaAs, a more promising candidate for picosecond response with high mobility. These measurements were made on an MBE layer of Er:GaAs [6, 7] with 10 μm (electrode width and inside separation) CPS TLs. Electron-beam lithography was used to define the electrodes with submicrometer interdigital switches for enhanced sensitivity. EO and photoconductive (PC) sampling provided time-resolved measurement of material response in terms of relative mobility and carrier lifetime. Table 1 relates the results of the EO sampling.

Er concentration	FWHM	Responsivity	Dark current
cm <sup>-3</sup>	ps	A/W	nA
10 <sup>18</sup>	22	1.4	3500
10 <sup>19</sup>	4.4	.026	7
6x10 <sup>19</sup>	3.3	.0005	24
10 <sup>20</sup>	3.1	.0005	110

Table 1

### Reduced jitter streak-camera measurements

Pulsed lasers have been used for years to study the response of a sample to a short excitation. The last few years have seen a rapid development of lasers producing ultra-short pulses of light energy in the subpicosecond range, opening the door to a new and vast field of research: ultrafast optical science.

The availability of the new ultrafast sources of energy to excite samples leads naturally to the need for corresponding ultrafast detection systems to study samples' response.

One such system is the streak camera based on a cathode ray tube: a photocathode converts photons to electrons which are accelerated, deflected and converted back to photons by a phosphor target.

The deflection voltage is in the form of a fast ramp resulting in a varying deflection as a function of time, so that different instants are mapped to different points on the phosphor target, these points being read by a CCD camera. Current time resolution is on the order of picoseconds.

Streak cameras on the market today suffer from a synchronization problem. The ramp is generated by an electronic circuit and even the state of the art leads to a time uncertainty (jitter), for single shot pulse measurement, on the order of tens of picoseconds. Time averaging of picosecond signals is thus impossible. The inability of streak cameras to adequately synchronize repetitive signals results in a severe loss of sensitivity and dynamic range in experiments. To fully exploit the potential possibilities of streak cameras, the problem of jitter has to be solved.

Since the streak camera would be used to measure the radiation emitted by a sample excited with an ultrashort laser pulse, one can, in principle, deviate a fraction of the excitation pulse energy and convert it into the ramp voltage used as time the base of the streak camera. This would remove any source of temporal uncertainty between the radiation being measured and the reference used to excite it. Because there would be no jitter, subsequent shots would be accumulated and signal/noise ratio increased many fold.

The key is in the conversion of a fraction of the energy contained in the excitation laser pulse into an electrical voltage ramp. This can be done by linear photoconductive switching and was published years ago by Dr. G. Mourou who demonstrated a low jitter free streak camera.[8]

More recently we have fabricated high-speed high-voltage PC switches using GaAs to give the necessary ramp for operation of a streak camera in synchronism with a short-pulse laser. This has resulted in the capability of averaging many sweeps with a resolution of about 4-ps (data is shown in figure 9). It should be noted that previous averaging experiments have either suffered from jitter of more than 20 ps or have been operated at repetition rates of nearly 100 MHz in synchroscan mode. The new result shows the promise for obtaining fine time resolution for laser systems operating with microjoule pulse energies and with pulse repetition rates from sub-Hz[9] to the high-kHz regime. The same high-voltage switch technology also has the potential to improve the temporal resolution of the streak camera into the subpicosecond regime.

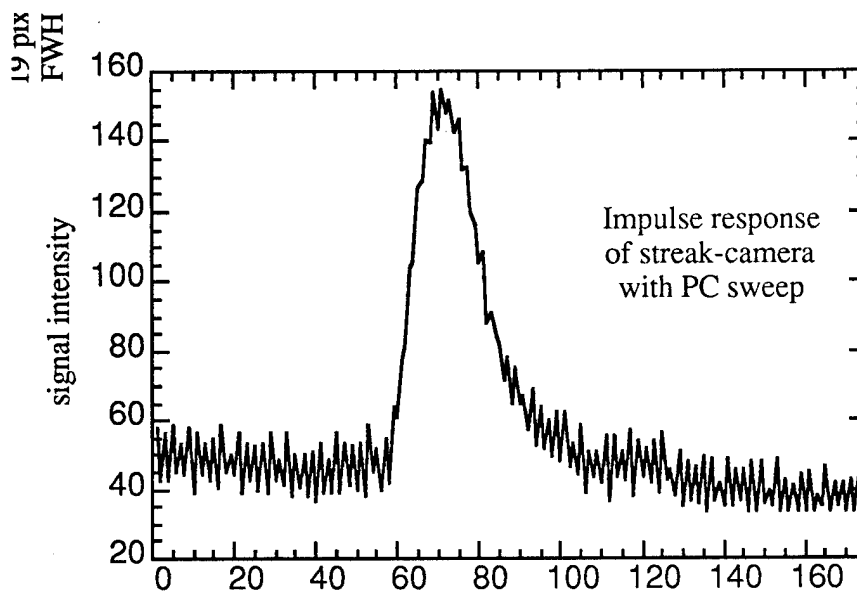

figure 9 Integrated signal using a PC switch to generate a jitter-free sweep in a streak-camera

## Summary of accomplishments

We have significant contributions to the state-of-the-art in four high-speed optoelectronic devices or systems.

### Modulator

- Procedures for fabrication of high conductivity electrodes were developed.

### Probe

- 100 nm spatial resolution was combined with 2.5 picosecond temporal resolution in a sensitive new probe.

### Er:GaAs

- Measurements of responsivity and lifetime were made to establish the working parameters for Er:GaAs.

### Streak-camera

- High-voltage switches were made to enable low-jitter measurements of weak optical signals

## References

1. J. Nees, S. Williamson, and G. Mourou, *Appl. Phys. Lett.*, 54, 1962, (1989).
2. Y. Chen, J. Nees, S. Williamson, Picosecond Electronics and Optoelectronics, OSA Proceedings on Ultrafast *Electronics and Optoelectronics 9*, eds. T.C.L.G. Sollner, J. Shah, 46 (1991).
3. Nees, S. Wakana, and C.-Y. Chen, *Ultrafast Phenomena IX*, eds., P.F. Barbara, W.H. Knox, G. A. Mourou, A.H. Zewail, Springer-Verlag Berlin Heidelberg 139 (1994).
4. J. Kim, J. Son, S. Wakana, J. Nees, S. Williamson, J. Whitaker, and G. A. Mourou, OSA Proceedings on Ultrafast *Electronics and Optoelectronics 14*, eds. J. Shaw, U. Mishra (1993) 224.
5. J. Nees, S. Wakana, S. Hama, to be published in July, 1996, in *Optical and Quantum Electronics*.
6. S. Gupta, S. Sethi, and P.K. Bhattacharya, *Appl. Phys Lett.*, (62) 1128, (1993).
7. S. Sethi, T. Brock, P.K. Bhattacharya, J. Kim S. Williamson, D. Craig, and J. Nees, *Electr. Device Lett.*, (16) 3, 106 (1995).
8. G. Mourou, W. Knox, *Appl. Phys. Lett.* 36, 623 (1980).
9. A. Maksimchuk, M. Kim, J. Workman, G. Korn, J. Squier, D. Du, D. Umstadter, and G. Mourou, M. Bouvier, *Rev. Sci. Instrum.* 67(3) (March 1996).

**Graduate Student Supported:** Douglas L. Craig

**Publications:**

J. Nees, S. Wakana, and C.-Y. Chen, *Ultrafast Phenomena IX*, eds., P.F. Barbara, W.H. Knox, G. A. Mourou, A.H. Zewail, Springer-Verlag Berlin Heidelberg 139 (1994).

J. Kim, J. Son, S. Wakana, J. Nees, S. Williamson, J. Whitaker, and G. A. Mourou, OSA Proceedings on Ultrafast *Electronics and Optoelectronics* 14, eds. J. Shaw, U. Mishra (1993) 224.

J. Nees, S. Wakana, S. Hama, to be published in July, 1996, in *Optical and Quantum Electronics*.

**Patents Granted:** J. Nees, S. Wakana, "Ultrafast Electrical Scanning Force Microscope Probe" #5 442 300, August 15 1995.