

REPORT DOCUMENTATION PAGE			Form Approved OMB NO. 0704-0188	
Public reporting burden for this collection of information is estimated to average 1 hour per response, including the time for reviewing instructions, searching existing data sources, gathering and maintaining the data needed, and completing and reviewing the collection of information. Send comment regarding this burden estimate or any other aspect of this collection of information, including suggestions for reducing this burden, to Washington Headquarters Services, Directorate for Information Operations and Reports, 1215 Jefferson Davis Highway, Suite 1204, Arlington, VA 22202-4302, and to the Office of Management and Budget, Paperwork Reduction Project (0704-0188), Washington, DC 20503.				
1. AGENCY USE ONLY (Leave blank)	2. REPORT DATE 05/24/96	3. REPORT TYPE AND DATES COVERED 05/01/95 - 04/30/96		
4. TITLE AND SUBTITLE Research in Fiber Based Raman and Brillouin Active Devices for Optical Communication, Computing and Sensing			5. FUNDING NUMBERS DAAH04-95-1-0197	
6. AUTHOR(S) Chung Yu				
7. PERFORMING ORGANIZATION NAME(S) AND ADDRESS(ES) North Carolina A & T State University, Greensboro, NC 27411			8. PERFORMING ORGANIZATION REPORT NUMBER	
9. SPONSORING / MONITORING AGENCY NAME(S) AND ADDRESS(ES) U.S. Army Research Office P.O. Box 12211 Research Triangle Park, NC 27709-2211			19960607 101	
11. SUPPLEMENTARY NOTES The views, opinions and/or findings contained in this report are those of the author(s) and should not be construed as an official Department of the Army position, policy or decision, unless so designated by other documentation.				
12a. DISTRIBUTION / AVAILABILITY STATEMENT Approved for public release; distribution unlimited.			12 b. DISTRIBUTION CODE	
13. ABSTRACT (Maximum 200 words) It has been discovered in our experiments in this reporting period, that the fibers we have been studying are coated, though unjacketed. This coating acts to broaden the mode widths in the GAWBS spectrum. To verify the effect due to the coating, the fibers in our stock must be stripped of their coating. We were successful in producing bare fibers up to 25m chemically. A series of experiments were performed to compare the bare fiber GAWBS spectrum with the coated fiber spectrum. Their significant difference in mode linewidth has practical structural sensing applications. DTIC QUALITY INSPECTED 3				
14. SUBJECT TERMS Student Sensor Research			15. NUMBER OF PAGES 1	
			16. PRICE CODE	
17. SECURITY CLASSIFICATION OR REPORT UNCLASSIFIED	18. SECURITY CLASSIFICATION OF THIS PAGE UNCLASSIFIED	19. SECURITY CLASSIFICATION OF ABSTRACT UNCLASSIFIED	20. LIMITATION OF ABSTRACT UL	

DISCLAIMER NOTICE

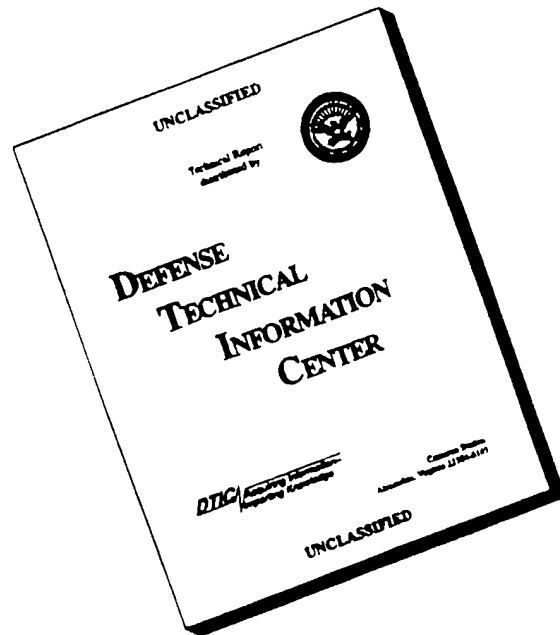

THIS DOCUMENT IS BEST QUALITY AVAILABLE. THE COPY FURNISHED TO DTIC CONTAINED A SIGNIFICANT NUMBER OF PAGES WHICH DO NOT REPRODUCE LEGIBLY.

Research in Fiber based Raman and Brillouin Active Devices for optical
Communication, Computing as Sensing

Army Research Office Grants:

DAAH04-95-1-0197

05/01/95 - 04/30/96

By

Chung Yu

Department of Electrical Engineering
North Carolina A & T State university
Greensboro, NC 27411

Most the work in this reporting period has been in the area of exploiting the GAWBS spectrum in single-mode fibers as the sensing mechanism for structural integrity. The accumulated data from the past several years have been repeatedly confirmed experimentally and theoretically. The depolarized GAWBS spectrum is attributed to TR_{2m} modes thermally excited in the fiber, that scatter laser light coherently. The mode spectral width has so far been taken to be sufficiently narrow, as to represent the theoretically predicted for bare (the “so called” unjacketed) fibers.

It has only been recently discovered in our experiments and compared with reported work by others, that the fibers we have been studying are coated, though unjacketed. This coating acts to broaden the mode widths in the GAWBS spectrum. To verify the effect due to the coating, the fibers in our stock must be stripped of their coating. Our first attempt was to mechanically strip the fiber with a mode stripper device. We were successful in producing a 2.5m long bare fiber, after numerous attempts with many fiber breakages. A series of experiments were performed to compare the bare fiber GAWBS spectrum with the coated fiber spectrum. Consistent results were obtained and presented below for comparison. (Fig.1, a, b)

Experiment I

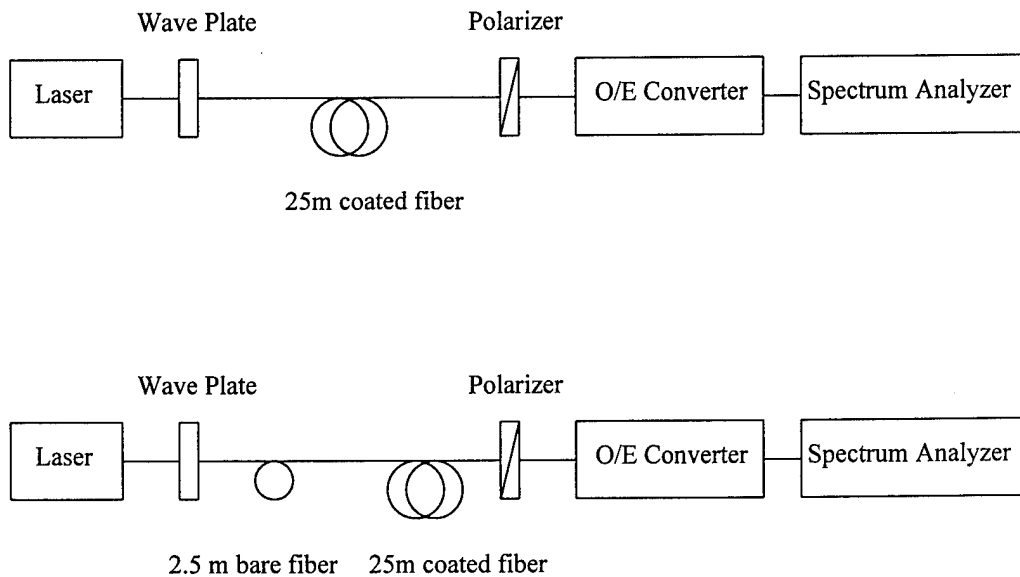

*Note: coated fiber and bare fiber are of different material.

Figure 1. a Experiment Setup

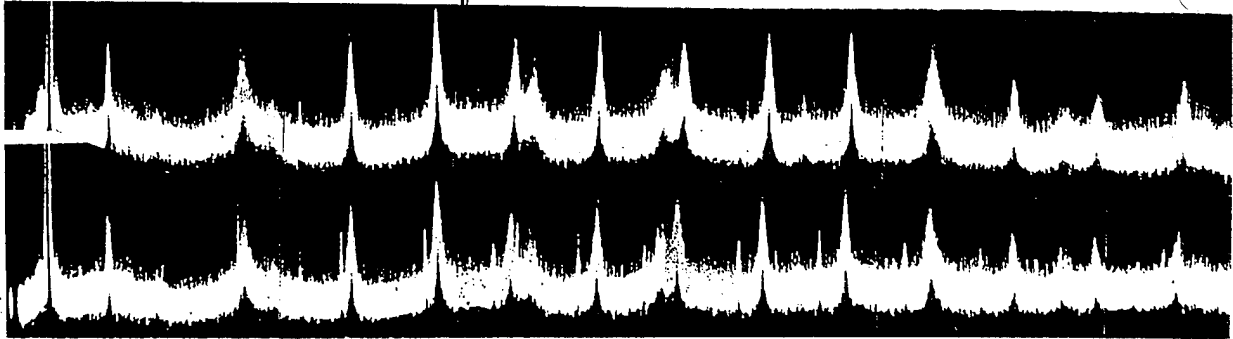

Upper Trace; 25m coated fiber
Lower Trace: 25m coated fiber + 2.5m bare fiber
Notice: much narrower mode peaks were introduced by bare fiber

Figure 1. b GAWBS spectrum of coated and bare fibers

By chance the two fibers are of different material. From our previous studies, their GAWBS spectrum should be shifted with respect to each other. Such a shift exposes the fiber modes of the bare fiber, as seen in Fig.1. b. This finding is of great practical significance, since we can tailor the sensing system such that the bare fiber would be embedded in a composite structural component, while laser power is fed from a jacketed fiber of different chemical composition. The bare fiber could then use the composite as coating or jacket with broadened GAWBS mode peaks. Any delamination in the composite could, presumably, free the bare fiber from the composite “jacket”, leading to finer GAWBS modes. Such a change in mode linewidth could be an indicator of composite materials damage or delamination.

Experiment II

To better understand the bare fiber GAWBS spectrum, the 2.5m fiber was connected directly to the laser and detection system with minimum fiber lead (8.4m). (see Fig. 2.a) It was anticipated that the sharper bare fiber modes would emerge above the broader and noisier fiber lead GAWBS spectrum. This proved to be true. (Fig. 2. b, upper trace)

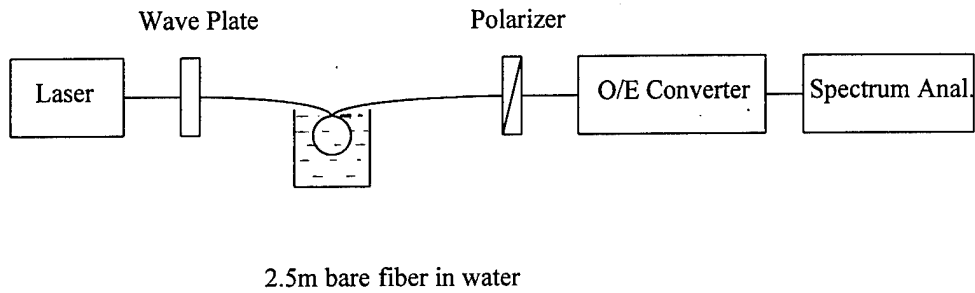
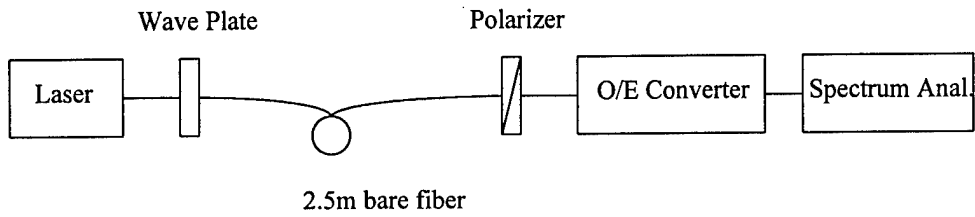
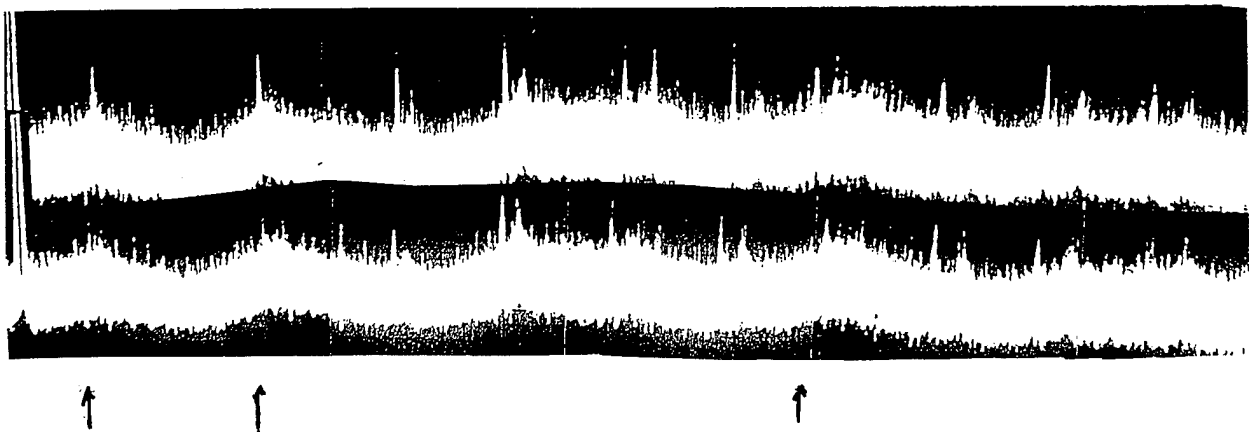

Figure 2. a Experiment Setup



Upper Trace: 2.5m bare fiber in air. Fiber lead: 8.4m
 Lower Trace: 2.5m bare fiber in water. (mode peaks 1, 2, 3 missing)

Figure 2. b Bare fiber GAWBS spectrum in air and in water

Figure 2. b, lower trace was taken with the 2.5m bare fiber immersed in water. The purpose of this exercise was to assess the sensitivity of the bare fiber GAWBS mode structure to a damping environment. It was quite evident that the mode structure was affected, as 3 mode peaks disappeared (indicated by arrows).

Experiment III

Our curiosity was so heightened that a longer bare fiber was sought to better assess this phenomenon. The fiber manufacturer was approached and apparently, the coating could be removed chemically with a compound called Zip-Strip. We were able to strip the coating of a 25m long fiber.

To see the effect directly, the coated fiber was first observed for its GAWBS spectrum (upper trace Fig. 3) in a basin. The gelatinous Zip-Strip compound was poured over the fiber in the basin. According to instruction, after waiting several seconds, alcohol was added to neutralize Zip-Strip. The GAWBS spectrum was monitored continuously. It was rather dramatic that the GAWBS spectrum sharpened almost instantly, especially among the higher order modes, as indicated in Fig.3 (lower trace) by increased mode amplitudes. The coating was easily separated from the fiber.

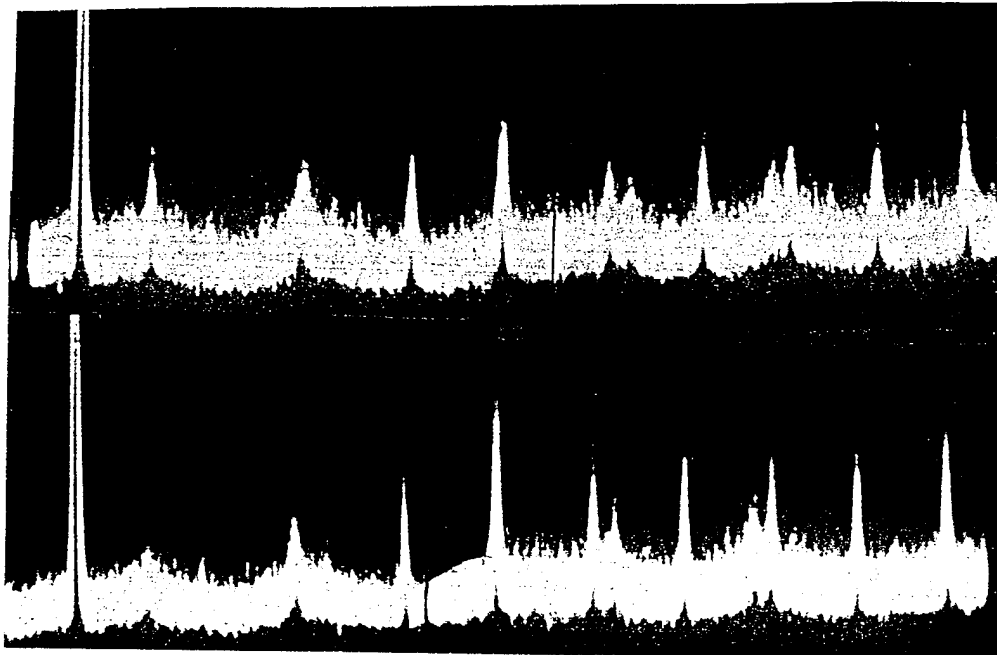

Upper Trace: coated 25m long fiber
Lower Trace: 25m long fiber after coating was removed chemically

Figure 3 GAWBS spectrum of coated and uncoated fiber

PRELIMINARY CONCLUSIONS

1. Bare fiber GAWBS spectrum mode linewidth is noticeably narrower than coated fiber GAWBS mode linewidth.
2. Narrowing of the mode linewidth leads to increase in mode amplitude.
3. A 2.5 m bare fiber has GAWBS mode linewidths narrower than 25 m bare fiber mode linewidths. This may be due to the noise nature of the GAWBS spectrum, which increases with fiber length, as previously reported.
4. Bare fiber when embedded in composites may be considered to be coated fiber with the composite serving as coating or jacket. The GAWBS spectrum of the fiber should exhibit broadened mode linewidths.
5. Delamination of composites is assumed to return embedded fiber to the bare state, as exhibited by distinct narrowing of mode linewidths.
6. The short embedded sensor fiber should have chemical composition different from long coated or jacketed fiber leads. The shifted GAWBS spectra of each type of fiber would enable their separate detection.
7. Fiber with 80 micron cladding has significantly broader GAWBS mode linewidths than that of fiber with 125 micron cladding. This seems to indicate a greater effect of the coating on the fiber with thinner cladding.
8. To sharpen mode linewidths of long fiber leads, it is suggested that these fibers preferably have thicker cladding, so as to reduce the effect of the coating. The embedded fiber should have thinner cladding so as to increase its sensitivity to the composite "coating" or "jacket".

PLANNED WORK

1. Continue systematic study of bare fiber GAWBS spectrum characteristics with fiber core and cladding size and composition.
2. Develop techniques to best embed bare fibers in composites.
3. In the case of bonding bare fibers to existing structural components, attempts will be made to develop methodology in stripping fiber coating, bonding bare fiber to the structural material and fiber long term protection against the ambient.
4. Bare fiber bonding to structural components for vibration testing.

BRILLOUIN ACTIVE SINGLEMODE FIBERS AND SENSING

C. Yu, Swee Cheng and Charles Collier

Department of Electrical Engineering, North Carolina A&T State University
Greensboro, NC 27411

Abstract: Brillouin scattering inherently reflects mainly the mechanical, thermal and chemical properties of the medium. Stimulated backward and resonant forward scattering exists in singlemode fibers, capable of sensing fiber parameter variations and the environment

In high resolution, low level Brillouin spectroscopy in bulky solids, the unavoidable finite angular spread, $\delta\theta$, of light was known to cause an increase in the linewidth of forward and backward Brillouin scattered light, proportional to $\delta\theta$ and $\delta\theta^2$ respectively^[1]. Such line broadening is intensified by highly confined geometry and waveguiding property of the singlemode optical fiber, the former, leading to relaxation of Bragg condition and the latter, coherent buildup of scattering intensity over fiber length. This forward spontaneous Brillouin scattering noise power has been estimated to reach 1/20 that of the incident laser power over a scattered linewidth of 500 Mhz in 600 Km of fiber at a laser wavelength of 1300 nm^[2]. Backward scattered light linewidth was computed to be much less than 100 Mhz, and of much lower intensity since it is second order back scattering, and hence less significant.

This forward Brillouin line broadening has recently been detected experimentally and shown to be composed of a line spectrum, characteristic of the fiber acoustic eigenmodes, and coined the Guided Acoustic Wave Brillouin Scattering (GAWBS) spectrum. This spectrum was readily detected electronically by a homodyne scheme in 3 Km down to 1m of fiber^[3]. Correlation is first noted here between the spontaneous forward Brillouin line broadening and the GAWBS spectrum, based on comparison of maximum Brillouin shifts (see Table 1). Increase in forward depolarized Brillouin scattering in different fiber length was demonstrated and the data presented in Fig. 1 for several dominant fiber eigenmodes.

Reference	Pump Wavelength (λ)	Core radius (a)	$\delta\theta = \lambda / \pi n a$ and $n=1.46$	$(f_B)_z$ GHz	Observed $(\delta f_B)_z$ MHz	Calculated Forward GAWBS $(\delta f_B)_z = (f_B)_z \times \delta\theta / 2$ MHz
Stone	1.3 μ m	3.5 μ m	0.08	12.7	—	500
Shelby	0.647 μ m	2.0 μ m	0.0686	26.5	800	910
Shiraki	1.55 μ m	2.5 μ m	0.135	11.3	—	764
Yu	1.319 μ m	4.9 μ m	0.0587	13.2	400	387
Perlmutter	0.647 μ m	2.5 μ m	0.0564	26.5	900	748
Poustie	1.321 μ m	—	—	—	875	—

Table 1 Maximum GAWBS bandwidth

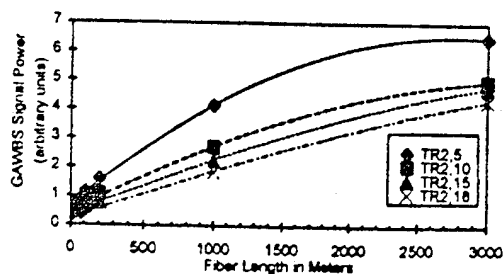

Fig.1 4 modes of GAWBS versus fiber length

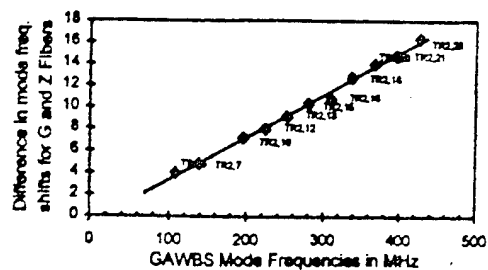

Fig.2 GAWBS mode frequency shifts for Litespec G (Germanium doped) & Z (pure silica core) fibers

The ready observation of GAWBS as first order forward scattering at incident laser power levels much lower than the standard backward stimulated Brillouin scattering (sBs) threshold has also been theorized by Corvo^[5] for cw laser sources. His prediction of Brillouin shifts increasing with radius of the annular rings of light emerging from the fiber exit end agrees with Stone's diffraction theory^[2]. The depolarizing property of GAWBS has been shown by Marcuse^[6] based on periodic variation in fiber radius, causing birefringence in the fiber. Shelby's TR_{2m} fiber acoustic eigenmodes producing the GAWBS spectrum matched the theory by Jen^[7] using the vanishing of acousto-optic coupling integrals based on symmetry in fiber birefringence, reducing depolarizing fiber acoustic modes to TR_{2m} modes only.

The torsional-radial TR_{2m} acoustic eigenmodes of the fiber core-cladding geometry, existing mainly in the cladding (a 9 μ m diameter core and a 125 μ m diameter cladding for a single-mode fiber), induce birefringence in the core that depolarizes the transmitted light. These modes have been simulated by us in Table 2, which clearly depicts the

Mode	Birefringence	Arrow Plot	Mode	Birefringence	Arrow Plot
TR_{24}	LoBi		TR_{26}	Zero Bi	
TR_{25}	Strong Bi		TR_{210}	Hi Bi	

Table 2 TR_{2m} mode birefringence chart

depolarizing efficiency of some of the modes. For instance, high-birefringence (HiBi) can be seen for modes such as TR_{25} , and TR_{210} , and a host of other modes with similar mode patterns around the fiber core, while TR_{22} , TR_{24} , TR_{25} modes and those which have circular acoustic mode patterns with low birefringence (LoBi), are not detected in our polarization sensitive setup. The frequencies of these modes are function of the fiber diameter and core-cladding chemical composition. As observed by Shiraki^[8] and us, shift of the TR_{2m} spectrum can be calibrated to measure fiber cladding diameter, concentricity, ovality (see Table.3) and chemical composition (see Fig.2). In Table 3, cladding diameter variation not only shifts the GAWBS spectrum but also alters it when cladding diameter drops to 80 μ m, due possibly to increase in core-cladding interaction. Furthermore, individual shifts have been observed by us to increase with mode order as predicted by Corvo's annular rings, so that higher resolution can be achieved by monitoring shifts in higher-order modes (see Fig.2). GAWBS mode spectrum modification in addition to the overall shift due to cladding thickness reduction deserves further theoretical and experimental investigation. This first order scattering effect, dependent totally in fiber parameters, has very significant implication in sensor applications.

The sensing capabilities both of sBs and GAWBS mechanisms have been thoroughly explored and the findings summarized and tabulated (see table 3). The sBs sensing scheme, based on sensitivity of the Stokes frequency shift to various ambient conditions and fiber parameters, is an excellent fiber sensor for temperature, strain and chemical composition of fiber, directly applicable to corrosion sensing. However, since this is a stimulated process with a

threshold that is dependent on laser power launched into the fiber and fiber length, excessive sensor length may have to be used for low power laser sources. Its backscattering characteristic is very desirable in constructing a robust and fault tolerant system, since any fiber breakage can be engineered to have a minimum effect on sensor performance. Dual sBs and GAWBS sensing is possible in the same system, since the latter is a forward scattering phenomenon, and has no

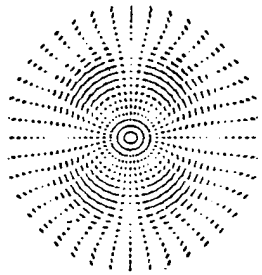
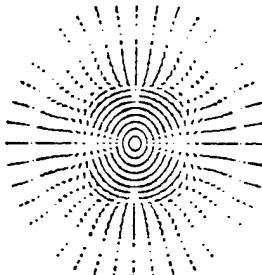
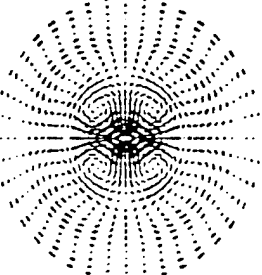
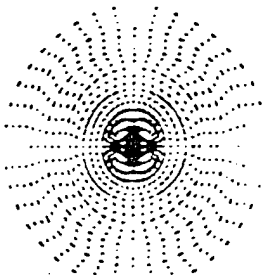
Table 3 *Fiber parameters and experimental result*

Fiber Parameters				Experimental Result	
Fiber mfd	ZSM-15 9.83 μm				
section element	core mole%	clad 1 mole%	clad 2 mole%		
GeO ₂	0.000	---	---		
Cl	0.584	0.584	0.584		
F	---	1.196	1.196		
Fiber mfd	GSM-13 9.18 μm				
section element	core mole%	clad 1 mole%	clad 2 mole%		
GeO ₂	2.887	0.000	---		
Cl	0.584	0.584	0.000		
F	0.091	0.091	0.000		

(a): 125 μm cladding, 9.83 μm core Litespec 'ZSM-15' 1000m fiber
 (b): Fiber (a) + 125 μm cladding, 9.18 μm core Litespec 'GSM-13' 205m fiber
 (c): 80 μm cladding, 6.6 μm core 3M 100m fiber.

threshold, as demonstrated by ready observability at 10m of fiber with modest laser power. GAWBS is particularly sensitive to transverse fiber deformations, such as cladding size change, due to the very transverse nature of the TR_{2m} modes. Its corrosion sensing potential, especially in its high sensitivity to cladding chemical composition variations, can not be underestimated.

Since GAWBS consists of a spectrum up to 2 Ghz, easily manageable electronically through heterodyne detection, it is richer in information content with respect to the fiber host environment, except temperature. This is a plus, since high temperature sensitivity would make the sensor difficult to be field deployable, especially in varying ambient temperatures, for which the sensor must be constantly recalibrated. Thus, GAWBS can be multimeasurand, as presented in the table.

The key question probably is the minimum fiber length necessary for acceptable GAWBS detection with adequate mode resolution. At this point, we expect to perform sensing with 10m of fiber with acceptable mode resolution using reduced cladding (80 micron or less) and reduced core (core radius 3 micron or less) fibers. Another technological challenge is the matching of sensor fibers to conventional 4.5 micron core, 125 micron cladding fibers.

The GAWBS sensing scheme is by far the simplest schemes in its implementation. It satisfies many of the requirements for sensing deformation and vibration in large structures, such as being a single continuous sensing element, having the ability to measure magnitude and location of physical observable, structurally non-invasive, negligible mass, and having signal processing capabilities to identify all modes of structural disturbances.

We have concluded from the above extensive study that a dual sensor based on both sBs and GAWBS would be our choice as a structural integrity sensor (Table 4). sBs would be used for temperature and longitudinal strain sensing, while GAWBS would be used for sensing torsional-shear strains, structural deformation, vibrations, and corrosion. The multimeasurand sensor can be implemented with total electronic detection using the 2 Ghz. Broadband detector for GAWBS heterodyne detection and the 20 Ghz New Focus detector with appropriate HP RF plug-in unit for sBs heterodyne detection.

Table 4: Sensing Mechanism and Possible Applications

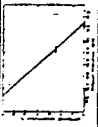
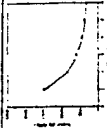
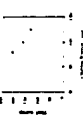
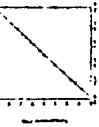
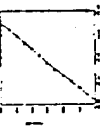
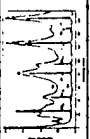
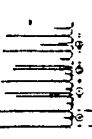
Fiber Parameter	Ambient	SBS			C/AWRS				
		Sensing Implication	Frequency Shift	Linewidth	Sensing Implication	Frequency Shift	Spectrum	Bandwidth	Linewidth
Core Doping				Broad ≈ 100MHz		Yes	Same		
Cladding Doping					Corrosion	Linear	Same		
Core Diameter									
Cladding Diameter 12.5µm 100µm 80µm					Mechanical Deformation				
	Temperature	Yes			No	No			
	Strain	Yes			No	No			
	Jacket								
	Index Change								

It appears that structural corrosion maybe rendered directly detectable by employing "porous" fibers. Such fibers have been demonstrated to be highly sensitive to chemical gases and humidity due to the mechanism of selective absorption of light by these chemicals at various characteristic wavelengths.

These fibers were commercially drawn from highly transparent alkali borosilicate glass with typical diameters ranging from 150-300 microns. A small section of the fiber was phase separated by heat treatment at about 500°C, resulting in an alkali borate rich phase and a silica rich phase. The soluble alkali borate phase was leached away by suitable acid solution to leave a silica rich porous skeleton. This porous durable, high-silica fiber glass skeleton was generally quite flexible and strong, rarely experiencing breakage. This porous section was typically 0.5cm long. The average pore size was approximately 80-150nm.

As a direct chemical sensor, the skeleton was coated with an aqueous solution, such as $\text{CoCl}_2 \cdot 6\text{H}_2\text{O}$, and then dried at room temperature. The light absorption spectrum of the coating varied with humidity.

In our application using the GAWBS spectrum, light absorption is not the main issue. Thus, such a coating will not be applied. Instead, the fiber will be leached so that the skeleton is formed at the cladding. The exposed cladding will then be exposed to external chemical environment, conducive to corrosion. Changes in cladding chemical composition, resulting from corrosion, is expected to affect the GAWBS spectrum.

Acknowledgment: This work is supported by Grant 93-G-0011 of Federal Aviation Administration, and Grants DAAH04-93-G-0488 and DAAH04-95-1-0197 of U.S. Army Research Office.

References

1. DURAND G. E., and PINE A. S.: 'High-resolution low-level Brillouin spectroscopy in solids'. *J. of Quantum Electronics*, Vol. QE-4, No. 8, Sept. 1968, p. 523-528.
2. STONE J., and CHRAPLYVY A. R. : 'Spontaneous Brillouin noise in long-distance high-bandwidth optical-fiber transmission'. *Electronics Letters*, Vol. 19, No. 8, 14th April 1983, p. 275-277.
3. SHELBY R. M., LEVENSON M. D., and BAYER P. W.: 'Guided acoustic-wave Brillouin scattering'. *Physical Review B*, Vol. 31, No. 8, 15th April 1985, p. 5244-5252.
4. SHIRAKI K., and OHASHI M. : 'Sound velocity measurement based on guided acoustic-wave Brillouin scattering'. *IEEE Photonics Tech. Lett.*, Vol. 4, No. 10, Oct. 1992, p. 1177-1180.
5. CORVO A., and GAVRIELIDES A. : 'Forward stimulated Brillouin scattering'. *J. Appl. Phys.* Vol. 63, No. 11, June 1988, p. 5220-5227.
6. MARCUSE D. : 'Theory of dielectric optical waveguide'. *Academic Press, New York*, 1991.
7. JEN C. K., and GOTO N.: 'Backward collinear guide-wave-acoustic-optic interactions in single-mode fibers'. *Journal of Lightwave Technology*, Vol. 7, No. 12, Dec. 1989, p. 2018-2023.
8. OHASHI M., SHIBATA N., and SHIRAKI K. : 'Fiber diameter estimation based on guided acoustic wave Brillouin scattering'. *Optical Fiber Communication Conf.*, Vol. 5, 1992 OSA Tech. Digest Series, Optical Society of America, Washington DC, 1992, paper WK3.