

NASA TECHNICAL NOTE

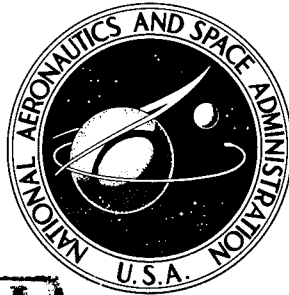

NASA TN D-4565

NASA TN D-4565

DISTRIBUTION STATEMENT A
Approved for public release
Distribution Unlimited

19960607 089

DEPARTMENT OF DEFENSE
PLASTICS TECHNICAL EVALUATION CENTER
PICATINNY ARSENAL, BOVER, N. J.

FRICITION AND WEAR IN CRYOGENIC LIQUIDS
FOR COMPOSITES OF PHENOLIC AND
OF POLYTETRAFLUOROETHYLENE OF VARIOUS
PARTICLE SIZES AND CONCENTRATIONS

*by Donald W. Wisander, Lawrence P. Ludwig,
and Robert L. Johnson*

*Lewis Research Center
Cleveland, Ohio*

DTIC QUALITY INSPECTED 3

NATIONAL AERONAUTICS AND SPACE ADMINISTRATION • WASHINGTON, D. C. • MAY 1968

PLASTECH 11367

11367

NASA TN D-4565

FRICITION AND WEAR IN CRYOGENIC LIQUIDS FOR COMPOSITES
OF PHENOLIC AND OF POLYTETRAFLUOROETHYLENE OF
VARIOUS PARTICLE SIZES AND CONCENTRATIONS

By Donald W. Wisander, Lawrence P. Ludwig, and Robert L. Johnson

Lewis Research Center
Cleveland, Ohio

NATIONAL AERONAUTICS AND SPACE ADMINISTRATION

~~For sale by the Clearinghouse for Federal Scientific and Technical Information
Springfield, Virginia 22151 - CFSTI price \$3.00~~

ABSTRACT

Experiments conducted with phenolic-PTFE (polytetrafluoroethylene) composites sliding against 440-C steel in liquid nitrogen and in liquid hydrogen showed that lubricating properties of phenolic can be improved by the addition of as little as 15 weight percent of PTFE. Experiments further showed that 15 weight percent PTFE of the 0.2- to 8-micron particle size gave the best results in both liquid nitrogen and in liquid hydrogen. Compressive-modulus and shear-strength tests at room temperature and in liquid nitrogen indicated that these properties were reduced by a factor of 2 to 3 by the addition of 15 weight percent PTFE.

FRICION AND WEAR IN CRYOGENIC LIQUIDS FOR COMPOSITES
OF PHENOLIC AND OF POLYTETRAFLUOROETHYLENE OF
VARIOUS PARTICLE SIZES AND CONCENTRATIONS

by Donald W. Wisander, Lawrence P. Ludwig, and Robert L. Johnson

Lewis Research Center

SUMMARY

Authors modified
Phenolic (phenol formaldehyde)-PTFE (polytetrafluoroethylene) composites were tested in sliding contact with 440-C steel in liquid nitrogen and in liquid hydrogen to determine the effect of percent composition and PTFE particle size on the friction and wear properties of the composite. Also of importance was the effect of the PTFE (amount and particle size) on the compressive modulus and shear strength of the composite; these tests were conducted at room temperature and in liquid nitrogen.

Experiments were conducted with a hemispherically tipped ($3/16$ -in. or 4.76-mm rad) rider sliding against the flat surface of a 440-C steel disk submerged in the liquid. The load applied to the rider was 1 kilogram, and the sliding velocity was 2300 feet per minute (701 m/min).

Test results indicated that the addition of PTFE to phenolic reduces the friction coefficient by a factor of 2 in liquid nitrogen (no reduction in liquid hydrogen) and reduces the wear rate by a factor of 100 in liquid nitrogen and by a factor of 10 in liquid hydrogen. Additions of PTFE of more than 15 percent by weight did little to improve the lubricating properties. Shear strength and compressive modulus were reduced by a factor of 2, with most of the reduction occurring at or before the addition of the 15 weight percent PTFE. The best combination of composite strength and lubricating properties was achieved with the addition of 15 weight percent PTFE with particle sizes of 0.2 to 8 microns.

INTRODUCTION

Rotating machinery for cryogenic applications, such as the rocket engine turbopumps, employs rolling-element bearings operating submerged in cryogenic fluids (refs. 1 and 2).

These bearings have surfaces, both in sliding and in rolling motion, which must be adequately lubricated in order to meet the goals of reliability and operating life. In addition to bearings, rocket engine turbopumps contain contact seals that are exposed to cryogenic fluid and operate at high sliding velocities.

A liquid lubricant, such as oil, ordinarily performs two primary functions: (1) separates solid surfaces having sliding and/or rolling relative motion, and (2) removes heat generated either in shearing the lubricant and/or by sliding and rolling solid-surface contact. For rolling-element bearings and face-contact-seal applications, the cryogenic fluids perform only the cooling function, because their inherent low viscosity does not permit a significant development of hydrodynamic forces for lubricating purposes (ref. 1). Therefore, self-lubricating materials are necessary for satisfactory operation of bearings and seals in cryogenic fluids.

Numerous self-lubricating materials for cryogenic applications have been investigated (refs. 2 to 9). The conclusion reached from an extensive series of tests on ball bearings with various cage materials (ref. 2), operating submerged in liquid rocket propellants (liquid hydrogen, liquid oxygen, nitrogen tetroxide, and kerosene), was that a nonmetallic cage surface is desirable. Glass-fabric-supported PTFE (polytetrafluoroethylene) and glass-fiber-filled PTFE cages gave the best performance. However, the cage wear was higher with propellants than with oil. A phenolic cage was operated in liquid hydrogen with some success (ref. 2); however, high torque resulted from the high friction coefficient of the propellant-cleaned phenolic cage sliding on steel. Reference 10 reports significant improvement in the friction and wear of phenolic (in air at room temperature) with the addition of 5- to 10-micron size particles of PTFE. This addition of PTFE (15 vol. % or 21.4 wt. %) produced the lowest friction and wear. Since phenolic has a higher compressive strength than that of PTFE polymers, it is herein suggested that the addition of a PTFE filler in phenolics might improve friction and wear in cryogenic fluids without unduly reducing other mechanical properties such as tensile strength. (In comparison with commonly used PTFE composites, phenolic-PTFE composites have a lower thermal contraction and are less abrasive.)

The objectives of this investigation were

- (1) To determine the effect of filler (PTFE) particle size on the coefficient of friction and the wear rate of phenolic composites in liquid nitrogen and in liquid hydrogen
- (2) To determine the effect of filler (PTFE) percentage addition on the coefficient of friction and the wear rate of phenolic composites in liquid nitrogen and in liquid hydrogen
- (3) To determine the shear strength and modulus of elasticity of phenolic-PTFE composites in liquid nitrogen and at room temperature

The matrix material used in this investigation was a general purpose phenolic

powder; the fillers were PTFE powders with mean particle sizes of 0.2, 2, 8, and 25 microns. A filled PTFE (15 percent glass fiber and 85 percent PTFE) was selected as the reference material because it is comparable with several materials used successfully as bearing cages for cryogenic service (refs. 2, 4, and 11). The coefficient of friction and the wear rate of the reference material and of the phenolic composites were determined by sliding a hemispherically tipped rider of the composites against 440-C steel disks submerged in liquid nitrogen or in liquid hydrogen.

APPARATUS AND PROCEDURE FOR FRICTION AND WEAR STUDIES

The apparatus used in the friction and wear studies is shown in figure 1. The basic elements consisted of a hemispherically tipped, 3/16-inch- (4.76-mm-) radius rider specimen held in sliding contact with the lower flat surface of a $2\frac{1}{2}$ -inch- (63.5-mm-) diameter rotating disk. The experiments were conducted with specimens completely submerged in liquid nitrogen or in liquid hydrogen. The drive shaft supporting the disk specimen was driven by a hydraulic motor through a 6:1 speed increaser and provided a sliding velocity of 2300 feet per minute (701 m/min) for the data reported herein. Two sets of helium-purged contact seals (not shown in fig. 1) were used to prevent air leakage in and cryogenic liquid leakage out around the drive shaft.

The rider specimen was loaded to 1 kilogram against the rotating disk specimen by a helium-pressurized bellows assembly. Load and frictional force were continuously measured by load dynamometer rings mounted inside the environmental chamber.

The cryogenic fluid was transferred to the test chamber through a closed system. The storage vessel was pressurized to transfer the liquid and to maintain the liquid level.

The test chamber was cleaned with 100 percent ethyl alcohol prior to each run. After the cleaning and installation of specimens, the test chamber was closed, purged for 15 minutes with nitrogen or helium gas, and filled with the operating liquid. After the test chamber was full and the liquid boiling stabilized, the rider specimen was loaded against the disk, and the drive motor started and adjusted to the proper speed. The duration of most runs was 1 hour.

The frictional force was measured with a recording potentiometer used as a strain indicator. The wear of the rider specimen was determined by (1) measuring the wear-scar diameter, (2) continuously recording the rider specimen position measured by a linearly variable differential transformer.

The surfaces of the metal disk specimens were prepared as follows: (1) finished-ground to 4 root mean square, (2) scrubbed with moist levigated alumina, (3) washed in tap water, and (4) washed in distilled water. Phenolic rider specimens were cleaned with 100 percent ethyl alcohol just prior to the test.

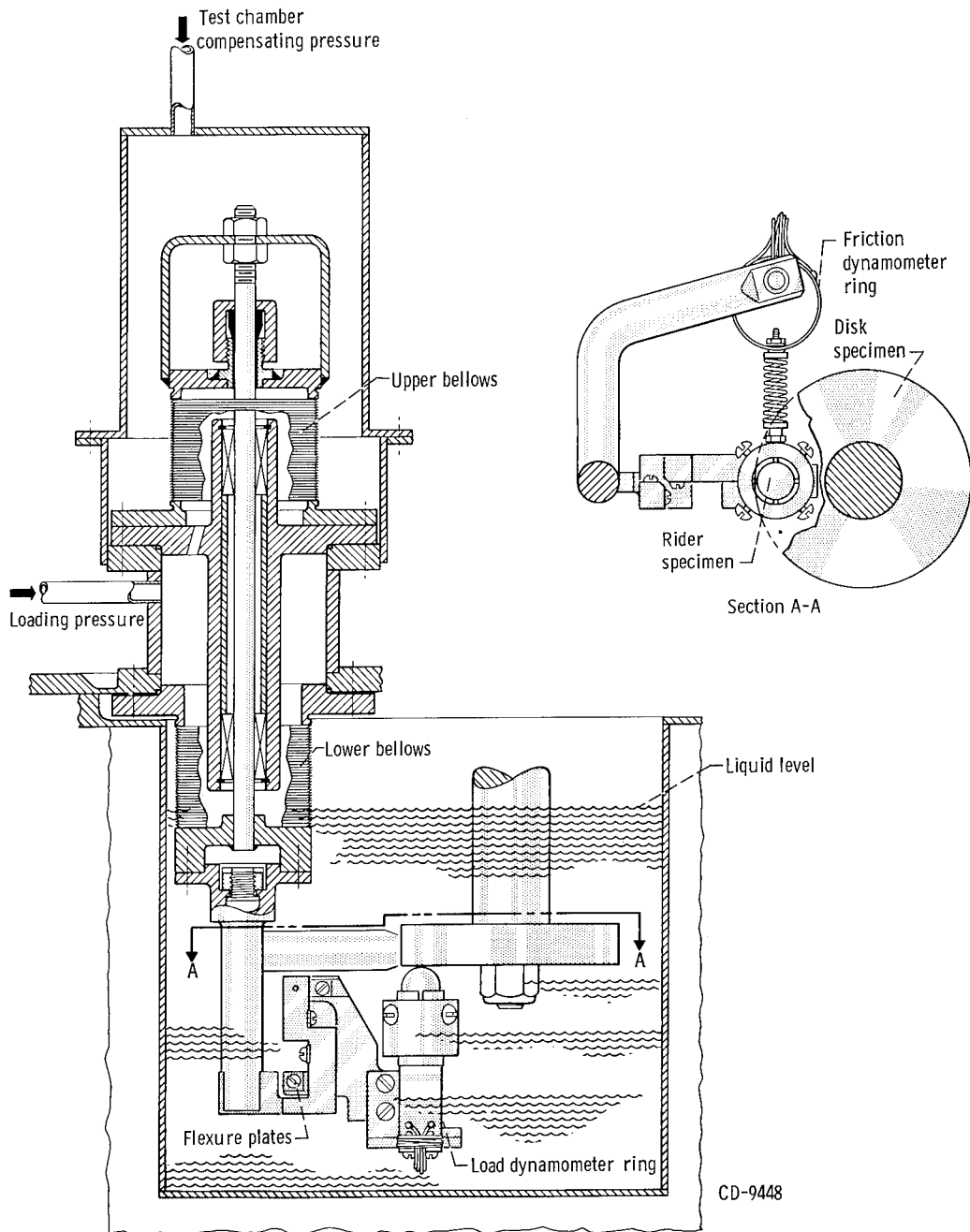

Figure 1. - Cryogenic fuel apparatus and specimen loading system.

MATERIALS AND PROCESSING

The materials evaluated in this report are listed in table I. The following procedure was used for processing these materials:

- (1) Phenolic molding compound was passed through a 10-mesh screen (0.066 in. sq or 1.7 mm sq).
- (2) Phenolic and PTFE powders were weighed and dry blended.
- (3) The blend was passed through heated differential rolls to produce a solid sheet.
- (4) The sheet was ground into powder and passed through the 10-mesh screen.
- (5) This powder was poured into a 4-inch- (100-mm-) diameter mold and cold pressed into a preform.
- (6) The preform was dielectrically heated to 210⁰ F (99⁰ C).
- (7) The preheated preform was charged into a fully positive (diametral clearance)

TABLE I. - PHENOLIC-PTFE (POLYTETRA-
FLUOROETHYLENE) COMPOSITES STUDIED

Phenolic material, wt. %	Polytetrafluoroethylene, wt. %	Mean particle size of polytetrafluoroethylene, μm
100	0	----
95	5	0.2
95	5	2
95	5	8
95	5	25
85	15	.2
85	15	2
85	15	8
85	15	25
80	20	2
80	20	8
80	20	25
75	25	.2
75	25	.2
75	25	8
75	25	25
65	35	.2
65	35	2
65	35	8
65	35	25

4-inch- (100-mm-) diameter mold (ASTM standard), heated to 330^o F (165.5^o C) under a pressure of 8000 psi (5.5×10^7 N/m²), and cured for 15 minutes.

(8) The preform was a disk, 4 inches (100 mm) in diameter and 3/8 inch (9.5 mm) in thickness, from which the specimens were machined.

APPARATUS AND PROCEDURE FOR DETERMINING SHEAR STRENGTH AND COMPRESSIVE MODULUS

The test apparatus for determining the shear strength and the compressive modulus consists of a precision tensile tester with a shear test jig and a compression test jig. A vacuum-jacketed test chamber with an anvil base was used for all tests; for low-temperature data, the chamber was filled with liquid nitrogen. Figure 2 shows part of tensile tester with the shear jig and vacuum-jacketed test chamber in position.

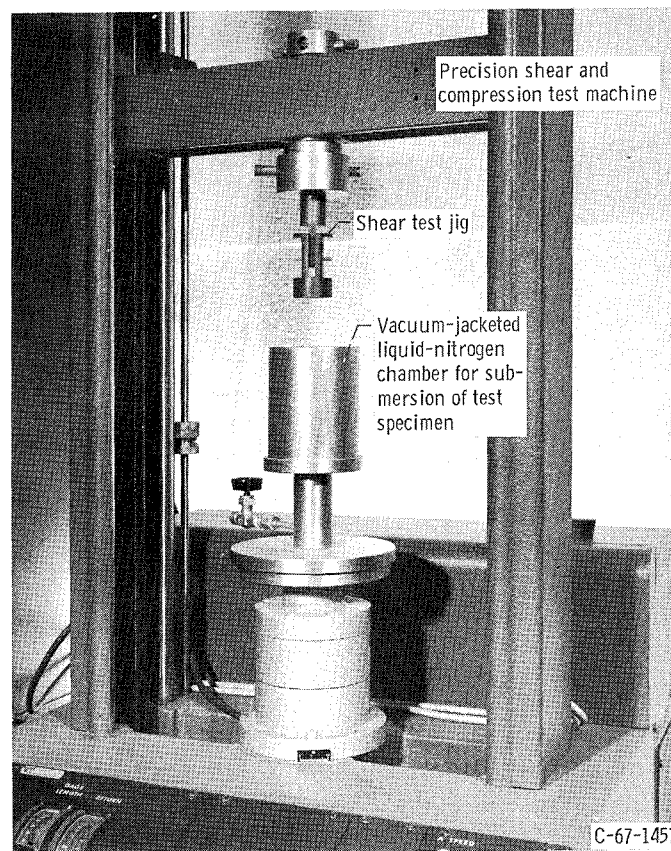
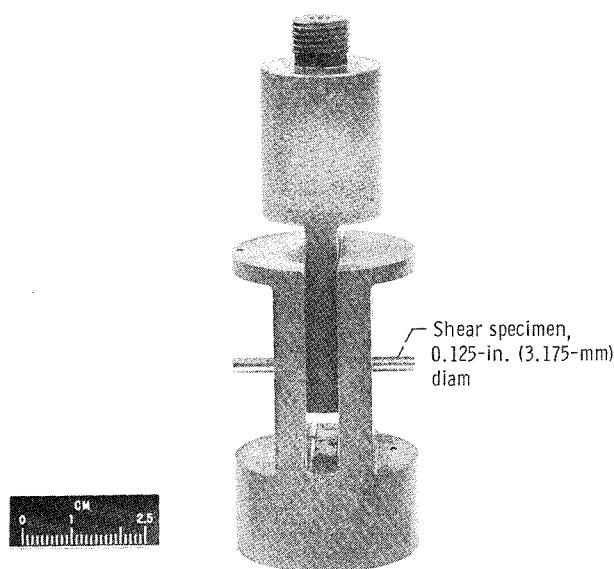

Figure 2. - Apparatus for determining room-temperature and liquid-nitrogen temperature shear strength.

Shear-Strength Procedure

Shear-strength tests were conducted using a specimen 0.125 ± 0.001 inch (3.175 ± 0.025 mm) in diameter by 1 inch (25.4 mm) in length. The specimen was mounted to give a double shear action, as indicated in figure 3. Specimens tested in liquid nitrogen were cooled for 3 to 4 minutes before shearing. (Tests conducted with cool-down times of 5 to 25 min revealed no change in specimen shear strength.) The rate of shear was 0.5 inch per minute (12.7 mm/min); changing the shear rate to 5 and to 0.05 inch per minute (127 and 1.27 mm/min) had no appreciable effect on the shear strength. Larger specimens (1/4-in. or 6.35-mm diam) had about a 20 percent higher shear strength. The



C-67-1459

Figure 3. - Shear test jig with shear specimen in position.

1/8-inch- (3.18-mm-) diameter size was used because the 1/4-inch- (6.35-mm-) diameter specimens with a low percentage of PTFE had shear loads beyond the range of the tensile tester (1000 lb or 455 kg).

Compressive-Modulus Procedure

Compression tests utilized the jig shown in figure 4. Specimen positions are also shown. The vertical posts facilitate the handling of the jig stand when the test chamber is filled with liquid nitrogen. The piston is mounted on the tensile tester (same as upper

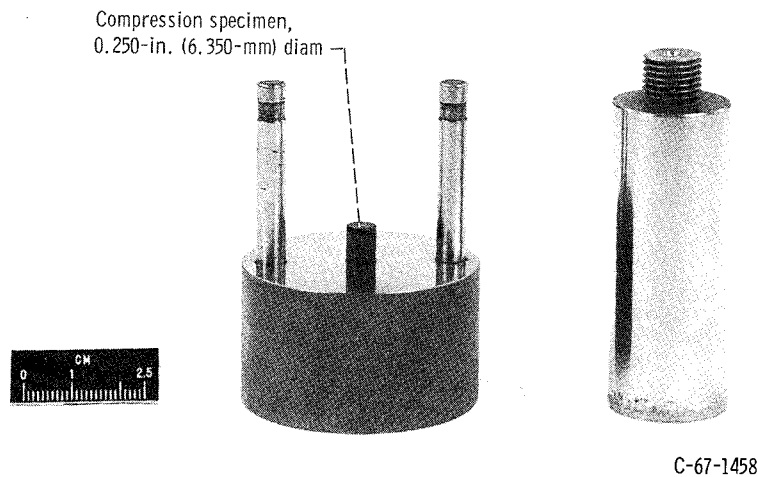

Figure 4. - Compression test jig with compression specimen in position.

section of shear bar in fig. 2). The specimens were 0.250 ± 0.001 inch (6.350 ± 0.025 mm) in diameter by 0.750 ± 0.001 inch (19.05 ± 0.025 mm) in length to give a slenderness ratio of 12. (ASTM-D695 suggests a slenderness ratio of between 11:1 and 15:1.) The slenderness ratio is defined as the length divided by the least radius of gyration (which, for a cylinder, is one-quarter of the diameter). Load as a function of deflection is continuously recorded by a strip-chart recorder. The compressive modulus is then obtained in the following manner: The slope of the most nearly straight portion of the curve is determined; the strain slope of the load cell is subtracted; and the result is multiplied by the ratio of length to area. The rate of compression was 0.05 inch per minute (1.27 mm (1.27 mm/min), and the maximum load was 200 pounds (91 kg). The maximum load for 100 percent PTFE was 50 pounds (23 kg).

RESULTS AND DISCUSSION

Mechanical Properties at Room Temperature

The mechanical-property data presented in figure 5 are not intended to be used for design but rather to show the property trends with the addition of PTFE to phenolic (phenol formaldehyde) and with the change from room temperature (75° F or 24° C) to liquid-nitrogen temperature (-320° F or 77° K). Data presented are typical of these tests; the variation is ± 20 percent. Figure 5(a) shows the decrease of shear strength with various percent compositions and particle sizes of PTFE added to the phenolic at room temperature (75° F or 24° C). Most of this decrease occurred with additions of PTFE between 15 and 20 weight percent, regardless of the particle size; for higher percentage compositions, the shear strength approached that of 100 weight percent PTFE. Shear strength

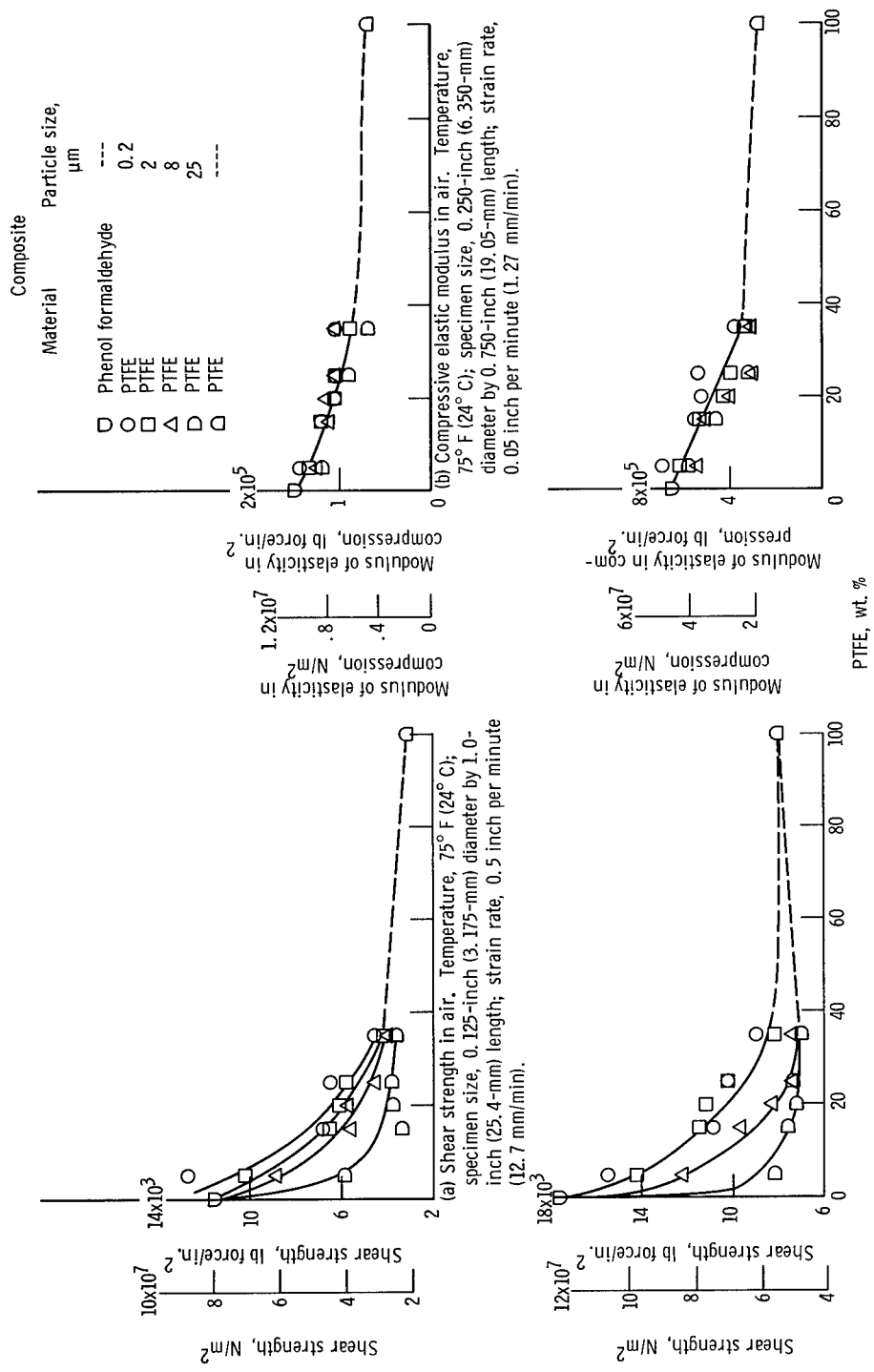

(a) Shear strength in air. Temperature, 75° F (24° C); specimen size, 0.125-inch (3.175-mm) diameter by 1.0-inch (25.4-mm) length; strain rate, 0.5 inch per minute (12.7 mm/min).

(b) Compressive elastic modulus in air. Temperature, 75° F (24° C); specimen size, 0.250-inch (6.350-mm) diameter by 0.750-inch (19.05-mm) length; strain rate, 0.05 inch per minute (1.27 mm/min).

(c) Shear strength in liquid nitrogen. Temperature, -320° F (77° K); specimen size, 0.125-inch (3.175-mm) diameter by 1.0-inch (25.4-mm) length; strain rate, 0.5 inch per minute (12.7 mm/min).

(d) Compressive elastic modulus in liquid nitrogen. Temperature, -320° F (77° K); specimen size, 0.250-inch (6.350-mm) diameter by 0.750-inch (19.05-mm) length; strain rate, 0.05 inch per minute (1.27 mm/min).

improved with decreasing particle size. With the largest particle size ($25\ \mu\text{m}$), the physical strength and integrity of the composite are affected; therefore, friction and wear data could not be obtained.

The modulus of elasticity (in compression) of the same composites is plotted in figure 5(b) to show the effect of varying the weight percent and the particle size of PTFE. (With the addition of PTFE, the effect on the elastic modulus is less than the effect on the shear strength.)

Mechanical Properties in Liquid Nitrogen

The shear strength of composites (fig. 5(c)), as expected, was higher (~ 40 percent) in liquid nitrogen (-320°F or 77°K) than at room temperature, and it was again reduced by the addition of PTFE. Most of this reduction was reached with an addition of about 15 weight percent PTFE for all particle sizes. Above 15 weight percent PTFE, the curves for the 8- and 25-micron particle fillers showed that the shear strength was slightly less than that for the 100 percent PTFE. This result indicates a decrease in the composite shear strength that might be partially caused by the differential contraction of the large particles, which creates voids and, hence, reduces the cross-sectional area. Cross-sectional area is difficult to calculate because the void content is unknown; the total thermal contractions of the phenolic and the PTFE and of the composite are easily measured. (Phenolic contracts about 0.2 percent and PTFE about 1.5 percent from room temperature to liquid-nitrogen temperature.)

The modulus of elasticity (compressive) is shown in figure 5(d). The modulus in liquid nitrogen is about four times as high as it is at room temperature, and again, as at room temperature the addition of PTFE (all particle sizes) decreases the modulus by a factor of 2 at 35 weight percent PTFE. The trend is reasonably linear up to an addition of 35 percent PTFE.

Comparison of Mechanical Properties at Room Temperature and in Liquid Nitrogen

Figure 5 shows that the shear strength and the compressive modulus of the composite are moderately reduced by the addition of PTFE at room temperature and in liquid nitrogen. Particle size and weight percent have a moderate influence on these properties. Reducing the temperature from 75°F (24°C) to -320°F (77°K) increases the compression modulus more than it does the shear strength (by 300 and 10 percent, respectively).

Although mechanical-property data in the literature (ref. 12) do not agree with that

obtained for PTFE in this investigation, it is important to note that the data presented herein are consistent. Also, the published data for cryogenic strength properties of polymers vary by a factor of 2 to 3 between authors.

Wear and Friction in Liquid Nitrogen

The wear rates of phenolic-PTFE composite riders are shown in figure 6(a). Wear is decreased by a factor of more than 100 by the addition of 15 weight percent PTFE (0.2 μm particle size). Larger additions of PTFE do not significantly reduce the wear; wear curves for all three particle sizes approach the wear of 100 percent PTFE. The most beneficial particle size appears to be the smallest (0.2 μm), which indicates a weakening effect of additives of the larger particle sizes, probably from differential contraction. For reference, a 15 weight percent glass-fiber-filled PTFE is included in the figure, which shows that the 15 weight percent PTFE-phenolic (particle size, 0.2 μm) has about the same wear as the reference material (85 percent PTFE and 15 percent glass fiber).

Figure 6(b) shows the friction coefficient for the same materials presented in figure 6(a). The coefficient of friction is only slightly reduced by the addition of PTFE of any particle size or weight percent and is similar to that of both the 100 percent PTFE and the reference material (85 percent PTFE and 15 percent glass fiber).

Wear and Friction in Liquid Hydrogen

The wear rates of the phenolic-PTFE composite in liquid hydrogen are shown in figure 6(c). The wear rate is reduced by a factor of 10 by the addition of 15 weight percent PTFE. Apparently, the wear of PTFE is affected more by the lower temperature of liquid hydrogen than is the phenolic, which explains the smaller improvement in wear of composites in liquid hydrogen than in liquid nitrogen with the addition of PTFE.

The coefficient of friction (fig. 6(d)) is essentially unaffected by the PTFE addition.

Comparison of Friction and Wear in Liquid Nitrogen and in Liquid Hydrogen

Figure 6 shows that phenolic-PTFE composites with small particle sizes (0.2 and 8 μm) have a wear trend, with increasing PTFE content, that includes PTFE as an end point. A comparison of figures 6(a) and (c) shows that the wear of phenolic is only three times as high in liquid hydrogen as it is in liquid nitrogen, but that the wear of PTFE is

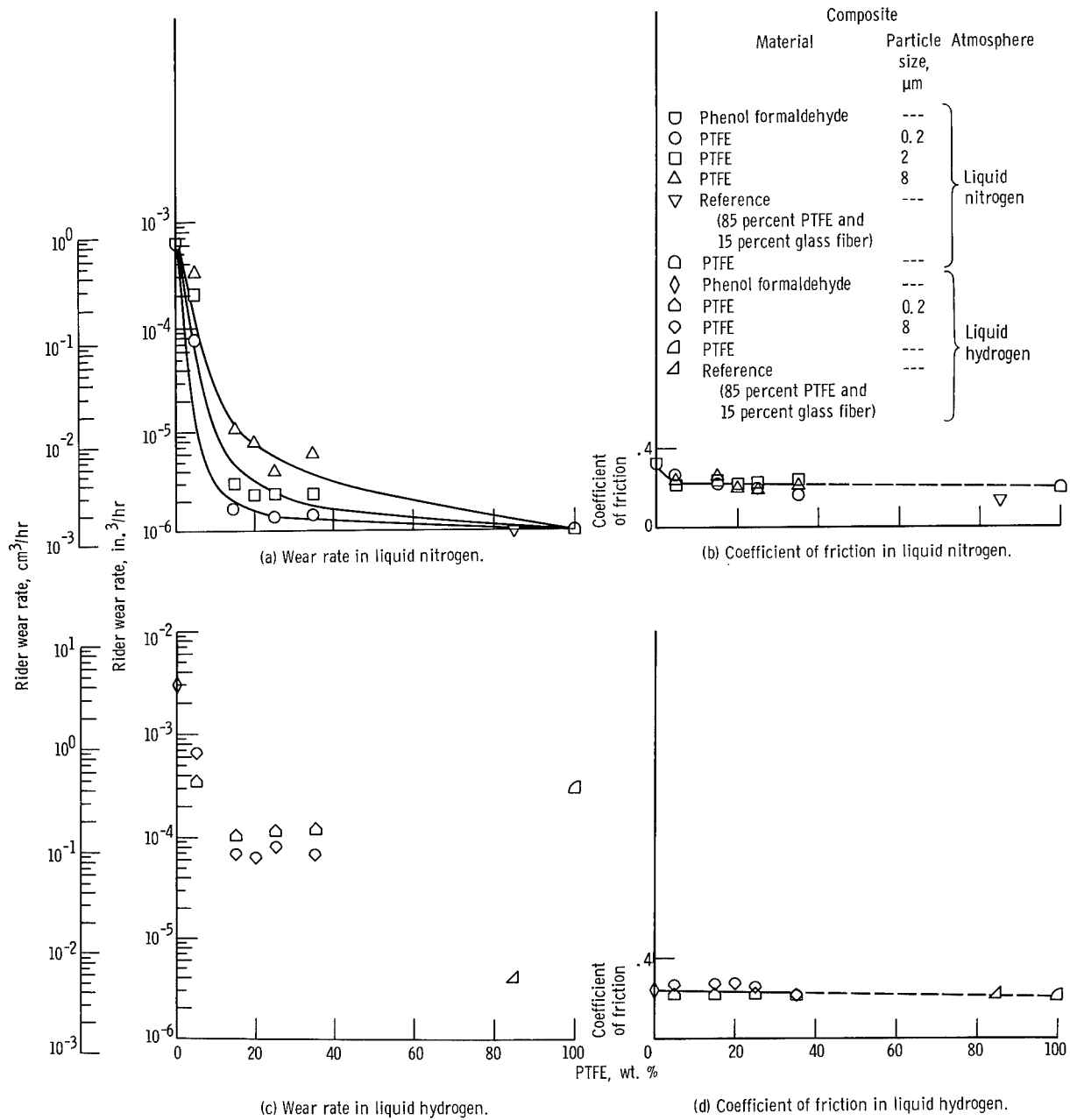

Figure 6. - Wear rate and coefficient of friction of phenolic (phenol formaldehyde)-PTFE (polytetrafluoroethylene) composite riders sliding against 440-C stainless-steel disks in liquid nitrogen and in liquid hydrogen. Sliding velocity, 2300 feet per minute (701 m/min); load, 1 kilogram; duration of run, 1 hour.

more than 100 times as high in liquid hydrogen as it is in liquid nitrogen. This comparison indicates the advantage of using phenolic as the base material of composites for use in liquid hydrogen.

The friction coefficient of phenolic-PTFE composites in liquid hydrogen (figs. 6(b) and (d)) is altered little by the composition, the particle size, or the temperature.

Lubrication Mode of Phenolic and of Composites

As can be seen in figure 7, when the friction coefficient of the 100 percent phenolic increases, the wear rate increases, which indicates a transfer film formation and a subsequent film breakdown. Reforming the film, after breakdown, requires wear of the lubricating member. When PTFE is added to the phenolic (note curves of 5 wt. % PTFE), the film is more easily formed, as evidenced by the reduced friction coefficient. Although the apparent life (fig. 7) of this transfer film is no better than that for the 100 percent phenolic, the total wear is less. Increasing the percentage of PTFE to 15 weight percent produces a material that can maintain a transfer film in excess of 1 hour; this composite has the same friction coefficient and the same wear rate as the 100 percent PTFE. Note, also, that the wear rate as well as the total wear has decreased. It can now be seen why additional PTFE (greater than 15 wt. %) is unnecessary; the film, once

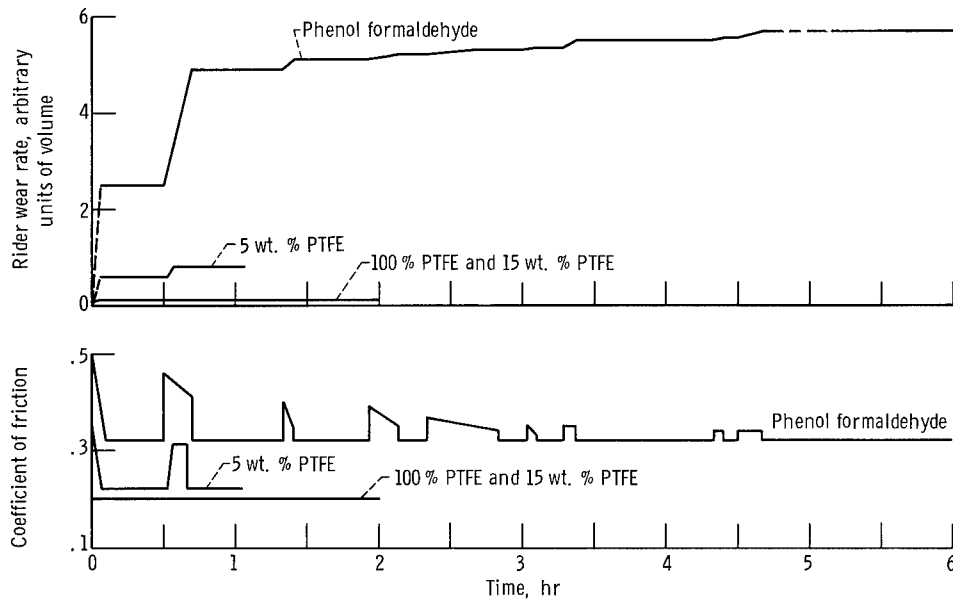

Figure 7. - Correlation of coefficient of friction with wear rate as function of time for phenolic (phenol formaldehyde) and phenolic composites with various percentages of PTFE (polytetrafluoroethylene) sliding against 440-C stainless steel in liquid nitrogen. PTFE particle size, 0.2 micron; sliding velocity, 2300 feet per minute (701 m/min); load, 1 kilogram.

properly formed, requires only maintenance, and more than 15 weight percent PTFE in the composite is not required. If the transfer film is easily worn away or if it is poorly bonded to the mating surface, the wear rate will be higher (note wear of the 100 percent phenolic and the 5 wt. % PTFE).

SUMMARY OF RESULTS

The following results were obtained from wear and friction studies of phenolic (phenol formaldehyde)-PTFE (polytetrafluoroethylene) composite riders sliding against 440-C steel disks in liquid nitrogen:

1. The addition of PTFE powder (5 to 35 wt. %) to a phenolic reduced its wear for all particle size fillers evaluated (0.2, 2, and 8 μm). PTFE additions greater than 15 percent by weight revealed little additional improvement in wear of the composite. The coefficient of friction, compressive modulus, and shear strength were reduced by a factor of about 2 by the addition of 15 weight percent (or more) PTFE. The smallest particle size of PTFE (0.2 μm) produced lower wear than did the larger sizes. The wear rates of the composites were not as low as that of the reference material (85 percent PTFE and 15 percent glass fiber) or that of the 100 percent PTFE; friction coefficients of the composites were as low as that of the 100 percent PTFE and of the reference material.

2. PTFE improved the wear of the composites by helping to maintain a lubricating transfer film on the mating surface.

The results of friction and wear studies in liquid hydrogen revealed the following:

1. The addition of PTFE to a phenolic reduced the wear of the composite by a factor of 10; an addition greater than 15 weight percent was unnecessary because the 15 weight percent PTFE produced a material that had the same wear rate as the 100 weight percent PTFE. Also, friction was not significantly improved.

2. The wear rate of phenolic-PTFE composites in liquid hydrogen was about 10 times that obtained in liquid nitrogen; friction was essentially the same in liquid hydrogen and in liquid nitrogen.

3. Composites with 15 weight percent PTFE or more had lower wear rates than that of 100 percent PTFE but greater than that of the reference material (85 percent PTFE and 15 percent glass fiber); the friction coefficients of these composites were comparable with that of the reference material and that of the 100 percent PTFE.

Lewis Research Center,
National Aeronautics and Space Administration,
Cleveland, Ohio, February 1, 1968
129-03-13-01-22.

REFERENCES

1. Bisson, Edmond E. ; and Anderson, William J. : Advanced Bearing Technology. NASA SP-38, 1964.
2. Butner, M. F. ; and Rosenberg, J. C. : Lubrication of Bearings with Rocket Propellants. Lubrication Eng., vol. 18, no. 1, Jan. 1962, pp. 17-24.
3. Wisander, Donald W. ; Ludwig, Lawrence P. ; and Johnson, Robert L. : Wear and Friction of Various Polymer Laminates in Liquid Nitrogen and in Liquid Hydrogen. NASA TN D-3706, 1966.
4. Wisander, D. W. ; Hady, W. F. ; and Johnson, R. L. : Friction Studies of Various Materials in Liquid Nitrogen. NACA TN 4211, 1958.
5. Wisander, D. W. ; and Johnson, R. L. : A Solid Film Lubricant Composition for Use at High Sliding Velocities in Liquid Nitrogen. ASLE Trans., vol. 3, no. 2, 1960, pp. 225-231.
6. Wisander, D. W. ; and Johnson, R. L. : Wear and Friction in Liquid Nitrogen with Austenitic Stainless Steel Having Various Surface Coatings. Advances in Cryogenic Engineering. Vol. 4. K. D. Timmerhaus, ed., Plenum Press, Inc., 1960, pp. 71-83.
7. Wisander, Donald W. ; Maley, Charles E. ; and Johnson, Robert L. : Wear and Friction of Filled Polytetrafluoroethylene Compositions in Liquid Nitrogen. ASLE Trans., vol. 2, no. 1, Apr. 1959, pp. 58-66.
8. Wisander, D. W. ; and Johnson, R. L. : Wear and Friction of Impregnated Carbon Seal Materials in Liquid Nitrogen and Hydrogen. Advances in Cryogenic Engineering. Vol. 6. K. D. Timmerhaus, ed., Plenum Press, Inc., 1961, pp. 210-218.
9. Rempe, W. H., Jr. : Research and Development of Materials for use as Lubricants in a Liquid Hydrogen Environment. Trans. ASLE, vol. 9, no. 3, July 1966, pp. 213-221.
10. Willis, D. P., Jr. ; and O'Rourke, J. T. : Evaluation of Self-Lubricating Bearing Materials Made From Phenolic Molding Compounds. Plastics Des. Processing, vol. 4, no. 4, Apr. 1964, pp. 14-19.
11. Scibbe, Herbert W. ; and Anderson, William J. : Evaluation of Ball-Bearing Performance in Liquid Hydrogen at DN Values to 1.6 Million. ASLE Trans., vol. 5, no. 1, Apr. 1962, pp. 220-232.
12. Anon. : Properties of "Teflon" at Cryogenic Temperatures. J. Teflon, vol. 8, no. 2, Mar.-Apr. 1967, pp. 4-7.

NATIONAL AERONAUTICS AND SPACE ADMINISTRATION
WASHINGTON, D. C. 20546
OFFICIAL BUSINESS

POSTAGE AND FEES PAID
NATIONAL AERONAUTICS AND
SPACE ADMINISTRATION

FIRST CLASS MAIL

03U 001 40 50 3DS 68120 00942
PICATINNY ARSENAL
PLASTICS TECHNICAL EVALUATION CENTER
DOVER, NEW JERSEY 07801

3621

ATT SMUPA-VP3

POSTMASTER: If Undeliverable (Section 158
Postal Manual) Do Not Return

"The aeronautical and space activities of the United States shall be conducted so as to contribute . . . to the expansion of human knowledge of phenomena in the atmosphere and space. The Administration shall provide for the widest practicable and appropriate dissemination of information concerning its activities and the results thereof."

— NATIONAL AERONAUTICS AND SPACE ACT OF 1958

NASA SCIENTIFIC AND TECHNICAL PUBLICATIONS

TECHNICAL REPORTS: Scientific and technical information considered important, complete, and a lasting contribution to existing knowledge.

TECHNICAL NOTES: Information less broad in scope but nevertheless of importance as a contribution to existing knowledge.

TECHNICAL MEMORANDUMS: Information receiving limited distribution because of preliminary data, security classification, or other reasons.

CONTRACTOR REPORTS: Scientific and technical information generated under a NASA contract or grant and considered an important contribution to existing knowledge.

TECHNICAL TRANSLATIONS: Information published in a foreign language considered to merit NASA distribution in English.

SPECIAL PUBLICATIONS: Information derived from or of value to NASA activities. Publications include conference proceedings, monographs, data compilations, handbooks, sourcebooks, and special bibliographies.

TECHNOLOGY UTILIZATION PUBLICATIONS: Information on technology used by NASA that may be of particular interest in commercial and other non-aerospace applications. Publications include Tech Briefs, Technology Utilization Reports and Notes, and Technology Surveys.

Details on the availability of these publications may be obtained from:

SCIENTIFIC AND TECHNICAL INFORMATION DIVISION
NATIONAL AERONAUTICS AND SPACE ADMINISTRATION
Washington, D.C. 20546