

AFML-TR-71-154

PBI TOW MANUFACTURING METHODS

Arthur E. Prince

CELANESE RESEARCH COMPANY
a division of
CELANESE CORPORATION

TECHNICAL REPORT AFML-TR-71-154

August 1971

This document has been approved for public release and sale;
its distribution is unlimited.

Air Force Materials Laboratory.
Air Force Systems Command
Wright-Patterson Air Force Base, Ohio

19960607 114

DTIC QUALITY INSPECTED 3

PLASTED 16783

DISCLAIMER NOTICE

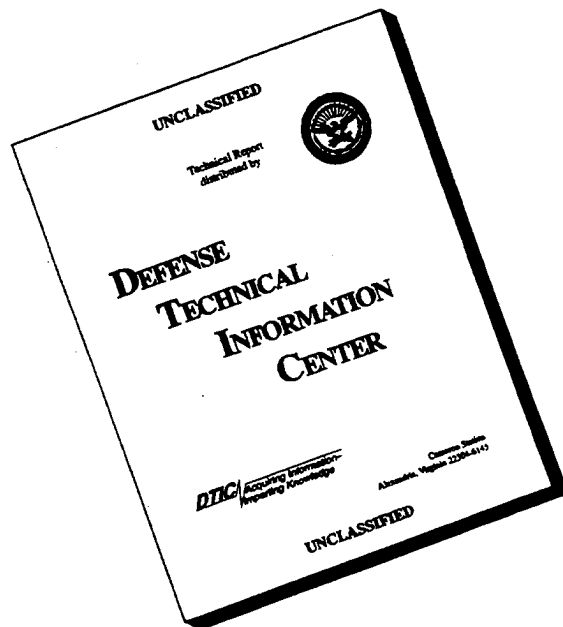

THIS DOCUMENT IS BEST QUALITY AVAILABLE. THE COPY FURNISHED TO DTIC CONTAINED A SIGNIFICANT NUMBER OF PAGES WHICH DO NOT REPRODUCE LEGIBLY.

NOTICES

When Government drawings, specifications, or other data are used for any purpose other than in connection with a definitely related Government procurement operation, the United States Government thereby incurs no responsibility nor any obligation whatsoever; and the fact that the Government may have formulated, furnished, or in any way supplied the said drawings, specifications, or other data, is not to be regarded by implication or otherwise as in any manner licensing the holder or any other person or corporation, or conveying any rights or permission to manufacture, use, or sell any patented invention that may in any way be related thereto.

Copies of this report should not be returned unless return is required by security considerations, contractual obligations, or notice on a specific document.

PBI TOW MANUFACTURING METHODS

Arthur E. Prince

CELANESE RESEARCH COMPANY
a division of
CELANESE CORPORATION

FOREWORD

This Technical Report covers work performed under Contract F33615-70-C-1266 from 1 December 1969 to 30 June 1971. It is published for information only and does not necessarily represent the recommendations, conclusions or approval of the Air Force.

This contract with Celanese Research Company, Summit, New Jersey, was initiated under Project 389-9, "Manufacturing Methods and Processes for Production of PBI Tow and Staple Fiber". It was accomplished under the technical direction of Mr. C. S. Anderson of the Materials Processing Branch, Manufacturing Technology Division, Air Force Materials Laboratory, Wright-Patterson AFB, Ohio.

Mr. Arthur E. Prince, Senior Research Chemist, was the Principal Investigator, and Mr. K. S. Burns, Section Head, was Project Leader and Dr. J. R. Leal, Senior Staff Associate, was the Contract Administrator. Other Celanese contributors to this effort were: (1) Operations: A. Catenacci, R. L. Conrad, J. J. Cunningham, & J. A. Imhof (2) Engineering: J. V. Borowski, H. Kuhnau, & D. T. Vest (3) Analytical: R. E. Majors (4) Plant Design & Economics: N. Barson & A. Wakefield (5) Spinning Production: R. E. Swander (6) Polymer Characterization: C. M. Vogt.

This project has been accomplished as part of the Air Force Manufacturing Methods Program, the primary objective of which is to implement, on a timely basis, manufacturing processes and techniques for use in economical production of USAF materials and components. The program encompasses the following areas:

- Metallurgy - Rolling, Forging, Extruding, Casting, Drawing, Powder Metallurgy, Composites
- Chemical - Propellants, Coatings, Ceramics, Graphites, Non-metallics
- Electronic - Solid State, Materials and Special Techniques, Thermionics
- Fabrication - Forming, Materials Removal, Joining, Components

Suggestions concerning additional manufacturing methods required on this or other subjects will be appreciated.

This technical report has been reviewed and is approved.

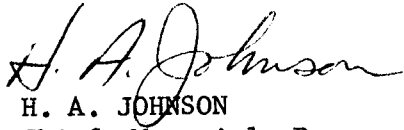

H. A. JOHNSON
Chief, Materials Processing Branch
Manufacturing Technology Division

ABSTRACT

The purpose of this project was to (a) scale-up the single stage polymerization process (b) increase spinning productivity (c) establish a tow process for processing large bundles of yarn in a continuous manner (d) produce 500 lbs of quality product, and (e) revise the projected economics of a 1 MM lb/yr production plant.

The scale-up of the single-stage PBI polymerization process in a specially designed 50-gallon reactor was successful with the attainment of polymer I. V. 's in the 0.7 to 0.9 range at the target capacity level. Insufficient time was available, however, to fully optimize the process conditions.

Spinning productivity was nearly doubled by establishing the ability to spin 200-hole jets. This was the maximum number of holes attainable in a single ring with the available pilot equipment; however, 300 or more holes could be employed in a commercial application. The potential for additional spinning productivity was demonstrated by spinning and drawing higher filament deniers to give target properties. New jet starting techniques were demonstrated. Large 5.5 lb packages were produced with both columns being run simultaneously.

Continuous washing, drying, and drawing in tandem was demonstrated with PBI tows of 1000 to 5000 filaments. Target properties were achieved and a total of 500 lbs of tow was produced.

A revised preliminary plant design was prepared for a 1 MM lb/yr PBI plant producing 0.8 MM lb/yr of staple and 0.2 MM lb/yr of filament yarn. The production cost, assuming \$5.00/lb for DAB and \$1.00/lb for DPIP, was \$7.56/lb overall. The biggest factor is obviously the purchase price of DAB which accounts at this price level for two-thirds of the production cost.



November 5, 1971

Subject: Technical Report AFML-TR-71-154
Contract No. F33615-70-C-1266

The enclosed technical report is submitted to you for your information and retention in accordance with the distribution list supplied by the Manufacturing Technology Division, LTP, Air Force Materials Laboratory, Wright-Patterson Air Force Base, Ohio.

Very truly yours,

A handwritten signature in cursive script that reads 'Joseph R. Leal / JRL'.

Joseph R. Leal
Senior Staff Associate

JRL:pr

TABLE OF CONTENTS

	<u>Page</u>
INTRODUCTION AND OBJECTIVE	1
SUMMARY	2
DISCUSSION	5
Raw Materials	5
Polymerization	5
Historical Background	5
Scale-Up Objectives	6
Process Equipment and Shakedown	6
Polymerization Process Development	13
Polymer Characterization and Evaluation	15
Production	16
Dope Preparation	16
Process Description	16
Equipment Modifications.	17
Solubility of One and Two-Stage Polymers	17
Dope Stability	19
Spinning	22
Process Description	22
Physical Testing	23
Filament Deniers	23
Jet Starting Techniques	25
Multifilament Spinning	26
Steam Stretching	27
Accident Report	27
DMAc Condensate	29
Washing	30
Historical Background	30
DMAc Analysis	30
Initial Washing Trials	30
Continuous Immersion Washing	34
Continuous Spray Washing	38
Comparison of Washing Systems	38
Instron Tests	41
Equipment Design	41

TABLE OF CONTENTS (CONTINUED)

	<u>Page</u>
Drying	41
Background	41
Thermal Treatment of As-Spun Yarn	44
Initial Drying Trials	46
Tandem Drying and Drawing	46
Equipment Design	50
Single-Stage Polymer Evaluation	51
Summary	51
Dope Preparation	51
Spinning Evaluation	53
Drawing Evaluation	55
Tow Process	60
Demonstration	66
Summary	66
Polymerization	67
Dope Preparation	67
Spinning	67
Tow Processing	67
Plant Design and Economics	73
Summary	73
Process Design	73
Polymerization	73
Dope Preparation	74
Staple Spinning	74
Staple Processing	75
Filament Spinning	75
Filament Processing	75
Pollution Aspects	75
Economic Evaluation	76
Basis of Estimate	76
Production Cost	76
Capital Investment	77
Conclusions	77
CONCLUSIONS AND RECOMMENDATIONS	78
Polymerization	78
Dope Preparation	78

TABLE OF CONTENTS (CONTINUED)

	<u>Page</u>
Washing	79
Drying and Drawing	79
Tow Process and Demonstration	80
Plant Design and Economics	80
APPENDIX I - PBI SINGLE-STAGE POLYMERIZATION STANDARD OPERATING PROCEDURES	 97
PBI POLYMERIZATION CHARGE LEVELS	105
GLOSSARY	108
APPENDIX II - DETERMINATION OF RESIDUAL DIMETHYLACETAMIDE IN PBI YARN	 112
APPENDIX III - ACCEPTANCE TEST PROCEDURES	116

ABBREVIATIONS AND SYMBOLS

°C	degrees centigrade
DAB	3, 3'-diaminobenzidine
denier	weight in grams of 9000 meters
DMAc	dimethyl acetamide
dpf	denier per filament
DPIP	diphenyl isophthalate
Elong., E	elongation
°F	degrees fahrenheit
ft	foot, feet
fil	filament(s)
g	gram(s)
gal.	gallon(s)
GPM	gallon(s) per minute
g/d, GPD	gram(s) per denier
g/dl	gram(s) per deciliter
g/fil	gram(s) per filament
GC	gas chromatography
hr, hrs	hour(s)
in	inch(es)
I. V.	inherent viscosity
KWH	kilowatt hour
lb, lbs	pound(s)
lb/hr	pound(s) per hour
LiCl	lithium chloride
M	thousand
MM	million
m	meter
min	minute
MBTU	thousand British thermal units
m/min	meters per minute
MS	mass spectrography
μ	micron
P. V.	plugging value
psig	pounds per square inch gauge
%	percent
RPM	revolutions per minute
scf	standard cubic feet
SCFH	standard cubic feet per hour
SCFM	standard cubic feet per minute
TCR	temperature controller recorder
TE $\frac{1}{2}$	tensile factor (T E)
Ten., T	tenacity
TGA	thermal gravimetric analysis
yr	year

LIST OF TABLES

<u>Table</u>		<u>Page</u>
I	PBI Single-Stage Polymerizations	14
II	Fractionation of Two-Stage Polymer	20
III	Fractionation of One-Stage Polymer	20
IV	Solutioning Trials with One-Stage Polymer	21
	Solutioning Trials with Two-Stage Polymer	21
V	Dope Stability of Single-Stage Polymer at 100° C	22
VI	Evaluation of Higher Filament Deniers	25
VII	Effect of Steam Stretch on Properties	27
VIII	DMAc Analysis	29
IX	Immersion Washing Trials	31
X	Partial Immersion Washing Trials	33
XI	Effect of Residence Time on DMAc Level	34
XII	Washing of 8100/2970 Yarn	36
XIII	Washing of Various Tow Deniers	36
XIV	Washing of Various Tow Deniers	38
XV	Comparison of Washing Systems	40
XVI	Effect of Residence Time on DMAc Removal	40
XVII	Spinning and Drawing Evaluation of Various I. V. Level Polymers	44
XVIII	Effect of Heating on Yarn Properties	47
XIX	In-Line Drying-Drawing Tirals	48
XX	Dry-Draw of 990 Fil Tow	49
XXI	Evaluation of Continuously Washed Yarn	49
XXII	Effect of Third Hot Shoe	50
XXIII	Evaluation of 1000 Fil Continuously Washed Yarn	50
XXIV	PBI Dope Batches	52
XXV	PBI Spinning Trials	54
XXVI	PBI Draw Study - I	56
XXVII	PBI Draw Study - II	57
XXVIII	PBI Draw Study - III	58
XXIX	PBI Draw Study - IV	59
XXX	Tow Trials - Staged Shoes	60
XXXI	Tow Trials - Identical Shoes	60
XXXII	Tow Trials - Oven Temperature	66
XXXIII	Dope Analysis	67
XXXIV	Effect of Washing and Drying Conditions on Fiber Properties	68
XXXV	PBI Spinning Conditions	69
XXXVI	Effect of Drying Temperature on Undrawn and Drawn Properties - 1000 Fils	70

LIST OF TABLES (CONTINUED)

<u>Table</u>		<u>Page</u>
XXXVII	Tow Process Conditions and Results	71
XXXVIII	PBI Tow Processing Conditions	72
XXXIX	Plant Production Costs	88
XL	Plant Labor, Utility and Service Costs	89
XLI	Labor, Utility and Service Costs	90
XLII	Plant Manpower Requirements	91
XLIII	Plant Capital Estimate	92
XLIV	Plant Equipment List - 1MM lb/yr	93

LIST OF FIGURES

<u>Figure</u>		<u>Page</u>
1	PBI Polymerization Processes	7
2	Steam Generator System	10
3	Salt Cooling Curve	11
4	Simulated Polymerization Run	12
5	PBI Dope Preparation	18
6	PBI Spinning	24
7	Effect of Temperature on Washing	35
8	Continuous Total Immersion Washing Equipment	37
9	Continuous Water Spray Washing Equipment	39
10	PBI Tow Washing System	42
11	PBI Tow Process	43
12	Isothermal TGA	45
13	PBI Fiber Process	61
14	Tow Process - 25 Bobbin Creel	62
15	Tow Process - Continuous Wash System	63
16	Tow Process - Continuous Drying System	64
17	Tow Process - Hot Shoe Drawing System	65
18	Polymerization - 1MM lb/yr PBI Plant Design	81
19	Dope Preparation - 1MM lb/yr PBI Plant Design	82
20	Staple Spinning - 1MM lb/yr PBI Plant Design	83
21	Staple Processing - 1MM lb/yr PBI Plant Design	84
22	Filament Spinning - 1 MM lb/yr PBI Plant Design	85
23	Filament Processing - 1 MM lb/yr PBI Plant Design	86
24	Production Cost - 1 MM lb/yr PBI Plant	87
25	PBI Single-Stage Reactor	106
26	Schematic of the Single-Stage Polymerization System	107
27	Amount of DMAc Extracted from PBI as a Function of Time	115

SECTION I

INTRODUCTION AND OBJECTIVE

Processes for the production of PBI polymer and its conversion to continuous filament yarn were demonstrated under Contracts AF 33(657)-11232 (Technical Report AFML-TR-66-167 Vol. I, June 1966) and AF 33(615)-5403 (Technical Report AFML-TR-68-22, February 1968). The objective of this project was to establish manufacturing methods and processes for the production of lower cost PBI staple fiber. This includes the scale-up of the one-stage polymerization process, increased spinning productivity, and a 5000 filament tow washing, drying and drawing process. The tow process is intended to be continuous in nature. A demonstration will be performed of the new processes by the production of 500 lbs. of usable product. In addition, preliminary plant design and economics will be provided.

This report describes the work performed for the fulfillment of the above objectives.

SECTION II

SUMMARY

The primary objectives of the program have been successfully achieved. Improved processes leading to PBI staple fiber have been further established, and improved economics resulted from process improvements and higher production in all areas.

A great deal of mechanical difficulty was experienced in the scale-up of the single-stage 50-gallon reactor. Since the requirements of this reactor are so extraordinary with respect to temperature and pressure, its scale-up required extensive mechanical development which resulted in major delays in completion. It was initially designed with an electric heating jacket which was found to be inadequate to reach the desired temperature. Therefore, this system was replaced with a molten salt system. Further delays were encountered because of leaks in the reactor jacket and salt tank as well as failures of some of the purchased components of the molten salt system.

It was discovered that cooling the reactor by passing steam or hot water through the jacket resulted in excessive thermal shock which caused cracks in various welds. Therefore, a salt cooling system was installed which consisted of a salt-water heat exchanger (This unit is referred to as a steam generator.). The steam generator was installed and successfully used to cool the reactor from 450 °C to 200 °C in the required time.

Polymer was prepared by the single-stage polymerization process with the target inherent viscosity (I. V.) of 0.70 or higher. The spinning dope from this polymer, however, showed a greater tendency to plug the filter presses although the filtered dope appears to be free of gels. Yarn spun from this polymer was darker in color and exhibited lower properties than previously spun yarns. The high temperatures required for the single-stage process could affect these properties in this way.

The solubility of PBI polymer prepared by the single-stage process in DMAc below the solvent boiling point at 25% solids concentration was sufficient to eliminate the need for pressure solutioning equipment. In addition, stability has been demonstrated with a lithium chloride level of one-half that employed at present with the two-stage polymer. Modifications to the dope reservoir and feed system were made to permit the processing of larger volumes of dope.

An 82% increase in spinning productivity was demonstrated by spinning 200 filament yarns.

Higher filament deniers have also been spun which represent a potential increase in productivity. Some of these variants have been successfully drawn to give target properties.

Yarn was spun with and without steam stretching to further evaluate the need for this processing step. It was found to be unnecessary when the spun yarn is to be processed in a continuous manner.

New jet starting techniques were developed which result in rapid starting. The dope viscosity level was found to have a direct effect on the ease with which the spinning jet can be started and little or no effect on the yarn properties.

An accident in the spinning column resulted in a 6-weeks stoppage of spinning operations. Corrective safety measures were initiated and their effectiveness demonstrated.

A new GC analytical method for determining residual DMAc levels in yarn was perfected. TGA and MS analysis were employed for determining the ease with which DMAc and water may be removed from the yarn. A direct comparison of the two continuous yarn washing systems evaluated indicated that the total yarn immersion method was superior to the water spray. Initial continuous washing trials reduced the residual DMAc level in as-spun yarn from about 13% to 0.1% in 2 minutes. Water temperature and the removal of bubbles on the yarn's surface are important parameters. Acceptable drawn properties on continuously washed yarn having residual solvent levels of 0.13 and 0.25% were obtained by drying and drawing in tandem.

The high moisture regain of PBI made continuous drying studies of PBI washed yarn impractical. In-line continuous drying and drawing demonstrated complete drying with excellent product properties.

A thermal process for the removal of DMAc and water from as-spun yarn (instead of washing) was demonstrated; however, lower elongations were obtained. Either oxidative degradation at elevated temperatures or the effect of the residual LiCl would account for this reduction. This approach will hold promise if the one-stage polymer is more stable in solution than the present polymer or LiCl can be eliminated at some future time.

Shrinkage forces, apparent on washing and drying the spun yarn, were measured. These forces were appreciable and their due consideration was made in the design of the tow process equipment. The process equipment for the tow including the washing, drying, and drawing assemblies was designed and constructed. Preliminary shake-down trials of the tow line were successful when target properties were obtained at target speed with a 1000 filament tow on the first run.

Because of insufficient time to establish fully the single-stage polymer process conditions to yield acceptable dope and yarn reproducibly, two-stage polymer was utilized in the remainder of the tow demonstration. The polymerization, dope preparation, and spinning operations were performed for the tow demonstration without difficulty. The spun yarn was taken up on 5.5-lb. packages without steam stretch.

Scale-up from 1000 to 5000 filaments on the tow line was performed with conditions being obtained at each level to yield target properties. Stability of processing was found to be dependent upon the speed and the size of the tow up to the temperature limits of the shoes. The 500 lbs. of tow was processed at the 4000 to 5000 filament level. The lot average properties were 1.49 dpf, 4.16g/d tenacity, and 22.8% elongation.

A total of 470 lbs. of staple fiber and 30 lbs. of tow were shipped in agreement with the Contract Project Engineer.

A preliminary plant design incorporating the demonstrated processes resulting from this program was prepared for a 1MM lb/yr. battery limits PBI plant. A product line of 0.8 MM lb/yr. staple fiber and 0.2MM lb/yr. continuous filament yarn was assumed. A production cost of \$7.56/lb overall resulted when DAB and DPIP costs are \$5.00 and \$1.00/lb. respectively. DAB costs account for two thirds of the production cost at that level.

SECTION III

DISCUSSION

1. RAW MATERIALS

The raw materials required to obtain the engineering data needed to design and establish satisfactory manufacturing methods for production of PBI tow and staple are listed below:

Phenol	200 lbs.
DAB	1,475 lbs.
DPIP	2,200 lbs.
DMAc	6,000 lbs.
Nitrogen	300,000 cu. ft.
Lithium Chloride	160 lbs.
Yarn Lubricant	100 lbs.
Filter Dressings	14 sets
Yarn Bobbins	500 ea.

Of particular importance are DAB (3,3'-diaminobenzidine) and DPIP (diphenylisophthalate). These two monomers are the principal ingredients of the PBI polymer and neither is as yet readily available at the quality level needed for fiber production. However, using the purification technology established under AF 33(657)-11232 and AF 33(615)-5403, one supplier had the capability to make "fiber grade" DAB to our specifications.

The supplier of the diphenyl isophthalate had advised us that approximately 50% of the order contained a higher level of diphenyl terephthalate. The degree of contamination and its effect, on the polymerization process was examined. Analysis by gas chromatography (GC) disclosed a diphenyl terephthalate impurity level of about 0.8% plus 1.7% of an unknown impurity. A review of previously used material showed the presence of the same impurity at about the same 1.7% level. Acceptable polymer was prepared from both the DAB and DPIP monomers. On the basis of this data, no difficulty was anticipated with their utilization in the scale-up of the single-stage polymerization process.

2. POLYMERIZATION

a. Historical Background. The feasibility of a one-stage polymerization process was demonstrated during a previous contract. In contrast to the presently used two-stage process, the reactants in the one-stage are polymerized under autogenous pressure in a closed reactor in one step by uninterrupted heating to the maximum temperature. This is followed by depressurization and a post heating

period. After cooling, the polymer is discharged without difficulty as a free-flowing powder.

The elimination of the foaming step encountered in the two-stage process is apparently accomplished by retaining the water and phenol by-products in a 1:1 ratio. This decreases the viscosity of the melt. As the polymer reaches a sufficient molecular weight, it apparently precipitates out in the form of fine particles.

The comparison of the present two-stage process and the one-stage process that was scaled-up is depicted in Figure 1. The cycle times do not include the cooling stage which in itself is substantial. Two 60 lb. charges from the 150 gal. reactor are required for one run in the 50 gal. reactor. The conditions for the one-stage pressure process are given on the right. These process conditions were defined for producing high I. V. (0.9) PBI polymer in the one-gallon autoclave. This process offers many advantages over the two-stage process including reduced capital and labor expenditures as well as improved operating procedures. Investigation of the polymerization parameters and character of the one-stage polymer indicated that crystallinity is formed during the polymerization under pressure which is extremely stable. Temperatures as high as 450°C (60°C higher than employed in the alternate process) were required to drive the reaction to completion.

b. Scale-Up Objectives. Scale-up of the one-stage process during a previous contract in the present 50-gallon oil heated reactor resulted in low I. V. (0.6) polymer due to equipment malfunctions and the limitations of the hot oil system in obtaining the required temperature. An objective of this program was to scale-up this process in an electrically heated 316 SS 50-gallon pressure reactor capable of 500 psig pressure at 500°C. Its operation would represent a 50-fold scale-up of the demonstrated bench-scale process.

c. Process Equipment and Shakedown. The reactor, heating assembly, and support stand were specially designed for this process. The installation of the 50-gallon single-stage polymerization reactor was completed after some difficulties were encountered with the initial delivery, installation, and check out of the major components of this system. To correct a heat-up deficiency, the heating jacket was returned to the vendor for modifications. The piping, was found to require extensive welding in order to prevent leaks at the fittings between the head and each of the high pressure valves. Due to the specific pressure requirements of this process, such leakage could not be tolerated. During the check-out for operability, the anchor-type agitator was found to rub against a thermowell. This

FIGURE 1

PBI POLYMERIZATION PROCESSES

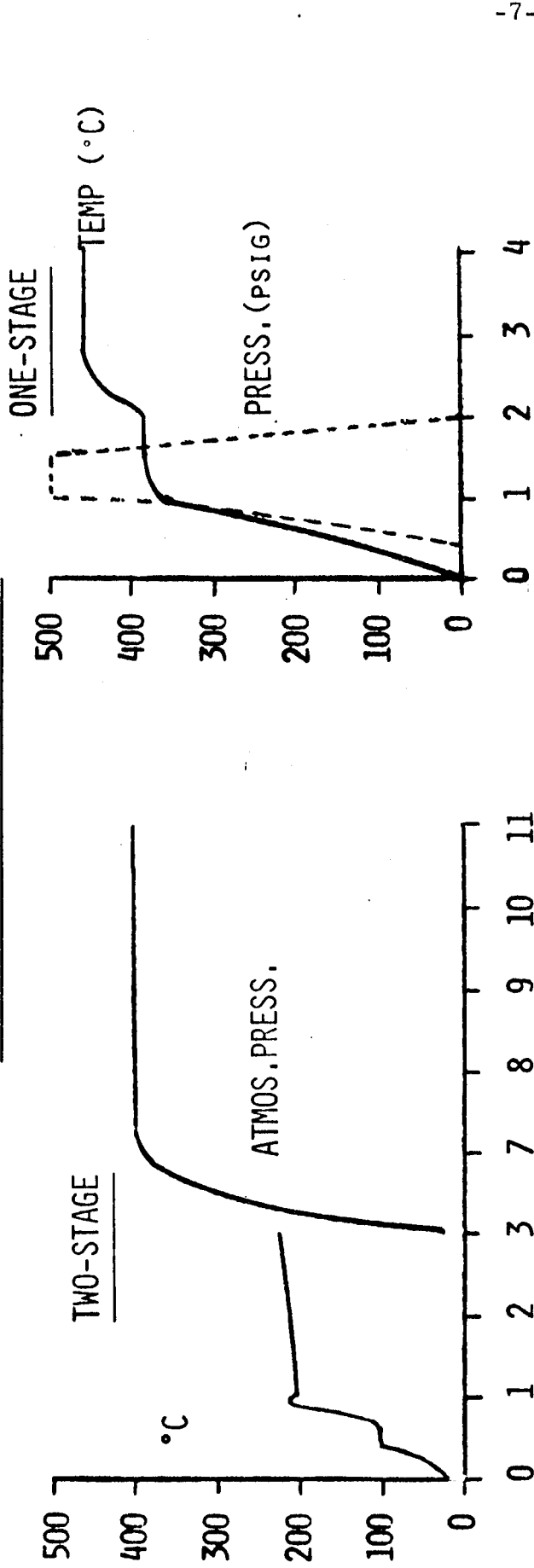

HOURS

HOURS

150 & 50 GAL. HOT OIL HEATED REACTORS

50 GAL MOLTEN SALT HEATED REACTOR

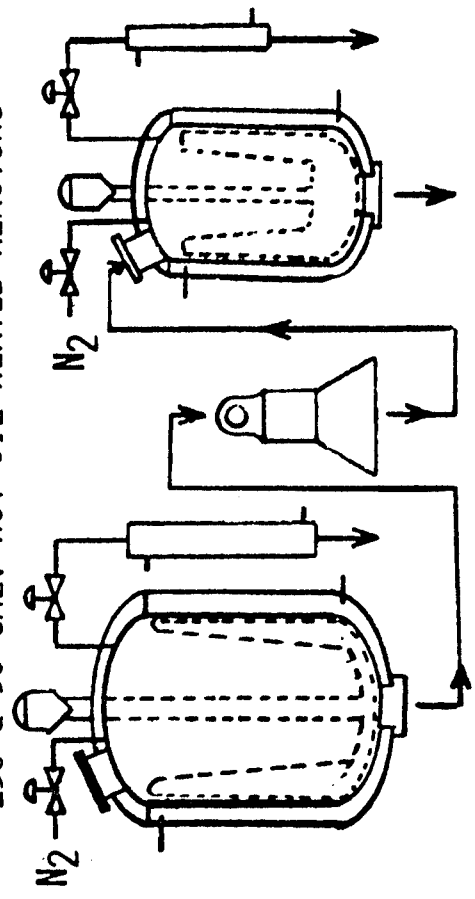

PREPOLYMER (LUMPS)

POLYMER (COARSE POWDER)

POLYMER (FINE POWDER)

condition was corrected by grinding off a small amount of the thermowell.

The heat-up deficiency became apparent during the initial heating trial, utilizing the 2 KW head heater and 13 KW body heater. Even though the reactor flanges and piping were not insulated, the heat-up rate was slower than expected. To increase this rate, additional heaters (8 KW for the head flange and 2.5 KW for the bottom discharge flange) were installed. Also, a high-pressure steam line was added, giving the coil covering the body of the reactor the dual functionality of heating and cooling. In this way, the vessel could be heated rapidly to 190°C with steam and brought to the necessary reaction temperatures with the electrical heaters.

The heating system was still found to be inadequate for reaching the required 500°C temperatures in a reasonable length of time. A redesign of the lower section was made. To supplement the existing heaters, a molten salt system was added. This included the attachment of a jacket to the lower body of the reactor. This new system is capable of supplying 100 KW of heat. The existing 2 KW head heater, 8 KW head flange heaters, and 2.5 KW bottom discharge flange heaters were retained giving a total system equivalent to 112.5 KW. The sensors and controls provided originally served for the salt system.

Fabrication of the jacket for the lower shell of the 50-gallon single-stage reactor was delayed when it was discovered that the steel being used was not of the type specified. After this situation was corrected, the jacket was installed. A late delivery of the molten salt system also caused a slippage in the installation schedule. It was also realized that certain safety features had been omitted from the molten salt system controls which are recommended for routine use with molten salt. These were then provided.

After the reinstallation of the 50-gallon single-stage reactor and the molten salt system, the initial heating trials were successful with the attainment of 450°C. However, this system became inoperative after the third heating trial. The salt pump was dismantled and found to have inadequate bearings and packing. This caused it to fail at the specified operating temperatures (450°C). In addition, the steam tracing on the salt lines was not sufficient to prevent the solidification of residual salt in the valves. New bearings for both the main pump and the spare pump and special valve heaters were fabricated and installed. Other difficulties encountered included salt system control and thermocouple failures connected with the fail-safe features of the original equipment. These were all corrected.

Further difficulties with the new single-stage reactor and salt system were encountered causing further delays in this program. The molten salt was directed to the reactor jacket at 400°C as per the use of the hot oil with

the previous reactors. After a few such trials, a crack appeared in a jacket weld requiring extensive rewelding and testing. In addition, the junction between the two salt tanks tore apart causing the molten salt to leak on the floor. The pump, piping and top of the sump tank were dismantled and the junction was re-welded.

Subsequent trials with the salt directed to the reactor at 250°C were successful without any leakage. The empty reactor was heated and found to reach 450°C in four (4) hours, a rate less than expected for the rated heating capacity. Amperage readings indicated a 50% level and the vendor's wiring was found to be in error. Following rewiring, the system was tried and temperature was reached in one hour and forty minutes which is quite acceptable. With the reactor at 450°C and controlling at one-quarter power, the temperature could not be maintained.

A separate controller was then provided to allow control on full power. This system performed well after some additional wiring problems. A steam generator had been purchased and was installed for cooling the reactor and salt down to about 225°C followed by water cooling in the coil attached to the reactor shell. Without this unit, the cooling rate would be too slow leading to cross-linked polymers. Such a polymer would be insoluble in the spinning solvent. The reactor and associated piping were then re-insulated.

The steam generator system as shown in Figure 2 consists of the water tank (T-4) which supplies the steam generator (T-5) with water on demand by the use of a liquid level controller. The molten salt from the sump tank enters a coil in the base of T-5 and generates controlled steam pressures of 120 to 150 psig. After the salt exits at the top of T-5, substantially reduced in temperature, it enters the reactor jacket. When the salt system has been cooled to 200°C, the lines are drained of salt to prevent solidification. Steam is then passed through the coil welded to the side of the reactor followed by water to complete the cooling cycle.

The initial trials with the steam generator were successful as shown by the cooling curve in Figure 3. The empty reactor was heated to 450°C. The salt was then directed to the reactor by way of the steam generator. The piping is such as to simultaneously cool the reactor as well as the salt system, bringing the bulk of the salt to 200°C in preparation for a subsequent run. The elapsed time was 45 minutes to cool from 450°C to 200°C.

A simulated run was performed to obtain processing data and to test the proposed operating procedures. The charge consisted of 42 lbs. of single-stage polymer (I. V. = 0.60, prepared in the oil-heated reactor), 80.75 lbs. phenol, and 5.85 lbs. of water. The process cycle is shown in Figure 4.

FIGURE 2

STEAM GENERATOR SYSTEM

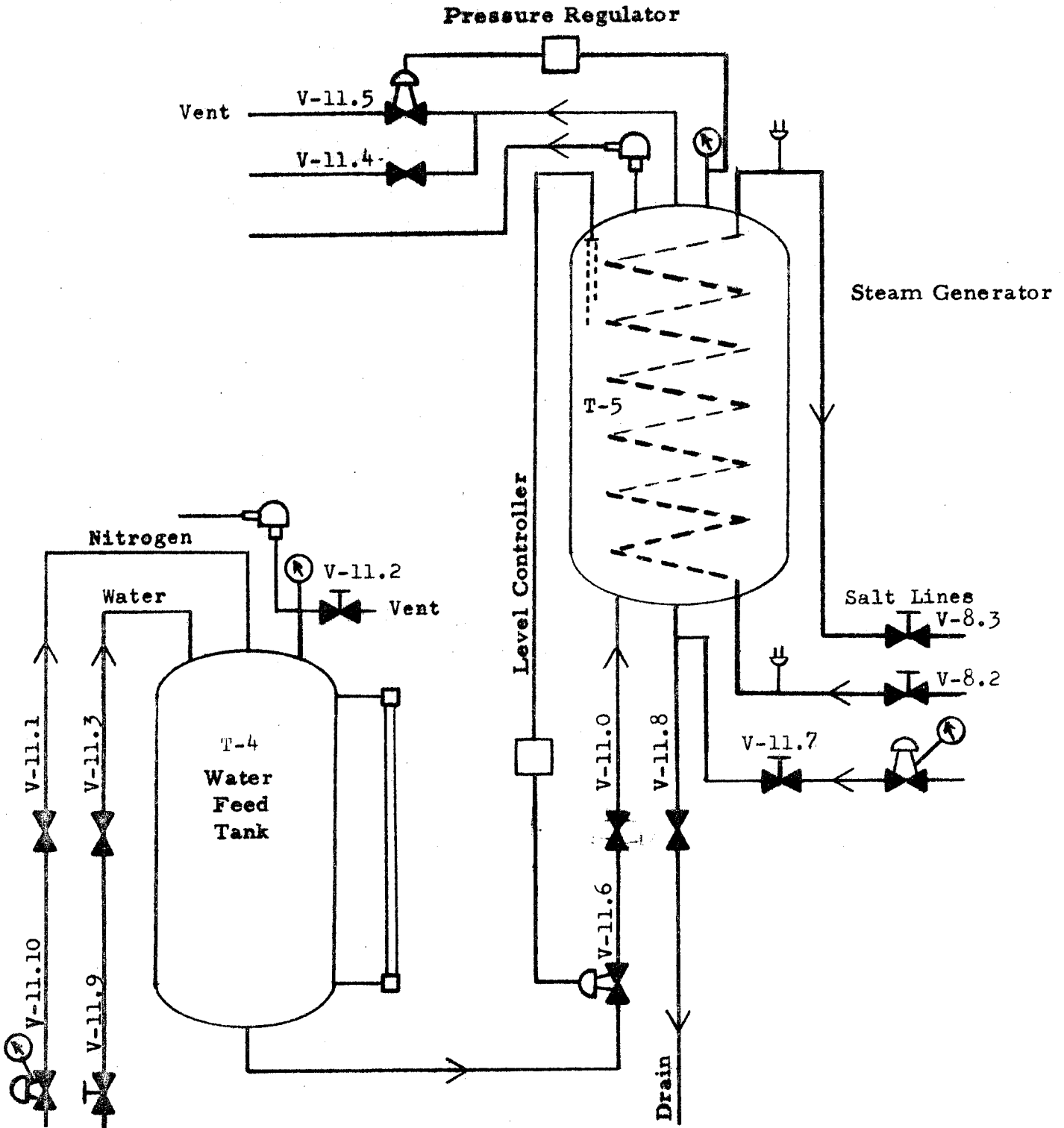

FIGURE 3

SALT COOLING CURVE

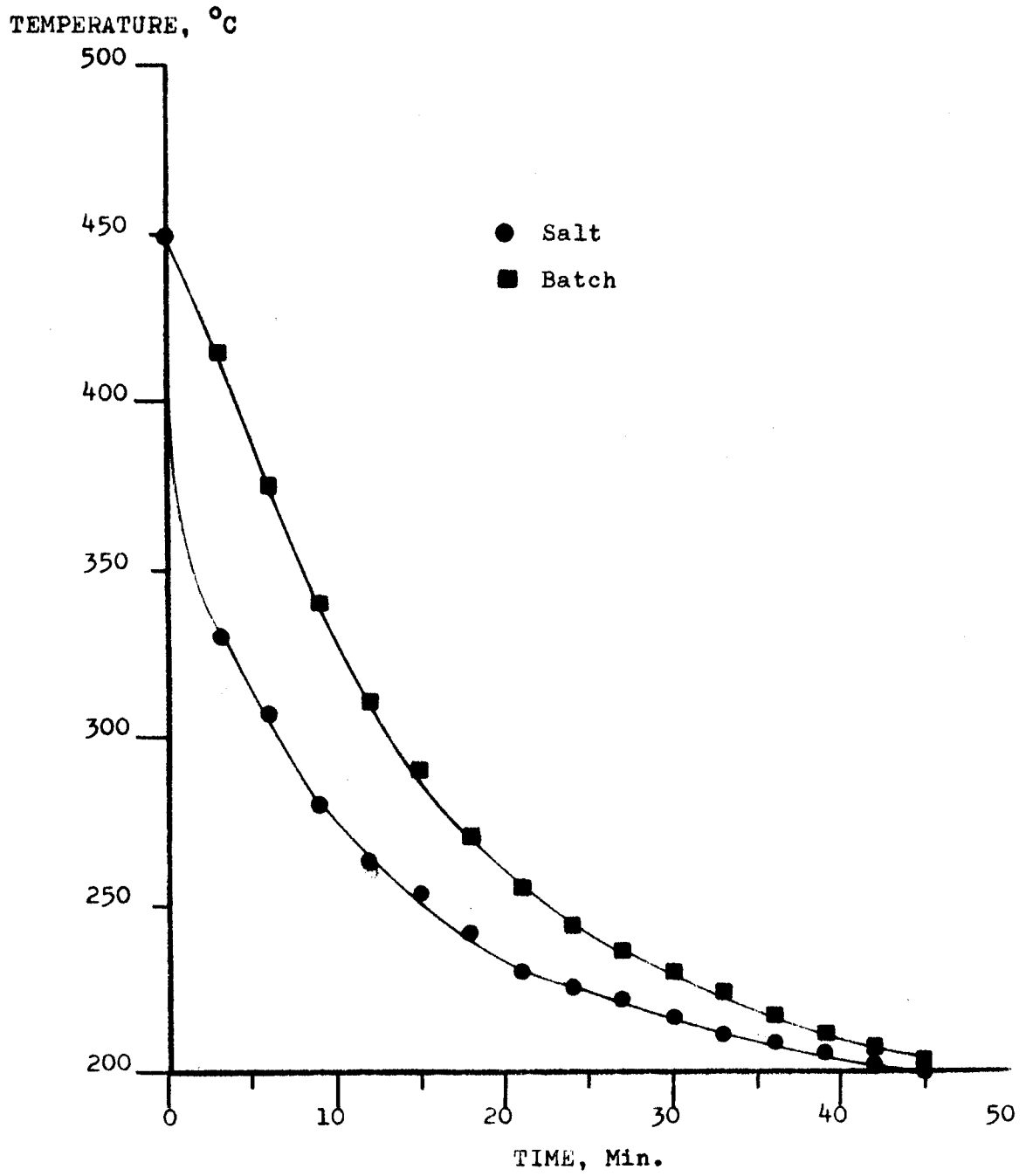
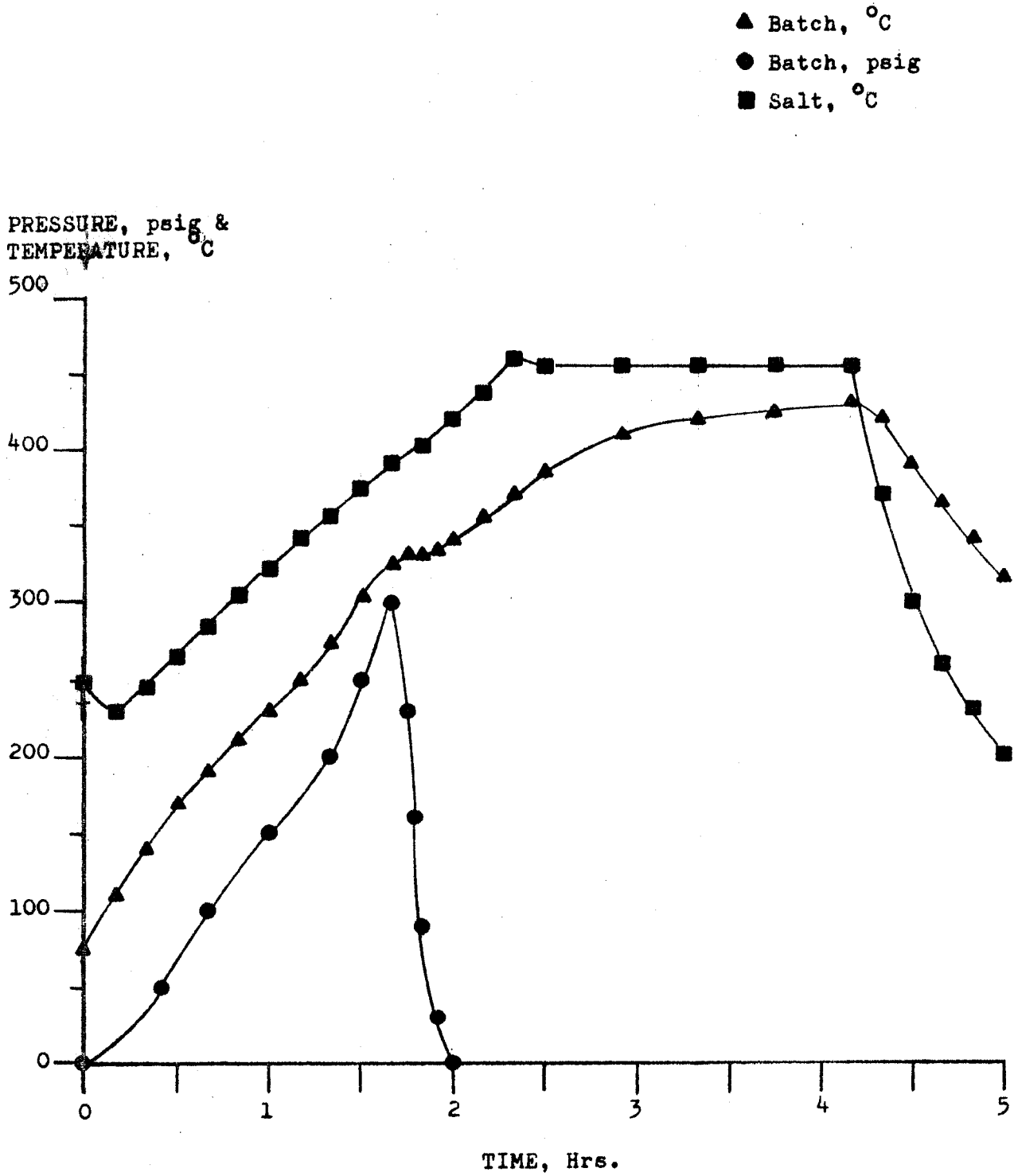

FIGURE 4

SIMULATED POLYMERIZATION RUN



The I.V. was advanced to 0.69 with a two-hour salt temperature of 455° C.

Minor difficulties were encountered with the simulated run. A number of leaks releasing obnoxious phenol vapors were detected under the head heater. The temperature of the head was lower than expected resulting in a lower pressure prior to venting. To resolve these problems, the head heater was removed and all of the pipe fittings to the head were welded. The 2-KW head heater was replaced with a set of heaters totaling 7.2 KW.

d. Polymerization Process Development. Polymer has been successfully produced by the single-stage polymerization process in the 50-gallon reactor. The target I.V. of 0.70 or greater was achieved with the third polymerization run. The twelve polymers produced so far are tabulated in Table I. The first two runs were at a charge level of 1.0 lb/gal, which exceeded the two-stage prepolymer level of 0.4 lb/gal. The next nine runs were at an increased charge level of 1.5 lbs/gal with the last run at 2.0 lbs/gal. Standard operating procedures are given in Appendix I as well as a schematic diagram and picture (Figures 25 and 26) of the process equipment. Since run P-902 had given target properties, runs P-907 thru P-910 were made by duplicating the former's conditions with minor modifications.

Difficulties with the equipment continued to plague the operations. The agitator blade scraped against the wall after the first run causing a termination of agitation on cooling. The reactor head was pulled and the agitator's edge was ground to provide additional clearance. No further difficulties with agitation occurred during the heating cycle but some contact with the reactor wall continued during the cool-down cycle. A reduction in the initial cooling rate reduced the contraction of the wall to the agitator blade and eliminated the agitation difficulty during this cycle.

The molten salt leaked through the gate valves to the steam generator twice with solidification in the non-heated lines. Replacement plug valves and an electrical tracing system for heating the salt piping have been installed to prevent this from re-occurring. The one-inch half-pipe welded to the reactor shell for preheating and final cooling with steam and cold water, respectively, separated at the weld causing a small amount of water to seep into the salt system which generated steam. The leakage was identified by the 100°C temperature observed on the thermocouples in the salt lines. The coil and salt lines were both drained of accumulated water and the coil was sealed off prior to the next run.

The original packing in the agitator gland failed in the third run causing phenol vapors and liquid to leak out of the reactor during the pressure cycle. A

TABLE I
PBI SINGLE-STAGE POLYMERIZATIONS

<u>Polymer Batch</u>	<u>Polymer¹ Level, lbs</u>	<u>Phenol² Charged, lbs</u>	<u>Pressure³ Max, psig</u>	<u>Post-Heat⁴ Hrs/RPMs</u>	<u>Batch Max °C</u>	<u>Salt Max °C</u>	<u>Polymer⁵ I. V.</u>
P-900	50	S-50	400	2/50	443	466	0.63
P-901	"	C-11	350	3/"	453	477	0.66
P-902	75	S-50	400	4/55	454	480	0.73
P-903	"	" "	"	" /60	466	482	N.S.
P-904	"	C-38	"	3/"	463	484	N.S.
P-905	"	" "	"	2/"	445	484	0.53
P-906	"	S- "	250	1.5/55	440	482	0.53 ⁶
P-907	"	"-50	400	4/55	454	481	0.78
P-908	"	C- "	"	" /"	457	483	0.89
P-909	"	" -"	"	" /"	457	482	0.79
P-910	"	" -"	"	3.7/55	452	483	0.71
P-911	100	C-66	400	4/55	463	483	0.78

- (1) monomers charged to yield this polymer level.
- (2) straight (S) phenol or reaction condensate (C) charged with the monomers.
- (3) maximum pressure reached
- (4) time after venting with nitrogen sweep/agitator speed
- (5) 0.4 g/dl in 97.0 ± 0.1% sulfuric acid; not soluble (NS)
- (6) lower batch temperature on venting resulted in a subsequent shut down of the agitator and early termination of the run.

superior resilient replacement packing rated for hydrocarbons at high temperatures and pressures was selected which has demonstrated excellent performance since its installation.

The water level controller on the steam generator malfunctioned in a number of runs requiring manual filling. Bumping and splashing of the generator's contents apparently resulted in the failure, and additional baffling of the sensing probes overcame this problem. A reworking of the water feed system will be performed in the near future.

A one-eighth inch hard crust of baked polymer was observed on the reactor wall after each run. While scraping the inside wall is feasible with this reactor, it would not be feasible in a commercial operation. In an attempt to reduce this build-up, the depressurization cycle was altered in the latter runs reducing this build-up to about one-sixteenth inch.

e. Polymer Characterization and Evaluation. An analytical comparison of the single-stage and two-stage polymers was performed. No appreciable differences have been observed in the moisture, phenol or oxygen levels. Neither induced electron emission or probe-mass spectrographic analysis showed any differences in the polymers with respect to nitroso or other nitrogen derivatives. Infrared analysis supports the crystallinity of the single-stage polymer as previously observed by wide angle x-ray diffraction analysis. The crystallinity, however, is destroyed on solutioning.

The effect of the moisture content of the single-stage polymer on I. V. and dope viscosity was examined and found to be negligible. Samples of polymer were vacuum dried at 105°C or exposed to the atmosphere for 16 hours with resultant I. V. 's of 0.77 and 0.75, respectively, indicating very little effect of moisture on the I. V. A duplicate controlled solutioning study was performed in which the polymer and LiCl were dried and then dissolved in anhydrous DMAc with water being added to the second flask to a level of 0.5 weight percent on the total solution. No effect was observed since the dope viscosities varied by only 2%.

A comparison of single-stage polymers having identical I. V. 's from the one-gallon autoclave and the new 50-gallon reactor was made by solutioning them in glassware. The latter polymer exhibited a slightly higher degree of insolubility and darker color. The color is significant in light of the darker yarns recently produced from the single-stage polymer. The viscosities differed by 15% indicating again less solubilization of the 50-gallon polymer; but both samples demonstrated a much lower level than would be achieved by its two-stage counterpart. This was also observed in the large scale equipment.

The insoluble portion of the polymer was examined by removing the residue from the filter press and rinsing it with DMAc. An I. V. could not be obtained as it was completely insoluble in concentrated sulfuric acid. It is probably a highly cross-linked polymer resulting from the high temperatures required by the process.

A filterability test such as dope plugging value was desirable in order to make comparisons between the polymers. Samples of dope from single-stage and two-stage batches were examined by diluting from 24% down to 6.9% and filtering with a buchner filter and a 9 cm No. 1 Whatman filter paper. The two-stage dope passed nearly twice as much filtrate before plugging indicating again the observed differences between the two polymers. The standard procedures for P. V. 's on the polymer in sulfuric acid may be modified to permit running P. V. 's with DMAc, since the solubility characteristics of the polymers in sulfuric acid seems to be reversed and not as meaningful.

A check on the polymer I. V. used in the large scale dope preps and the I. V. 's from polymer precipitated from the filtered dope, as well as the spun yarn I. V., demonstrated a fine correlation with no apparent change throughout the process as shown below:

<u>Polymerization Process</u>	<u>Polymer I. V.</u>	<u>Dope I. V.</u>	<u>Yarn I. V.</u>
Single-Stage	0.83*	0.82	0.82
Two-Stage	0.86	0.83	0.84

* Average of 4 batches.

f. Production. Because of the continuing difficulties with the single-stage polymer, the polymer required for the demonstration run was made by the two-stage process without difficulty. The average I. V. level of 0.87 ± 0.03 demonstrated fine reproducibility.

3. DOPE PREPARATION

a. Process Description. The dope preparation equipment at the start of this program consisted of a solutioning vessel and two holding tanks, each with a pump and filter press. Auxiliary equipment includes a polymer scale, a DMAc-LiCl make-up take, a DMAc holding tank and meter, a walk-in hood for complete enclosure of filter

presses, cleaning equipment, and pumping and recirculation equipment.

The dope is prepared by charging 15.9 gals. of DMAc containing 2.0% LiCl to the 30 gal. mixer. Then 40 lbs. of polymer is added with agitation. The vessel is purged with nitrogen and then heated to 240°C at 80 psi pressure and held for two hours. The batch is then cooled to about 140°C and pumped to the first holding tank, the 20-gallon mixer. Further cooling occurs during transfer with the final temperature being close to the 100°C holding temperature. The 20-gallon and 100-gallon jacketed holding tanks and associated jacketed filter presses are all heated with low pressure steam. The standard filter dressing includes 30-ply Kimpak, 1/4-inch polypropylene felt, and Canton flannel.

After 20-24 hours filtration through the 18" press, in the first filtration stage, the dope is pumped to the 100 gallon holding tank. The dope is then continuously filtered through the 10" press and directed to the top of the spinning columns where the required quantity is withdrawn with the balance returning to the 100 gal. vessel.

b. Equipment Modifications. The dope preparation system was modified to permit higher throughputs required by higher filament counts and deniers that were spun during the demonstration period. This included the enlargement of the storage capacity of each filtration stage and the installation of remote dope pressure gauges for better control of the pressure throughout the system. Piping to the 150 gal. polymer reactor was also completed for its potential use as a solutioning vessel. This system is depicted schematically in Figure 5. This system has been used under production-like conditions with two columns in use simultaneously. This test demonstrated that the dope preparation system has the desired supply capability.

It is reasonable to conclude, then, that pressure solutioning equipment should no longer be required in dope preparation, neither in our pilot facilities nor on a full commercial scale. This would result in an appreciable savings of capital costs. Equipment designs to exploit this solubility feature of the single-stage polymers have been considered.

The stability of the above samples at elevated temperatures was then examined since the dope system is maintained at 100°C during the spinning operation. The results of these tests are discussed below.

c. Solubility of One and Two-Stage Polymers. Polymers from both processes yield practically identical I. V., plugging values (P. V.), TGA curves, elemental analysis, and infra-red spectra. However, they do possess different solubility

FIGURE 5

PBI DOPE PREPARATION

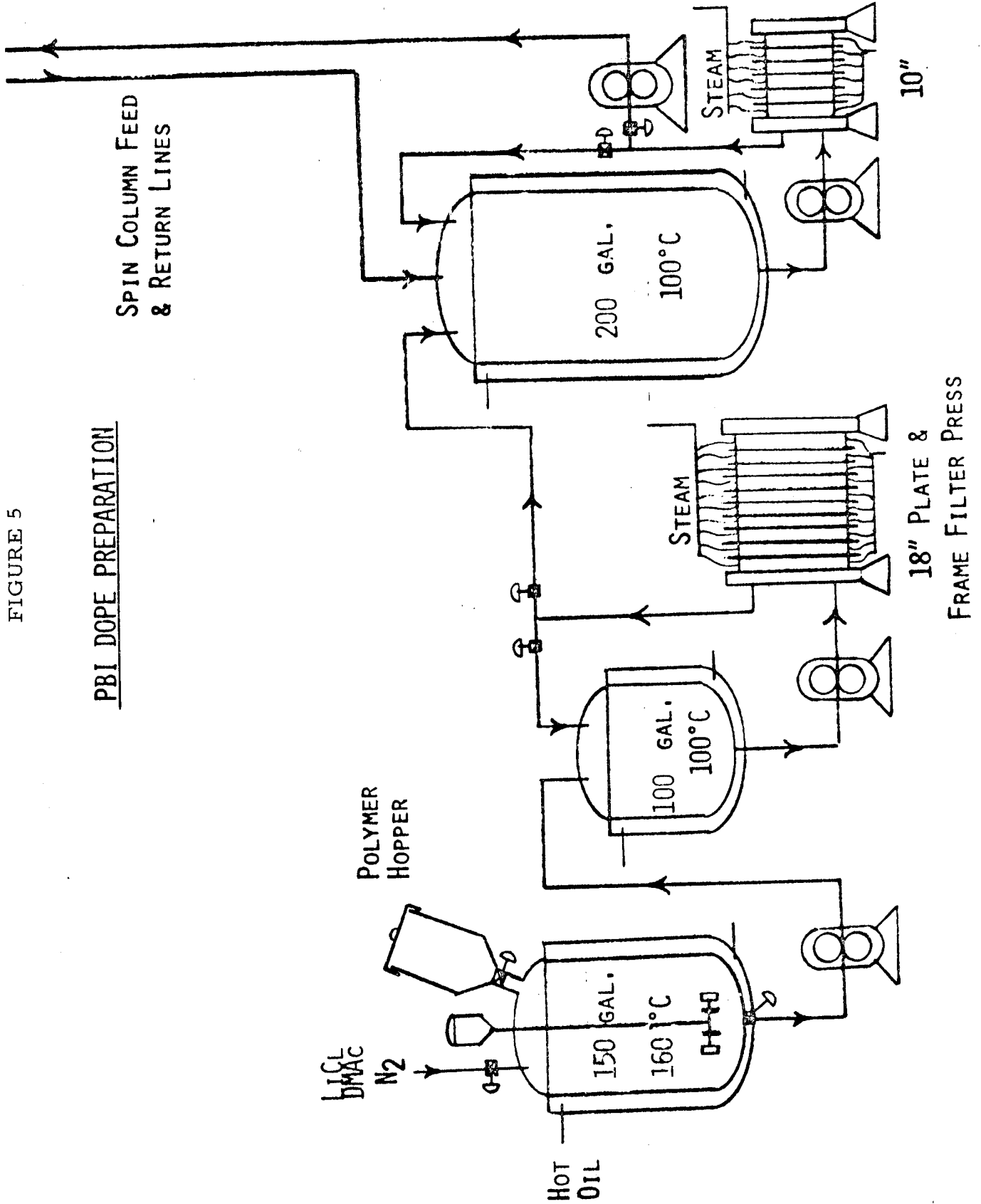

characteristics. The one-stage polymer is considerably more soluble in DMAc than the two-stage counterpart. This difference may be a result of the physical form of the one-stage polymer. It could also be the result of a narrower molecular weight distribution, as discussed below.

The findings of molecular weight fractionation studies performed under Contract AF 33(615)-5403 are summarized in Tables II and III for polymers of similar I. V. levels from both processes. Since the spread of the separated fractions of the two-stage polymer is much greater than the one-stage polymer, it may be concluded that the latter has either a much narrower molecular weight distribution and/or a more uniform particle size.

These solubility determinations were conducted at solids concentrations of 15%. This is some 8 to 9% below the normal dope concentration required for spinning. Additional solubility determinations were therefore performed to demonstrate that the one-stage polymer can in fact be solutioned below the boiling point of the solvent at solids concentrations as high as 25% (1 to 2% above normal).

The solutioning trials shown in Table IV were performed with 50 grams of polymer, 150 grams of DMAc, and either 1.5 grams (1%), or no lithium chloride (LiCl). The normal LiCl level is 2.0% by weight of the spinning solvent.

The solutioning apparatus consisted of a typical three-necked 500 ml round bottom pyrex flask fitted with a turbine agitator, condenser, and nitrogen sweep. The effectiveness of this type of agitator is judged to be below that of the anchor type in the 150 gal polymer reactor.

The one-stage polymer (0.6 - 1.2 I. V.) required 3 to 9 hours of heating above 100°C to solution. However, the two stage polymer (0.91 I. V.) was still not in solution after 34 hours. Note the relationships between molecular weight (by I. V.) and % lithium chloride with the dope viscosity.

d. Dope Stability. During the early development of dope preparation procedures a phasing out phenomenon was encountered. After standing for some time, a precipitate would come out of the spinning dope, forming an opaque crystalline paste. Water content and temperature of storage were shown to affect stability, but phasing out still occurred in a matter of days. This phenomenon was thermally reversible, with complete resolution occurring at 140°C. The problem was solved by an extensive additive study which showed that lithium chloride at the 1% level (by weight of DMAc) stabilized the dopes for periods in excess of 30 days. A safety factor was included, and 2% lithium chloride was made the standard procedure.

TABLE II

FRACTIONATION OF TWO-STAGE POLYMER*

<u>Extracting Solvent</u>	<u>Temp. °C</u>	<u>Time hrs.</u>	<u>Soluble</u>		<u>Insoluble</u>	
			<u>%</u>	<u>I. V. **</u>	<u>%</u>	<u>I. V. **</u>
DMAc	140	2	74.4	0.63	25.6	1.25
DMAc	140	4	77	0.63	23	1.28
DMAc	70	2	7.7	0.62	92.3	0.84
DMAc	70	4	11.9	0.55	88.1	0.81

* Polymer I. V. = 0.78

TABLE III

FRACTIONATION OF ONE-STAGE POLYMER*

<u>Extracting Solvent</u>	<u>Temp. °C</u>	<u>Time hrs.</u>	<u>Soluble</u>		<u>Insoluble</u>	
			<u>%</u>	<u>I. V. **</u>	<u>%</u>	<u>I. V. **</u>
DMAc	140	2	99	0.73	0.5	-
DMAc	70	2	99	0.74	0.5	-
DMAc	23	2	50	0.74	50	0.78
95% DMAc/ 5% H ₂ O	23	2	19	0.74	81	0.74
80% DMAc/ 20% H ₂ O	23	2	13.5	0.62	86	0.73

* Polymer I. V. = 0.74

** I. V. = inherent viscosity as g/dl; from where $c = 0.4$ g/dl of 97.0 ± 0.1% H₂SO₄ @ 25°C.

TABLE IV

SOLUTIONING TRIALS WITH ONE-STAGE POLYMER

at 160°C

<u>Run No.</u>	<u>I. V.</u>	<u>% LiCl</u>	<u>Dope Viscosity⁽¹⁾</u>
1	0.60	0	6,400
2	0.85	0	53,000
3	0.85	1	124,000
4	0.94	0	96,000
5	1.20	0	120,000
6	1.20	1	400,000

WITH TWO-STAGE POLYMER

at 160°C

7	0.88	1	32,000 ⁽²⁾
---	------	---	-----------------------

(1) Brookfield, centipoise.

(2) Sample not completely dissolved after 34 hours of heating.

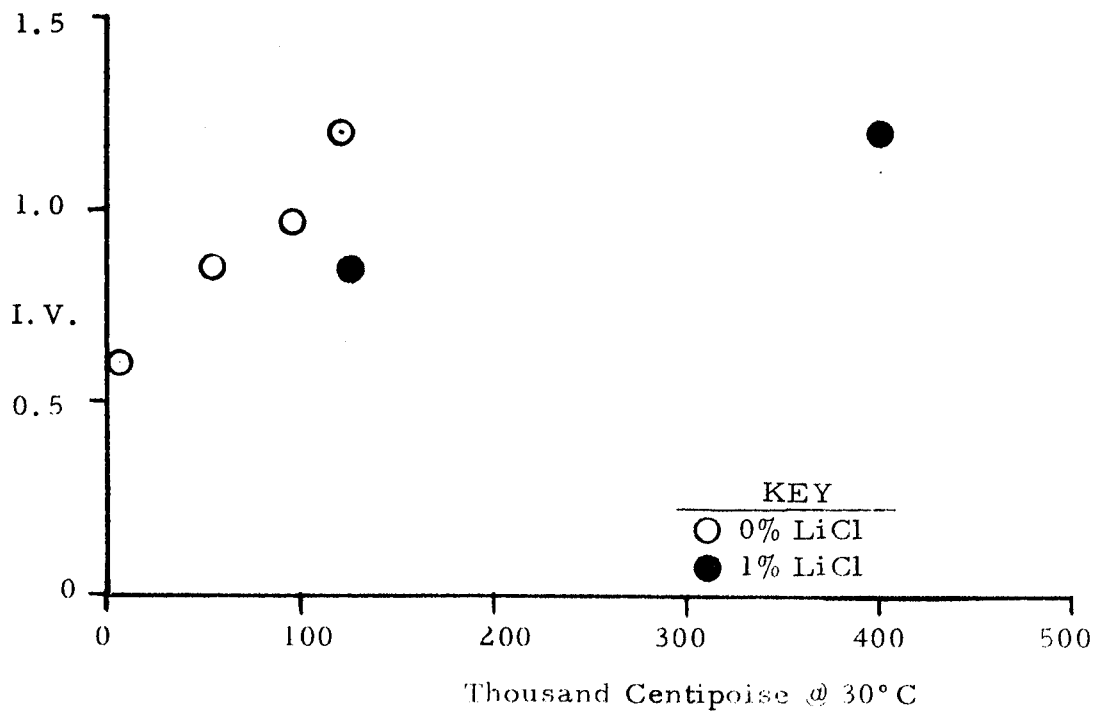

It would appear that the dope stability problem is two-fold. As mentioned earlier, phasing out of the dope is accelerated by high water content. In addition, the high temperature of the present solutioning method facilitates hydrolysis and degradation of the dimethyl acetamide, the products being acetic acid and dimethyl amine. Dimethyl amine also accelerated phasing out.

It can be expected then, that the solutioning of the one-stage polymer at lower temperatures will improve the stability of the resultant dope. In addition the different molecular weight distribution may in itself improve stability. The need for 2% LiCl in the dope will be re-examined as this results in approximately an 8% residue in the spun fiber which must be removed by washing. An alternate thermal process for the removal of DMAc from spun yarn would be possible if LiCl could be eliminated.

Samples of spinning dope were examined for solution stability at 100°C under a nitrogen atmosphere as shown in Table V.

TABLE V
DOPE STABILITY OF SINGLE-STAGE POLYMER AT 100°C

<u>Polymer I. V.</u>	<u>LiCl , %</u>	<u>Stability</u>
0.60	0	Unstable at 12 weeks.
0.88	0	Unstable at 2 weeks
0.88	1	Stable after 26 week.
0.88	2	Stable after 26 weeks
1.20	1	Stable after 26 weeks

These results suggest that a reduction from the 2% LiCl level presently used in preparing the spinning dope may be possible, which would marginally reduce the cost of this operation. Additional discussion on dope preparation appears in a later section entitled DEMONSTRATION.

4. SPINNING

a. Process Description. PBI fiber is dry spun from a 23 to 24% solution in DMAc. This is represented graphically in Figure 6. The spinning solution enters into a heated down draft column. Nitrogen gas is used as the column atmosphere to minimize polymer oxidation and inhibit the flammability of DMAc/air mixture. The nitrogen is recycled after DMAc condensation. The yarn is taken up at 282 m/min, stretched 6% through an atmospheric

pressure steam tube, packaged on perforated bobbins at 300 m/min, and pressure washed to remove the remaining DMAc and LiCl.

During the early work, it was found that a steam stretching operation was necessary to organize the structure for hot drawing and thereby develop the highest level of final properties. At that time, the spinning, steam stretching, and hot drawing operations were all separate, with a washing operation after spinning to remove the residual DMAc solvent.

Problems were encountered at that time because, while washing as a package, the yarn would extend spontaneously on the bobbin and would tend to fall off. The combining of the spinning and steam stretching into single tandem operation eliminated this problem. In addition, it eliminated the need for a separate stretching and packaging operation, and provided a slight advantage in physical properties over the original method. This method was adopted during the early stage of development and has been used throughout the rest of the project.

b. Physical Testing. All physical testing data generated and reported within this program was obtained by averaging the testing results from five single fiber tensile specimens on an Instron Tensile Testor. The results from each break were tabulated on an in-line computer as well as plotting of the stress-strain curves. The average, standard deviation and compliance factor are automatically obtained and printed out for each property desired. A gauge length of one inch and crosshead speed or strain rate of 100% (one inch) per minute were employed in all cases.

c. Filament Deniers. PBI fiber for use as staple has been previously spun in 110 filament bundles at 300 m/min with a denier of 300 (2.7 dpf). This yarn is then drawn at a 2:1 draw ratio to give 150 denier (1.35 dpf) which after crimping, cutting and conditioning to its natural moisture regain level, reaches the 1.5 dpf target. (Note that all spun deniers are on a dry basis and drawn deniers are on a conditioned basis).

Special one to two pound packages of larger denier yarns were prepared including 450/110 (yarn denier/number of filaments), 600/110, and 800/110. The 600/110 yarn was also spun at 300 m/min which is the present maximum speed of the takeup unit. This represents a 100% increase in productivity if a heavier yarn can be drawn at higher draw ratios to give acceptable properties. The ability to spin higher deniers was apparently

FIGURE 6
PBI SPINNING

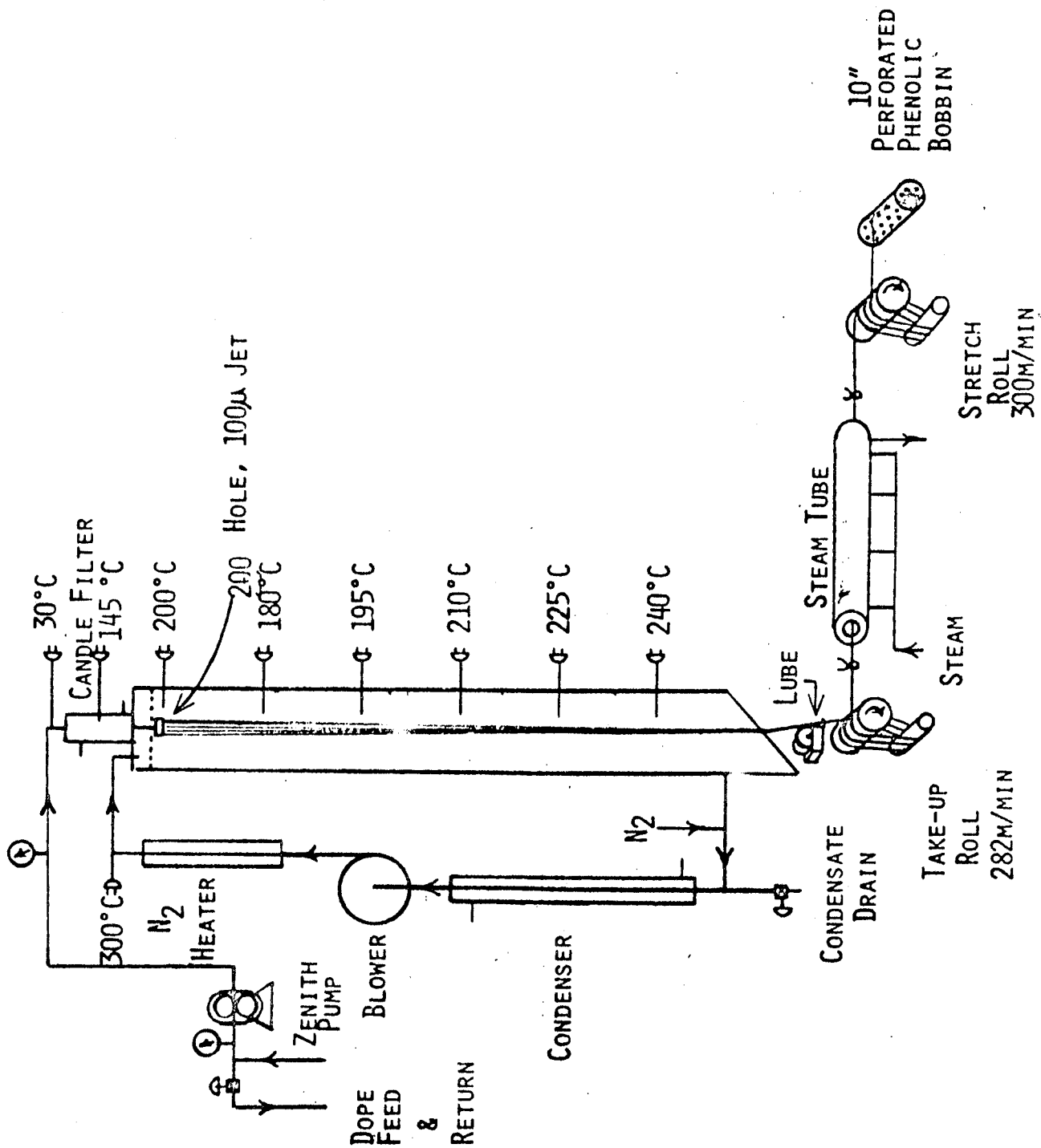

the result of increasing the temperature of the dope (spinning solution) in the candle filter.

Drawing trials, performed on the 450/110 and 600/110 yarns, are compared in Table VI with the typical production yarn. The optimization of the 4:1 draw of the 600/110 yarn has not yet been tried.

TABLE VI
EVALUATION OF HIGHER FILAMENT DENIERS

	<u>Denier/ Filament</u>	<u>Draw Ratio</u>	<u>Tenacity</u>	<u>Elongation</u>	<u>TE¹/₂</u>
Spun	300/110	---	1.7 g/d	75.7%	15.2
Drawn	165/110	2:1	4.5	22.2	20.7
Spun	450/110	---	1.7	88.0	16.4
Drawn	165/110	3:1	5.9	15.6	23.2
Spun	600/110	---	1.6	95.8	15.3
Drawn	220/110	3:1	5.2	16.5	21.0
Drawn	165/110	4:1	4.2	9.1	12.8

d. Jet Starting Techniques. Jet starting has often required many hours and even days before stable spinning was achieved. The demonstration of new techniques described below points to a potential savings in the overall operating time cycle or stream efficiency and materials usage or conversion efficiency.

During the preparation of multifilament yarns, a new technique for starting a spinning jet was found that results in a uniform extrusion and filament formation from all of the holes within a short time. This is accomplished by (a) raising the oil temperature of the candle filter from 110 to 150° C, (b) increasing the initial extrusion rate to at least twice the normal rate, (c) immersion of the jet face in "j-oil", and (d) "picking" of the jet face to remove blebs or dried dope.

Superior results were obtained during additional tests in rapid jet-starting methods. A filtered 50/50 mixture of j-oil and DMAc was introduced into the jet assembly prior to its installation on the column. Upon initiating the extrusion of dope from the jet, the fils tended to fall free from the jet with little or no blebbing. Further examination of this approach substantiated these findings. In addition, the same mixtures of j-oil and DMAc

when squirted on the face of the jet immediately removes any blebs of dope. Successful demonstration of the above techniques lead to sizeable reductions in start-up time in the spinning operations.

A spin trial, using high I. V. two-stage polymer (0.85 I. V.) at 23% solids concentration with 2% LiCl on the DMAc level, was unsuccessful with either a 200-hole or 250-hole jet. The dope which appeared to be very viscous was found to have a Brookfield viscosity of 265,000 centipoise as against the previous level of about 110,000 centipoise. This highly viscous dope was reduced in solids concentration by the addition of fresh solvent. Spinnings were then successfully performed with much greater ease and without a real change in the property levels as shown in the following table:

EFFECT OF DOPE VISCOSITY ON FILAMENT PROPERTIES

Dope Viscosity Centipoise	As-Spun		Washed & Dried		Drawn		
	g/d Ten	% Elong.	g/d Ten.	% Elong.	g/d Ten	% Elong	TE $\frac{1}{2}$
265,000	1.01	96.3	1.43	97.7	4.82	18.1	20.6
150,000	1.02	92.7	1.47	104.4	4.59	21.7	21.4

e. Multifilament Spinning. A 200-hole jet (125 micron) having one circle of holes was started without difficulty. This results in an 82% increase in throughput. The yarn possessed slightly lower tenacity levels, however, possibly as a result of a larger hole size. Additional 200-hole jets have been started, using an improved starting technique described below, including those with 100-micron holes. Improved spun fiber properties would be expected from the smaller 100-micron hole as compared to 125-micron hole jets below for 3.0 dpf fibers.

EFFECT OF JET HOLE SIZE

Holes		Filament Properties		
Number	Size μ	Elong, %	Ten, g/d	TE $\frac{1}{2}$
200	125	98.6	1.41	14.1
		74.6	1.59	13.8
200	100	85.3	1.54	14.3

An attempt to start a 300-hole jet was unsuccessful with blebbing being experienced over the three rings (80-100-120). A new approach will be needed for starting multiple ring jets. The largest number of holes possible in a single ring using 3" jets is 200.

A 5.5 lb (dry weight) bobbin of 540 denier/200 filament as-spun yarn was prepared at 300 m/min as one of the contract objectives. Large packages were prepared for use in the tow process demonstration since continuous processing was used.

f. Steam Stretching. Additional bobbins of various filament count yarns were spun with and without steam stretching. Since the spun yarn will undergo washing, drying, and drawing in a continuous manner, the elimination of steam stretching was considered feasible. This would reduce the process equipment required on a commercial scale.

These yarns were evaluated by obtaining filament properties at each stage during the processing operations.

TABLE VII
EFFECT OF STEAM STRETCH ON PROPERTIES

No. of Fils	Steam Stretch	Hole Size μ	<u>Washed & Dried</u>			<u>Drawn</u>		
			Ten. g/d	Elong. %	TE $\frac{1}{2}$	Ten. g/d	Elong. %	TE $\frac{1}{2}$
50	yes	100	1.43	97.7	14.2	4.8	18.2	20.6
	no		1.44	97.3	14.2	4.5	16.0	18.0
110	yes	100	1.37	81.5	12.4	4.1	20.8	18.7
	no		1.38	88.5	13.1	4.6	17.6	19.4
150	yes	125	1.66	77.0	14.6			
	no		1.54	83.6	14.2			
200	yes	100	1.54	85.3	14.3			
	no		1.49	95.8	14.7			

The above results demonstrate that steam stretching is not required to obtain properties and can be eliminated when continuous processing methods are used.

g. Accident Report. A fire of explosive violence flashed out of the head of one of the two spinning columns during a spinning run. One of the operating personnel received first and second degree burns of the face and abrasion of the cornea of the left eye. There was no significant damage to the Government-owned property as a result of the incident.

The column, a 20-foot, downdraft type, heated dry spinning column was in operation spinning a dope consisting of polybenzimidazole (PBI) polymer and dimethylacetamide (DMAc) solvent. The column extends from the first to the third floor. The spinning facility includes a newly designed solvent recovery system. A heated nitrogen atmosphere is circulated through the column during normal spinning operations.

Average system temperatures are as follows:

- (1) Spinning dope at jet - 150° C
- (2) Nitrogen entering column - 300° C
- (3) Upper column - 180° C
- (4) Lower column - 240° C

At approximately 1:02 P.M., a yarn break occurred in the column. The column head doors were opened to insert a catch pan and the column base door was opened to remove waste yarn. When the column was cleared, a technician went to the third floor to restart the process. It is reported by the technician that he found the spinning jet fouled and noticed a considerable concentration of solvent fumes in the column head. He called his partner on the intercom for assistance in changing the jet. At approximately 1:08 P.M., as the partner was entering the room, fire flashed out of the column head with explosive violence. The technician, who was standing in front of the column head, was thrown to the floor with facial burns. A pipefitter working in the next room, reported that there was no sustained fire when he entered the room within seconds of the incident.

Examination of the spinning facilities following the incident revealed the following factors:

- (1) The circulating blower switch was on but the unit was not functioning.
- (2) The temperature recorder indicated that the blower failed at 1:02 P.M. (time of the initial yarn break) and that the ignition occurred at 1:08 P.M.
- (3) The blower housing contained about 1-gallon of DMAc which probably caused the blower failure.

As a result of the blower failure and the opening of doors at the top and bottom of the column, air apparently entered the column. This caused an explosive mixture of DMAc vapors and oxygen from the air. Although the actual source of ignition is undetermined, metal friction sparking or static electric discharge are considered likely sources.

The spinning columns were inoperable for six weeks as a result of the accident discussed above. During this time, modifications to both spin

columns were made in order to make the systems "fail-safe". In addition to the changes which will prevent future accumulations of liquid DMAc in the gas condensing and circulating system, various automatic devices were installed that are activated when the flow through the column is interrupted. These sound a warning alarm and turn off the nitrogen heaters and dope zenith pumps. In addition, a dumping system to purge each column of its contents with a high flow of nitrogen is activated. A low level alarm has also been installed to signal any loss in pressure in the house nitrogen system since a constant flow is required for constant make-up to the operating columns.

Since completion of the modifications and installation of the safety devices both columns were tested out under conditions that very closely approximated those in use at the time of the accident. The tests indicated that the columns were functioning in a completely satisfactory manner. The safety devices were adjusted and calibrated to permit the normal and small fluctuations experienced in flows and pressures, but all alarms and cut-offs were found to function whenever the allowable limits are exceeded.

h. DMAc Condensate. The spinning solvent (DMAc) is purchased in drum quantities at \$0.53 per pound and represents a sizeable cost factor in a production operation. Since recovery is included in our plant design, analysis was performed on DMAc recovered from the spinning system. The following GC results indicate water and acetic acid to be the major contaminants. A sample of the recovered solvent was heated to its normal boiling point with the simple distillation of 10% of the charge. The distillate and residual solvent were examined; however, the results below demonstrate that a simple distillation is not sufficient.

TABLE VIII

DMAc ANALYSIS

<u>Constituents</u>	<u>Fresh</u>	<u>Recovered</u>	<u>Residual Solvent(90%)</u>	<u>Distillate(10%)</u>
DMAc, %	99.87	98.20	99.34	81.58
Water, %	0.08	1.06	0.26	18.26
Acetic Acid, %		0.47	0.29	
Dimethyl Amine, %		0.14	0.10	0.02
Unknown, %	0.05	0.13	0.01	0.14

New approaches are being considered for the removal of the DMAc vapor from the gas stream exiting at the base of the spinning columns. It is possible that some of the contaminants in the DMAc mentioned above were formed when DMAc reached the nitrogen heater elements. The complete condensation of the DMAc vapors might reduce the levels of acetic acid and dimethyl amine.

Additional discussion on spinning development is included in a later section entitled DEMONSTRATION.

5. WASHING

a. Historical Background. Batch washing of as-spun yarn to remove residual DMAc and LiCl on the perforated phenolic bobbins has previously been performed in a 26-position pressure wash tank at 50°C for 60 hours. The objective of this phase of the program is to determine and demonstrate a continuous washing process, preferably in-line with drying and drawing.

b. DMAc Analysis. The analytical determination of residual dimethyl acetamide (DMAc) in PBI yarn has, in the past, been performed by dissolution of the sample in concentrated sulfuric acid followed by subsequent neutralization with sodium hydroxide and then gas chromatographic (GC) measurement of the free DMAc. Unfortunately, the injection of the sulfate salts into the hot injection port on the GC column gave a large peak on the chromatogram with the DMAc component appearing as a smaller peak on the tail of the first one. This peak is difficult to resolve when the DMAc level is below 1.0%. A new technique was therefore required and is given in Appendix II.

An extraction procedure has been developed for the accurate determination of DMAc down to levels as low as 0.01%. The sample is soxhlet extracted with distilled water for eight hours followed by dilution to a known volume and then analyzed by GC. The salt peak, previously noted, was not present and thereby resulting in greater accuracy. These for complete extraction of the fiber were made on the inlet probe of the Bendix Time-of-Flight Mass Spectrometer. Fibers analyzing 13.7, 4.1 and 0.3% DMAc all showed extracted fiber DMAc levels of less than 0.01% indicating complete extraction.

c. Initial Washing Trials. The initial trials on continuous washing of 3.0 dpf as-spun yarn were performed with encouraging results. The objective of this work was to determine the parameters and conditions required to remove the spinning solvent (DMAc) with water in a continuous manner.

A 5' x 3" x 4" stainless steel trough was used as a wash tank in the first study in which a 990 filament (2700 denier) yarn was passed through a 1.5 meter bath using a counter-current flow rate of 0.5 gal/min at various temperatures and yarn speeds or residence times. Independent idler rolls were employed to obtain multiple passes (all under water) and baffles to agitate the water flow.

Table IX shows three series of experiments performed in this system. The first consisted of passing the 990 filament bundle through the bath using a flow of hot water at 55°C. The second series, run at 0.5 to 20 m/min,

TABLE IX

IMMERSION WASHING TRIALS

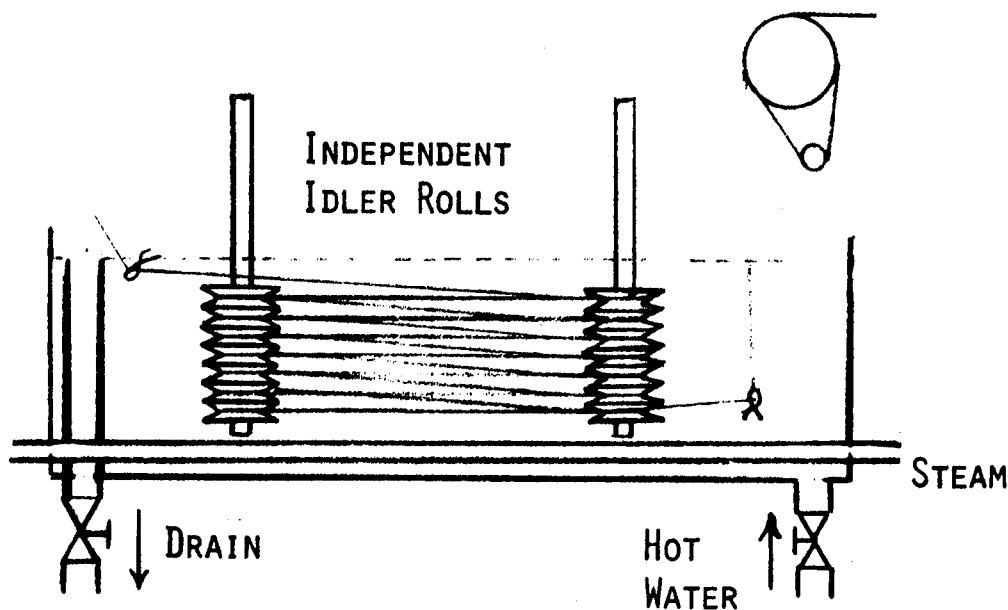

<u>RESIDENCE TIME</u>	<u>BATH TEMP.</u>	<u>RESIDUAL DMAc</u>
43 MIN.	55°C	0.01%
21.5		0.31
10.8		0.26
3.0		4.1
1.5		4.9
0.75		5.5
0.38		6.9
14.2	90	0.16
7.1		0.60
4.3		1.1
2.2		1.6
1.1		3.2
0.5		3.4
7.1	90, WITH	0.14
4.3	SURFACE WIPE	0.27

TABLE X

PARTIAL IMMERSION WASHING TRIALS

2700/990 YARN

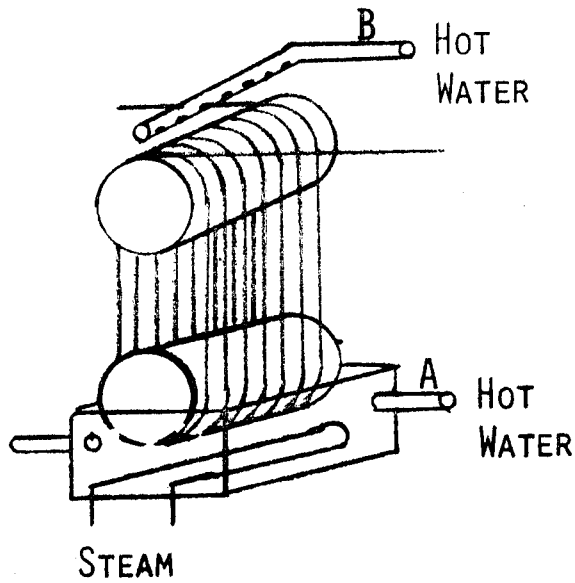

	<u>RESIDENCE TIME</u>	<u>BATH TEMP.</u>	<u>RESIDUAL DMAc</u>
A	22.2 MIN.	75°C	4.5%
	9.4	72	2.6
	4.7	70	4.6
	2.4	68	5.1
B	22.2	60	0.6
	4.7	60	2.4

employed the use of heating tubes in the base of the trough through which low pressure steam was passed to heat the water to 90°C. Note the significant decrease in residual DMAc at the higher temperature. However, it was noted that the yarn was completely covered with bubbles as it passed through the water. Considering that these would act as a barrier between the water and the yarn and thus decrease the efficiency of the extraction, two sets of rods were inserted so as to wipe the yarn free of bubbles as the yarn passed by. A four-fold decrease in the residual DMAc resulted from this treatment. A more efficient means of eliminating this surface phenomena will be evaluated. The use of rolls and pins to remove these bubbles and to spread the bundle of filaments into a band will be tried. In this way, the exposed surface areas will be increased and a further reduction in the required residence time is to be expected.

The effect of bath temperature and surface wipe on DMAc removal is clearly shown by the graph in Figure 7.

A second system was evaluated as providing a means by which yarn may be continuously washed. It consists of two parallel rolls with the lower one partially immersed in a bath. The first series of runs, as shown in Table X was performed using hot water feed to the bath which was in turn heated with a steam line. The results were not very good in spite of the smooth band of yarn produced and ease of operation. Considering the small percentage of yarn immersed in water, the hot water feed was directed to a perforated tube located over the top roll. Two runs at 2 and 10 m/min with 23.5 and 4.7 minutes residence time, respectively, showed an improvement but not as good as the complete immersion system.

d. Continuous Immersion Washing. A larger wash trough 6' x 6" x 8" was fabricated to accommodate grooved rolls and permit longer residence times. Samples were produced at 90°C using 2700/990 yarn in a 50 m zone as follows in Table XI.

TABLE XI
EFFECT OF RESIDENCE TIME ON DMAc LEVEL

<u>Residence Time (min)</u>	<u>Yarn Speed (m/min)</u>	<u>Residual Solvent Level (%)</u>		
		<u>Trial 1</u>	<u>Trial 2</u>	<u>Trial 3</u>
16.5 min.	3	0.10	0.18	0.08
5.5 min.	9	0.10	0.22	0.11
3.3 min.	15	0.17	0.28	0.27
2.3 min.	21			0.36
1.8 min.	27			0.45

FIGURE 7

EFFECT OF TEMPERATURE ON WASHING

2700/990 As-SPUN PBI YARN

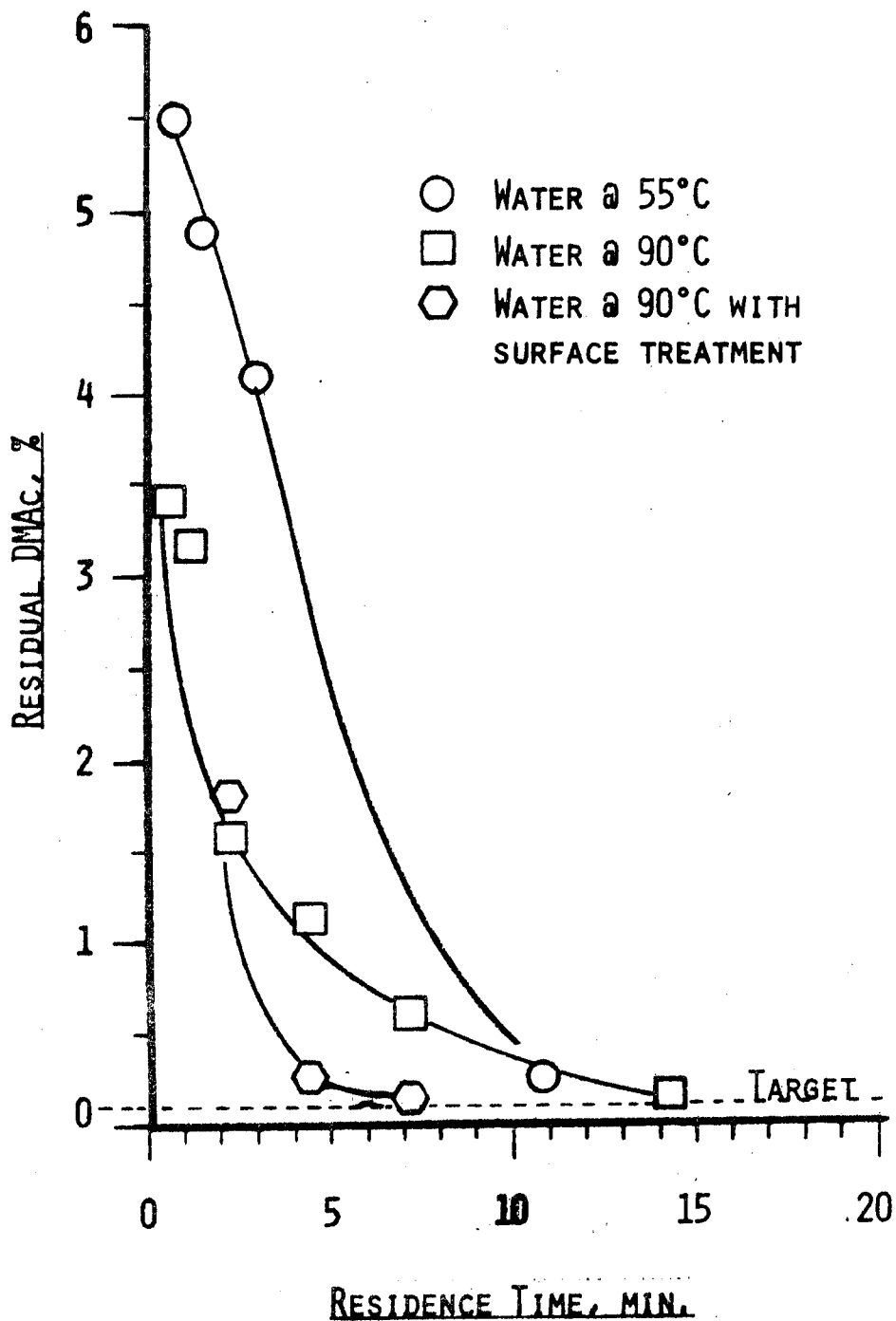

A lower DMAc level was obtained for a given yarn speed in the above study than was observed in previous studies. This is attributed to the additional movement of the filaments at higher speeds which increases the extracting process.

Samples of 8100/2970 yarn were prepared on the same unit with slightly higher DMAc levels being obtained for the three-fold increase in denier as shown in Table XII below:

TABLE XII

WASHING OF 8100/2970 YARN

<u>Residence Time (min)</u>	<u>Yarn Speed(m/</u>	<u>Residual DMAc (%)</u>
16.5	3	0.14
5.5	9	0.25
3.3	15	0.31

Tension build-up on the grooved rolls was found to be sufficient to result in a significant level of broken fils. These rolls were therefore replaced with rolls having ball bearings and a flat surface. The grooves tended to give a bundle of yarns whereas the flat rolls gave flat bands which could provide better contact with the water. Since the grooves had provided a simple means of spacing the bundles, stainless steel textile combs were provided in front of each roll to act as guides as well as wiping blades to remove the surface bubbles. A reduction in the level of broken fils was observed.

Further washing trials in the horizontal trough were performed following the application of a drive assembly to the vertical rolls as shown in Figure 8 and the installation of a circulating pump and heat exchanger.

TABLE XIII

WASHING OF VARIOUS TOW DENIERS

<u>Residence Time(min.)</u>	<u>Yarn Speed (m/min)</u>	<u>Residual Solvent Level (%)</u>		
		<u>990 fil</u>	<u>2970 fil</u>	<u>4950 fil</u>
16.5	3	0.05	0.06	0.07
5.5	9	0.02	0.10	0.17
3.3	15	0.04	0.14	0.35
2.0	25	0.08	0.23	0.31

FIGURE 8

CONTINUOUS TOTAL IMMERSION WASHING EQUIPMENT

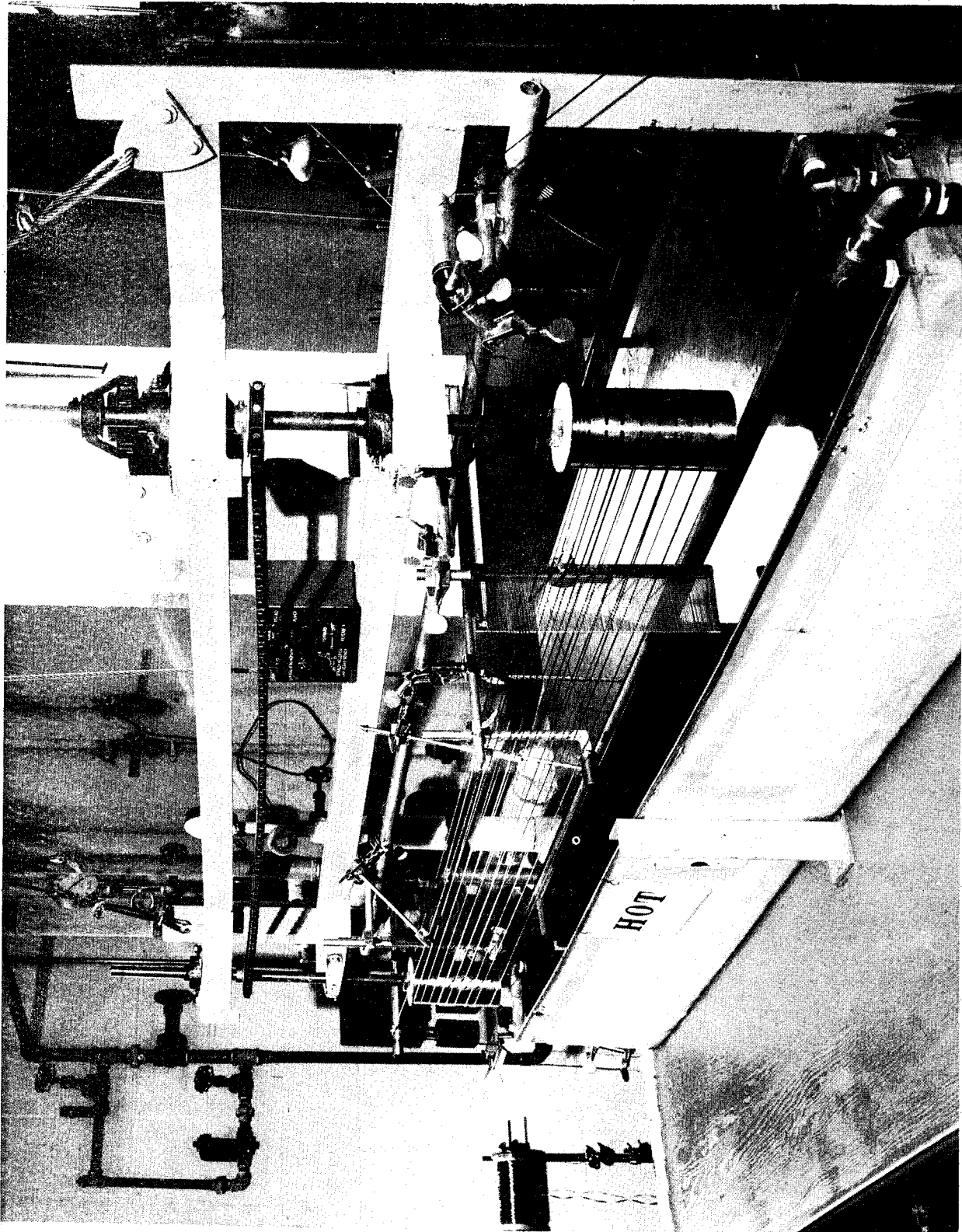

The higher residual solvent levels in the two higher count yarns of Table XIII is attributed to the inability of the yarn to flare out into a mono-layer of filaments on the non-skewed assembly, thus decreasing the contact with the water. The washing data given in Table XIV below from another system with ca 1000, 3000, and 6000 filaments depicts how the same levels can be obtained when the fils are able to spread out evenly.

e. Continuous Spray Washing. An alternate washing system (Fig 9) for the one described above consists of two parallel rolls with the lower one partially immersed in a bath. A hot water feed is directed to a perforated tube located over the top roll and a spray of hot water permitted to cascade down over the yarn. In order to further compare the effectiveness of this system to the total immersion system, three different tow levels were washed at 73-75°C with the results as indicated in Table XIV below.

TABLE XIV
WASHING OF VARIOUS TOW DENIERS

<u>Residence Time(min.)</u>	<u>Yarn Speed (m/min)</u>	<u>Residual Solvent Level (%)</u>		
		<u>2700/900</u>	<u>8100/2970</u>	<u>16200/5940</u>
28.5	2	0.27	0.36	0.27
4.7	10	1.60	1.60	2.19

The above results clearly establish that the horizontal trough, with complete immersion, results in residual DMAc levels lower by a factor of five or more compared with yarn washed vertically on two parallel rolls.

f. Comparison of Washing Systems. A final comparison between total immersion and partially immersed rolls with spray was made prior to the decision for the final design. In this series of tests, the parameters were identical for each of the two systems as follows:

- a. Spin Bobbin, 2700/990
- b. Yarn speed
- c. Residence time
- d. Water rate, 0.75 gal/min
- e. Water temperature
- f. Day of analysis

The percent residual DMAc results tabulated below conclusively demonstrate the following:

- a. Target values at one m/min were obtained with immersion but not with spray.
- b. Target values at five m/min were obtained with immersion by increasing the water temperature.

FIGURE 9

CONTINUOUS WATER SPRAY WASHING EQUIPMENT

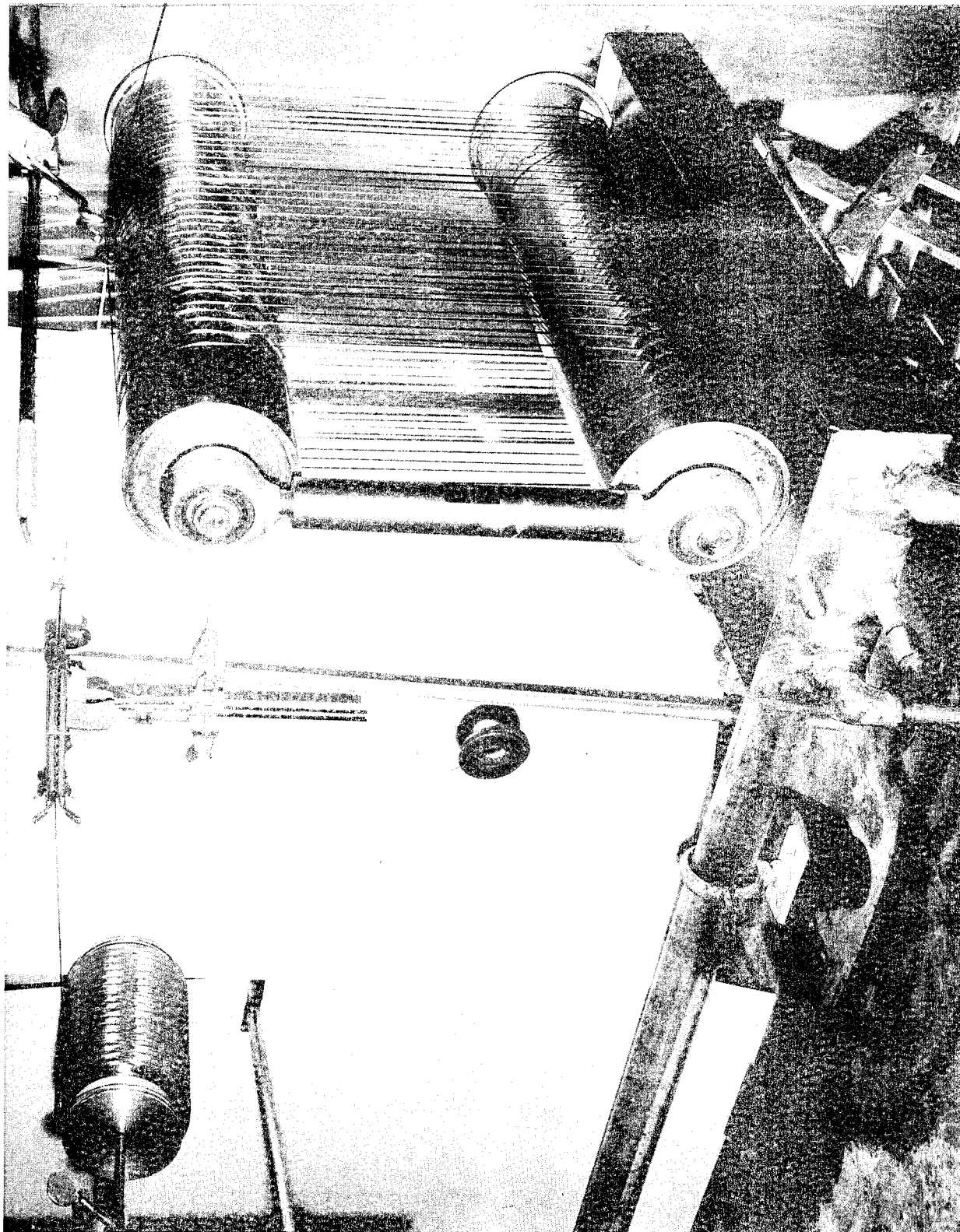

- c. The use of a nip roll on the spray system was only marginally beneficial at the slower speed.

TABLE XV
COMPARISON OF WASHING SYSTEMS

DMAc Residual Levels*

Yarn Speed/ Residence Time	Spray on Rolls		Rolls Immersed	
	No Nip @ 62°C	Nip @ 62°C	62°C	95°C
1 m/min. 25 min.	0.37%	0.15%	0.01%	0.02%
5 m/min. 5 min.	0.83%	0.80%	0.19%	0.01%

* analysis of residual DMAc by gas chromatograph.

The above immersion tests employed a 25 meter zone. Table XVI again shows the results at 95°C with two additional results. The third result represents the findings when the same zone is maintained but the speed is increased to give a shorter residence time (2 min). The last result was obtained with a 78.6 meter zone at 37.8 m/min to give the same residence time at the fastest speed possible on this unit. This speed begins to approximate production speeds.

TABLE XVI
EFFECT OF RESIDENCE TIME ON DMAc-REMOVAL

<u>Yarn Speed</u> <u>(m/min.)</u>	<u>Zone, (m)</u>	<u>Residence Time</u> <u>(min.)</u>	<u>Residual</u> <u>DMAc(%)</u>
1.0	25	25	0.02
5.0	25	5	0.01
12.5	25	2	0.03
37.8	78.6	2	0.08

g. Instron Tests. Since broken fils have occurred during some of the washing trials, and the 5940 fil yarn could not be washed in the horizontal trough because of the apparent shrinkage forces which caused the ends of the rolls to bend inward, these forces were examined on an Instron tester. Various shrinkage forces were determined by treating 2700/990 as-spun yarn as follows:

A sample of as-spun yarn was attached to the Instron Tester which was then washed with 90°C water in place. This resulted in a load of 146 grams or 0.5 grams/denier. On removal of the water, the sample underwent an additional loading of 190 grams at room temperature suggesting that other forces occur during drying.

These dry loads were further evaluated by washing the yarn freely at 95°C, affixing it to the Instron Tester and then drying in place with a muffle furnace. A 400 gram tension resulted on drying at 300°C followed by an additional instantaneous 400 grams of tension after removal of the furnace, presumably occurring as the sample cooled.

Since a thermal process for the removal of DMAc in the spun yarn might be feasible at some time, as-spun yarn was also treated at 300°C with a resulting tension of 350 grams followed by 250 grams on removal of the furnace.

The above forces were considered in the design of the continuous washing processes. It is also interesting to note that the yarn freely shrinks about 13% when it is washed, dried, or thermally treated as is.

h. Equipment Design. Based on the above work, the total immersion approach to continuous washing was chosen for the tow process. The design of the washing assembly (all in stainless steel) consisted of two 6-inch diameter x 40-in rolls spaced 79 inches apart in each of two water tanks (results in staging), heat exchangers and circulating pumps for each tank, drives, exit nip roll, and a yarn dancer to regulate yarn speed equal to that of yarn drying assembly. The washing assembly is shown in Figure 10 and also with respect to other components in the tow process in Figure 11.

6. DRYING

a. Background. The washed yarn must be thoroughly dried prior to its being drawn at high temperatures. Failure to remove all of the water completely results in the disruption of the yarn as the water is rapidly volatilized. Such rapid volatilization forms hollow filaments with consequent loss in properties as well as resulting in generally unstable processing with frequent breaks or broken fils. Batch drying of two-pound bobbins at 150°C in air

FIGURE 10

PBI TOW WASHING SYSTEM

TOP VIEW

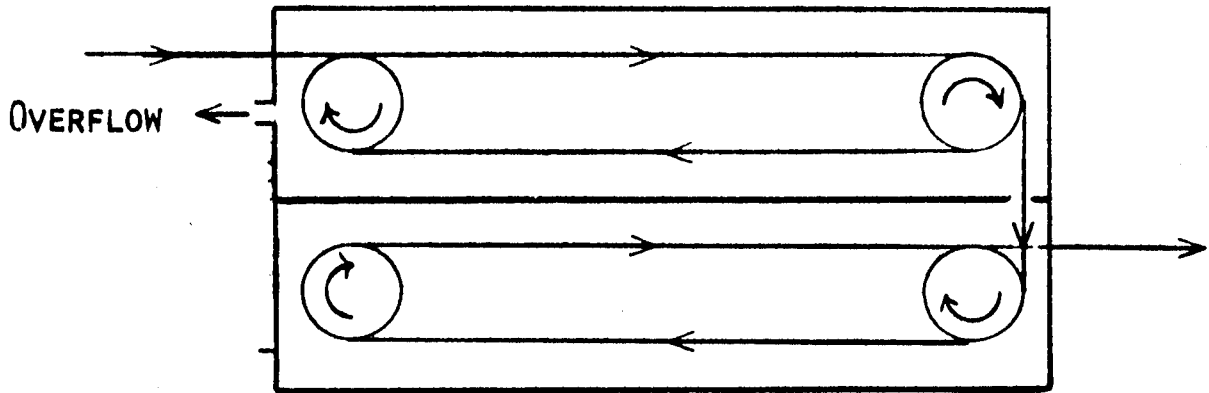

FRONT VIEW

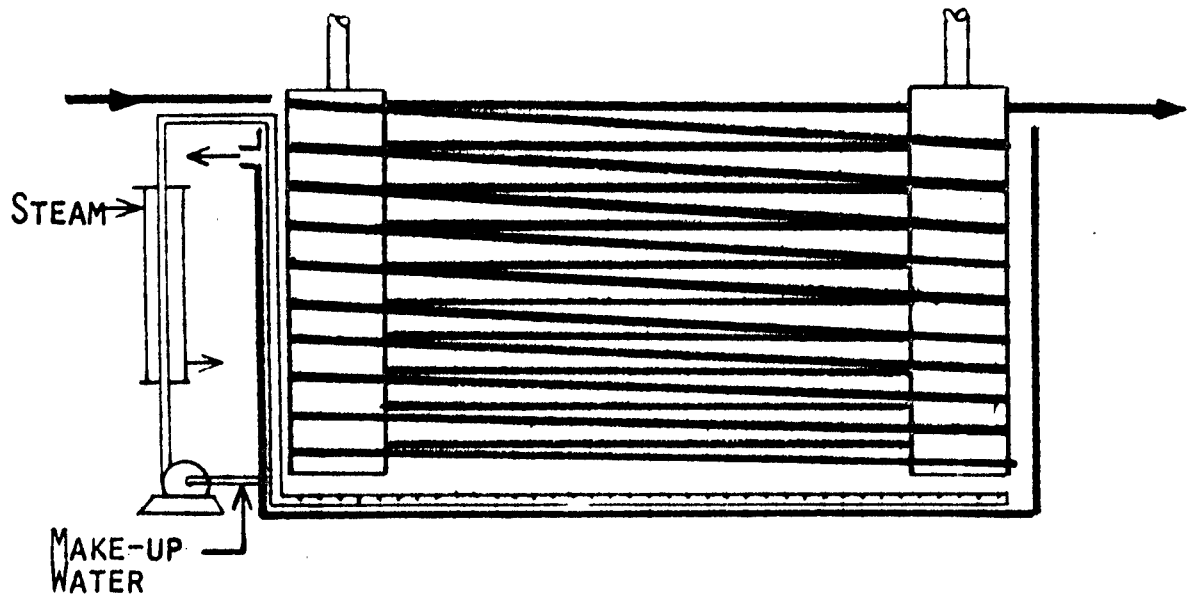

circulating ovens has taken upwards of eight days to dry. Continuous processing would have the advantage of reduced materials handling and process equipment.

In the previous contracts, drawing of oven dried yarn was carried out by making the multiple passes over various types of grooved rolls on bearings through muffle furnaces or the radiant heat (RHE) oven. Since then, hot shoe drawing has been developed and employed in the production of well over 2000 lbs of staple fiber with improved product uniformity.

In other earlier work, polymer fractions obtained from molecular weight fractionation were evaluated by spinning and drawing. Spinnings were carried out using the previous standard conditions and drawing conditions of 520°C, feed at 50 m/min, 2.2:1 draw ratio, and 9 passes through the muffle furnace to give a 4.0 dpf yarn. The I. V. values of the fractions together with the physical properties of the spun and drawn yarns are given in Table XVII.

TABLE XVII
SPINNING AND DRAWING EVALUATION
OF VARIOUS I.V. LEVEL POLYMERS

I. V.		12 dpf			4dpf		
Polymer	Yarn	Spun Properties		TE $\frac{1}{2}$	Drawn Properties		TE $\frac{1}{2}$
		Ten., g/d	Elong., %		Ten., g/d	Elong., %	
0.7	0.7	1.7	112	18	4.9	22	23
0.95	0.90	1.9	116	20	5.1	26	26
1.1	0.85	1.9	123	21	5.5	22	26
1.3	1.1	2.0	138	23	5.8	25	29

Table XVII shows improvement in yarn properties with increase of polymer I. V., thus this effect has been verified on a large scale. The table also indicates lower I. V. values for the yarn as compared to the polymer. This might be due to the fact that some high I. V. portion of the two-stage polymer fraction is insoluble under the solutioning conditions employed and therefore filtered out in the dope preparation equipment.

b. Thermal Treatment of As-Spun Yarn. Isothermal TGA's of as-spun yarn were obtained at 150, 200, 250, and 300°C as shown in Figure 12. These curves show appreciable weight loss with time.

Since washing yarn is an expensive step which must also be followed by drying prior to drawing, the removal of residual DMAc and water from the as-spun yarn by the direct application of heat in a continuous manner was

ISOTHERMAL TGA

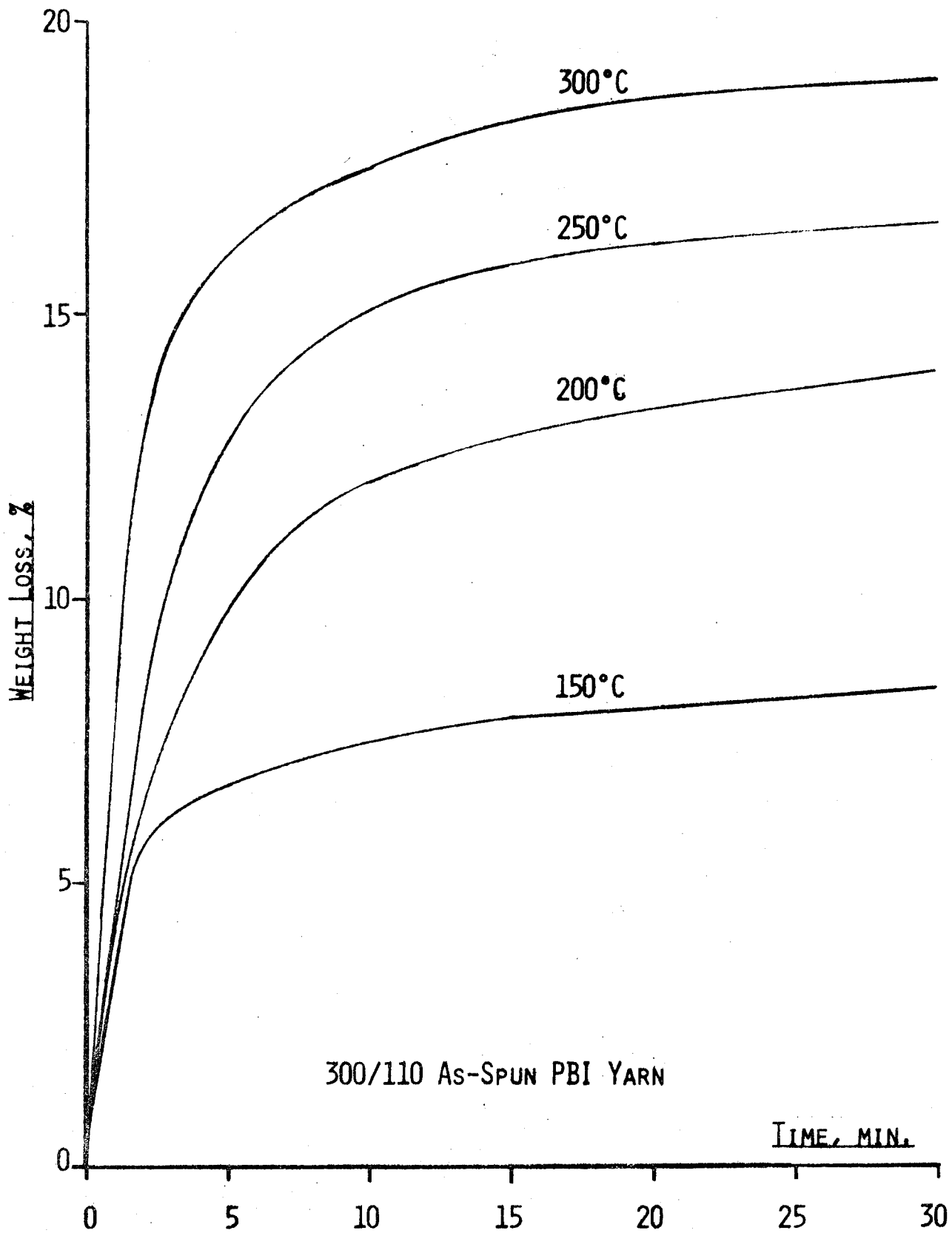

300/110 As-SPUN PBI YARN

TIME, MIN.

attempted with a significant degree of success. Yarn was passed over two hot shoes and through four muffle furnaces with identical feed and take-up speeds. The physical properties of these yarns are compared in Table XVIII with washed and dried yarn. The residual DMAc level was still too high to draw.

The second series of experiments shown in Table XVIII depicts the effect of temperature on the removal of DMAc. The loss of elongation could be either oxidative degradation or the effect of the residual lithium chloride salt. This approach could have merit if the one-stage polymer is found to be both more soluble in DMAc and more stable so that LiCl is no longer required as a dope stabilization additive.

An extension of the above work was made to reduce the equipment requirements associated with a continuous staple tow process by drawing unwashed yarn directly on the hot shoes. While the initial trials gave very poor properties at take-up speed of 10 m/min, subsequent trials at 1 and 2 m/min gave improved properties ($T = 2.15$, $E = 21.34$, $TE\frac{1}{2} = 10$) when the shoe temperatures were staged and the contact on the second shoe was reduced. Some additional work in this area is warranted.

c. Initial Drying Trials. Washed 300/110 yarn was removed from a water bath and strung up to pass over two hot shoes (20-inch zone) and through four muffle furnaces (4 foot zone). Speeds of one to twenty meters per minute were employed up to temperatures of 450° C in preparing samples for analysis. All of the samples exhibited a 5.5 to 6.0% residual volatile level which was identified as water by Karl Fisher analysis. The samples picked up moisture during their preparation, handling, and analysis, a factor in keeping with the high moisture regain of PBI fiber.

Isothermal TGA of washed yarn showed loss of moisture at 150 and 200° C within three and two minutes, respectively. The drying equipment was re-assembled to permit multiple passes through the muffle furnaces (32 foot zone) and then directly on to the hot shoes on which the yarn was drawn at a 2:1 ratio. A series of trials were run with exceptional operational stability and excellent properties as shown in Table XIX. The conditions employed were not optimized, but take-up speeds as high as 100 m/min were possible. Continuous drying would not be expected to be difficult.

d. Tandem Drying and Drawing. In a similar way, batch washed and dried 2700/990 yarn has been successfully tandem dried through two muffle furnaces (40 foot zone) and three hot shoes (10 inches per shoe) and drawn to give the properties tabulated in Table XX below.

TABLE XVIII

EFFECT OF HEATING ON YARN PROPERTIES

300/110 YARN

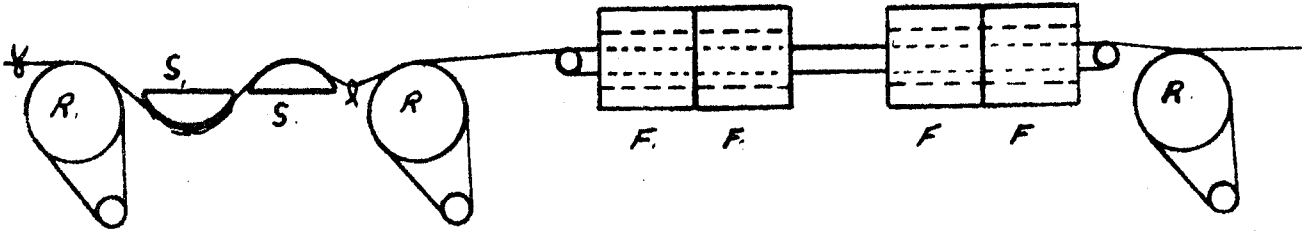

ROLLS (R)	SHOES (S)	FURNACES (F)	ZONE		PROPERTIES		
			S	F	TEN.	ELONG.	DMAC
1 M/MIN	275 °C	250 °C	20 IN	20 FT	1.59	61.2	
"	275	300	"	"	2.04	66.6	3.0
"	275	250	"	36 FT	1.45	79.0	
"	275	225	"	"	1.44	70.8	7.1

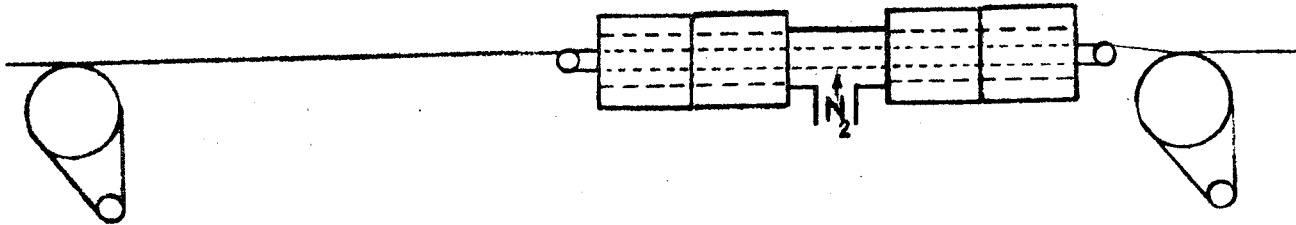

1 M/MIN		275 °C	36 FT	1.66	55.9	4.3
"		300	"	1.89	71.8	1.6
"		325	"	1.77	56.0	1.15
"		350	"	1.69	43.7	0.39

WASHED & DRIED

	1.74	75.7	<0.05
	G/D	%	%

TABLE XIX

IN-LINE DRYING-DRAWING TRIALS

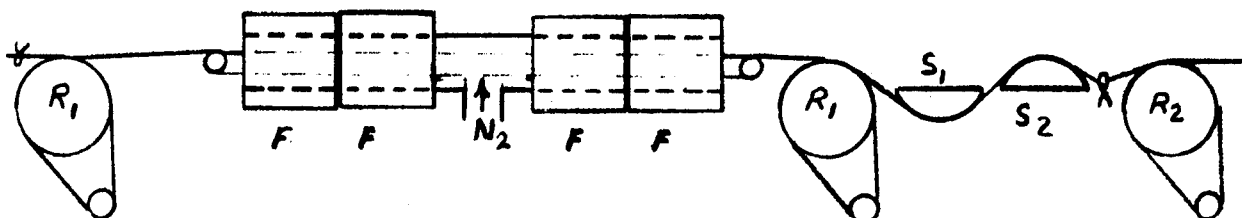

ROLLS, M/MIN		FURNACE, °C	SHOES, °C		TEN., G/D	ELONG., %
R ₁	R ₂		S ₁	S ₂		
20	40	275	340	430	4.03	25.1
30	60	275	340	430	4.22	29.3
30	60	275	360	440	3.78	25.3
40	80	275	360	440	3.63	26.3
40	80	325	360	440	4.45	26.9
40	80	400	360	440	3.97	29.7
50	100	400	360	440	4.54	28.3
50	100	400	380	450	3.76	28.7
50	100	350	380	450	3.73	28.4

FEED: 300/110
 DRAW RATIO: 2:1
 FINAL DPF : 1.5

TABLE XX

DRY-DRAW OF 990 FIL TOW

<u>Rolls m/min.</u>		<u>Furnace</u> °C	<u>Shoes °C</u>			<u>Tenacity</u> g/d	<u>Elong.</u> %
<u>R₁</u>	<u>R₂</u>		<u>S₁</u>	<u>S₂</u>	<u>S₃</u>		
20	40*	400*	385	440	-	3.78	13.2
20	40	400	300	400	450	4.87	17.2
30	60**	275**	340	430	-	4.75	22.9
30	60	275	360	440	-	4.80	21.5
30	60	275	375	445	-	4.74	28.8
30	60	275	320	456	-	3.74	28.0

* Yarn was soaking wet

** Yarn was previously batch dried

The above data clearly indicated that 990 fil yarn can be drawn. However, the drying zone had to be enlarged to handle the greater demand of higher fil counts at increased operating speeds. An additional furnace was then added to permit drying at less stringent conditions in a 60-foot zone.

Continuously washed yarn (2700/990) having a residual DMAc level of 0.13% was processed as shown below to give acceptable properties.

TABLE XXI

EVALUATION OF CONTINUOUSLY WASHED YARN

<u>Rolls m/min.</u>		<u>Furnaces</u> °C	<u>Shoes, °C</u>		<u>Tenacity</u> g/d	<u>Elong.</u> %
<u>R₁</u>	<u>R₂</u>		<u>S₁</u>	<u>S₂</u>		
20	40	350	375	440	4.16	22.4
30	60	350	375	440	4.31	21.6

Since higher processing speeds are desired, batch washed yarn was evaluated having a residual solvent level of 0.03% at take-up speeds of 80 and 100 m/min. The following data (Table XXII) on 990 fil yarn suggests that the furnace and/or shoe temperatures were too high. The use of a third shoe was aimed at evaluating the need for pre-heating when high yarn deniers are processed. This is apparently deleterious to the yarn properties.

TABLE XXII

EFFECT OF THIRD HOT SHOE

Rolls m/min.		Furnaces °C	Shoes, °C			Tenacity g/d	Elong. %
R ₁	R ₂		S ₁	S ₂	S ₃		
40	80	400	300	440	450	2.09	7.6
50	100	400	300	440	450	3.07	10.3
50	100	400	300	445	455	3.43	11.0
50	100	400	300	450	460	3.27	21.9

Additional work at high speeds was performed with continuously washed yarn having a residual solvent level of 0.25% prepared by plying 5 bobbins of the 200 fil yarn. This yarn was not steam stretched during its production. The data below in Table XXIII shows that production speeds can be utilized with continuously washed yarn.

TABLE XXIII

EVALUATION OF 1000 FIL CONTINUOUSLY WASHED YARN

Rolls m/min.		Furnaces °C	Shoes, °C		Tenacity g/d	Elong. %
R ₁	R ₂		S ₁	S ₂		
40	80	350	375	440	3.72	29.8
40	80	350	400	440	3.60	26.4
40	80	350	415	440	4.18	19.5
50	100	350	375	440	3.99	21.2
50	100	350	400	440	4.20	23.7
50	100	350	415	440	4.61	20.0
50	100	300	375	440	4.15	19.2

Additional work including the processing 1000, 2000, 3000, 4000, and 5000 filaments is covered in the section entitled DEMONSTRATION.

c. Equipment Design. The design of the drying assembly for the tow process included the radiant heat (RHE) oven which was modified to accept two 2-inch diameter x 11" rolls spaced 99 inches apart. It was further modified with covers for the rolls to keep the moving yarn hot, drives, and a dancer assembly for maintaining the yarn speed equal to that of the feed roll on the drawing assembly. Anti-static devices were also provided. This system is shown in Figure 11.

The drawing assembly design consisted of two sets of 6-inch diameter x 15-inch rolls with 3-inch diameter skewed rolls which are driven by Servo-Tek motors. Direct digital readout of yarn speed was provided to permit rapid speed control since more than one pound of yarn was processed every 10 to 15 minutes. Hot shoes, temperature controllers,

and a lube system were also provided. One of the present yarn packagers was modified to accept and take-up the 7500 denier yarn off the draw roll. The position of this unit in the tow process is also shown in Figure 11 (page 38).

9. SINGLE-STAGE POLYMER EVALUATION

a. Summary. Low properties were obtained on spinning and drawing yarns from both single-stage and two-stage polymers with the only noticeable difference being a darker yarn from the single-stage polymer. Only after the dope system was completely cleaned and control was exercised against moisture in the production of more dope from the two-stage polymer could yarn be spun and drawn to give not only target properties but a lighter color. Because of the questionable reliability of the single-stage polymer with respect to filterability, properties and color, two-stage polymer was employed in the balance of the tow demonstration.

b. Dope Preparation. Dope batches B-33 through -39 were prepared from single-stage polymer and exhibited lower viscosities than the two-stage polymers in the subsequent batches as shown in Table XXIV. Although the filter was plugged with an insoluble portion from the single-stage polymer, the dope from the spin manifold after the second filtration stage was noticeably free from gels or dirt and possessed viscosities slightly above the original solution.

Samples of dope from the manifold were examined by GC and MS. Water was found at a level of 0.5% and trace (<0.05%) amounts of phenol and acetic acid. The water content is believed to be higher than that previously experienced and may have contributed to the low properties.

The solvent, lithium chloride (LiCl) and polymer were found to contain about 0.03, 1.0, and 1.0 to 2.0 per cent water, respectively, which could account for the moisture found in the dope. The presence of water during the solutioning and storage of the dope could result in hydrolysis of the DMAc and formation of dimethylamine and acetic acid. Batches B-43 and -44 were therefore prepared with freshly dried LiCl and polymer that was kept covered from the atmosphere. The very light colored spun yarn with higher physical properties suggests that the varying levels of yarn color and properties observed in the past may be a function of the water level in the dope system.

Because of the difficulties encountered during the spinning trials with the single-stage polymer, as described later in that section, various batches were prepared and separately evaluated by segregating the dope lots.

TABLE XXIV

PBI DOPE BATCHES

<u>Dope Batch</u>	<u>Polymer</u>		<u>Dope Viscosities</u> ⁽¹⁾	
	<u>Batch</u> ⁽⁴⁾	<u>I. V.</u>	<u>Mixer</u> ⁽²⁾	<u>Manifold</u> ⁽³⁾
B-33	P-600	0.69	80M	280M
transferred to dope bombs after spinning trials				
B-34	P-902	0.73	80M	233M
B-35	"	"	120M	
transferred to storage drum after spinning trials				
B-36	P-907	0.78	88M	160M
B-37	P-908	0.89	125M	
B-38	P-908, 907	0.89, 0.78	110M	
B-39	P-909, 907	0.79, 0.78	90M	
transferred to storage drum after spinning trials				
B-40	P-(829- 830)A	0.86	200M	265M
B-41	"	"	245M	
transferred to storage drum after spinning trials system thoroughly cleaned out with solvents				
B-43	P-(831- 832)A	0.87	210M	235M
B-44	"	"	280M	

- (1) Brookfield viscosity in centipoise at 30°C.
- (2) Sample taken during transfer from mixer to filtration stage.
- (3) Sample taken from manifold at the top of the spinning columns.
- (4) P-900 series = single-stage process
P-800 series = two-stage process

It had been predicted from small scale studies that the single-stage polymer would be extremely soluble resulting in a significant savings in filtration time and materials. Experience with current polymers has been quite to the contrary. They have shown a sizeable portion of material that is insoluble in the spinning solvent that is caught by the first stage filter which rapidly plugs it, resulting in a filter life of about 100 pounds of processed polymer. This represents one-fourth of the level experienced with two-stage polymer. It is interesting to note that the opposite is true when the polymer is solutioned in sulfuric acid and filtered to determine the polymer IV.

c. Spinning Evaluation. Spinning trials with the first three dope batches described in the previous section all gave yarns possessing properties below those previously obtained with two-stage polymers. These trials are tabulated in Table XXV.

Various parameters were examined including polymer viscosity, dope viscosity, spinning speed, candle filter temperature, and spun denier. No significant responses with tenacity were noted, but elongation was increased with higher fil counts and higher filament deniers. It should be noted that 50, 110, and 200 filament yarns have been spun from two-stage polymer having tenacities of 1.43, 1.38, and 1.41 g/d, respectively, with target properties being obtained in each case on drawing.

Samples of spun yarn were compared to retained samples from previous spinnings for physical differences in an attempt to explain the reduced property levels. Longitudinal sections and cross sections of the yarns were examined microscopically for voids or fractures with none being observed. Samples were also examined by small angle x-ray diffraction for voids with no appreciable response. Wide-angle x-ray diffraction analysis indicated no differences between the crystalline or orientation levels of the spun yarns. The residual solvent level of the spun yarns was also found to be at a normal level. The most obvious difference between the yarns from the two polymers is that the single-stage polymer yields a much darker yarn.

A check-out of the dope preparation and spinning systems was made by processing a batch of two-stage polymer. The most significant improvement as shown in Table XXV was with the spinning of dope batches B-43 and -44, which were drier and were much lighter in color. Target properties were achieved on drawing as described below. Additional spinnings with 200-hole jets and dope having a low water content demonstrated properties equivalent to that obtained in a

TABLE XXV
PBI SPINNING TRIALS

Dope Batch	Spinning Date-Bobbin	Jet Holes	Takeup		Candle °C	Physical Properties ⁽¹⁾				
			Speed m/m	Column °C top/bottom		DPF	Ten., g/d	Elong. %		
B-33	3-5-71-8	200	300	175/239	145	2.5	1.29	64.2		
B-34 & 35	3-22-71	200	300	165/240	145	--	--	--		
	Not stable ⁽²⁾									
	3-24-71-1 ⁽³⁾	200	282	165/240	145	2.9	1.18	74.2		
	3-26-71-3 ⁽⁴⁾	200	300	168/197	145	3.1	1.18	69.7		
-4	130					2.9	1.16	71.4		
-5	110					3.0	1.26	75.8		
B-36, 37 38 & 39	3-29-71-6	110	300	167/240	130	2.9	1.25	21.0		
	-5					110	2.9	1.19	20.9	
	-1				90	3.3	1.18	54.0		
	-3		200		110	3.1	1.19	49.5		
	-2				90	2.9	1.20	43.9		
	-7				130	4.6	1.21	64.9		
	-4				110	4.4	1.22	56.5		
	4-2-71-2	110	300	175-261	110	3.1	1.03	58.2		
	-5							3.1	1.03	51.3
	-8							3.0	1.03	47.1
	-10							3.0	1.04	54.9
	-12							3.1	1.03	57.7
	4-8-71-2	50	212	177/242	145	11.8	1.34	71.3		
-6	300					11.9	1.24	69.9		
-5				9.6	1.14	68.1				
B-40 & 41	4-12-71-3	110	300	173/243	110	2.9	1.34	60.3		
	4-16-71-6	200	300	177/232	145	2.6	1.40	81.0		
B-43 & 44	4-23-71-2	110	300	171/240	110	2.9	1.52	79.3		
	-9	200				2.8	1.52	75.6		
	-3	50		145	12.8	1.48	103.5			

- (1) Filament properties, 1" gauge length and 100%/min strain rate
 (2) 233M centipoise dope viscosity
 (3) 180M centipoise dope viscosity after thinning with solvent
 (4) ~~122M~~ centipoise dope viscosity after thinning with solvent

previous large scale run using 110-hole jets.

d. Drawing Evaluation. Since the criteria for good polymer are that the resulting yarn be both drawable and yield target properties, yarn from the single-stage 0.69 I.V. series was drawn in the first study (Table XXVI). Although target properties were not achieved, the levels obtained were good considering the starting properties (Table XXV). In addition, the yarn was observed to process over a wide range of temperatures without breakage, showing unusual stability, as demonstrated by the second draw study in Table XXVII.

The yarn spun from the single-stage 0.78-0.89 I.V. polymers was evaluated in the third draw study shown in Table XXVIII. While most of the results gave a poor, flat response, a significant improvement was observed on single-shoe drawing. Again, stability was quite apparent.

High tenacities can often be achieved by employing higher draw ratios. The 4.4 dpf was drawn at 3.2 and 3.6 draw ratios. Table XXIX does not demonstrate any improvement in filament physical properties with higher draw ratios.

The two-stage polymer yarns, and especially those prepared from "dry" dope, gave target as-spun and drawn properties as shown in Table XXVIII. The stability of this yarn was sufficient as to permit single shoe drawing as well. This yarn was further evaluated by drawing it on the tow line with continuous in-line washing, drying, and drawing to give target properties as shown below:

PBI TOW DRAWING TRIALS

Feed: 4-23-71-5, 6, 7 (600 fil)
Draw Ratio: 2.0
Take-up Speed: 60 m/min

<u>Shoe Temperatures</u>		<u>Physical Properties</u>			
<u>S₁</u>	<u>S₂</u>	<u>DPF</u>	<u>Ten, g/d</u>	<u>Elong, %</u>	<u>TE₂¹</u>
385	450	1.33	4.17	20.6	19.0
440	--	1.46	4.06	25.7	20.6

TABLE XXVI

PBI DRAW STUDY - I

Feed: 3-5-71-4 & 8 (400 fil)*
Draw Ratio: 2:1

<u>Shoe Temperatures</u>		<u>Take-up Speed, in/min.</u>	<u>Physical Properties</u>		
<u>S₁</u>	<u>S₂</u>		<u>DPF</u>	<u>Ten. g/d</u>	<u>Elong. %</u>
320°C.	420°C.	80	1.34	3.47	18.1
320	410	80	1.36	3.56	14.5
320	430	100	1.41	3.58	20.3
320	420	100	1.45	3.31	15.4

* Single-stage Polymer

TABLE XXVII

PBI DRAW STUDY - II

Feed: 3-5-71-4 & 5 (400 fil)*
 Draw Ratio: 1.8:1
 Take-up Speed: 73 m/min

<u>Shoe Temperature</u>		<u>Physical Properties</u>		
<u>S₁</u>	<u>S₂</u>	<u>DPF</u>	<u>Ten., g/d</u>	<u>Elong., %</u>
305	439	1.6	3.17	18.5
305	419	1.5	3.22	14.6
305	411	1.6	3.21	13.9
310	431	1.6	3.56	26.6
315	427	1.5	3.25	22.6
315	419	1.8	3.20	21.3
315	411	1.7	2.92	18.2
320	431	1.6	3.16	18.4
325	427	1.7	3.09	22.1
325	419	1.8	3.26	22.4
325	411	1.7	3.08	14.3
330	439	1.5	3.00	17.5
330	423	1.6	3.18	16.4
330	415	1.6	3.40	19.8
335	427	1.6	3.45	23.2
340	439	1.6	3.31	23.0
340	423	1.5	3.65	21.1
340	415	1.6	3.32	16.7

* Single-Stage Polymer

TABLE XXVIII
PBI DRAW STUDY - III

Shoe Temperatures		Physical Properties				
S_1	S_2	Color	DPF	Ten., g/d	Elong., %	TE^2
Feed: 3-29-71-1 (110 fil) * Draw Ratio: 2.3 Take-up Speed: 93.2 m/min						
320	423	Brown	1.3	3.10	10.3	10.0
320	439		1.4	2.95	16.0	11.8
400	---		1.4	3.15	18.7	13.6
406	---		1.5	3.01	19.3	13.2
412	---		1.3	2.69	16.1	10.8
Feed: 4-12-71-3 (110 fil) Draw Ratio: 2.0 Take-up Speed: 80 m/min						
330	415	Light	1.4	3.53	20.4	16.0
330	427	Brown	1.4	3.55	26.1	18.1
330	435		1.4	3.45	24.2	17.1
Feed: 4-23-71-1 (110 fil)						
330	427	Yellow	1.4	4.09	21.7	19.0
448	---		1.3	4.32	16.5	17.5
Feed: 4-23-71-9 (200 fil)						
330	427	Yellow	1.4	4.15	23.5	20.1

* Two-Stage Polymer

TABLE XXIX

PBI DRAW STUDY - IV

Feed: 3-29-71-4 (110 fil)^{*}
 Draw Ratio: 3.2:1
 Take-up Speed: 79 m/min

<u>S₁</u>	<u>S₂</u>	<u>DPF</u>	<u>Ten., g/d</u>	<u>Elong., %</u>
337	437	1.4	2.67	6.1
325	431	1.3	3.07	7.1
330	423	1.1	3.83	6.9
327	419	1.6	3.27	3.1
335	415	1.3	3.47	7.1

Draw Ratio: 3.6:1
 Take-up Speed: 90 m/min

325	431	1.2	2.31	2.9
330	423	1.3	2.99	4.6
335	415	1.4	3.73	10.5

* Two-Stage Polymer

The production operations were then initiated with the scale-up to 5000 fils on the tow line and production of 500 lbs of 1.5 dpf staple fiber as discussed in the DEMONSTRATION section.

10. TOW PROCESS

The proposed tow process is shown schematically in Figures 11 and 13. Bobbins of multifilament yarns were creeled to produce a 5000 filament tow which were then continuously fed to the washing, drying, and drawing stages. A Leesona winder was employed as the take-up mechanism to produce a 5 pound bobbin of yarn. The yarn was then crimped and cut for staple use. See Figures 14, 15, 16, and 17.

The tow equipment was installed and initial shake-down trials were conducted. A 2700 denier 1000 filament tow was processed through the wash tank at speeds of 40 and 50 m/min with DMAc analysis of < 0.01% on each sample. The same yarn was processed through the wash, dry, and draw assemblies in a continuous manner resulting in target properties at target speed. The shoe temperatures were staged.

TABLE XXX
TOW TRIALS - STAGED SHOES

Drying Oven °C	Feed m/min	Hot Shoes		Takeup m/min	Ten. g/d	Elong. %	TE _{1/2} ¹	Initial Modulus g/d
		S ₁ , °C	S ₂ , °C					
300	30	385	440	60	4.22	15.1	16.2	114
		390	450		3.98	21.9	18.6	102
	40	385	440	80	3.69	20.9	16.8	95.3
		390	450		100	4.12	17.9	17.4

A second run was made in which the shoes were not staged. The in-line drying oven temperature had to be raised to get any degree of drawing stability.

TABLE XXXI
TOW TRIALS - IDENTICAL SHOES

Drying Oven °C	Feed m/min	Hot Shoes		Takeup m/min	Draw Tens.	Ten. g/d	Elong. %	TE _{1/2} ¹	Initial Modulus g/d
		S ₁ , °C	S ₂ , °C						
500	30	420	420	60	275	4.11	11.2	13.8	128.3
		430	430		210	3.88	24.0	18.9	102.5
		440	440		185	3.71	20.8	16.9	95.5
		450	450		175	3.28	22.4	15.5	89.3
		460	460		150	3.21	23.3	15.5	83.7

FIGURE 13

PBI FIBER PROCESS

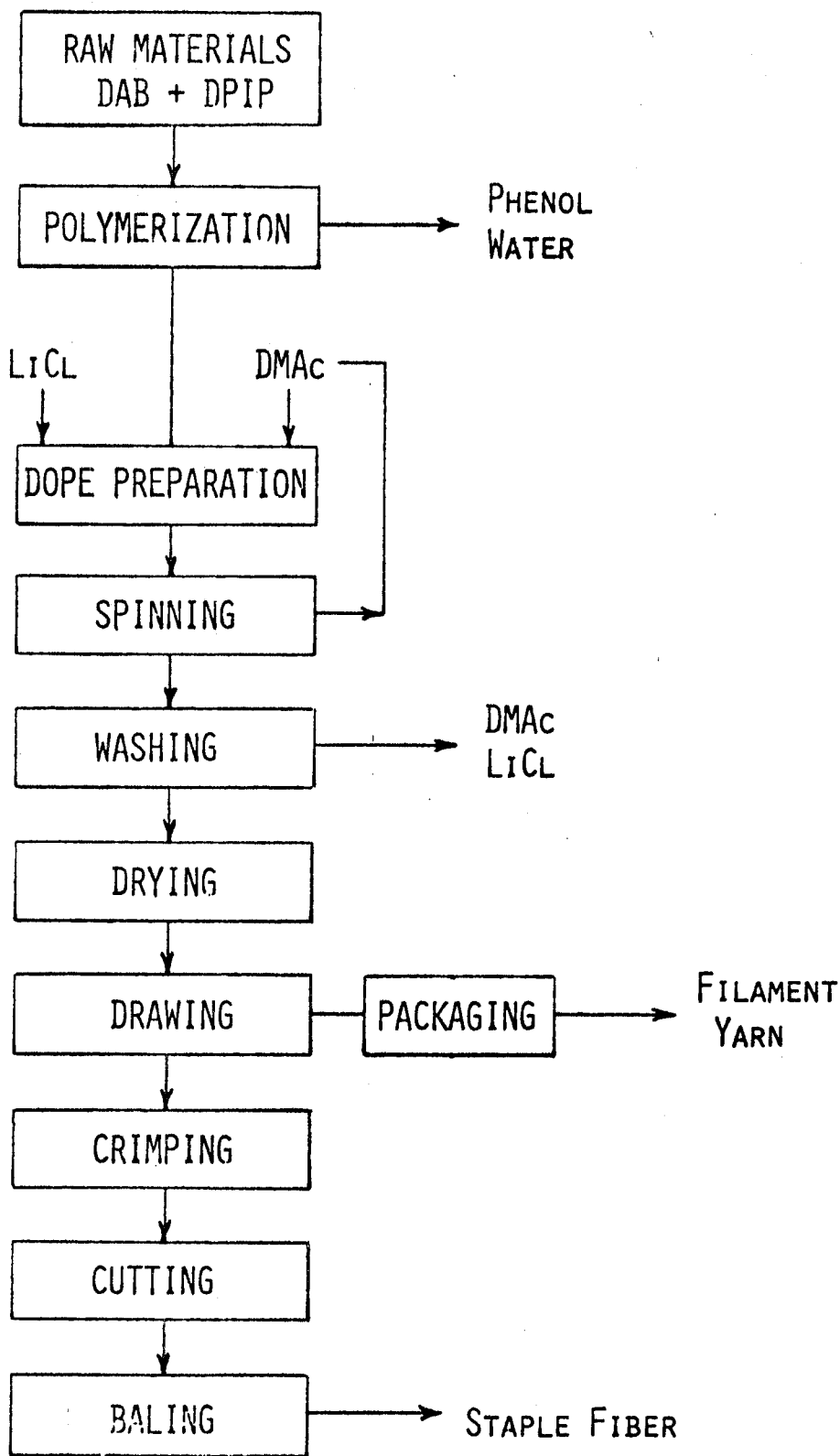

FIGURE 14

TOW PROCESS - 25 BOBBIN CREEL

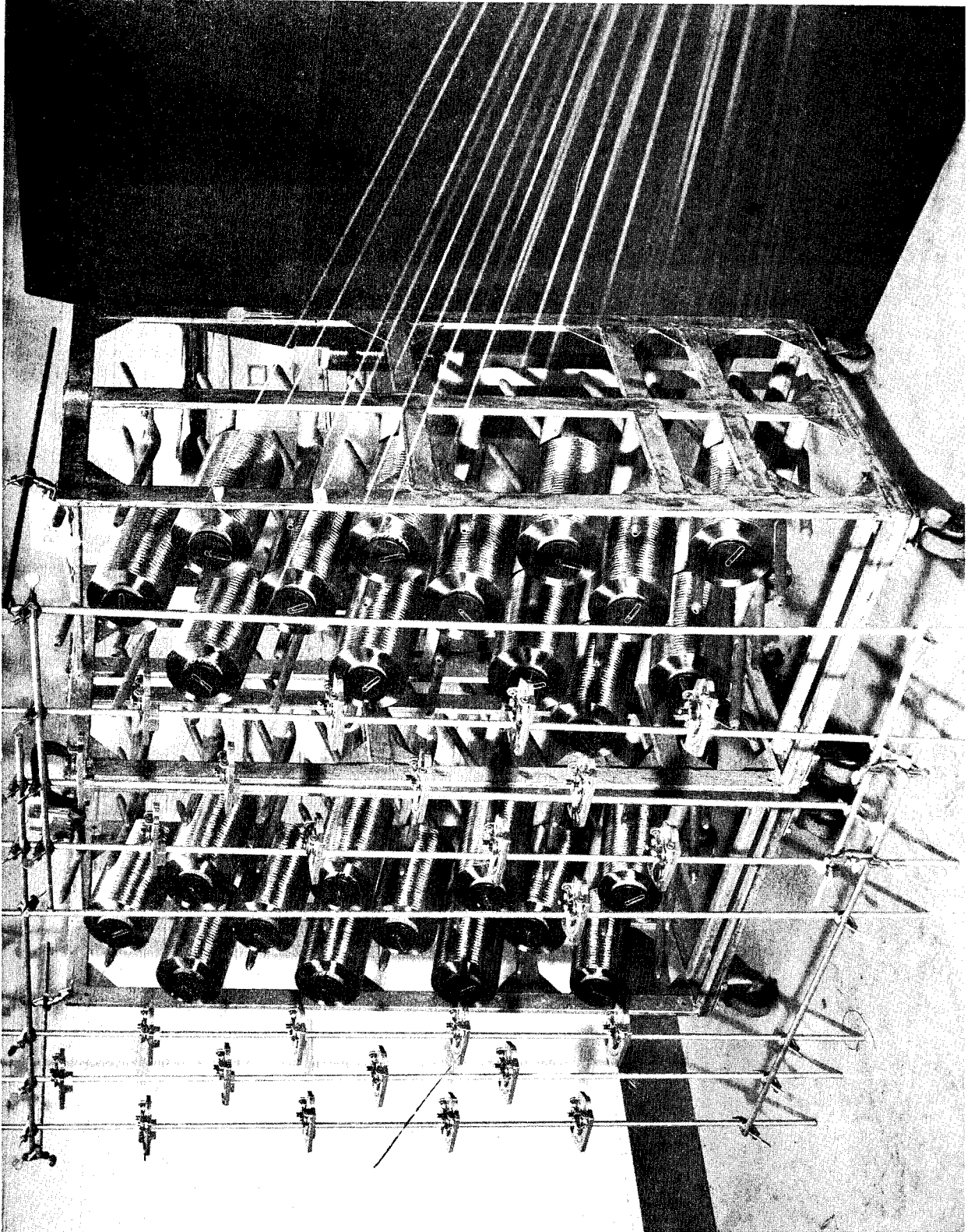

FIGURE 15

TOW PROCESS - CONTINUOUS WASH SYSTEM

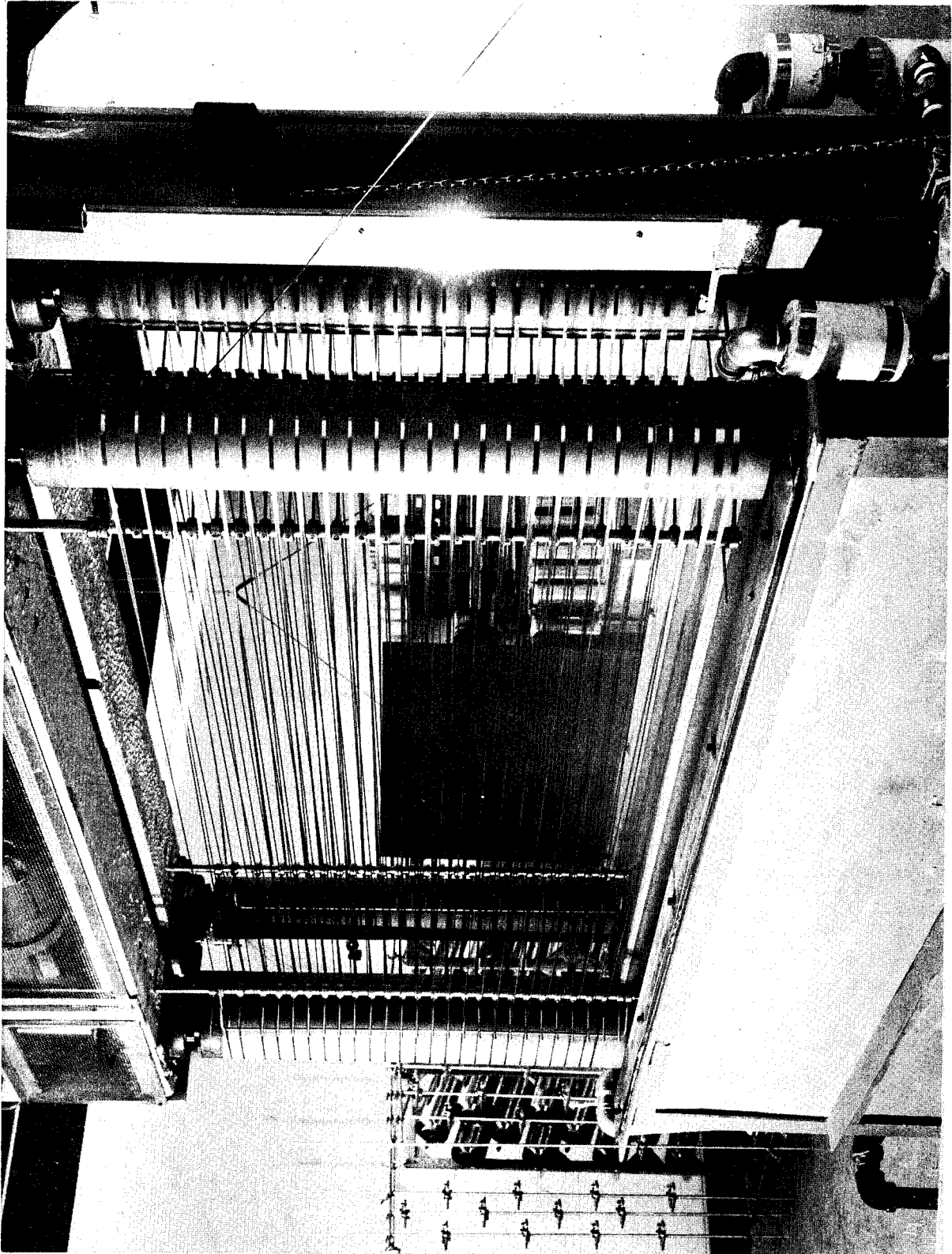

FIGURE 16

TOW PROCESS - CONTINUOUS DRYING SYSTEM

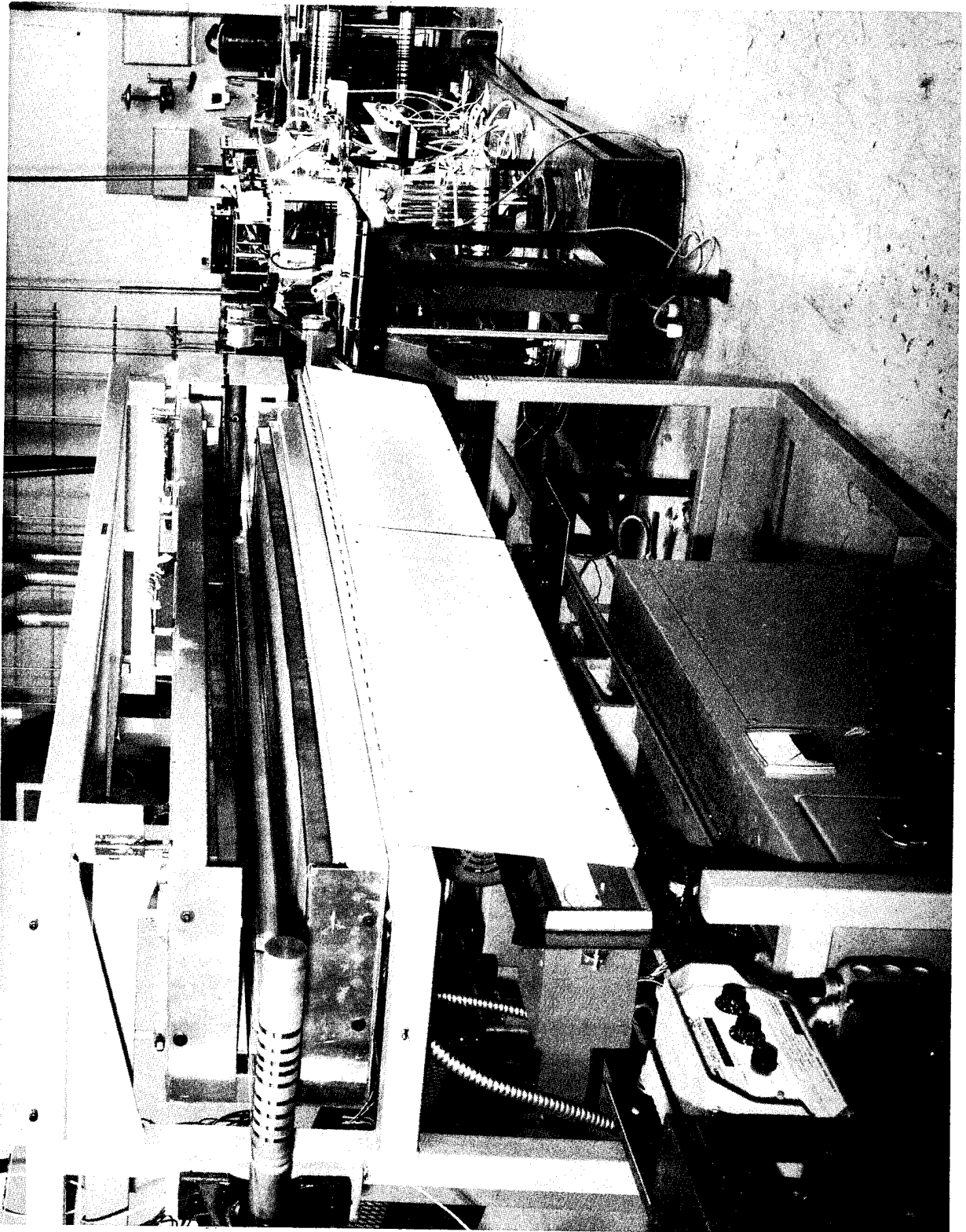
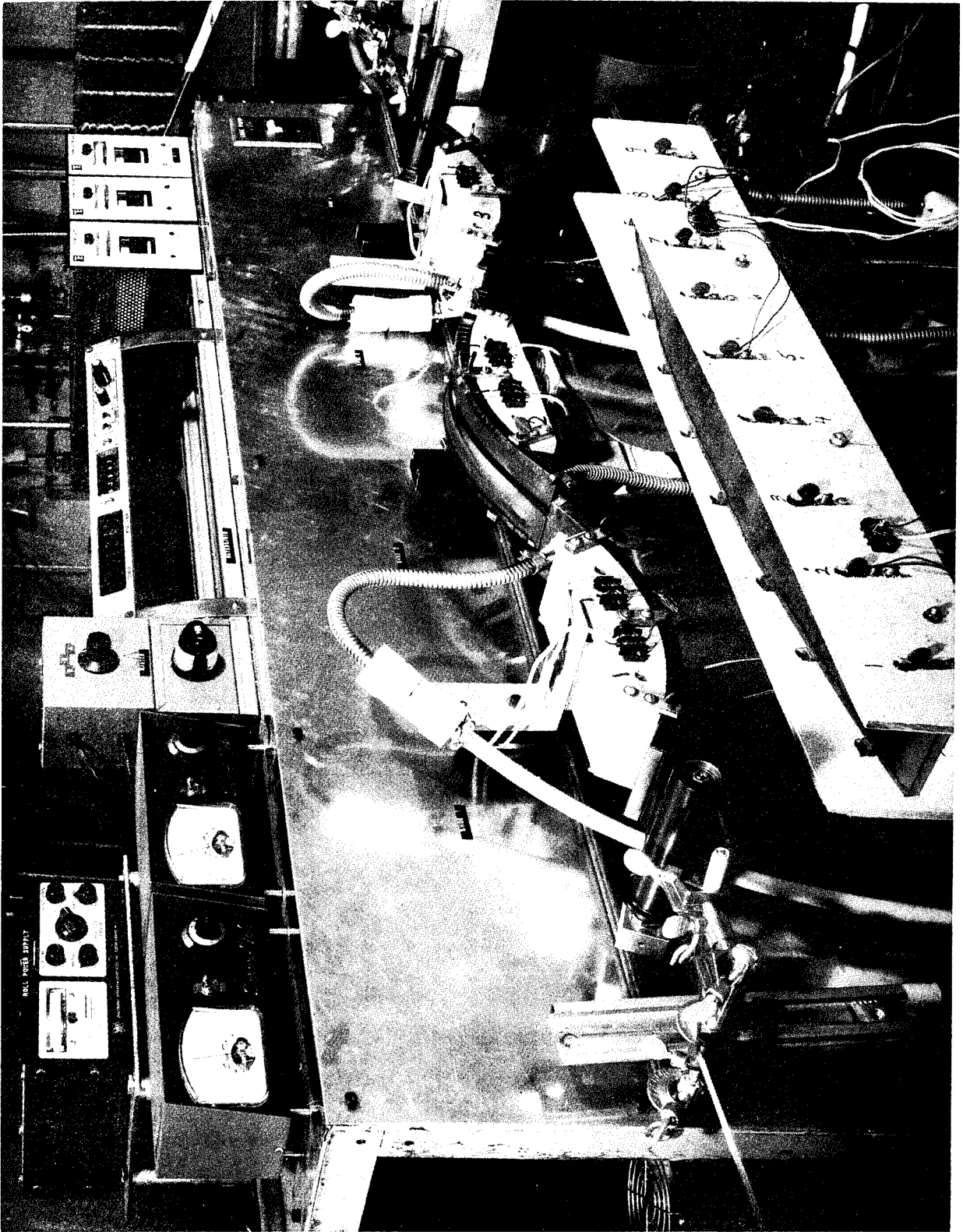

FIGURE 17

TOW PROCESS - HOT SHOE DRAWING SYSTEM



Note that both higher tenacity and initial modulus were obtained where more work was required to perform the draw. This is shown by the higher tensions recorded on the yarn between the second shoe and second roll. The properties in this trial with identical shoe temperatures are lower than those where staging was employed.

The effect of the drying oven temperature and degree of drying prior to the draw assembly was tested in the next run in which matched shoe temperatures were again employed at one level. Instability prevented the use of 50/100 m/min. The optimum drying oven temperature for 1000 fils appears to be 400°C as shown by the tensile factor ($TE_{\frac{1}{2}}$) in Table XXXII below:

TABLE XXXII
TOW TRIALS - OVEN TEMPERATURE

Oven °C	Feed m/min	Hot Shoes		Takeup m/min	Ten. g/d	Elong. %	$TE_{\frac{1}{2}}$
		S ₁ , °C	S ₂ , °C				
500	30	430	430	60	3.74	21.8	17.4
400					4.09	26.9	21.2
350					3.90	24.8	19.5
500	40			80	3.46	19.0	15.1
400					3.82	26.5	19.6
350					3.59	18.9	15.6

The yarn entering the in-line drying oven from the wash tank was observed to be extremely wet, more so than in the first trial which was somewhat nipped by the thread guide.

11. DEMONSTRATION

a. Summary. The polymerization, dope preparation, and spinning operations were performed for the tow demonstration without difficulty. The spun yarn was taken up on 5.5 lb packages without steam stretch.

Scale-up from 1000 to 5000 filaments on the tow line was performed with conditions being obtained at each level to yield target properties. Stability of processing was found to be dependent upon the speed and the size of the tow up to the temperature limits of the shoes. The 500 lbs of tow was processed at the 4000 to 5000 filament level. The lot average properties were 1.49 dpf, 4.16 g/d tenacity, and 22.8% elongation.

A total of 470 lbs of staple fiber and 30 lbs of tow were shipped in agreement with the Contract Project Engineer.

b. Polymerization. The polymer required for the demonstration run was made by the two-stage process without difficulty. The average I. V. level of 0.87 ± 0.03 demonstrated fine reproducibility.

c. Dope Preparation. All of the spinning dope required for the continuous spinning operation was prepared at 24% polymeric solids with 2% lithium chloride, based on the DMAc. An average dope viscosity at 30° C of 200,000 centipoise was achieved. G. C. analysis of the dope after the second stage filtration showed very low contaminant levels as demonstrated below:

TABLE XXXIII
DOPE ANALYSIS

Water	0.17 ± 0.03%
Acetic Acid	0.03
Phenol	0.09
Other Contaminants	0.12

d. Spinning. Additional spinnings with 200-hole jets and dope having a low water content demonstrated properties equivalent to that obtained in a previous large scale run using 110-hole jets. One of the most significant observations was that of the effect of tension on the "as spun" yarn during washing and drying. When the yarn is washed or dried in a loose state, it is free to relax and the elongation is enhanced at a loss of tenacity. When the yarn is fixed in length, the tenacity level is increased with a loss in elongation. This exchange in properties results in no change in the potential of the yarn as demonstrated by the tensile factors ($TE_{\frac{1}{2}}$) of the filaments as shown in Table XXXIV.

The conditions employed in the spinning demonstration run in which both columns were operated simultaneously to produce 5.5 lbs/hour are tabulated in Table XXXV. The required yarn for the tow demonstration was produced by these conditions, with a package time of two hours, weight of 5.5 lbs and without steam stretch.

e. Tow Processing. The initial trials with 2000 and 3000 fils with previous conditions were unsuccessful. The effect of drying temperature

TABLE XXXIV

EFFECT OF WASHING AND DRYING
CONDITIONS ON FIBER PROPERTIES

<u>Wash & Dry Method</u>	<u>Elongation %</u>	<u>Tenacity g/d</u>	<u>TE^{1/2}</u>	<u>Initial Modulus g/d</u>
Loose	117.7	1.32	14.4	20.0
Wound on bobbin loosely	105.0	1.42	14.6	21.5
Wound on bobbin with tension	80.5	1.57	14.2	33.2
Tow process with fixed length and tension	84.7	1.56	14.4	41.1

TABLE XXXV

PBI SPINNING CONDITIONS

Dope	
Polymer	24%
Lithium Chloride (on DMAc)	2%
Viscosity Range, centipoise @ 30°C.	175-250M
Jet	
Number of Holes	200
Size of Holes	100 μ
Temperatures, \pm 3°C.	
Candle Oil	145°C.
Jet Level Nitrogen	200
Column, Top	175
-	180
Middle	208
-	220
Bottom	238
Nitrogen Make-up	1.5 SCFH
Lube, Nopco 1296	1%
Take-up Speed	300 m/min
Steam Stretch	None
Package Time	2 hrs.
Package Weight	5.5 lbs.
Yarn Denier, Dry	600
Filament Denier, Dry	3.0

TABLE XXXVI

EFFECT OF DRYING TEMPERATURE ON UNDRAWN
AND DRAWN PROPERTIES - 1000 FILS

Wash °C	Dry Oven °C	Draw				Tension, g	Properties		
		Speed m/min		Shoes °C			Elong. %	Ten. g/d	TE $\frac{1}{2}$
		R ₁	R ₂	S ₁	S ₂				
90	400	30	-	-	-	-	80.0	1.47	13.2
90	400	30	60	385	445	200	28.4	3.92	20.9
90	450	30	-	-	-	-	80.5	1.56	14.0
90	450	30	60	385	445	150	26.3	4.03	20.7
90	500	30	-	-	-	-	84.7	1.56	14.4
90	500	30	60	385	445	150	21.6	4.10	19.0
90	570	30	-	-	-	-	71.0	1.59	13.4
90	570	30	60	385	445	150	25.4	3.98	20.1
90	630	30	-	-	-	-	63.9	1.90	15.2
90	630	30	60	385	445	200	26.5	4.32	22.2

TABLE XXXVII
TOW PROCESS CONDITIONS & RESULTS

Wash °C	Dry °C	Draw					Properties ¹		
		Speed, m/min		Shoes °C			Elong. %	Ten. g/d	TE ₂ ¹
		R ₁	R ₂	S ₁	S ₂	S ₃			
2000 FILS									
90	500	30	60	325	428	465	22.0	4.53	21.3
90	500	30	60	325	400	430	10.7	4.93	16.2
3000 FILS									
90	510	30	60	365	472	482	26.4	3.95	20.3
90	510	30	60	355	455	465	23.5	4.10	19.9
90	510	30	60	355	428	445	12.3	4.32	15.2
4000 FILS									
90	470	22.5	45	455	460	470	25.0	4.58	22.9
90	470	22.5	45	335	438	472	19.6	4.00	17.7
90	430	26.2	50	460	470	470	22.2	4.45	21.0
5000 FILS									
90	430	23.5	45	430	482	482	24.6	4.37	21.7
90	430	23.5	45	365	477	477	26.1	4.45	22.8

¹Filament properties on 5 breaks with 1" gauge length at 100% strain rate per minute.

TABLE XXXVIII

PBI TOW PROCESSING CONDITIONS

5000 fils

Washing Stage

Water Rate	2 gal/min
Water Temperature	90-95°C.
Residence Zone	200 meters
Yarn Tension, in	0.15 g/fil or 0.05 denier

Drying Stage

Oven Temperature	400-500°C.
Residence Zone	40 meters
Yarn Tension, in and out	0.20 g/fil or 0.08 denier

Drawing Stage

Feed Roll (R ₁), Speed	23.5 m/min
Shoe, Size	3" x 13"
Shoes, Number (S ₁ , S ₂ , S ₃)	3
Take-up Roll (R ₂), Speed	45 m/min
Draw Ratio	1.86
Lube, Nopco 1296	0.5%
Take-up Tension, Lessona	0.06 g/fil or 0.035 denier

on undrawn and drawn fiber properties was evaluated at 1000 fils. The data tabulated in Table XXXVI demonstrate that higher oven temperatures allow the yarn to yield under the tension applied at the dancer arms (speed control mechanism) and, therefore, a slight pre-draw exists to yield higher tenacity on the feed yarn to the draw zone. Higher temperatures result in a darkening of the yarn, therefore, more passes in the oven at a lower temperature, which also prevents the pre-draw, were employed in the scale-up to 5000 fils as shown in Table XXXVII.

The tow processing conditions for 5000 fils are given in Table XXXVIII. The crimping and cutting of the tow drawn yarn from the demonstration run was accomplished without difficulty.

Item 1AA of the contract consisting of 470 lbs of 1.5 dpf staple fiber, crimped and cut to 2" length as well as 30 lbs of tow on bobbins was shipped on schedule. The lot average properties were as shown below:

1.492 dpf
4.16 g/d tenacity
22.8 % elongation

12. PLANT DESIGN AND ECONOMICS

a. Summary. A preliminary design was made for a plant producing 800,000 lb/yr of PBI staple and 200,000 lbs/yr of PBI filament. Diaminobenzidine (DAB) purification equipment was omitted on the premise that purified DAB could be purchased. Instead of a cottonfield plant, a battery-limits plant at an existing location was assumed.

Production cost is highly dependent on the DAB cost and less so on the diphenyl isophthalate (DPIP) cost, neither of which is yet fully established for the quantities required. At a raw materials cost of \$5.00/lb for DAB and \$1.00/lb for DPIP, with depreciation over 5 years, the combined production costs are estimated at \$7.56/lb for staple and filament.

b. Process Design. In the current plant design, DAB purification facilities are not required since a suitable quality material would be purchased. The major operations are polymerization, dope preparation, spinning, and after-treating.

1. Polymerization. The polymerization section (Fig. 18) is not significantly different from previous designs. DAB would be transported from the manufacturer in rubber Sealdbins holding at least a 1-day

supply, each. These would be hoisted into position to feed by gravity into a weigh hopper. DPIP is transferred to a storage hopper by a nitrogen lift system. Three reactors are required, each preparing two batches per day. To attain batch temperatures of about 900°F, a molten salt is circulated through the reactor jackets. For cooling at the end of the cycle, the molten salt is drained, and cooling water is pumped through an attached coil (in the jacket) around the reactor.

When the reactors are depressurized, the phenol-water azeotrope is condensed and stored for disposal. During the latter half of the depressurization cycle the water is essentially all removed, and the phenol condensate is collected in a different drum for reuse in the next batch. It is assumed that the impure phenol will be hauled away for its chemical value, and no disposal facilities are required. The cooling water is tempered to 90°F to prevent freezing of the phenol in the condenser and lines. The phenol is cooled to 110°F, just above its freezing point.

The polymer is dumped from the bottom of the reactors, conveyed to a bucket elevator and lifted to a storage hopper.

2. Dope Preparation. Spinning dope is prepared once a day (Fig 19). PBI is weighed into the solutioner, and DMAc solvent is run in from a volumetric metering drum. LiCl, because of its slow rate of solution, is dissolved earlier in a separate vessel and added to the dope. Based on recent experience, only 1% LiCl on DMAc would be used.

Waste fiber can be dissolved in DMAc as long as it has not been drawn. Suitable fiber waste can be dissolved once per day, filtered and added to the dope. The dope is held in the solutioner until its solids content has been checked. It is then filtered into the dope storage vessel and continuously circulated through filters back to storage until used. One stage of dope filtration and storage has been eliminated from previous designs.

3. Staple Spinning. As shown in Figure 20, dope is pumped through a heater, filtered and spun into a co-current flow of heated nitrogen. 300-Hole jets are used with spinning rates of 300 m/min. Each column spins 1230 denier yarn (4.1 dpf) at 5.42 lb/hr. The output of all 24 columns is gathered into a tow and piddled into cans. The columns are heated by a common Dowtherm system with three temperature zones from 355°F at the top to 465°F at the bottom. A cooler is provided on each column feed to cool the dope when it is necessary to change spinnerets.

Each set of 4 columns has a separate nitrogen circulating system with DMAc condenser, blower and heater. To prevent any possibility of air leakage into the system causing an oxygen accumulation, 5% of the nitrogen circulation is continuously purged.

DMAc collected from the condensers is fed to a small distillation column where any degradation products are removed. It is then filtered, dried and reused.

4. Staple Processing. After-treatment is handled continuously. This differs from previous designs which included batch washing and drying. Tows are combined from a 20-can creel into one large tow of about 590,000 denier (Fig 21). This is fed at about 15 m/min to a series of counter-current wash troughs where residual DMAc is removed. Drying is accomplished by multiple passes over steam-heated rolls in a hot air oven.

The tow is spread and drawn (3:1) over electrically-heated hot shoes. Finish is added, and the tow is crimped, cut and baled.

5. Filament Spinning. In Figure 22 dope from the common circulating system is pumped through heaters and filters into the spinning columns. For filament, two 50-hole spinnerets are used in each column at 300 m/min spinning rates. Each of 8 columns produces two 540 denier yarns, each at 2.38 lb/hr, and the product is taken up on special perforated non-metallic bobbins.

The nitrogen circulation systems are similar to those in the staple spinning section. Condensed DMAc is collected and recovered in the common facilities.

6. Filament Processing. As shown in Figure 23 batch washing of filament is still the most feasible method. The yarn, on bobbins, is water washed in a pressurized counter-current batch system that switches the water flow sequence and does not involve moving the bobbins from tank to tank. The washed yarn is partially dried in a dielectric oven.

Ninety-six (96) ends are taken from a bobbin creel at 50 m/min, passed over steam-heated rolls to complete the drying and drawn (3:1) over electrically heated hot shoes. Finish is applied to the yarn, and the product is taken up on ring-twisters and packaged.

7. Pollution Aspects. Consideration has been given in the plant design to the elimination of pollution in the various effluents.

The purged nitrogen from the spinning columns will be vented through an existing flare. DMAc in the wash water is biodegradable and can be handled by a settling pond with sufficient hold-up time. As has already been noted, it is assumed that the excess phenol generated in the polymerization will be hauled away for its recovery value.

c. Economic Evaluation.

1. Basis of Estimate. A 1 MM lb/yr battery-limits PBI plant is assumed to be built at an existing location. Production would be on a three shift/day continuous basis, 334 days/yr. Daily production rate is 2400 lb of staple and 600 lbs of continuous filament.

2. Production Cost. The production costs calculated for staple and filament are shown in Table XXXIX.

Purified DAB has been previously purchased from Narmco (Division of Whittaker Corp) at \$31.65/lb. Obviously, in large quantities, this cost is not realistic. Since various processes and manufacturers are under consideration for the DAB, no firm cost can be established at this time. Accordingly, several levels of DAB raw material cost were used to establish its effect on PBI production cost (see Fig 24).

DPIP is now being purchased from Burdick and Jackson Laboratories at \$3.90/lb. Approximate calculations show that a process might produce DPIP for about \$1.00/lb from isophthalic acid and phenol.

No by-product credits were taken. Waste drawn filament is of a different denier than the staple, so it cannot be cut up for this use.

Labor and utility costs are given in Tables XL and XLI. Table XLII gives a breakdown of the manpower requirements. Labor costs include all benefits. Labor costs common to both products were apportioned 80% to staple and 20% to filament. Supervisory labor was apportioned equally to the products. Labor overhead and supplies were taken as 3% of labor costs.

Utility consumptions were kept separate for the two products. Those for common facilities were apportioned 80% to staple and 20% to filament.

Annual maintenance costs were assumed to be 5% of the fixed capital costs.

Factory general was 20% of total labor, utility and service, and maintenance costs.

For a plant of this type with the government as the only customer, normal depreciation over 12 years was considered too long. Depreciation over 5 years was used in this study.

Only production costs, rather than selling prices, were calculated. These are shown in Figure 24 as a function of DAB and DPIP raw material costs.

3. Capital Investment. The capital estimate is given in Table XLIII. Equipment lists with installed costs are given in Table XLIV. A Marshall-Stevens Index (MSI) of 299 was used.

Piping, instrumentation, insulation and electrical costs were taken as appropriate percentages of the total installed equipment cost. Engineering, construction and contractor fees are included as percentages of the total process equipment cost. Cost of land is not included.

d. Conclusions. Updating the design and economics has essentially confirmed the conclusions drawn from earlier work:

1. The biggest factor affecting production cost is the purchase price of DAB.
2. The DPIP cost, while not as much a factor as DAB, is still significant. If a reasonably low-cost material cannot be purchased, consideration should be given to making DPIP at the same plant using the evolved phenol as one of the raw materials.
3. Purchased nitrogen is the highest utility cost. If a nitrogen supply is not available at the location selected, a package nitrogen plant should be economically feasible.

SECTION IV

CONCLUSIONS AND RECOMMENDATIONS

1. POLYMERIZATION

- a. Delays in the fabrication, delivery, installation, and shake down of the single-stage reactor capable of 500°C and 500 psig were sufficient to substantially reduce the time available to fully optimize this process.
- b. Polymer was successfully produced by the single-stage process at the required production level with the desired inherent viscosity (IV).
- c. Processing conditions need to be defined that would permit single-stage polymerization at a lower temperature (e. g. 400° rather than 480°C) and still achieve molecular weight without forming gel or darkening the polymer.
- d. Because of the unreliability of the single-stage polymer with respect to yarn properties and the absence of time to correct these problems, two-stage polymer was prepared for the balance of the tow demonstration.

2. DOPE PREPARATION

- a. Modifications were made to the system to increase capacity and to permit full scale spinning on both columns simultaneously.
- b. The single-stage polymer exhibited a greater tendency to dissolve below the boiling point of the solvent indicating that pressure solutioning would not be required.
- c. The single-stage polymer exhibited a higher level of an insoluble portion (gel) when solutioned either at atmospheric (160°C) or under pressure (220°C) which readily plugged the first stage filter press reducing the throughput to one-sixth of normal.
- d. Low spun-yarn properties were correlated with a high moisture level in the dope. Target properties were again achieved when the LiCl was oven dried, caution was exercised against the polymer picking up moisture and the system was cleaned out.

3. SPINNING

- a. Higher filament deniers were spun (e. g. 4.5 as against 3.0) and drawn to give target properties which demonstrated one approach to higher spinning throughputs.

- b. Higher filament counts were also spun (e.g. 200 as against 110) increasing the spinning throughput. The number of holes was only limited by the size of the pilot equipment and 300 or more holes could be utilized in a commercial application.
- c. Jet starting techniques were substantially improved resulting in a minimum start-up time for both staple (high fil counts) or filament (low fil counts) applications.
- d. Steam stretching was determined to be unnecessary for staple processing and was eliminated.
- e. The DMAc recovered from the spin operation contains water and acetic acid. The requirements for recovery are desirable from an economic interest.
- f. Yarn from single-stage polymer exhibited lower properties and a darker color. This may not be a proper evaluation in that two-stage polymer also gave similar properties until the dope system was cleaned out and caution was taken against moisture.
- g. The spun yarn was taken up on large packages totaling 5.5 lbs. each.

4. WASHING

- a. A new analytical procedure for determining residual DMAc in PBI yarns was established which demonstrated a high degree of accuracy and reproducibility.
- b. Washing trials on yarn fed continuously to the system demonstrated removal of DMAc to below the 0.1% level with a 2 minute residence time.
- c. Instron tests provided additional design data for the construction of this stage for the tow process.

5. DRYING AND DRAWING

- a. Continuous drying of continuously washed yarn was accomplished with immediate drawing.
- b. A thermal process for the removal of DMAc from the spun yarn showed some merit, but only if the lithium chloride added to the dope could at some future time be eliminated.

6. TOW PROCESS AND DEMONSTRATION

- a. The tow system was designed, constructed and installed with target properties being obtained on the first trial with 1000 fils.
- b. While conditions were determined for increasing the tow size to 2000, 3000, 4000, and 5000 fils with attainment of target properties in each case, the operational stability of the draw zone decreased and shoe surface temperatures of up to 480°C were required. This instability on this apparatus is attributed to a function of the apparatus in not distributing the fils evenly on the shoe surface resulting in the "cold" drawing of some fils and occasional breaks of the yarn. Another system without skewed rolls should be evaluated for future scale-up.

7. PLANT DESIGN AND ECONOMICS

- a. A preliminary plant design was made for producing 1 MM lb/yr of PBI fiber of which 80% was staple fiber and 20% was continuous filament yarns.
- b. At a raw materials cost of \$5.00 and \$1.00 per pound for DAB and DPIP respectively, the production cost would be \$7.56/lb. of product.
- c. The biggest factor affecting production cost is the purchase price of DAB.

FIGURE 18

POLYMERIZATION
1 MM LB/YR PBI PLANT DESIGN

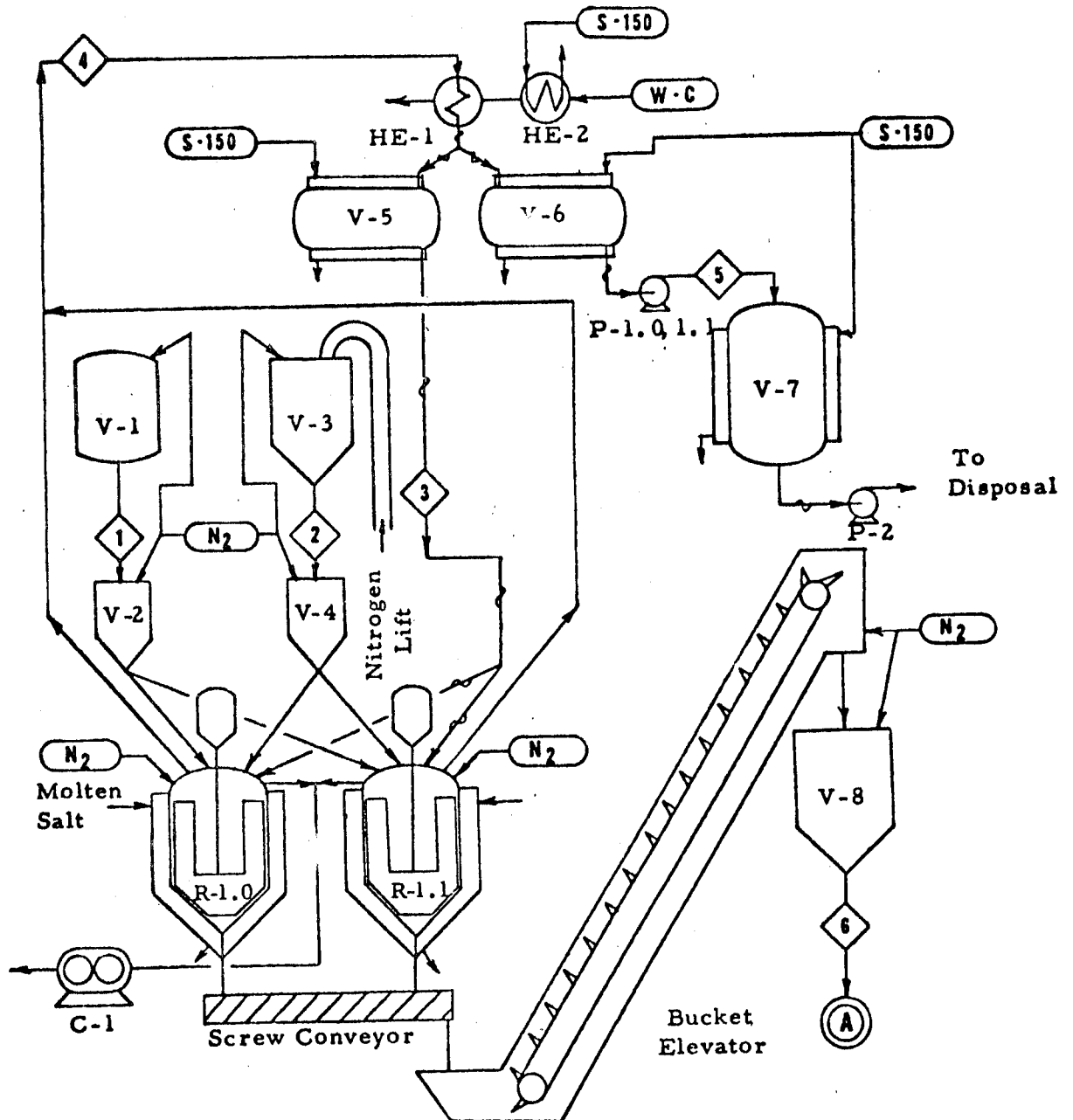

FLOW RATES - LB/DAY						
	1	2	3	4	5	6
Total	2,375	3,525	3,562	5,850	2,288	3,344
PBI						3,344
DAB	2,375					
DPIP		3,525				
Phenol			3,420	5,460	2,040	
H ₂ O			142	390	248	

-81-
FIGURE 19

DOPE PREPARATION
1 MM LB/YR PBI PLANT DESIGN

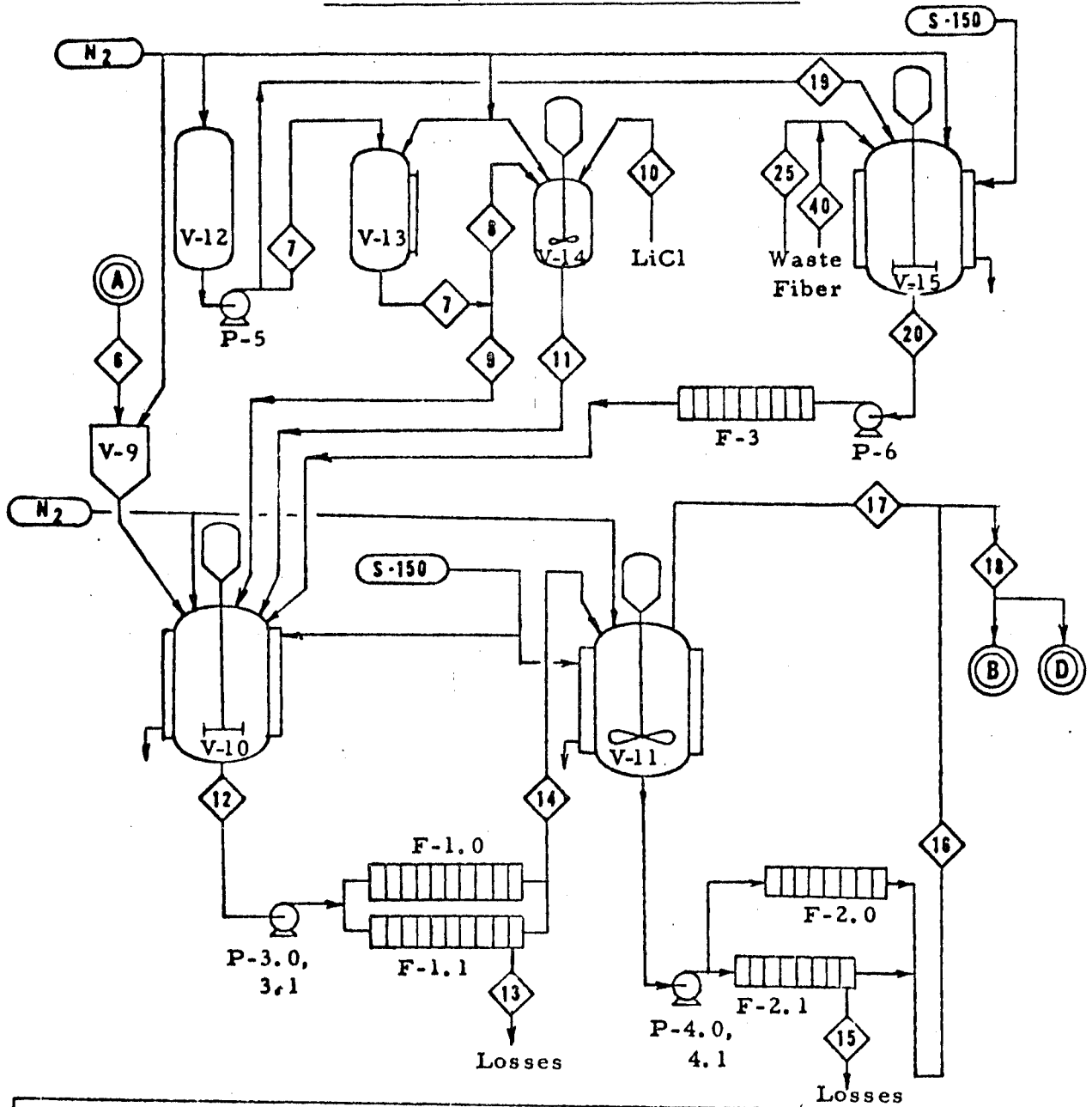

FLOW RATES - LB/DAY									
	6	7	8	9	10	11	12	13	14
Total	3,344	10,380	2,595	7,785	104	2,699	14,871	250	14,621
PBI	3,344						3,594	60	3,534
DMAc		10,380	2,595	7,785		2,595	11,165	188	10,977
LiCl					104	104	112	2	110

	15	16	17	18	19	20	25	40
Total	29	145,920	131,328	14,592	714	1,043	261	68
PBI	7	35,270	31,743	3,527		250	198	52
DMAc	22	109,550	98,595	10,955	714	785	57	14
LiCl		1,100	990	110		8	6	2

FIGURE 20

STAPLE SPINNING
1 MM LB/YR PBI PLANT DESIGN

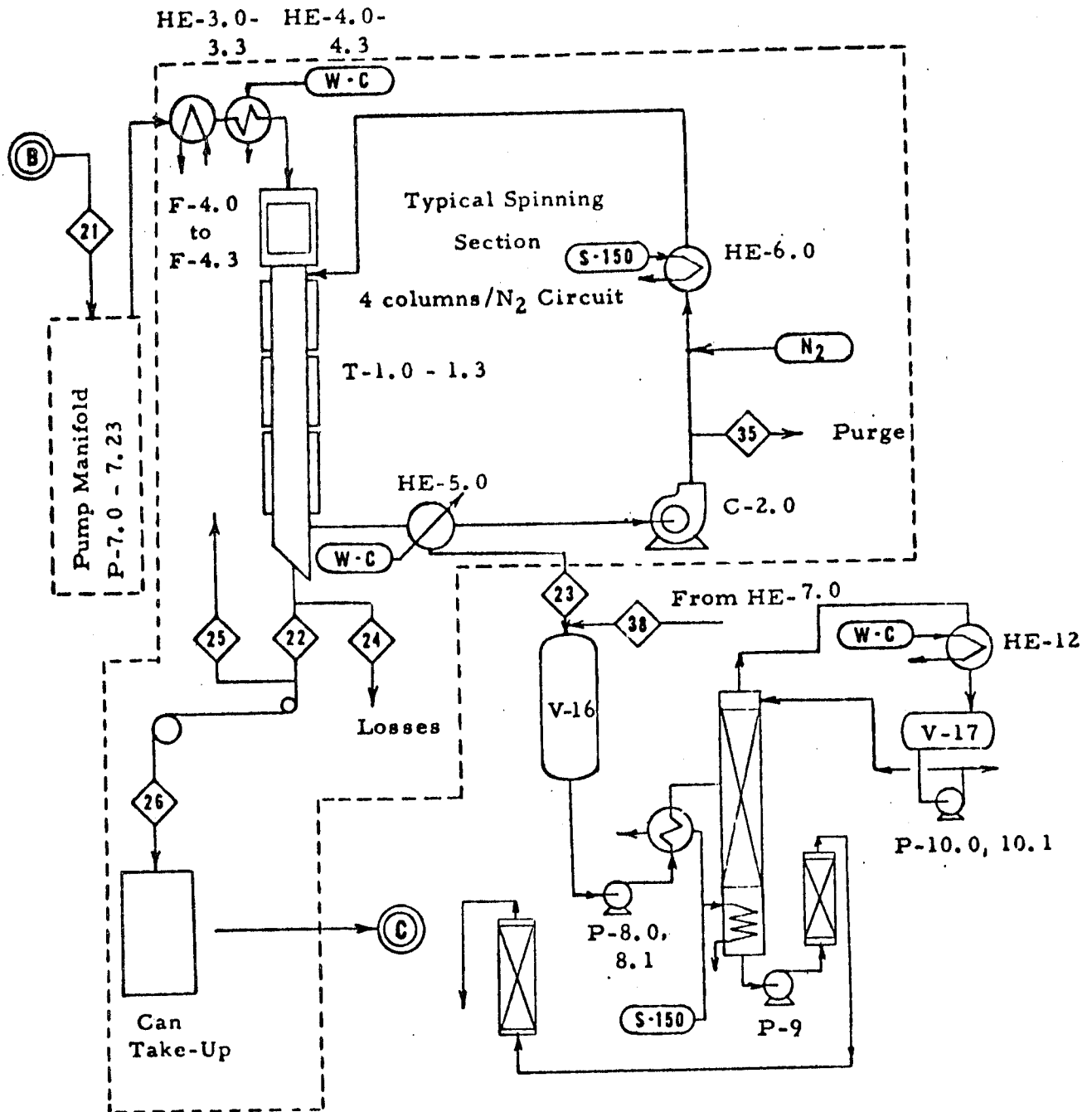

FLOW RATES - LB/DAY							
	21	22	23	24	25	26	35
Total	11,434	3,545	7,600	289	261	3,284	380
PBI	2,763	2,735		28	198	2,537	
DMAc	8,585	724	7,600	261	57	667	380
LiCl	86	86			6	80	

-84-
FIGURE 22

FILAMENT SPINNING
1 MM LB/YR PBI PLANT DESIGN

HE-7.0- HE-8.0-
7.3 8.3

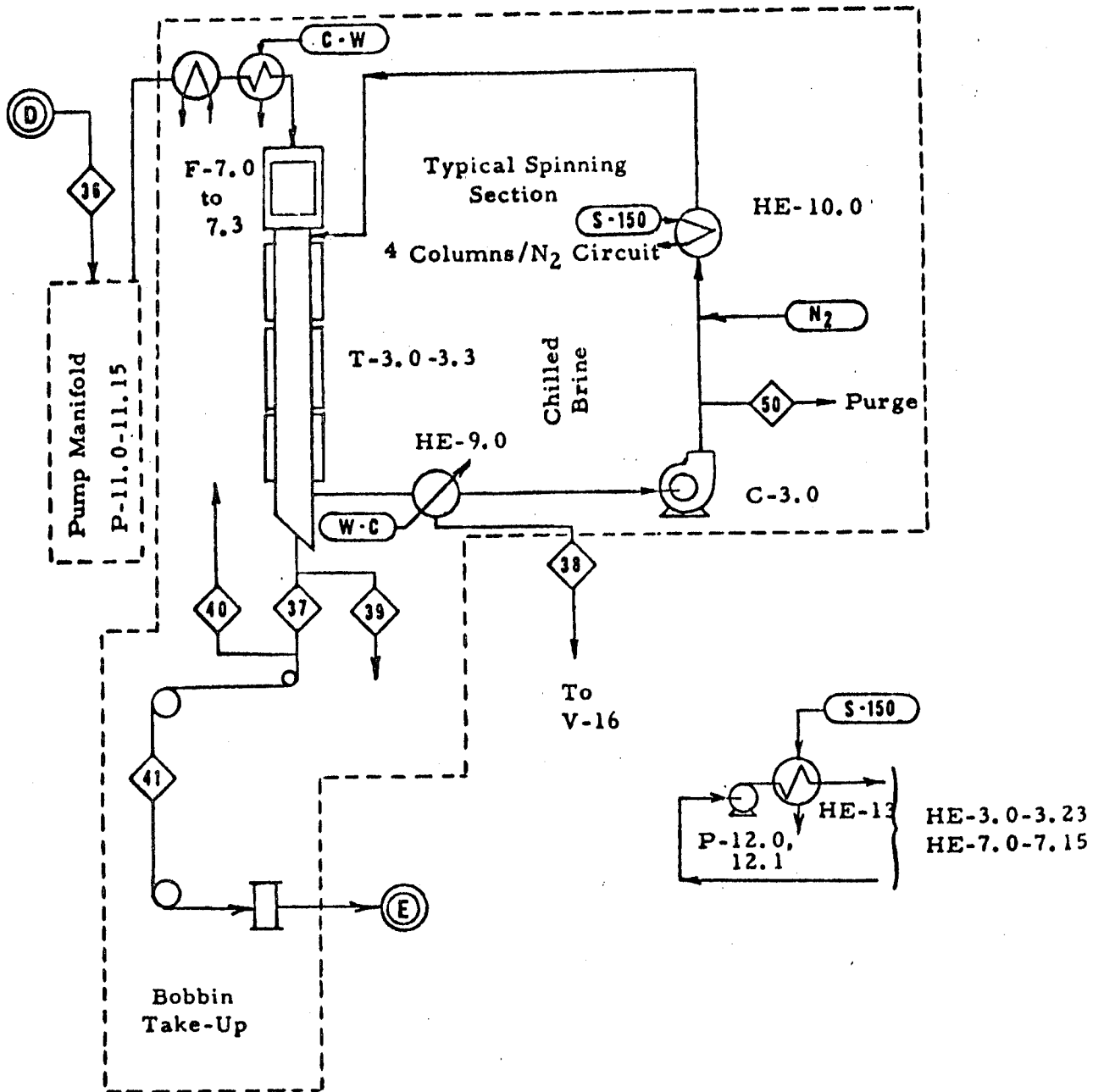

FLOW RATES - LB/DAY							
	36	37	38	39	40	41	50
Total	3,158	969	1,992	92	68	901	105
PBI	764	748		16	52	696	
DMAc	2,370	197	1,992	76	14	183	105
LiCl	24	24			2	22	

FIGURE 24

PRODUCTION COST

1 MM lb/yr Plant
DPIP assumed at \$1.00/lb
(Production cost varies 1.2¢/1.0¢ for DPIP)

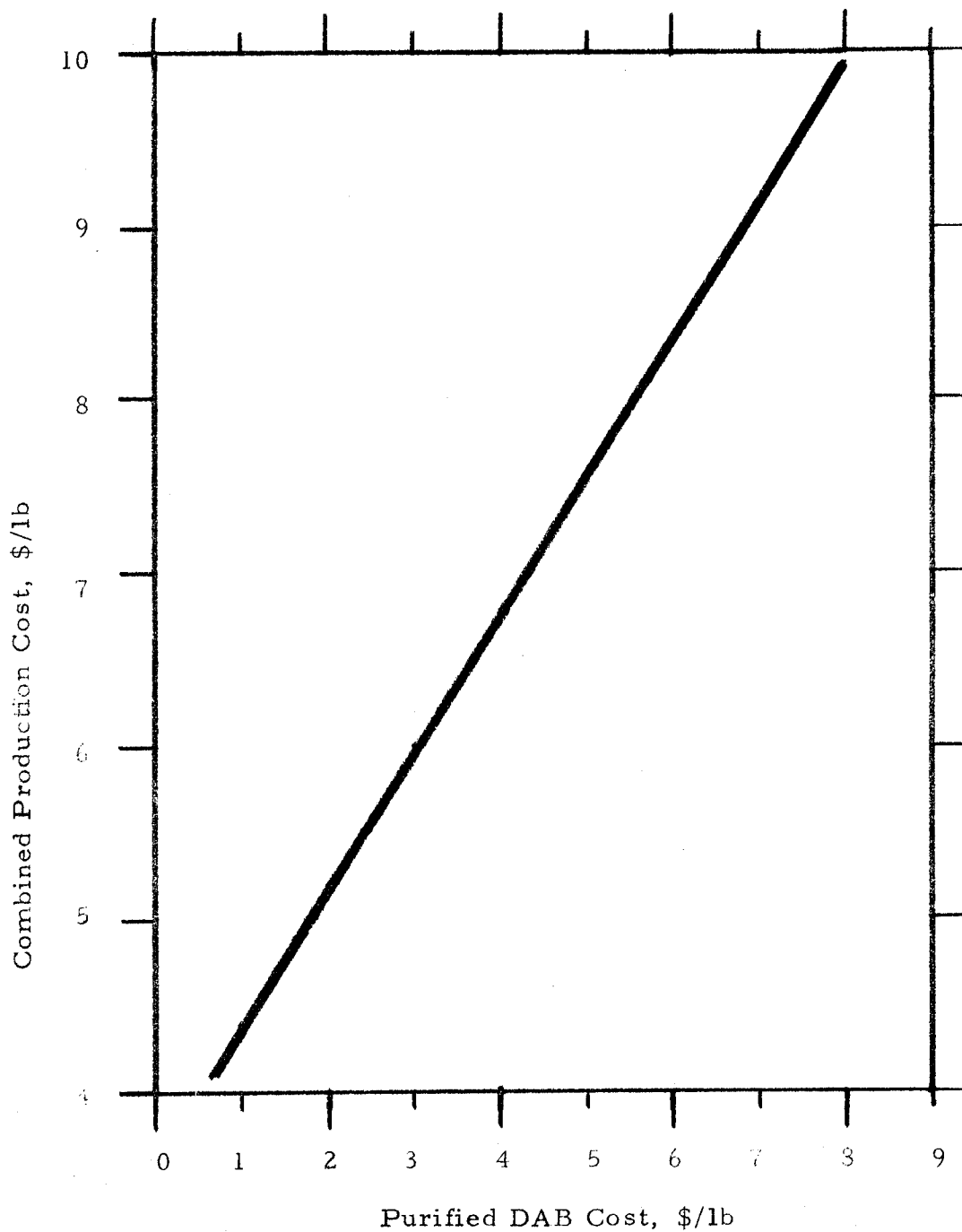

TABLE XXXIX

PLANT PRODUCTION COSTSRAW MATERIALS - STAPLE

<u>Item</u>	<u>Lb/Lb Prod.</u>	<u>\$/Unit</u>	<u>MM Units/Yr</u>	<u>¢/Lb Prod.</u>	<u>\$MM/Yr</u>
DAB	0.7756	5.00	0.620	387.5	3.1000
DPIP	1.1510	1.00	0.921	115.1	0.921
DMAc	0.6142	0.40	0.491	24.6	0.196
LiCl	0.0338	0.845	0.027	2.9	0.023
Finish	0.0038	0.50	0.003	0.2	0.002
RAW MATERIAL COST				530.3	4.242

RAW MATERIALS - FILAMENT

<u>Item</u>	<u>Lb/Lb Prod.</u>	<u>\$/Unit</u>	<u>MM Units/Yr</u>	<u>¢/Lb Prod.</u>	<u>\$MM/Yr</u>
DAB	0.8568	5.00	0.1714	428.5	0.857
DPIP	1.2715	1.00	0.2543	127.0	0.254
DMAc	0.6750	0.40	0.1350	27.0	0.054
LiCl	0.0374	0.845	0.0075	3.6	0.006
Finish	0.0033	0.50	0.0007	0.2	0.0003
RAW MATERIAL COST				585.9	1.171

TOTAL RAW MATERIAL COST

5.413

OPERATING COSTS

Total Labor Cost - Staple	34.2	0.274
- Filament	91.0	0.182
Total Utility & Service Cost - Staple	19.9	0.160
- Filament	24.6	0.049
Maintenance (5% of \$4, 153M)	25.8	0.258
Factory General (20% of Labor, U & S, Main.)	18.5	0.185
Depreciation (20% of \$5, 153M)	103.1	1.031
Packing Material	0.4	0.004
TOTAL OPERATING COST		2.143

PRODUCTION COST

7.556

TABLE XL

PLANT LABOR, UTILITY AND SERVICE COSTS

PBI STAPLE

Design Capacity: 800,000 lb/yr.

	<u>\$M/Yr.</u>
<u>LABOR</u>	
Operators: 30.2 at \$7,800/yr.	235.56
Shift Supervisors: 2.5 at \$9,200/yr.	23.00
Unit Superintendent: 0.5 at \$14,000/yr.	7.00
Labor, Overhead and Supplies (3% of above)	<u>7.97</u>
TOTAL LABOR COST	273.53

UTILITIES

	<u>Units/Yr.</u>	<u>\$/Unit</u>	<u>\$M/Yr.</u>
Steam - 150 psig	14,156 M lb.	0.75	10.62
Cooling Water	113,026 M gal.	0.05	5.65
Process Water	4,329 M gal.	0.10	0.43
Electricity	1,635,260 kwh	0.01	16.35
Fuel Gas	19,238 M scf	0.45	8.66
Nitrogen	65,410 M scf	1.80	<u>117.74</u>
TOTAL UTILITY COST			159.45

TABLE XLI

LABOR, UTILITY AND SERVICE COSTS

PBI FILAMENT

Design Capacity: 200,000 lb/yr.

	<u>\$M/Yr.</u>
<u>LABOR</u>	
Operators: 18.8 at \$7,800/yr.	146.64
Shift Supervisors: 2.5 at \$9,200/yr.	23.00
Unit Superintendent: 0.5 at \$14,000/yr.	7.00
Labor, Overhead and Supplies (3% of above)	<u>5.30</u>
TOTAL LABOR COST	181.94

UTILITIES

	<u>Units/Yr.</u>	<u>\$/Unit</u>	<u>\$M/Yr.</u>
Steam - 150 psig	4,104 M lb.	0.75	3.08
Cooling Water	36,072 M gal.	0.05	1.80
Process Water	1,442 M gal.	0.10	0.14
Electricity	641,280 kwh	0.01	6.41
Fuel Gas	4,810 M scf	0.45	2.16
Nitrogen	18,757 M scf	1.80	<u>35.56</u>
TOTAL UTILITY COST			49.15

TABLE XLII

PLANT MANPOWER REQUIREMENTS

	<u>Common</u>		<u>Staple</u>	<u>Filament</u>
	<u>Days Only</u>	<u>Shift</u>	<u>Shift</u>	<u>Shift</u>
Polymerization		2		
Dope Preparation	2			
Spinning			0.6	0.4
Change and Move Bobbins				1
Change and Move Cans			0.5	
After-treatment			1.5	2
Baling, Packaging			1	
General Utility		2		
	<u>2</u>	<u>4</u>	<u>3.6</u>	<u>3.4</u>

Annual Labor Required:

Common (shift)	4 x 4.2*	17
Staple (shift)	3.6 x 4.2*	15
Filament (shift)	3.4 x 4.2*	<u>15</u>

Total Shift Workers 47

Days Only Workers 2

49 Man Yrs.

Apportioning Common (80% Staple, 20% Filament):

Staple Labor 30.2 Man Yrs.

Filament Labor 18.8 Man Yrs.

Supervision (Apportioned Equally to Staple & Filament):

Shift Foremen 5

Area Superintendent 1

* Factor allowing for shift scheduling, vacations, etc.

TABLE XLIII

PLANT CAPITAL ESTIMATE

<u>Item</u>	<u>Estimated Installed Cost</u>
Polymerization	287,000
Dope Preparation	251,600
Staple Spinning	211,200
Staple Processing	216,300
Filament Spinning	122,300
Filament Processing	271,000
DMAc Recovery	165,000
Waste Treatment	125,000
Common Equipment	<u>42,600</u>
Total Installed Cost of Equipment (I. C.)	1,692,000
Total Installed Cost of Equipment (I. C.)	1,692,000
Piping, Battery Limits (0.50 I. C.)	846,000
Instrumentation (0.20 I. C.)	338,000
Insulation and Painting (0.15 I. C.)	254,000
Foundations and Concrete Pads (0.06 I. C.)	102,000
Electrical (0.25 I. C.)	<u>423,000</u>
TOTAL	3,655,000
Total Process Equipment (T. P. E.)	3,655,000
Engineering Fee (.15 T. P. E.)	560,000
Construction & Contractors' Fees (.15 T. P. E.)	584,000
Utilities and Services (.10 T. P. E.)	<u>366,000</u>
TOTAL FIXED CAPITAL (EXCLUDING BLDG)	5,153,000
TOTAL BUILDING COSTS	758,000
TOTAL FIXED CAPITAL WITH BUILDING	5,911,000
Sales Taxes on \$2,780,000 Purchased Equipment (Not Capitalized)	95,000

TABLE XLIV

PLANT EQUIPMENT LIST
1 MM LB/YR

<u>Item</u>	<u>Description</u>	<u>Size</u>	<u>Quantity</u>	<u>Install. Cost, \$</u>
POLYMERIZATION				
V-1.0	-DAB Sealed Bins w/Load and Unload Devices	600 gal	24	48,000
V-2	-DAB Weigh Hopper, CS	100 gal	1	400
V-3	-DPIP Storage Hopper, CS	100 gal	1	200
V-4	-DAB Weigh Hopper, CS	100 gal	1	400
V-5	-Phenol Recycle Drum, SS	250 gal	1	3,000
V-6	-Phenol Cond. Drum, SS	150 gal	1	2,000
V-7	-Phenol Waste Tank, SS	1600 gal	1	6,000
V-8	-PBI Storage Hopper, SS	1400 gal	1	6,000
R-1.0	-Polymerization Reactors, SS, High Temp & Pressure	250 gal	3	105,000
HE-1, -2	-Phenol/Water Condenser, SS	50 ft ²	1	7,500
C-1	-Vacuum Pump, SS	20 SCFM		2,500
P-1.0	-Phenol Cond. Pumps, SS	1 GPM	2	1,400
P-2.0	-Phenol Waste Pumps, SS	50 GPM	2	1,600
	-Monorail, Sealed Bin System			10,000
	-Bucket Conveyor			6,000
	-Screw Conveyor			10,000
	-Weigh System, V-2 and -4 Hopper			7,000
	-Drum Heating System			5,000
	-Molten Salt System			<u>60,000</u>
			TOTAL	287,000
DOPE PREPARATION				
V-9	-PBI Weigh Hopper, SS	700 gal	1	3,600
V-10	-PBI Solutioner w/Agitator, SS	2000 gal	1	26,000
V-11	-Dope Storage w/Agitator, SS	2000 gal	1	23,000
V-13	-DMAc Metering Tank, SS	1750 gal	1	7,000
V-14	-LiCl Solutioner w/Agitator	350 gal	1	6,000
V-15	-Waste Fiber Resolutioner w/Agitator, SS	700 gal	1	8,500
P-3.0	-Dope Pumps, SS	5 GPM	2	7,000
P-4.0	-Dope Circ. Pumps, SS	15 GPM	2	9,000
P-5.0	-DMAc Pumps, SS	5 GPM	1	7,000
P-6.0	-Dope Pumps, SS	2 GPM	2	3,000
F-1	-Primary Filter, P&F, SS	600 ft ²	1	36,000
F-2.0	-Secondary Filter, P&F, SS	750 ft ²	2	88,000

TABLE XLIV (CONTINUED)

F-3	-Fiber Filter, P&F, SS	25 ft ²	1	4,500
	-Exhaust Facilities			2,000
	-Ventilation Hoods over Filters/ Ducting			10,000
	-Waste Filter Dressing Tank, etc.			5,000
	-LiCl/DMAc Metering Pump			3,000
	-Weigh System for V-9 Hopper			3,000
				<u>251,600</u>

STAPLE SPINNING

T-1.0	-Spinning Columns, SS	8" dia x 20'	24	110,000
HE-3.0	-Dope Heaters, SS	1.5 ft ²	24	6,000
HE-4.0	-Dope Coolers, SS	1.0 ft ²	24	4,000
HE-5.0	-DMAc Condenser, SS	20 ft ²	6	11,500
HE-6.0	-Nitrogen Heater, CS	12 ft ²	6	5,900
P-7.0	-Dope Metering Pumps, SS	0.05 GPM	24	10,000
F-4.0	-Candle Filters, SS		24	7,500
C-2.0	-Centrifugal Blower, CS	220 SCFM	6	9,000
	-Spinning Jets		150	7,500
	-Can Takeup System, w/Feed Roll, Plates and Finish Applicator			10,000
	-Aluminum Cans	55 gal	50	1,300
	-Waste Yarn Transports		3	1,000
	-End Out Detector			5,000
	-Hot Oil System	500 MBTU/ hr	3	<u>22,500</u>
				211,200

FILAMENT SPINNING

T-3.0	-Spinning Columns, SS	8" dia x 20'	8	35,500
HE-7.0	-Dope Heaters, SS	1.5 ft ²	16	4,500
HE-8.0	-Dope Coolers, SS	1.0 ft ²	16	3,000
HE-9.0	-DMAc Condensers, SS	20 ft ²	2	4,300
HE-10.0	-Nitrogen Heaters, CS	12 ft ²	2	2,000
P-11.0	-Dope Metering Pumps, SS	0.05 GPM	16	7,000
F-7.0	-Candle Filters, SS		16	5,000
C-3.0	-Centrifugal Blower, CS	220 SCFM	2	3,000
	-Exhaust Blower, CS	3200 SCFM	1	1,000
	-Spinning Jets		100	5,000
	-Leeson & Bobbin Takeup, w/Steam Tube and Finish Applicator			24,000

TABLE XLIV (CONTINUED)

-Perforated Bobbins, Non-Metal		3500	10,000
-Bobbin Transports		15	4,500
-Hot Oil System	250 MBTU/ hr	3	13,500
			<u>122,300</u>

STAPLE PROCESSING

-Can Creel, 20 cans/creel		2	1,500
-Tow Washing Machine, w/Sumps and Multistage Pumps		1	62,000
-Tow Drier, w/Recirc. Blower		1	25,000
-Hot Shoe Draw Frame and Rolls		1	30,000
-Crimper		1	25,000
-Cutter		1	32,000
-Condenser and Baler, w/Blower		1	40,000
-Blower, CS	1200 SCFM	1	<u>800</u>
			216,300
-Pressure Wash Unit, w/Tanks, Pumps and Heaters		1	80,000
-Filament Bobbin Dryer		1	81,000
-Modified Draw Twister w/Contact Heaters and Finish Applicator		1	90,000
-Product Packing Station, w/Case Dolly; Scales, Labeling Machine		1	<u>20,000</u>
			271,000

DMAc RECOVERY

V-12	-DMAc Storage, SS, w/Underground Installation	20,000 gal	1	60,000
V-16	-DMAc Condensate Tanks, SS	500 gal	1	7,000
V-17	-DMAc Recovery Tank, SS	500 gal	1	7,000
P-8.0- 9.0-10.0	-DMAc Recovery Pumps	20 GPM	6	17,000
	-DMAc Recovery, Main Still, SS	12"dia x 80'	1	27,500
	-DMAc Recovery, Stripper	12"dia x 40'	1	19,000
	-DMAc Main Still Reboiler	100 ft ²	1	3,500
	-DMAc Stripper Reboiler	80 ft ²	1	3,500
HE-12	-DMAc Condenser	80 ft ²	1	3,500
	-Barometric Condenser System		1	3,000
	-DMAc Unloading System		1	<u>14,000</u>
				165,000

TABLE XLIV (CONTINUED)

WASTE TREATMENT

-Waste Phenol Incinerator System	25 GPH	35,000
Skid Mounted w/Pump and Controls		
-Waste Treatment System w/Total		75,000
Effluent Not to Exceed 100 GPM		
-Scrubber System, CS, w/Pumps	10'dia x 10'	15,000
and 500 gal Sump		
		<hr/>
		125,000

COMMON EQUIPMENT

-Electric Fork Truck, w/Charging		10,000
System, 2 Ton Capacity		
-Hand Truck, Pallets, Chain Falls		2,500
-Plant Office Furniture and Equip.		5,100
-Testing Equipment for Finished		25,000
Product and Raw Materials		
		<hr/>
		42,600

BUILDING COSTS (Building Area 25,500 ft²)

-Structural Steel, 16lb/ft ² x 25,500 ft ²		75,000
x \$370/Ton		
-Plumbing		100,000
-Electrical		108,000
-HVA/C		35,000
-Siding, \$0.50/ft ² x 26,000 ft ²		13,000
-Roof, \$1.50/ft ² x 12,500 ft ²		19,000
-Ground Slab, \$0.70/ft ² x 12,500 ft ²		9,000
-Elevated Slabs, \$0.90/ft ² x 12,500 ft ²		11,000
-Fire Protection System		35,000
		<hr/>
		505,000
-Engineering Fee, 0.15 x Subtotal		75,800
-Construction Fee, 0.15 x Subtotal		75,800
-Contingencies, 0.20 x Subtotal		101,000
		<hr/>
TOTAL BUILDING COST		757,600

APPENDIX I

PBI SINGLE - STAGE POLYMERIZATION
STANDARD OPERATING PROCEDURES

I. PRE-HEAT PROCEDURES:

1. _____ Turn (D-7) on to heat salt valves and lines.

_____ Set multi-point recorder to automatic and set chart speed to $7\frac{1}{2}$.

_____ Check high temperature fail-safe. Record below temperatures R3 from recorder and convert to °F and on C-4. Then slowly turn dial on (C-10) down until alarm and lights are activated. Push button (C-7) to stop alarm and record indicated temperature below. The temperatures in °F should be within 30° of each other:

R3: _____ °C; _____ °F C-10: _____ °F C-4: _____ °F

_____ Turn on pump blower (C-6), if it has not been left on.

_____ Set controls (C-9) to 475°F and (C-10) to 950°F.

_____ Push button (C-14) to reset the system.

_____ Turn (C-4) switch on and set to 475°F, if it has not been left on.

_____ Turn (C-13) to low, if it has not been left on.

Proceed to part IV of the last run.

2. _____ Two hours after step 1. above, close salt valves (V-8.2 and -8.3).
CHECK TO MAKE SURE - A MISTAKE HERE WOULD BE COSTLY.

_____ Turn (D-7) off.

Proceed to part III.

II. RUN PREPARATION PROCEDURES:

Clean out reactor vent line by performing the following:

1. _____ Attach water assembly to union fitting at point A.
_____ Open valves (V-1.0 and -1.1) as required and back flush venting system, draining occasionally to T-1.
_____ Remove water assembly at point A upon completion of back flushing.
_____ Empty T-1 by opening valve (V-1.3 and -2.9) and closing (V-2.7) located behind TCR.
_____ Turn on pump switch (PS-1) to empty T-1 to waste drum.
_____ When T-1 is empty, turn off (PS-1).
_____ Close valves (V-1.3 and -2.9) and open (V-2.7).

Charge and purge reactor by performing the following:

2. _____ Replace and secure bottom flange with gasket making sure all contact surfaces are clean.
_____ Charge _____ lbs. of DAB through the fill port using the exhaust trunk, face mask, and rubber gloves.
_____ Charge _____ lbs. of DPIP through the fill port using the exhaust trunk, face mask, and rubber gloves.
3. _____ Replace and secure the fill port flange with gasket making sure all contact surfaces are clean.
_____ Vacuum up any spillages around that port.
_____ Close vent valves (V-1.0 and -1.1).
_____ Close pressure gage valve (V-6.0).
_____ Close vent valve (V-2.1) on the phenol line.
4. _____ Start vacuum switch (VS-1) and crack vacuum valve (V-4.0) on head of reactor. Make vacuum check by closing (V-4.0) and

II CONTINUED

recording loss below with time. Repeat if necessary after tightening flanges or head valves. A good seal is required.

<u>Minutes</u>	<u>Vac.</u>	<u>Vac.</u>	<u>Vac.</u>	<u>Vac.</u>	<u>Vac.</u>	<u>Vac.</u>	<u>Vac.</u>
0							
1							
2							
3							
4							
5							

_____ When the above is satisfied, turn nitrogen regulator (V-7.5) up to its maximum setting.

_____ Open valve (V-7.1) to fill reactor to 2 psig on (PG-2).

5. _____ Close valve (V-7.0). End of first purge.

_____ Open vent valve (V-1.1) sufficiently to drop (PG-2) to zero.

_____ Open phenol valve (V-2.0) and throttle (V-2.2) to charge _____ lbs. from T-2 to Reactor. Close (V-2.2).

_____ Close valve (V-1.1).

_____ Open vent valve (V-2.1) and close valve (V-2.0).

_____ Throttle valve (V-4.0) open to pull a vacuum and then close (V-4.0).

_____ Open valve (V-7.1) to fill reactor to 2 psig on (PG-2).

6. _____ Close valve (V-7.0). End of second purge.

_____ Throttle valve (V-4.0) open to pull a vacuum and then close (V-4.0).

_____ Open valve (V-7.0) to fill reactor to 2 psig on (PG-2) and then immediately turn regulator (V-7.5) down to 15 psig. End of third purge.

_____ Turn off vacuum pump (VS-1).

_____ Check that water is flowing through water valve (V-3.0) to the packing gland.

III. RUN OPERATING PROCEDURES:

When parts I and II of the Standard Operating Procedures have been completed the run may be initiated as follows:

1. _____ Notify the Operations Supervisor as to the readiness of the polymerization system for this run.

2. _____ Final adjustments as follows:
 - _____ Open vent valve (V-1.1) half way.
 - _____ Close nitrogen valve (V-7.1) and set rotometer (V-7.4) at 10 SCFH.
 - _____ Close pressure gauge valve (V-5.0) and open valve (V-6.0).
 - _____ Set control (C-9) at 375° F.

3. _____ Turn on (D-1 and -2) and set (C-1) to _____° C and (C-2) to _____° C.
 - _____ Turn on (D-3) and set (C-3) to _____° C.
 - _____ Set (C-4) to _____° F and (C-4A) to _____° C.
 - _____ When batch (R1) reaches 50° C turn on agitator disconnect switch (D-5) and then push start button on agitator switch (AS-1) in a "start-stop" manner and then leave on. Set at 50 RPM's.
 - _____ Start "Run" clock.
 - _____ Turn on salt pump (C-12) for FOR and heat switch (C-13) to High.
 - _____ When batch (R1) reaches 100° C close both the nitrogen valve (V-7.0) and vent valve (V-1.0), securely!
 - _____ Turn off (D-3), tighten bottom flange, cover, replace TC, turn on (D-3).

4. _____ When PG-1 reaches 50 psig record temperatures and every 50 psig to 400 psig.
 - _____ Turn off (D-1) when pressure reaches 400 psig.
 - _____ Maintain pressure until step 5 with (V-1.1).

NOTE: If vent valve (V-1.1) should become plugged, use auxiliary vent valves in the following order as necessary: (V-1.0, V-1.2, and V-2.0).

III CONTINUED

5. _____ When batch (R1) reaches 325° C, start the depressurization cycle with (V-1.1) while maintaining a low amperage level with the suggested pressure levels with time BUT DO NOT EXCEED 7.0 AMPS.

_____ When pressure reaches 50 psig, open gauge valve (V-5.0) to PG-2.

_____ When 5 psig is reached, open nitrogen valve (V-7.0).

6. _____ When 0 psig is reached, open vent valve (V-1.0) fully.

_____ Set agitator to _____ RPM's.

- a. _____ Record conditions 30 minutes after step 6 and every 30 minutes for a total of _____ hours. Perform operations as indicated on the Run Chart.

- b. _____ Prepare the steam generator system by performing the following:

_____ Open valve (V-11.2) to vent T-4).

_____ Open valves (V-11.9 and -11.3) to fill T-4 with water.

_____ Close valves (V-11.2).

_____ Close valves (V-11.4 and -11.8).

_____ Open valve (V-11.0) and turn power on level controller. With (V-11.3) open, water should feed to T-5 to sight glass and then stop.

_____ Close valve (V-11.3) and open nitrogen valve (V-11.1) to pressure T-4 to 150 psig.

_____ Crack steam valves (V-11.6 and -9.6) and control pressure on PG-4 at or below 100 psig. CHECK this pressure periodically.

7. _____ At the end of the post-heating period, close vent valve (V-1.0) and open nitrogen valve (V-7.1) to pressure reactor. When gauge (PG-2) reaches 5 psig, perform the following:

_____ Turn off (D-1, -2, and -3).

_____ Set (C-4) to 400° F and (C-4A) for 200° C.

III. CONTINUED

- Reverse salt pump (C-12) and turn off.
 - Close steam valves (V-9.6 and -11.6). Open (V-9.4).
 - Open salt valves (V-8.2 and -8.3) fully. At least 9 turns.
 - Close salt valve (V-8.1) fully and then OPEN 4 turns.
 - Turn off (D-8).
 - Turn on salt pump (C-12).
8. When water level in T-4 reaches the bottom of the sight glass perform the following rapidly:
- Close valves (V-11.0 and -11.1).
 - Open valves (V-11.2 and -11.3) and fill T-4 with water.
 - Close valves (V-11.2 and -11.3).
 - Open valves (V-11.1 and -11.0).
9. When water level again reaches the bottom sight glass perform the following:
- Close valves (V-11.0 and -11.1).
 - Open valves (V-11.2 and -11.3) and fill T-4 with water.
 - Close valves (V-11.2 and -11.3).
 - Open valves (V-11.1 and -11.0).
 - Turn on (D-7 and -8).
 - Close salt valve (V-8.1).
10. When RI reaches 250° C perform the following:
- Reverse salt pump (C-12) and hold until bumping in tank.
 - Quickly, open salt valve (V-8.1).
 - Turn off (D-7).
 - Set (C-13) to Low.

- _____ Crack valve (V-11.4) slightly.
- _____ Disconnect the electrical plug to the bottom flange heater.
- _____ Remove double thermocouple in bottom flange.
- _____ Remove insulation cover on bottom flange.
- 11. _____ Pump the phenol/water mixture in T-1 to T-2 as follows:
 - _____ Open valve (V-1.3) at base of T-1.
 - _____ Turn on phenol pump (PS-1) and fill sight glass in T-2 to the _____ lb mark; then turn off (PS-1). Record in step 5, part IV.
 - _____ Open valve (V-2.8) and close valve (V-2.7).
 - _____ Record weight of condensate drum in step 5 of part IV.
 - _____ Turn on (PS-1) and empty T-1 to the drum. Record new drum weight in step 5 of part IV. Turn off (PS-1).
 - _____ Close valves (V-2.8, and -2.5). Open valves (V-1.4, -2.6 and -2.7).
 - _____ Close valve (V-1.3). Turn on (PS-1).
 - _____ Close nitrogen valve (V-11.1). Turn power off level controller to T-5.
 - _____ Open valve (V-1.3). Close valve (V-1.4).
 - _____ When T-1 is empty, turn off (PS-1); open valves (V-2.9 and -2.5); close valve (V-2.6).
- 12. _____ Set multi-point to 1-7/8 speed.
 - _____ Turn off N₂ cylinder.
 - _____ Set (C-9) to 400° F

IV. RUN DISCHARGE PROCEDURES:

1. _____ Close nitrogen valves (V-7.1 and -7.4).
 - _____ Vent reactor by cracking vent valve (V-1.0). Pressure gauge (PG-2) should drop to zero.

- _____ Turn off agitator (AS-1), if it is on.
- _____ Open top port cover; remove sample for I. V. ; screen and submit for I. V.
2. _____ Using the auto-jack, remove the bottom discharge flange bolts.
- _____ Drop the flange sufficiently to insert slide plate.
- _____ Drop flange to floor and remove.
3. _____ Record empty weight of fiber pack below.
- _____ Place fiber pack directly under the slide plate; locate exhaust trunk and remove slide plate dropping batch to pack.
- _____ Turn on agitator switch (AS-1) intermittently.
4. _____ Turn off agitator switch (AS-1) and disconnect (D-5). CHECK TO MAKE SURE !
- _____ Remove balance of polymer by hand.
- _____ Remove fill port cover on reactor head for visual examination.
5. _____ Record the following:

Drum with condensate	lbs
<u>Empty drum</u>	<u>lbs</u>
Condensate	lbs
<u>Condensate pumped to T-2</u>	<u>lbs</u>
Total condensate	lbs
<u>Condensate charged</u>	<u>lbs</u>
Total condensate generated	lbs
Polymer fiber pack	lbs
<u>Empty fiber pack</u>	<u>lbs</u>
Polymer	lbs

Proceed to part II: RUN PREPARATION PROCEDURES

PBI POLYMERIZATION CHARGE LEVELS

<u>Compound</u>	<u>Molecular Weight</u>	<u>Lbs./Lb. PBI</u>
3,3'-diaminobenzidine; DAB	214.25	0.695
diphenylisophthalate; DPIP	318.31	1.032
phenol (2 moles)*	188.22	0.615
water (2 moles)*	36.03	0.117
poly-2,2'-(m-phenylene) -5,5'-bi-benzimidazole; PBI*	308.03	

<u>PBI*</u>	<u>DAB</u>	<u>DPIP</u>	<u>Phenol*</u>	<u>Water*</u>	<u>Total Cond.*</u>
50.00	34.75	51.60	30.75	5.85	36.60
55.00	38.23	56.76	33.83	6.44	40.26
60.00	41.70	61.92	36.90	7.02	43.92
65.00	45.18	67.08	39.98	7.61	47.58
70.00	48.65	72.24	43.05	8.19	51.24
75.00	52.13	77.40	46.13	8.78	54.90
80.00	55.60	82.56	49.20	9.36	58.56
85.00	59.08	87.72	52.28	9.95	62.22
90.00	62.55	92.88	55.35	10.53	65.88
95.00	66.03	98.04	58.43	11.12	69.54
100.00	69.50	103.20	61.50	11.70	73.20
105.00	72.98	108.36	64.58	12.29	76.86
110.00	76.45	113.52	67.65	12.87	80.52
115.00	79.93	118.68	70.73	13.46	84.18
120.00	83.40	123.84	73.80	14.04	87.84
125.00	86.88	129.00	76.88	14.63	91.50

* products of the polymerization reaction of DAB and DPIP

FIGURE 25
PBI SINGLE-STAGE REACTOR

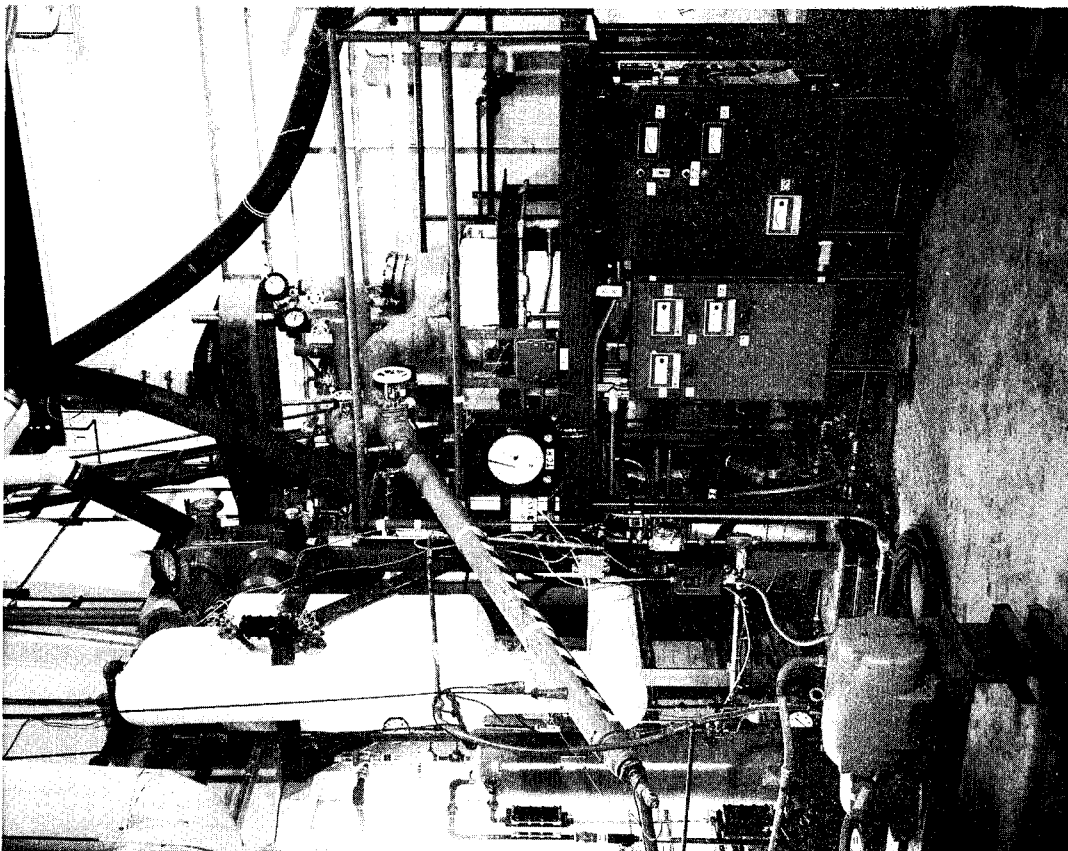
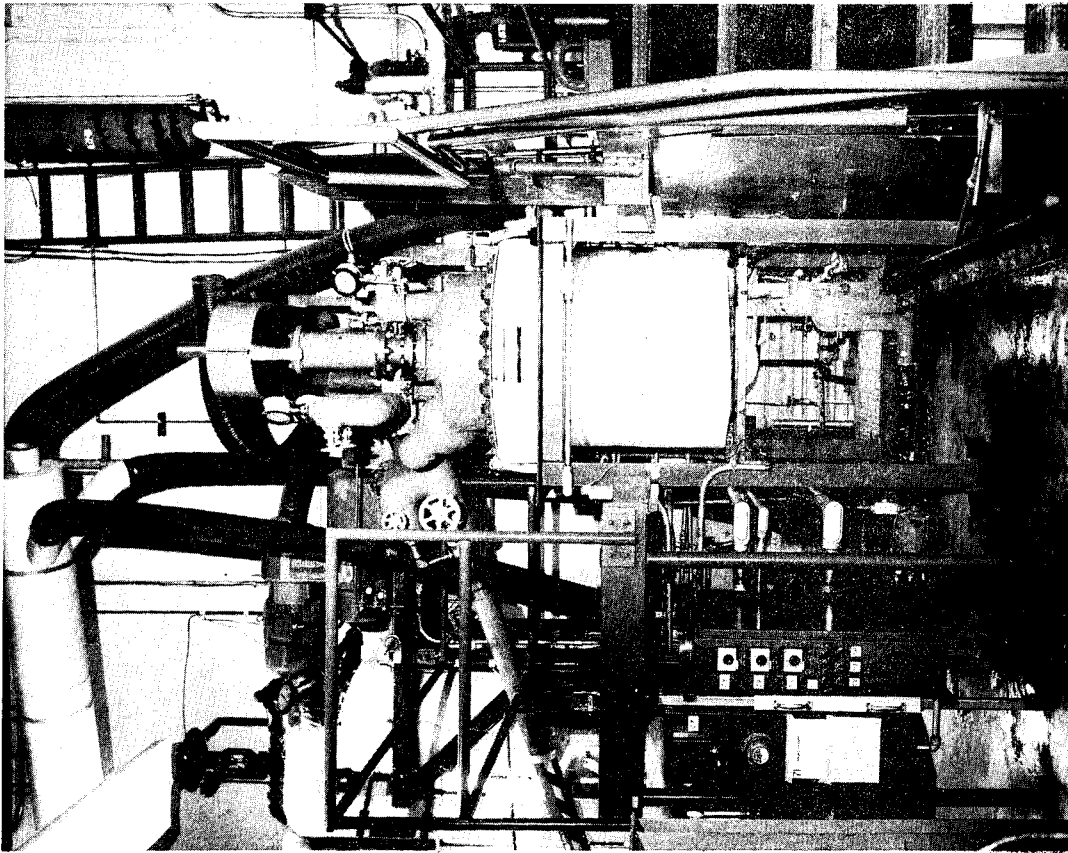
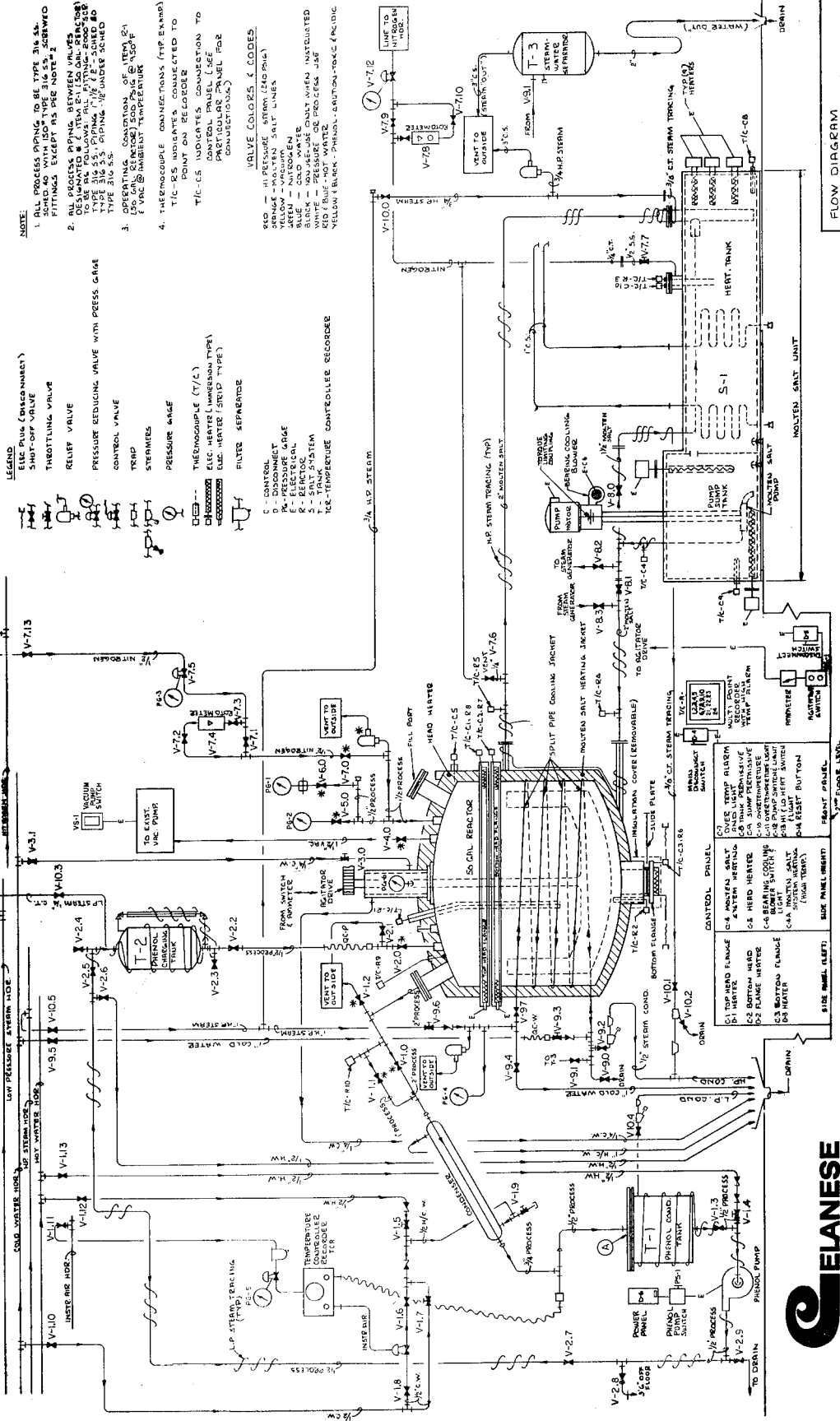

FIGURE 26

SCHEMATIC DIAGRAM OF FIFTY-GALLON REACTOR



LEGEND

ELEC PLUG (DIAGRAMMATIC)
 SHUT-OFF VALVE
 THROTTLING VALVE
 RELIEF VALVE
 PRESSURE REDUCING VALVE WITH PRESS GAUGE
 CONTROL VALVE
 TRIP
 STEAMERS
 PRESSURE GAUGE
 THERMOCOUPLE (T/C)
 ELECTRIC HEATER (UNLESS OTHERWISE NOTED)
 ELECTRIC HEATER (STEADY TYPE)
 FLUXE SEPARATOR

C - CONTROL
 S - SALT
 P - PRESSURE GAUGE
 E - ELECTRICAL
 H - HEAD HEATER
 S - SALT SYSTEM
 T - TANK
 TCR - TEMPERATURE CONTROLLER RECORDER

VALVE COLORS & CODES
 RED - HOT WATER
 BLUE - COLD WATER
 BLACK - INSULATION ONLY WHEN INDICATED
 WHITE - INSULATION PROTECTIVE JAR
 RED (BLACK) - PHENOL - CARBON-DIOXIDE (INDIC)

TIC-85 INDICATES CONNECTED TO POINT ON RECORDER CONNECTION TO PARTICULAR PANEL (SEE CONNECTIONS)

OPERATING CONDITION OF ITEM 2-1
 1 - 100% AMBIENT TEMPERATURE
 2 - 100% AMBIENT TEMPERATURE

THERMOCOUPLE CONNECTIONS (TIP ENDS)
 POINT ON RECORDER CONNECTION TO PARTICULAR PANEL (SEE CONNECTIONS)

VALVE COLORS & CODES
 RED - HOT WATER
 BLUE - COLD WATER
 BLACK - INSULATION ONLY WHEN INDICATED
 WHITE - INSULATION PROTECTIVE JAR
 RED (BLACK) - PHENOL - CARBON-DIOXIDE (INDIC)

NOTE:

1. ALL PROCESS PIPING TO BE TYPE 316 SS. SCHEDULE 40 WITH ISO-TYPE 316 SS. SCREWED FITTINGS EXCEPT AS PER NOTE 2.
2. ALL PROCESS PIPING BETWEEN VALVES SHOULD BE FOLLOWED BY ALL FITTINGS - ISO-TYPE 316 SS. PIPING. 1/2" UNLESS NOTED TYPE 316 SS.
3. OPERATING CONDITION OF ITEM 2-1 IS 100% AMBIENT TEMPERATURE.
4. THERMOCOUPLE CONNECTIONS (TIP ENDS) POINT ON RECORDER CONNECTION TO PARTICULAR PANEL (SEE CONNECTIONS).

FLOW DIAGRAM
 PSI PROCESS - 50 GAL REACTOR
 SCALE: SCHEMATIC
 DRAWN BY PARTY MANAGER
 APPROVED BY DWG. NO. 1923-193

REVISED 7-8-71



GLOSSARY

<u>ITEM</u>	<u>FUNCTION</u>	<u>LOCATION</u>
CONDENSING SYSTEM		
V-1.0	Main venting valve (2")	Between reactor and condenser
V-1.1	Auxilliary vent valve	Between reactor and condenser
V-1.2	Emergency vent valve	To the right of V-1.1
V-1.3	Discharge of T-1	Between T-1 and phenol pump
V-1.4	Hot water to phenol line	At phenol pump
V-1.5	Hot water to condenser	Behind frame
V-1.6	Cold water to condenser	Behind frame
V-1.7	Cold water by-pass	Behind frame
V-1.8	Cold water to condenser	Behind frame
V-1.9	Drain on condenser jacket	Base of condenser
V-1.10	Main cold water to condenser	Pipe on wall
V-1.11	Instrument air	Pipe on wall
V-1.12	Main hot water to condenser	Pipe on wall
V-1.13	Main hot water to T-1	Pipe on wall
PHENOL SYSTEM		
V-2.0	Emergency vent valve & Phenol charge to reactor	Reactor head-right side
V-2.1	Emergency vent valve & Breather and drainage valve	Between reactor head and T-2
V-2.2	Discharge of T-2	Base of T-2
V-2.3	Drain of T-2	Base of T-2
V-2.4	Breather on T-2	Top of T-2
V-2.5	Charge valve to T-2	Top of T-2
V-2.6	Flushing valve on phenol line	Top of T-2
V-2.7	Flow valve from T-1 to T-2	Behind frame
V-2.8	Flow valve from T-1 to drum	Edge of frame
V-2.9	Drain of T-1	At phenol pump

<u>ITEM</u>	<u>FUNCTION</u>	<u>LOCATION</u>
AGITATOR PACKING GLAND		
V-3.0	Cold water to packing gland	Top of frame-right side
V-3.1	Main cold water to gland	Pipe on wall
VACUUM SYSTEM		
V-4.0	Main vacuum valve for purging	Reactor head-right side
PRESSURE GAGES		
V-5.0	Close off vacuum-pressure gage	Reactor head-left side
V-6.0	Close off pressure gage	Reactor head-left side
NITROGEN SYSTEM		
V-7.0	Main nitrogen to reactor	Reactor head-far left side
V-7.1	By-pass for rotometer	Base of agitator drive
V-7.2	Rotometer cutoff	Base of agitator drive
V-7.3	Rotometer cutoff	Base of agitator drive
V-7.4	Nitrogen rotometer for reactor	Base of agitator drive
V-7.5	Nitrogen regulator for reactor	Base of agitator drive
V-7.6	Valve to reactor jacket and line	Exit salt line on reactor
V-7.7	Purge for salt system	Behind shields to S-1
V-7.8	Nitrogen rotometer for salt system	Near double doorway
V-7.9	Rotometer cutoff	Near double doorway
V-7.10	Rotometer cutoff	Near double doorway
V-7.11	By-pass for rotometer	Near double doorway
V-7.12	Nitrogen regulator for salt system	Near double doorway
V-7.13	Main valve to reactor regulator	On wall behind drive
SALT SYSTEM		
V-8.0	By-pass for sump to tank	Extension handle under T-2
V-8.1	Sump to reactor jacket	Extension handle left of V-8.0
V-8.2	Sump to steam generator	Extension handle rear of V-8.0
V-8.3	Steam generator to reactor jacket	Extension handle next to V-8.2

<u>ITEM</u>	<u>FUNCTION</u>	<u>LOCATION</u>
REACTOR COIL SYSTEM		
V-9.0	Bottom vent line to drain	Under reactor
V-9.1	Vent valve to T-3	Under reactor
V-9.2	Steam condensate to drain	Under reactor
V-9.3	Cold water to coil	Extension handle, base of steps
V-9.4	Top vent line to drain	Extension handle, back of reactor
V-9.5	Main cold water to QC-W	Pipe on wall
V-9.6	High pressure steam to the reactor coil and steam generator	Under T-2 at PG-4
V-9.7	Top valve to coil	Extension handle, back of reactor
STEAM SYSTEM		
V-10.0	High pressure steam to salt trace	Behind rail above S-1
V-10.1	Steam condensate to drain	Under reactor
V-10.2	Vent valve for trace	Under reactor
V-10.3	Low pressure steam to phenol trace	Above T-2
V-10.4	Steam condensate to drain	Wall at T-1
STEAM GENERATOR SYSTEM		
V-11.0	Water valve from T-4 to T-5	Between T-4 and T-5
V-11.1	Nitrogen to T-4	Right side of T-4
V-11.2	Vent on T-4	Top of T-4
V-11.3	Cold water to T-4	Left side of T-4
V-11.4	Emergency Vent & breather valve	Above T-5
V-11.5	Pressure venting control valve	Above T-5
V-11.6	Water solenoid valve	Below V-11.0
V-11.7	High pressure steam to T-5	Base of T-5
V-11.8	Drain on T-5	Base of T-5
V-11.9	Main cold water to T-4	Wall at T-4
SWITCHES & DISCONNECTS		
AS-1	Agitator start and stop buttons	Right side of temperature recorder
PS-1	Phenol pump switch	Above phenol pump at T-1
VS-1	Vacuum pump start and stop buttons	Right of double doorway

<u>ITEM</u>	<u>FUNCTION</u>	<u>LOCATION</u>
SWITCHES & DISCONNECT CONT'D.		
D-1	Top head flange heater	Left control panel
D-2	Bottom head flange heater	Left control panel
D-3	Bottom discharge flange heater	Left control panel
D-4	Main for salt system	Right of double doorway
D-5	Main for agitator drive	Right of double doorway
D-6	Main for phenol pump	In back of 150 gal. reactor
D-7	Salt pipe and valve heaters	Left control panel
D-8	Salt pipe and valve heaters	Left control panel

CONTROLS

C-1	Top head flange heater	Left control panel
C-2	Bottom head flange heater	Left control panel
C-3	Bottom discharge flange heater	Left control panel
C-4	Salt circulating heating - Low	Right control panel
C-4A	Salt circulating heating - High	Right control panel
C-5	Head heater	Right control panel
C-6	Bearing blower switch and light	Right control panel
C-7	Over-temp. alarm, light, button	Edge of right control panel
C-8	Tank permissive set for pump	Front control panel
C-9	Sump permissive set for pump	Front control panel
C-10	Over-temp. set point	Front control panel
C-11	Over-temp. light	Front control panel
C-12	Pump permissive switch and light	Front control panel
C-13	Tank heaters, HI, OFF, LO	Front control panel
C-14	Reset button	Front control panel

GAGES

PG-1	High pressure for reactor	Reactor head-left side
PG-2	Vacuum-pressure for reactor	Reactor head-left side
PG-3	Nitrogen regulator for reactor	Base of agitator drive
PG-4	High pressure steam	Under T-2
PG-5	Instrument air	Behind frame
PG-6	Pressure on packing gland	On agitator gland
PG-7	Nitrogen regulator for S-1	Right of double doorway
PG-8	Nitrogen regulator for T-4	At nitrogen cylinder
PG-9	Pressure in T-4	Top of T-4
PG-10	Pressure in T-5	Top of T-5

APPENDIX II

DETERMINATION OF RESIDUAL DIMETHYLACETAMIDE IN PBI YARN

SCOPE

1. This method was developed for the determination of residual N, N-dimethylacetamide (DMAc) in PBI yarns and is particularly suited to the quantitative analysis in the low (<1%) concentration range. The method is superior to and replaces CRC Method and Procedure MP-21-S.

PRINCIPLE OF METHOD

2. A sample of PBI yarn is extracted with distilled water in a micro Soxhlet extractor for five hours. The extract is quantitatively diluted to volume in a volumetric flask and an aliquot is injected into a gas chromatograph. The column used for the chromatographic determination of DMAc is a three feet by 1/4", o. d., 10% DEGS coated on Chromosorb W and the detector is flame ionization. The temperature is set at 125°C. Duplicate extractions should be performed on each sample.

REAGENTS

3. (a) N, N-dimethylacetamide, best grade available.

APPARATUS

4. (a) Micro extraction apparatus, Soxhlet, available from Fisher Scientific Co., Cat. No. 20-650.
(b) Heating mantle to fit micro flask of Soxhlet.
(c) Gas chromatograph with flame ionization detector and 3' x 1/4", o. d., stainless steel column packed with 10% DEGS on Chromosorb W.
(d) Syringe, 10 microliter
(e) Volumetric flasks, 25 ml

PROCEDURE

5. (a) Preparation of Sample

Accurately weigh a 1.5 - 2.0g sample of PBI yarn on an analytical balance pan. Carefully transfer the yarn to the top half of the micro Soxhlet extractor and press the bulky yarn into the extractor interior below the level of its siphon arm. Add approximately twenty milliliters of distilled water to the flask and a boiling chip or two and place the flask in the heating mantle.

The extractor and flask should be wrapped with glass wool. Adjust the temperature of the heating mantle so there is a vigorous reflux. Allow the water to percolate through the fiber for five hours. Quantitatively transfer the contents of the Soxhlet flask to a 25 ml volumetric flask. Dilute to volume with distilled water.

(b) Preparation of Standards

Quantitatively weigh separate portions of approximately 10 mg, 20 mg, 30 mg, and 40 mg of DMAc into each of four 25 ml volumetric flasks and dilute to volume with distilled water.

(c) Gas Chromatography

Employ the chromatographic conditions listed below:

Instrument: Gas chromatographic equipped with flame ionization detector.

Column: 3' x 1/4", O. D., 10% DEGS on Chromosorb W

Column Temperature: 125°C

Injection Port Temperature: 225°C

Detector Temperature: 250°C

Flow Rate: 25-35 ml/min

Carrier gas: Nitrogen

Sample Size: Three microliter injection for both standards and samples
(see Note 1)

Note 1:

The syringe should be rinsed about five times with distilled water between injections. It appears that there is a slight adsorption of DMAc on the interior glass walls of the syringe and the desorption of DMAc in subsequent samples can lead to erroneous results especially if a dilute sample follows a more concentrated one. Before injection of a new sample the syringe should be rinsed at least three times with that sample.

Integrate the areas under the chromatographic peak for both standards and samples using a planimeter (or other manual method) or automatically using a digital integrator or computer system.

Construct a calibration curve for the four standards by plotting the integrated area of the peaks versus the weight of DMAc in the standard solution to verify the linearity of the detector and system. Once it is established that the

calibration plot is linear only a single standard needs to be run each day of analysis.

CALCULATION

6. The weight percent of DMAc in the PBI yarn is calculated using equation (1).

$$\text{Wt. \% DMAc} = \frac{A_s \cdot W_{\text{std}} \cdot 100}{A_{\text{std}} \cdot W_s} \quad \text{Eqn. 1}$$

A_s = integrated area for sample

A_{std} = integrated area for one standard containing W_{std} of DMAc

W_{std} = weight of DMAc in standard solution, g

W_s = weight of sample, g

STUDY OF EXTRACTION VERSUS EXTRACTABILITY

7. A study was initiated to determine the time needed to completely extract the DMAc from the PBI yarn under vigorous reflux conditions. Five separate one gram samples from a single bobbin of PBI yarn were carried through the extraction procedure but the reflux was stopped at four different times. The solutions were diluted to volume and chromatographed. Figure 27 shows the percent of DMAc extracted versus the time of extraction. The absence of DMAc in the completely extracted PBI was verified by mass spectrometry. Figure 27 shows that 98% of the DMAc is extracted in about four hours, but to be sure of complete extraction of all samples, five hours is the recommended extraction time.

REPRODUCIBILITY

8. At the 0.2% by weight level, the average deviation for duplicate analyses on eight different samples was $\pm 7\%$ relative. At the level of 4% the average deviation was 2% relative.

INTERFERENCES

9. There are no interferences in this method.

FIGURE 27

AMOUNT OF DMAc EXTRACTED FROM PBI AS A FUNCTION OF TIME

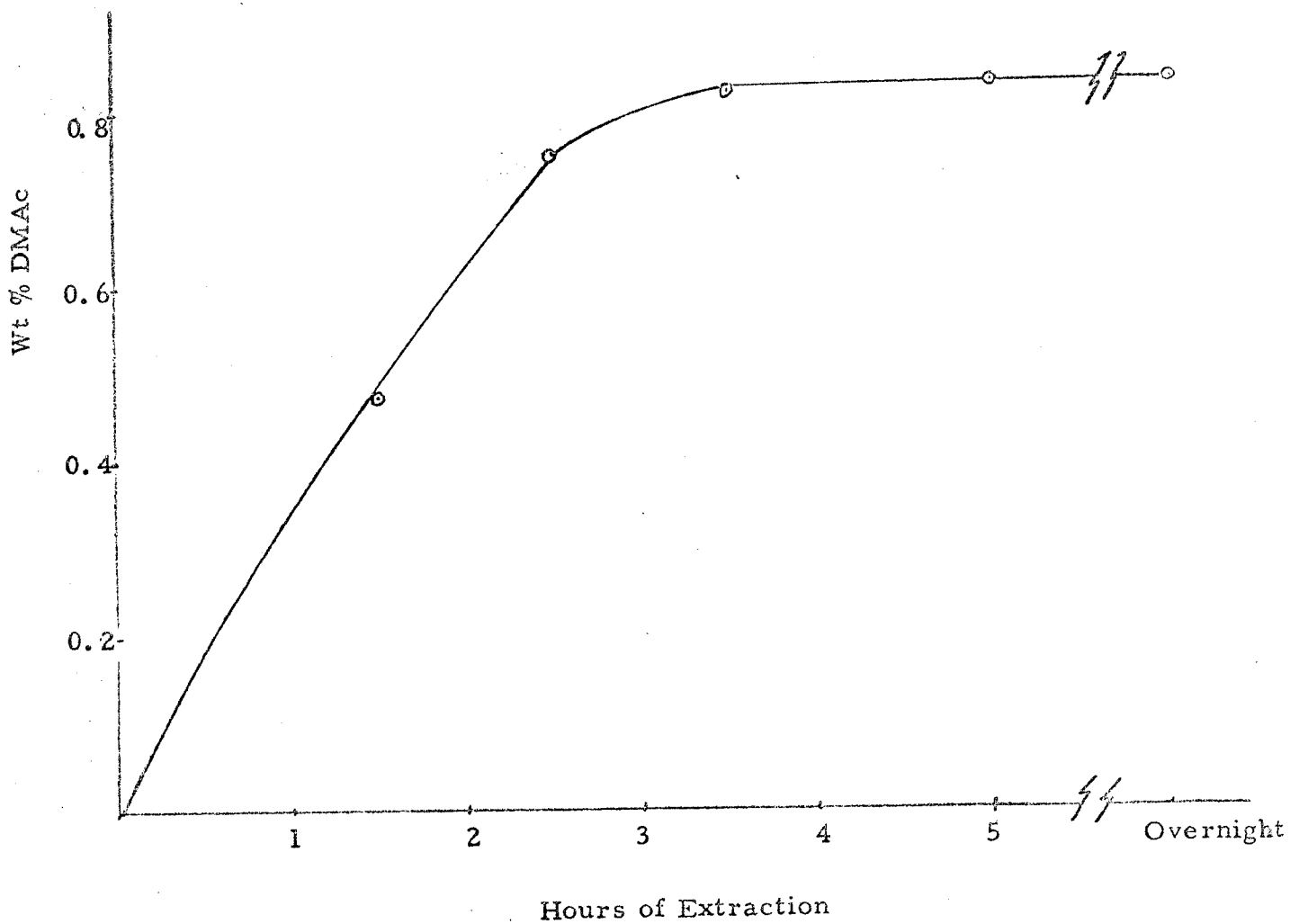

APPENDIX III

ACCEPTANCE TEST PROCEDURES

The following physical testing procedures for fiber properties represent the Acceptance Test Procedures employed in the performance of this contract.

-116-
SUMMIT PHYSICAL TESTING PROCEDURE
STANDARD METHOD
FOR
YARN DENIER, REEL METHOD

Scope:

This method is intended for determining the denier of yarn by means of a denier reel and a balance.

Apparatus:

1. Hand operated denier reel of 1.125 meter perimeter with traversing mechanism.
2. Balance having sensitivity of 0.25% of skein weight.

Specimen:

1. A package (bobbin, cone, etc.) with sufficient yarn for a 90 meter skein.
2. Condition sample for 24 hours at 65% R.H. \pm 2% and 70^oF \pm 2^oF prior to testing.

Procedure:

1. Place package on floor in upright position under the denier reel.
2. Attach end of specimen to middle rod of the reel making sure that it is passed through the loop guards.
3. Reel off a 90 meter skein as indicated on dial.

Note: The tension of the yarn shall not be heavier than is necessary to lay the yarn smoothly on the reel at a speed not to exceed 300 rpm. This can be accomplished by turning the hand crank of the reel at a speed of one revolution per second.

4. Cut the yarn at both ends and tie them together at the middle rod making sure any excess is cut off.
5. Remove the skein from the reel carefully, coil it loosely and weigh on the balance.
6. Calculate the denier of the yarn as follows:

$$\text{Denier} = \frac{W \times 9000}{L}$$

where W = weight of skein (gms)

L = Length of skein (meters)

Report:

1. Denier of yarn.

Reference:

1. ASTM-D-1380-62T
2. ASTM-D-1907-61T

-117-
SUMMIT PHYSICAL TESTING PROCEDURE
STANDARD METHOD
FOR
FIBER DENIER - VIBROSCOPE METHOD

Scope:

This method is intended for determining the denier (linear density) of single fibers by using the vibroscope.

Apparatus:

1. Direct View (Ocular) or projection type vibroscope. (See SUM-S-5005-Calibration of Vibroscope).
2. Hewlett Packard Audio Oscillator, model 201-B.
3. Beryllium bronze coiled spring wire for tension weights.

Specimen:

1. Fibers of sufficient length so that they may be tested with instron tensile tester in gage length specified by investigator. Number of fibers also are specified by investigator.
2. Condition samples for 24 hours at 65% RH \pm 2% and 70°F \pm 2° prior to testing.

Procedure A - Uncrimped Fibers:

1. Set the oscillator amplitude control at about 50 and the attenuator at zero. The amplitude control may have to be set higher to obtain a more visible resonant frequency. Most routine work can be done with the multiplier set at 10X.
2. Fasten the proper tensioning weight to one end of the fiber using the following table:

<u>Fiber Denier</u>	<u>Tensioning Weight - Grams</u>
0.40 - 1.00	0.020
1.00 - 2.00	0.040
2.00 - 5.00	0.080
5.00 - 12.00	0.160
12.00 - 24.00	0.320

3. Clamp the fiber in the vibroscope in such a manner that the filament is in contact with both knife edges and that the tension weight hangs freely.

Note:

Short filaments or staple cannot be clamped conventionally, therefore a small "Bulldog" clip, with masking tape lining the jaw faces is used to hold the specimen, and one of the clip's lever arms is clamped to the vibroscope.

4. Increase the oscillator frequency gradually, starting from a point considerably lower than the expected fundamental resonant frequency, while observing the amplitude of vibration. When maximum amplitude is reached (the widest band produced by the vibrating fiber) decrease the oscillator frequency and readjust the frequency to the point of maximum amplitude of vibration.
5. Read the frequency of the oscillator and record the denier of the fiber by using the conversion tables, which are labeled according to the tensioning weight used and are based on the following formula: (1)

$$\text{Denier (grams/9000m)} = K \times \frac{W \times 980 \times 900,000}{4L^2 F^2} = 5.51 \times 10^7 K \frac{W}{F^2}$$

where K = correction factor (1.00 in most cases)
W = pretension weight in grams
L = effective fiber length (2.00 cm.)
F = fundamental resonant frequency in cycles per second

6. Repeat steps 3 through 5 for the remaining fibers in the sample.

Procedure B - Crimped Fibers:

1. This procedure is the same as Procedure A - uncrimped fibers except for the tensioning weights used. For most commercial fibers, crimp can be removed sufficiently for vibroscoping using a tensioning weight of 0.060 grams/denier.
2. Determine the tensioning weight required for crimp removal on fibers of unknown crimp characteristics by the following procedure:

- a) Extend the fiber 0.5 percent and calculate the tensioning load from the following formula:

$$T = 0.005 \times \text{denier} \times \text{I.M.}$$

Where T = tensioning load in grams

Denier = the nominal denier of the fiber

I.M. = the approximate initial modulus of the fiber in grams/denier

3. Determine denier using formula (1) above.

Report:

1. Denier, individual and average values.

Reference:

1. ASTM-D-1577-62T

SUMMIT PHYSICAL TESTING PROCEDURE
STANDARD METHOD
FOR
OPERATION OF INSTRON TENSILE TESTER

Scope:

This method is intended to be used as a guide for the set-up and operation of the Instron testing machine for general tensile testing.

Procedure:

1. Installation of Load Cell and Jaws:

- a) Select a load cell with a load range corresponding to the tensile strength of the material being tested as follows:

<u>Load Cell</u>	<u>Color</u>	<u>Normal Range</u>	<u>High Range</u>
A	Blue	10 - 50 grams	2 - 40 grams
B	Red	100-2000 grams	20 - 400 grams
C	Green	1 - 50 lbs	0.2 - 10 lbs
CT	Gold	5 - 200 lbs	1 - 40 lbs
D	Grey	20 - 1000 lbs	4 - 200 lbs

- b) Install the desired load cell through the hole in the center of the upper crosshead making sure that it fits over the dowels in the crosshead.
- c) Install the jaws corresponding to the load cell used. The top jaw is coupled to the load cell with a flexible bayonet coupling except on the A load cell where an extension wire is used. The lower jaw is held in place in the large mount located in the center of the moving crosshead by a connector pin.

2. Load Cell Balancing and Recorder Zeroing:

- a) Place range switch in the position corresponding to the load cell used. This two position switch sets the proper circuit into use depending upon the load cell used. On the floor model instron, the switch is marked ABC in the left position and D in the right position. On the table model instron the switch is marked ABC in the left position and CT in the right position.
- b) Place range sensitivity switch in either high or normal position whichever is desired. High sensitivity is used only when operating in the lowest load range of the load cell in use.
- c) Place pen switch on.
- d) Depress the zero button and turn the adjusting zero knob until the pen is on the zero line of the chart thus zeroing the recorder. Release the zero button. Pen may now drift off zero line.

- e). Balance the load cell by turning the fine balance knob until the pen is on the zero line of the chart. If it is not possible to position the pen on the zero line then turn the coarse balance knob until the pen can be adjusted with the fine balance control.
- f) Turn pen switch off.

3. Calibration of Load Cell:

a) Straight Load Method:

- 1) Add the proper calibrating weight to the upper jaw using the chart below as a guide.

<u>Load Cell</u>	<u>Range</u>	<u>Selector</u>	<u>Cal Wgt.</u>	<u>Pen Deflection</u>	<u>Load Full Scale</u>
A	ABC	1	10 gms.	full scale	10 grams
B	ABC	1	100 gms	" "	100 grams
C	ABC	1	1 lb	" "	1 lb
CT	ABC	1	5 lb	" "	5 lb
CT (table)	CT	5 (red)	5 lb	" "	5 lb
D	D	2	10 lb	half scale	20 lb

Note:

The above table is for normal sensitivity. If the high sensitivity is used then all the above values would be decreased 80%.

- 2) Turn pen switch on, (The pen will deflect across the chart), making sure that the dial-in-denier switch is in the off position.
- 3) Turn the calibration adjustment at the center of the recorder panel until the pen is deflected to the proper line on the chart. (Full scale for cells A, B, C, and CT and half scale for cell D).
- 4) Depress the zero button and allow pen to return to the zero line of the chart. Turn pen switch off. If the pen does not return to the zero line then the zero adjustment and calibration adjustment must be repeated.
- 5) Turn the full scale load selector to the full scale load desired. The numbers on the dial selector are designated as 1, 2, 5, 10, and 20. Whatever weight is used on selector 1, the rest of the numbers represent a multiple of this weight according to their respective number. e.g. Full scale load at selector 1 = 10 grams, therefore full scale load at selector 5 = 50 grams.

b) Dial - in - Denier Method:

- 1) Place dial-in-denier switch to the in position.
- 2) Turn dial-in-denier dial to 100.
- 3) Add the proper calibrating weight to the upper jaw using the examples below as a guide.

<u>Cal. Wgt.</u>	<u>Load Cell</u>	<u>Selector</u>	<u>Range Denier</u>	<u>F. S. L.</u>	<u>Range Sensitivity Switch</u>
5 grams	A	2	1-9.99	5 g/d	High
10 grams	A	1	1-9.99	10 g/d	Normal
50 grams	B	2	10-99.9	5 g/d	High
100 grams	B	1	10-99.9	10 g/d	Normal

Note:

The calibrating weight is determined by multiplying the full scale stress desired by 1, 10, 100 or 1000. These numbers are for designating reference decimal location for the deniers of the fibers being tested. e.g. 10 represents denier range of 10.0 to 99.9. Therefore if a full scale stress of 20 grams per denier is desired, a calibrating weight of 200 grams would be used.

The high sensitivity range should be used only when necessary. If there is a choice between the two the normal range should be used.

- 4) Place pen switch on. (The pen will deflect across the chart).
- 5) Turn the calibration adjustment at the center of the recorder panel until the pen is deflected to the full scale line on the chart.
- 6) Turn dial-in-denier dial to 200. The pen should deflect to the half-scale line of the chart. If it doesn't go exactly on half-scale, the dial-in-denier area compensator must be adjusted. (See Sum-S-5004).
- 7) Turn dial to 400. The pen deflection should be exactly at quarter scale.
- 8) Depress the zero button and allow pen to return to the zero line of the chart. Turn pen switch off. If the pen does not return to the zero line then the zero adjustment and calibration must be repeated.
- 9) Turn the selector if necessary to the full scale stress desired. The numbers on the dial selector are multiples of the full scale stress (grams/denier) initially calibrated for.

4. Selection of Gage Length:

- a) Determine the gage length to be used. This is usually specified by the investigator, in writing on the work request.
- b) Shut crosshead motor off.
- c) Hold a ruler or gage marker against the upper and lower jaws and move the crosshead until the gage length desired is obtained. The crosshead is moved by turning the manual positioning knob in the crosshead section.
- d) Set gage length dial to zero.

- 3) Set return dial to a position so that the crosshead will have sufficient amount to travel without automatically stopping or returning before the specimen being tested is broken.

5. Selection of Chart and Crosshead Speeds:

- a) Insert the gears that drive the chart. The gear pins for the chart are located behind the chart recorder. The combination of chart change gears to give the desired speeds are listed by each gear box.
- b) Insert the gears that drive the crosshead. These gears pins are located in the crosshead section of the instron. For normal tensile testing, the crosshead speed is 60% of the gage length. e.g. Gage Length = 10", therefore crosshead speed = 6"/min. The combination of crosshead change gears to give the desired speeds are listed by each gear box.

Reference:

1. Instron Manual, 10-13-1-(1)
2. Instron Manual, 10-29-1

SUMMIT PHYSICAL TESTING PROCEDURE
STANDARD METHOD
FOR
TENSILE CHART CALCULATIONS OF SINGLE FIBERS

Scope:

This method is intended for determining the tenacity (grams/denier), elongation (percentage of initial gage length), modulus of elasticity (grams/denier,) and offset yield strength (grams/denier) of a single fiber tensile specimen, through the analysis of a tensile stress-strain curve as recorded on an Instron tensile testing chart.

Data Recorded on Chart:

1. Tensile specimen stress-strain curves.
2. Stress corresponding to full width of chart (grams/denier).
3. Chart speed (inches/min).
4. Crosshead speed (inches/min).
5. Gage length (inches - initial jaw separation).

Evaluation:

1. Calculate the tenacity in grams/denier as follows:
 - a) Determine the stress at rupture on the tensile curve.
(See Figure 1, Point C.)
2. Calculate the elongation (percentage of initial gage length) as follows:
 - a) Measure the distance E in inches. (See Figure 1)
 - b) Determine the elongation factor as follows:
 - 1)
$$\text{Elongation Factor} = \frac{\text{Chart speed}}{\text{Crosshead speed}} \times \text{gage length.}$$
 - c) Determine the elongation, % as follows:
 - 1)
$$\text{Elongation, \%} = \frac{\text{Distance E}}{\text{Elongation Factor}} \times 100$$

Note:

In the event of a crimped fiber, or if slack is present in the fiber mounting, the amount of crimp or slack must be recorded on the chart. This amount is then used to obtain the corrected elongation factor due to the change in gage length as follows: (See Figure 2).

- a) Draw the line M tangent to the initial straight line portion of the curve.
- b) Measure the distance C in inches from the pip mark P to where the line M intersects the zero stress line at point A.
- c) Add the distance C to the elongation factor.

- d) Measure the distance E of the curve in inches.
- e) Therefore - Elongation, % = $\frac{\text{Distance E}}{\text{Elongation Factor} + \text{Distance C}} \times 100$

3. Calculate the modulus of elasticity as follows: (See Figure 1).

- a) Draw the line M tangent to the initial straight line portion of the curve.
- b) Lay off distance D so that D is a whole number of inches, e.g., 3 inches.
- c) Draw line P through point A parallel to the stress axis so that it intersects line M at point B.
- d) Determine stress corresponding to point B.
- e) Calculate the modulus of elasticity by applying the following formula:

1) Modulus of Elasticity = $\frac{\text{stress}}{\text{strain}}$

2) Example 1:

- a) Instron Conditions: Gage length = 3.33"
Chart speed = 10"/min.
Crosshead speed = 2"/min.
Full Scale Stress = 10 grams/denier.
- b) Chart Conditions: Point "B" = 5 grams/denier. (See Figure 1)
Distance "D" = 3.00".
- c) Stress = Point "B" - 5 grams/denier.
- d) Strain = $\frac{\text{Distance "D"}}{\text{Elongation Factor}}$
 - 1) Elongation Factor = $\frac{10"/\text{min}}{2"/\text{min}} \times 3.33" = \underline{16.7"}$.
 - 2) Distance "D" = 3.00".
 - 3) Therefore - Strain = $\frac{3.00"}{16.7"} = \underline{.18}$
- e) Modulus of elasticity = $\frac{5.00 \text{ grams/denier}}{.18} = \underline{\underline{27.8 \text{ grams/denier}}}$

Note:

In the event of a crimped fiber, or if slack is present in the fiber mounting, the amount of crimp or slack must be recorded on the chart. This amount is then used to obtain the corrected strain value for the distance "D" as follows: (See Figure 2).

- 1) Strain =
$$\frac{\text{Distance "D"}}{\text{Elongation Factor} + (\text{distance "C"})}$$
4. Calculate the offset yield strength as follows: (see figure 3)
- Lay off the distance OM on the strain axis corresponding to 1% elongation.
 - Draw OA tangent to the initial straight line portion of the curve.
 - Draw a line MN through M parallel to OA and locate the intersection (R) of MN with the curve.
 - Determine offset yield strength in grams/denier at point R.

Report:

- Tenacity (grams/denier), individual and average values.
- Elongation % (of initial gage length), individual and average values.
- Modulus of elasticity, (grams/denier), individual and average values.
- Offset yield strength (grams/denier) at 1%, individual and average values.

Reference:

- ASTM-D-213-60, 1961
- ASTM-D-638-60T, 1961

Attach:

- Appendix of Definitions
- Figure 1, Tensile Curve - Uncrimped Fiber
- Figure 2, Tensile Curve - Crimped Fiber
- Figure 3, offset - yield strength

APPENDIX
DEFINITIONS

1. Breaking Load:

For a specimen of any material, the maximum load in a tensile test carried to rupture.

2. Elongation Factor:

A constant, used to facilitate the calculation of elongation, % when testing a series of specimens under the same Instron conditions.

Elongation Factor = $\frac{\text{chart speed}}{\text{crosshead speed}}$ x gage length

3. Elongation, %:

The percent elongation is calculated by dividing the extension of a tensile curve from the zero stress level to the breaking stress level along the zero stress line by the elongation factor.

4. Modulus of Elasticity :

The ratio of change in stress to change in strain in the initial straight line portion of a stress-strain curve following the removal of any crimp. The ratio is calculated from the stress expressed in force per unit linear density and the strain expressed as a fraction of the original length.

5. Tensile Stress:

The resultant internal resistance to deformation developed within a specimen subjected to tension by an external load. The tensile stress is expressed as force per unit linear density, (grams /denier).

6. Tenacity:

Tensile stress at rupture, expressed in terms of force per unit linear density as grams/denier.

Figure 1

Tensile Curve - Uncrimped Fiber

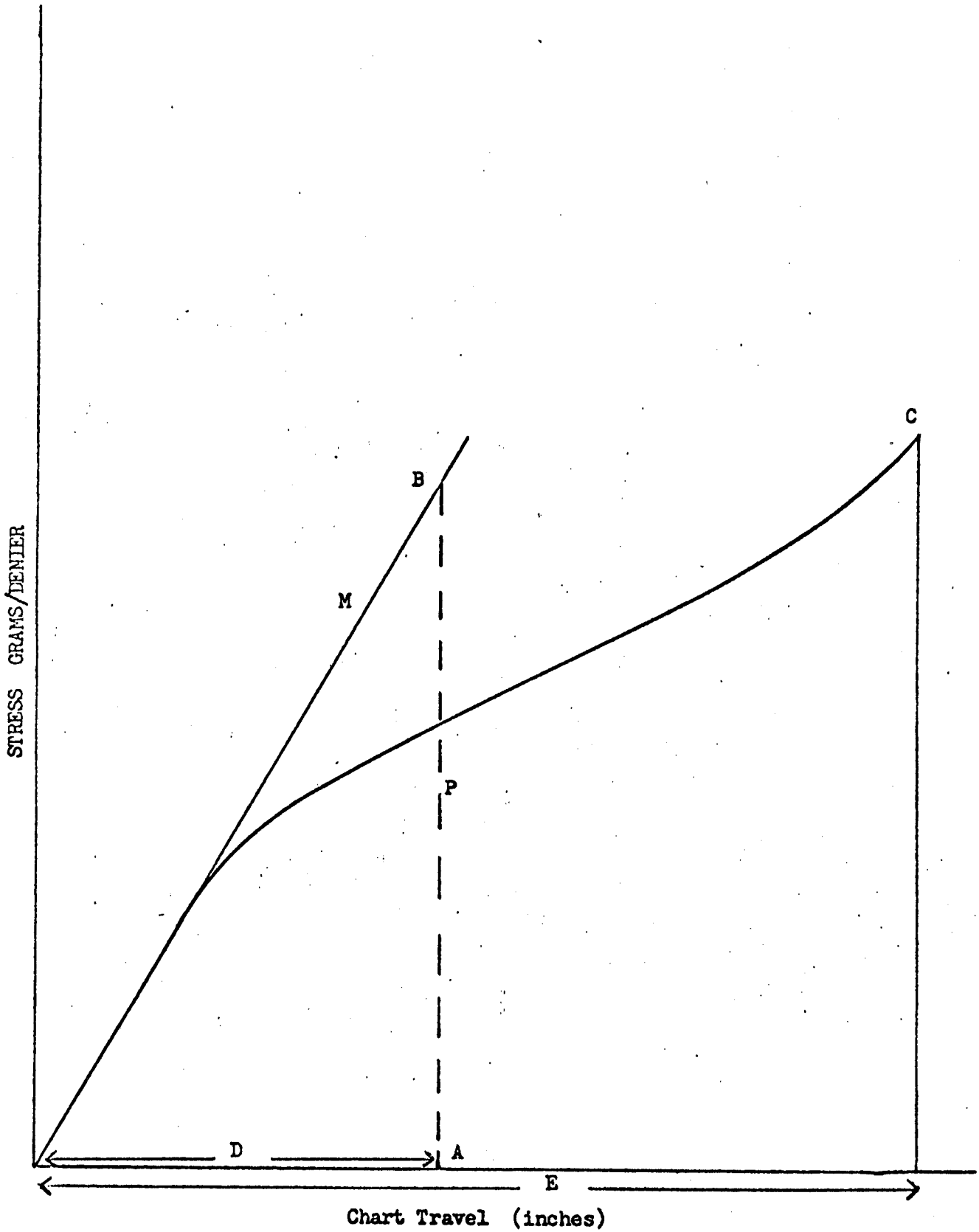
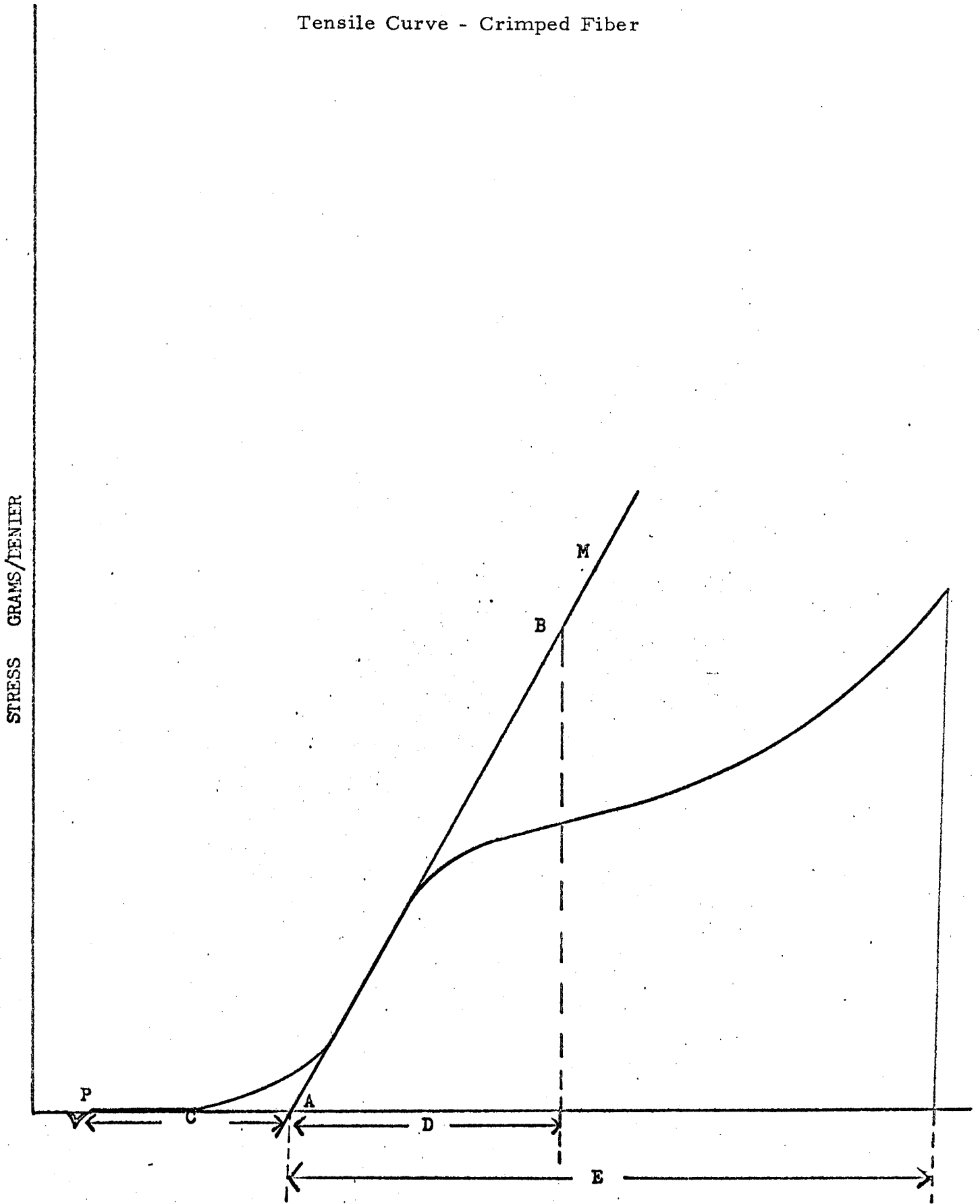

Figure 1

Tensile Curve - Crimped Fiber



Figure

Figure 3

Offset Yield Strength

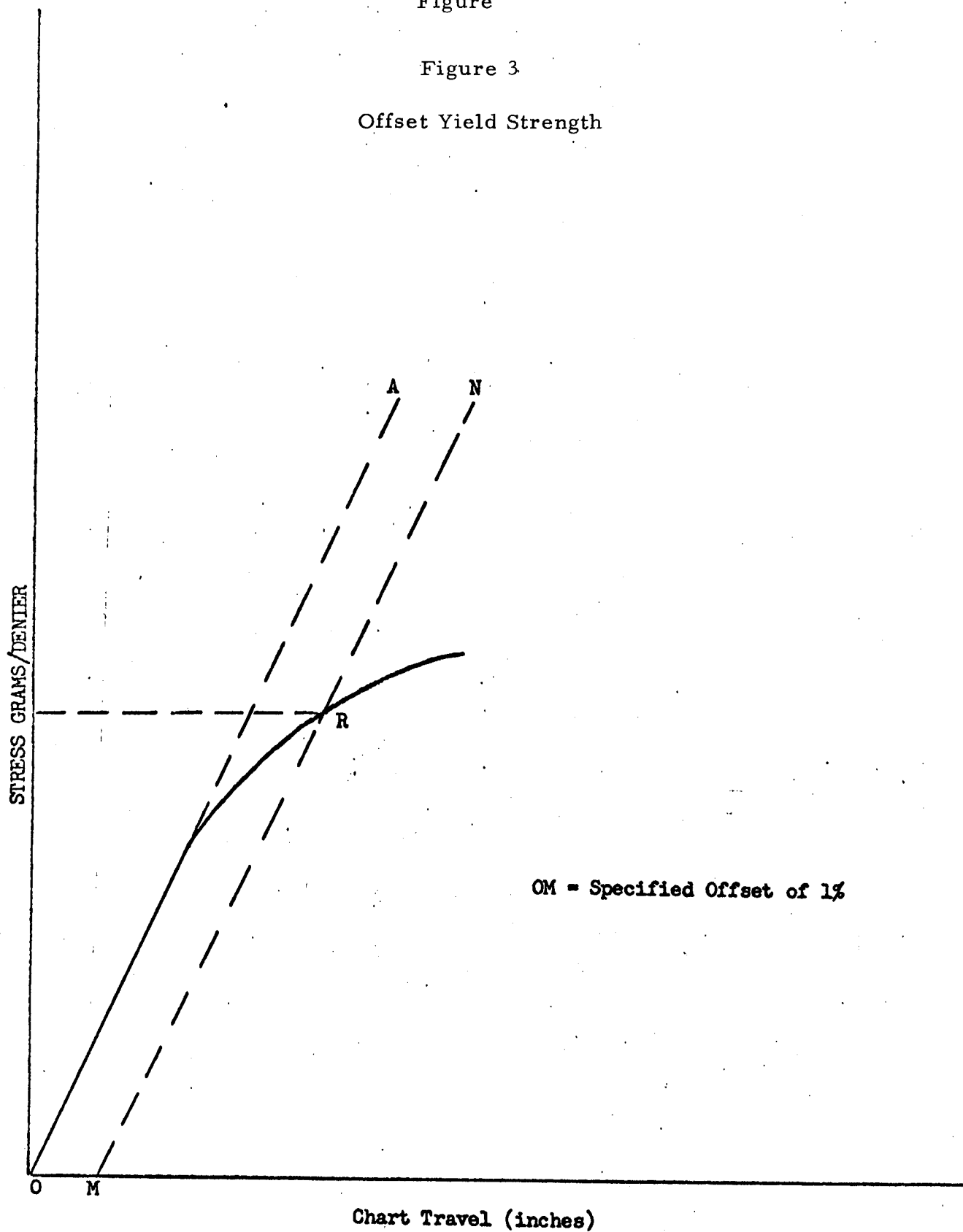

SUMMIT PHYSICAL TESTING PROCEDURE
STANDARD METHOD
FOR
MOISTURE REGAIN OF FIBERS

Scope:

This method is intended to determine the moisture regain of fibers at the conditions of 65% RH and 70°F after being conditioned at 20% RH and 50°C.

Apparatus:

1. Weighing bottle, glass, approximately 100- ml capacity, fitted with a ground-glass cover.
2. Dessicator, containing anhydrous calcium chloride.
3. Analytical Balance.
4. Vacuum oven
5. Convection oven

Specimen:

1. Two specimens weighing approximately 1 gram each.

Procedure:

1. Place samples in convection oven and condition them for 12 hours at 20% RH and 50°C.
2. Condition samples for 24 hours at 65% RH and 70°F.
3. Place the weighing bottles and covers separately in the vacuum oven at a temperature of 105°C to 110°C and dry for 1 hour.
4. Replace the cover, transfer the weighing bottle to the dessicator and allow it to cool to room temperature.
5. Remove the cover momentarily to equalize the pressure, and with the cover in place, weigh the container.
6. Place the specimen to be tested in the container, cover, and weigh.
7. Subtract the weight of the empty container from the weight (item 6) to obtain the air-dry weight of the specimen, weight A.
8. Place the uncovered weighing bottle and specimen into the vacuum oven for 1½ hours at a temperature of 105°C to 110°C.
9. Cover and transfer the container to a dessicator, allowing it to cool to room temperature.

10. Remove the cover momentarily to adjust the pressure, replace the cover and weigh.
11. Subtract the weight of the empty container from the weight (item 10) to obtain the oven-dry weight of the specimen, weight B.
12. Calculate the moisture regain % of the specimen as follows:

$$\text{Moisture Regain, percent} = \frac{A-B}{B} \times 100$$

where A = air-dry weight of specimen
 B = oven-dry weight of specimen

Report:

1. Moisture regain, percent, individual and average values.

Reference:

1. ASTM-D-629-59T

Distribution List

AFML (LTP, Mr. C. S. Anderson) (10 cys) Wright-Patterson AFB, Ohio 45433	Department of Navy Special Projects Office Washington, D. C. 20360
AFML (MAAM, Library) Wright Patterson AFB, Ohio 45433	Director, Army Technical Information U. S. Army Research Office OCRD Room 209 A Arlington, Va. 22204
AFML (LNF, J. Ross) (6 cys) Wright-Patterson AFB, Ohio 45433	
AFML (LNP) (2 cys) Wright-Patterson AFB, Ohio 45433	HQ USAF (AFCSAI) Study Information Group Asst. Chief of Staff for Study and Analysis Washington, D. C. 20330
AFML (DOY) Wright-Patterson AFB, Ohio 45433	
ASNPD-30 Wright-Patterson AFB, Ohio 45433	HQ USAF (AFRDPI/Mr. A. W. Luther) Commonwealth Bldg. Room 1137 1320 Wilson Boulevard Arlington, Va. 22209
FTD (PDBP) Wright-Patterson AFB, Ohio 45433	
4950/PMRB (N. Averill) Wright-Patterson AFB, Ohio 45433	HQ USAF/SAMID Washington, D. C. 20330 (1 cy)
4950/TZDE (1 cy) Wright-Patterson AFB, Ohio 45433	NASA Lewis Research Center (Library) 21000 Brookpark Road Cleveland, Ohio 44135
2750th ABW/SSL (1 cy) Wright-Patterson AFB, Ohio 45433	NASA George C. Marshall Space Flight Center Attn: J. Curry Huntsville, Ala. 35812
AF Cambridge Research Lab. Bedford, Mass. 01731	
Air University Attn: Library Maxwell AFB, Alabama 36112	NASA MSC EC4 Attn: F. Dawn Houston, Texas 75202
DCASD 240 Route 22 Springfield, N. J. 07081	NASA (OARP) Washington, D. C. 20546
Defense Documentation Center (2 cys) Cameron Station Alexandria, Va. 22314	NASA (Langley) Attn: G. Pezdirtz Stop 407 Hampton, Va. 23361

OSD (DDRE)
Materials Division
Office Asst. Dir. Chemical Tech.
Washington, D. C. 20301

Plastics Technical Center
SMUPA-VP-3
Picatinny Arsenal
Dover, N. J. 07801

Scientific & Tech. Info. Facility
P. O. Box 5700
Bethesda, Md. 20014

U. S. Army Natick Lab.
Clothing & Organic Material
Natick, Mass. 01760

Aerospace Corporation
Tech. Reports
2400 El Segundo Blvd.
El Segundo, California

Allied Chemical Corporation
Attn: Dr. H. R. Naumark
P. O. Box 405
Morristown, N. J.

American Mfg. Co., Inc.
Attn: Mr. R. L. Stanton
Noble & West St.
Brooklyn, N. Y. 11222

The American Thread Company
Attn: Mr. D. H. Fields
Willimantic, Conn. 06226

AVCO R&D Corporation
Materials Department
201 Lowell Street
Wilmington, Massachusetts 01887

B. F. Goodrich Co.
Research Center (Aerospace)
Brecksville, Ohio 44141

The Boeing Company
Aerospace Division
P. O. Box 3707
Seattle, Wash. 98124

The Budd Co. (Polychem)
Attn: E. O. Hausmann
70 Chapel Street
Newark, N. J. 07105

Beaunit Fibers
Division of Beaunit Corp.
P. O. Box 12234
Triangle Park, N. C.

Celanese Fiber Co.
522 Fifth Avenue
New York, N. Y. 10036

Celanese Fiber Co.
Attn: Dr. Paul H. Cannon
Charlotte, N. C. 28201

Chemstrand Corporation
Attn: J. C. Stehman
P. O. Box 731
Durham, N. C. 27702

Convair General Dynamics
Attn: H. D. Neubert
Dept. 512-2
San Diego, California 92101

Douglas Aircraft
Missile & Space System
Dept. A-250
Santa Monica, California 90406

Dow-Corning
Attn: Mr. C. Doremire
Midland, Mich. 48641

E. I. DuPont de Nemour Co.
Attn: Dr. A. H. Frazer
Wilmington, Del. 19898

Fabric Research Lab.
1000 Providence Highway
Dedham, Mass. 02026

Fireston Tire Rubber Co.
Chemical Phy. Research Lab.
Akron, Ohio 44317

Flexible Tubing Corp.
Automation Industries, Inc.
R&E Department
Attn: G. R. Richitelli
Abbeville, S. C. 29620

General Electric Company
Attn: E. L. Bartelo
P. O. Box 2143
Kettering Branch
Dayton, Ohio 45429 (1 cy)

Georgia Inst. Technology
A. French Textile School
Atlanta, Ga. 30304

Goodyear Aerospace Corporation
Attn: Library
Akron, Ohio 44309

Hexcel Co.
E. C. Vicars R.D.
1711 Dublin Blvd.
Dublin, Calif. 94566

HITCO
Attn: Mr. R. S. Moore
1600 W. 135th St.
Gardena, California

Hughes Aircraft Co.
Attn: R. W. Jones
R. D. Division
Culver City, Calif. 90232

Huyck Felt Co.
J. D. Chesney
Rensselaer, N. Y. 12144

J. P. Stevens and Co., Inc.
Synthetic Fabrics
1460 Broadway
New York, New York 10012

Lowell Tech. Institute R.D.
1 Textile Ave.
Box 709
Lowell, Mass. 01107

Massachusetts Institute Tech.
Textile Division
Cambridge, Mass. 01109

3M Company
Fiber Department
444 McKnight Rd.
St. Paul, Minn.

3 M Company
Attn: Robert H. Lamb
333 West First St.
Suit 612
Dayton, Ohio 45402

Monsanto Research Corp.
Attn: Library
1515 Nicholas Rd.
Dayton, Ohio 45407

North American Aviation, Inc.
Paraglide Matl. Group
12214 Lakewood Blvd.
Downey, California

North Carolina Sci. & Tech. Res. Center
Attn: Mrs. S. G. Johnson
P. O. Box 8857
Durham, N. C. 27707

North Carolina State College
School of Textiles
Attn: Dr. R. W. Work
Raleigh, N. C. 27601

Northrup Ventura
1515 Rancho Conejo, Blvd.
Newberry Park, Calif. 91320

Owens Illinois
Attn: D. N. Gray
Red Cedar Research Park
Okemos, Mich. 48864

Owens Illinois
Technical Prod. Division
711 Southwood Ave.
Columbus, Ohio 43207

Philco Ford Corporation
Attn: Mr. B. Bandaruk
Ford Road
Newport Beach, Calif. 92663

Sandia Corporation
Attn: C. F. Bild (Mat'l Br)
Sandia Base Box 5800
Albuquerque, N. Mexico 87115

Sandia Corporation
Box 969 (Library)
Livermore, Calif. 94551

Space General Corporation
Attn: Mr. J. F. Heville
El Monte, Calif.

Tennessee Eastman Co.
Textile Engineer
Bldg. 162A
Kingsport, Tenn. 37660

TRW, Inc.
Equipment Lab.
23555 Euclid Ave.
Cleveland, Ohio 44117

Union Carbide Co.
Textile Fibers
270 Park Avenue
New York, N. Y. 10010

Uniroyal
Attn: Dr. G. R. Cuthbertson
Textile Research
Waynesboro, Ga. 30830

United Aircraft Corporation
Materials Section (Research Lab)
400 Main Street
E. Hartford, Conn. 06101

U. S. Rubber Co.
Research Center
Attn: Dr. J. S. Laskey
Wayne, N. J. 07470

U. S. Testing Co.
Textile Sales
1415 Park Avenue
Hoboken, N. J. 07030

University of Arizona
Department of Chemistry
Attn: Dr. C. S. Marvel
Tucson, Arizona 85252

University of Minnesota
Dept. of Aeronautical Engr.
Minneapolis, Minn. 55401

The Upjohn Company (1 cy)
Attn: C. W. Stewart
Commercial Development
Kalamazoo, Michigan 49001

DOCUMENT CONTROL DATA - R & D

(Security classification of title, body of abstract and indexing annotation must be entered when the overall report is classified)

1. ORIGINATING ACTIVITY (Corporate author) Celanese Corporation Celanese Research Company Summit, New Jersey		2a. REPORT SECURITY CLASSIFICATION Unclassified	
3. REPORT TITLE PBI Tow Manufacturing Methods		2b. GROUP	
4. DESCRIPTIVE NOTES (Type of report and inclusive dates) Final Technical Report			
5. AUTHOR(S) (First name, middle initial, last name) Prince, Arthur E Arthur E. Prince			
6. REPORT DATE August 1971		7a. TOTAL NO. OF PAGES 132	7b. NO. OF REFS 0
8a. CONTRACT OR GRANT NO. F 33615-70-C-1266		9a. ORIGINATOR'S REPORT NUMBER(S)	
b. PROJECT NO. 389-9		9b. OTHER REPORT NO(S) (Any other numbers that may be assigned this report) AFML-TR-71-154	
c.			
d.			
10. DISTRIBUTION STATEMENT This document has been approved for public release and sale; its distribution is unlimited.			
11. SUPPLEMENTARY NOTES		12. SPONSORING MILITARY ACTIVITY Air Force Materials Laboratory AFSC Wright-Patterson AFB, Ohio	
13. ABSTRACT The purpose of this project was to (a) scale-up the single stage polymerization process (b) increase spinning productivity (c) establish a tow process for processing large bundles of yarn in a continuous manner (d) produce 500 lbs of quality product, and (e) revise the projected economics of a 1 MM lb/yr production plant. The scale-up of the single-stage PBI polymerization process in a specially designed 50-gallon reactor was successful with the attainment of polymer I. V. 's in the 0.7 to 0.9 range at the target capacity level. Insufficient time was available, however, to fully optimize the process conditions. Spinning productivity was nearly doubled by establishing the ability to spin 200-hole jets. This was the maximum number of holes attainable in a single ring with the available pilot equipment; however, 300 or more holes could be employed in a commercial application. The potential for additional spinning productivity was demonstrated by spinning and drawing higher filament deniers to give target properties. New jet starting techniques were demonstrated. Large 5.5 lb packages were produced with both columns being run simultaneously. Continuous washing, drying, and drawing in tandem was demonstrated with PBI tows of 1000 to 5000 filaments. Target properties were achieved and a total of 500 lbs of tow was produced. A revised preliminary plant design was prepared for a 1MM lb/yr PBI plant producing 0.8 MM lb/yr of staple and 0.2 MM lb/yr of filament yarn. The production cost, assuming \$5.00/lb for DAB and \$1.00/lb for DPIIP, was \$7.56/lb overall. The biggest factor is obviously the purchase price of DAB which accounts at this price level for two-thirds of the production cost.			

14. KEY WORDS	LINK A		LINK B		LINK C	
	ROLE	WT	ROLE	WT	ROLE	WT
PBI (Polybenzimidazole) Fiber Processes						
PBI Staple						
PBI Tow						